

## Smart High-Side Power Switch for Industrial Applications

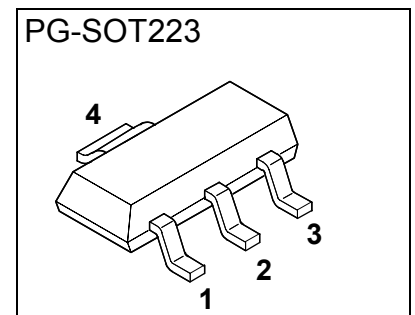
### One channel: 1 x 1 $\Omega$

#### Features

- Current controlled input
- Short circuit protection
- Current limitation
- Overload protection
- Overvoltage protection (including load dump)
- Switching inductive loads
- Clamp of negative voltage at output with inductive loads
- Thermal shutdown with restart
- ESD – Protection
- Loss of GND and loss of  $V_{bb}$  protection
- Very low standby current
- Reverse battery protection
- Improved electromagnetic compatibility (EMC)

#### Product Summary

Overvoltage protection	$V_{bbin(AZ)}$	62	V
Operating voltage	$V_{bb(on)}$	4,9...60	V
On-state resistance	$R_{ON}$	1	$\Omega$
Operating Temperature	$T_a$	-30 ... +85	$^{\circ}\text{C}$



#### Application

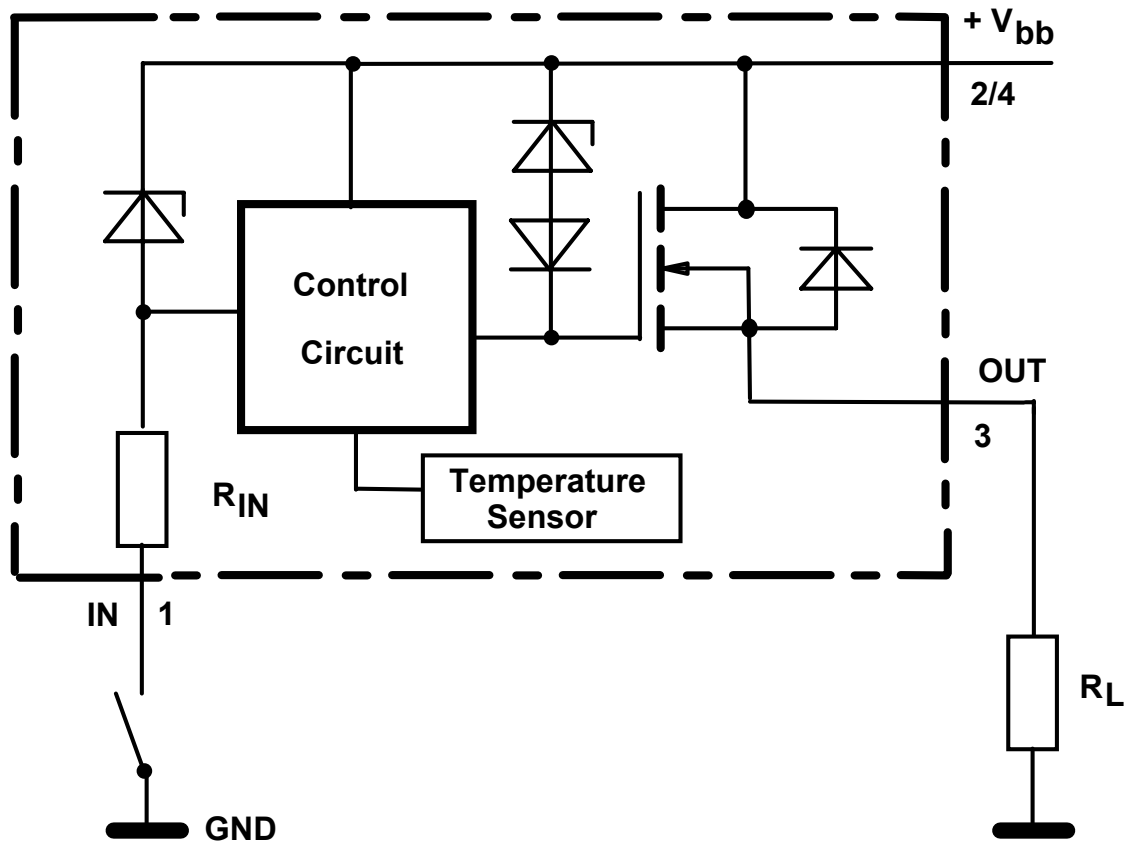
- All types of resistive, inductive and capacitive loads in industrial applications
- Current controlled power switch for 12V, 24V and 42V DC industrial applications
- Driver for electromagnetic relays
- Signal amplifier

#### General Description

- N channel vertical power MOSFET with charge pump and current controlled input, monolithically integrated in Smart SIPMOS<sup>®</sup> technology.
- Providing embedded protection functions.

Type	Ordering code	Package
ITS 4140N	SP000240073	PG-SOT223

Block Diagram



Pin	Symbol	Function
1	IN	Input, activates the power switch in case of connection to GND
2	Vbb	Positive power supply voltage
3	OUT	Output to the load
4	Vbb	Positive power supply voltage

**Maximum Ratings**

Parameter at $T_j = 25^\circ\text{C}$ unless otherwise specified	Symbol	Values	Unit
Supply voltage	$V_{bb}$	60	V
Load current (Short – circuit current, see page 5)	$I_L$	self limited	A
Maximum current through the input pin (DC)	$I_{IN}$	$\pm 15$	mA
Junction temperature	$T_j$	+150	$^\circ\text{C}$
Operating temperature range	$T_a$	-30 ... +85	
Storage temperature range	$T_{stg}$	-40 ... +105	
Power dissipation <sup>1)</sup> $T_a = 25^\circ\text{C}$	$P_{tot}$	1.7	W
Inductive load switch-off energy dissipation <sup>2)</sup> Single pulse $T_j = 150^\circ\text{C}$ , $I_L = 0.15\text{A}$	$E_{AS}$	1	J
Load dump protection <sup>3)</sup> $V_{LoadDump}^{4)} = V_A + V_S$ $R_L = 2\Omega$ , $t_d = 400\text{ms}$ , $V_{IN} = \text{low or high}$ $I_L = 150\text{mA}$ , $V_{bb} = 13.5\text{V}$ $V_{bb} = 27\text{V}$	$V_{LoadDump}$	93.5 127	V
<b>Electrostatic discharge voltage</b> (Human Body Model) According to ANSI EOS/ESD – S5.1 – 1993 ESD STM5.1 – 1998 Input pin all other pins	$V_{ESD}$	$\pm 1$ $\pm 5$	kV

<sup>1)</sup> Device on 50mm\*50mm\*1.5mm epoxy PCB FR4 with 6 cm<sup>2</sup> (one layer, 70 $\mu\text{m}$  thick) copper area for  $V_{bb}$  connection. PCB is vertical without blown air.

<sup>2)</sup> Not subject to production test, specified by design

<sup>3)</sup> More details see EMC-Characteristics on page 7

<sup>4)</sup>  $V_{LoadDump}$  is setup without the DUT connected to the generator per ISO 7637-1 and DIN 40839.

**Electrical Characteristics**

Parameter	Symbol	Values			Unit
		min.	typ.	max.	
at $T_j = -40 \dots 150 \text{ }^\circ\text{C}$ , $V_{bb} = 9 \dots 42 \text{ V}$ unless otherwise specified					

**Thermal Characteristics**

Thermal resistance @ min. footprint	$R_{th(JA)}$	-	86	125	K/W
Thermal resistance @ 6 cm <sup>2</sup> cooling area <sup>1)</sup>	$R_{th(JA)}$	-	60	72	
Thermal resistance, junction - soldering point	$R_{th(JS)}$	-	-	17	K/W

**Load Switching Capabilities and Characteristics**

On-state resistance	$R_{ON}$				$\Omega$
Pin1 connected to GND					
$T_j = 25 \text{ }^\circ\text{C}$ , $I_L = 150 \text{ mA}$ , $V_{bb} = 9 \dots 52 \text{ V}$		-	1	1.5	
$T_j = 150 \text{ }^\circ\text{C}$		-	1.5	3	
$T_j = 25 \text{ }^\circ\text{C}$ , $I_L = 50 \text{ mA}$ , $V_{bb} = 6 \text{ V}$		-	2	5	
Nominal load current <sup>2)</sup>	$I_{L(nom)}$	0.2	-	-	A
Device on PCB <sup>1)</sup>					
$T_a = 85 \text{ }^\circ\text{C}$ , $T_j \leq 150 \text{ }^\circ\text{C}$					
Turn-on time <sup>3)</sup> $V_{IN} = V_{bb}$ to 0V to 90% $V_{OUT}$	$t_{on}$				$\mu\text{s}$
$R_L = 270 \text{ }\Omega$		-	-	125 <sup>4)</sup>	
$R_L = 270 \text{ }\Omega$ , $V_{bb} = 13.5 \text{ V}$ , $T_j = 25 \text{ }^\circ\text{C}$		-	45	100	
Turn-off time <sup>3)</sup> $V_{IN} = 0\text{V}$ to $V_{bb}$ to 10% $V_{OUT}$	$t_{off}$				$\mu\text{s}$
$R_L = 270 \text{ }\Omega$		-	-	175 <sup>4)</sup>	
$R_L = 270 \text{ }\Omega$ , $V_{bb} = 13.5 \text{ V}$ , $T_j = 25 \text{ }^\circ\text{C}$		-	40	140	
Slew rate on <sup>3)</sup> $V_{IN} = V_{bb}$ to 0V 10 to 30% $V_{OUT}$	$dV/dt_{on}$				V/ $\mu\text{s}$
$R_L = 270 \text{ }\Omega$		-	-	6 <sup>4)</sup>	
$R_L = 270 \text{ }\Omega$ , $T_j = 25 \text{ }^\circ\text{C}$ , $V_{bb} = 13.5 \text{ V}$		-	1.3	4	
Slew rate off <sup>3)</sup> $V_{IN} = 0\text{V}$ to $V_{bb}$ 70 to 40% $V_{OUT}$	$-dV/dt_{off}$				V/ $\mu\text{s}$
$R_L = 270 \text{ }\Omega$		-	-	8 <sup>4)</sup>	
$R_L = 270 \text{ }\Omega$ , $T_j = 25 \text{ }^\circ\text{C}$ , $V_{bb} = 13.5 \text{ V}$		-	1.7	4	

<sup>1)</sup> Device on 50mm\*50mm\*1.5mm epoxy PCB FR4 with 6 cm<sup>2</sup> (one layer, 70 $\mu\text{m}$  thick) copper area for  $V_{bb}$  connection. PCB is vertical without blown air.

<sup>2)</sup> Nominal load current is limited by the current limitation ( see page 5 )

<sup>3)</sup> Timing values only with high input slewrates, otherwise slower.

<sup>4)</sup> not subject to production test, specified by design

**Electrical Characteristics**

Parameter at $T_j = -40 \dots 150 \text{ }^\circ\text{C}$ , $V_{bb} = 9 \dots 42 \text{ V}$ unless otherwise specified	Symbol	Values			Unit
		min.	typ.	max.	

**Operating Parameters**

Operating voltage	$V_{bb(\text{on})}$	4.9	-	60	V
Standby current Pin1 = open	$I_{bb(\text{off})}$	-	2	10	$\mu\text{A}$

**Protection Functions<sup>1)</sup>**

Initial peak short circuit current limit (see page 14) $T_j = -40 \text{ }^\circ\text{C}$ , $V_{bb} = 13.5 \text{ V}$ , $t_m = 100 \text{ } \mu\text{s}$ $T_j = 25 \text{ }^\circ\text{C}$ $T_j = 150 \text{ }^\circ\text{C}$	$I_{L(\text{SCp})}$	-	-	1.2	A
		-	0.9	-	
		0.2	-	-	
Repetitive short circuit current limit $T_j = T_{jt}$	$I_{L(\text{SCR})}$	-	0.7	-	
Output clamp (inductive load switch off) at $V_{\text{OUT}} = V_{bb} - V_{\text{ON(CL)}}$ , $I_{bb} = 4 \text{ mA}$	$V_{\text{ON(CL)}}$	60	-	-	V
Overvoltage protection $I_{bb} = 1 \text{ mA}$	$V_{bb(\text{in(AZ)})}$	62	68	-	
Thermal overload trip temperature	$T_{jt}$	150	-	-	$^\circ\text{C}$
Thermal hysteresis	$\Delta T_{jt}$	-	10	-	K

<sup>1)</sup> Integrated protection functions are designed to prevent IC destruction under fault conditions described in the data sheet. Fault conditions are considered as "outside" normal operating range. Protection functions are not designed for continuous repetitive operation.

**Electrical Characteristics**

Parameter at $T_j = -40...150\text{ °C}$ , $V_{bb} = 9...42\text{ V}$ unless otherwise specified	Symbol	Values			Unit
		min.	typ.	max.	
<b>Input</b>					
Off state input current $V_{OUT} \leq 0.1\text{ V}$ $T_j = 25\text{ °C}$ , $R_L = 270\ \Omega$ $T_j = 150\text{ °C}$	$I_{IN(off)}$	-	-	0.05	mA
		-	-	0.04	
On state input current ( Pin1 grounded ) <sup>1)</sup>	$I_{IN(on)}$	-	0.3	1	
Input resistance	$R_I$	0.5	1	2.5	k $\Omega$

**Reverse Battery**

Continuous reverse drain current $T_C = 25\text{ °C}$	$I_S$	-	-	0.2	A
Drain-source diode voltage ( $V_{OUT} > V_{bb}$ ) $I_F = 0.2\text{ A}$ , $I_{IN} \leq 0,05\text{ mA}$	$-V_{ON}$	-	600	-	mV

<sup>1)</sup>Driver circuit must be able to drive currents > 1mA.

### EMC-Characteristics

All EMC-Characteristics are based on limited number of samples and no part of production test.

#### Test Conditions:

If not other specified the test circuitry is the minimal functional configuration without any external components for protection or filtering.

Supply voltage:	$V_{bb} = 13.5V$	Temperature:	$T_a = 23 \pm 5^\circ C$ ;
Load:	$R_L = 220\Omega$		
Operation mode:	PWM DC On/Off	Frequency:	100Hz / Duty Cycle: 50%
DUT-Specific.:	-		

### Fast electrical transients

Acc. ISO 7637

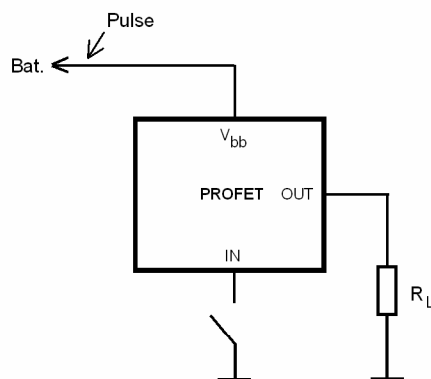
Test Pulse	Test Level	Test Results		Pulse Cycle Time and Generator Impedance
		On	Off	
1	-200 V	C	C	500ms ; 10 $\Omega$
2	+200 V	C	C	500ms ; 10 $\Omega$
3a	-200 V	C	C	100ms ; 50 $\Omega$
3b	+ 200 V	C	C	100ms ; 50 $\Omega$
4 <sup>1)</sup>	-7 V	C	C	0,01 $\Omega$
5	175 V	E (150V)	E (150V)	400ms ; 2 $\Omega$

The test pulses are applied at  $V_{bb}$

### Definition of functional status

Class	Content
C	All functions of the device are performed as designed after exposure to disturbance.
E	One or more function of a device does not perform as designed after exposure and can not be returned to proper operation without repairing or replacing the device. The value after the character shows the limit.

### Test circuit:

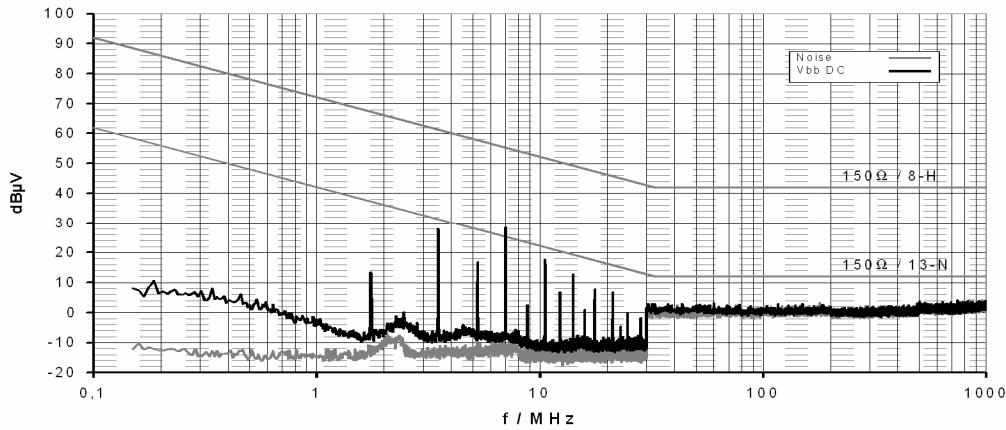


<sup>1</sup>Supply voltage  $V_{bb} = 12 V$  instead of 13.5 V.

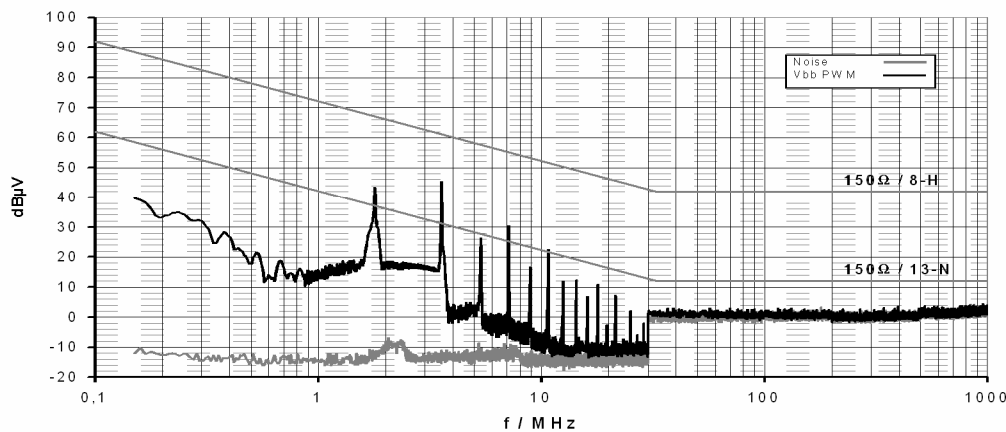
### Conducted Emission

Acc. IEC 61967-4 (1Ω / 150Ω method)

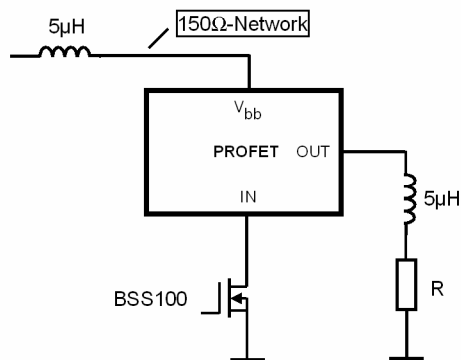
#### Typ. $V_{bb}$ -Pin Emission at DC-On with 150Ω-matching network



#### Typ. $V_{bb}$ -Pin Emission at PWM-Mode with 150Ω-matching network



#### Test circuit:



For defined decoupling and high reproducibility a defined choke (5μH at 1 MHz) is inserted between supply and  $V_{bb}$ -pin.

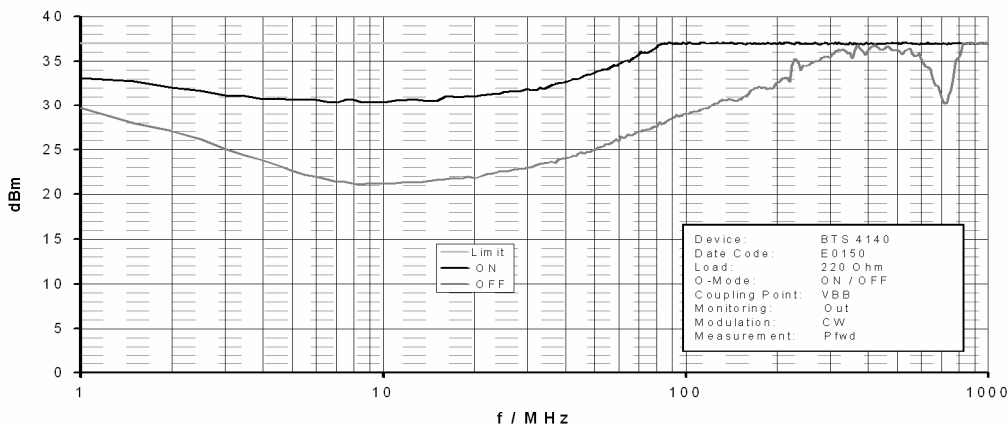


### Conducted Susceptibility

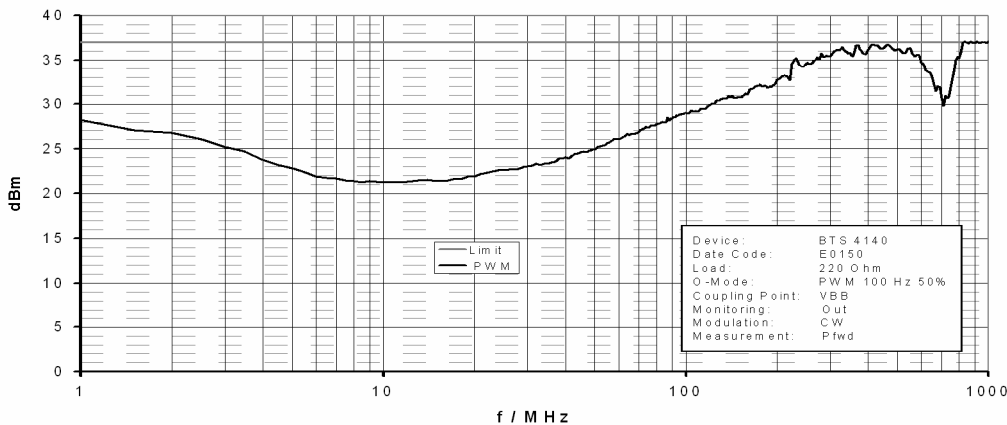
Acc. 47A/658/CD IEC 62132-4 (Direct Power Injection)

**Direct Power Injection:** Forward Power CW  
**Failure criteria:** Amplitude and frequency deviation max. 10% at Out

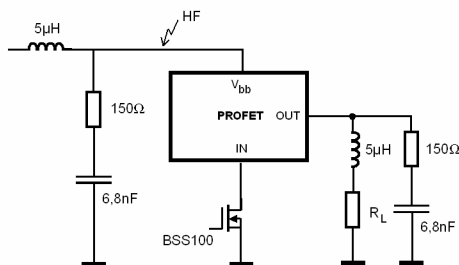
#### Typ. $V_{bb}$ -Pin Susceptibility at DC-On/Off



#### Typ. $V_{bb}$ -Pin Susceptibility at PWM-Mode

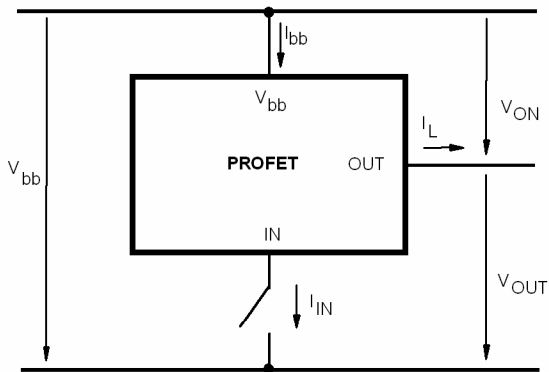


#### Test circuit:

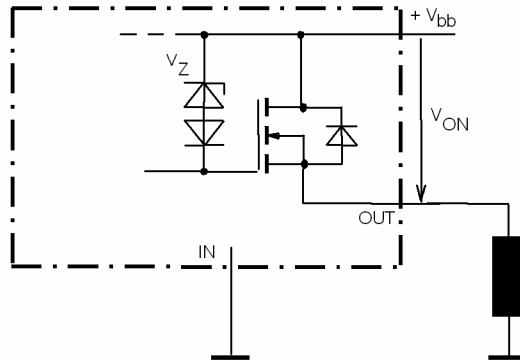


For defined decoupling and high reproducibility the same choke and the same 150Ω -matching network as for the emission measurement is used.

**Terms**

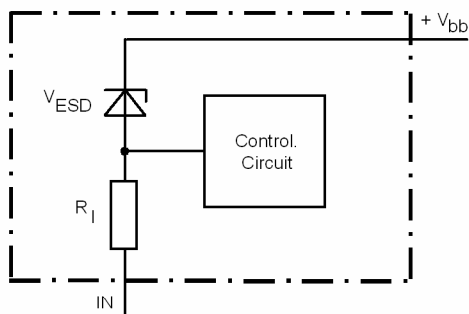


**Inductive and overvoltage output clamp**

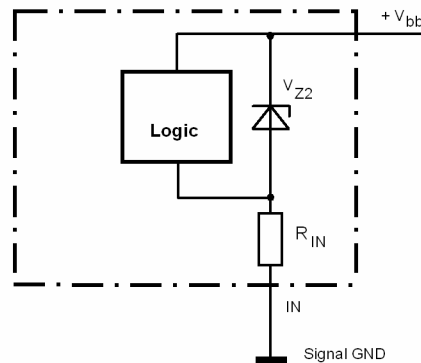


$V_{ON}$  clamped to 60 V min.

**Input circuit (ESD protection)**

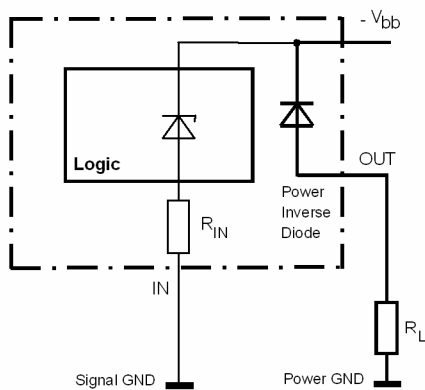


**Overvoltage protection of logic part**



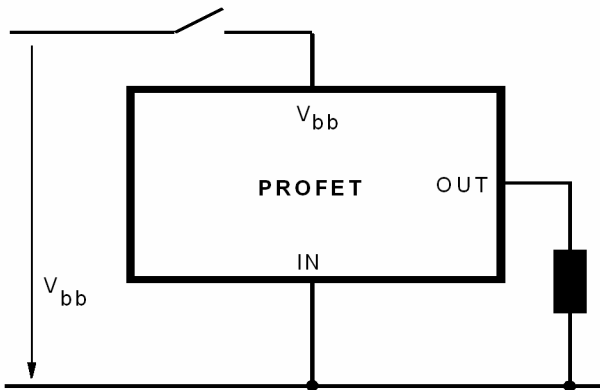
$$V_{bb,AZ} = V_{Z2} + I_{bb} * R_{IN} = 62V \text{ min.}$$

**Reverse battery protection**

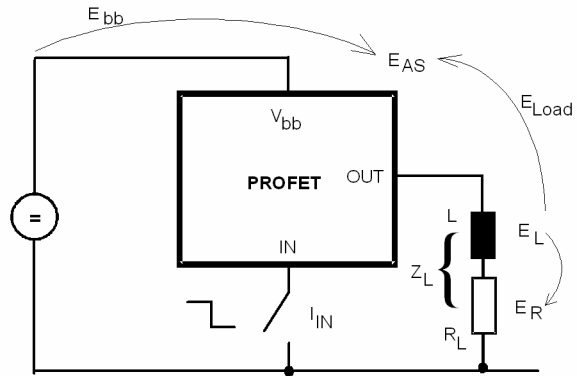


$R_I=1k\Omega$  typ., Temperature protection is not active during inverse current.

**V<sub>bb</sub> disconnect with charged inductive load**



**Inductive Load switch-off energy dissipation**



Energy stored in load inductance:  $E_L = \frac{1}{2} \cdot L \cdot I_L^2$

While demagnetizing load inductance,

the energy dissipated in PROFET is

$$E_{AS} = E_{bb} + E_L - E_R = V_{ON(CL)} \cdot \int i_L(t) dt,$$

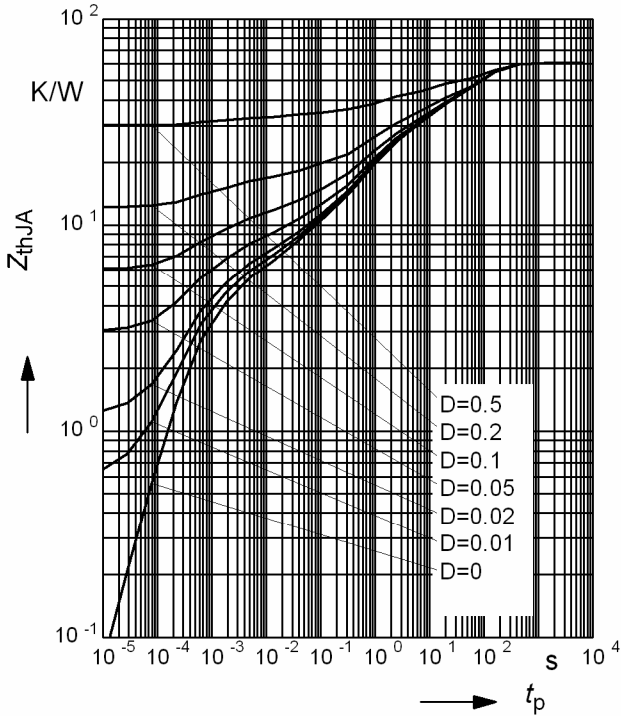
with an approximate solution for  $R_L > 0\Omega$ :

$$E_{AS} = \frac{L}{R_L} \cdot (V_{bb} + |V_{OUT(CL)}|) \cdot \left[ \frac{-|V_{OUT(CL)}|}{R_L} \cdot \ln \left( 1 + \frac{R_L \cdot I_L}{|V_{OUT(CL)}|} \right) + I_L \right]$$

**Typ. transient thermal impedance**

$Z_{thJA} = f(t_p)$  @ 6cm<sup>2</sup> heatsink area

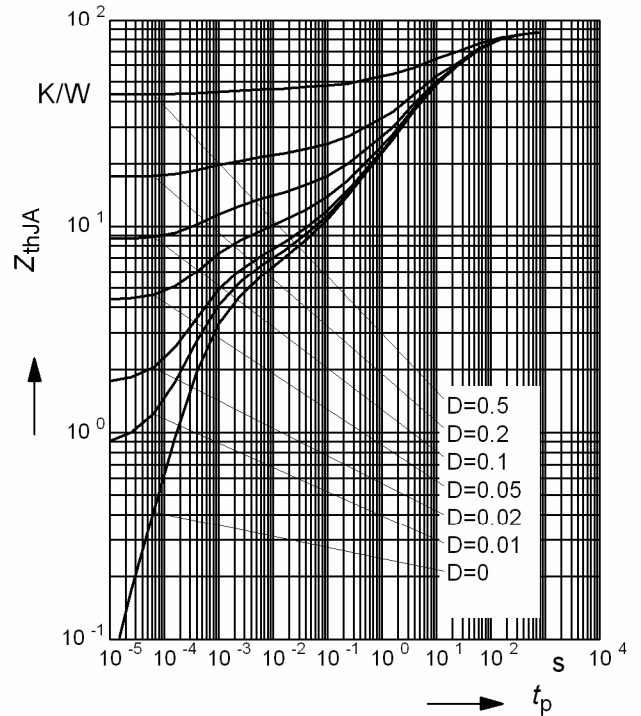
Parameter:  $D = t_p / T$



**Typ. transient thermal impedance**

$Z_{thJA} = f(t_p)$  @ min. footprint

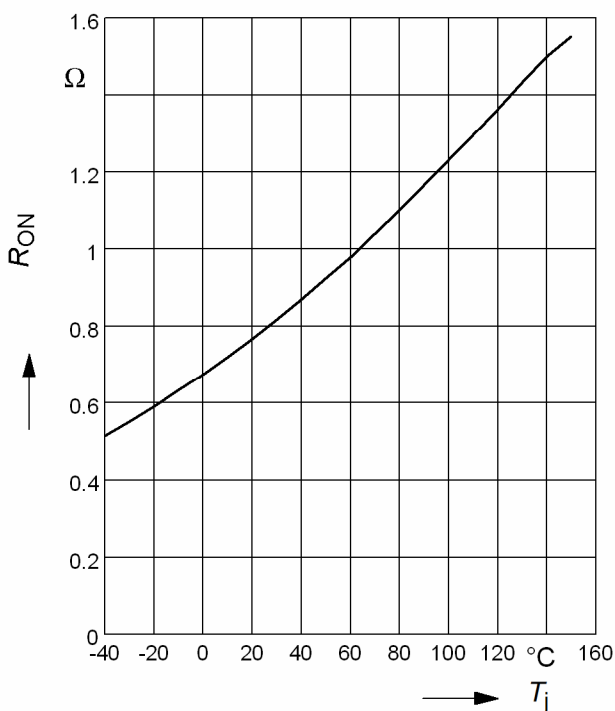
Parameter:  $D = t_p / T$



**Typ. on-state resistance**

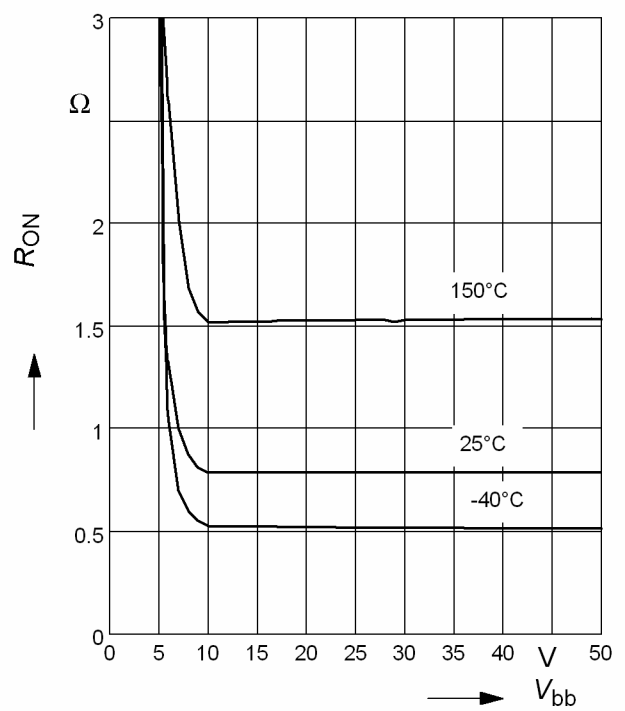
$R_{ON} = f(T_j)$ ;  $V_{bb} = 9V$ ; Pin1 grounded;

$I_L = 150mA$



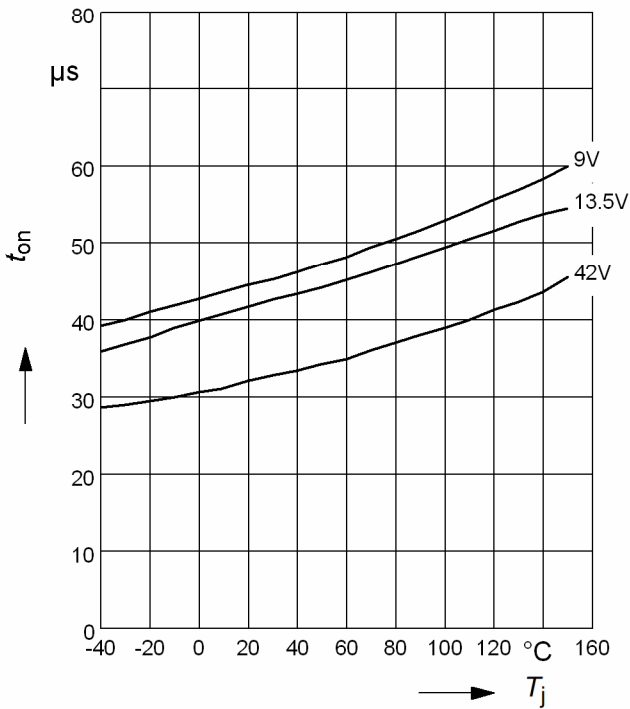
**Typ. on-state resistance**

$R_{ON} = f(V_{bb})$ ;  $I_L = 150mA$ ; Pin1 grounded



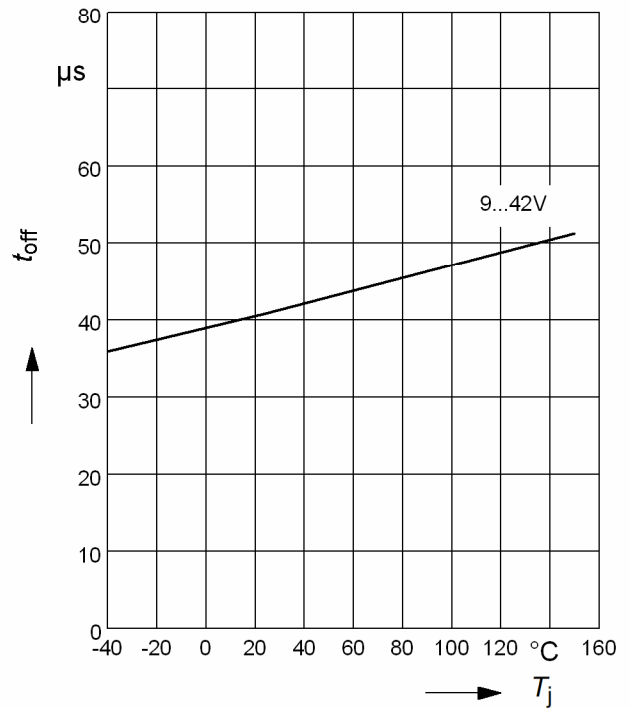
**Typ. turn on time**

$t_{on} = f(T_j); R_L = 270\Omega$



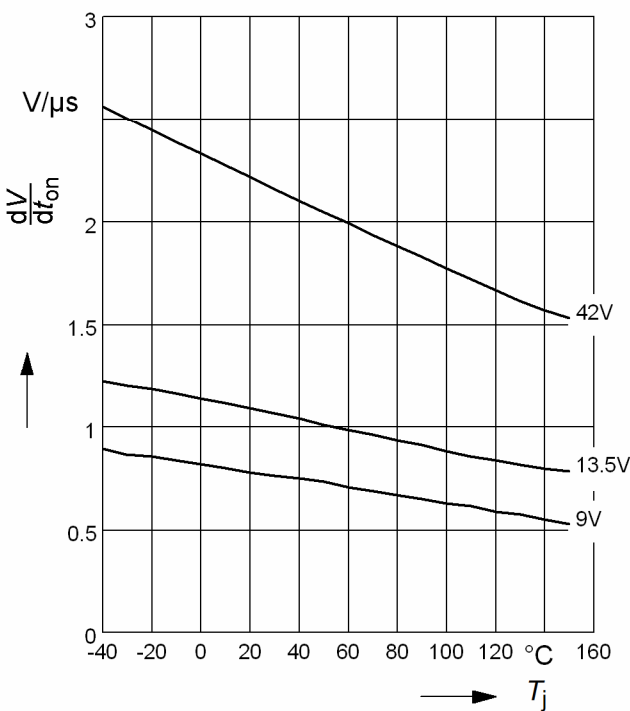
**Typ. turn off time**

$t_{off} = f(T_j); R_L = 270\Omega$



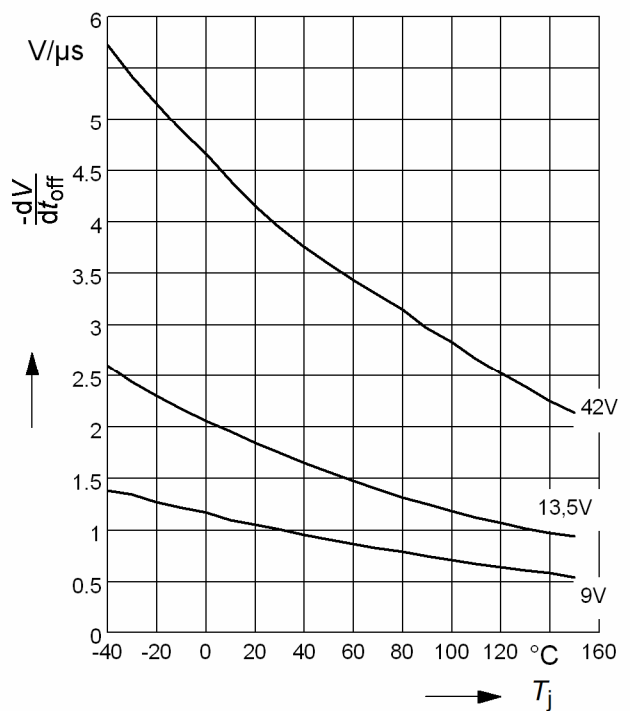
**Typ. slew rate on**

$dV/dt_{on} = f(T_j); R_L = 270\Omega$



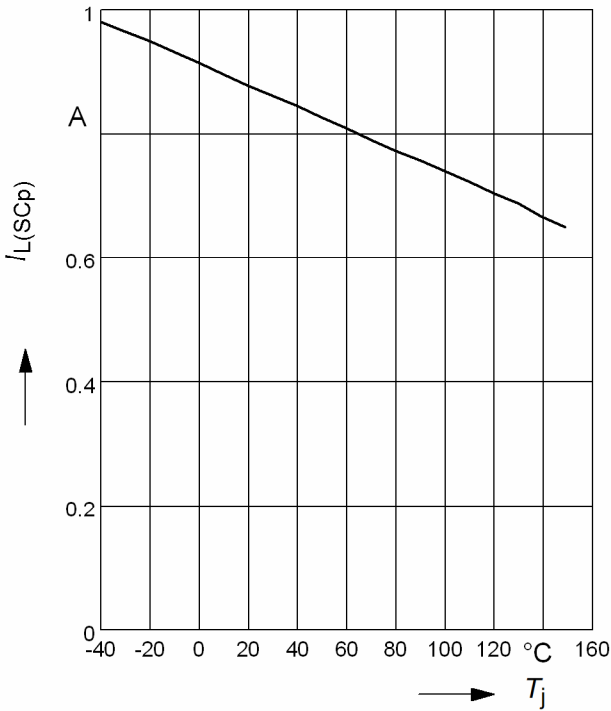
**Typ. slew rate off**

$dV/dt_{off} = f(T_j); R_L = 270\Omega$



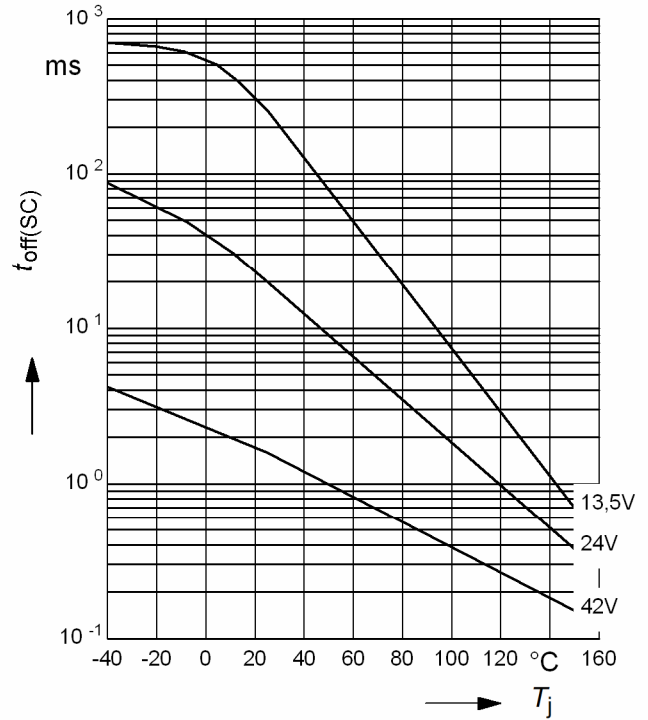
Typ. initial peak short circuit current limit

$$I_{L(SCp)} = f(T_j); V_{bb} = 13,5 \text{ V}; t_m = 100 \mu\text{s}$$



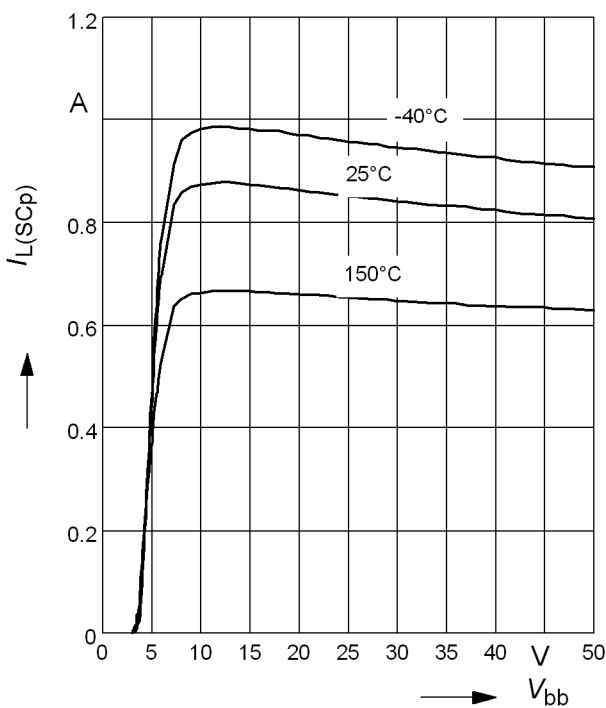
Typ. initial short circuit shutdown time

$$t_{off(SC)} = f(T_{j,start})$$



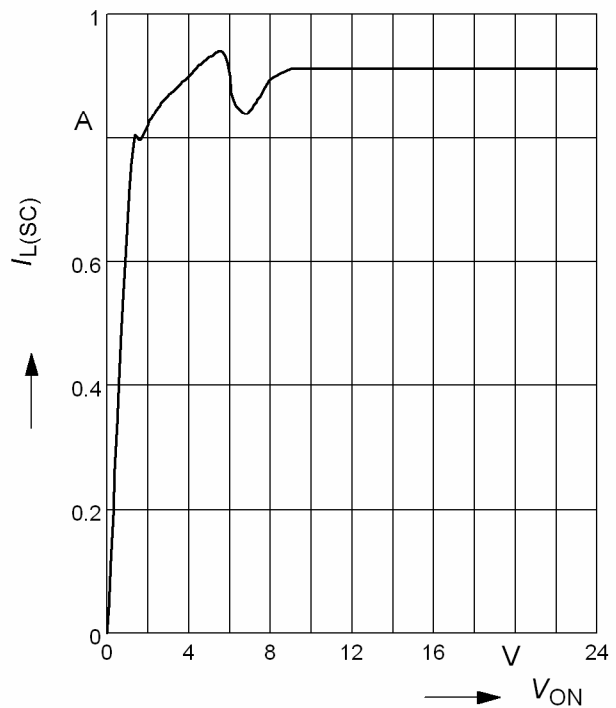
Typ. initial peak short circuit current limit

$$I_{L(SCp)} = f(V_{bb}); t_m = 100 \mu\text{s}$$



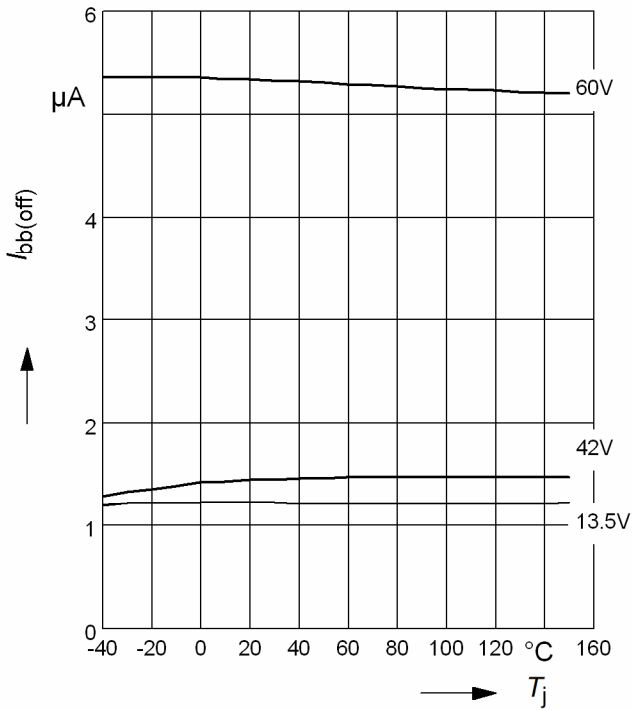
Typ. current limitation characteristic:

$$I_{L(SC)} = f(V_{ON}), V_{bb} = 13,5 \text{ V}$$



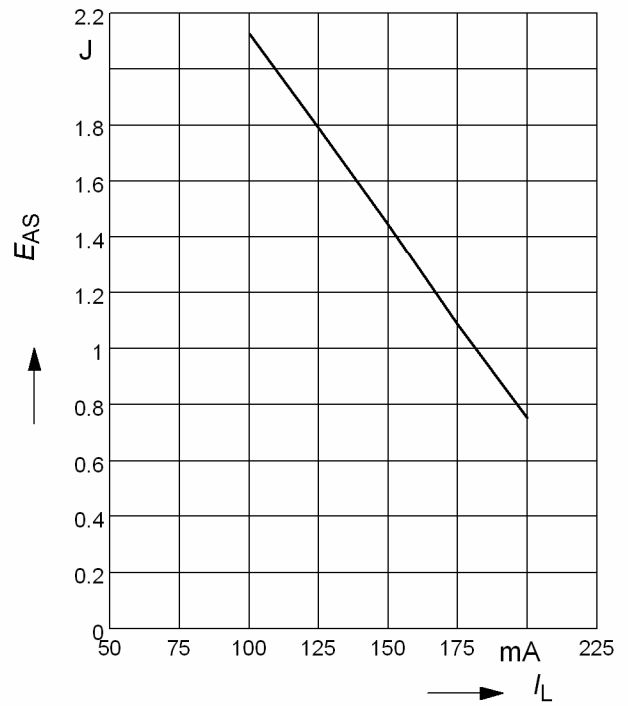
Typ. standby current

$I_{bb(off)} = f(T_j)$ ; Pin1 open



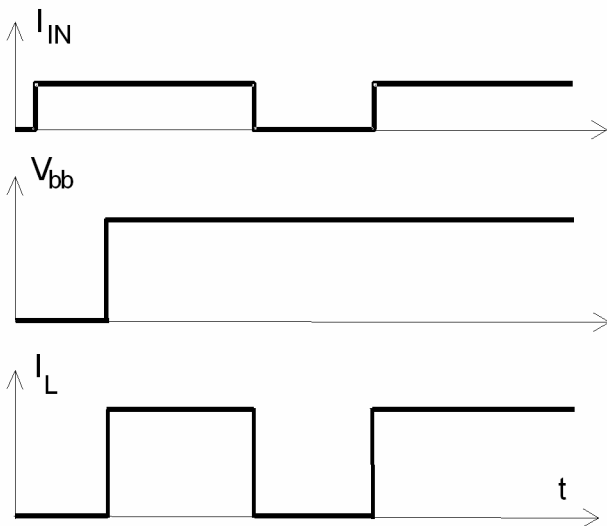
Maximum allowable inductive switch-off energy, single pulse

$E_{AS} = f(I_L)$ ;  $T_{jstart} = 150^{\circ}C$

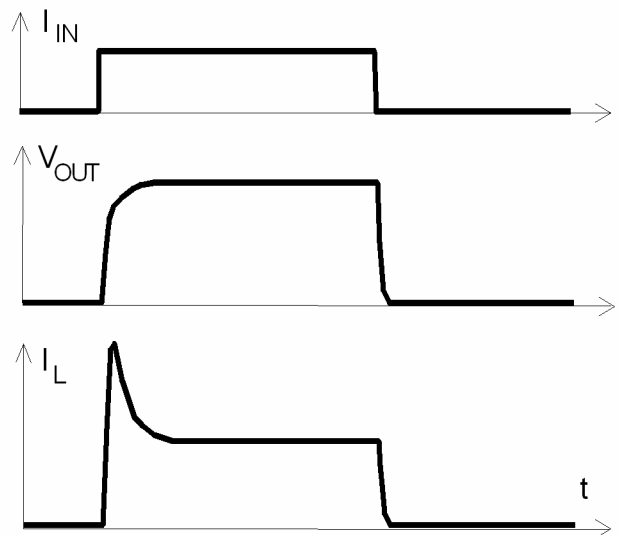


**Timing diagrams**

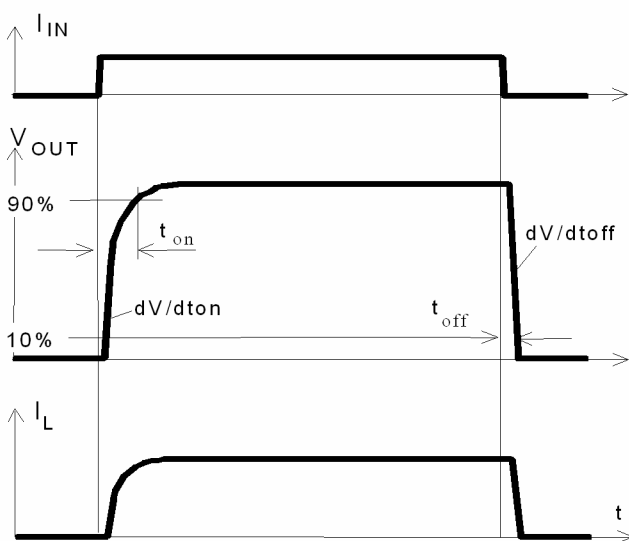
**Figure 1a: V<sub>bb</sub> turn on:**



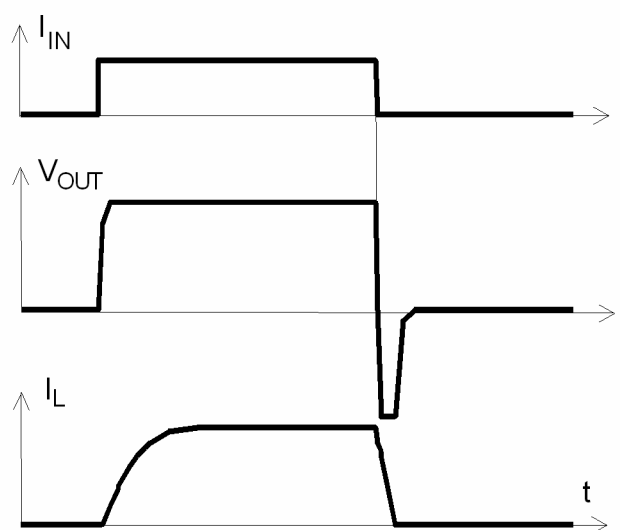
**Figure 2b: Switching a lamp**



**Figure 2a: Switching a resistive load, turn-on/off time and slew rate definition**

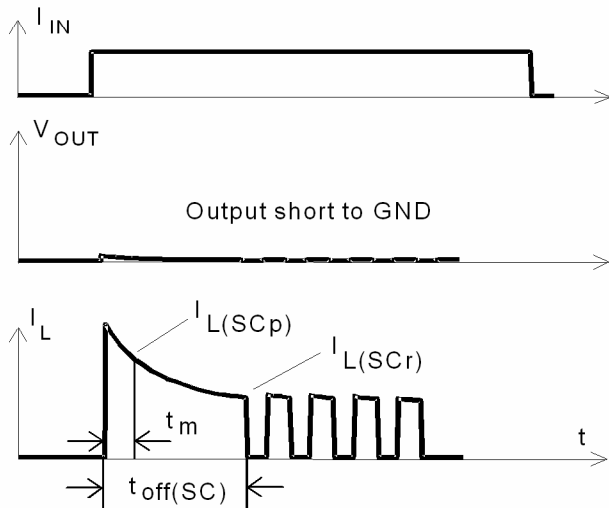


**Figure 2c: Switching an inductive load**



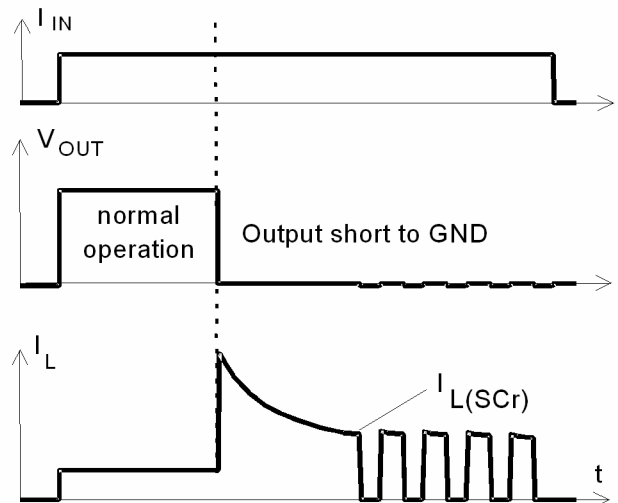


**Figure 3a:** Turn on into short circuit, shut down by overtemperature, restart by cooling

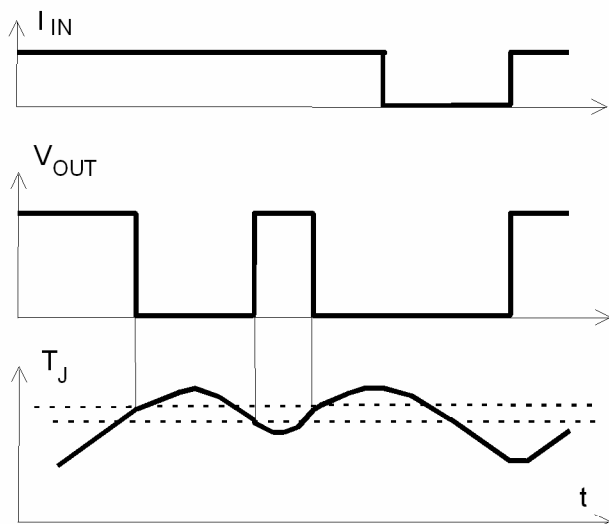


Heating up of the chip may require several milliseconds, depending on external conditions.

**Figure 3b:** Short circuit in on-state shut down by overtemperature, restart by cooling



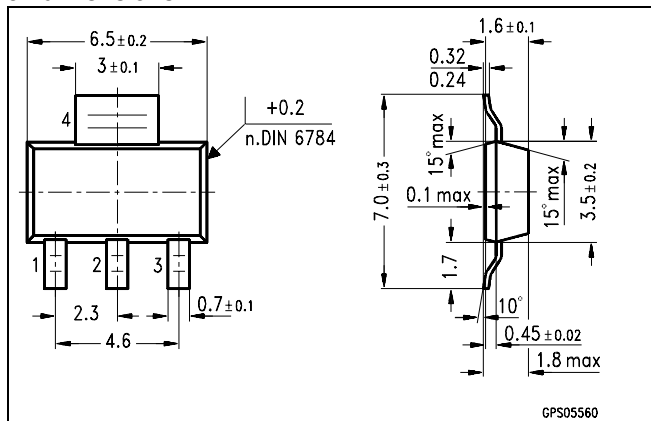
**Figure 4:** Overtemperature: Reset if  $T_j < T_{jt}$



**Package and ordering code:**

Type	Ordering code	Package
ITS 4140N	SP000240073	PG-SOT223

all dimensions in mm.


**Edition 2006-02-01**

Published by  
**Infineon Technologies AG**  
 81726 München, Germany

© Infineon Technologies AG 2006.  
 All Rights Reserved.

**Legal Disclaimer**

The information given in this document shall in no event be regarded as a guarantee of conditions or characteristics ("Beschaffenheitsgarantie"). With respect to any examples or hints given herein, any typical values stated herein and/or any information regarding the application of the device, Infineon Technologies hereby disclaims any and all warranties and liabilities of any kind, including without limitation warranties of non-infringement of intellectual property rights of any third party.

**Information**

For further information on technology, delivery terms and conditions and prices please contact your nearest Infineon Technologies Office ([www.infineon.com](http://www.infineon.com)).

**Warnings**

Due to technical requirements components may contain dangerous substances. For information on the types in question please contact your nearest Infineon Technologies Office.

Infineon Technologies Components may only be used in life-support devices or systems with the express written approval of Infineon Technologies, if a failure of such components can reasonably be expected to cause the failure of that life-support device or system, or to affect the safety or effectiveness of that device or system. Life support devices or systems are intended to be implanted in the human body, or to support and/or maintain and sustain and/or protect human life. If they fail, it is reasonable to assume that the health of the user or other persons may be endangered.

## X-ON Electronics

Largest Supplier of Electrical and Electronic Components

*Click to view similar products for [Power Switch ICs - Power Distribution](#) category:*

*Click to view products by [Infineon](#) manufacturer:*

Other Similar products are found below :

[TCK111G,LF\(S\)](#) [FPF1018](#) [DS1222](#) [TCK2065G,LF](#) [SZNCP3712ASNT3G](#) [MIC2033-05BYMT-T5](#) [MIC2033-12AYMT-T5](#) [MIC2033-05BYM6-T5](#) [SLG5NT1437VTR](#) [SZNCP3712ASNT1G](#) [DML1008LDS-7](#) [KTS1670EDA-TR](#) [KTS1640QGDV-TR](#) [KTS1641QGDV-TR](#) [U6513A](#) [MIC2012YM-TR](#) [MP5095GJ-P](#) [TPS2021IDRQ1](#) [TPS2104DBVR](#) [TPS22958NDGKR](#) [MIC2098-1YMT-TR](#) [MIC94062YMT TR](#) [MIC2015-1.2YM6 TR](#) [MIC2075-2YM](#) [MIC94068YML-TR](#) [SIP32461DB-T2-GE1](#) [NCP335FCT2G](#) [TCK105G,LF\(S\)](#) [AP2411S-13](#) [AP2151DSG-13](#) [AP2172MPG-13](#) [MIC94094YC6-TR](#) [MIC94093YC6-TR](#) [MIC94064YC6-TR](#) [MIC94061YMT-TR](#) [MIC2505-1YM](#) [MIC94085YFT-TR](#) [MIC94042YFL-TR](#) [MIC2005-1.2YM6-TR](#) [SIP32510DT-T1-GE3](#) [NCP333FCT2G](#) [BTS3050TFATMA1](#) [NCP331SNT1G](#) [TPS2092DR](#) [TPS2063DR](#) [MIC2008YML-TR](#) [MIC94084YFT-TR](#) [MIC2040-1YMM](#) [DIO1280WL12](#) [AP22814ASN-7](#)