

TriBoard Manual TC3X9

Hardware: TriBoard TC3X9 TH V1.0(1) and TriBoard TC3X9 V1.0

About this document

Scope and purpose

The User Manual provide information about using, configuration and connecting the TriBoard with Infineon AURIX™ TC3X9 device. The manual provide information for different hardware types. There exist different hardware with Through Hole socket (TriBoard TC3X9 TH) and soldered devices (TriBoard TC3X9). The schematic is identically for the all boards if not other mentioned in chapter schematic. The placing on the boards is slightly different around the TC3X9 itself dependent of the space (socket need more space and has through hole), but the most components are on the same location. All figures are valid for each board if not differently mentioned.

Intended audience

Design, verification, test and software engineers will use this document to get an understanding of the functionality and connections of the TriBoard.

Table of Contents

	About this document	Preface-1
	Table of Contents	TOC-2
1	Introduction	1-1
2	Features	2-1
2.1	Summary of Features	2-1
2.2	Block Diagram	2-3
2.3	Placement	2-4
3	TriBoard Information	3-1
3.1	Power Supply	3-1
3.1.1	Failsafe handling	3-1
3.2	LEDs	3-2
3.3	Clock	3-2
3.4	Memory (not with TC3X7)	3-2
3.4.1	Flash	3-3
3.4.2	SRAM	3-3
3.5	USB Connector	3-3
3.5.1	Serial Connection to PC	3-3
3.5.2	miniWiggler JDS	3-4
3.6	FlexRay™ (E-RAY)	3-4
3.7	Serial Eeprom	3-5
3.8	MultiCAN	3-5
3.9	LIN	3-5
3.10	Ethernet	3-5
3.11	HSCT (optional)	3-6
3.11.1	High speed with HSCT	3-6
3.12	Other peripherals	3-6
3.13	Toggle LED's	3-7
3.14	Buttons	3-7
3.15	Debug System	3-7
3.15.1	OCDS1	3-7
3.15.2	DAP	3-7
3.15.3	DAPE (only Emulation Device)	3-7
3.15.4	High speed with DAP/DAPE	3-7
3.15.5	AGBT (optional)	3-9
3.15.6	ETK connector (optional)	3-9
3.15.7	EmW Power (optional)	3-9
4	TriBoard Configuration	4-1
4.1	HW Boot Configuration	4-1
4.1.1	Default Pad State	4-1
4.1.2	Bootmode	4-1
4.2	Assembly Options	4-2
4.2.1	General optional resistors	4-2
4.2.2	Resistors for peripherals	4-4
4.2.3	Resistors for memories	4-6
5	Signal (on board used) Description	5-1
5.1	Power Signals	5-1

Table of Contents

5.2	Reset Signals	5-1
5.3	Config Signals	5-2
5.4	Clock Signals	5-2
5.5	Debug Signals	5-2
5.6	Peripheral Signals	5-3
5.7	EBU Signals	5-4
6	Connector Pin Assignment	6-1
6.1	On Board only used signals	6-1
6.2	TC3X9 Connector / Top View	6-2
6.3	Power connector pinout	6-5
6.4	USB connector pinout	6-5
6.5	FlexRay™ (ERAY) connector pinout	6-5
6.6	CAN connector pinout	6-5
6.7	LIN connector pinout	6-6
6.8	HSCT connector pinout	6-6
6.9	Ethernet connector pinout	6-6
6.10	OCDS1 connector pinout	6-7
6.11	DAP connector pinout	6-7
6.12	ETK connector pinout	6-8
6.13	Ethernet miniWiggler power connector pinout	6-8
6.14	AGBT connector pinout	6-9
7	Schematic and Layout	7-1
7.1	Known problems	7-1
7.1.1	Known problems (TriBoard TC3X9 TH V1.0)	7-1
7.1.2	Known problems (TriBoard TC3X9 TH V1.01)	7-1
7.1.3	Known problems (TriBoard TC3X9 V1.0)	7-1
7.2	Schematic	7-1
7.3	Layout	7-10
7.4	Layout with Dimensioning	7-14

Introduction

1 Introduction

We congratulate you on your purchase of the TriCore Evaluation Board. This kit is a versatile tool, providing quick access to the capabilities of TriCore's powerful architecture.

Applications can be developed easily. The Evaluation Board is equipped with a variety of memories and peripherals for connection to the environment. There is also an interface for the On Chip Debugging Features (OCDS1 and DAP).

The Evaluation Board allows easily the development of TriCore applications with the corresponding tools.

Subsequently, the applications can be downloaded and can be tested with the powerful debugger software.

This TriBoard Hardware Manual familiarizes you with the TriCore Evaluation Board and guides you through the initial configuration of the TriBoard.

For detailed technical information about the TC3X9 (e.g. TC399) please refer to the User Manual of the used device.

Features**2 Features****2.1 Summary of Features**

- Infineon’s TC3X9 (TC399) AURIX™ 2G Controller in LFBGA-516 Package
- Infineon’s TC3X7 (TC397) AURIX™ 2G Controller in LFBGA-292 Package
- Burst Flash up to 4MBytes (not with TC3X7)
- asynchronous SRAM up to 2MByte (not with TC3X7)
- synchronous SRAM up to 4MByte (not with TC3X7)
- FlexRay™¹⁾ Transceivers
- High Speed CAN Transceivers (CAN-FD capable)
- USB to UART bridge
- Ethernet Gigabit PHY
- Serial Eeprom
- LIN Transceiver
- Crystal 20MHz (default) or External Clock
- USB miniWiggler JDS for easy debugging
- 8 Low Power Status LEDs
- 8-DIP switches for configuration
- access to all pins of controller
- 100mm x 160mm (EURO-Board)

Connectors

The TC3X9 TriBoard offers a wide variety of connectors:

- Standard power connector
- Micro USB connector for ASC Interface (ASC0) and miniWiggler
- RJ45 connector for Ethernet
- 16-pin header for JTAG interface (OCDS)
- 2 x 10-pin header for DAP and DAPE (DAPE only usable on Emulation Device)
- 10pin (2x5) Header for LIN Transceiver (LIN)
- 2 x 10pin (2x5) Header for CAN High Speed Transceiver (CAN0 and CAN1)
- 2 x 10pin (2x5) Header for FlexRay™ (ERAY-A and ERAY-B)
- five 80-pin connectors (male) + five 80-pin connectors (female) with all I/O signals
- optional ETK connector
- optional 6pin (IEEE1394) Socket for HSCT
- optional Aurora connector (only with Emulation Device)

Components

- Infineon’s Multi Voltage Safety Micro Processor Supply TLF35584QV
- Three LEDs to validate power supply (5Volt / 3,3 Volt / 1,25 Volt)
- LED indicating safe state signal 2 from TLF35584
- LED indicating /HDRST (ESR0) active state
- LED indicating activ miniWiggler JDS
- LED switched via DAS software
- 2 x Infineon’s FlexRay™ Transceiver TLE9221SX
- 2 x Infineon’s High Speed CAN-Transceiver TLE9251VSJ

1) FlexRay™ is a trademark of FlexRay Consortium.

Features

- Infineon's LIN-Transceiver TLE 7259-3GE
- USB to UART bridge FT2232HL (FTDI)
- Single Port Gigabit Ethernet PHY PEF7071 (LANTIQ)
- 8 general purpose LEDs
- 2K I²C Serial Eeprom with EUI-48™¹⁾ Node Identity (MICROCHIP)
- Reset switch
- Enable switch
- Generic switch
- 4-pin Dip switch

Zero Ohm Bridges

Zero Ohm resistors give the flexibility to configure the systems functionality.

1) EUI-48™ is trademarked by IEEE

Features

2.2 Block Diagram

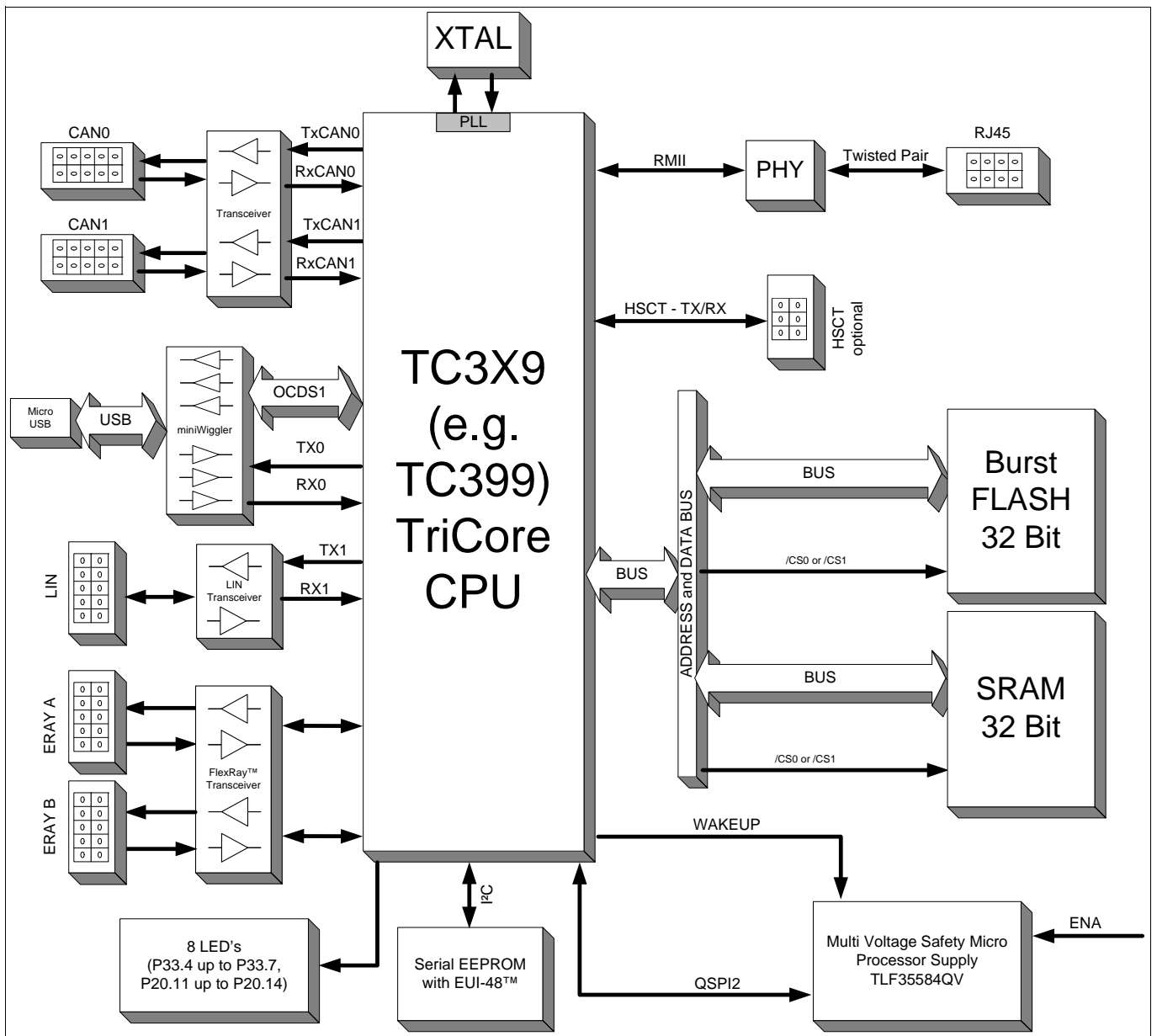

Figure 2-1 TriBoard Block Schematic

Features

2.3 Placement

Note: On soldered board the DAP connector (X402) and the crystal (Y201) are located closer to the TC3X9 (U201) as shown in [Figure 2-2](#) other components are on the same location (see also [Figure 7-12](#)).

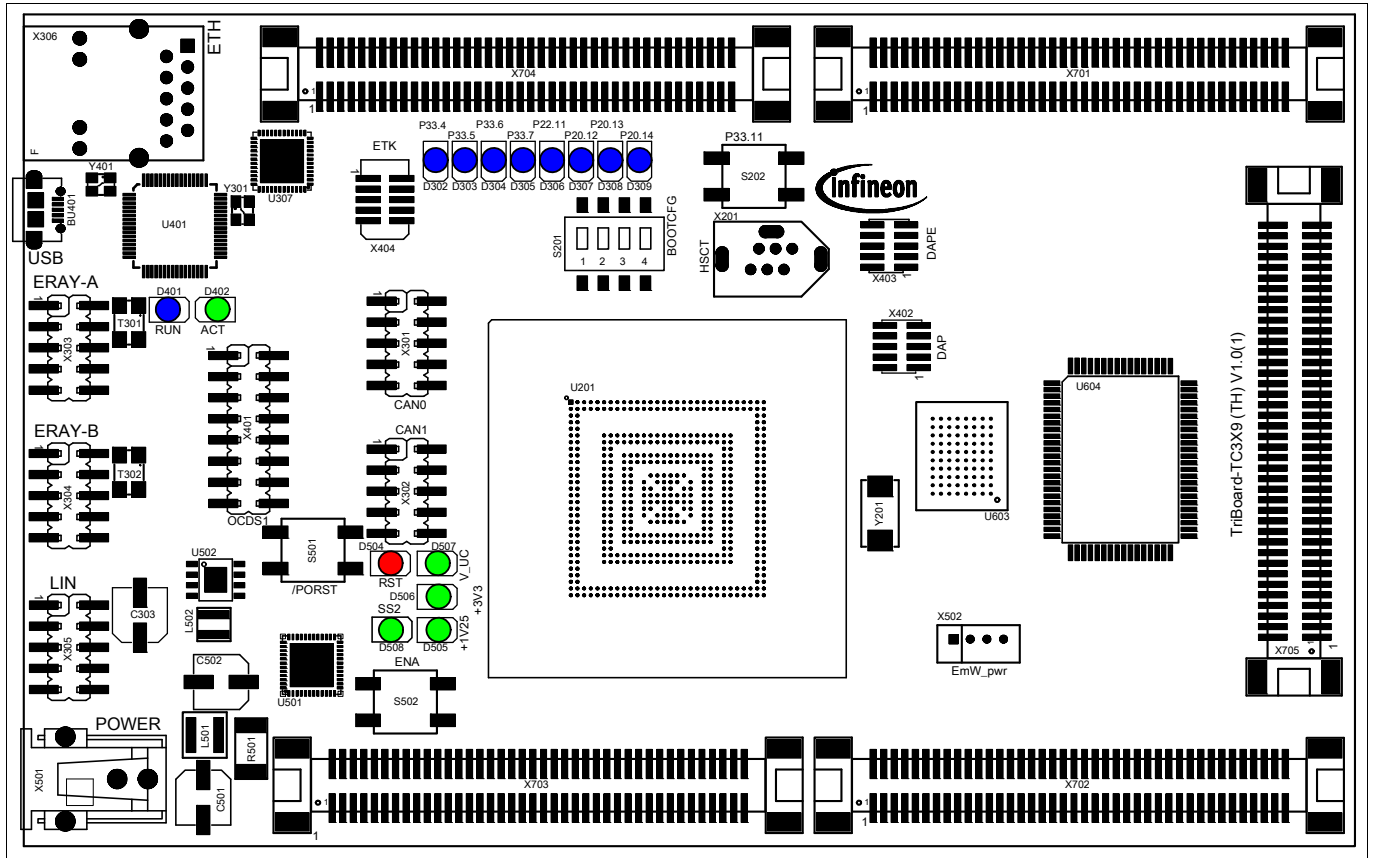

Figure 2-2 TriBoard TC3X9 (TH) V1.0(1) Placement

3 TriBoard Information

3.1 Power Supply

All needed voltages are generated via Infineon's Multi Voltage Safety Micro Processor Supply TLF35584QV and via the microcontroller itself (+1,25V).

The supply device is available as two different devices:

TLF35584QVWS1 -> +5V standby voltage, +5V TriCore supply (V_UC)

TLF35584QVWS2 -> +3,3V standby voltage, +3,3V TriCore supply (V_UC)

Dependent of the assembled device the board works with 5V or 3,3V IO.

The TLF35584QV provide the following voltages:

+3,3V or +5V for standby (connected to VEVRSB)

+3,3V or +5V for TriCore (connected to VEXT)

+5V communication supply (used by CAN and FlexRay™ transceivers)

+5V voltage reference (connected to VDDM and VAREFx)

+3,3V via LDO directly from pre regulator (used by Ethernet PHY and on board memories)

Applying a stable supply voltage causes the power on reset after a short period. The three LED's (V_UC, +3.3V, +1V25) indicate the status of the on board generated voltages.

A manual power on reset is executed by pressing the reset button.

The Board has to be connected to a +3,5V to +40V DC power supply.

The power consumption is not specified yet but a supply with 12V and 500mA is recommended. The pinout for the supply connector is shown in [Figure 6-4](#). There can be used any standard power pack with a connector where the positive line is surrounded by the ground line.

3.1.1 Failsafe handling

In case that the device don't contains a program which disable or service the window watchdog and error pin monitor of the TLF35584 then the TLF35584 is going to a FAILSAFE state where all supplies are switched off. This state can be left via reconnect the power plug or via the ENA button (S502). In this case you must connect a debugger which is able to disable the window watchdog and error pin monitor to reprogram the microcontroller.

In the default state of the board the switching to FAILSAFE state is switched off via resistor R508. Beginning with schematic V1.02 R509 is assembled with 20K and R508 with 0R. If only R508 or R509 assembled then the board is manufactured with earlier Version (V1.01). In this case you should remove R509 (if assembled) or change R509 to 20K and assemble R508 with 0R to avoid the FAILSAFE state and switching off the supplies.

If you will use/evaluate all safety features of the TLF35584 make sure that R509 is assembled and R508 is not assembled. Make sure that you have a proper initialization of TLF35584 in your software.

Resistor R508 and R509 are red marked in the following [Figure 3-1](#):

TriBoard Information

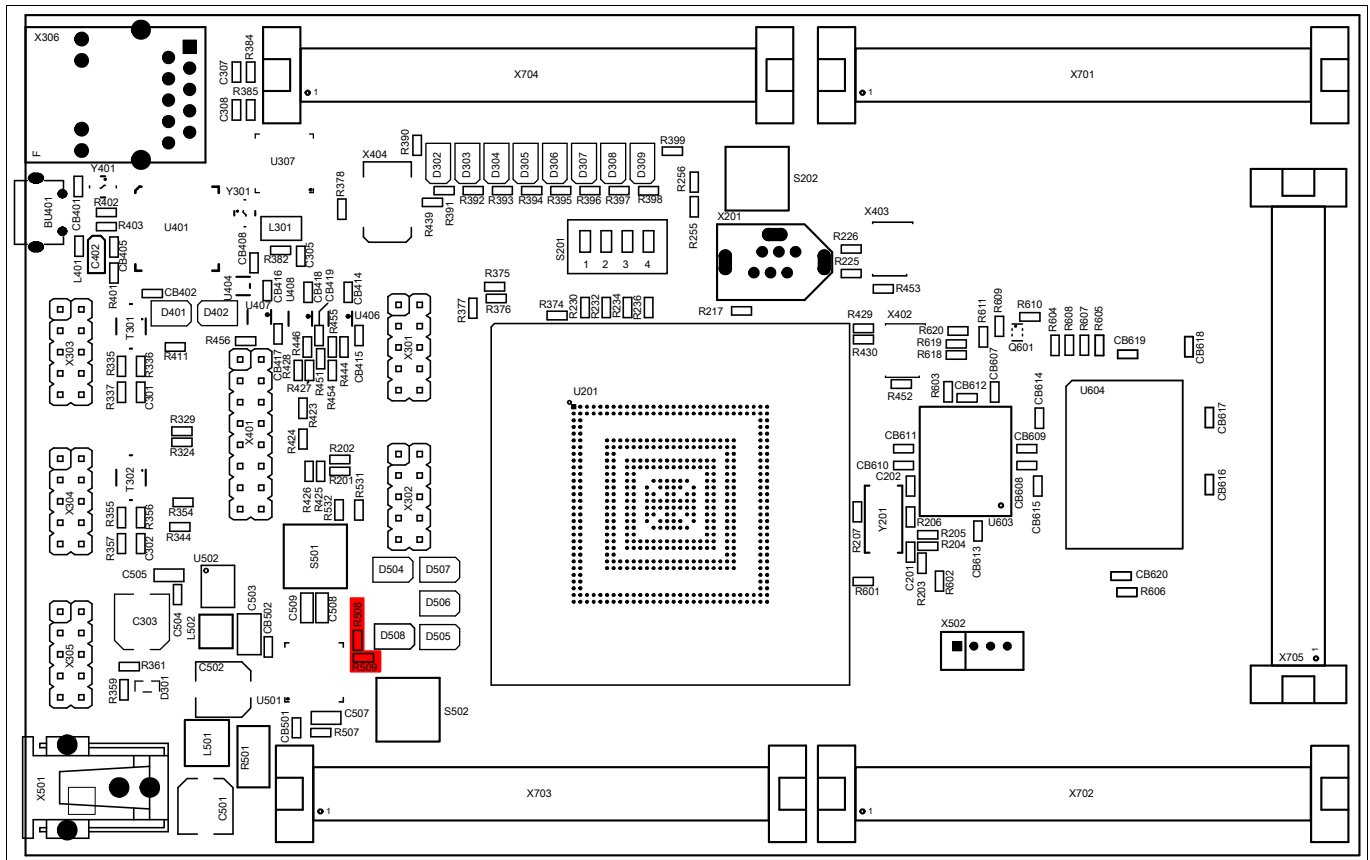

Figure 3-1 Resistors for TLF35584 Safety feature handling with switch on

3.2 LEDs

There are 15 LEDs on board:

- D302 up to D305 (blue) -> toggle LEDs connected to P33.4 ... P33.7
- D306 up to D309 (blue) -> toggle LEDs connected to P20.11 ... P20.14
- D504 RST (red) -> RESET LED indicate the reset state of the board (/ESR0)
- D505 +1V25 (green) -> +1V25 power supply indication
- D506 +3V3 (green) -> +3,3V power supply indication
- D507 V_UC (green) -> +5V/+3,3V power supply indication
- D508 SS2 (green) -> safe state signal 2 indication
- D402 ACT (green) -> on board miniWiggler JDS is ACTIV
- D401 RUN (blue) -> Debug RUN mode (switched by DAS Server)

3.3 Clock

On the board is a fixed crystal with 20MHz assembled. You can change this by replacing Y101 (soldered).

3.4 Memory (not with TC3X7)

The TriBoard supports the following memory configurations:

- up to 4 MBytes external Burst Flash (1x32Bit) or
- up to 2 MBytes external asynchronous SRAM (2x16Bit) or
- up to 4 MBytes external synchronous SRAM (1x32Bit) or
- up to 1 MBytes external asynchronous SRAM (1x16Bit)

TriBoard Information

For the On Board Memory are reserved chip select 0 and 1. Therefore only two parts, e.g. 1x32Bit Flash and 2x16Bit asynchronous SRAM, should be assembled and can be used at the same time. Chip Select 2 is used as Burst Address Advance output on the board and can be used externally only if the flash and the synchronous SRAM (if assembled) are not used in burst mode.

3.4.1 Flash

The flash uses 32 Data Bits (AD0...AD31) and 20 Address Bits (A0...A19). It's accessed via /CS0 or /CS1. The flash has its own resistor to connect to /CS0 or /CS1. To connect the flash see [Table 4-4](#).

Note: Only +3,3V Flash is usable with this board.

3.4.2 SRAM

The SRAM uses 32 Data Bits (AD0...AD31) and up to 20 Address Bits (A0...A19).

It's accessed via /CS0 or /CS1. Each type of SRAM has its own resistor to connect to /CS0 or /CS1. To connect different SRAMs see [Table 4-4](#).

Note: Only +3,3V SRAM is usable with this board.

3.5 USB Connector

The USB connector is used for connection to a PC. Via the USB it is possible to power the board, using the ASCLIN0 as serial connection via USB and Debugging via DAS. For the pinout of USB socket see [Figure 6-5](#).

NOTE: Before connecting the board to the PC, make sure that the actual DAS software is installed on the PC. For actual DAS software please contact your local FAE.

The software can also be found on:

[**DAS website**](#)

3.5.1 Serial Connection to PC

After the first connection of USB to a PC the needed driver will be installed automatically. During this there will be created a new COM port on PC. This COM port can be used to communicate with the board via ASCLIN0 of the device. Per default the ASCLIN0 is used on P14.0 and P14.1 (e.g. Generic Bootstrap Loader) . In case you will use the Generic Bootstrap Loader via CAN or ASCLIN0 via P15.2 and P15.3 you must:

- remove R436 and R437 (this disconnect the serial connection from P14.0 and P14.1)
- remove R301 and R302 (this disconnect the CAN0 transceiver from P20.7 and P20.8)
- assemble R438 and R440 with 0R resistor (size 0603) to connect P15.2 and P15.3 to serial connection
- assemble R303 and R304 with 0R resistor (size 0603) to connect P14.0 and P14.1 to CAN0 transceiver

The mentioned resistors are red marked in [Figure 3-2](#).

TriBoard Information

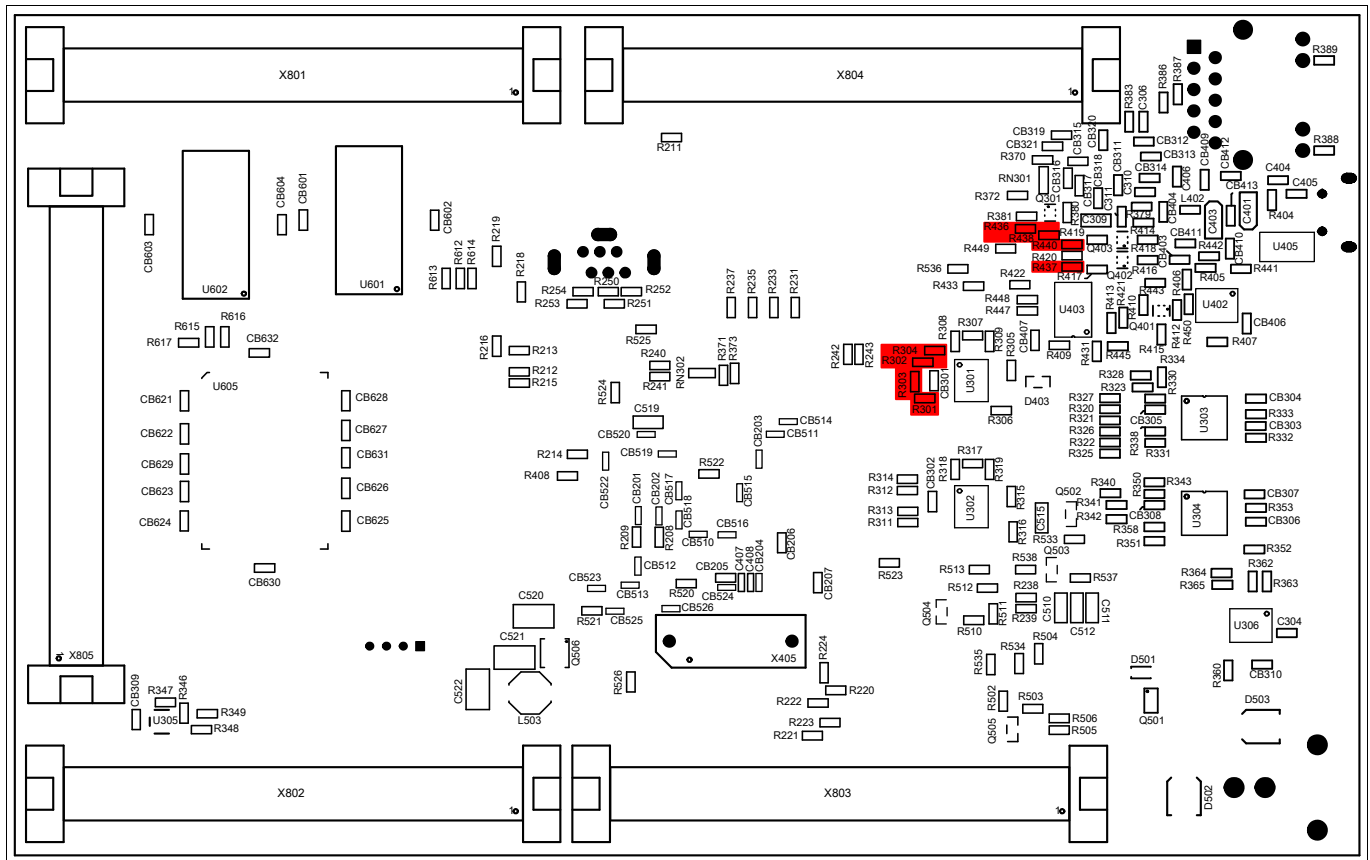

Figure 3-2 Resistors for ASC connection (ASC0)

3.5.2 miniWiggler JDS

The miniWiggler JDS is a low cost debug tool which allows you access to the JTAG of the device. Make sure that you have the latest DAS release. Debugging is possible via the DAS Server ‘UDAS’. Please contact your preferred debug vendor for support of DAS.

If you have connected the board to the PC and there runs the DAS server, then a working connection is visible via the green ACTIV LED.

The status RUN LED is switched on/off through the DAS Server, depending on the used debugger (client).

IMPORTANT: Make sure that there is no or a tristated connection on X401 (OCDS1) and X402 (DAP) if the ACTIV LED is on.

Per default the miniWiggler is connected to the DAP. It is possible to change the connection to DAPE (DAP of emulation device if available). If resistors R214, R215 and R216 assembled (default) then the standard DAP is connected to miniWiggler otherwise if R217, R218 and R219 are assembled the the DAPE of emulation device is connected to miniWiggler. Please note that there should be connected only standard DAP or DAPE. If all this resistors are not assembled then the miniWiggler can’t be used. In this case only the DAP connectors X402 and X403 can be used. See [Table 3-4](#) and [Table 3-5](#).

3.6 FlexRay™ (E-RAY)

The board has 2 IDC10 plugs for FlexRay™ Communication (channel A and B) with up to 10 Mbit/s. For the pinout of the plugs see [Figure 6-6](#). You can use a IDC female connector with crimpconnector, flat cable and SUB-D 9 plug with crimpconnector to have a 1:1 adapter to SUB-D 9.

The transceiver are connected to the TriCore device via zero ohm resistors (R325 up to R329 and R340 up to R344) which must be removed to use the ports outside.

TriBoard Information

ERAY-A can be connected to P14.8, P14.9 and P14.10 (default, usable with ERAY0 and ERAY1) and to P02.0, P02.1 and P02.4 (only usable with ERAY0). Transceiver for channel A can be enabled/disabled via P32.3 (default) or via P10.2. The error state of transceiver channel A can be read out via P32.2 (default) or via P10.1.

ERAY-B is connected to P14.5, P14.6 and P14.7 (default, usable with ERAY0 and ERAY1). Transceiver for channel A can be enabled/disabled via P20.10 (default). The error state of transceiver channel A can be read out via P20.9 (default).

For more information look in the user manual for TC3X9.

3.7 Serial Eeprom

The I²C via P15.4 and P15.5 of the TC3X9 is connected to a serial EEPROM with a size of 2KBit (2 x 128 x 8). The slave address of this EEPROM is 0x50. The upper half of the array (80h-FFh) is permanently write-protected. Write operations to this address range are inhibited. Read operations are not affected. This upper half contains a pre-programmed EUI-48™ node address which can be used as MAC ID for Ethernet. The other 128 bytes are writable by customer.

To disconnect (disable) the EEPROM remove resistor R348 and R349.

3.8 MultiCAN

On the board are two CAN transceiver connected to the CAN0 and CAN1 of TC3X9. The transceivers are connected to two IDC10 plug. For the pinout of IDC10 plug see [Figure 6-7](#). You can use a IDC female connector with crimpconnector, flat cable and SUB-D 9 plug with crimpconnector to have a 1:1 adapter to SUB-D 9.

The transceiver are connected to the TriCore device via zero ohm resistors (R301 up to R304 and R311 up to R314) which must be removed to use the ports outside.

CAN0 can be used via P20.7 and P20.8 (node 0, default) or P14.0 and P14.1 (node 1). CAN1 can be used via P23.0 and P23.1 (node 0, default) or P00.0 and P00.1 (node 0).

3.9 LIN

On the board is one LIN transceiver connected to the ASCLIN1 on TC3X9 (P15.0 and P15.1). The transceiver are connected to one IDC10 plug. For the pinout of IDC10 plug see [Figure 6-8](#). You can use a IDC female connector with crimpconnector, flat cable and SUB-D 9 plug with crimpconnector to have a 1:1 adapter to SUB-D 9.

To disconnect the LIN remove resistor R364 and R365.

3.10 Ethernet

The TriBoard provide a RJ45 connector (X306) for twisted pair ethernet connections. The TriBoard use a Lantiq Gigabit PHY PEF7071 as physical interface device. For more information about the ethernet modul see TC3X9 User's Manual, about the PHY see the PEF7071 datasheet. For the pinout of RJ45 see [Figure 6-10](#).

The PHY is connected to the TriCore device via resistors and resistor arrays (R370 up to R377 and RN301 up to RN302) which must be removed to use the ports outside.

For the connection between TriCore and PHY can be used RMII (default).

Please note that the RGMII interface can't be used also if the TriCore device is able to have a RGMII connection. Therefore Gigabit is not usable with this board only 10M and 100M.

Note: Please note that the PHY is always waked up in RGMII mode and must be reprogrammed to RMII if needed via MDC and MDIO (P12.0 and P12.1). In the case that you need that the PHY wakeup in RMII then replace R384 with 3K3 and R385 with 5K1.

TriBoard Information

3.11 HSCT (optional)

The TriBoard provide a footprint of IEEE 1394 socket (X201) for connection to other TC3XX via HSCT.

Note: Don't use X201 for connection to any IEEE 1394 device, this can destroy the board and/or the connected device.

For connect two TriBoards you need to assemble this socket (Lumberg 2415 01) on each board and connect the boards with a standard 6 pin IEEE 1394 cable. For the pinout of socket see [Figure 6-9](#).

3.11.1 High speed with HSCT

For use the HSCT connection between two board you need to remove 5 resistors to have a very short connection between device and connector. On the TC3X9 Triboard this 5 resistors are R250, R251, R252, R253 and R254 (red marked in [Figure 3-3](#)). This resistors needs to be removed.

Important: When the resistors are removed then the port signals P20.0, P21.2, P21.3, P21.4 and P21.5 are no longer available on the 80 pin samtec connectors.

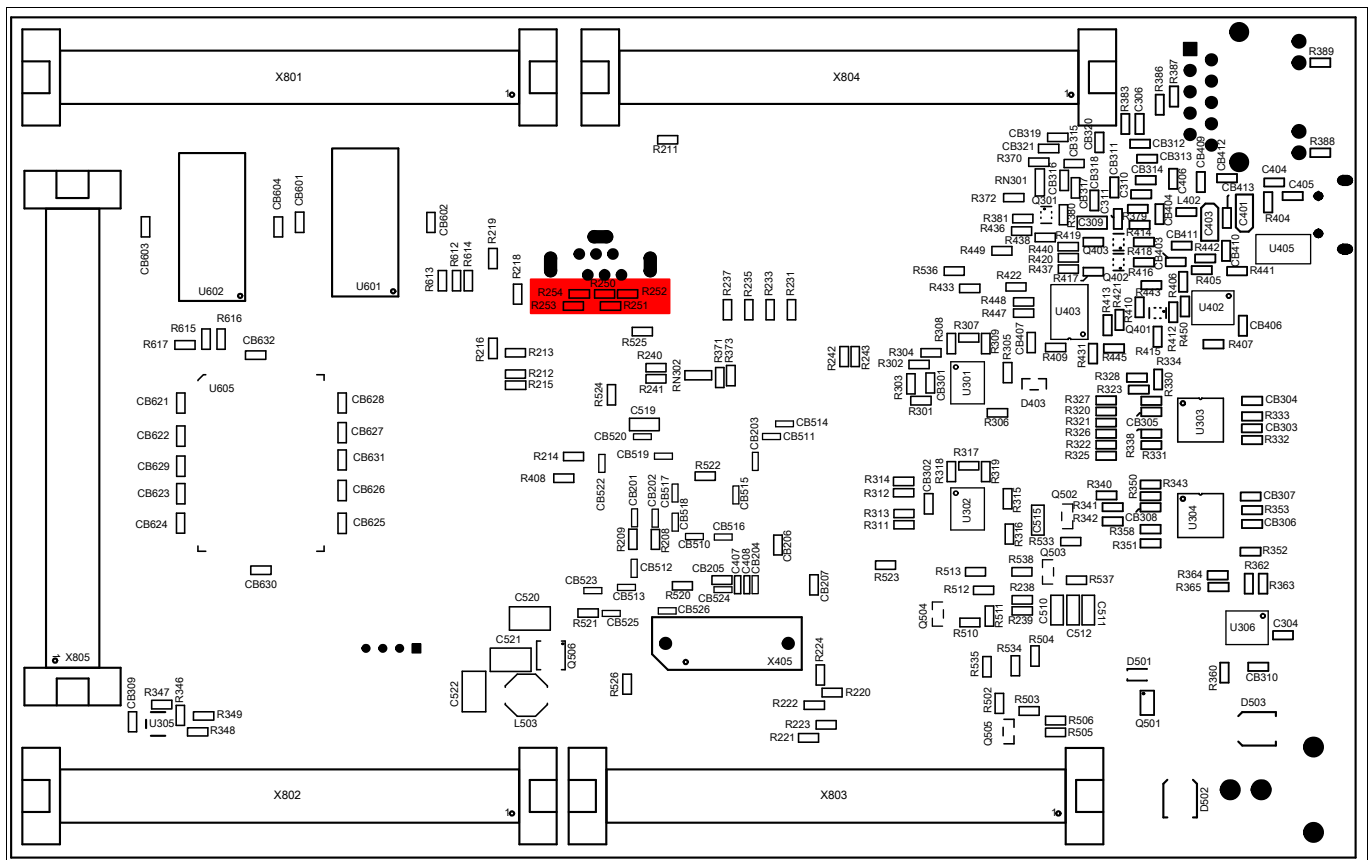

Figure 3-3 Resistors for high speed HSCT

3.12 Other peripherals

For all other peripherals there are no special plugs on the board. The peripheral signals are available on the different connectors. See [“Connector Pin Assignment” on Page 6-1](#).

TriBoard Information**3.13 Toggle LED's**

The status LED's are low active and can be controlled by Software.

Port 20 pin 11 up to pin 14 are connected to single LED's (D306... D309) and powered by the normal microcontroller voltage.

Port 33 pin 4 up to pin 7 are connected to single LED's (D302... D305) and powered by the standby voltage. This means that this LED's can be active also when the board is in standby mode and only the standby voltage available (port 33 is powered by VEVR SB pin which is connected to standby supply of TLF35584). In this case the port pins are controlled by the standby controller if available.

3.14 Buttons

On the board are three buttons.

The reset button (S501) will apply a warm power on reset to the device.

The ENA button (S502) will be used to enable/wakeup the TLF35584.

The P33.11 button (S202) can be used by software as input. Also can this button be used by the standby controller to react on an event when only standby supply is available (e.g. wakeup the TLF35584 via P33.10).

3.15 Debug System**3.15.1 OCDS1**

The OCDS1 signals are connected to the IDC16 plug (X401). They work with the port supply of Microcontroller (+5V default or +3,3V). For pinout of the connector see [Figure 6-11](#). You can connect any debugger to this connector. The signals /BRKIN and /BRKOUT are not connected per default. If you need these signals in the connector then assemble R424 and R425 or R426 with a 0R resistor.

If you connect a debug hardware make sure that the miniWiggler JDS (see ["miniWiggler JDS" on Page 3-4](#)) is not active (ACTIV LED is off) and on the DAP connector (X402) is no hardware connected or the hardware is tristated.

If the ACTIV LED is on, then stop the active DAS Server 'UDAS' and/or remove the USB connection to the PC.

In case that R217, R218 and R219 are assembled instead of R214, R215 and R216 then the connector can be used only for DAP connection to DAPE. If R214 up to R219 not assembled then the connector is not usable.

3.15.2 DAP

The board comes with a DAP connector (X402). For pinout of this connector see [Figure 6-12](#). You can connect a DAP hardware here. If you use this connector make sure that the miniWiggler JDS is not active (ACTIV LED is off) and a connected OCDS1 hardware is disconnected or tristated.

3.15.3 DAPE (only Emulation Device)

The board comes also with another DAP connector (X403) which is connected to DAPE in case that an emulation device is used. For pinout of this connector see [Figure 6-12](#). You can connect a DAP hardware here. If you use this connector make sure that the miniWiggler JDS is not active (ACTIV LED is off) and a connected OCDS1 hardware is disconnected or tristated in case that R217, R218 and R219 are assembled.

TriBoard Manual TC3X9

Hardware: TriBoard TC3X9 TH V1.0(1) and TriBoard TC3X9 V1.0

TriBoard Information

3.15.4 High speed with DAP/DAPE

For use the DAP connection with 160 MHz you need to remove 3 resistors to have a very short connection between device and connector. On the TC3X9 Triboard this 3 resistors are R214, R215 and R216 for DAP or R217, R218 and R219 for DAPE (red marked in [Figure 3-4](#) and [Figure 3-5](#)). This resistors needs to be removed.

Important: When the resistors are removed then only the DAP and DAPE connector on the board can be used. The on board wiggler and the OCDS1 connector couldn't be use (are disconnected) in this case, also the DAP/JTAG part of AGBT connector and the ETK connector couldn't be used.

All resistors are red marked in the following figures, on TriBoard TC3X9 V1.0 R217 is rotated by 90° and R215 is a little bit closer to R216.

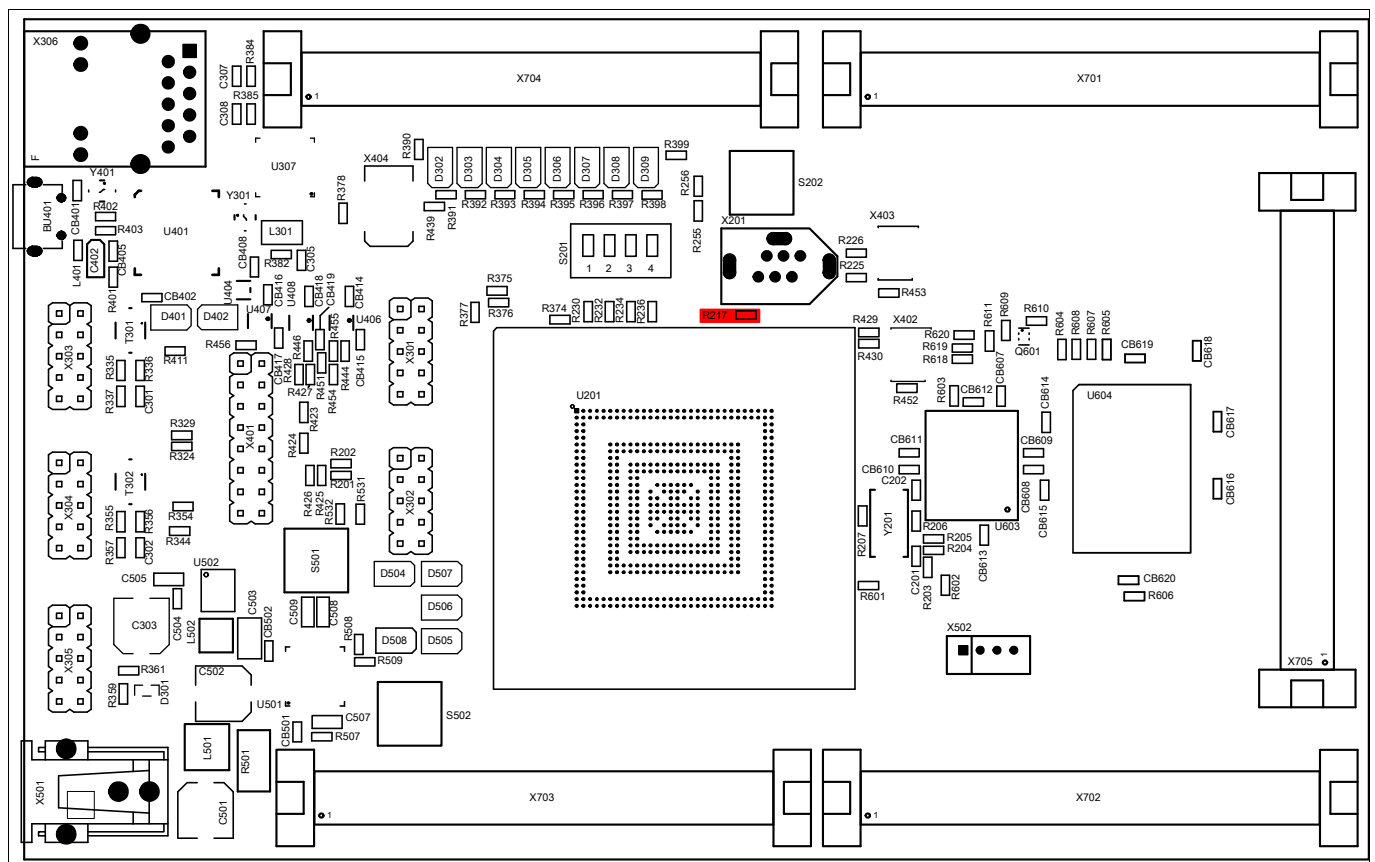

Figure 3-4 Location of DAP resistors on Top Side

TriBoard Information

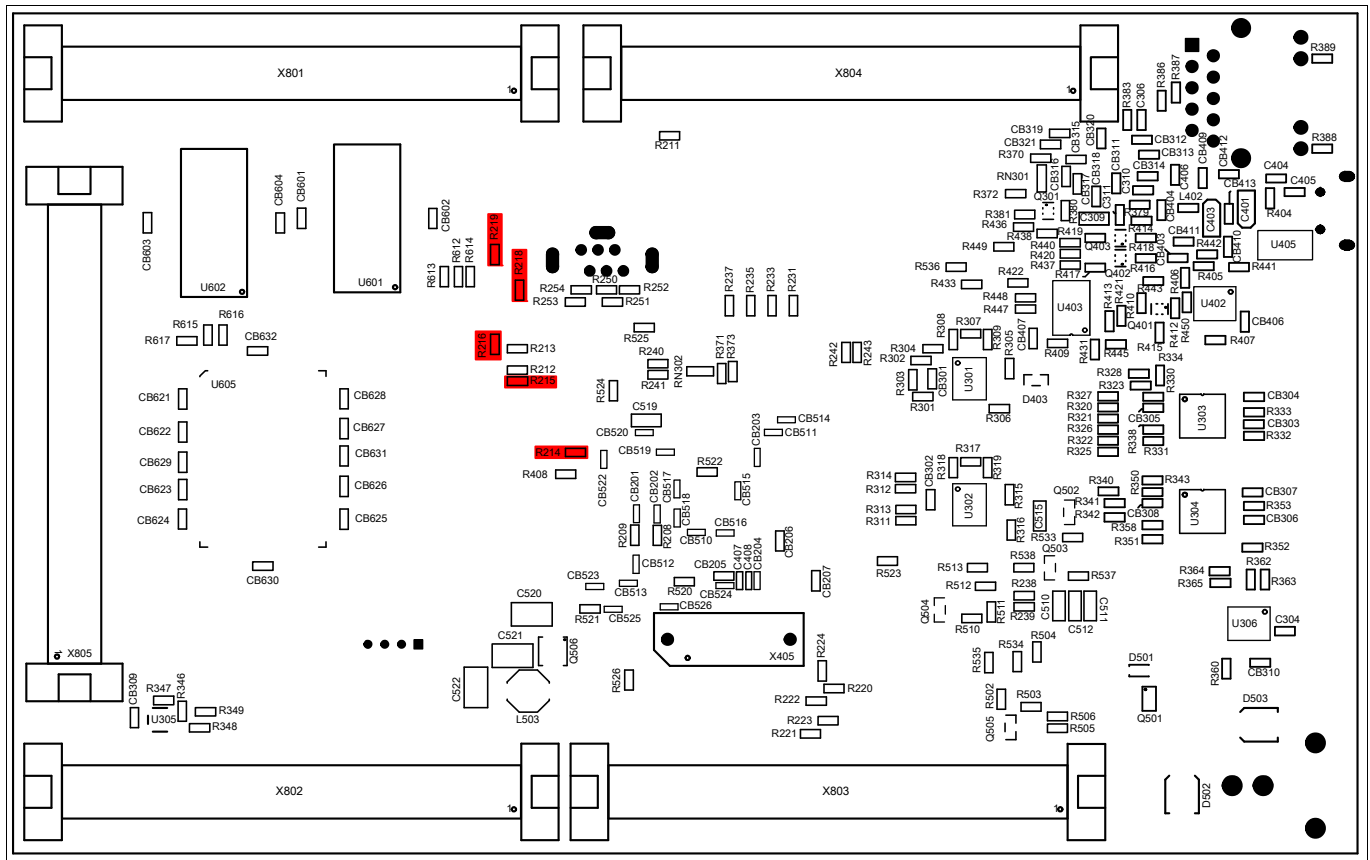

Figure 3-5 Location of DAP resistors on Bottom Side

3.15.5 AGBT (optional)

The TriBoard provide a 22 pin high speed samtec connector (X405) for highest speed connection via AGBT. This connector should be assembled by your self if needed.

The AGBT interface is only available on emulation devices.

For the pinout of connector see [Figure 6-15](#).

The needed Samtec connector is: ASP-137969-01 (serie ERM8, Nexus HS22).

3.15.6 ETK connector (optional)

The TriBoard provide a 10 pin samtec connector (X404) for connecting to an ETK. This connector should be assembled by your self if needed.

For the pinout of connector see [Figure 6-13](#).

The needed Samtec connector is: TFM-105-02-A.

3.15.7 EmW Power (optional)

The TriBoard provide the 4 pin power connector (X502) for the Ethernet miniWiggler (EmW). This connector should be assembled by your self if needed.

For the pinout of connector see [Figure 6-14](#).

The needed Samtec connector is the JST B4B-PH-K.

The connector provide the input voltage to the Ethernet miniWiggler and an enable/wakeup signal connected to TLF35584 and a standby voltage of +1,25V connected to VDDSB of device. In case the EmW is used you must

TriBoard Information

remove R522. If R522 is removed then you must make sure that the EmW is always connected. Otherwise with assembled R522 (default) you should not connect the pin 4 of connector.

The mentioned resistor is red marked in **Figure 3-6** and :

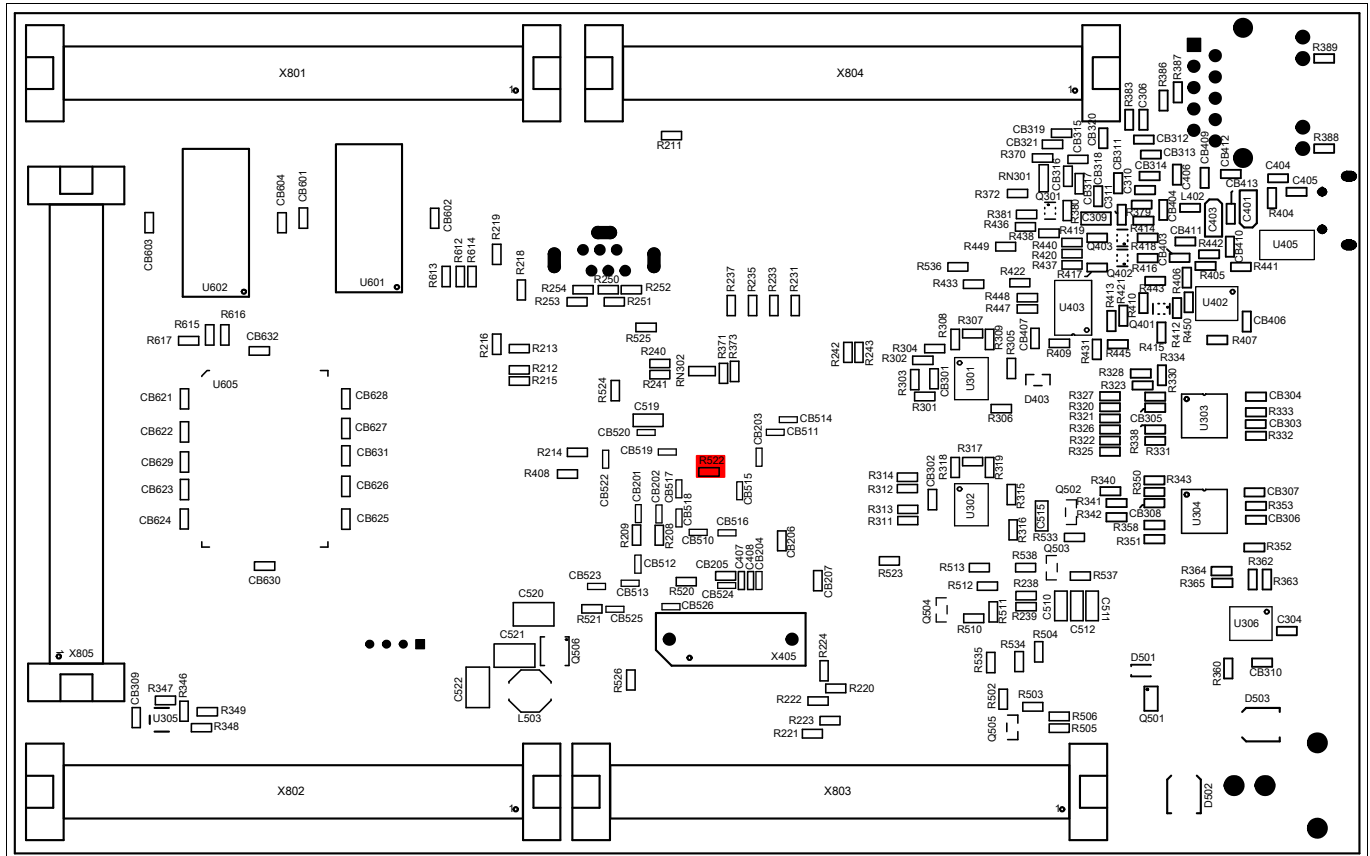

Figure 3-6 Resistor for VDDSB on TriBoard TC3X9 TH V1.0(1)

TriBoard Information

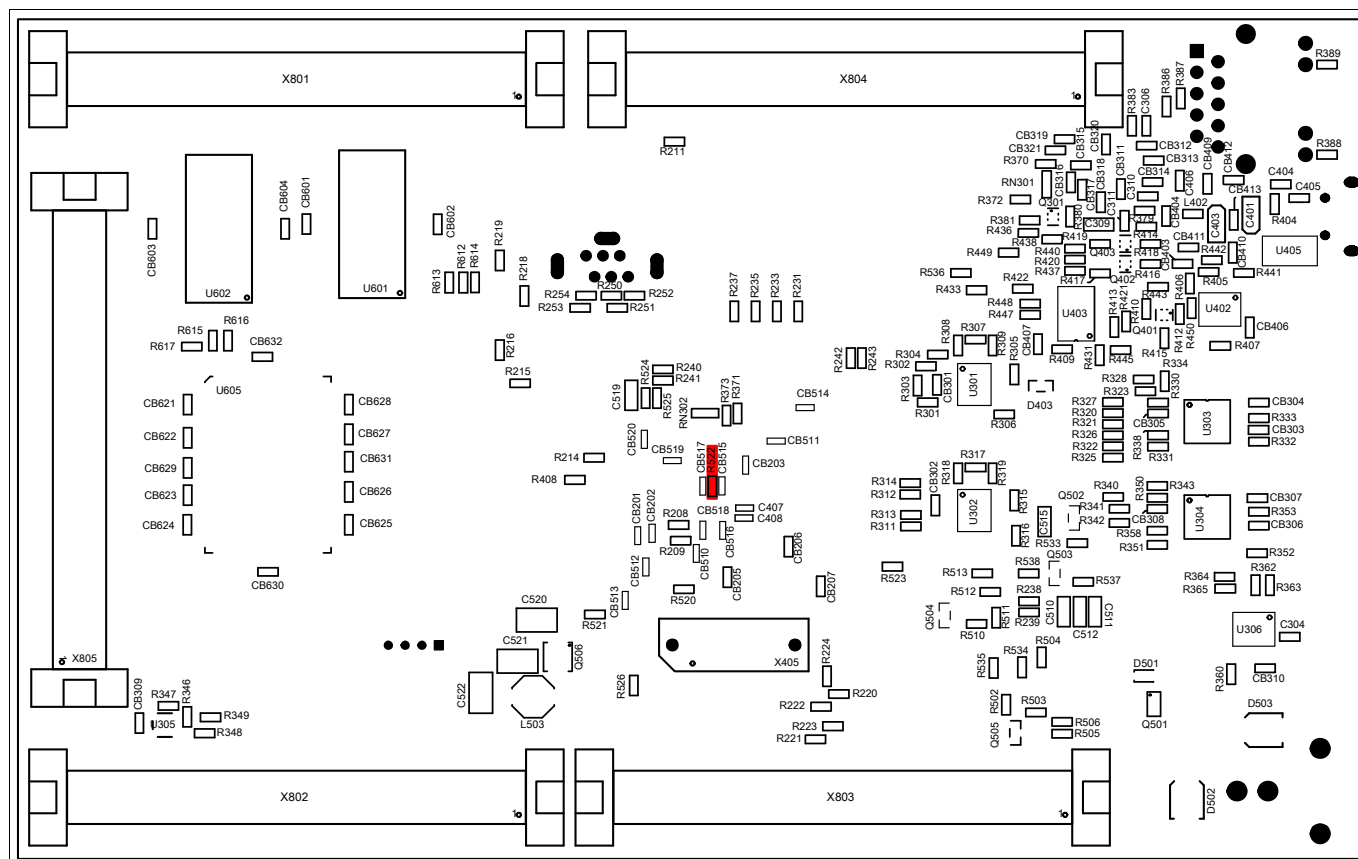

Figure 3-7 Resistor for VDDSB on TriBoard TC3X9 V1.0

TriBoard Configuration

4 TriBoard Configuration

4.1 HW Boot Configuration

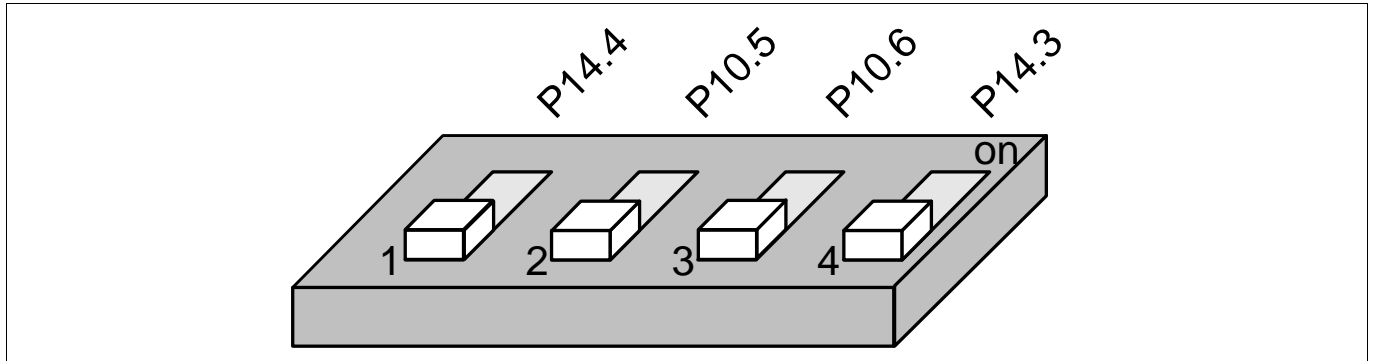

Figure 4-1 HW Configuration DIP-Switches

The picture above shows the definition of the boot HW configuration switch. The meaning of the switches will be described in the following table (Table 4-1).

Note: The ON position of the switch is equal to a logical LOW at the dedicated pin.

4.1.1 Default Pad State

P14.4 / HWCFG6 is used to select the Default Pad State. Dipswitch 1 used to select this.

In case that dipswitch1 is set to ON then all I/O pins are in tristate otherwise the internal pull-up devices are enabled on the I/O pins. Please note that after change Dipswitch 1 you must make a power cycle (switch off -> switch on) to use the new configuration.

In case that TriState is selected (Dipswitch 1 is set to ON) then the I/O pins are floating. If you need a specific level on different pins during startup (e.g. driver pins) then you must add the needed pull device (up or down). Some pins (especially the HWCFG pins) haven always the needed external pull-up and/or pull-down resistor assembled on the board.

4.1.2 Bootmode

Table 4-1 User Startup Modes ¹⁾²⁾³⁾

HWCFG[5...3]	Type of Boot	2	3	4
XX1	Start-up mode is selected by Boot Mode Index	X	X	OFF
110	Internal Start from Flash	OFF	OFF	ON
100	Alternate Boot Mode, Generic Bootstrap Loader on fail (P14.0/P14.1)	ON	OFF	ON
010	Alternate Boot Mode, ASC Bootstrap Loader on fail (P15.2/P15.3)	OFF	ON	ON
000	Generic Bootstrap Loader (P14.0/P14.1)	ON	ON	ON

1) The shadowed line indicates the default setting.

2) 'x' represents the don't care state.

3) 2 to 4 are the Dip Switch numbers.

TriBoard Configuration

4.2 Assembly Options

4.2.1 General optional resistors

Table 4-2 General optional resistors (default assembly in brackets)

Component	Description
R202	Connect P20.2 (/TESTMODE) to GND (not assembled)
R203	XTAL1 Rload (50 Ohm) (not assembled)
R206	XTAL Rparallel (not assembled)
R207	XTAL2 Rserial (assembled)
R238	Switch off EVRC (not assembled)
R240	Switch off EVR33 (not assembled)
R390	Connect V_STBY to toggle LEDs D302...D305 (assembled)
R399	Connect V_UC to toggle LEDs D306...D309 (assembled)
R423	Connect P20.0 with miniWiggler JDS (not assembled)
R424	Connect P20.0 with OCDS1 connector (not assembled)
R425	Connect P20.1 with OCDS1 connector (not assembled)
R426	Connect P20.2 with OCDS1 connector (not assembled)
R427	Connect P20.1 with USR1 of miniWiggler JDS (not assembled)
R428	Connect P20.2 with USR1 of miniWiggler JDS (not assembled)
R429	Connect P21.6 (DAP3) with USR1 of DAP (assembled)
R430	Connect P20.2 with USR1 of DAP (not assembled)
R433	Connect P20.1 with ETK connector (not assembled)
R439	Connect P21.7 with ETK connector (not assembled)
R508	Connect pin MPS of TLF35584 to V_CO (not assembled)
R509	Connect pin MPS of TLF35584 to Ground (assembled)
R524	Connect VDDP3 to V_UC (not assembled)
R525	Connect VDDP3 to +3V3 (not assembled)

Note: All resistors are red marked in the following figures, on TriBoard TC3X9 V1.0 R203 and R525 are rotated by 90° also R524 and R525 are slicely shifted (see also [Figure 7-12](#)).

TriBoard Configuration

4.2.2 Resistors for peripherals

Table 4-3 Resistors for peripherals (default assembly in brackets)

Component	Description
R220	Connect V_VR with VDDM (assembled)
R221	Connect +3V3 with VDDM (not assembled)
R222	Connect VAREF1 with VDDM (assembled)
R223	Connect VAREF2 with VDDM (assembled)
R224	Connect VAREF3 with VDDM (assembled)
R301	Connect P20.7 with RXD of CAN0 transceiver (assembled)
R302	Connect P20.8 with TXD of CAN0 transceiver (assembled)
R303	Connect P14.1 with RXD of CAN0 transceiver (not assembled)
R304	Connect P14.0 with TXD of CAN0 transceiver (not assembled)
R311	Connect P23.0 with RXD of CAN1 transceiver (assembled)
R312	Connect P23.1 with TXD of CAN1 transceiver (assembled)
R313	Connect P00.1 with RXD of CAN1 transceiver (not assembled)
R314	Connect P00.0 with TXD of CAN1 transceiver (not assembled)
R320	Connect P14.10 with TXD of ERAY-A transceiver (assembled)
R321	Connect P14.9 with TXDEN of ERAY-A transceiver (assembled)
R322	Connect P14.8 with RXD of ERAY-A transceiver (assembled)
R323	Connect P32.3 with EN of ERAY-A transceiver (assembled)
R324	Connect P32.2 with ERRN of ERAY-A transceiver (assembled)
R325	Connect P02.1 with RXD of ERAY-A transceiver (not assembled)
R326	Connect P02.4 with TXDEN of ERAY-A transceiver (not assembled)
R327	Connect P02.0 with TXD of ERAY-A transceiver (not assembled)
R328	Connect P10.2 with EN of ERAY-A transceiver (not assembled)
R329	Connect P10.1 with ERRN of ERAY-A transceiver (not assembled)
R340	Connect P14.5 with TXD of ERAY-B transceiver (assembled)
R341	Connect P14.6 with TXDEN of ERAY-B transceiver (assembled)
R342	Connect P14.7 with RXD of ERAY-B transceiver (assembled)
R343	Connect P20.10 with EN of ERAY-B transceiver (assembled)
R344	Connect P20.9 with ERRN of ERAY-B transceiver (assembled)
R348	Connect P15.4 with SCL of I2C Eeprom (assembled)
R349	Connect P15.5 with SDA of I2C Eeprom (assembled)
R364	Connect P15.1 with RXD of LIN1 transceiver (assembled)
R365	Connect P15.0 with TXD of LIN1 transceiver (assembled)
R370	Connect P11.12 with RX_CLK of Ethernet PHY (assembled)
R371	Connect P11.12 with REF_CLK of Ethernet PHY (assembled)
R372	Connect P11.11 with CRS_DV of Ethernet PHY (assembled)
R373	Connect P11.5 with TX_CLK of Ethernet PHY (assembled)

TriBoard Configuration

Table 4-3 Resistors for peripherals (default assembly in brackets) (continued)

Component	Description
R374	Connect P11.6 with TX_EN of Ethernet PHY (assembled)
R375	Connect P12.1 with MDIO of Ethernet PHY (assembled)
R376	Connect P12.0 with MDC of Ethernet PHY (assembled)
R377	Connect P15.8 with MDINT of Ethernet PHY (not assembled)
RN301	Connect P11.7...10 with RDX3...0 of Ethernet PHY (assembled)
RN302	Connect P11.0...3 with TDX3...0 of Ethernet PHY (assembled)
R436	Connect P14.0 with RXD of USB to UART (assembled)
R437	Connect P14.1 with TXD of USB to UART (assembled)
R438	Connect P15.2 with RXD of USB to UART (not assembled)
R440	Connect P15.3 with TXD of USB to UART (not assembled)

Note: All resistors are red marked in the following figures

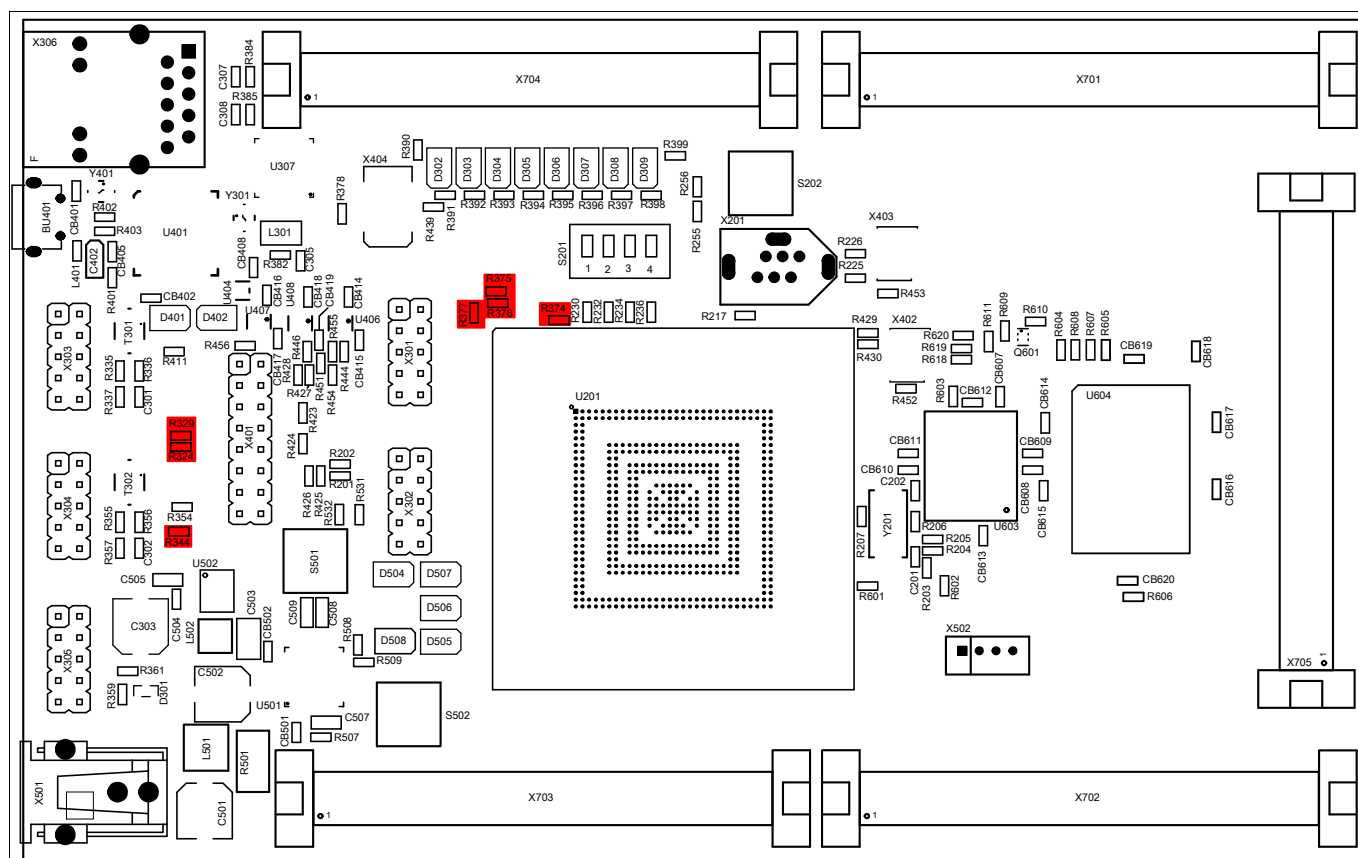

Figure 4-4 Location of peripheral resistors on Top Side

TriBoard Configuration

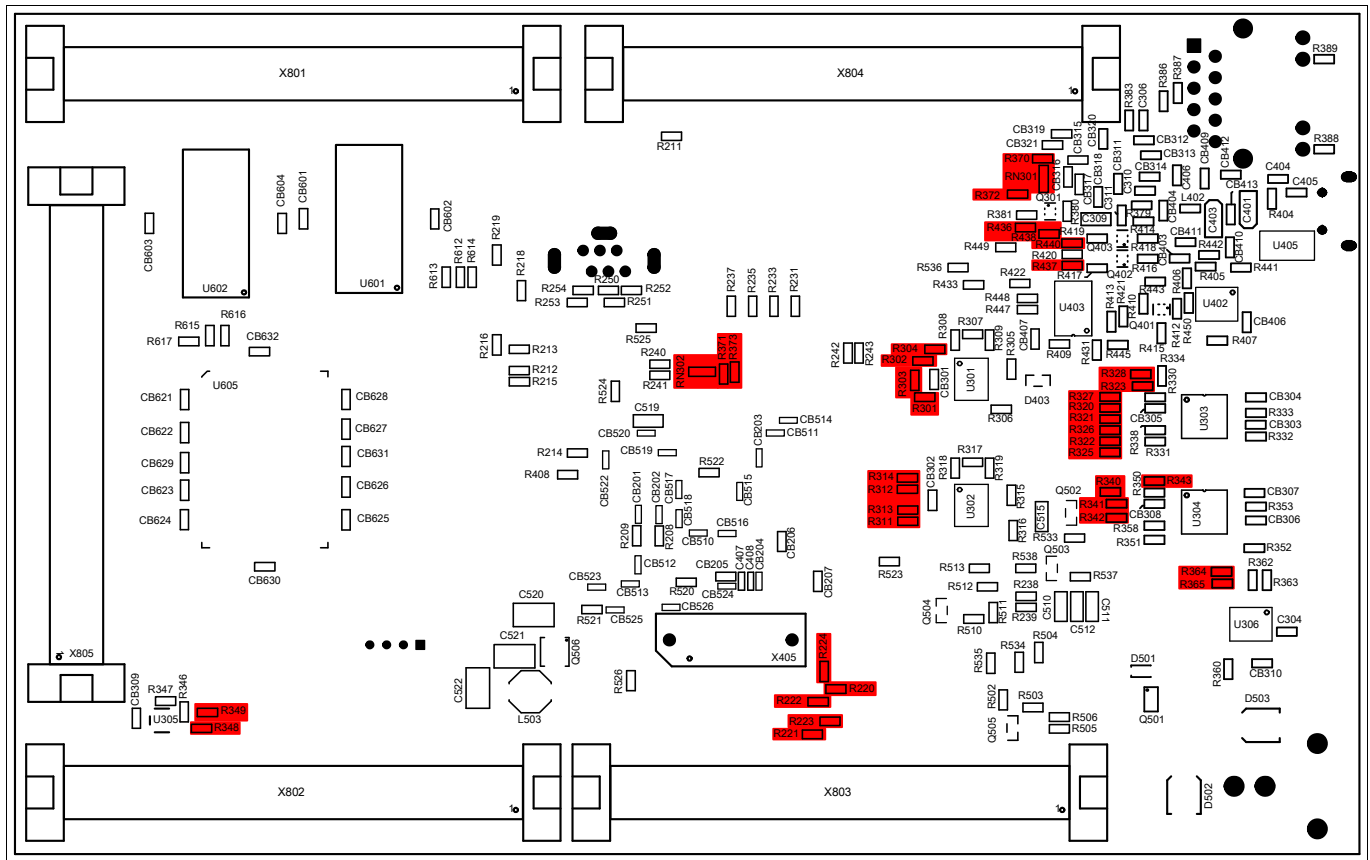

Figure 4-5 Location of peripheral resistors on Bottom Side

4.2.3 Resistors for memories

Table 4-4 Resistors for memories (default assembly in brackets)

Component	Description
R612	Connect /CS1 to 16-bit SRAMs (assembled)
R613	Connect /CS0 to 16-bit SRAMs (not assembled)
R615	Connect /CS1 to 32-bit SRAM (not assembled)
R616	Connect /CS0 to 32-bit SRAM (not assembled)
R618	Connect /CS1 to 32-bit Flash (not assembled)
R619	Connect /CS0 to 32-bit Flash (assembled)

Note: All resistors are red marked in the following figures

TriBoard Configuration

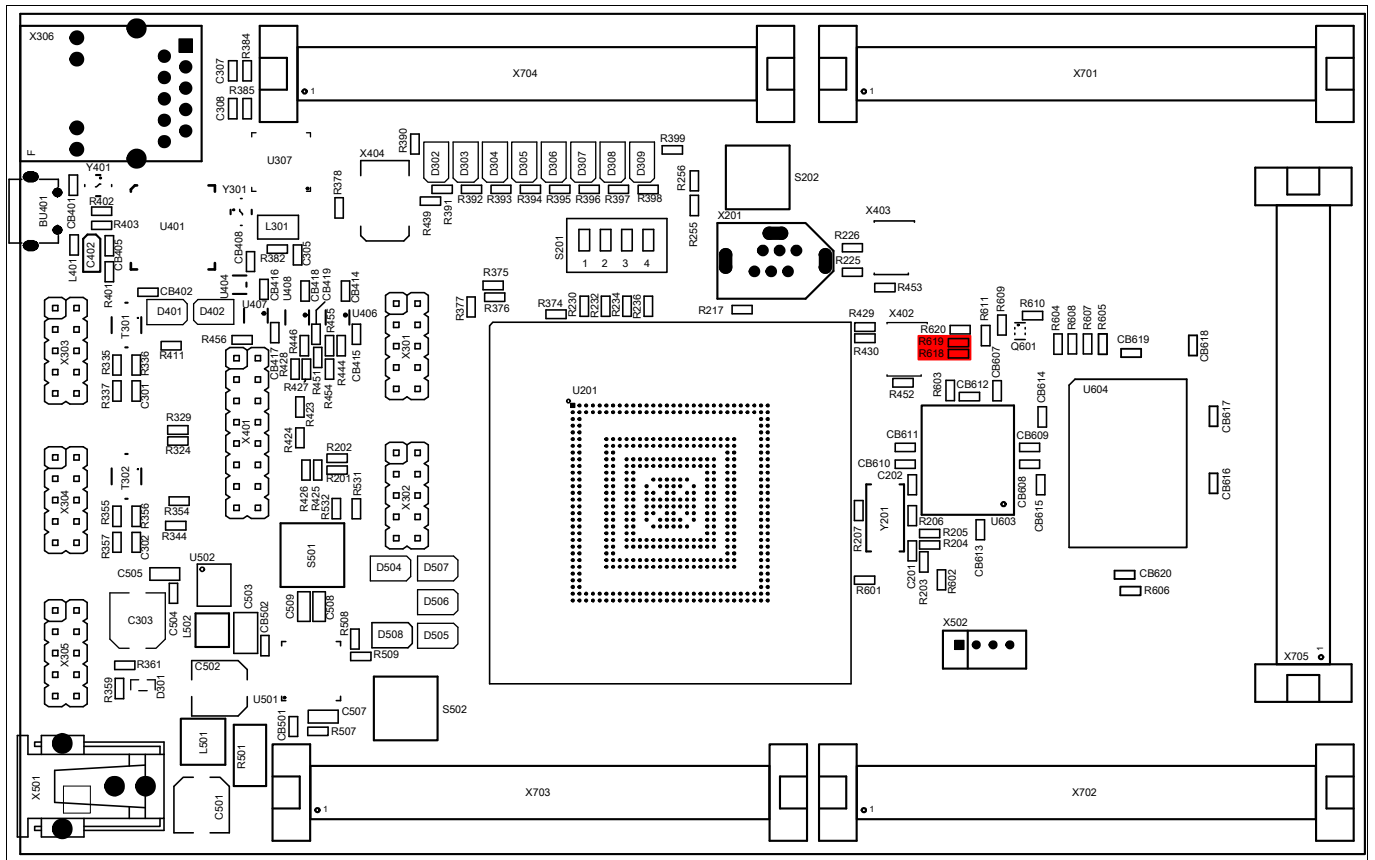

Figure 4-6 Location of memories resistors on Top Side

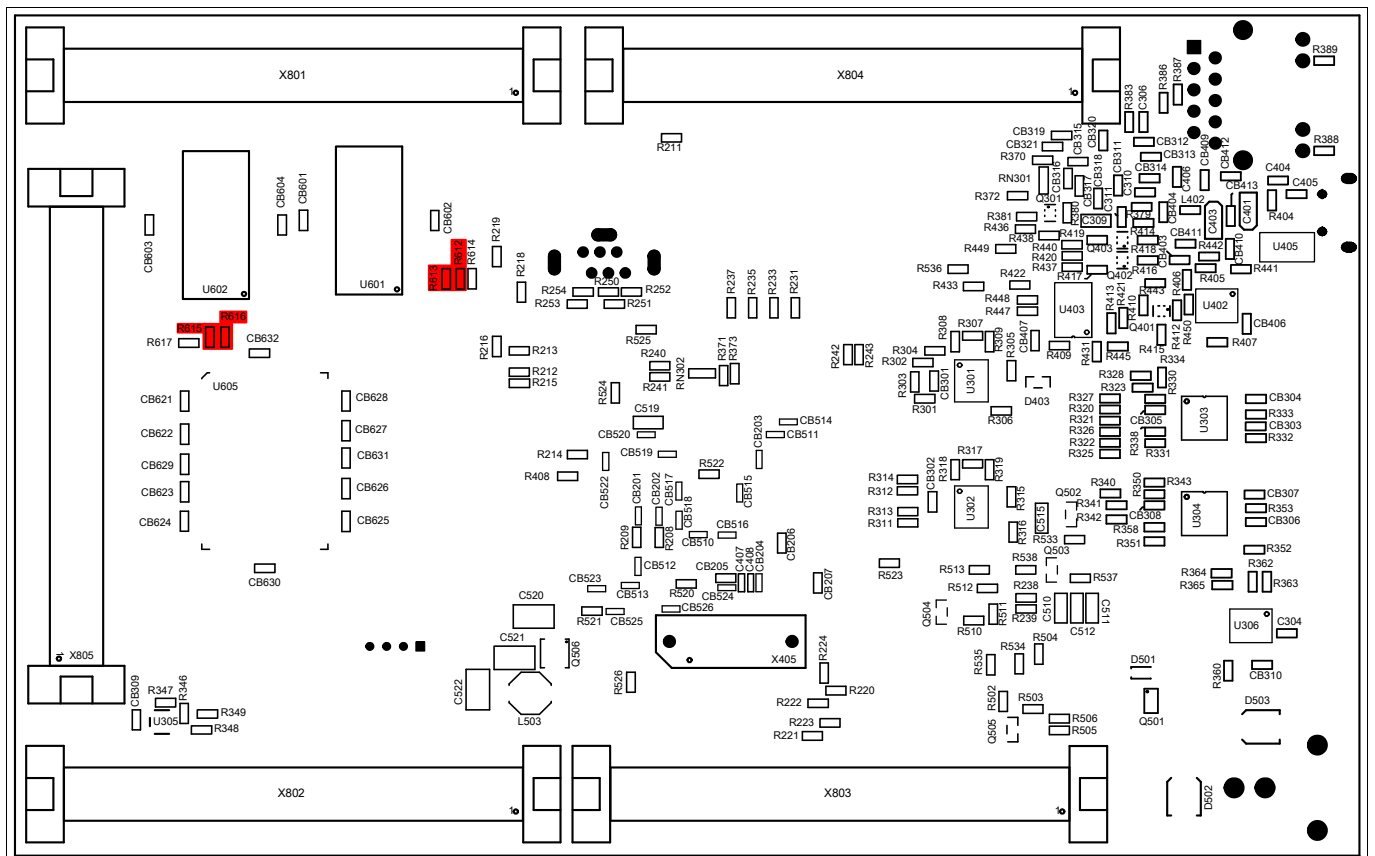

Figure 4-7 Location of memories resistors on Bottom Side

Signal (on board used) Description

5 Signal (on board used) Description

For more information about the signals please see the user manual/datasheet for TC3X9 and/or the schematics of the board.

All not mentioned signals are not used on the board and can be used outside. Optional marked signals are used only if they are connected (default is that they are not used on the board).

5.1 Power Signals

Table 5-1 Power Signals

Short name	Description
VCC_IN	Supply Input (3,5V...40V)
VIN	Input Voltage of Power Supply Device
GND	Ground
V_PREPEG	Pre Regulator Voltage (~5,8V)
V_UC	Microcontroller Supply Voltage (5V or 3,3V depends on assembled TLF35584)
V_CO	Communication Supply Voltage (5V)
V_VR	Reference Supply Voltage (5V)
V_STBY	Standby Supply Voltage (5V or 3,3V depends on assembled TLF35584)
VDD	Core Supply Voltage (1,25V)
VDDSB	Emulation Stand-by SRAM Supply Voltage (1,25V)
VDDP3	Flash Power Supply Voltage (3,3V)
VFLEX	Flexport Supply Voltage (3,3V)
VEBU	EBU Supply Voltage (3,3V)
VEXTOSC	Oscillator Port Supply Voltage (5V or 3,3V depends on assembled TLF35584)
VDDOSC	Oscillator Core Supply Voltage (1,25V)
VSSOSC	Oscillator Ground
VDDM	ADC Analog Part Supply Voltage (5V or 3,3V selectable via 0R resistors)
VAREF1	ADC Reference Voltage 1 (VDDM)
VAREF2	ADC Reference Voltage 2 (VDDM)
VAREF3	ADC Reference Voltage 3 (VDDM)
VDD_USB	Supply Voltage from USB (5V)
VDD_FT	Supply Voltage FT2232HL device (3,3V)

5.2 Reset Signals

Table 5-2 Reset Signals

Short name	Description
/PORST	Power On Reset
/DBG_PORST	Power On Reset from debug connectors
/ESR0	External Service Request 0 (Hardware Reset)
/ESR1	External Service Request 1 (Non Maskable Interrupt)

Signal (on board used) Description

5.3 Config Signals

Table 5-3 Config Signals

Short name	Description
P14.5	HWCFG1 (EVR33OFF / EVR33ON)
P14.2	HWCFG2 (EVRCOFF / EVRCON)
P14.4	HWCFG6 (Pins in tristate / Pins with pull-up)
P14.3	HWCFG3 (Boot from pins / Boot from Flash BMI)
P10.5	HWCFG4 (see boot configuration Table 4-1)
P10.6	HWCFG5 (see boot configuration Table 4-1)

5.4 Clock Signals

Table 5-4 Clock Signals

Short name	Description
XTAL1	Crystal Oscillator Input
XTAL2	Crystal Oscillator Output

5.5 Debug Signals

Table 5-5 Debug Signals

Short name	Description
/TRST	Test Reset
DAP0	Device Access Port Line 0 / Test Data Clock (TCK)
DAP1	Device Access Port Line 1 / Test Data Select (TMS)
DAP2	Device Access Port Line 2 / Test Data Output (TDO)
DAPE0	Device Access Port Line 0 (Emulation part)
DAPE1	Device Access Port Line 1 (Emulation part)
DAPE2	Device Access Port Line 2 (Emulation part)
P21.6	Test Data Input (TDI)
DAP0_A	DAP0 / DAPE0 / TCK from debug connectors
DAP1_A	DAP1 / DAPE1 / TMS from debug connectors
P21.7	DAP2 / DAPE2 / TDO from debug connectors
P20.2	Test Mode Select Input
P20.1	TriCore Breakpoint Input
P20.0	TriCore Breakpoint Output
AGBT_CLK_P/_N	AGBT Clock Input
AGBT_TX0_P/_N	AGBT Transmit Output
AGBT_ERR	AGBT Error Output

Signal (on board used) Description

5.6 Peripheral Signals

Table 5-6 Peripheral Signals

Short name	Description
P14.1	ASCLIN0 Receive Input A CAN01 Receive Input B (optional)
P14.0	ASCLIN0 Transmit Output CAN01 Transmit Output (optional)
P15.3	ASCLIN0 Receive Input B (optional)
P15.2	ASCLIN0 Transmit Output (optional)
P15.1	ASCLIN1 Receive Input A
P15.0	ASCLIN1 Transmit Output
P15.4	I2C0 Serial Clock
P15.5	I2C0 Serial Data Input C und Output
P20.7	CAN00 Receive Input B
P20.8	CAN00 Transmit Output
P23.0	CAN10 Receive Input C
P23.1	CAN10 Transmit Output
P00.1	CAN10 Receive Input A (optional)
P00.0	CAN10 Transmit Output (optional)
P14.10	E-Ray Channel A Transmit Data Output
P14.9	E-Ray Channel A Transmit Data Output enable
P14.8	E-Ray Channel A Receive Data Input 0
P32.3	E-Ray Channel A Enable Output
P32.2	E-Ray Channel A Error Input
P14.5	E-Ray Channel B Transmit Data Output
P14.6	E-Ray Channel B Transmit Data Output enable
P14.7	E-Ray Channel B Receive Data Input 0
P20.10	E-Ray Channel B Enable Output
P20.9	E-Ray Channel B Error Input
P02.0	E-Ray Channel A Transmit Data Output (optional)
P02.4	E-Ray Channel A Transmit Data Output enable (optional)
P02.1	E-Ray Channel A Receive Data Input 2 (optional)
P10.2	E-Ray Channel A Enable Output (optional)
P10.1	E-Ray Channel A Error Input (optional)
P11.0	Ethernet TXD3 Output
P11.1	Ethernet TXD2 Output
P11.2	Ethernet TXD1 Output
P11.3	Ethernet TXD0 Output
P11.5	Ethernet TXCLK Output

Signal (on board used) Description

Table 5-6 Peripheral Signals (continued)

Short name	Description
P11.6	Ethernet TXEN Output
P11.7	Ethernet RXD3 Input A
P11.8	Ethernet RXD2 Input A
P11.9	Ethernet RXD1 Input A
P11.10	Ethernet RXD0 Input A
P11.11	Ethernet CRSDV Input A
P11.12	Ethernet RXCLK / REFCLK Input A
P12.0	Ethernet Management Data Clock Output (MDC)
P12.1	Ethernet Management Data Input/Output (MDIO)
P15.8	Ethernet MD Interrupt Input (optional)
P14.2	QSPI2 Slave Select Output 1 for SCS of TLF35584
P15.3	QSPI2 Master Clock Output for SCL of TLF35584
P15.6	QSPI2 Master Transmit Output for SDI of TLF35584
P15.7	QSPI2 Master Receive Input B for SDO from TLF35584
P14.3	Output for Watchdog Input of TLF35584
P33.8	SMU_FSP0 Output for Error Signal Input of TLF35584
P33.9	Input for Safe State Signal 1 from TLF35584
P33.10	Output for Wake/Inhibit Input of TLF35584
P20.0	HSCT System Clock
P21.2	HSCT Data Negative Input
P21.3	HSCT Data Positive Input
P21.4	HSCT Data Negative Output
P21.5	HSCT Data Positive Output
P20[11...14]	On board LED's
P33[4...7]	On board LED's (standby voltage supplied)

5.7 EBU Signals

Table 5-7 EBU Signals

Short name	Description
AD0 / P30.9	Address Data Line 0 Input/Output
AD1 / P30.14	Address Data Line 1 Input/Output
AD2 / P30.13	Address Data Line 2 Input/Output
AD3 / P30.8	Address Data Line 3 Input/Output
AD4 / P30.6	Address Data Line 4 Input/Output
AD5 / P30.10	Address Data Line 5 Input/Output
AD6 / P30.15	Address Data Line 6 Input/Output
AD7 / P30.7	Address Data Line 7 Input/Output

Signal (on board used) Description

Table 5-7 EBU Signals (continued)

Short name	Description
AD8 / P30.4	Address Data Line 8 Input/Output
AD9 / P30.12	Address Data Line 9 Input/Output
AD10 / P30.11	Address Data Line 10 Input/Output
AD11 / P30.1	Address Data Line 11 Input/Output
A12 / P30.2	Address Data Line 12 Input/Output
AD13 / P30.5	Address Data Line 13 Input/Output
AD14 / P30.0	Address Data Line 14 Input/Output
AD15 / P30.3	Address Data Line 15 Input/Output
AD16 / P31.7	Address Data Line 16 Input/Output
AD17 / P31.15	Address Data Line 17 Input/Output
AD18 / P31.14	Address Data Line 18 Input/Output
AD19 / P31.12	Address Data Line 19 Input/Output
AD20 / P31.6	Address Data Line 20 Input/Output
AD21 / P31.10	Address Data Line 21 Input/Output
AD22 / P31.13	Address Data Line 22 Input/Output
AD23 / P31.5	Address Data Line 23 Input/Output
AD24 / P31.4	Address Data Line 24 Input/Output
AD25 / P31.11	Address Data Line 25 Input/Output
AD26 / P31.3	Address Data Line 26 Input/Output
AD27 / P31.9	Address Data Line 27 Input/Output
AD28 / P31.2	Address Data Line 28 Input/Output
AD29 / P31.1	Address Data Line 29 Input/Output
AD30 / P31.0	Address Data Line 30 Input/Output
AD31 / P31.8	Address Data Line 31 Input/Output
A0 / P24.14	Address Line 0 Output
A1 / P24.13	Address Line 1 Output
A2 / P24.11	Address Line 2 Output
A3 / P24.14	Address Line 3 Output
A4 / P24.10	Address Line 4 Output
A5 / P24.6	Address Line 5 Output
A6 / P24.9	Address Line 6 Output
A7 / P24.15	Address Line 7 Output
A8 / P24.7	Address Line 8 Output
A9 / P24.4	Address Line 9 Output
A10 / P24.8	Address Line 10 Output
A11 / P24.0	Address Line 11 Output
A12 / P24.5	Address Line 12 Output
A13 / P24.3	Address Line 13 Output

Signal (on board used) Description

Table 5-7 EBU Signals (continued)

Short name	Description
A14 / P24.2	Address Line 14 Output
A15 / P24.1	Address Line 15 Output
A16 / P25.15	Address Line 16 Output
A17 / P25.13	Address Line 17 Output
A18 / P25.14	Address Line 18 Output
A19 / P25.12	Address Line 19 Output
/CS0 / P25.5	Chip Select 0 Output
/CS1 / P25.4	Chip Select 1 Output
BAABA0_/CS2 / P25.3	Advance Burst Address / Chip Select 2 Output
BC0 / P25.8	Byte Control Line 0 Output
BC1 / P25.9	Byte Control Line 1 Output
BC2 / P25.10	Byte Control Line 2 Output
BC3 / P25.11	Byte Control Line 3 Output
/ADV / P25.7	Address Valid Strobe Output
/RD / P25.1	Read Control Output
/WR / P25.2	Write Control Output
/WAIT / P25.6	Wait / Terminate Burst Control Input
BFCLKO / P25.0	Burst Clock Output
BFCLKI / P26.0	Burst Clock Feedback Input

Connector Pin Assignment

6 Connector Pin Assignment

The TriBoard will be shipped with five male (plug) connectors on top layer and five female (socket) connectors on bottom layer. The default connectors are 80-pol. Board to Board connectors from Samtec:

<http://www.samtec.com>

Plug:

FTSH-140-02-L-DV-ES-A

Socket:

FLE-140-01-G-DV-A

6.1 On Board only used signals

Following port pins are only used on board and are not connected to any connector also not via resistor:

Table 6-1 On Board only used Signals

Short name	Description
P32.0	Used as VGATE1N for EVRC
P32.1	Used as VGATE1P for EVRC
P14.2	Used as HWCFG2 and Slave Select Output (SLSO21) to TLF35584
P14.4	Used as HWCFG6 and Output to Watchdog Input of TLF35584
P14.5	Used as HWCFG1 and E-Ray Channel B Transmit Data Output
P14.6	Used as E-Ray Channel B Transmit Data Output enable

Connector Pin Assignment

6.2 TC3X9 Connector / Top View

BUS EXPANSION (X701,X801)			PERIPHERALS (X702,X802)			
GND	1	2	GND	1	2	GND
GND	3	4	GND	3	4	GND
P30.9	5	6	P21.6	5	6	VCC_IN
P30.14	7	8	P21.7	7	8	VCC_IN
P30.13	9	10	P24.14	9	10	P22.8
P30.8	11	12	P24.12	11	12	P22.9
P30.6	13	14	P24.13	13	14	P22.10
P30.10	15	16	P24.11	15	16	/ESR0
P30.15	17	18	P24.10	17	18	P22.11
P30.7	19	20	P24.6	19	20	GND
P30.4	21	22	P24.9	21	22	/PORST
P30.12	23	24	P24.15	23	24	P23.3
P30.11	25	26	P24.7	25	26	P23.4
P30.1	27	28	P24.4	27	28	P23.1
P30.2	29	30	P24.8	29	30	P22.1
P30.5	31	32	P24.0	31	32	P22.0
P30.0	33	34	P24.5	33	34	P22.3
P30.3	35	36	P24.3	35	36	P22.2
P31.7	37	38	P24.2	37	38	P20.10
P31.15	39	40	P24.1	39	40	P00.4
P31.14	41	42	P25.15	41	42	P20.6
P31.12	43	44	P25.13	43	44	P20.2
P31.6	45	46	P25.14	45	46	P00.3
P31.10	47	48	P25.12	47	48	P00.2
P31.13	49	50	P21.2	49	50	GND
P31.5	51	52	P21.3	51	52	P32.4
P31.4	53	54	P21.4	53	54	
P31.11	55	56	P21.5	55	56	P15.5
P31.3	57	58	P25.3	57	58	P15.4
P31.9	59	60	P25.4	59	60	P15.1
P31.2	61	62	P25.5	61	62	P15.0
P31.1	63	64	P25.11	63	64	P00.12
P31.0	65	66	P25.10	65	66	P00.11
P31.8	67	68	P25.9	67	68	P00.5
P25.1	69	70	P25.8	69	70	P20.8
P25.2	71	72	P20.0	71	72	P10.8
	73	74	P25.7	73	74	P10.3
	75	76	P25.6	75	76	GND
P26.0	77	78	P25.0	77	78	+3V3
P21.0	79	80	P21.1	79	80	+3V3

Figure 6-1 Connector for TC3X9 - Pinout (Part I, Top View)

Connector Pin Assignment

ADC (X703, X803)			GTM / PORTS (X704, X804)			
GND	1	2	GND	1	2	GND
GND	3	4	GND	3	4	GND
AN0	5	6	AN16	5	6	P11.14
AN1	7	8	AN17	7	8	P11.15
AN2	9	10	AN18	9	10	P14.11
AN3	11	12	AN19	11	12	P14.12
AN4	13	14	AN20	13	14	P14.13
AN5	15	16	AN21	15	16	P14.14
AN6	17	18	AN22	17	18	P14.7
AN7	19	20	AN23	19	20	P14.8
AN8	21	22	AN24	21	22	P14.9
AN9	23	24	AN25	23	24	P14.10
AN10	25	26	AN26	25	26	P15.6
AN11	27	28	AN27	27	28	P15.7
AN12	29	30	AN28	29	30	P20.1
AN13	31	32	AN29	31	32	P01.5
AN14	33	34	AN30	33	34	P01.6
AN15	35	36	AN31	35	36	P23.0
GND	37	38	GND	37	38	P23.2
VDDM	39	40	VAREF1	39	40	P23.5
GND	41	42	VAREF2	41	42	P23.6
GND	43	44	GND	43	44	P23.7
AN32	45	46	AN40	45	46	P13.10
AN33	47	48	AN41	47	48	P13.11
AN34	49	50	AN42	49	50	P32.2
AN35	51	52	AN43	51	52	P32.3
AN36	53	54	AN44	53	54	P32.5
AN37	55	56	AN45	55	56	P33.8
AN38	57	58	AN46	57	58	P33.9
AN39	59	60	AN47	59	60	P33.10
GND	61	62	GND	61	62	P33.13
P33.3	63	64	P33.6	63	64	P33.14
P33.2	65	66	P33.0	65	66	P33.15
P33.1	67	68	P33.4	67	68	P32.6
VEXT	69	70	+3V3	69	70	P32.7
P02.6	71	72	P00.6	71	72	P34.4
P02.7	73	74	P00.7	73	74	P34.5
P02.8	75	76	P00.8	75	76	P01.7
P33.7	77	78	P14.3	77	78	+3V3
P33.11	79	80	P33.12	79	80	+3V3

Figure 6-2 Connector for TC3X9 - Pinout (Part II, Top View)

Connector Pin Assignment

ADC2 (X705, X805)			
GND	1	2	GND
GND	3	4	GND
AN48	5	6	AN64
AN49	7	8	AN65
AN50	9	10	AN66
AN51	11	12	AN67
AN52	13	14	AN68
AN53	15	16	AN69
AN54	17	18	AN70
AN55	19	20	AN71
AN56	21	22	AN72
AN57	23	24	AN73
AN58	25	26	GND
AN59	27	28	P10.9
AN60	29	30	P10.10
AN61	31	32	P10.11
AN62	33	34	P10.13
AN63	35	36	P10.14
GND	37	38	GND
P02.12	39	40	VAREF3
P02.13	41	42	P10.15
GND	43	44	GND
P02.14	45	46	P01.8
P15.10	47	48	P01.9
P15.11	49	50	P01.10
P15.12	51	52	P01.11
P15.13	53	54	P01.12
P15.14	55	56	P01.13
P15.15	57	58	P01.14
P02.15	59	60	P01.15
GND	61	62	GND
P01.0	63	64	P00.13
P01.1	65	66	P00.14
P01.2	67	68	P00.15
VEXT	69	70	+3V3
P13.4	71	72	P13.12
P13.5	73	74	P13.13
P13.6	75	76	P13.14
P13.7	77	78	P13.15
P13.9	79	80	P14.15

Figure 6-3 Connector for TC3X9 - Pinout (Part III, Top View)

Connector Pin Assignment

6.3 Power connector pinout

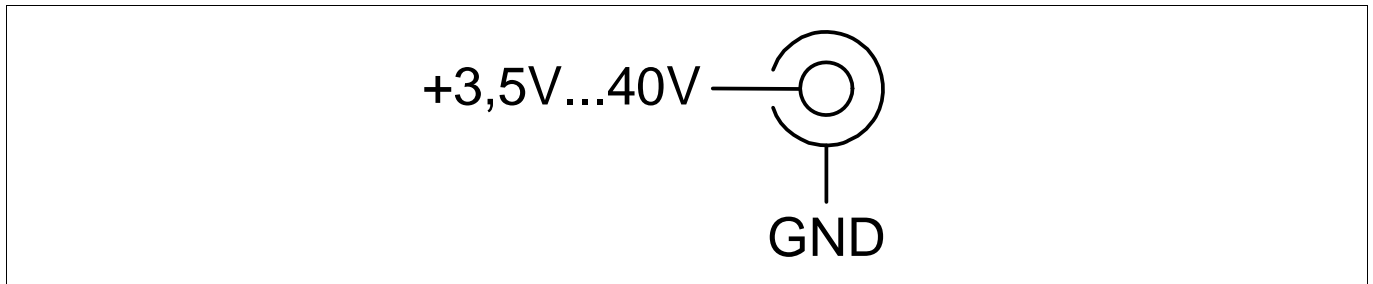

Figure 6-4 Power connector pinout (Roka 520 2550)

6.4 USB connector pinout

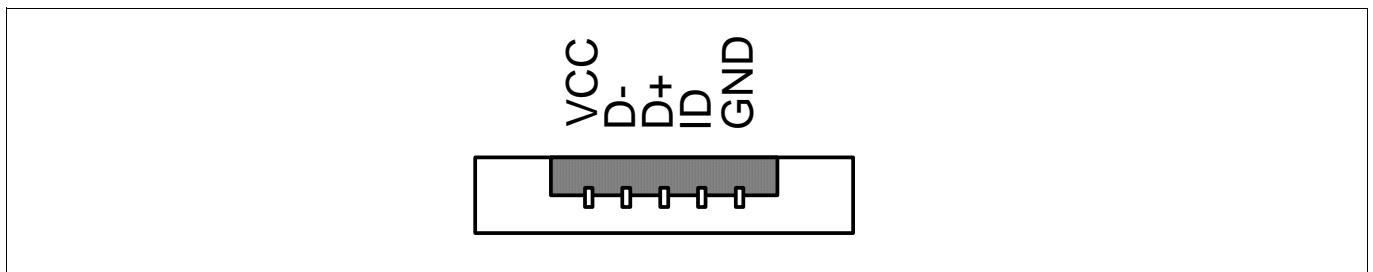

Figure 6-5 USB connector pinout (Micro USB B-type)

6.5 FlexRay™ (ERAY) connector pinout

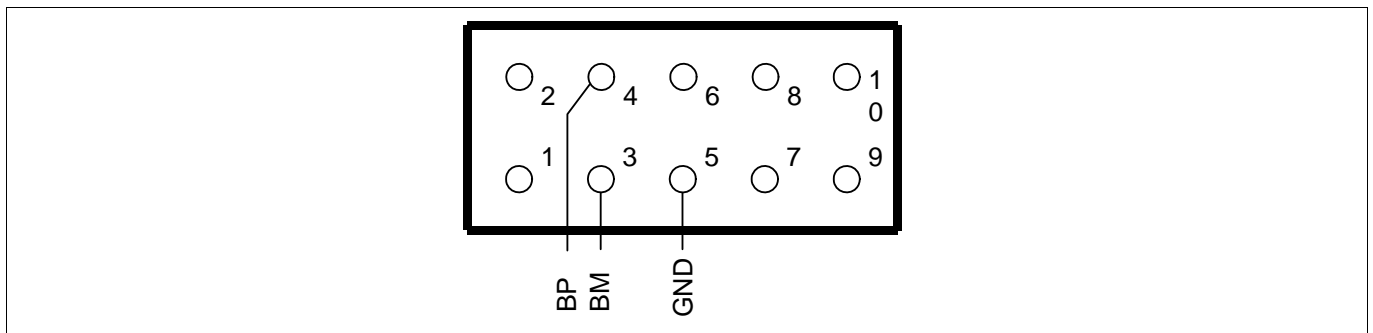

Figure 6-6 FlexRay™ (ERAY) connector pinout (IDC10)

6.6 CAN connector pinout

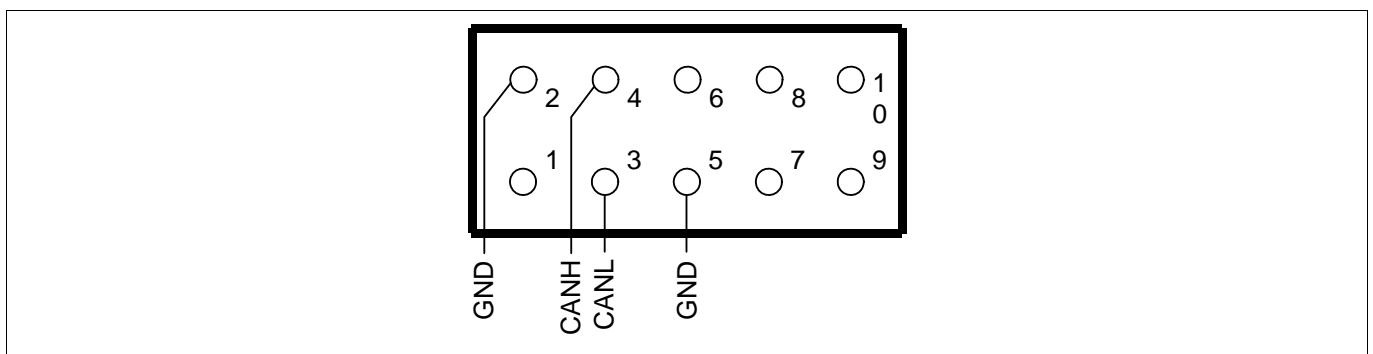

Figure 6-7 CAN connector pinout (IDC10)

Connector Pin Assignment

6.7 LIN connector pinout

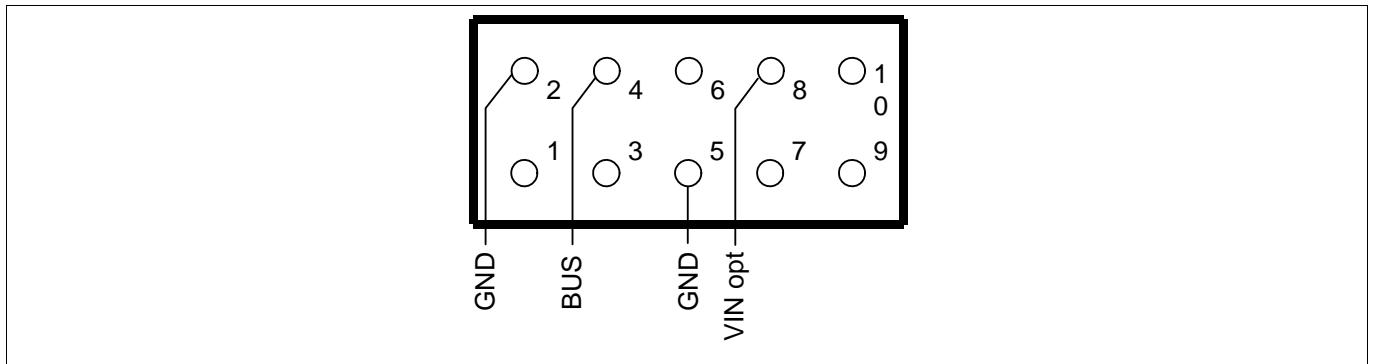

Figure 6-8 LIN connector pinout (IDC10)

6.8 HSCT connector pinout

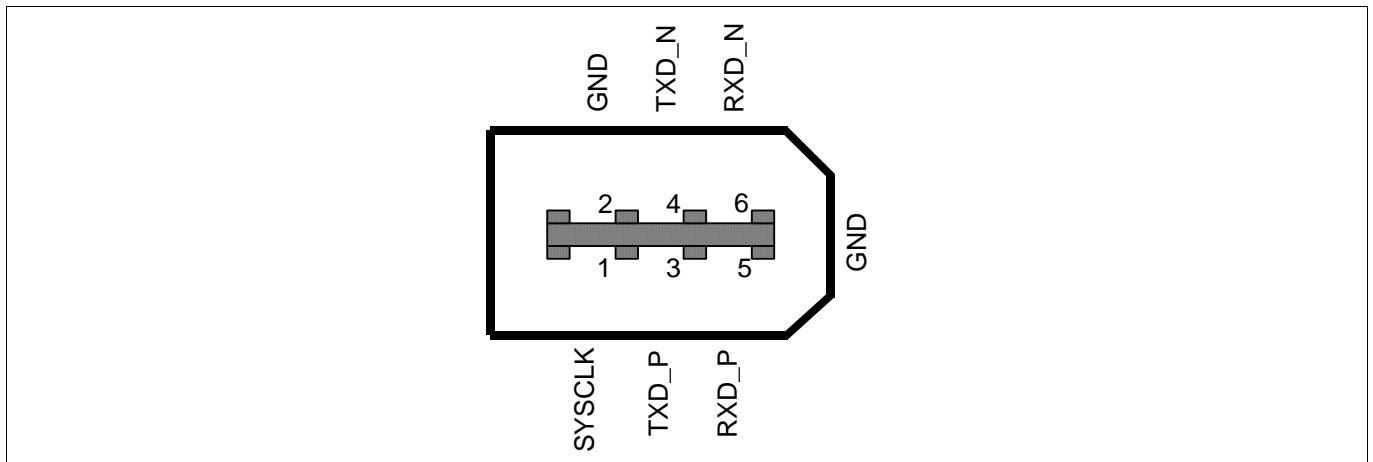

Figure 6-9 HSCT connector pinout (IEE1394 6-conductor)

6.9 Ethernet connector pinout

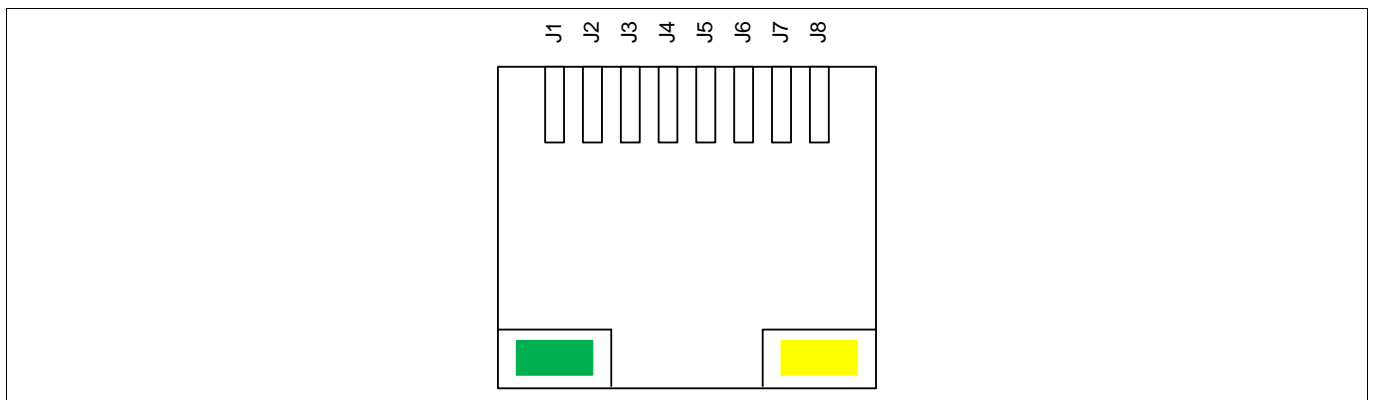

Figure 6-10 Ethernet connector pinout (RJ45)

Connector Pin Assignment

6.10 OCDS1 connector pinout

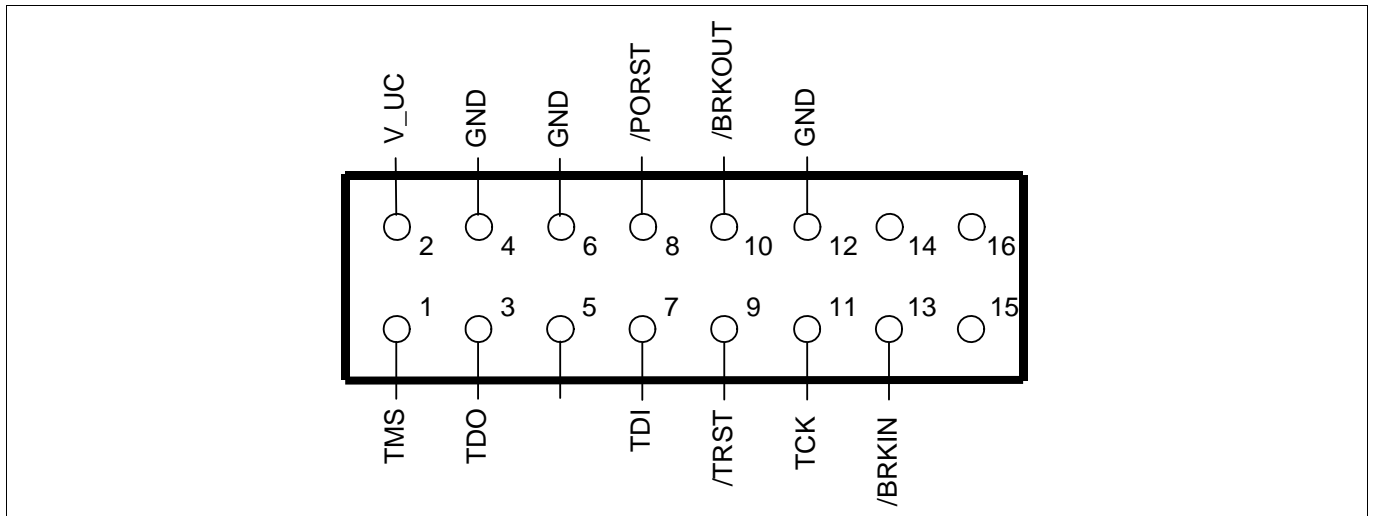

Figure 6-11 OCDS1 connector pinout (IDC16)

6.11 DAP connector pinout

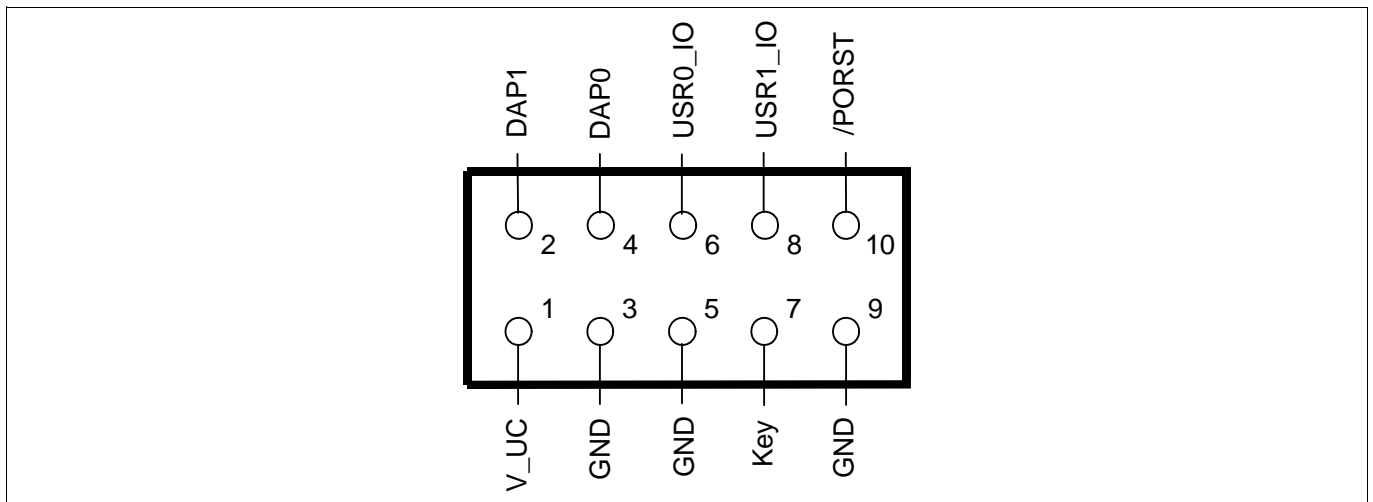

Figure 6-12 DAP connector pinout (Samtec FTSH10)

Connector Pin Assignment

6.12 ETK connector pinout

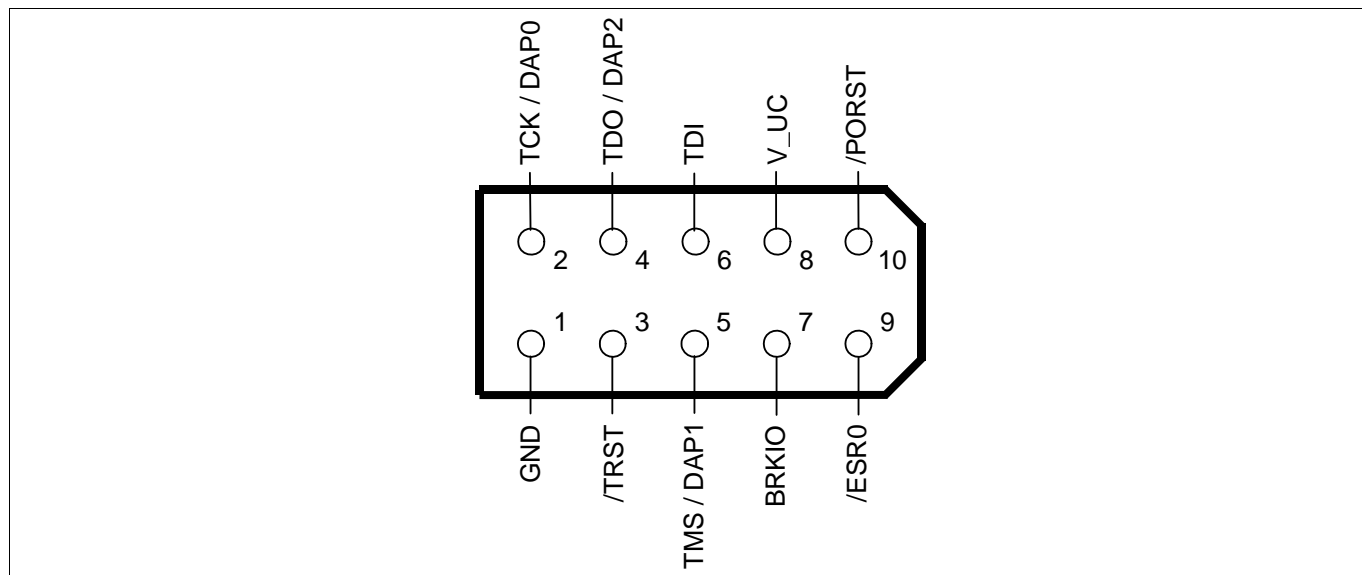

Figure 6-13 ETK connector pinout (Samtec TFM-105)

6.13 Ethernet miniWiggler power connector pinout

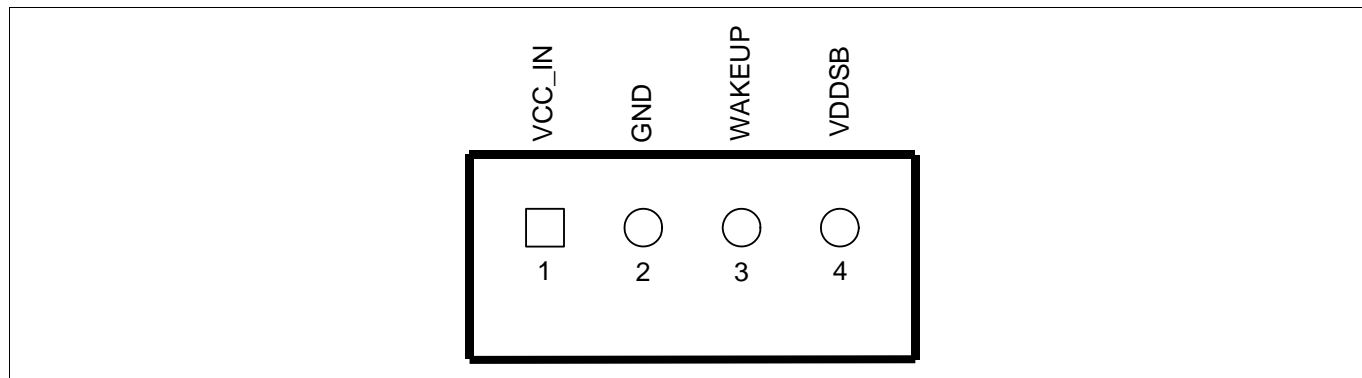

Figure 6-14 Ethernet miniWiggler connector pinout (JST B4B-PH)

Connector Pin Assignment

6.14 AGBT connector pinout

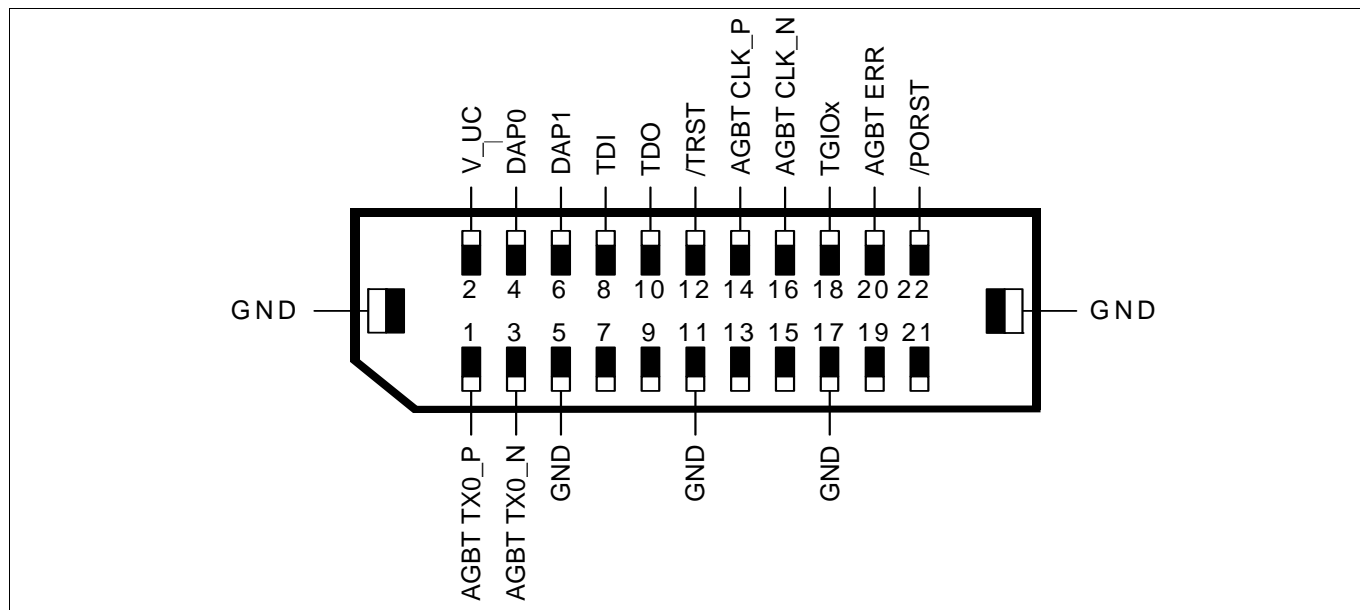

Figure 6-15 AGBT connector pinout (Samtec ASP-137969-01)

7 Schematic and Layout

7.1 Known problems

7.1.1 Known problems (TriBoard TC3X9 TH V1.0)

2 pads next to button P33.11 marked with GND are not connected to any net.

2 pads between X702 and X705 marked with GND are not connected to any net.

Shortcut between P22.0 and P22.1 on inner layer (can't be repaired).

D306 wrongly designated as P22.11 on Top Layer correct is P20.11.

7.1.2 Known problems (TriBoard TC3X9 TH V1.01)

No problems known.

7.1.3 Known problems (TriBoard TC3X9 V1.0)

No problems known.

7.2 Schematic

Schematic and Layout

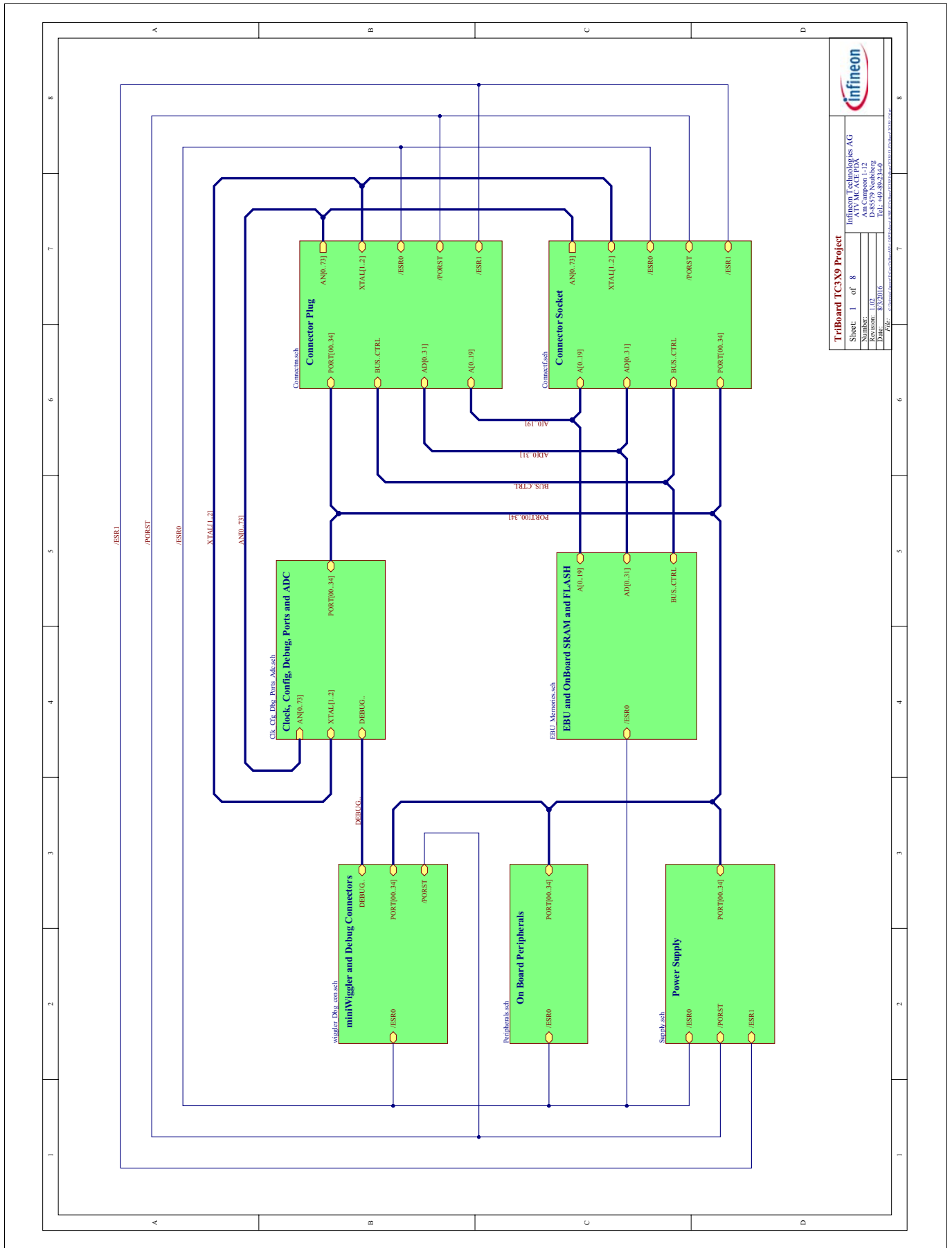

Figure 7-1 Schematic - Project

Schematic and Layout

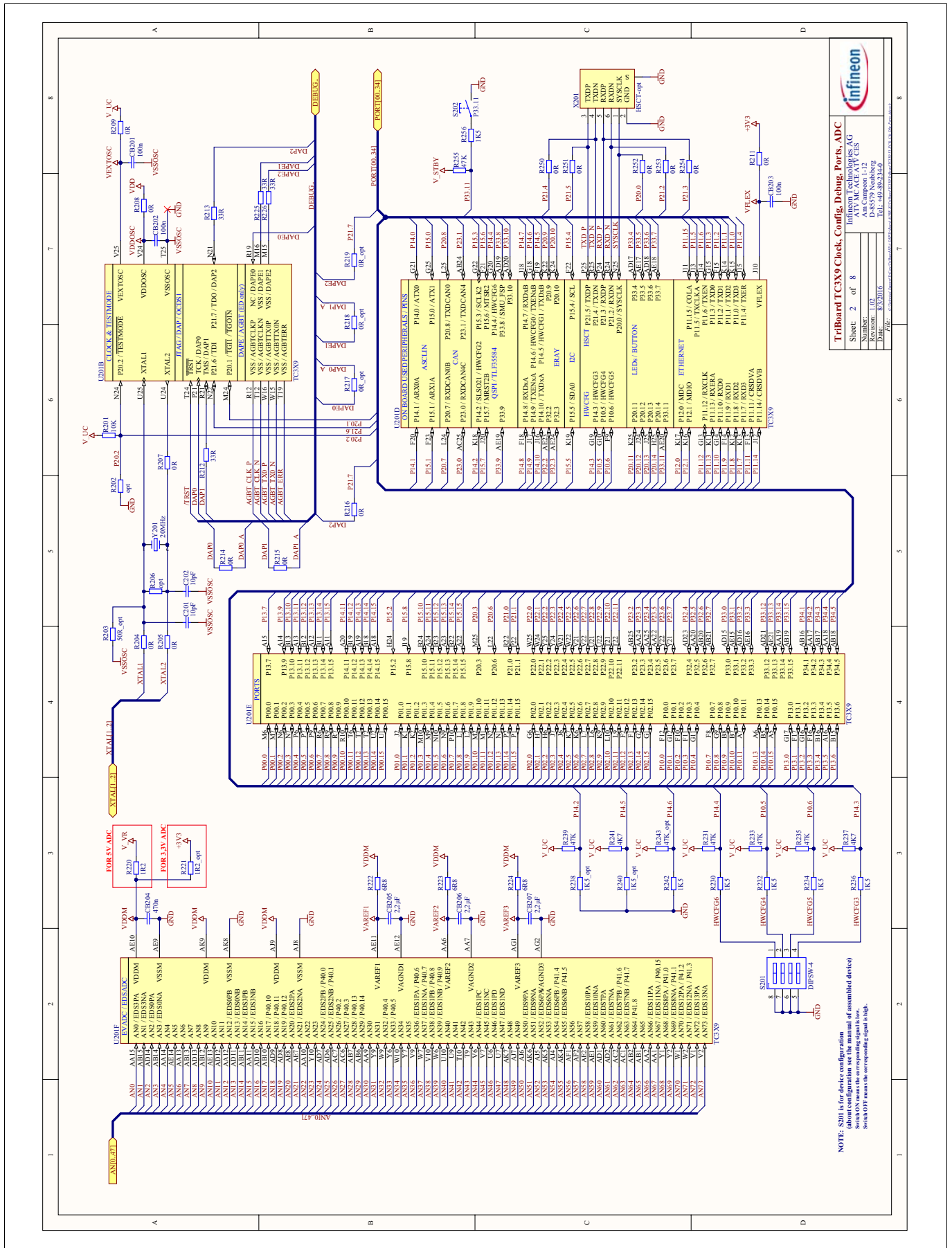

Figure 7-2 Schematic - Clock, Config, Debug, Ports and ADC

Schematic and Layout

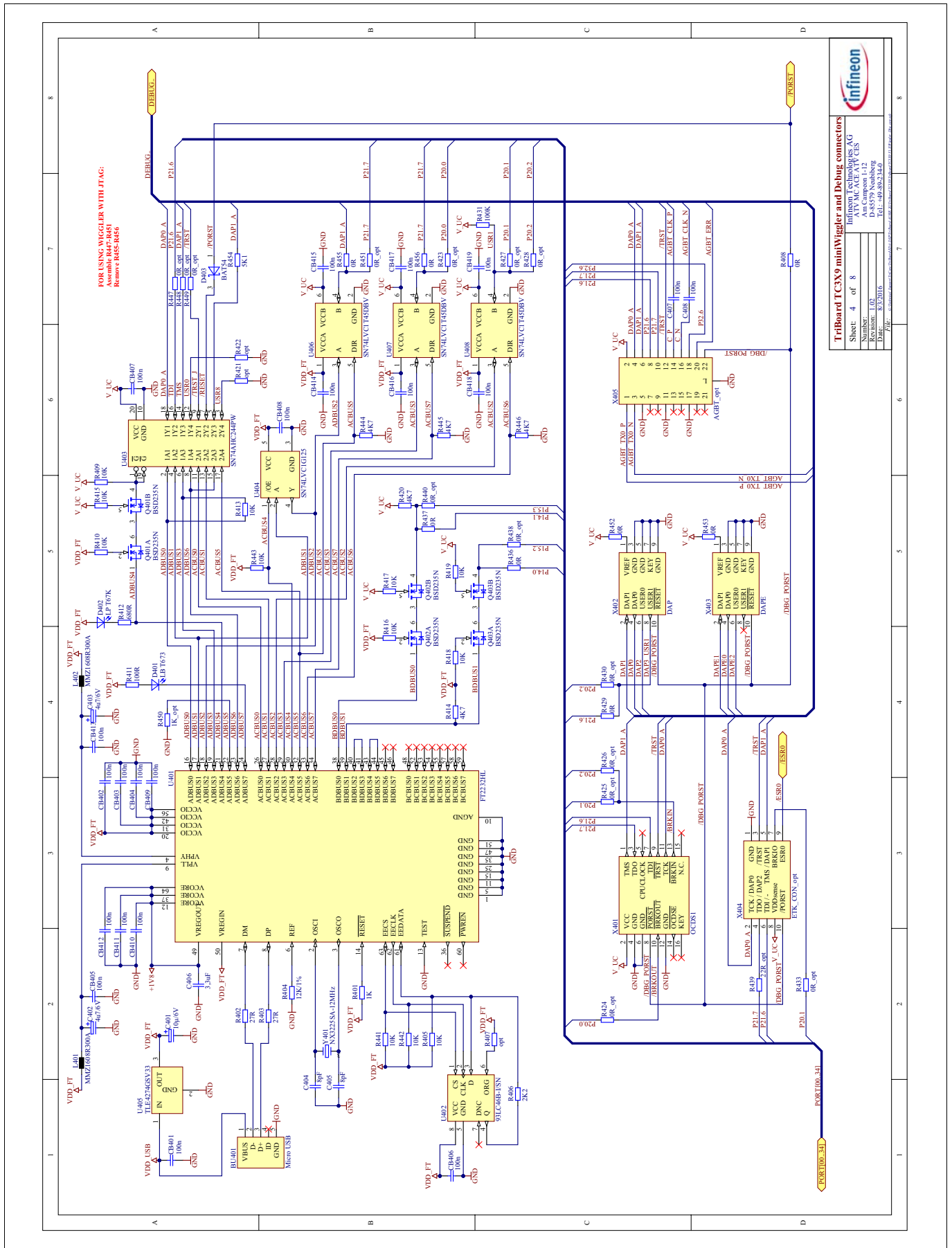
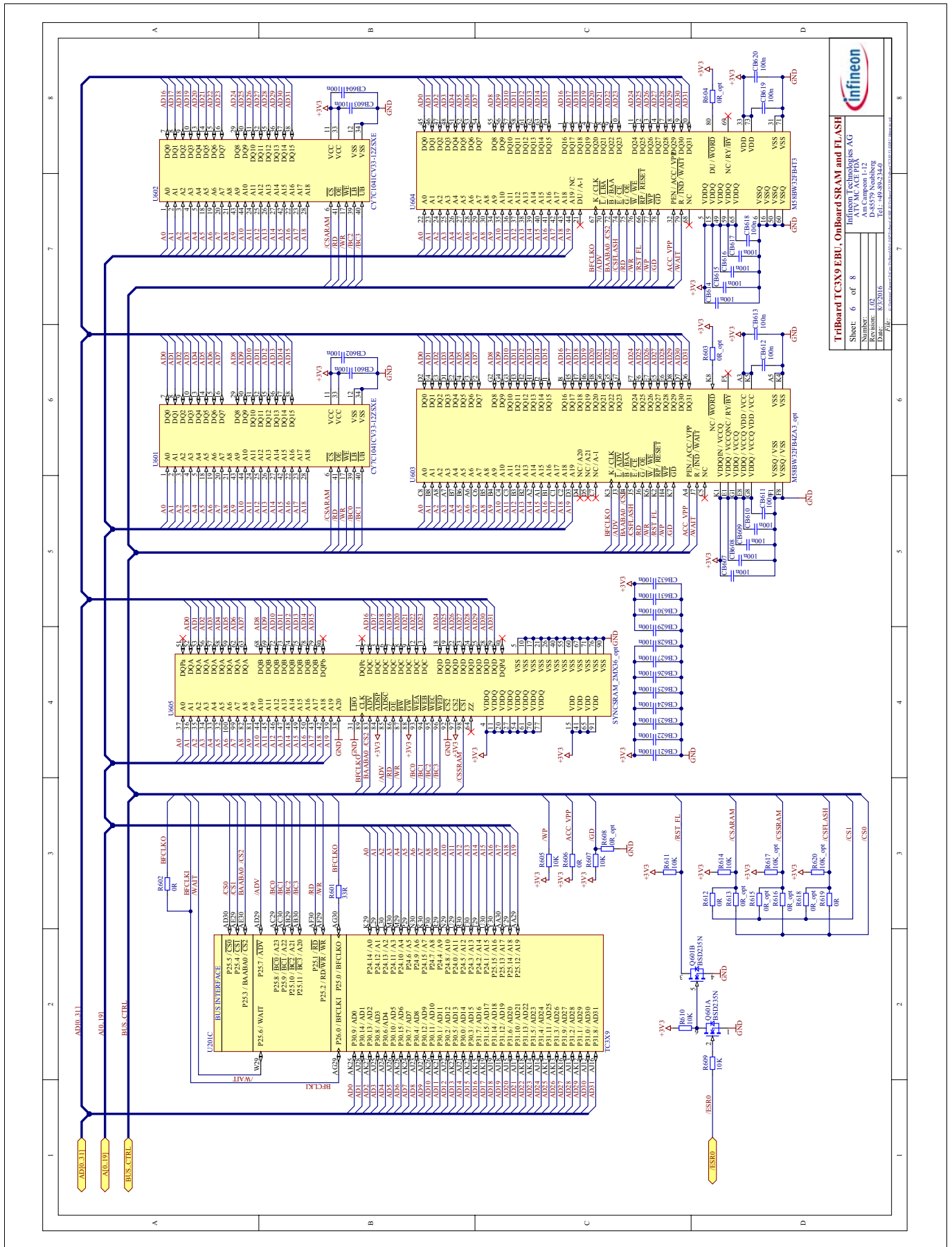

Figure 7-4 Schematic - miniWiggler JDS and Debug connectors

Schematic and Layout



TriBoard TC3X9 EBL, OnBoard SRAM and FLASH

Sheet: 6 of 8

Part Number: 69133

Number: 1-12

Date: 8.2.2016

File: ...

Infineon

Figure 7-6 Schematic - On Board SRAM and Flash

Schematic and Layout

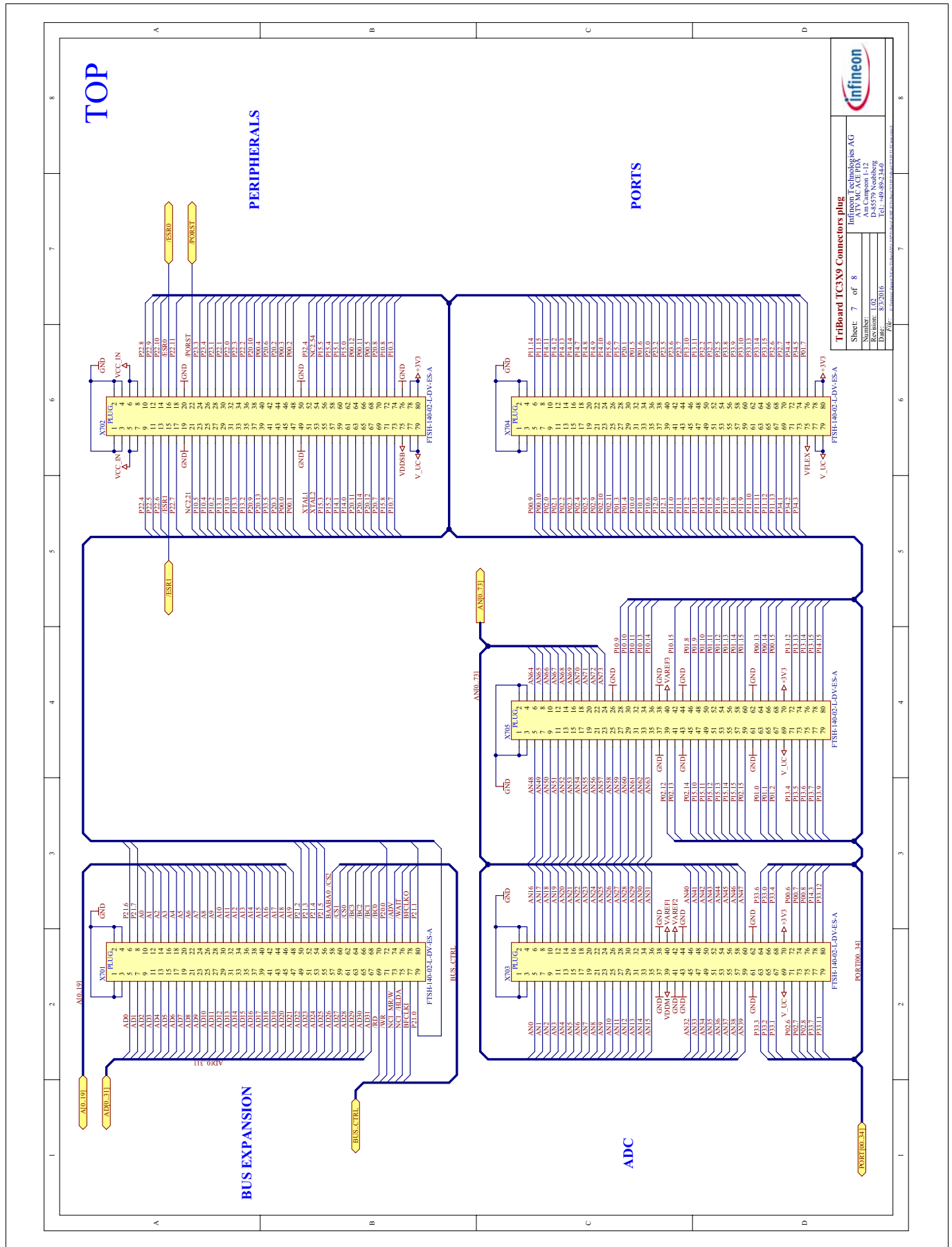

TriBoard TC3X9 Connectors plug

Infineon Technologies AG
 ATU VMC ACE PDK
 Am Campeon 1-12
 85305 Neuenkirchen
 Germany
 Date: 8/2/2016
 File: ...

Sheet: 7 of 8
 Number: 103
 Title: ...

Figure 7-7 Schematic - Connectors (Plug)

Schematic and Layout

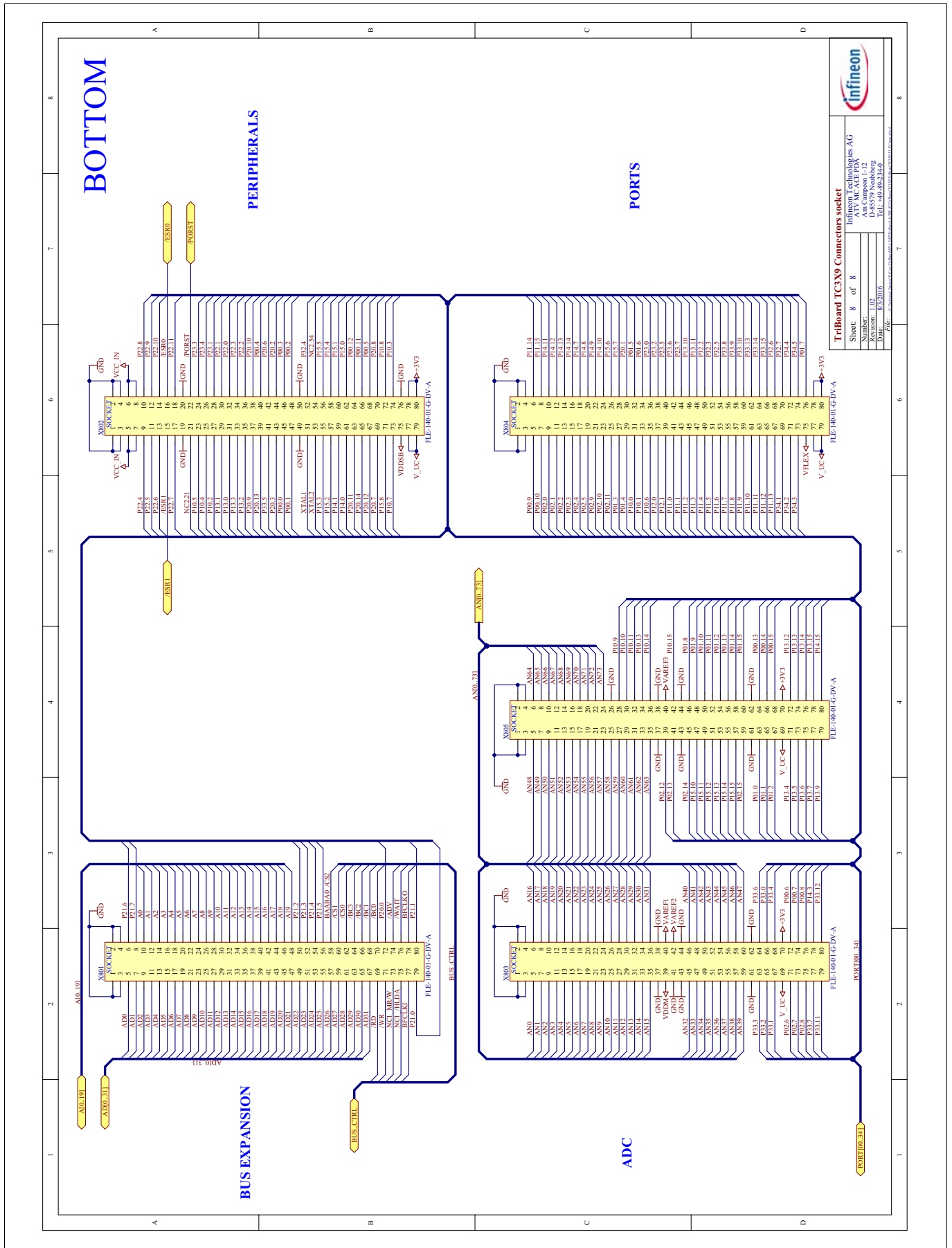

TriBoard TC3X9 Connectors socket

Sheet: 8 of 8	Infineon Technologies AG
Number: 1-12	Am Campeon 1-12
File: 8.3/2016	Infineon Technologies AG
Date: 8.3/2016	Tel: +49-89-23440

Figure 7-8 Schematic - Connectors (Socket)

Schematic and Layout

7.3 Layout

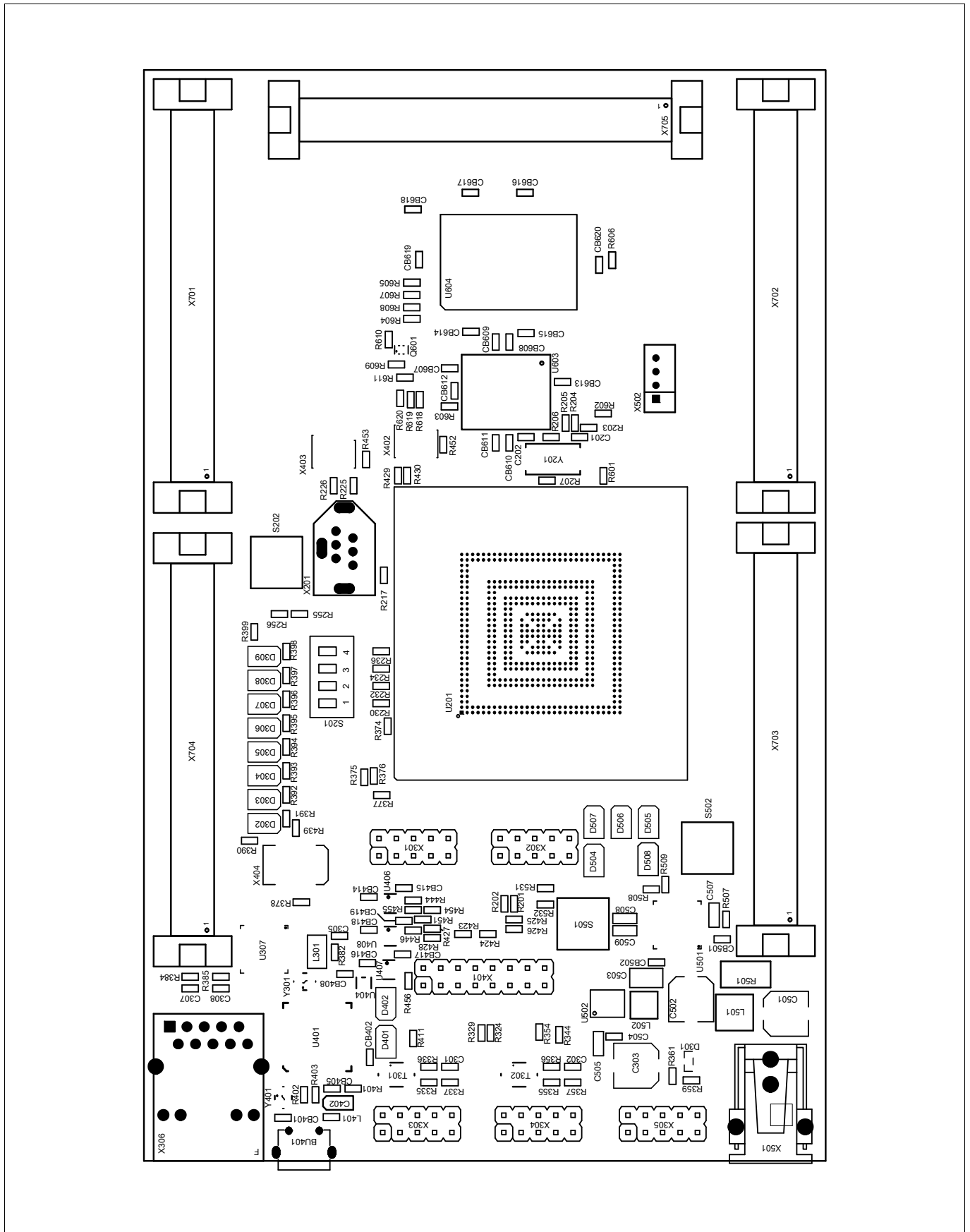

Figure 7-9 Component Plot Top Layer (TriBoard TC3X9 TH V1.0 and V1.01)

Schematic and Layout

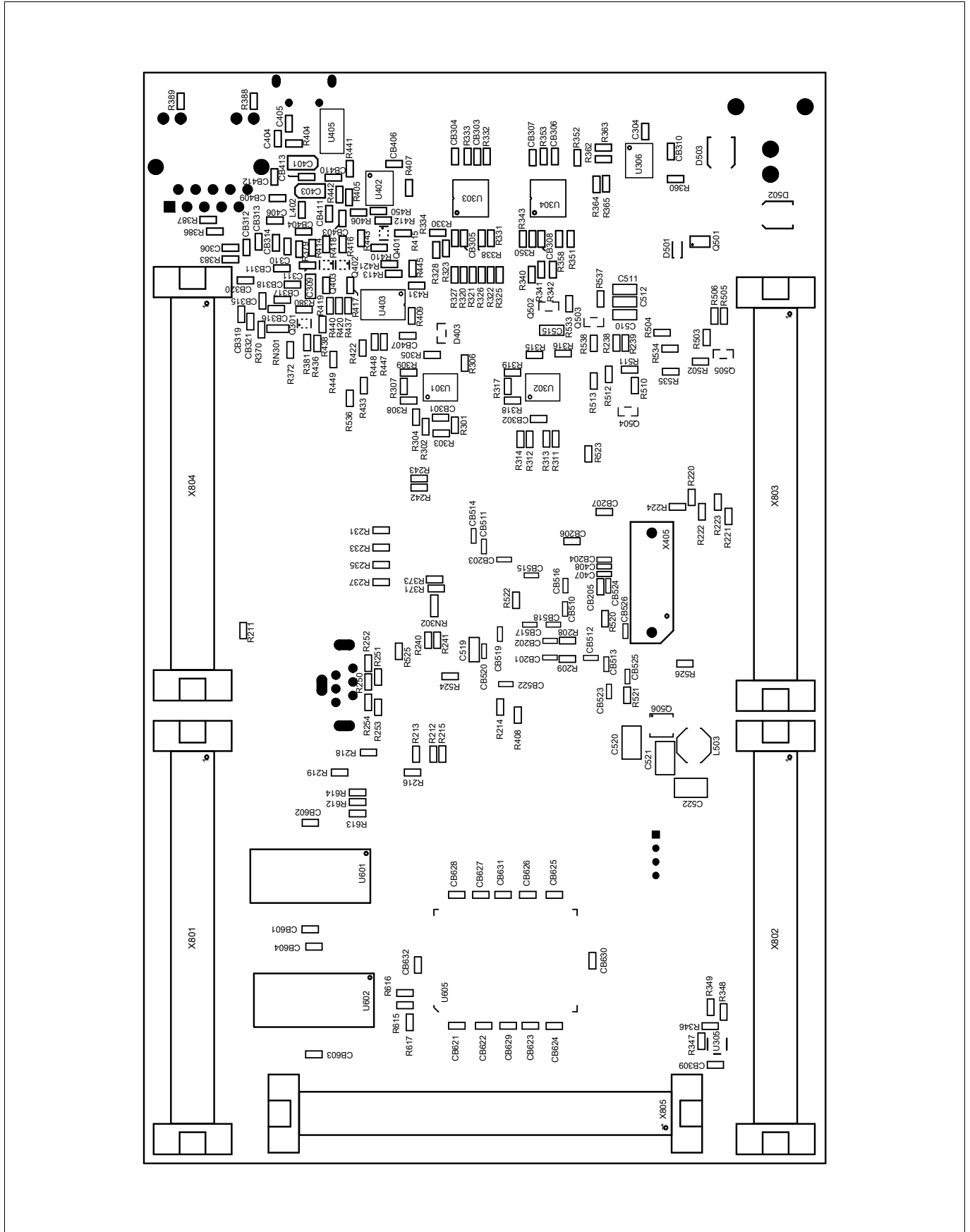

Figure 7-10 Component Plot Bottom Layer (TriBoard TC3X9 TH V1.0 and V1.01)

Schematic and Layout

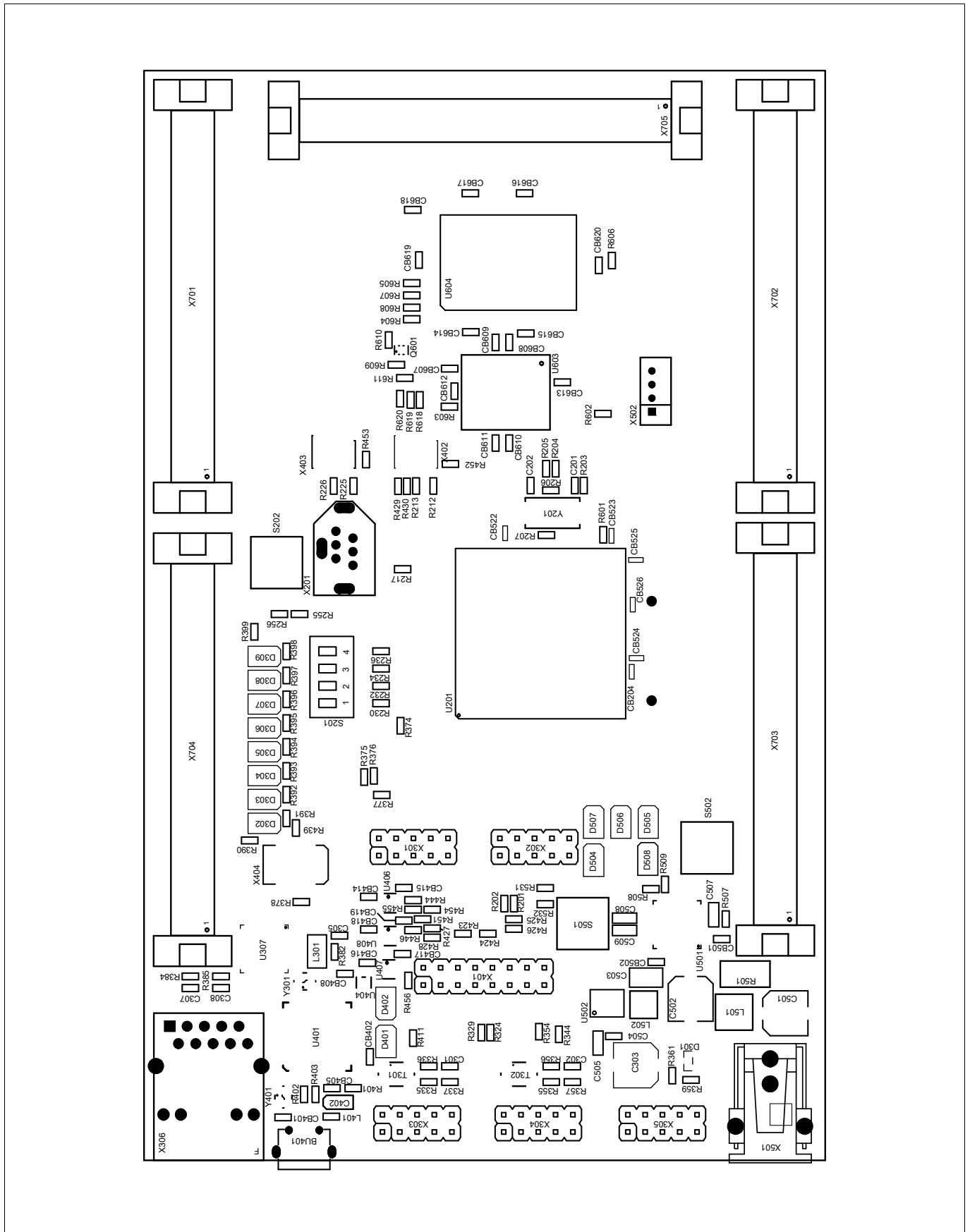

Figure 7-11 Component Plot Top Layer (TriBoard TC3X9 V1.0)

Schematic and Layout

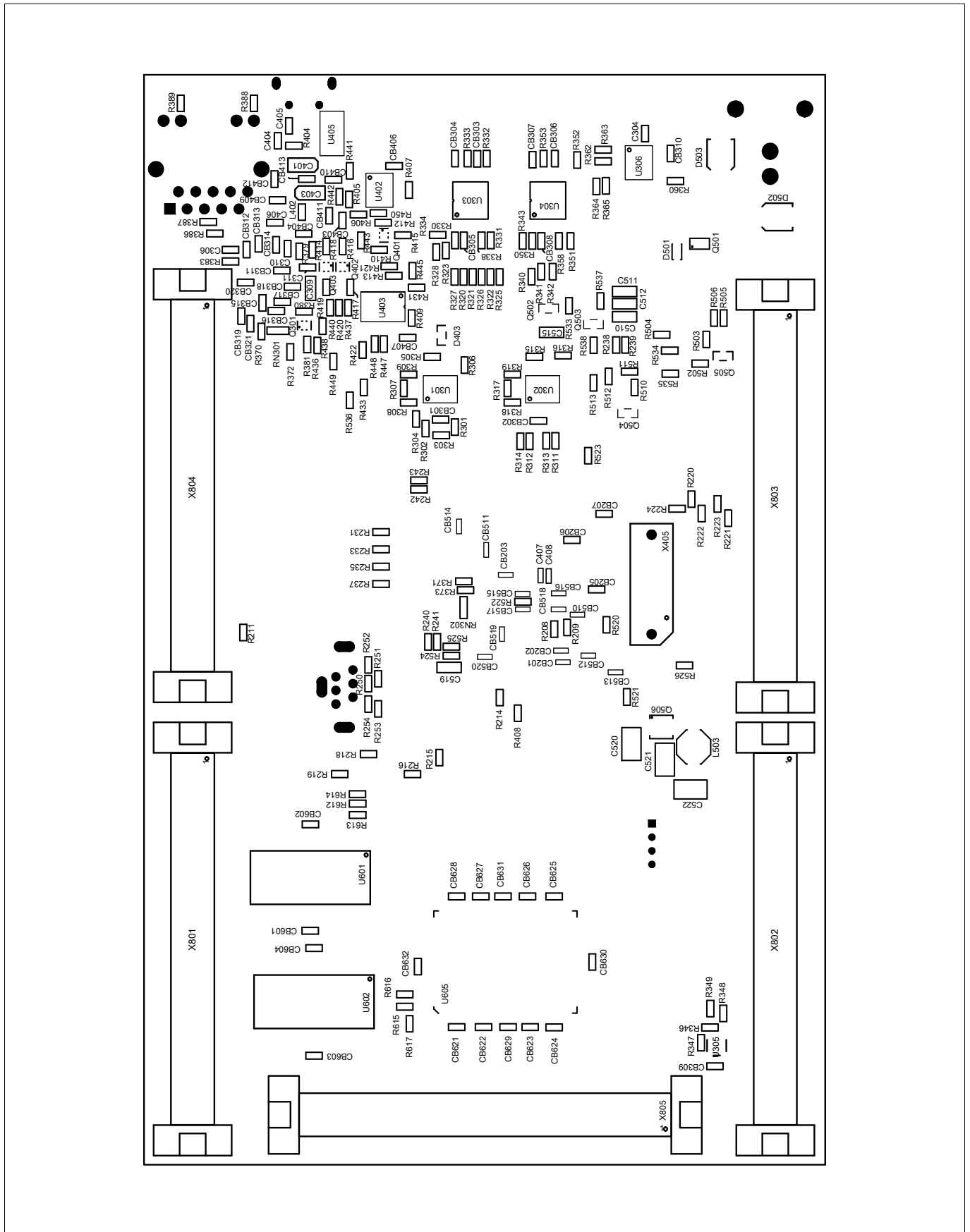

Figure 7-12 Component Plot Bottom Layer (TriBoard TC3X9 V1.0)

Schematic and Layout

7.4 Layout with Dimensioning

The following dimensions should be used for development of extension boards.

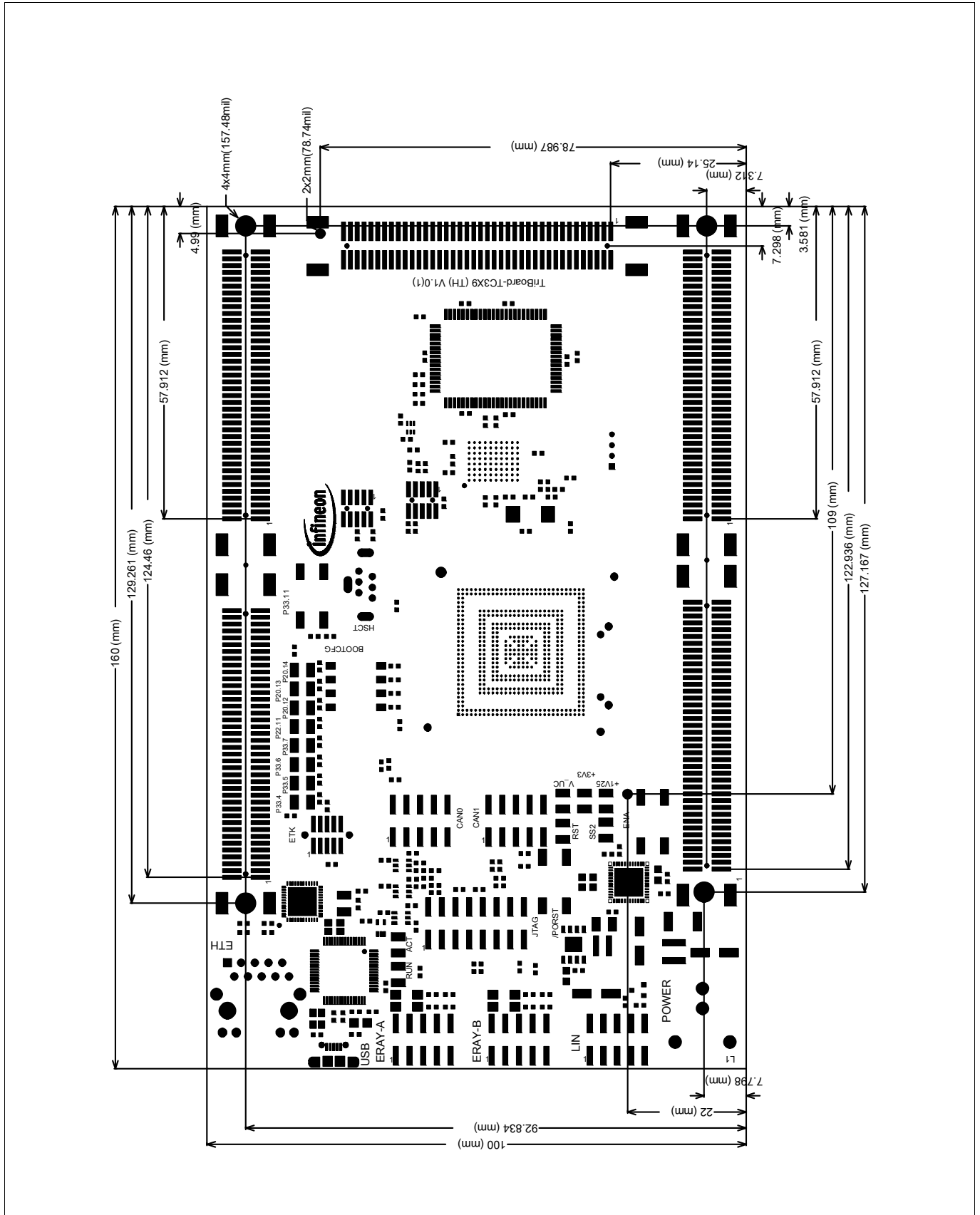

Figure 7-13 Dimensioning (mm)

Schematic and Layout

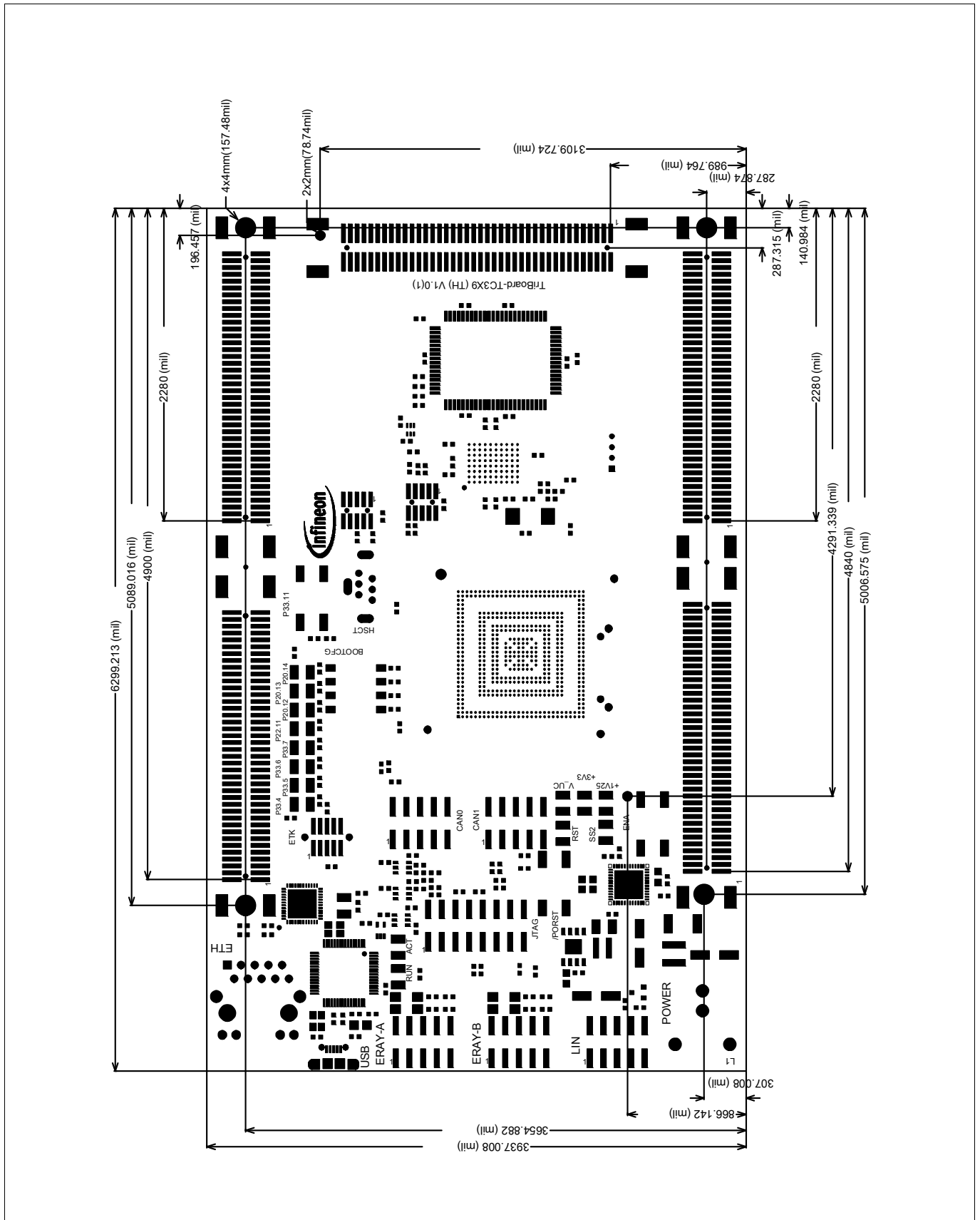

Figure 7-14 Dimensioning (mil)

The dimensioning is valid for all TriBoards.

Revision History

Page or Item	Subjects (major changes since previous revision)
V1.2, 2016-08	
	change to schematic version V1.02 (RC filter values for analog supply changed)
	switch off TLF35584 failsafe state by default
	Remove RGMII (Gigabit Ethernet not possible with this board)

Trademarks of Infineon Technologies AG

μ HVIC™, μ IPM™, μ PFC™, AU-ConvertIR™, AURIX™, C166™, CanPAK™, CIPOS™, CIPURSE™, CoolDP™, CoolGaN™, COOLIR™, CoolMOS™, CoolSET™, CoolSiC™, DAVE™, DI-POL™, DirectFET™, DrBlade™, EasyPIM™, EconoBRIDGE™, EconoDUAL™, EconoPACK™, EconoPIM™, EiceDRIVER™, eupec™, FCOS™, GaNpowIR™, HEXFET™, HITFET™, HybridPACK™, iMOTION™, IRAM™, ISOFACE™, IsoPACK™, LEDrivr™, LITIX™, MIPAQ™, ModSTACK™, my-d™, NovalithIC™, OPTIGA™, OptiMOS™, ORIGA™, PowIRaudio™, PowIRstage™, PrimePACK™, PrimeSTACK™, PROFET™, PRO-SIL™, RASIC™, REAL3™, SmartLEWIS™, SOLID FLASH™, SPOC™, StrongIRFET™, SupIRBuck™, TEMPFET™, TRENCHSTOP™, TriCore™, UHVIC™, XHP™, XMC™.

Trademarks updated November 2015

Other Trademarks

All referenced product or service names and trademarks are the property of their respective owners.

Edition 2016-08

Published by

Infineon Technologies AG

81726 Munich, Germany

© 2016 Infineon Technologies AG.

All Rights Reserved.

Do you have a question about any aspect of this document?

Email: erratum@infineon.com

Document reference

Doc_Number

IMPORTANT NOTICE

The information given in this document shall in no event be regarded as a guarantee of conditions or characteristics ("Beschaffheitsgarantie").

With respect to any examples, hints or any typical values stated herein and/or any information regarding the application of the product, Infineon Technologies hereby disclaims any and all warranties and liabilities of any kind, including without limitation warranties of non-infringement of intellectual property rights of any third party.

In addition, any information given in this document is subject to customer's compliance with its obligations stated in this document and any applicable legal requirements, norms and standards concerning customer's products and any use of the product of Infineon Technologies in customer's applications.

The data contained in this document is exclusively intended for technically trained staff. It is the responsibility of customer's technical departments to evaluate the suitability of the product for the intended application and the completeness of the product information given in this document with respect to such application.

For further information on technology, delivery terms and conditions and prices, please contact the nearest Infineon Technologies Office (www.infineon.com).

WARNINGS

Due to technical requirements products may contain dangerous substances. For information on the types in question please contact your nearest Infineon Technologies office.

Except as otherwise explicitly approved by Infineon Technologies in a written document signed by authorized representatives of Infineon Technologies, Infineon Technologies' products may not be used in any applications where a failure of the product or any consequences of the use thereof can reasonably be expected to result in personal injury.

X-ON Electronics

Largest Supplier of Electrical and Electronic Components

Click to view similar products for [Power Management IC Development Tools](#) category:

Click to view products by [Infineon](#) manufacturer:

Other Similar products are found below :

[EVB-EP5348UI](#) [MIC23451-AAAYFL EV](#) [MIC5281YMME EV](#) [124352-HMC860LP3E](#) [DA9063-EVAL](#) [ADP122-3.3-EVALZ](#) [ADP130-0.8-EVALZ](#) [ADP130-1.8-EVALZ](#) [ADP1740-1.5-EVALZ](#) [ADP1870-0.3-EVALZ](#) [ADP1874-0.3-EVALZ](#) [ADP199CB-EVALZ](#) [ADP2102-1.25-EVALZ](#) [ADP2102-1.875EVALZ](#) [ADP2102-1.8-EVALZ](#) [ADP2102-2-EVALZ](#) [ADP2102-3-EVALZ](#) [ADP2102-4-EVALZ](#) [AS3606-DB](#) [BQ25010EVM](#) [BQ3055EVM](#) [ISLUSBI2CKIT1Z](#) [LM2734YEVAL](#) [LP38512TS-1.8EV](#) [EVAL-ADM1186-1MBZ](#) [EVAL-ADM1186-2MBZ](#) [ADP122UJZ-REDYKIT](#) [ADP166Z-REDYKIT](#) [ADP170-1.8-EVALZ](#) [ADP171-EVALZ](#) [ADP1853-EVALZ](#) [ADP1873-0.3-EVALZ](#) [ADP198CP-EVALZ](#) [ADP2102-1.0-EVALZ](#) [ADP2102-1-EVALZ](#) [ADP2107-1.8-EVALZ](#) [ADP5020CP-EVALZ](#) [CC-ACC-DBMX-51](#) [ATPL230A-EK](#) [MIC23250-S4YMT EV](#) [MIC26603YJL EV](#) [MIC33050-SYHL EV](#) [TPS60100EVM-131](#) [TPS65010EVM-230](#) [TPS71933-28EVM-213](#) [TPS72728YFFEVM-407](#) [TPS79318YEQEV](#) [UCC28810EVM-002](#) [XILINXPWR-083](#) [LMR22007YMINI-EVM](#)