

IM69D127V11

IP57 dust and water resistant PDM digital XENSIV™ MEMS microphone

Description

The IM69D127V11 is an ultra-high performance digital PDM MEMS microphone designed for applications which require a very high SNR (low self-noise) and low distortion (high AOP) and which is also IP57 robust to dust and water.

Best-in-class signal-to-noise ratio (SNR) of 69dB(A) enables far field and low volume audio pick-up. The flat frequency response (40Hz low-frequency roll-off) and tight manufacturing tolerance improve performance of multi-microphone (array) applications.

The digital microphone ASIC contains an extremely low-noise preamplifier and a high-performance sigma-delta ADC. Different power modes can be selected in order to suit specific clock frequency and current consumption requirements.

Each IM69D127V11 microphone is calibrated with an advanced Infineon calibration algorithm, resulting in low sensitivity tolerances (± 1 dB).

Features

- Component level IP57 dust and water resistant
- Dynamic range of 102dB
 - Signal to noise ratio of 69dB(A) SNR
 - <1% total harmonic distortions up to 123dB SPL
 - Acoustic overload point at 127dB SPL
- Accurate sensitivity matching (± 1 dB) for beam forming applications
- Flat frequency response with low frequency roll-off at 40Hz
- Power optimized modes determined by PDM clock frequency
- Package dimensions: 3.60mm x 2.50mm x 1.00mm
- PDM Output
- Omnidirectional pickup pattern

Typical applications

- Active Noise Cancellation (ANC) headphones and wireless earbuds
- Devices with Voice User Interface (VUI)
 - Smart speakers
 - Home automation
 - IoT devices
- High quality audio capturing
 - Cameras
 - Laptops and tablets
 - Conference systems

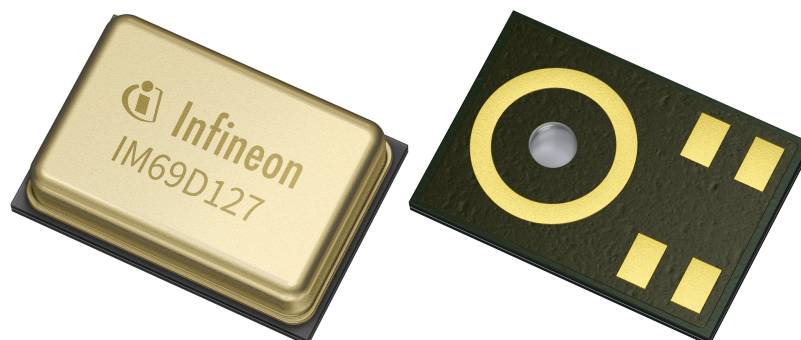

Block diagram

Block diagram

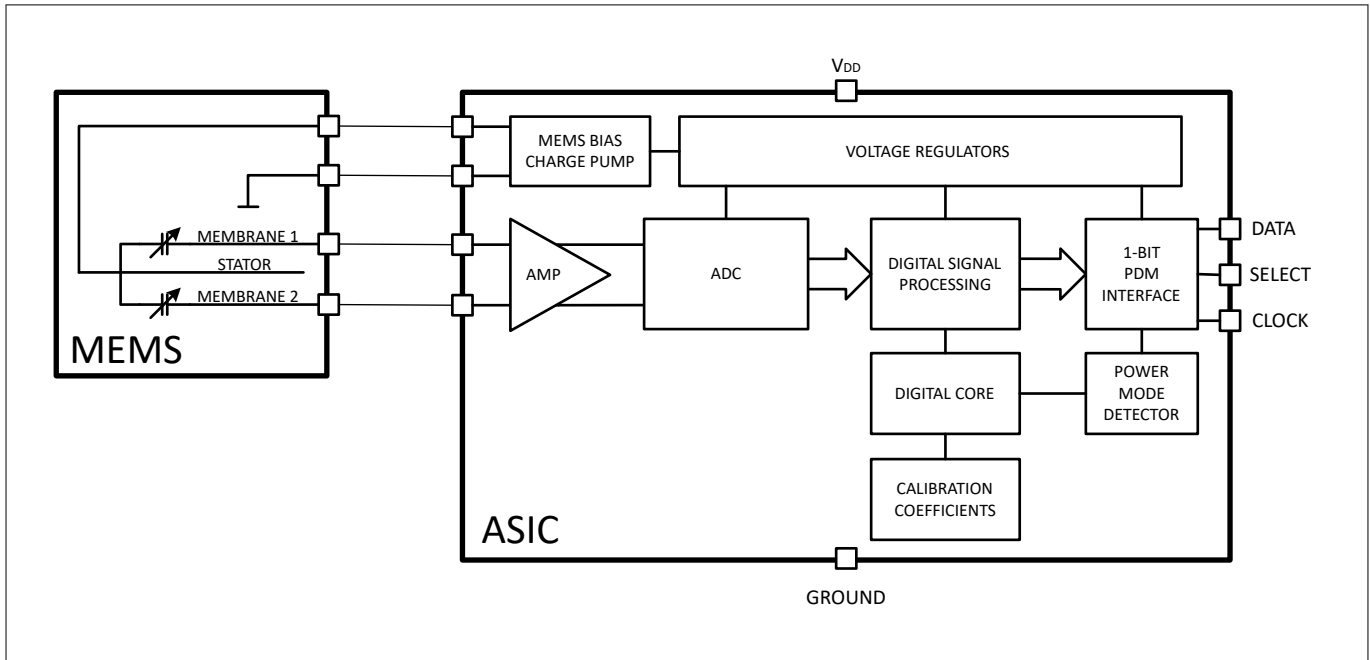

Figure 1 IM69D127V11 block diagram.

Product validation

Technology qualified for industrial applications.

Ready for validation in industrial applications according to the relevant tests of IEC 60747 and 60749 or alternatively JEDEC47/20/22.

Environmental robustness

Infineon’s latest Sealed Dual Membrane MEMS technology delivers high ingress protection (IP57) at a microphone level. The sealed MEMS design prevents water or dust from entering between membrane and backplate, preventing mechanical blockage or electric leakage issues commonly observed in MEMS microphones. Microphones built with the Sealed Dual Membrane technology can be used to create IP68 devices, requiring only minimal mesh protection.

Table 1 Environmental robustness

Test Standard	Test Condition
IP5x dust resistance ¹⁾	Arizona dust A4 coarse, vertical orientation , sound hole upwards, 10 cycles (15 minutes sedimentation, 6 sec blowing)
IPx7 water immersion ²⁾	Temporary immersion of 1 meters for 30 minutes. Microphone tested 2 hours after removal

¹ The number "5" stands for the dust ingress rating or the capacity to withstand the effects of fine, abrasive dust particles.

² The "7" specifies the higher water immersion rating.

Table of contents

	Description	1
	Features	1
	Typical applications	1
	Block diagram	2
	Product validation	2
	Environmental robustness	2
	Table of contents	3
1	Typical performance characteristics	4
2	Acoustic characteristics	5
2.1	Free field frequency response	6
3	Electrical parameters and characteristics	7
3.1	Absolute maximum ratings	7
3.2	Electrical parameters	7
3.3	Electrical characteristics	8
3.4	Digital interface timing specifications	9
3.5	PDM channel configurations	9
3.6	Audio DC offset	9
3.7	Stereo PDM operation	10
4	Package information	11
5	Footprint and stencil recommendation	12
6	Packing information	13
7	Reflow soldering and board assembly	14
8	Reliability specifications	16
	Revision history	17
	Glossary	17
	Disclaimer	18

Typical performance characteristics

1 Typical performance characteristics

Test conditions: $V_{DD} = 1.8V$, $f_{CLK} = 3.072MHz$, no load on DATA

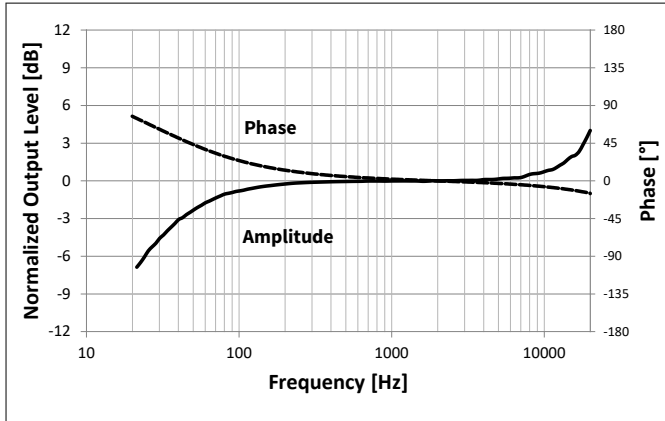

Figure 2 Typical amplitude and phase response

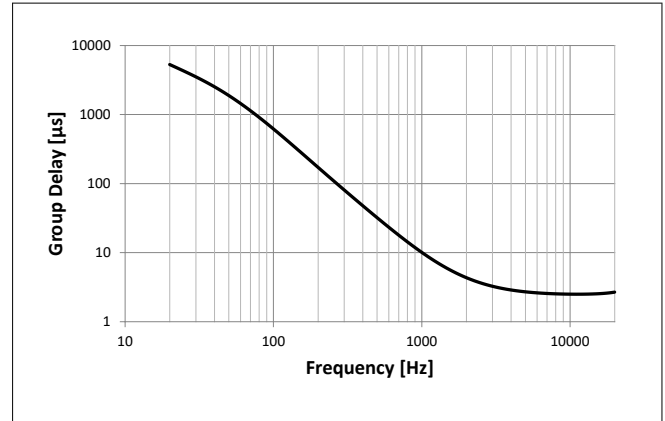

Figure 3 Typical group delay vs frequency

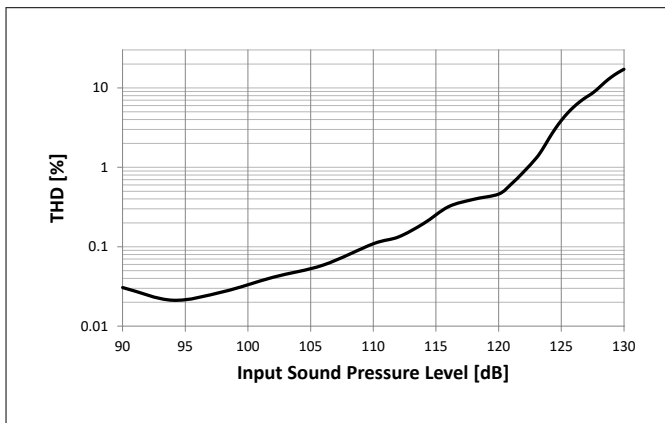

Figure 4 Typical THD vs SPL

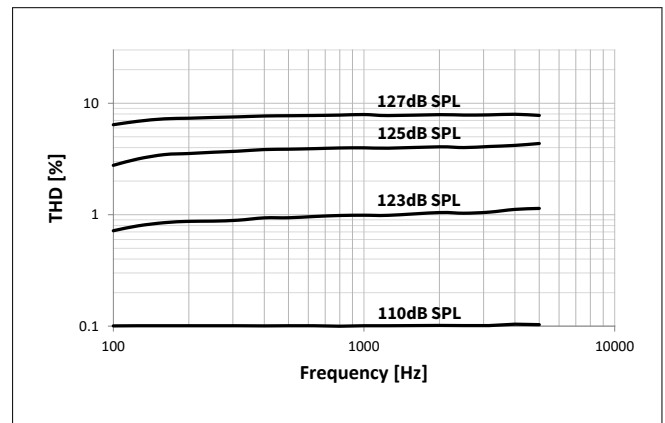

Figure 5 Typical THD vs frequency

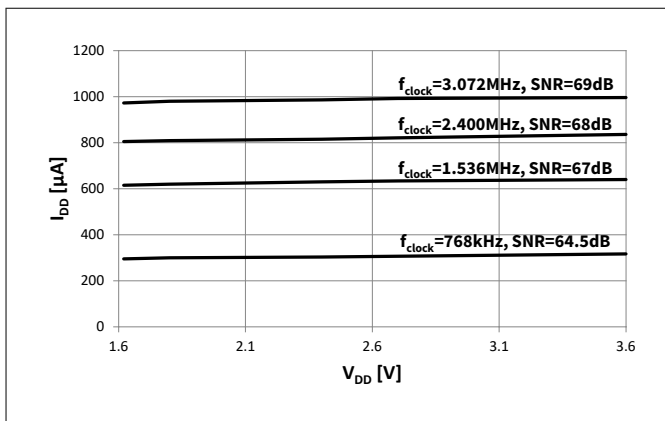

Figure 6 Typical I_{DD} vs V_{DD}

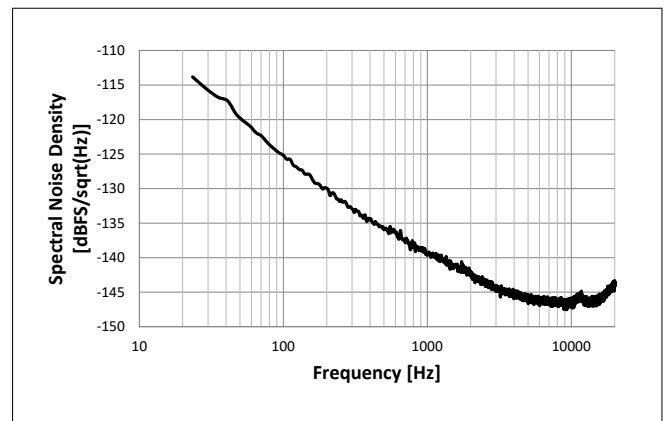

Figure 7 Typical noise floor (unweighted)

Acoustic characteristics

2 Acoustic characteristics

Test conditions (unless otherwise specified in the table): $V_{DD} = 1.8V$, $f_{CLK} = 3.072MHz$, $T_A = 25^{\circ}C$, 55% R.H., Audio bandwidth 20Hz to 20kHz, Select pin grounded, no load, $T_{edge} = 9ns$.

Table 2 IM69D127V11 acoustic specifications

Parameter	Symbol	Values			Unit	Note or Test Condition
		Min.	Typ.	Max.		
Sensitivity		-35	-34	-33	dBFS	1kHz, 94dB SPL, all operating modes
Acoustic overload point	AOP		127		dB SPL	THD = 10%, all operating modes
Signal to Noise ratio	$f_{clock}=3.072MHz$	SNR		69	dB (A)	A-Weighted 20Hz to 8kHz bandwidth, A-Weighted;
	$f_{clock}=2.4MHz$			68		
	$f_{clock}=1.536MHz$			67		
	$f_{clock}=768kHz$			65		
Total harmonic distortion	94dB SPL	THD		0.5	%	Measuring 2nd to 5th harmonics; 1kHz. All power modes
	123dB SPL			1		
	127dB SPL			10		
Low frequency cutoff point		$f_{C LP}$		40	Hz	-3dB point relative to 1kHz
Group delay	250Hz			113	μs	
	600Hz			23		
	1kHz			9		
	4kHz			3		
Phase response	75Hz			30	°	
	1kHz			2		
	3kHz			-2		
Directivity			Omnidirectional			Pickup pattern
Polarity			Positive pressure increases density of 1's, negative pressure decreases density of 1's in data output.			

Acoustic characteristics

2.1 Free field frequency response

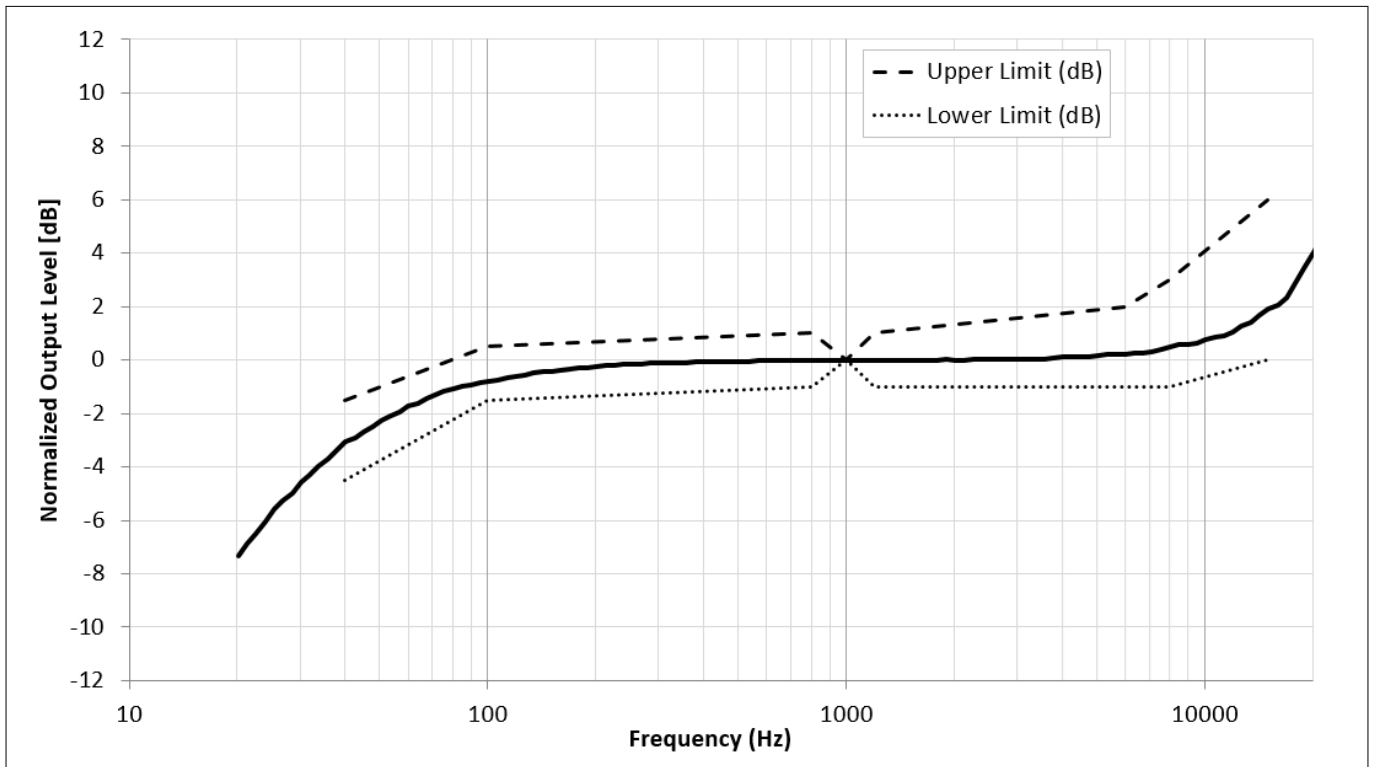

Figure 8 IM69D127V11 free field frequency response

Table 3 IM69D127V11 free field frequency response, normalised to 1kHz sensitivity value.

Frequency (Hz)	Upper Limit (dB)	Lower Limit (dB)
40	-1.5	-4.5
100	+0.5	-1.5
800	+1	-1
1000	0	0
1200	+1	-1
6000	+2	-1
8000	+3	-1
15000	+6	0

Electrical parameters and characteristics

3 Electrical parameters and characteristics

3.1 Absolute maximum ratings

Stresses at or above the listed maximum ratings may affect device reliability or cause permanent device damage. Functional device operation at these conditions is not guaranteed.

Table 4 Absolute maximum ratings

Parameter	Symbol	Values		Unit	Note / Test Condition
		Min.	Max.		
Voltage on any pin	V_{max}		4	V	
Storage temperature	T_S	-40	100	°C	
Operating temperature	T_A	-40	85	°C	

3.2 Electrical parameters

Table 5 Electrical parameters and digital interface input

Parameter		Symbol	Values			Unit	Note / Test Condition
			Min.	Typ.	Max.		
Supply voltage		V_{DD}	1.65	1.8	3.6	V	A 100nF bypass capacitor should be placed close to the microphone's VDD pin to ensure best SNR performance
Clock frequency range	Operating modes	f_{clock}	2.9	3.072	3.3	MHz	Intermediate frequencies between those listed cannot be used
			2.2	2.4	2.6		
			1.38	1.536	1.7		
	450	768	850	kHz			
Standby mode			250			DATA = high-Z	
V_{DD} ramp-up time					50	ms	Time until $V_{DD} \geq V_{DD_min}$
Clock duty cycle			40		60	%	At PDM clock frequency range from minimum to typical value
			45		55		At PDM clock frequency range from typical to maximum value
Clock rise/fall time		t_{CR}, t_{CF}			13	ns	
Input logic low level		V_{IL}	-0.3		$0.35 \times V_{DD}$	V	
Input logic high level		V_{IH}	$0.65 \times V_{DD}$		$V_{DD} + 0.3$	V	
Output load capacitance on DATA		C_{load}			200	pF	

Electrical parameters and characteristics

3.3 Electrical characteristics

Test conditions (unless otherwise specified in the table): $V_{DD}=1.8V$, $T_A=25^{\circ}C$, 55% R.H.

Table 6 General electrical characteristics

Parameter		Symbol	Values			Unit	Note / Test Condition	
			Min.	Typ.	Max.			
Current consumption	$f_{clock}=3.072MHz$	I_{DD}		980	1200	μA	Output load <5pF	
	$f_{clock}=2.4MHz$			800	950			
	$f_{clock}=1.536MHz$			620	740			
	$f_{clock}=768kHz$			300	350			
	Standby mode	$I_{standby}$			50			
	Clock Off mode	I_{clock_off}			10			CLOCK pulled low
Short circuit current			1		20	mA	Grounded DATA pin	
Power supply rejection		PSR			-75	dBFS	$V_{DD}=1.8V+100mV_{pp}$ sine wave, $f=40Hz$ to $100Hz$	
					-80		$V_{DD}=1.8V+100mV_{pp}$ sine wave, $f=100Hz$ to $20kHz$	
Startup time	$\pm 0.5dB$ sensitivity accuracy				20	ms	Time to start up in all operating modes after V_{DD_min} and CLOCK have been applied	
	$\pm 0.2dB$ sensitivity accuracy				50			
Mode switch time	$\pm 0.5dB$ sensitivity accuracy				20	ms	Time to switch between operating modes. V_{DD} remains on during the mode switch	
	$\pm 0.2dB$ sensitivity accuracy				50			
Hysteresis width		V_{hys}	$0.1xV_{DD}$			V		
Output logic low level		V_{OL}			$0.3xV_{DD}$	V	$I_{out}=2mA$	
Output logic high level		V_{OH}	$0.7xV_{DD}$				$I_{out}=2mA$	
Delay time for DATA driven		t_{DD}	40		80	ns	Delay time from CLOCK edge ($0.5xV_{DD}$) to DATA driven	
Delay time for DATA high-Z ³⁾		t_{HZ}	5		30	ns	Delay time from CLOCK edge ($0.5xV_{DD}$) to DATA high impedance state	
Delay time for DATA valid ⁴⁾		t_{DV}			100	ns	Delay time from CLOCK edge ($0.5xV_{DD}$) to DATA valid ($<0.3xV_{DD}$ or $>0.7xV_{DD}$). Load on data: $C_{load}=100pF$, $R_{load}=100k\Omega$	
Power-on behavior		Idle tone is output over PDM within 3ms of applying VDD and CLK, remains until a valid microphone signal is available. Idle tones consists of alternating 1s and 0s, representing a zero input signal.						

³⁾ t_{hold} is depended on C_{load}

⁴⁾ Load on data: $C_{load}=100pF$, $R_{load}=100k\Omega$

3.4 Digital interface timing specifications

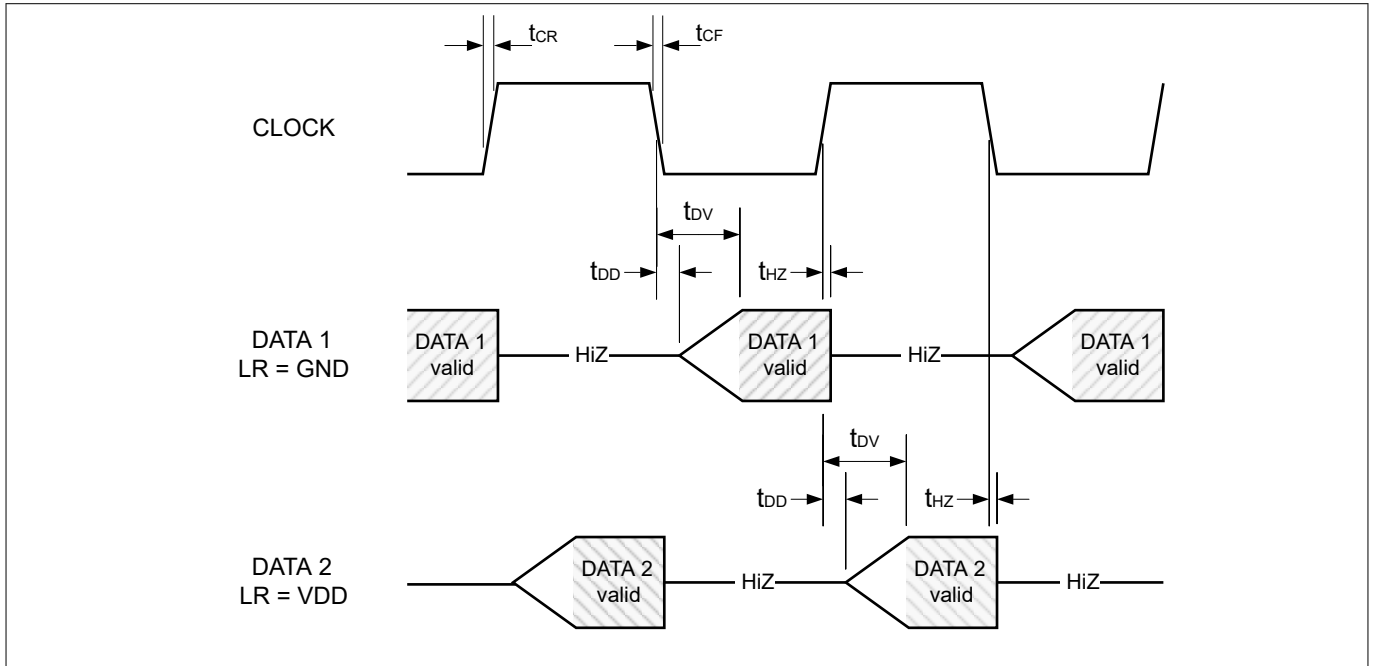

Figure 9 IM69D127V11 timing diagram

3.5 PDM channel configurations

Table 7 PDM channel configuration using L/R pin.

Channel	Data driven	Data high-Z	L/R connection
DATA1	Falling clock edge	Rising clock edge	GND
DATA2	Rising clock edge	Falling clock edge	V _{DD}

3.6 Audio DC offset

The DC output level encoded in the DC bit stream is determined by the L/R state on startup. In each case the DC output level is stable over time and does not vary with input signal level.

Table 8 DC output level using L/R pin

LR state	DC output level (typical)	Unit
LR = GND	-80	dBFS
LR = VDD	-40	dBFS

3.7 Stereo PDM operation

The IM69D127V11 is designed to function in circuits with one or two microphones on the PDM bus. When two microphones are connected, data is transmitted alternately according to the L/R pin status of each microphone. When two microphones are connected to a shared PDM bus, the power modes of both microphones will be the same as both are controlled by the same PDM clock. The performance is unchanged relative to a single microphone per bus configuration.

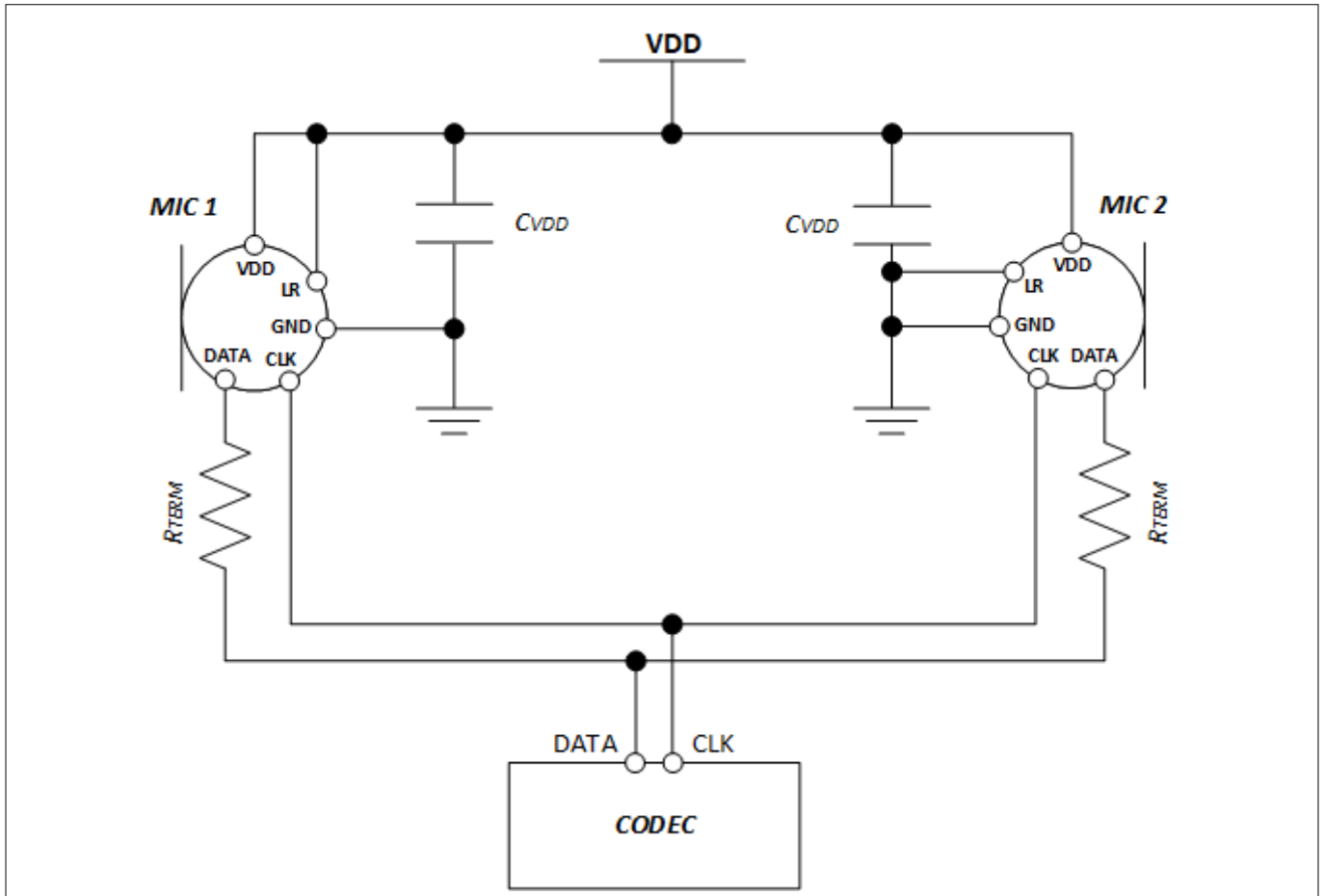

Figure 10 IM69D127V11 stereo mode configuration

Note: For best performance it is strongly recommended to place a 100nF ($C_{VDD_typical}$) capacitor between V_{DD} and ground. The capacitor should be placed as close to V_{DD} as possible. A termination resistor (R_{TERM}) of about 100Ω may be added to reduce the ringing and overshoot on the output signal.

4 Package information

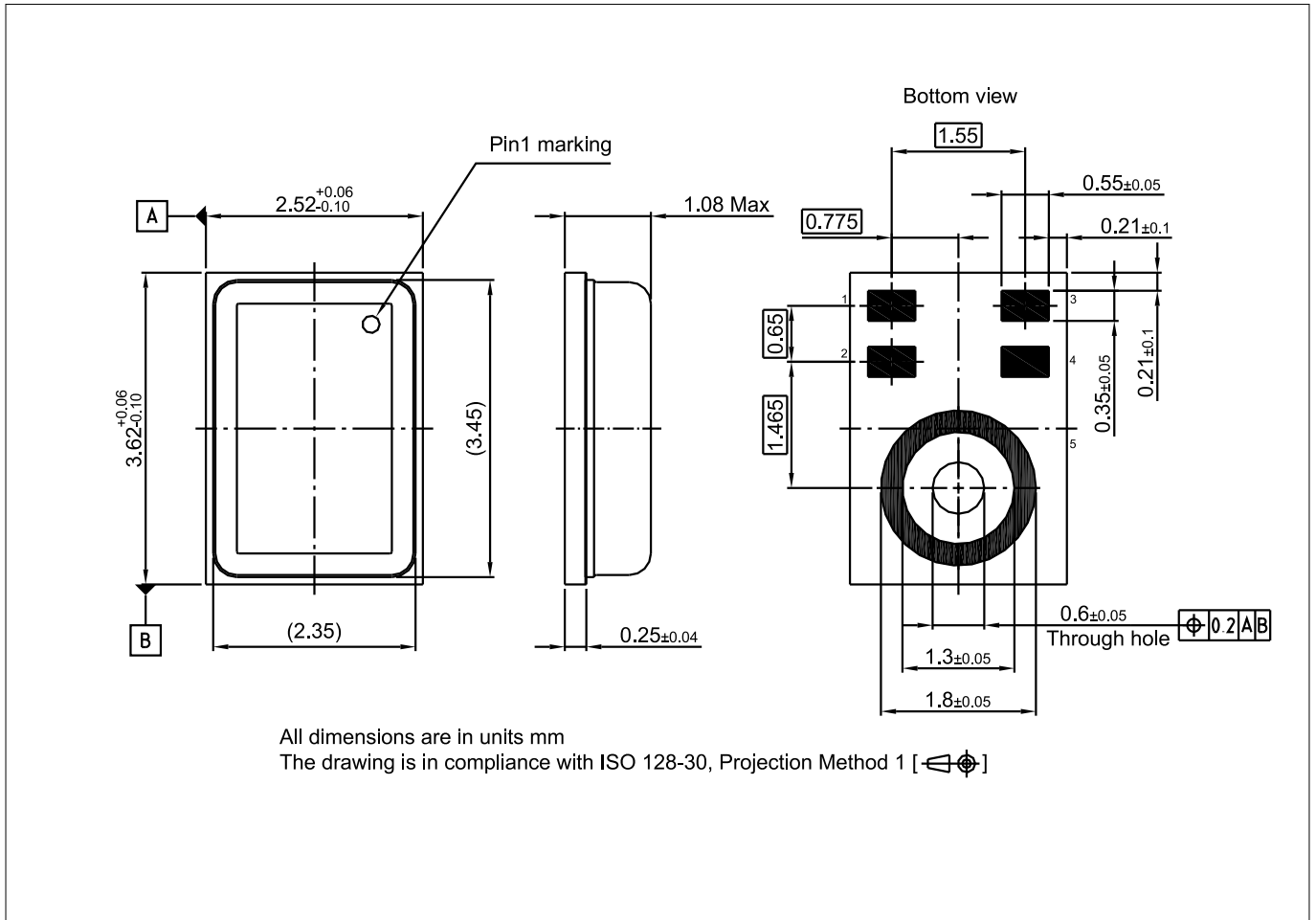

Figure 11 IM69D127V11 package drawing.

Table 9 IM69D127V11 pin configuration

Pin Number	Name	Description
1	DATA	PDM data output
2	V _{DD}	Power supply
3	CLOCK	PDM clock input
4	SELECT	PDM left/right select
5	Ground	Ground

Footprint and stencil recommendation

5 Footprint and stencil recommendation

The acoustic port hole diameter in the PCB should be larger than the acoustic port hole diameter of the MEMS Microphone to ensure optimal performance. A PCB sound port size of radius 0.4 mm (diameter 0.8mm) is recommended.

The board pad and stencil aperture recommendations shown in Figure 12 are based on Solder Mask Defined (SMD) pads. The specific design rules of the board manufacturer should be considered for individual design optimizations or adaptations.

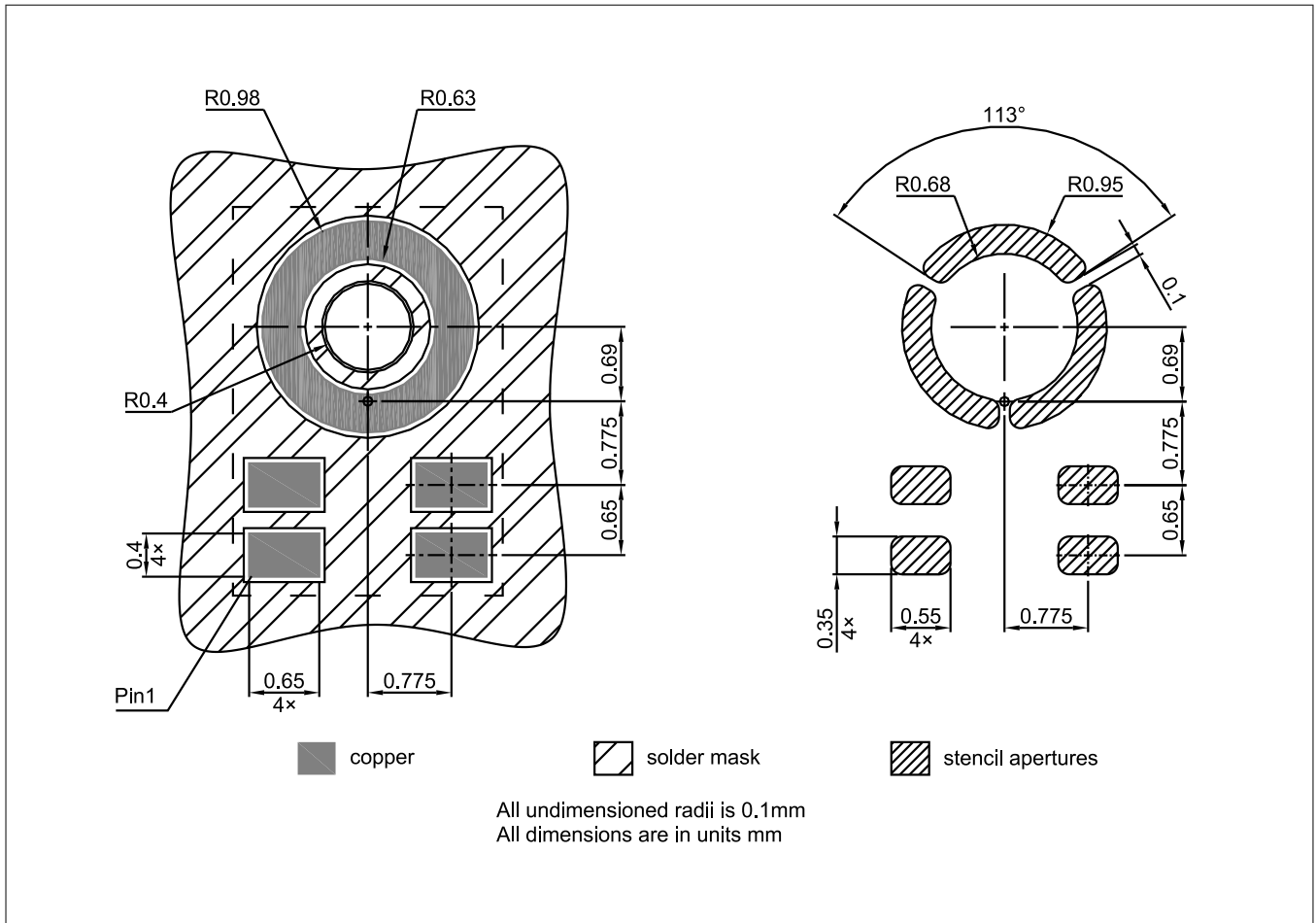

Figure 12 IM69D127V11 footprint and stencil recommendation

Note: Dimensions are in millimeters unless otherwise specified

6 Packing information

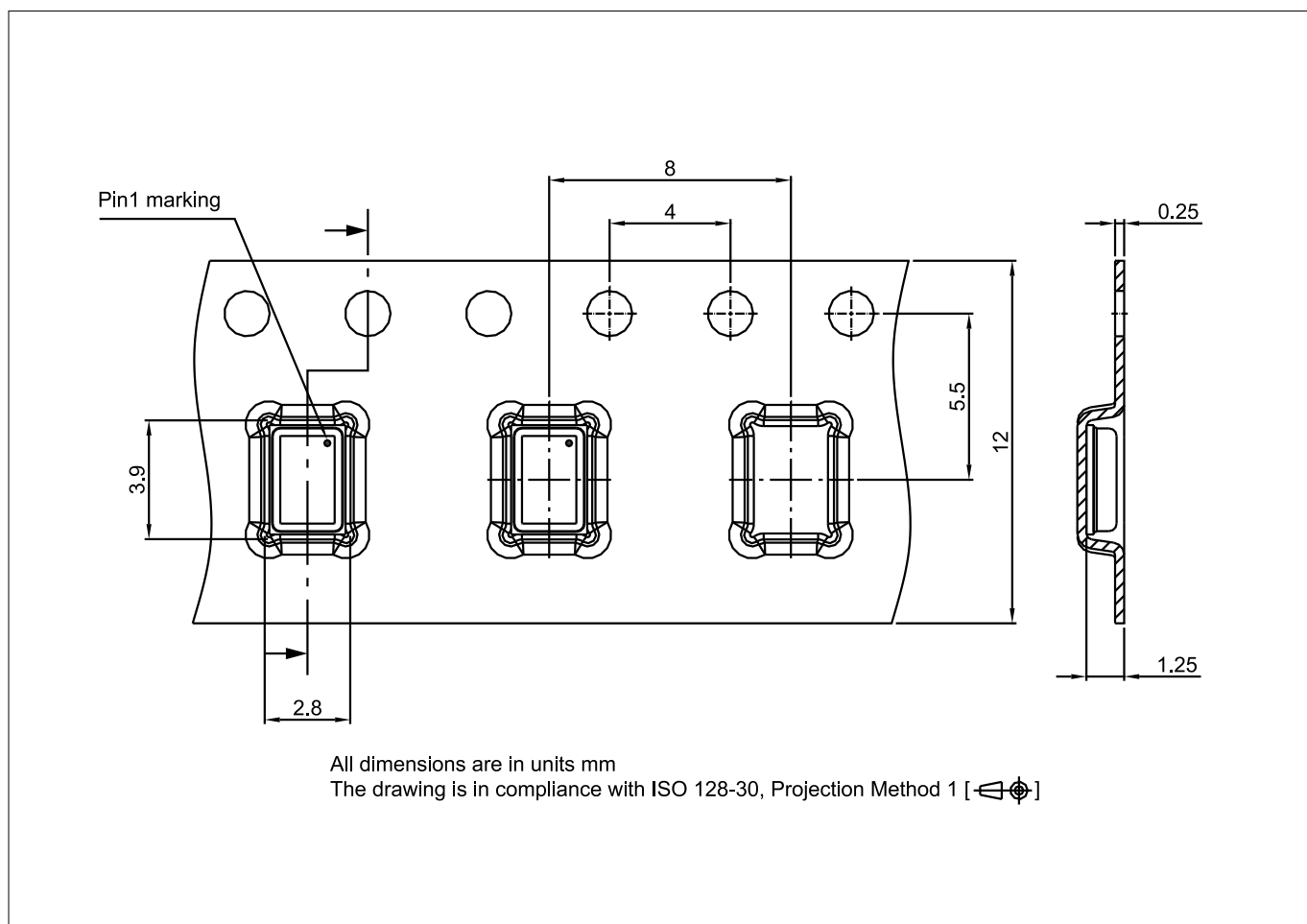

Figure 13 IM69D127V11 packing information

Table 10 IM69D127V11 packing information

Product	Type code	Reel diameter	Quantity per reel
IM69D127V11	I69D10	330 mm	5000

7 Reflow soldering and board assembly

Infineon MEMS microphones are qualified in accordance with the IPC/JEDEC J-STD-020D-01. The moisture sensitivity level of MEMS microphones is rated as MSL1. For PCB assembly of the MEMS microphone the widely used reflow soldering using a forced convection oven is recommended.

The soldering profile should be in accordance with the recommendations of the solder paste manufacturer to reach an optimal solder joint quality. The reflow profile shown in Figure 14 is recommended for board manufacturing with Infineon MEMS microphones.

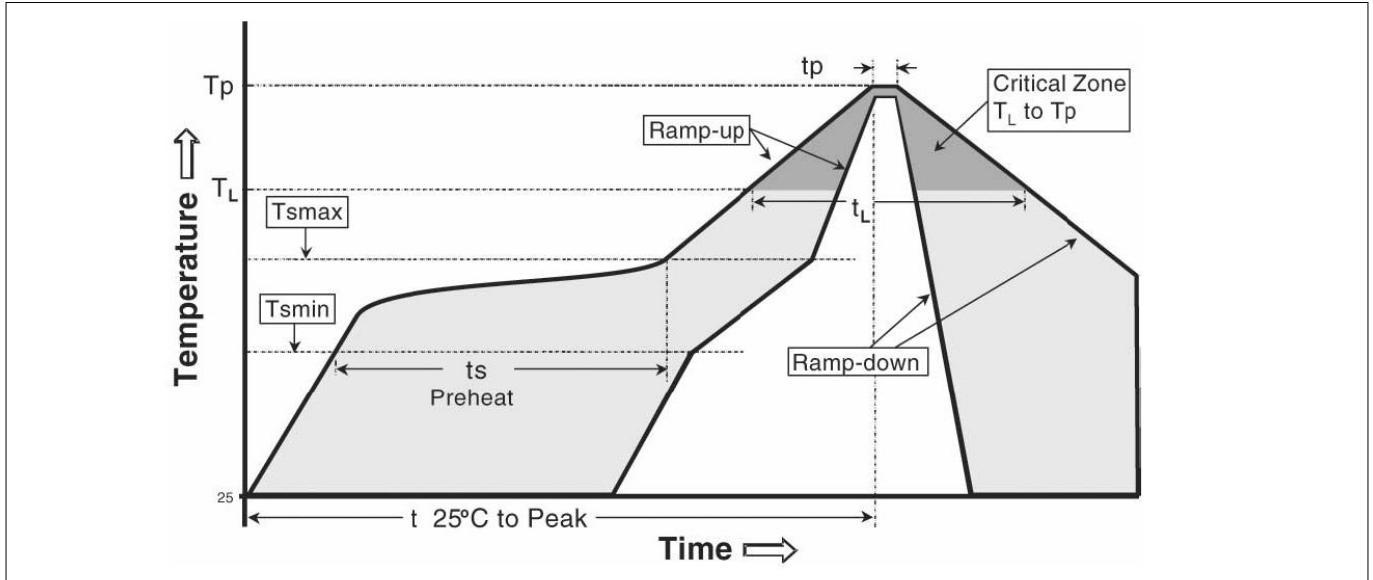

Figure 14 Recommended reflow profile

Table 11 Reflow profile limits

Profile feature	Pb-Free assembly	Sn-Pb Eutectic assembly
Temperature Min (T _{smin})	150 °C	100 °C
Temperature Max (T _{smax})	200 °C	150 °C
Time (T _{smin} to T _{smax}) (t _s)	60-120 seconds	60-120 seconds
Ramp-up rate (T _L to T _p)	3 °C/second max.	3 °C/second max.
Liquidous temperature (T _L)	217 °C	183 °C
Time (t _L) maintained above T _L	60-150 seconds	60-150 seconds
Peak Temperature (T _p)	260°C +0°C/-5°C	235°C +0°C/-5°C
Time within 5°C of actual peak temperature (t _p) ⁵⁾	20-40 seconds	10-30 seconds
Ramp-down rate	6 °C/second max.	6 °C/second max.
Time 25°C to peak temperature	8 minutes max.	6 minutes max.

Note: For further information please consult the 'General recommendation for assembly of Infineon packages' document which is available on the Infineon Technologies [web page](#)

⁵ Tolerance for peak profile temperature (T_p) is defined as a supplier minimum and a user maximum

Reflow soldering and board assembly

The MEMS microphones can be handled using industry standard pick and place equipment. Care should be taken to avoid damage to the microphone structure as follows:

- Do not pick the microphone with vacuum tools which make contact with the microphone acoustic port hole.
- The microphone acoustic port hole should not be exposed to vacuum, this can destroy or damage the MEMS.
- Do not blow air into the microphone acoustic port hole. If an air blow cleaning process is used, the port hole must be sealed to prevent particle contamination.
- It is recommended to perform the PCB assembly in a clean room environment in order to avoid microphone contamination.
- Air blow and ultrasonic cleaning procedures shall not be applied to MEMS Microphones. A no-clean paste is recommended for the assembly to avoid subsequent cleaning steps. The microphone MEMS can be severely damaged by cleaning substances.
- To prevent the blocking or partial blocking of the sound port during PCB assembly, it is recommended to cover the sound port with protective tape during PCB sawing or system assembly.
- Do not use excessive force to place the microphone on the PCB. The use of industry standard pick and place tools is recommended in order to limit the mechanical force exerted on the package.

Reliability specifications

8 Reliability specifications

The microphone sensitivity and SNR after stress must deviate by no more than 3dB from the initial value. All samples are submitted to 3x reflow (260°C peak temperature) before stress

Table 12 Reliability Tests

Test	Test Condition	Standard
Low temperature operation	T _a =-40°C, VDD=2.5V, 1000 hours.	JESD22-A108
Low temperature storage	T _a =-40°C, 1000 hours.	JESD22-A119
High temperature operation	T _a =+125°C, VDD=2.5V, 1000 hours.	JESD22-A108
High temperature storage	T _a =+125°C, 1000 hours.	JESD22-A103
Temperature cycling	1000 cycles, -40°C to +125°C, 30 minutes per cycle.	JESD22-A104
Temperature Humidity bias	T _a =+85°C, R.H = 85%, VDD=2.5V, 1000 hours.	JESD22-A101
Vibration	20Hz to 2000Hz with a peak acceleration of 20g in X, Y, and Z for 4 minutes each, total 4 cycles.	IEC 60068-2-6 / MIL-STD 883K 2007.3
Mechanical shock	10000g/0.1 msec in X, Y, Z direction. 5 shocks in each direction, 30 shocks in total. VDD=2.0V	IEC 60068-2-27
Reflow solder ⁶⁾	3 reflow cycles, peak temperature = +260°C	IPC-JEDEC J-STD-020D-01
ESD-SLT	25 discharges of +/-8kV direct contact to lid while unit is grounded.	IEC-61000-4-2
ESD-CDM	3 discharges of +/-500V direct contact to I/O pins.	JEDEC JS-002-2014
ESD-HBM	3 discharges of ±2kV pin to pin.	JEDEC JS-001-2011

⁶⁾ The microphone sensitivity must deviate by no more than 1dB from the initial value after 3 reflow cycles.

Revision history

Revision history

Document version	Date of release	Description of changes
v01_00	2020-10-27	<ul style="list-style-type: none">Initial datasheet release
v01_10	2022-03-15	<ul style="list-style-type: none">updated Tape and Reel Information

Glossary

Trademarks

All referenced product or service names and trademarks are the property of their respective owners.

Edition 2022-03-15

Published by

Infineon Technologies AG

81726 Munich, Germany

© 2022 Infineon Technologies AG

All Rights Reserved.

Do you have a question about any aspect of this document?

Email: erratum@infineon.com

Document reference

IFX-nnz1570625061557

Important notice

The information given in this document shall in no event be regarded as a guarantee of conditions or characteristics ("Beschaffheitsgarantie").

With respect to any examples, hints or any typical values stated herein and/or any information regarding the application of the product, Infineon Technologies hereby disclaims any and all warranties and liabilities of any kind, including without limitation warranties of non-infringement of intellectual property rights of any third party.

In addition, any information given in this document is subject to customer's compliance with its obligations stated in this document and any applicable legal requirements, norms and standards concerning customer's products and any use of the product of Infineon Technologies in customer's applications.

The data contained in this document is exclusively intended for technically trained staff. It is the responsibility of customer's technical departments to evaluate the suitability of the product for the intended application and the completeness of the product information given in this document with respect to such application.

Warnings

Due to technical requirements products may contain dangerous substances. For information on the types in question please contact your nearest Infineon Technologies office.

Except as otherwise explicitly approved by Infineon Technologies in a written document signed by authorized representatives of Infineon Technologies, Infineon Technologies' products may not be used in any applications where a failure of the product or any consequences of the use thereof can reasonably be expected to result in personal injury.

X-ON Electronics

Largest Supplier of Electrical and Electronic Components

Click to view similar products for [Audio IC Development Tools](#) category:

Click to view products by [Infineon](#) manufacturer:

Other Similar products are found below :

[1580/5171-DEMO](#) [EV_ICS-40740-FX](#) [EVALAUDAMP25TOBO1](#) [KITA2GAUDIOSHIELDTOBO1](#) [KITIM69D127V11FLEXTOBO1](#)
[KITA2GMICARRAYTOBO1](#) [BOB-19389](#) [MIKROE-5721](#) [ESP32-C3-Lyra](#) [BD34352EKV-E2](#) [ESP32-S3-BOX-Lite](#) [SC0368](#) [BOB-21250](#)
[BD34352EKV-EVK-001](#) [BD34301EKV-EVK-003](#) [QC-ACC-AUDIO-OUT](#) [QC-ACC-AUDIO-IN](#) [EV36K06A](#) [DFR0941](#) [8CH-DMIC](#)
[MX93AUD-HAT](#) [PAM8965-EVM](#) [U055-B](#) [TPA3223EVM](#) [EV_T5838-FX2](#) [MD-54001-D58](#) [EVALAUDIOMA12070PBTOBO1](#) [KIT-21230](#)
[EV_T5837-FX2](#) [EVALAHNBANALOGV01TOBO1](#) [ABX00061](#) [1063](#) [TAS5756MDCAEVM](#) [TLV320ADC3101EVM-K](#)
[TLV320AIC3007EVM-K](#) [TLV320AIC3105EVM-K](#) [TLV320AIC3111EVM-K](#) [TLV320AIC3253EVM-K](#) [TLV320DAC32EVM-PDK](#)
[TPA2035D1EVM](#) [TPA2051D3YFFEVM](#) [TPA3107D2EVM](#) [TPA6120A2EVM](#) [TPA6132A2EVM2](#) [MIKROE-2454](#) [ISD5102EY](#) [1381](#)
[DA7217-EVAL](#) [DIX4192EVM-PDK](#) [LM48555TLBD](#)