

KIT_T2G-B-E_LITE user guide

About this document

Scope and purpose

This document serves as a guide for using the KIT_T2G-B-E_LITE. This document explains the kit operation, describes the Sample Driver Library (SDL) and its operation, and the hardware details of the board.

Intended audience

This document is intended for KIT_T2G-B-E_LITE users.

Reference documents

This user guide should be read in conjunction with the following documents:

- [AN220118 - Getting started with TRAVEO™ T2G family MCUs](#)
- [TRAVEO™ T2G Body Entry \(CYT2BL series\) datasheet](#)

Table of contents

Table of contents

About this document..... 1

Table of contents..... 2

Safety and regulatory compliance information 3

General safety instructions 3

1 Introduction 4

1.1 Getting started.....4

1.2 Additional learning resources.....4

1.3 Technical support.....5

1.4 Documentation conventions5

1.5 Abbreviations and definitions.....5

2 Kit details..... 7

2.1 Kit contents7

2.2 Board details7

3 Kit operation13

3.1 Theory of operation.....13

3.2 KitProg3: Onboard programmer/debugger17

3.2.1 Programming and debugging using TRAVEO™ T2G Sample driver library software.....17

3.2.2 USB-UART bridge19

4 Hardware20

4.1 KIT_T2G-B-E_Lite Kit Connections20

4.1.1 USER LEDs20

4.1.2 USER switches20

4.1.3 RESET switch20

4.1.4 MODE switch.....20

4.2 System Configuration21

4.3 Schematics21

4.4 Layouts32

Revision history.....35

Safety and regulatory compliance information

Safety and regulatory compliance information

This kit is intended for development purposes only. Users are advised to test and evaluate this kit in an RF development environment.

Safety evaluation for this kit is done in factory default settings using default accessories shipped with the kit. All evaluations for safety are carried out using a 5-V (USB 2.0, @ 500 mA) supply. Attaching additional wiring to this product or modifying the product operation from the factory default may affect its performance and cause interference with other apparatus in the immediate vicinity. If such interference is detected, suitable mitigating measures should be taken.

This kit is not a finished product and when assembled may not be resold or otherwise marketed unless all required authorizations are first obtained. Contact [Infineon support](#) for details.



These kits contain electrostatic discharge (ESD) sensitive devices. Electrostatic charges readily accumulate on the human body and any equipment, which can cause a discharge without detection. Permanent damage may occur on devices subjected to high-energy discharges. Proper ESD precautions are recommended to avoid performance degradation or loss of functionality. Store unused kits in the protective shipping package.



End-of-life/product recycling

The end-of-life cycle for this kit is five years from the date of manufacture mentioned on the back of the box. Contact your nearest recycler to discard the kit.

General safety instructions

ESD protection

ESD can damage boards and associated components. Infineon recommends that you perform procedures only at an ESD workstation. If an ESD workstation is unavailable, use appropriate ESD protection by wearing an anti-static wrist strap attached to the chassis ground (any unpainted metal surface) on your board when handling parts.

Handling boards

This board is sensitive to ESD. Hold the board only by its edges. After removing the board from its box, place it on a grounded, static-free surface. Use a conductive foam pad, if available. Do not slide the board over any surface.

Introduction

1 Introduction

Thank you for your interest in the KIT_T2G-B-E_LITE. The TRAVEO™ T2G Body Entry Lite evaluation kit enables you to evaluate and develop your applications using the **TRAVEO™ T2G Body Entry MCU** (hereafter called “TRAVEO™ T2G-B-E MCU”).

The TRAVEO™ T2G-B-E MCU is designed for automotive applications and is a true programmable embedded system-on-chip, integrating up to 160-MHz Arm® Cortex®-M4F as the primary application processors, a 100-MHz Arm® Cortex®-M0+ that supports low-power operations, up to 4-MB flash and 512-KB SRAM, and programmable analog and digital peripherals that allow faster time-to-market.

The evaluation board features an on-board programmer/debugger (KitProg3), a micro-B connector for the USB device interface, three user LEDs, one potentiometer, and two push buttons. The board supports operating voltages from 2.7 V to 5.5 V for the TRAVEO™ T2G-B-E MCU.

You can use ModusToolbox™ software to develop and debug your TRAVEO™ T2G-B-E MCU projects. **ModusToolbox™ software** is a set of tools that enable you to integrate these devices into your existing development methodology.

If you are new to TRAVEO™ T2G-B-E MCU and "**Sample Driver Library (SDL)**", refer to the application note **AN220118 - Getting started with TRAVEO™ T2G family MCUs** to help you familiarize with the TRAVEO™ T2G-B-E MCU and help you create your own design using the SDL.

1.1 Getting started

This guide helps you to get acquainted with this evaluation kit:

- The **Kit details** chapter provides the kit and package details and board details.
- The **Kit operation** chapter describes the major features of the TRAVEO™ T2G-B-E evaluation board and functionalities such as programming, debugging, and the USB-UART, and USB-I2C bridges.
- The **Hardware** chapter provides a detailed hardware description, kit schematics, and the bill of materials (BOM).
- The SDL supports application development using the TRAVEO™ T2G-B-E evaluation kit. The SDL simplified software development for TRAVEO™ T2G devices includes the following:
 - Drivers for an extensive set of peripherals.
 - Arm® Cortex® Microcontroller Software Interface Standard (CMSIS) core header files directly from the CMSIS 5.7 release.
 - CMSIS compliant device header files, standup code (platform initialization), and device configuration header files.
 - Application programming interface reference manual.
 - Examples to evaluate various peripherals.
- SDL is provided as an executable, tested on Windows 10 with a minimum installation size requirement of around 400 MB.

1.2 Additional learning resources

Infineon provides a wealth of data at **32-bit TRAVEO™ T2G Arm® Cortex® Microcontroller** to help you to select the right TRAVEO™ T2G MCU device for your design and to help you quickly and effectively integrate the device into your design.

Introduction

1.3 Technical support

For assistance, go to www.infineon.com/support. Visit community.infineon.com to ask your questions in Infineon developer community.

You can also use the following support resources if you need quick assistance:

- [Self-help \(Technical documents\)](#)

1.4 Documentation conventions

Table 1 Document conventions for guides

Convention	Usage
Courier New	Displays user-entered text and source code
<i>Italics</i>	Displays file names and reference documentation: Read about the <i>sourcefile.hex</i> file in the <i>PSoC™ Creator user guide</i> .
File > Open	Represents menu paths: File > Open > New Project
Bold	Displays commands, menu paths, and icon names in procedures: Click the File icon and then click Open .
Times New Roman	Displays an equation: $2 + 2 = 4$
Text in gray boxes	Describes Cautions or unique functionality of the product.

1.5 Abbreviations and definitions

Table 2 Abbreviations

Abbreviation	Definition
ADC	analog-to-digital converter
BOM	bill of materials
CINT	Integration Capacitor
CMOD	Modulator Capacitor
CPU	central processing unit
CSD	capacitive sigma delta
CSX	CAPSENSE™ Crosspoint
CTANK	Shield Tank Capacitor
DC	direct current
ECO	external crystal oscillator
ESD	electrostatic discharge
FPC	flexible printed circuit
GPIO	general-purpose input/output
IC	integrated circuit
IDE	integrated development environment
IoT	Internet of Things

Introduction

Abbreviation	Definition
I2C	inter-integrated circuit
I2S	Inter-IC Sound
LED	light-emitting diode
LPO	low power oscillator
PC	personal computer
PDL	peripheral driver library
QSPI	Quad serial peripheral interface
SDHC	Secure Digital Host Controller
SDIO	Secure Digital Input Output
SDK	software development kit
SMIF	Serial Memory Interface
SPI	Serial Peripheral Interface
SRAM	static random-access memory
SWD	Serial Wire Debug
UART	universal asynchronous receiver transmitter
USB	Universal Serial Bus
WCO	watch crystal oscillator

Kit details

2 Kit details

2.1 Kit contents

- KIT_T2G-B-E_LITE board

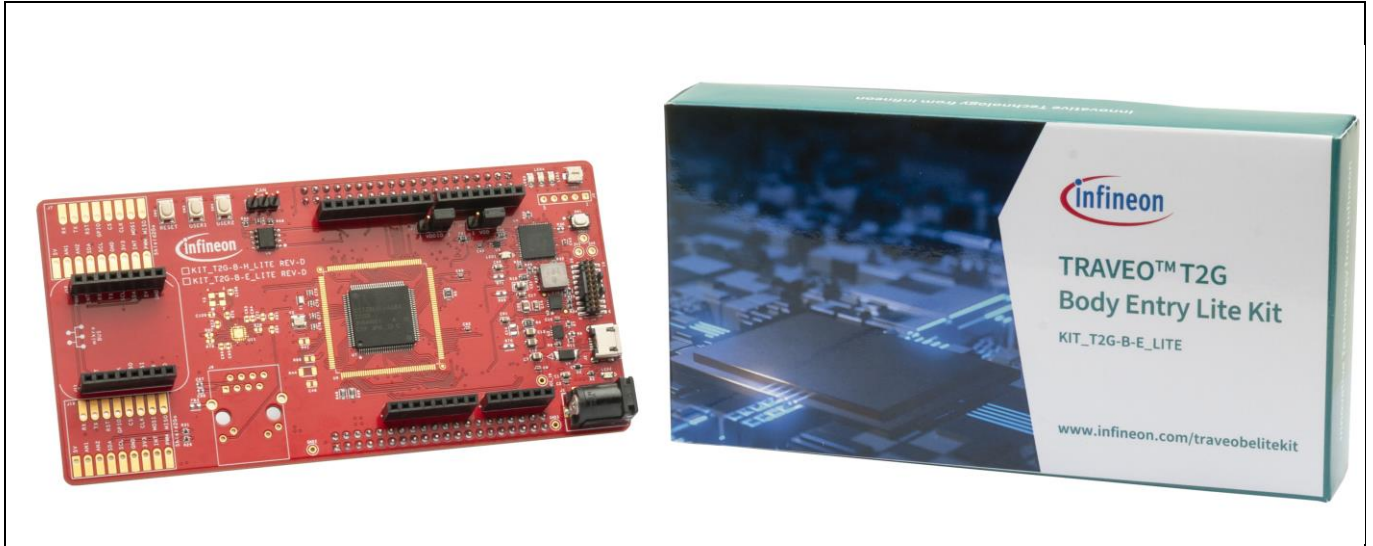

Figure 1 Kit contents

Inspect the contents of the kit; if you find any part missing, go to <https://www.infineon.com/cms/en/product/microcontroller/32-bit-traveo-t2g-arm-cortex-microcontroller/32-bit-traveo-t2g-arm-cortex-for-body/traveo-t2g-cyt2bl-series>.

2.2 Board details

The KIT_T2G-B-E_LITE has the following features:

- TRAVEO™ T2G-B-E MCU. See the device [datasheet](#).
- KitProg3 on-board SWD programmer/debugger, USB-UART, and USB-I2C bridge functionality.
- A micro-B connector for USB device interface
- Selectable input supply voltages of 3.3 V and 5.0 V for the TRAVEO™ T2G-B-E MCU.
- Three user LEDs, two user buttons, and a reset button for the TRAVEO™ T2G-B-E MCU
- A potentiometer which can be used to simulate analog sensor output
- A mode button and a mode LED for KitProg3

Kit details

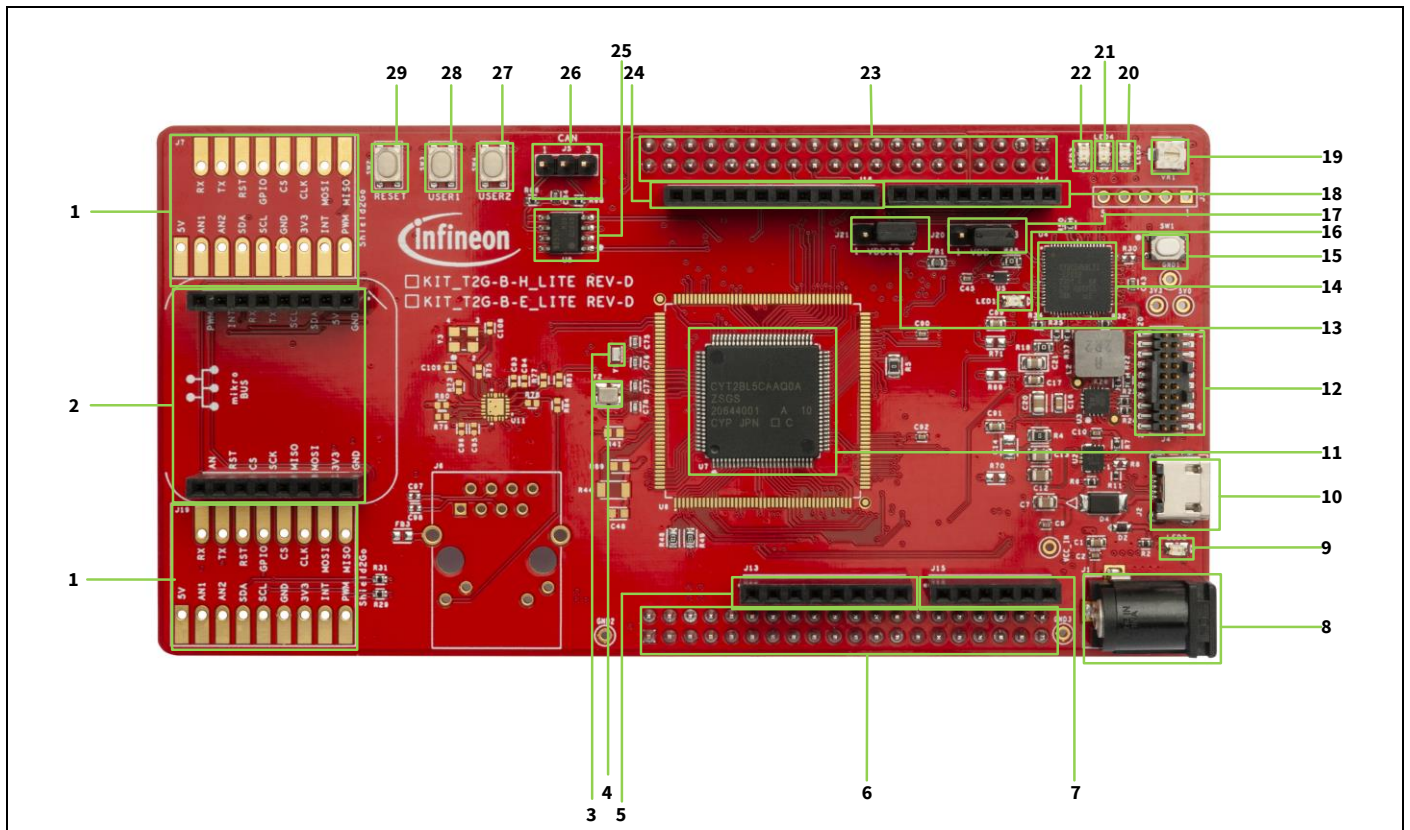

Figure 2 KIT_T2G-B-E_LITE board – top view

1. Shield2Go connectors (Not Mounted) (J7, J19)
2. MikroBUS connectors (J11, J12)
3. 32.768-kHz oscillator for WCO (Y1)
4. 16-MHz oscillator for ECO (Y2)
5. 8-pin Arduino header (J13)
6. Expansion header 1 (X1)
7. 6-pin Arduino header (J15)
8. DC Power Jack (J1)
9. Power LED (LED2)
10. KitProg3 USB Micro-B Connector (J2)
11. TRAVEO™ T2G microcontroller (U7)
12. MIPI10/20 DEBUG connector (J4)
13. VDDIO current measurement jumper (J21)
14. PSoC™ 5LP based KitProg3 (U4)
15. Mode switch (SW1)
16. KitProg3 Status LED (LED1)
17. VDD current measurement jumper (J20)
18. 8-pin Arduino header (J14)
19. Potentiometer (VR1)
20. USER LED3 (LED5)
21. USER LED2 (LED4)

Kit details

- 22. USER LED1 (LED3)
- 23. Expansion Header 2 (X2)
- 24. 10-pin Arduino header (J16)
- 25. CAN FD transceiver (U8)
- 26. CAN FD connector (J5)
- 27. USER2 button (SW4)
- 28. USER1 button (SW3)
- 29. RESET button (SW2)

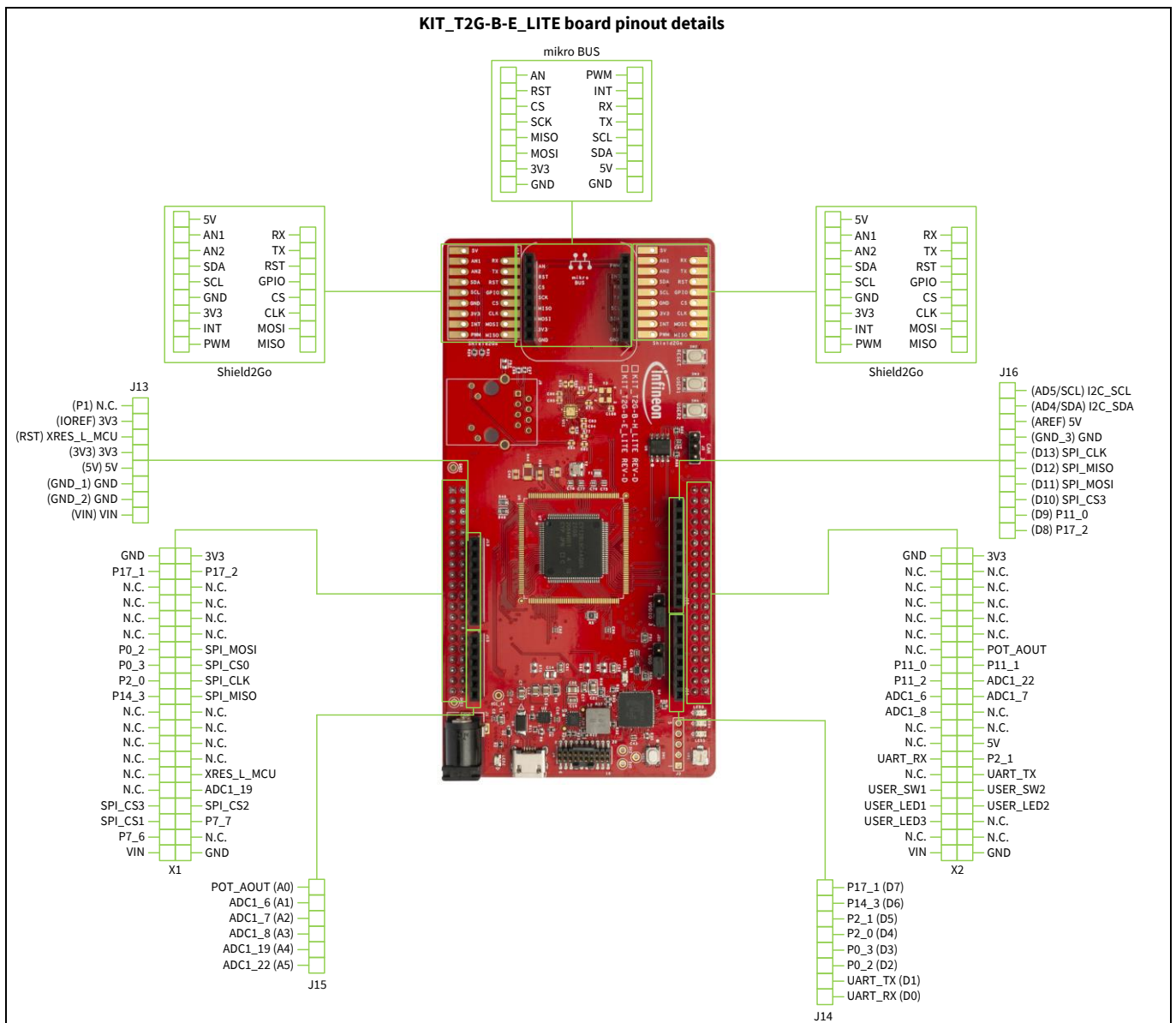

Figure 3 KIT_T2G-B-E_LITE board pinout

Kit details

Table 3 KIT_T2G-B-E_LITE board pinout

Pin	Primary onboard function	Secondary onboard function	Connection details
TRAVEO™ T2G-B-E MCU pins			
XRES	Hardware reset	–	
P12[0]	CAN transmit CAN_TX	–	Connected to TxD of CAN FD transceiver TLE9251VSJ
P12[1]	CAN receive CAN_RX	–	Connected to RxD of CAN FD transceiver TLE9251VSJ
P6[0]	Potentiometer (POT) output POT_AOUT	Arduino header (J15.1)	–
P13[0]	D12 – header compatible with Arduino (J16.5)	Expansion header (X1.20)	–
P13[1]	D11 – header compatible with Arduino (J16.4)	Expansion header (X1.14)	–
P13[2]	D13 – header compatible with Arduino (J16.6)	Expansion header (X1.18)	–
P13[6]	D10 – header compatible with Arduino (J16.3)	Expansion header (X1.33)	–
P11[0]	D9 – header compatible with Arduino (J16.2)	Shield2Go Connector (J7.12) Expansion header (X2.26)	–
P17[2]	D8 – header compatible with Arduino (J16.1)	Shield2Go Connector (J19.13) Expansion header (X1.4)	–
P14[0]	UART_RX	Shield2Go Connector (J7.10, J19.10) MikroBUS Connector (J12.6)	This pin is connected to the KitProg3 UART Tx pin.
P14[1]	UART_TX	Pin D1 of connector J4.2 compatible with Arduino Shield2Go Connector (J7.11, J19.11) MikroBUS Connector (J12.5)	This pin is connected to the KitProg3 UART Rx pin. Remove R132 and R142, and install R136 to connect to Pin D1 of connector J4.2 compatible with Arduino.
P0[2]	Pin D2 of connector J14.3 compatible with Arduino	–	–
P0[3]	Pin D3 of connector J14.4 compatible with Arduino	–	–

Kit details

Pin	Primary onboard function	Secondary onboard function	Connection details
P2[0]	Pin D4 of connector J14.5 compatible with Arduino	-	-
P2[1]	Pin D5 of connector J14.6 compatible with Arduino	-	-
P14[3]	Pin D6 of connector J14.7 compatible with Arduino	-	-
P17[1]	Pin D7 of connector J14.8 compatible with Arduino	-	-
P12[2]	A1 – header compatible with Arduino (J15.2)	-	-
P12[3]	A2 – header compatible with Arduino (J15.3)	-	-
P12[4]	A3 – header compatible with Arduino (J15.4)	-	-
P13[7]	A4 – header compatible with Arduino (J15.5)	-	-
P14[2]	A5 – header compatible with Arduino (J15.6)	-	-
P6[1]	I2C SDA - Common I2C SDA pin for KitProg3 USB-I2C bridge	I2C SDA pin Arduino header (J16.9)	-
P6[2]	I2C SCL - Common I2C SCL pin for KitProg3 USB-I2C bridge	I2C SCL pin on Arduino header (J16.10)	-
P5[0]	USER LED1 (LED1)	ExpansionConnector (X2.8)	-
P5[1]	USER LED2 (LED2)	ExpansionConnector (X2.7)	-
P5[2]	USER LED3 (LED3)	ExpansionConnector (X2.6)	-
P5[3]	User button (USER BUTTON1)	Expansion Connector (X2.10)	-
P17[0]	User button (USER BUTTON2)	Expansion Connector (X2.9)	-
P21[0]	WCO IN (Y1)	-	32.768-kHz watch crystal oscillator input
P21[1]	WCO OUT (Y1)	-	32.768-kHz watch crystal oscillator output
P21[2]	ECO IN (Y2)	-	16-MHz external crystal oscillator input
P21[3]	ECO OUT (Y2)	-	16-MHz external crystal oscillator input
P23[4]	SWO_TDO	DEBUG MIPI 10/20 Connector (J4.6)	-

Kit details

Pin	Primary onboard function	Secondary onboard function	Connection details
P23[5]	SWCLK_TCLK	DEBUG MIPI 10/20 Connector (J4.4)	-
P23[6]	SWDIO_TMS	DEBUG MIPI 10/20 Connector (J4.2)	-
P23[7]	SWDOE_TDI	DEBUG MIPI 10/20 Connector (J4.8)	-
P18[3]	TRACE_CLK	DEBUG MIPI 10/20 Connector (J4.12)	-
P18[4]	TRACE_DATA0	DEBUG MIPI 10/20 Connector (J4.14)	-
P18[5]	TRACE_DATA1	DEBUG MIPI 10/20 Connector (J4.16)	-
P18[6]	TRACE_DATA2	DEBUG MIPI 10/20 Connector (J4.18)	-
P18[7]	TRACE_DATA3	DEBUG MIPI 10/20 Connector (J4.20)	-

Kit operation

3 Kit operation

3.1 Theory of operation

The TRAVEO™ T2G-B-E evaluation board is built around TRAVEO™ T2G-B-E MCU. For details of device features, see the device [datasheet](#).

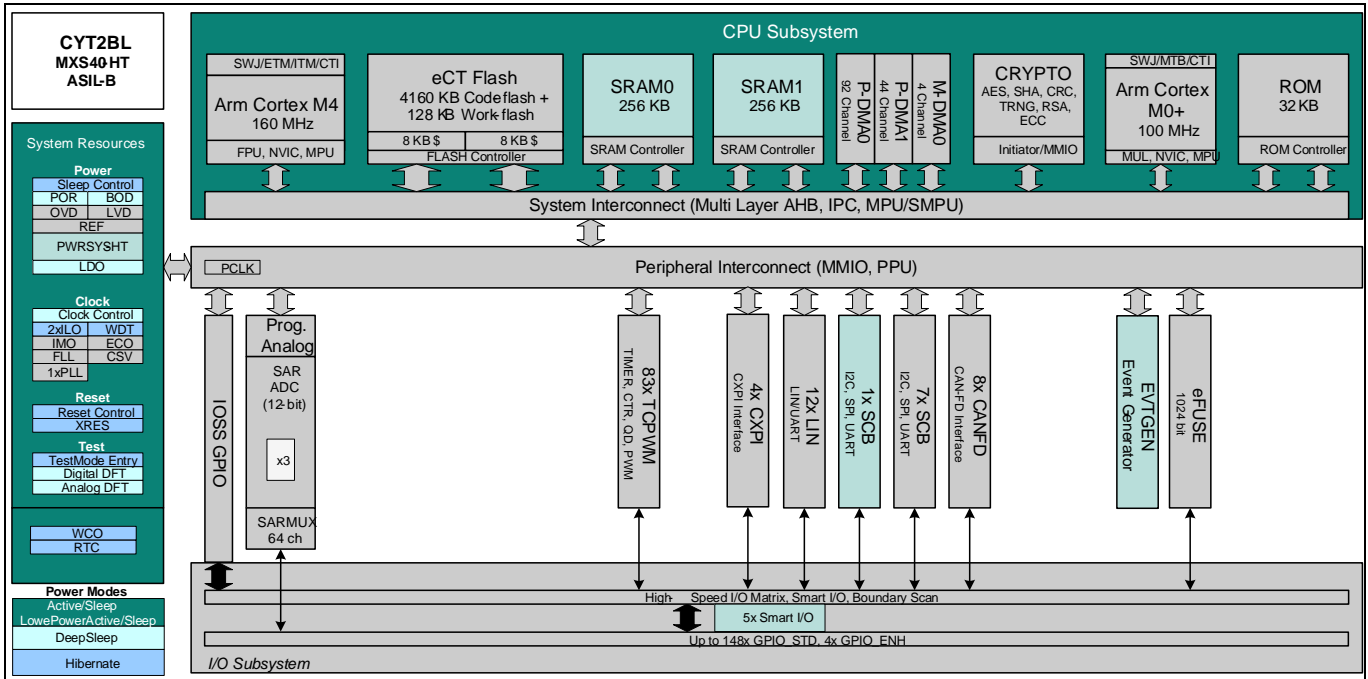

Figure 4 TRAVEO™ T2G-B-E MCU block diagram

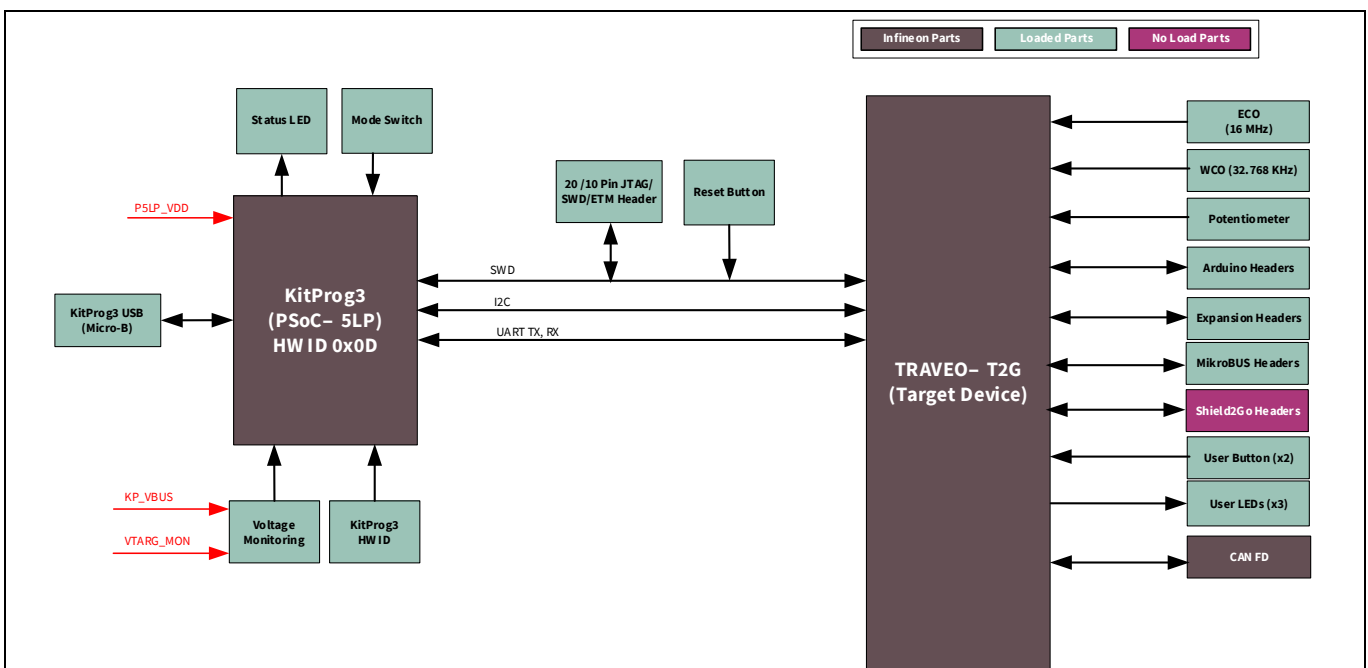

Figure 5 Block diagram of KIT_T2G-B-E_LITE evaluation kit

Kit operation

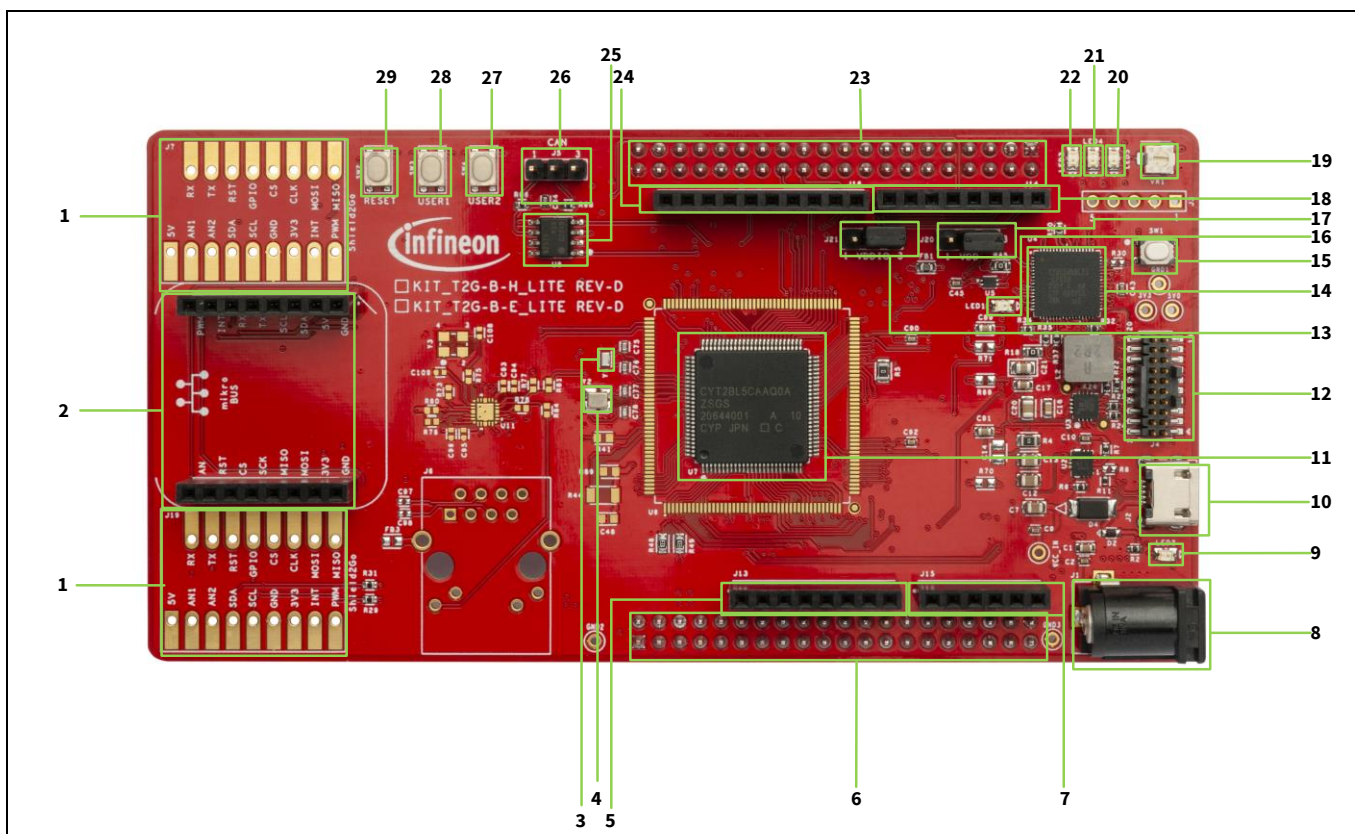

Figure 6 KIT_T2G-B-E_LITE board – top view

The KIT_T2G-B-E_LITE board has the following peripherals:

Table 4 Peripheral details

Sl. No.	Peripheral	Description
1.	Shield2Go Connector	Option connector for Shield2Go Interface (DNI)
2.	MikroBUS Connector	Option connector for MikroBUS Interface (DNI)
3.	32.768 kHz crystal for WCO (Y1)	Oscillator for WCO clock.
4.	16 MHz crystal for ECO (Y2)	Oscillator for ECO clock.
5.	Digital I/O headers compatible with Arduino Uno R3 (J13)	Bring out pins from the TRAVEO™ T2G-B-E MCU to the interface with shields compatible with Arduino. Some of these pins are multiplexed with onboard peripherals and are not connected to TRAVEO™ T2G-B-E MCU by default. For detailed information on how to rework the kit to access these pins, see Table 3 .
6.	Expansion Headers (X1)	These headers provide connectivity to the TRAVEO™ T2G-B-E MCU GPIOs that are not connected to the other onboard functions.
7.	Analog-IN header compatible with Arduino Uno R3 (J15)	Bring out pins from TRAVEO™ T2G-B-E MCU to interface with shields compatible with Arduino. Some of these pins are multiplexed with onboard peripherals and are not connected to TRAVEO™ T2G-B-E MCU by default. For detailed information on how to rework the kit to access these pins, see Table 3 .

Kit operation

Sl. No.	Peripheral	Description
8.	External power supply VIN connector (J1)	Connect to external 12 V/3 A DC power adapter.
9.	Power LED (LED2)	Power supply ON/OFF LED status indicator.
10.	KitProg3 USB connector (J2)	Connect to a PC to use the KitProg3 onboard programmer and debugger and to provide power to the board.
11.	T2G-B-E microcontroller (U7)	TRAVEO™ T2G MCU device used on the kit.
12.	DEBUG MIPI 10/20 connector (J4)	Connect to an Embedded Trace Macrocell (ETM)-compatible programmer/debugger. This is not loaded by default.
13.	T2G-B-E VDDIO current measurement jumper (J21)	J12 connects MCU VDDIO2 to T2G-B-E_VDD which is the outcome of J10 (VCC_3V3 or VCC_5V0) power supply selection.
14.	KitProg3 (PSoC™ 5LP) programmer and debugger (CY8C5868LTI-LP039, U4)	The PSoC™ 5LP device (CY8C5868LTI-LP039) serving as KitProg3, is a multi-functional system, which includes an SWD programmer, debugger, USB-I2C bridge, and USB-UART bridge. For more details, see the KitProg3 user guide .
15.	KitProg3 programming mode selection button (SW1)	Use this button to switch between various modes of operation of KitProg3. Note that this board supports only CMSIS-DAP BULK mode. For more details, see the KitProg3 user guide . This button function is reserved for future use.
16.	KitProg3 status LED (LED1)	Amber LED (LED1) indicates the status of KitProg3. For details on the KitProg3 status, see the KitProg3 user guide .
17.	T2G-B-E VDD current measurement jumper (J20)	J12 connects MCU VDDIO2 to T2G-B-E_VDD which is the outcome of J10 (VCC_3V3 or VCC_5V0) power supply selection.
18.	Power header compatible with Arduino Uno R3 (J14)	Powers the shields compatible with Arduino. It also has a provision to power the kit through the VIN input.
19.	Potentiometer (VR1)	10-kΩ potentiometer connected to TRAVEO™ T2G-B-E MCU pin P6[0]. It can be used to simulate a sensor output to TRAVEO™ T2G-B-E MCU.
20.	User LEDs (LED5)	The user LEDs can operate at the entire operating voltage range of the TRAVEO™ T2G-B-E MCU. The LEDs are active LOW, so the pins must be driven to the ground to turn ON the LEDs.
21.	User LEDs (LED4)	The user LEDs can operate at the entire operating voltage range of the TRAVEO™ T2G-B-E MCU. The LEDs are active LOW, so the pins must be driven to the ground to turn ON the LEDs.
22.	User LEDs (LED3)	The user LEDs can operate at the entire operating voltage range of the TRAVEO™ T2G-B-E MCU. The LEDs are active LOW, so the pins must be driven to the ground to turn ON the LEDs.
23.	Expansion Headers (X2)	These headers provide connectivity to TRAVEO™ T2G-B-E MCU GPIOs that are not connected to the other onboard functions.
24.	Digital I/O headers compatible with Arduino Uno R3 (J16)	Bring out pins from TRAVEO™ T2G-B-E MCU to interface with shields compatible with Arduino. Some of these pins are multiplexed with onboard peripherals and are not connected to TRAVEO™ T2G-B-E MCU by default. For detailed information on how to rework the kit to access these pins, see 0 .
25.	CAN FD transceiver (U8)	CAN FD transceiver.

Kit operation

Sl. No.	Peripheral	Description
26.	CAN FD interface connector (J5)	Connector to connect the kit to the CAN / CAN FD network
27.	User buttons (SW4)	Provide input to TRAVEO™ T2G-B-E MCU. Note that by default the button connects the TRAVEO™ T2G-B-E MCU pin to the ground when pressed, so you need to configure the TRAVEO™ T2G-B-E MCU pin as a digital input with resistive pull-up for detecting the button press.
28.	User buttons (SW3)	Provide input to TRAVEO™ T2G-B-E MCU. Note that by default the button connects the TRAVEO™ T2G-B-E MCU pin to the ground when pressed, so you need to configure the TRAVEO™ T2G-B-E MCU pin as a digital input with resistive pull-up for detecting the button press.
29.	T2G-B-E reset button (SW2)	Resets TRAVEO™ T2G-B-E MCU. It connects the TRAVEO™ T2G-B-E MCU reset (XRES) pin to the ground.

See [0](#)

Layouts for details on various hardware blocks.

Kit operation

3.2 KitProg3: Onboard programmer/debugger

The TRAVEO™ T2G-B-E evaluation kit can be programmed and debugged using the onboard KitProg3. KitProg3 is an onboard programmer/debugger with USB-UART, USB-I2C, and USB-SPI Bridge (not supported on this board) functionality. KitProg3 supports CMSIS-DAP only and does not support mass storage. A PSoC™ 5LP device is used to implement the KitProg3 functionality. For more details on the KitProg3 functionality, see the [KitProg3 user guide](#).

3.2.1 Programming and debugging using TRAVEO™ T2G Sample driver library software

1. Connect the board to the PC using the provided USB cable through the KitProg3 USB connector, as shown in [Figure 7](#). It enumerates as a USB Composite Device if you are connecting it to your PC for the first time.
2. KitProg3 on this kit supports CMSIS-DAP Bulk mode (default) and CMSIS-DAP Bulk with two UARTs. The status LED (amber) is always ON in the CMSIS-DAP Bulk mode. If you do not see the desired LED status, see the [KitProg3 user guide](#) for details on the KitProg3 status and troubleshooting instructions.

Note: The programming can be done in either of the KitProg3 programming modes, but it is recommended to program the kit in CMSIS-DAP Bulk mode.

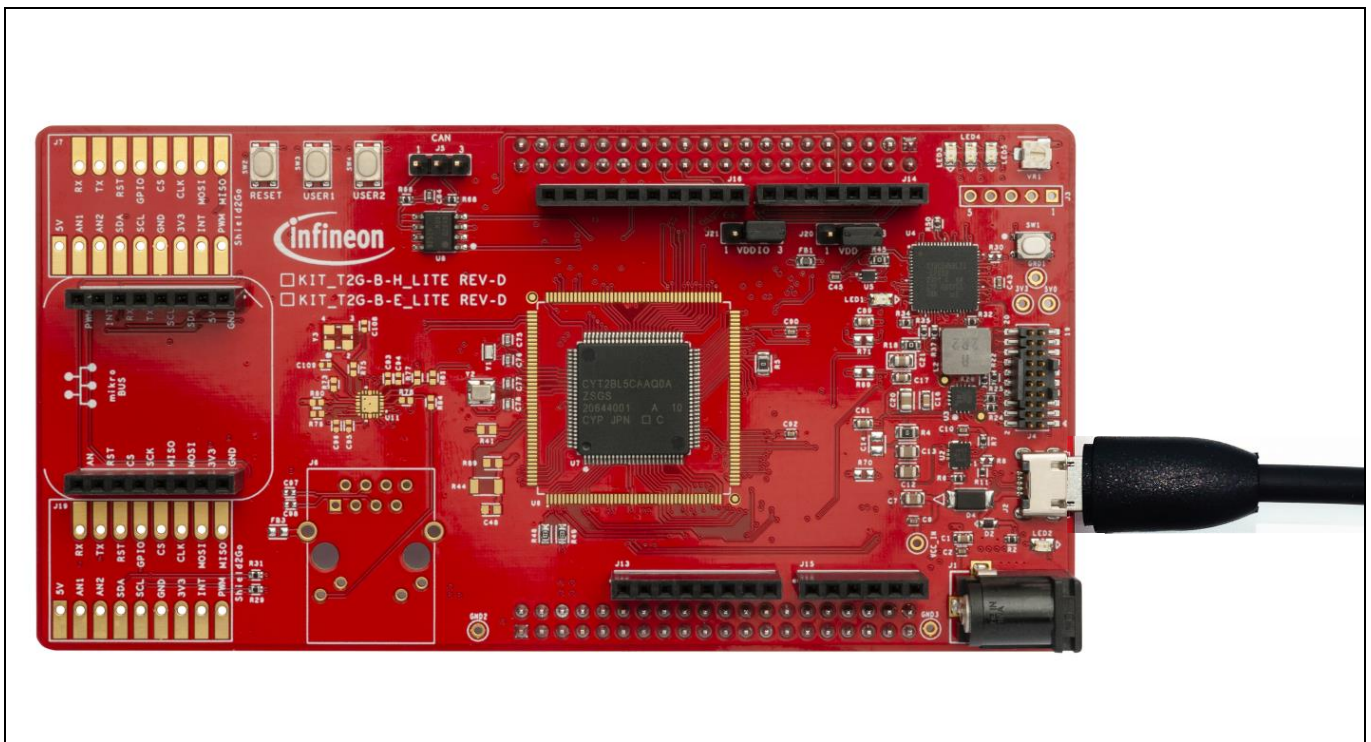

Figure 7 Connect USB cable to USB connector on the board

3.
 - a) Open the IAR EWARM debugger and import the desired code example (application) from the SDL into a new workspace. For example, to open the IAR tool EWARM workspace.

Kit operation

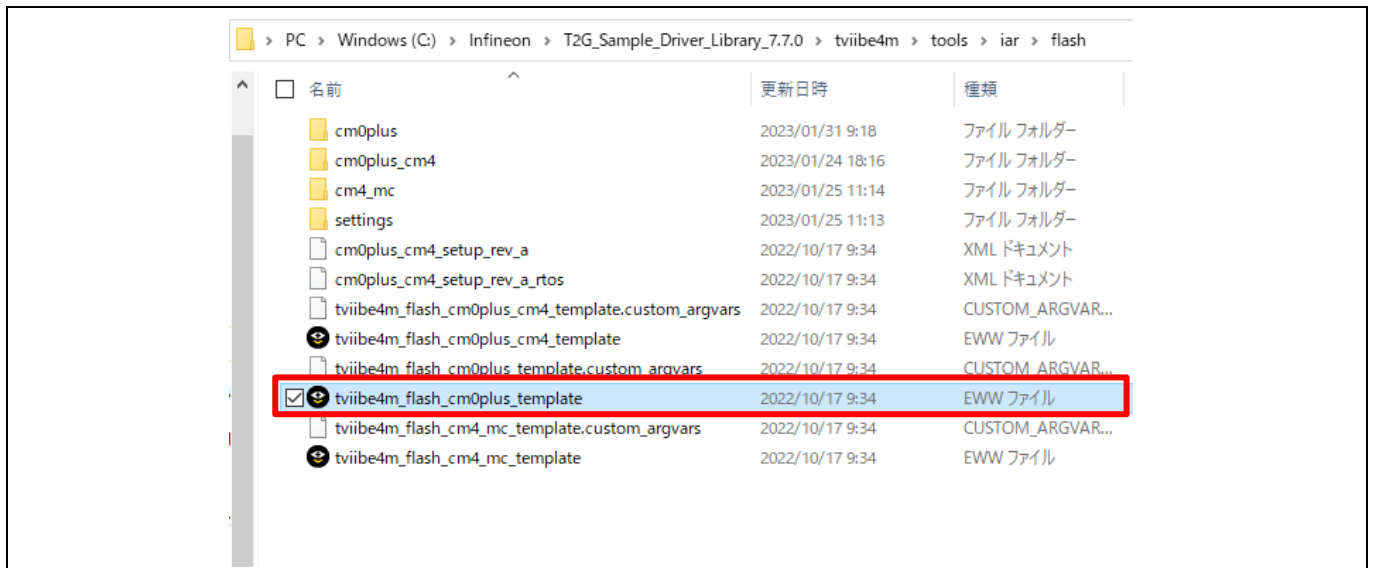

Figure 8 Open Sample Driver Library

b) Select **Make icon** and execute. If compiling succeeds, then select download and debug and execute. Confirm the debug execution.

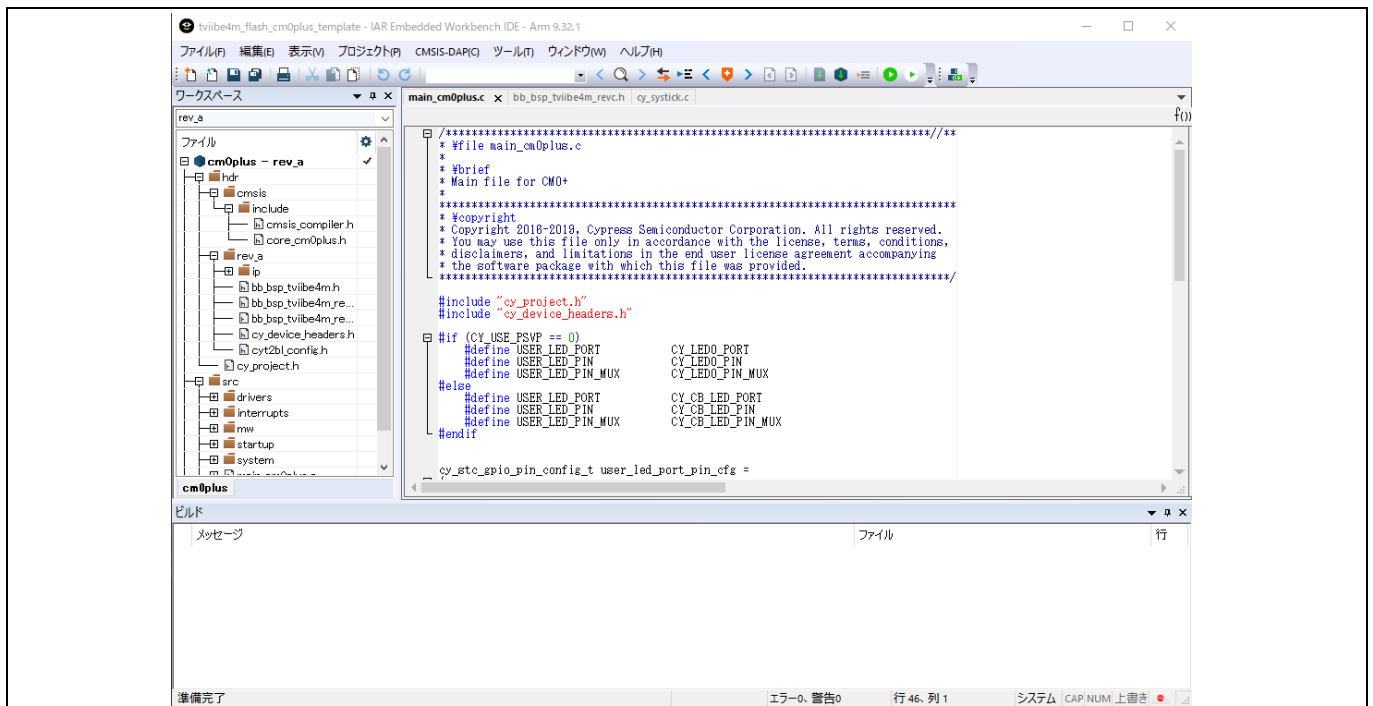

Figure 9 Open Sample Driver Library using IAR EWARM

Kit operation

3.2.2 USB-UART bridge

KitProg3 on the TRAVEO™ T2G-B-E evaluation board can act as a USB-UART bridge.

The UART Rx and Tx pins of KitProg3 are connected to the TRAVEO™ T2G-B-E MCU UART pins as follows:

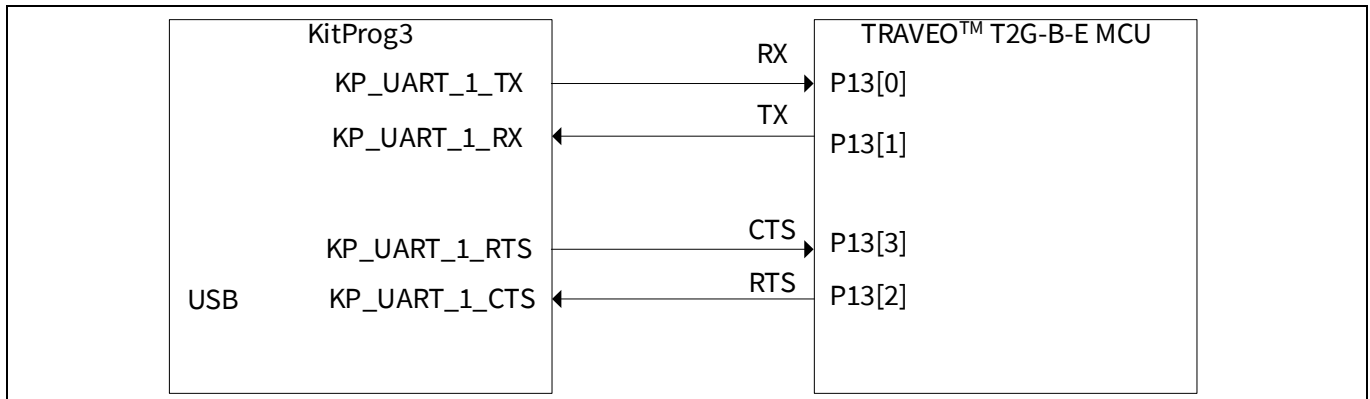

Figure 10 UART connection between KitProg3 and TRAVEO™ T2G-B-E MCU

Hardware

4 Hardware

4.1 KIT_T2G-B-E_Lite kit connections

4.1.1 USER LEDs

The correspondence between the LEDs on the board and the CYT2BL5xx device pins and the port pins are shown in [Table 5](#).

Table 5 USER LEDs

USER LED	Ref. designator	CYT2BL5xx	
		Pin	Pin
USER LED 1	LED3	14	P5.0
USER LED 2	LED4	15	P5.1
USER LED 3	LED5	16	P5.2

4.1.2 USER switches

The correspondence between the switches and the CYT4BF8xx device pins and the port pins are shown in [Table 6](#).

Table 6 USER switches

USER switch	Ref. Designator	CYT2BL5xx	
		Pin	Pin
USER SW 1	SW3	17	P5.3
USER SW 2	SW4	64	P17.0

4.1.3 RESET switch

The correspondence between the RESET switch and the CYT2BL5xx device pin and the port pin are shown in [Table 7](#).

Table 7 RESET switch

USER switch	Ref. designator	CYT2BL5xx	
		Pin	Pin
RESET SW	SW2	85	XRES

4.1.4 MODE switch

The mode switch will change the mode of operation of the KitProg3 device. While communicating with the TRAVEO™ T2G device, make sure that the KitProg3 device should be in CMSIS DAP mode (LED1 is solid ON).

The correspondence between the MODE SW and the PSoC™ 5LP pin number is given in [0](#).

Hardware

Table 8 **MODE switch**

USER switch	Ref. Designator	PSoC 5LP	
		Pin	Pin
MODE SW	SW1	13	P1[2]

4.2 System configuration

Install the KitProg3 USB-UART driver to work with starter kit [KitProg3 User Guide](#). For software and tool configuration, see [TRAVEO T2G Body Entry Lite Kit - Getting Started](#).

4.3 Schematics

This section shows the schematics of the TRAVEO T2G Body Entry Lite Kit Rev D

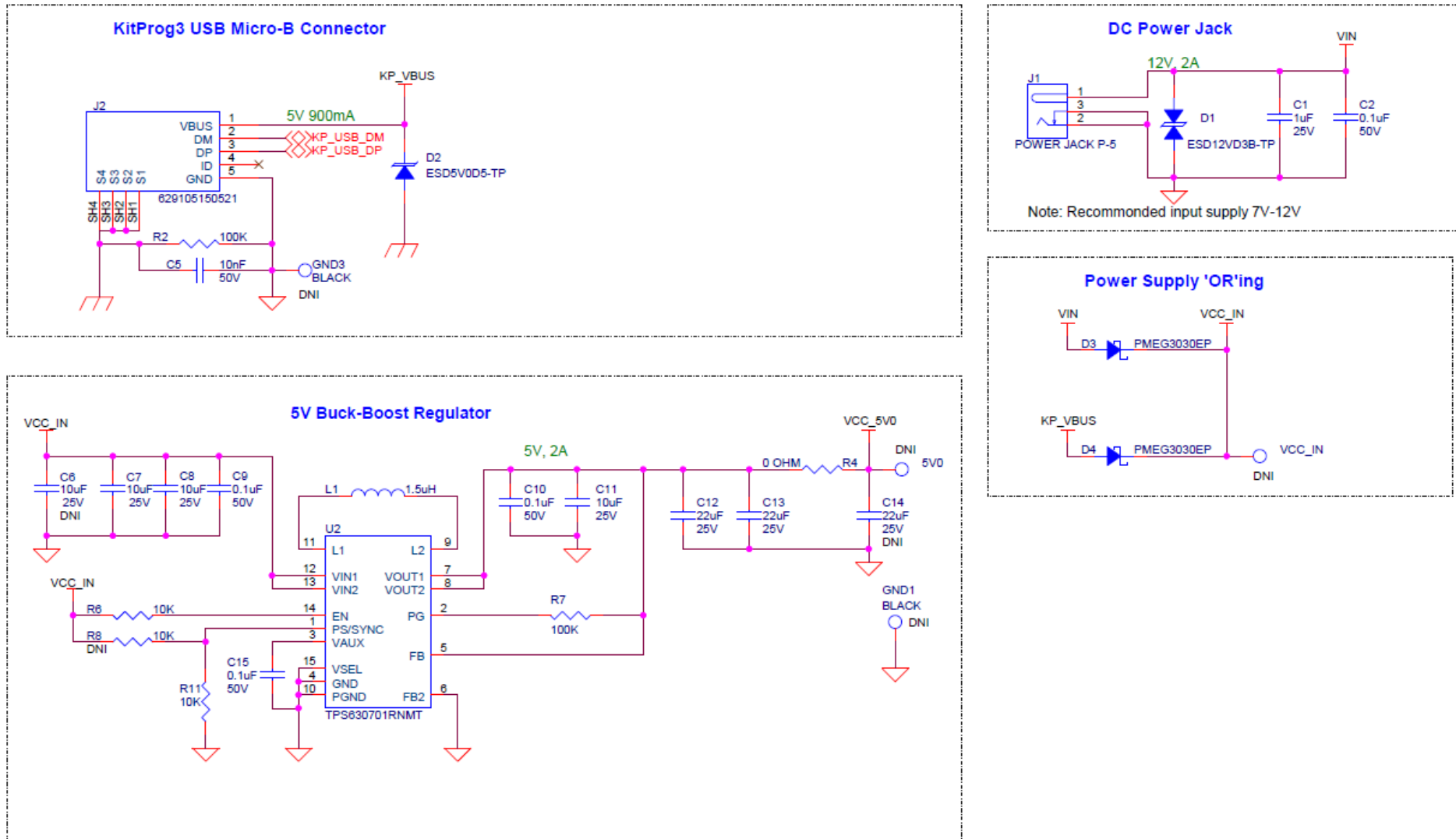

Figure 11 Power supply - 1

General safety instructions

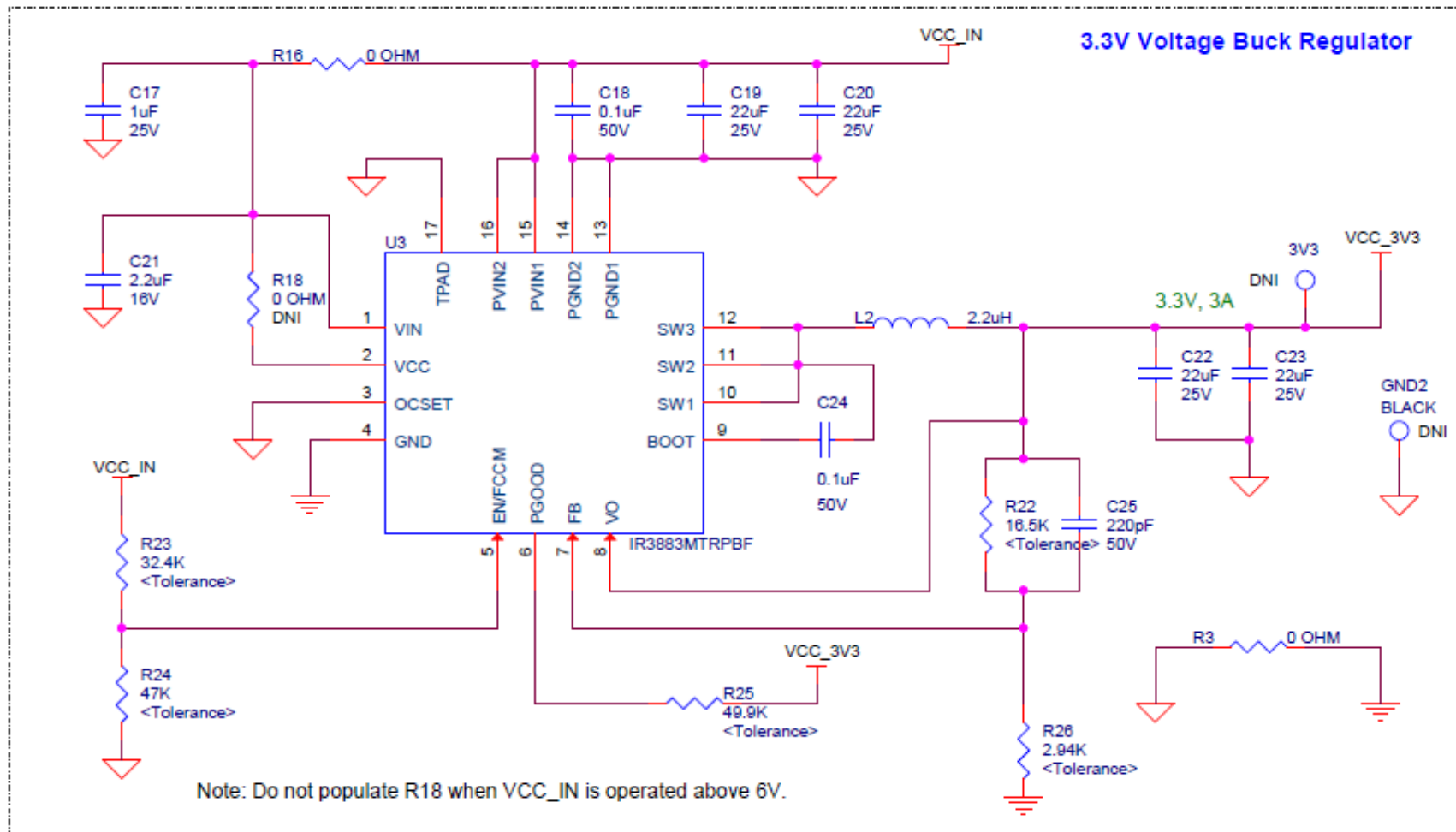

Figure 12 Power supply - 2

General safety instructions

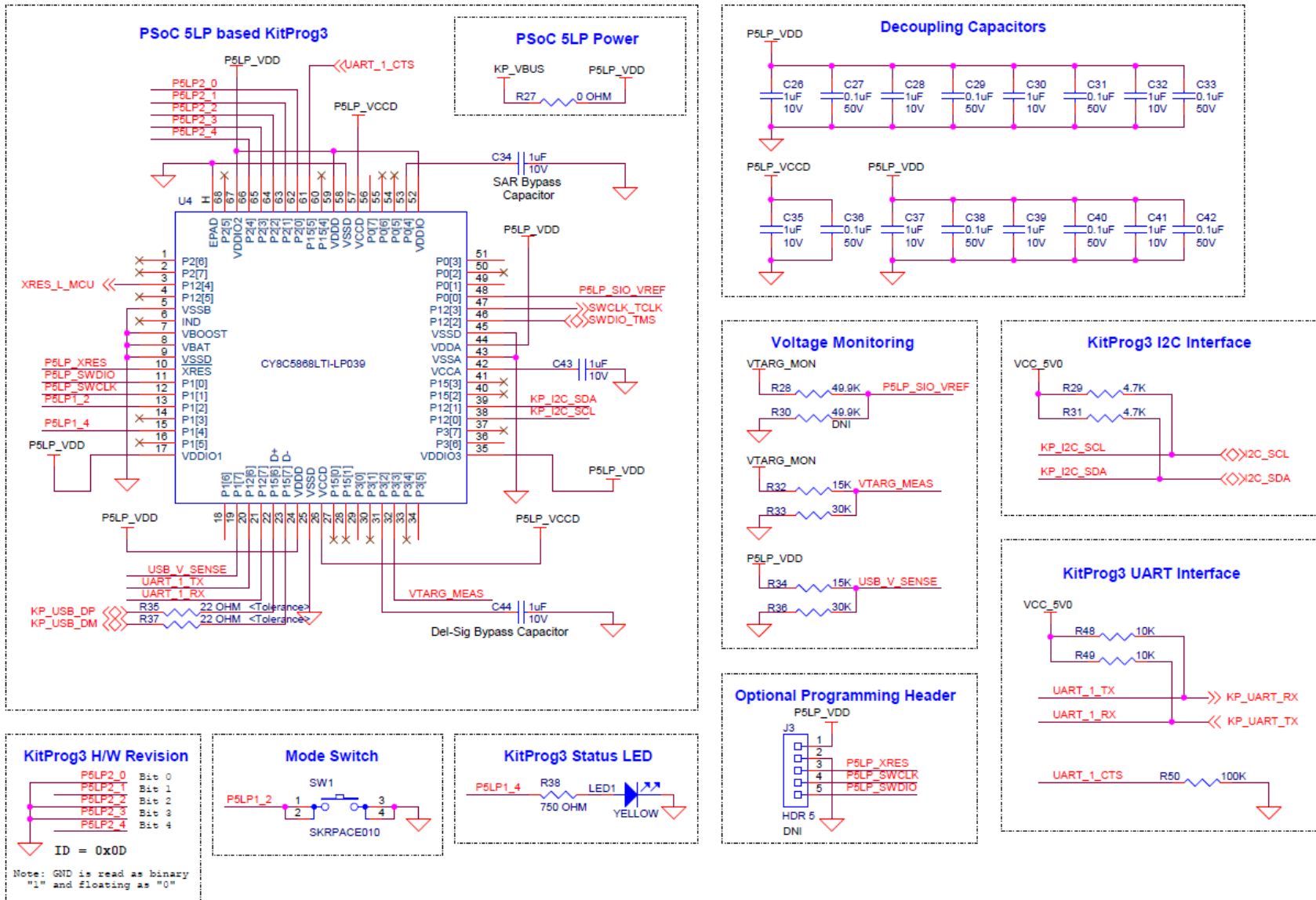

Figure 13 KitProg3 Interface

General safety instructions

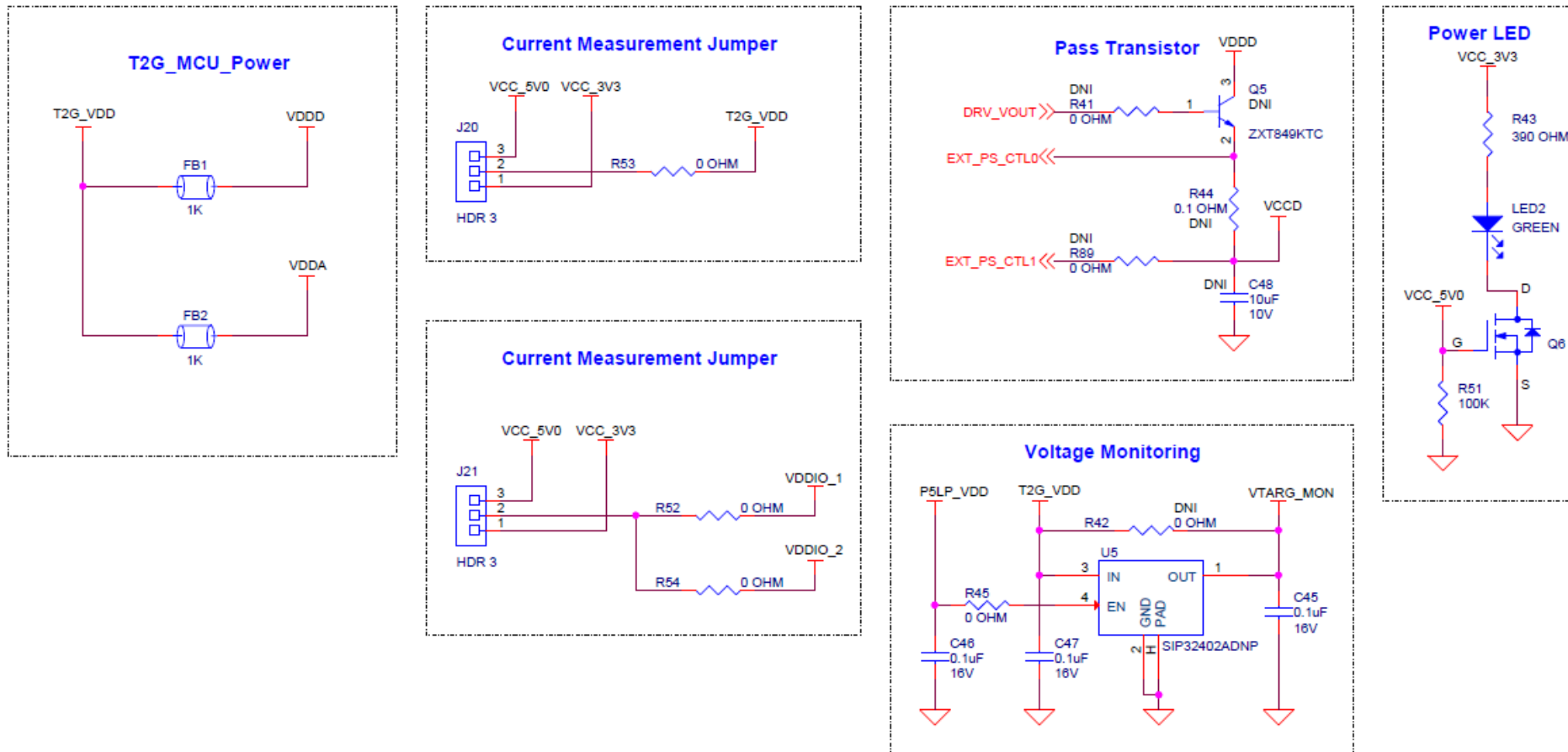

Figure 14 TRAVEO™ T2G MCU Power

General safety instructions

T2G-B-E-4M 100 MCU1

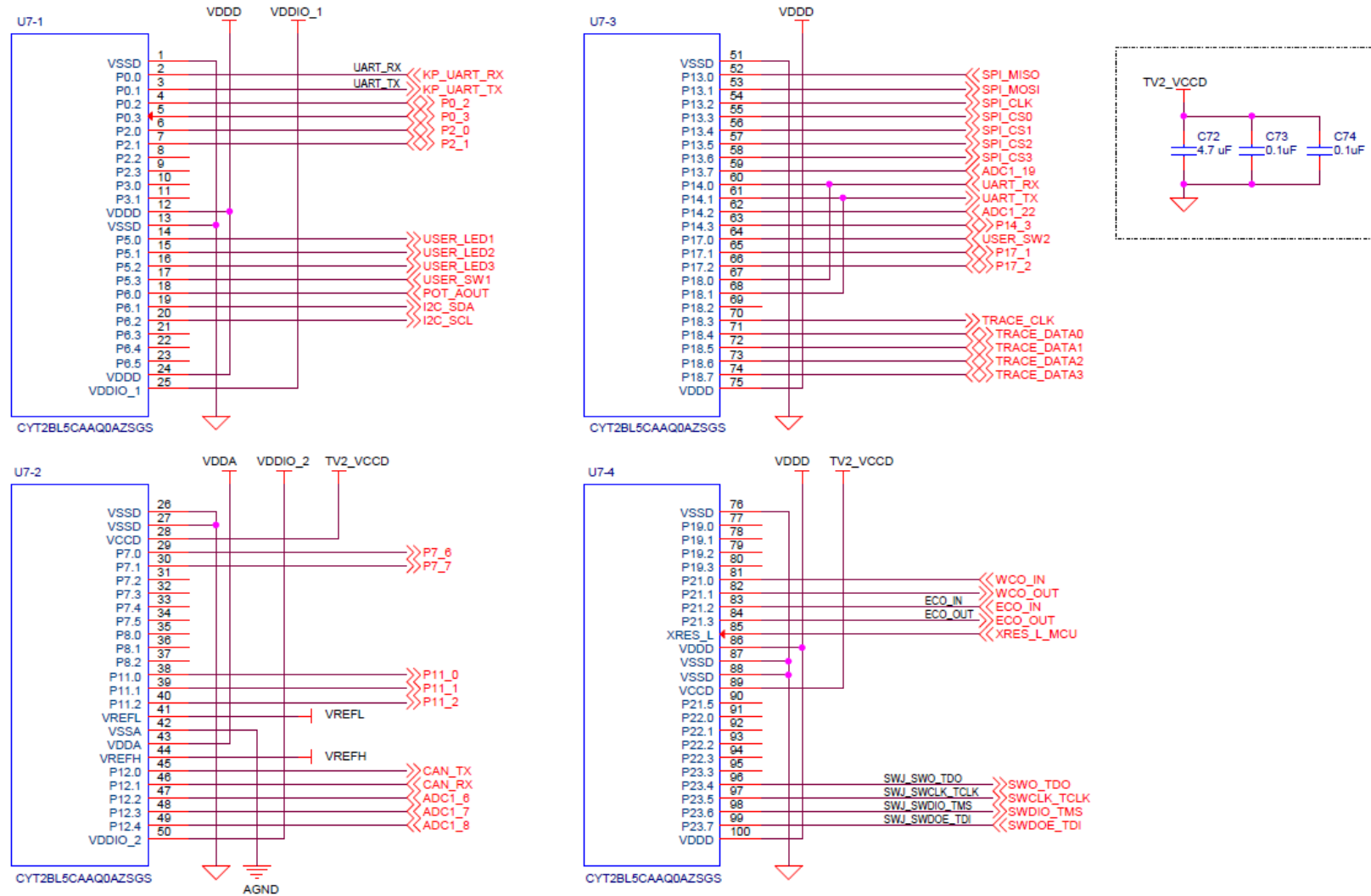

Figure 15 TRAVEO™ T2G-B-E-1M 100-pin MCU

General safety instructions

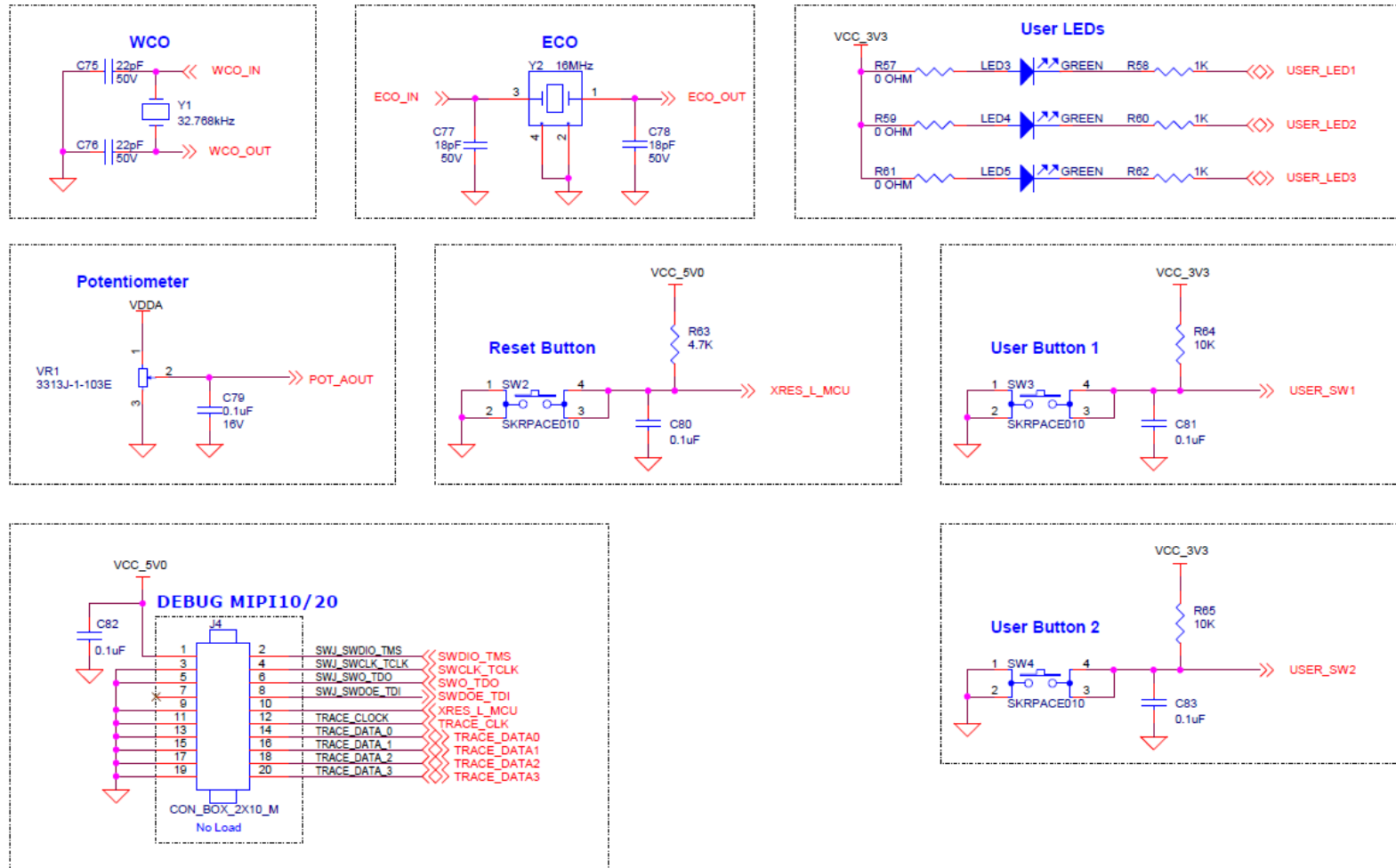

Figure 16 Peripheral interface

General safety instructions

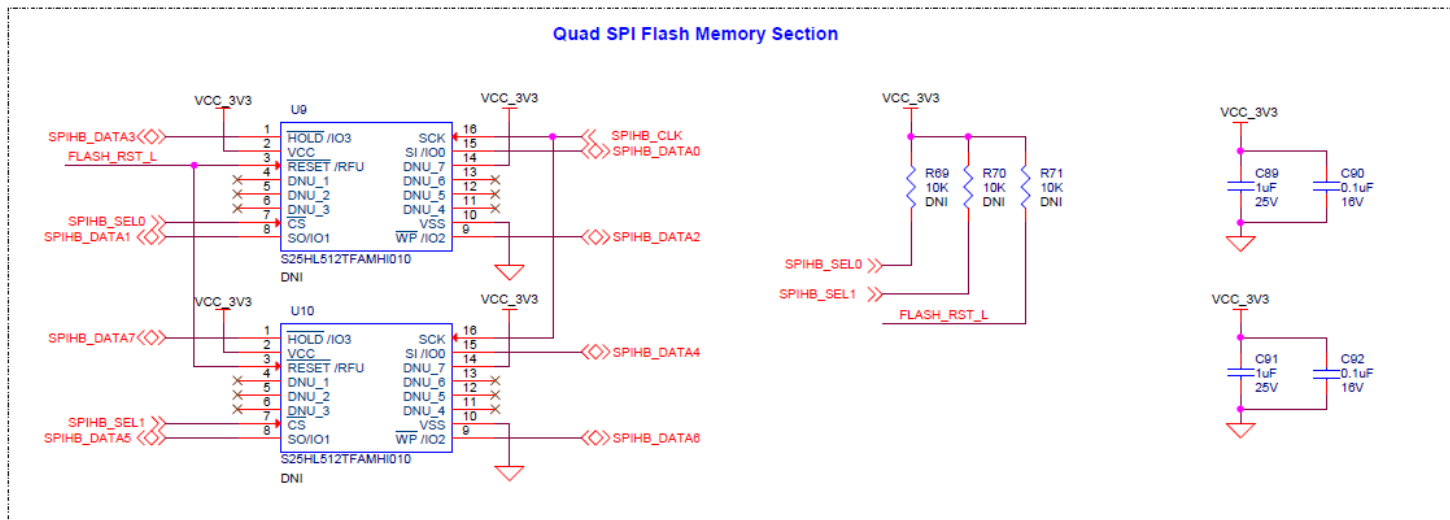
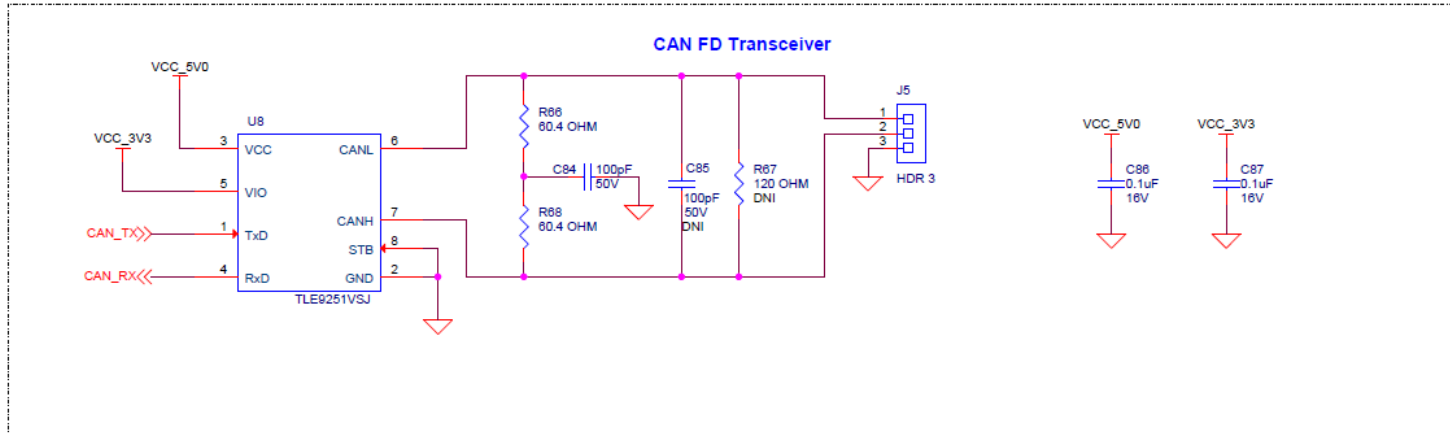

Figure 17 CAN and QSPI interface

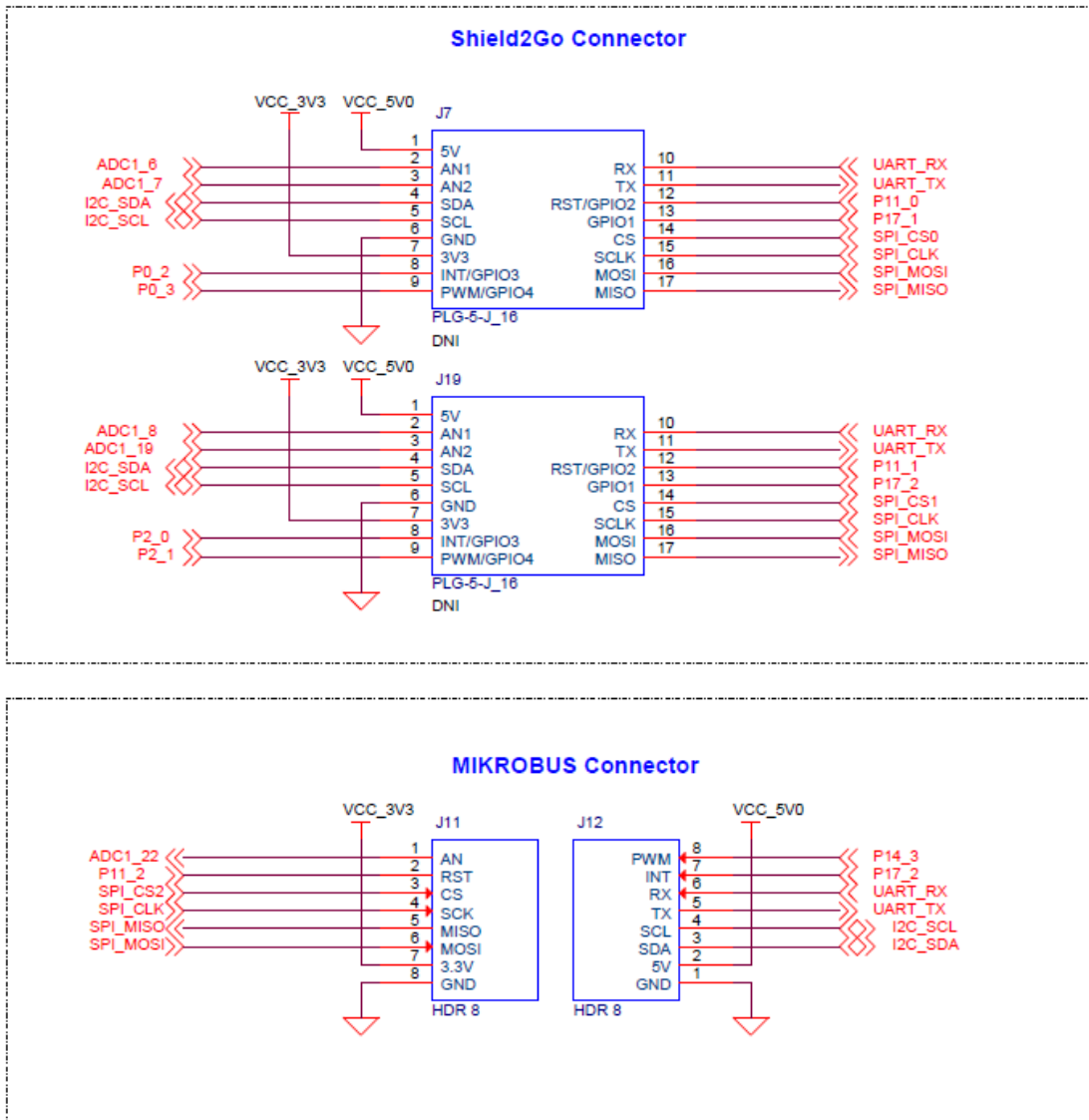

Figure 18 Shield2Go / MikroBUS

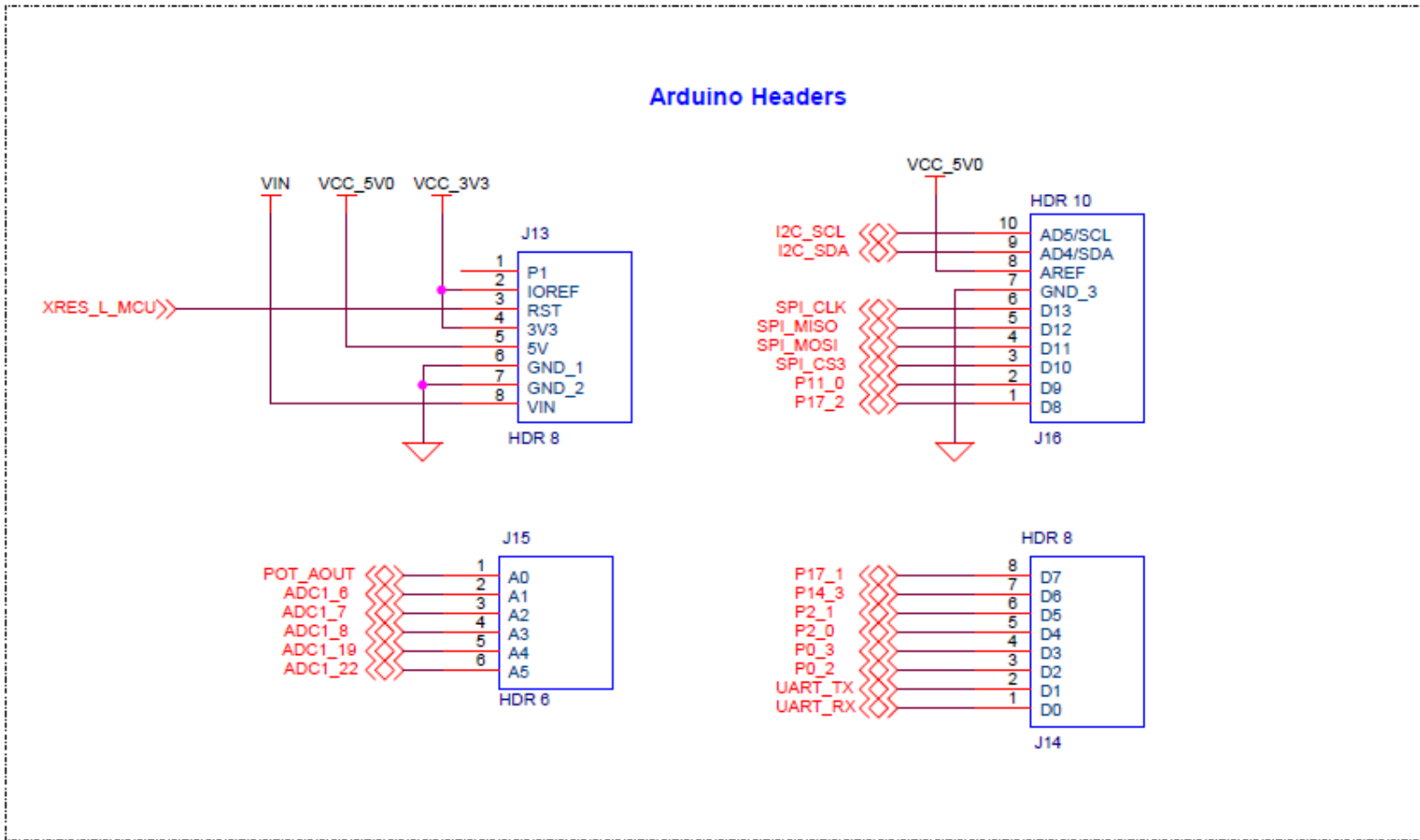

Figure 19 Arduino Headers

General safety instructions

Expansion Headers

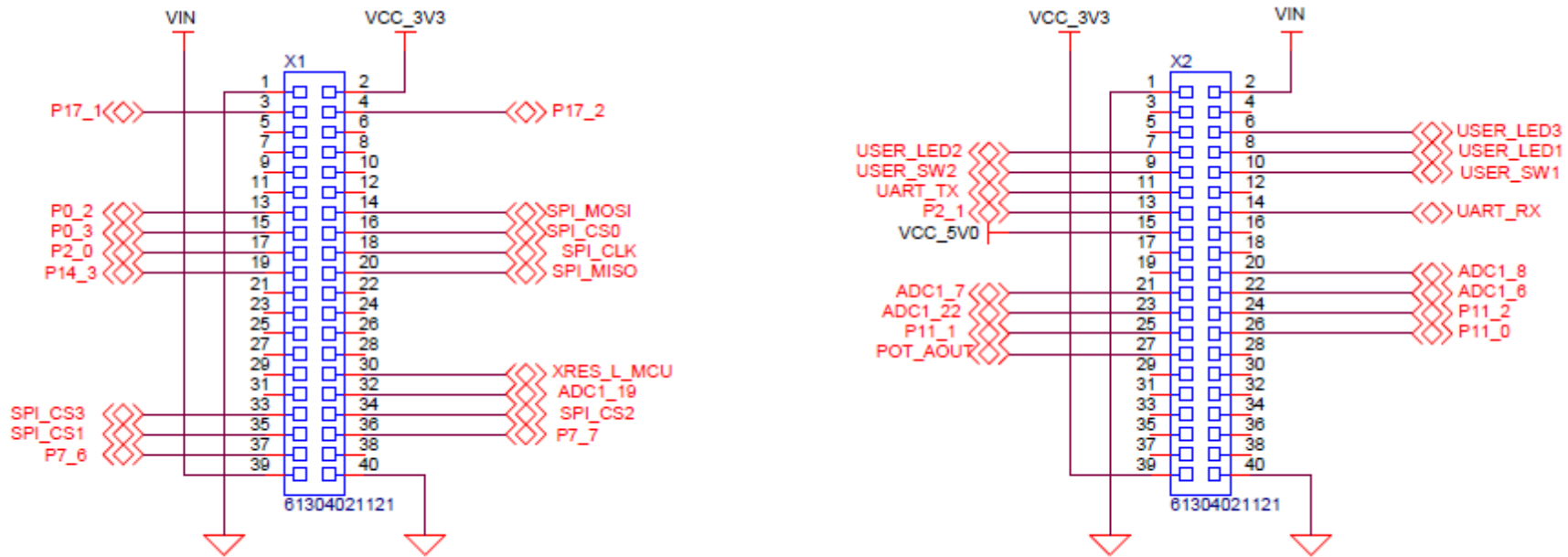

Figure 20 Expansion headers



General safety instructions

4.4 Layouts

This section shows the board layouts of the TRAVEO™ T2G Body Entry Lite Kit.

General safety instructions

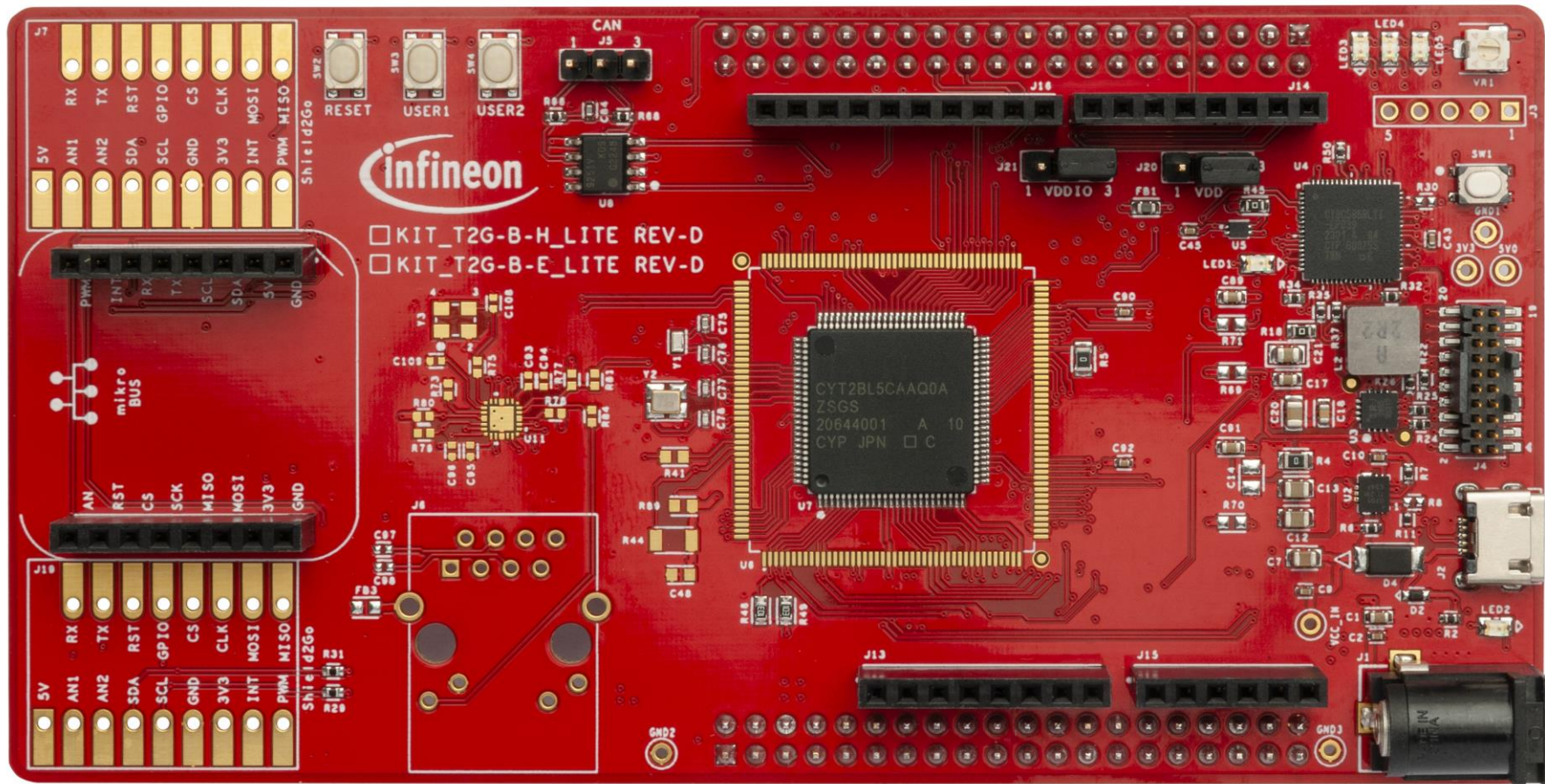

Figure 21 Top view

Revision history

Revision history

Document revision	Date	Description
**	2023-07-20	Initial release
*A	2023-10-19	Corrected website links. Fixed pinout (Figure 3) and fixed schematics.

Trademarks

All referenced product or service names and trademarks are the property of their respective owners.

Edition 2023-10-19

Published by

Infineon Technologies AG
81726 Munich, Germany

© 2023 Infineon Technologies AG.
All Rights Reserved.

Do you have a question about this document?

Email: erratum@infineon.com

Document reference

002-37239 Rev. *A

Important notice

The information given in this document shall in no event be regarded as a guarantee of conditions or characteristics ("Beschaffheitsgarantie")

With respect to any examples, hints or any typical values stated herein and/or any information regarding the application of the product, Infineon Technologies hereby disclaims any and all warranties and liabilities of any kind, including without limitation warranties of non-infringement of intellectual property rights of any third party.

In addition, any information given in this document is subject to customer's compliance with its obligations stated in this document and any applicable legal requirements, norms and standards concerning customer's products and any use of the product of Infineon Technologies in customer's applications.

The data contained in this document is exclusively intended for technically trained staff. It is the responsibility of customer's technical departments to evaluate the suitability of the product for the intended application and the completeness of the product information given in this document with respect to such application.

Warnings

Due to technical requirements products may contain dangerous substances. For information on the types in question please contact your nearest Infineon Technologies office.

Except as otherwise explicitly approved by Infineon Technologies in a written document signed by authorized representatives of Infineon Technologies, Infineon Technologies' products may not be used in any applications where a failure of the product or any consequences of the use thereof can reasonably be expected to result in personal injury.

X-ON Electronics

Largest Supplier of Electrical and Electronic Components

Click to view similar products for [Interface Development Tools](#) category:

Click to view products by [Infineon](#) manufacturer:

Other Similar products are found below :

[CY4607M](#) [XR17V358/SP339-E8-EB](#) [TW-DONGLE-USB](#) [XR21B1424IV64-0A-EVB](#) [P0551](#) [5346](#) [SI32185ACB10SL1KIT](#)

[RAA2S4252EXT](#) [4901](#) [DFR0979](#) [LIME2-SHIELD](#) [EM01-D](#) [USB TO TTL](#) [USB TO RS485](#) [USB-CAN-A](#) [MIKROE-5492](#)

[RTKH4Z2501S00000BE](#) [5956](#) [5964](#) [103030295](#) [MIKROE-2335](#) [KIT_MINIWIGGLER_3_USB](#) [KITXMC4XCOMETH001TOBO1](#)

[SI871XSOIC8-KIT](#) [1764](#) [1833](#) [1862](#) [ZSC31010KITV2.1](#) [EVB-USB82514](#) [ATAB663231A-V1.2](#) [ATAB663254A-V1.2](#) [2264](#)

[MCP23X17EV](#) [PS09-EVA-KIT](#) [MAX96708COAXEVKIT#](#) [MAXPOWERTOOL002#](#) [SMA2RJ45EVK/NOPB](#) [FR12-0002](#) [MAFR-000667-](#)

[000001](#) [MAFR-000589-000001](#) [MAFR-000553-000001](#) [BOB-13263](#) [BP359C](#) [ORG4572-R01-UAR](#) [XR21B1422IL40-0A-EVB](#)

[XR21B1420IL28-0A-EVB](#) [284](#) [SKYFR-000743](#) [SKYFR-000827](#) [SKYFR-000982](#)