

KIT_T2G-B-H_LITE user guide

About this document

Scope and purpose

This document serves as a guide for using the KIT_T2G-B-H_LITE. This document explains the kit operation, describes the out-of-the-box (OOB) example and its operation, and the hardware details of the board.

Intended audience

This document is intended for TRAVEO™ T2G Body High Lite evaluation kit users.

Reference documents

This user guide should be read in conjunction with the following documents:

- AN235305 - Getting started with TRAVEO™ T2G family MCUs in ModusToolbox™
- [TRAVEO™ T2G Body High datasheet](#)

Table of contents

Table of contents

About this document..... 1

Table of contents..... 2

Safety and regulatory compliance information 3

General safety instructions 3

1 Introduction 4

1.1 Getting started.....4

1.2 Additional learning resources.....5

1.3 Technical support.....5

1.4 Documentation conventions5

1.5 Abbreviations and definitions.....5

2 Kit details..... 7

2.1 Kit contents7

2.2 Board details7

3 Kit operation14

3.1 Theory of operation.....14

3.2 BSP selection18

3.3 KitProg3: Onboard programmer/debugger18

3.3.1 Programming and debugging using ModusToolbox™ software18

3.3.2 USB-UART bridge22

4 Hardware23

4.1 KIT_T2G-B-H_Lite kit connections23

4.1.1 USER LEDs23

4.1.2 USER switches23

4.1.3 RESET switch23

4.1.4 MODE switch.....24

4.2 System configuration24

4.3 Schematics24

4.4 Layouts40

5 Known limitations.....42

Revision history.....43

Safety and regulatory compliance information

Safety and regulatory compliance information

This kit is intended for development purposes only. Users are advised to test and evaluate this kit in an RF development environment.

Safety evaluation for this kit is done in factory default settings using default accessories shipped with the kit. All evaluations for safety are carried out using a 5-V (USB 2.0, @ 500 mA) supply. Attaching additional wiring to this product or modifying the product operation from the factory default may affect its performance and cause interference with other apparatus in the immediate vicinity. If such interference is detected, suitable mitigating measures should be taken.

This kit is not a finished product and when assembled may not be resold or otherwise marketed unless all required authorizations are first obtained. Contact [Infineon support](#) for details.



These kits contain electrostatic discharge (ESD) sensitive devices. Electrostatic charges readily accumulate on the human body and any equipment, which can cause a discharge without detection. Permanent damage may occur on devices subjected to high-energy discharges. Proper ESD precautions are recommended to avoid performance degradation or loss of functionality. Store unused kits in the protective shipping package.



End-of-life/product recycling

The end-of-life cycle for this kit is five years from the date of manufacture mentioned on the back of the box. Contact your nearest recycler to discard the kit.

General safety instructions

ESD protection

ESD can damage boards and associated components. Infineon recommends that you perform procedures only at an ESD workstation. If an ESD workstation is unavailable, use appropriate ESD protection by wearing an anti-static wrist strap attached to the chassis ground (any unpainted metal surface) on your board when handling parts.

Handling boards

This board is sensitive to ESD. Hold the board only by its edges. After removing the board from its box, place it on a grounded, static-free surface. Use a conductive foam pad, if available. Do not slide the board over any surface.

Introduction

1 Introduction

Thank you for your interest in the KIT_T2G-B-H_LITE. The KIT_T2G-B-H_LITE enables you to evaluate and develop your applications using the [TRAVEO™ T2G Body High MCU](#) (hereafter called “TRAVEO™ T2G-B-H MCU”).

TRAVEO™ T2G-B-H MCU is designed for automotive applications. TRAVEO™ T2G-B-H MCU is a true programmable embedded system-on-chip, integrating up to two 350-MHz Arm® Cortex®-M7 as the primary application processors, a 100-MHz Arm® Cortex®-M0+ that supports low-power operations, up to 8 MB flash and 1 MB SRAM, Secure Digital Host Controller (SDHC) supporting SD/SDIO/eMMC interfaces, programmable analog and digital peripherals that allow faster time-to-market.

The evaluation board carries a TRAVEO™ T2G-B-H, a MikroBUS and two Sheild2Go connectors, and headers compatible with Arduino for interfacing Arduino shields. In addition, the board features an onboard programmer/debugger (KitProg3), a 512-Mbit QSPI NOR flash, CAN FD transceiver, Ethernet PHY transceiver with RJ45 connector interface, a micro-B connector for USB device interface, three user LEDs, one potentiometer, and two push buttons. The board supports operating voltages from 3.3 V to 5.0 V for TRAVEO™ T2G-B-H.

You can use ModusToolbox™ software to develop and debug your TRAVEO™ T2G-B-H MCU projects. [ModusToolbox™ software](#) is a set of tools that enable you to integrate these devices into your existing development methodology.

If you are new to TRAVEO™ T2G-B-H MCU and ModusToolbox™ software, see the application note AN235305 - Getting started with TRAVEO™ T2G Family MCUs in ModusToolbox™ software to help you familiarize with the TRAVEO™ T2G-B-H MCU and help you create your own design using the Eclipse IDE for ModusToolbox™ software.

1.1 Getting started

This guide will help you to get acquainted with this evaluation kit:

- The [Kit details](#) chapter provides the kit and package details and board details.
- The [Kit operation](#) chapter describes the major features of the [KIT_T2G-B-H_LITE](#) and functionalities such as programming, debugging, the USB-UART, and USB-I2C bridges.
- The [Hardware](#) chapter provides a detailed hardware description, kit schematics, and the bill of materials (BOM).
- Application development using [KIT_T2G-B-H_LITE](#) is supported in ModusToolbox™ software. ModusToolbox™ software is a free development eco-system that includes the Eclipse IDE for ModusToolbox™ software and the TRAVEO™ T2G-B-H SDK with TRAVEO™ T2G-B-H MCU. Using ModusToolbox™ software, you can enable and configure device resources, and middleware libraries; write C/assembly source code; and program and debug the device. You can download the software from the [ModusToolbox™ home page](#). See the ModusToolbox™ software installation guide for additional information.
- There is a wide range of code examples to evaluate the [KIT_T2G-B-H_LITE](#). These examples help you familiarize TRAVEO™ T2G-B-H MCU and create your own design. These examples can be accessed through the ModusToolbox™ Project Creator tool. Alternatively, you can also visit Infineon’s code example page to access these examples:
 - [Code examples for ModusToolbox™ software](#)

Introduction

1.2 Additional learning resources

Infineon provides a wealth of data at www.infineon.com/cms/en/product/microcontroller/32-bit-traveo-t2g-arm-cortex-microcontroller to help you to select the right TRAVEO™ T2G MCU device for your design and to help you quickly and effectively integrate the device into your design.

1.3 Technical support

For assistance, go to www.infineon.com/support. Visit community.infineon.com to ask your questions in Infineon developer community.

You can also use the following support resources if you need quick assistance:

- [Self-help \(Technical documents\)](#)

1.4 Documentation conventions

Table 1 Document conventions for guides

Convention	Usage
Courier New	Displays user-entered text and source code
<i>Italics</i>	Displays file names and reference documentation: Read about the <i>sourcefile.hex</i> file in the <i>PSoC™ Creator user guide</i> .
File > Open	Represents menu paths: File > Open > New Project
Bold	Displays commands, menu paths, and icon names in procedures: Click the File icon and then click Open .
Times New Roman	Displays an equation: $2 + 2 = 4$
Text in gray boxes	Describes Cautions or unique functionality of the product.

1.5 Abbreviations and definitions

Table 2 Abbreviations

Abbreviation	Definition
ADC	analog-to-digital converter
BOM	bill of materials
CINT	Integration Capacitor
CMOD	Modulator Capacitor
CPU	central processing unit
CSD	capacitive sigma delta
CSX	CAPSENSE™ Crosspoint
CTANK	Shield Tank Capacitor
DC	direct current
ECO	external crystal oscillator
ESD	electrostatic discharge
FPC	flexible printed circuit

Introduction

Abbreviation	Definition
GPIO	general-purpose input/output
IC	integrated circuit
IDE	integrated development environment
IoT	Internet of Things
I2C	inter-integrated circuit
I2S	Inter-IC Sound
LED	light-emitting diode
LPO	low power oscillator
PC	personal computer
PDL	peripheral driver library
QSPI	Quad serial peripheral interface
SDHC	Secure Digital Host Controller
SDIO	Secure Digital Input Output
SDK	software development kit
SMIF	Serial Memory Interface
SPI	Serial Peripheral Interface
SRAM	static random-access memory
SWD	Serial Wire Debug
UART	universal asynchronous receiver transmitter
USB	Universal Serial Bus
WCO	watch crystal oscillator

Kit details

2 Kit details

2.1 Kit contents

- KIT_T2G-B-H_LITE REV D Board

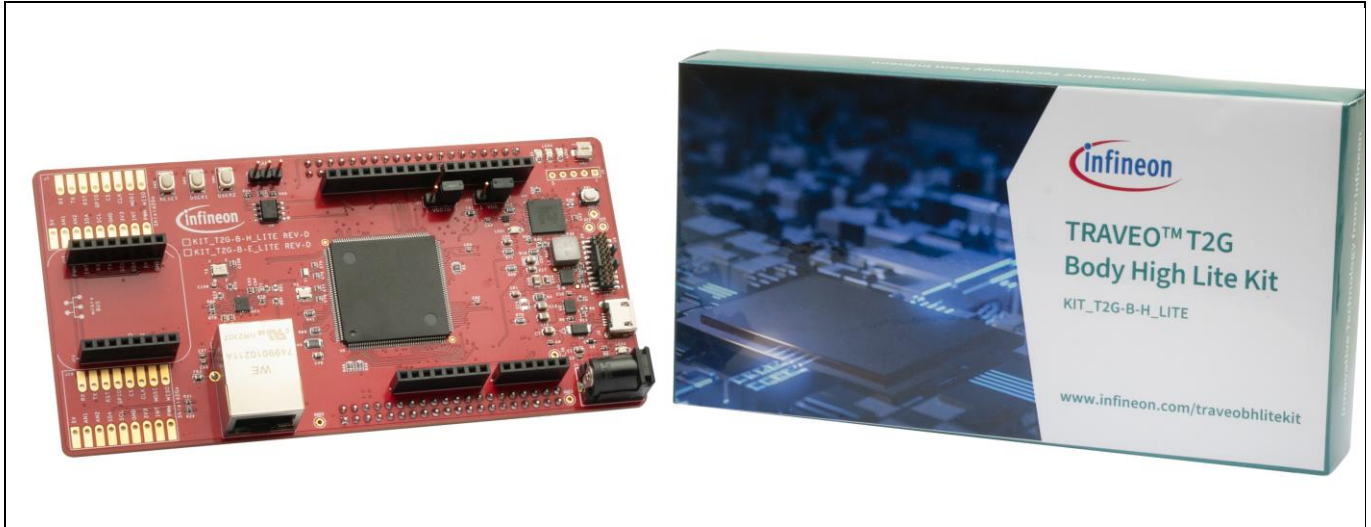

Figure 1 Kit contents

Inspect the contents of the kit; if you find any part missing, go to <https://www.infineon.com/cms/en/product/microcontroller/32-bit-traveo-t2g-arm-cortex-microcontroller/traveo-t2g-cyt4bf-series>.

2.2 Board details

The **KIT_T2G-B-H_LITE** has the following features:

- TRAVEO™ T2G-B-H MCU – CYT4BF8CDDQ0AESGS. See the device [datasheet](#).
- 512-Mb external Quad SPI NOR flash that provides a fast, expandable memory for data and code.
- KitProg3 on-board SWD programmer/debugger, USB-UART, and USB-I2C bridge functionality.
- A micro-B connector for USB device interface
- Selectable input supply voltages of 3.3 V and 5.0 V for the TRAVEO™ T2G-B-H MCU.
- Three user LEDs, two user buttons, and a reset button for the TRAVEO™ T2G-B-H MCU
- A potentiometer which can be used to simulate analog sensor output
- A mode button and a mode LED for KitProg3

Kit details

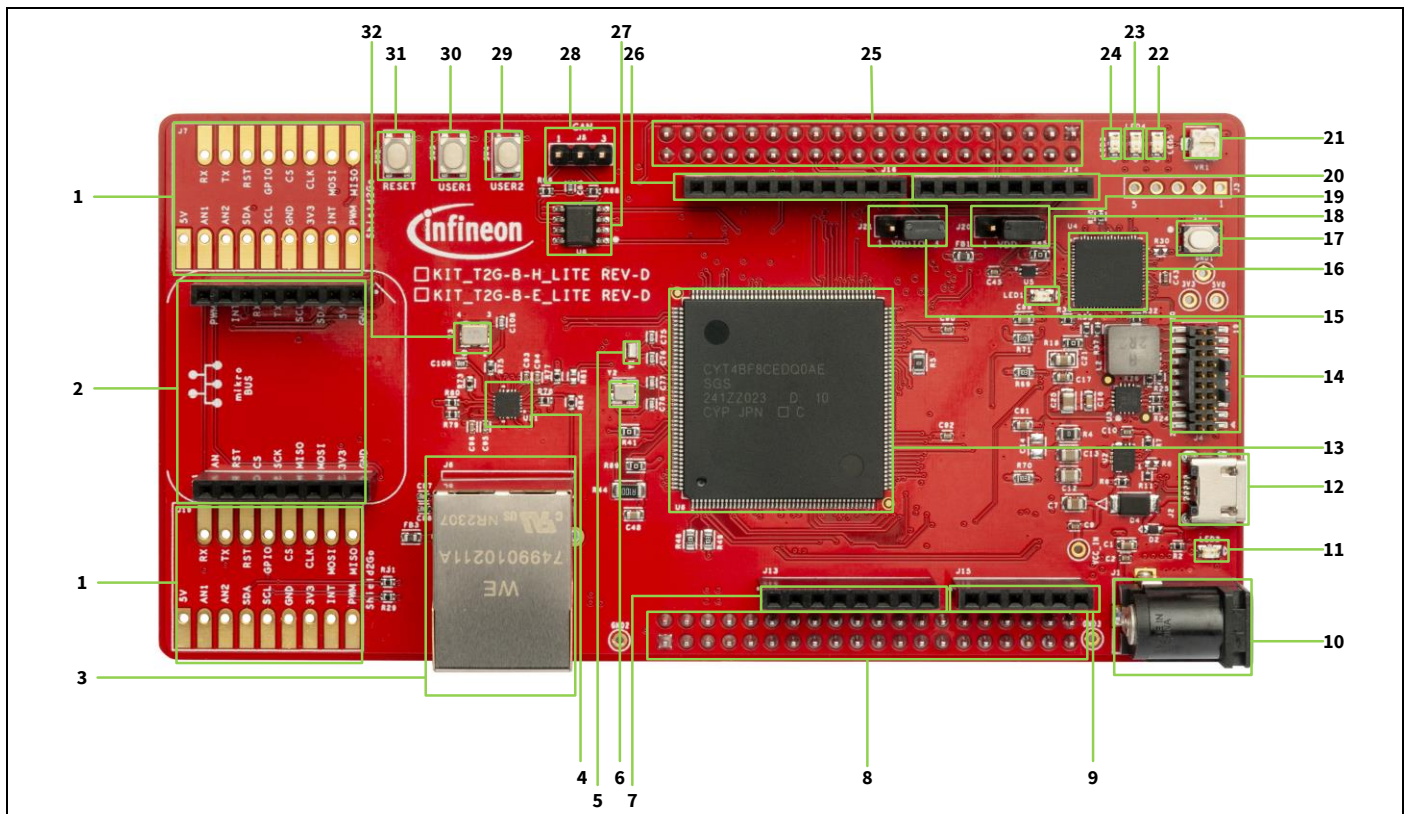

Figure 2 KIT_T2G-B-H_LITE board – top view

1. Shield2Go connectors (Not Mounted) (J7, J19)
2. MikroBUS connectors (J11, J12)
3. RJ45 Ethernet connector (J6)
4. Ethernet physical layer (PHY) transceiver (U11)
5. 32.768-kHz oscillator for WCO (Y1)
6. 16-MHz oscillator for ECO (Y2)
7. 8-pin Arduino header (J13)
8. Expansion header 1 (X1 on the bottom side)
9. 6-pin Arduino header (J15)
10. DC Power Jack (J1)
11. Power LED (LED2)
12. KitProg3 USB Micro-B Connector (J2)
13. TRAVEO™ T2G microcontroller (U6)
14. MIPI10/20 DEBUG connector (J4)
15. T2G-B-H VDDIO voltage selection jumper (J21)
16. PSoc 5LP based KitProg3 (U4)
17. Mode switch (SW1)
18. KitProg3 Status LED (LED1)
19. T2G-B-H VDD voltage selection jumper (J20)
20. 8-pin Arduino header (J14)
21. Potentiometer (VR1)

Kit details

- 22. USER LED3 (LED5)
- 23. USER LED2 (LED4)
- 24. USER LED1 (LED3)
- 25. Expansion Header 2 (X2 on the bottom side)
- 26. 10-pin Arduino header (J16)
- 27. CAN FD transceiver (U8)
- 28. CAN FD connector (J5)
- 29. USER2 button (SW4)
- 30. USER1 button (SW3)
- 31. RESET button (SW2)
- 32. 25-MHz crystal for Ethernet transceiver (Y3)

Kit details

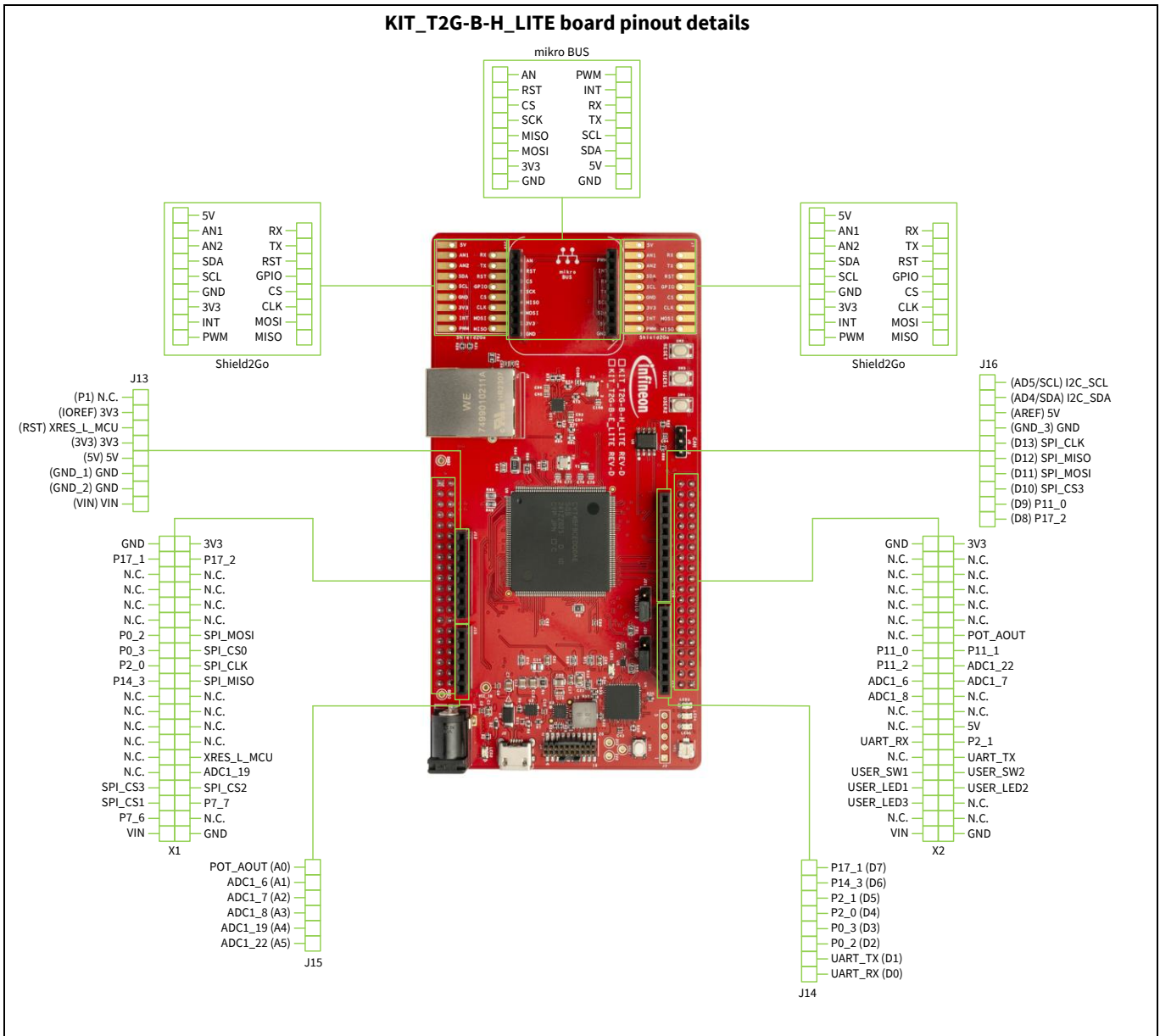

Figure 3 KIT_T2G-B-H_LITE board pinout

Table 3 KIT_T2G-B-H_LITE board pinout

Pin	Primary onboard function	Secondary onboard function	Connection details
TRAVEO™ T2G-B-H MCU pins			
XRES	Hardware reset	–	–
P12[0]	CAN transmit CAN_TX	–	Connected to TxD of CAN FD transceiver TLE9251VSJ
P12[1]	CAN receive CAN_RX	–	Connected to RxD of CAN FD transceiver TLE9251VSJ
P6[3]	SPIHB_CLK	–	Connected to SCK of QSPI flash S25HL512TFAMHI010

Kit details

Pin	Primary onboard function	Secondary onboard function	Connection details
P6[5]	SPIHB_SEL0	–	Connected to CS of QSPI flash S25HL512TFAMHI010
P6[0]	Potentiometer (POT) output POT_AOUT	Arduino header (J15.1)	–
P7[1]	SPIHB_DATA0	–	Connected to IO0 of QSPI flash S25HL512TFAMHI010 (U9)
P7[2]	SPIHB_DATA1	–	Connected to IO1 of QSPI flash S25HL512TFAMHI010 (U9)
P7[3]	SPIHB_DATA2	–	Connected to IO2 of QSPI flash S25HL512TFAMHI010 (U9)
P7[4]	SPIHB_DATA3	–	Connected to IO3 of QSPI flash S25HL512TFAMHI010 (U9)
P7[5]	SPIHB_DATA4	–	Connected to IO0 of QSPI flash S25HL512TFAMHI010 (U10)
P8[0]	SPIHB_DATA5	–	Connected to IO0 of QSPI flash S25HL512TFAMHI010 (U10)
P8[1]	SPIHB_DATA6	–	Connected to IO0 of QSPI flash S25HL512TFAMHI010 (U10)
P8[2]	SPIHB_DATA7	–	Connected to IO0 of QSPI flash S25HL512TFAMHI010 (U10)
P13[0]	D12 – header compatible with Arduino (J16.5)	Expansion header (X1.20)	–
P13[1]	D11 – header compatible with Arduino (J16.4)	Expansion header (X1.14)	–
P13[2]	D13 – header compatible with Arduino (J16.6)	Expansion header (X1.18)	–
P13[6]	D10 – header compatible with Arduino (J16.3)	Expansion header (X1.33)	–
P11[0]	D9 – header compatible with Arduino (J16.2)	Shield2Go Connector (J7.12) Expansion header (X2.26)	–
P17[2]	D8 – header compatible with Arduino (J16.1)	Shield2Go Connector (J19.13) Expansion header (X1.4)	–
P14[0]	UART_RX	Shield2Go Connector (J7.10, J19.10) MikroBUS Connector (J12.6)	This pin is connected to the KitProg3 UART Tx pin.

Kit details

Pin	Primary onboard function	Secondary onboard function	Connection details
P14[1]	UART_TX	Pin D1 of connector J4.2 compatible with Arduino Shield2Go Connector (J7.11, J19.11) MIKROBUS Connector (J12.5)	This pin is connected to the KitProg3 UART Rx pin. Remove R132 and R142, and install R136, to connect to Pin D1 of connector J4.2 compatible with Arduino.
P0[2]	Pin D2 of connector J14.3 compatible with Arduino	-	-
P0[3]	Pin D3 of connector J14.4 compatible with Arduino	-	-
P2[0]	Pin D4 of connector J14.5 compatible with Arduino	-	-
P2[1]	Pin D5 of connector J14.6 compatible with Arduino	-	-
P14[3]	Pin D6 of connector J14.7 compatible with Arduino	-	-
P17[1]	Pin D7 of connector J14.8 compatible with Arduino	-	-
P12[2]	A1 – header compatible with Arduino (J15.2)	-	-
P12[3]	A2 – header compatible with Arduino (J15.3)	-	-
P12[4]	A3 – header compatible with Arduino (J15.4)	-	-
P13[7]	A4 – header compatible with Arduino (J15.5)	-	-
P14[2]	A5 – header compatible with Arduino (J15.6)	-	-
P6[1]	I2C SDA - Common I2C SDA pin for KitProg3 USB-I2C bridge	I2C SDA pin Arduino header (J16.9)	-
P6[2]	I2C SCL - Common I2C SCL pin for KitProg3 USB-I2C bridge	I2C SCL pin on Arduino header (J16.10)	-
P5[0]	USER LED1 (LED1)	ExpansionConnector (X2.8)	-
P5[1]	USER LED2 (LED2)	ExpansionConnector (X2.7)	-

Kit details

Pin	Primary onboard function	Secondary onboard function	Connection details
P5[2]	USER LED3 (LED3)	ExpansionConnector (X2.6)	-
P5[3]	User Button (USER BUTTON1)	Expansion Connector (X2.10)	-
P17[0]	User Button (USER BUTTON2)	Expansion Connector (X2.9)	-
P21[0]	WCO IN (Y1)	-	32.768-kHz watch crystal oscillator input
P21[1]	WCO OUT (Y1)	-	32.768-kHz watch crystal oscillator output
P21[2]	ECO IN (Y2)	-	16-MHz external crystal oscillator input
P21[3]	ECO OUT (Y2)	-	16-MHz external crystal oscillator input
P23[4]	SWO_TDO	DEBUG MIPI 10/20 Connector (J4.6)	-
P23[5]	SWCLK_TCLK	DEBUG MIPI 10/20 Connector (J4.4)	-
P23[6]	SWDIO_TMS	DEBUG MIPI 10/20 Connector (J4.2)	-
P23[7]	SWDOE_TDI	DEBUG MIPI 10/20 Connector (J4.8)	-
P18[0]	ETH_REFCLK	-	The Ethernet signals are connected to U11 Ethernet PHY transceiver in RMII configuration mode.
P18[4]	ETH_TXD0	-	
P18[5]	ETH_TXD1	-	
P18[1]	ETH_TXEN	-	
P19[0]	ETH_RXD0	-	
P19[1]	ETH_RXD1	-	
P21[5]	ETH_RXCTL	-	
P3[1]	ETH_MDC	-	
P3[0]	ETH_MDIO	-	

Kit operation

3 Kit operation

3.1 Theory of operation

The TRAVEO™ T2G-B-H evaluation board is built around TRAVEO™ T2G-B-H MCU. For details of device features, see the device [datasheet](#).

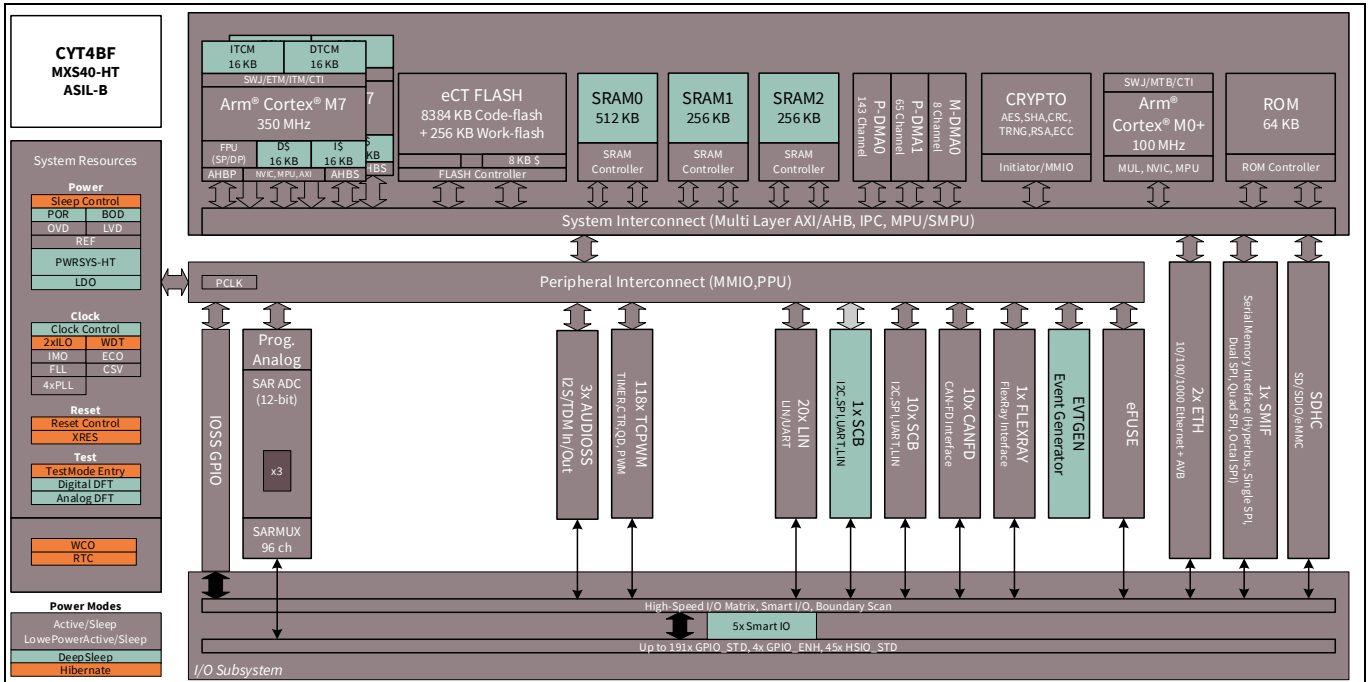

Figure 4 TRAVEO™ T2G-B-H MCU block diagram

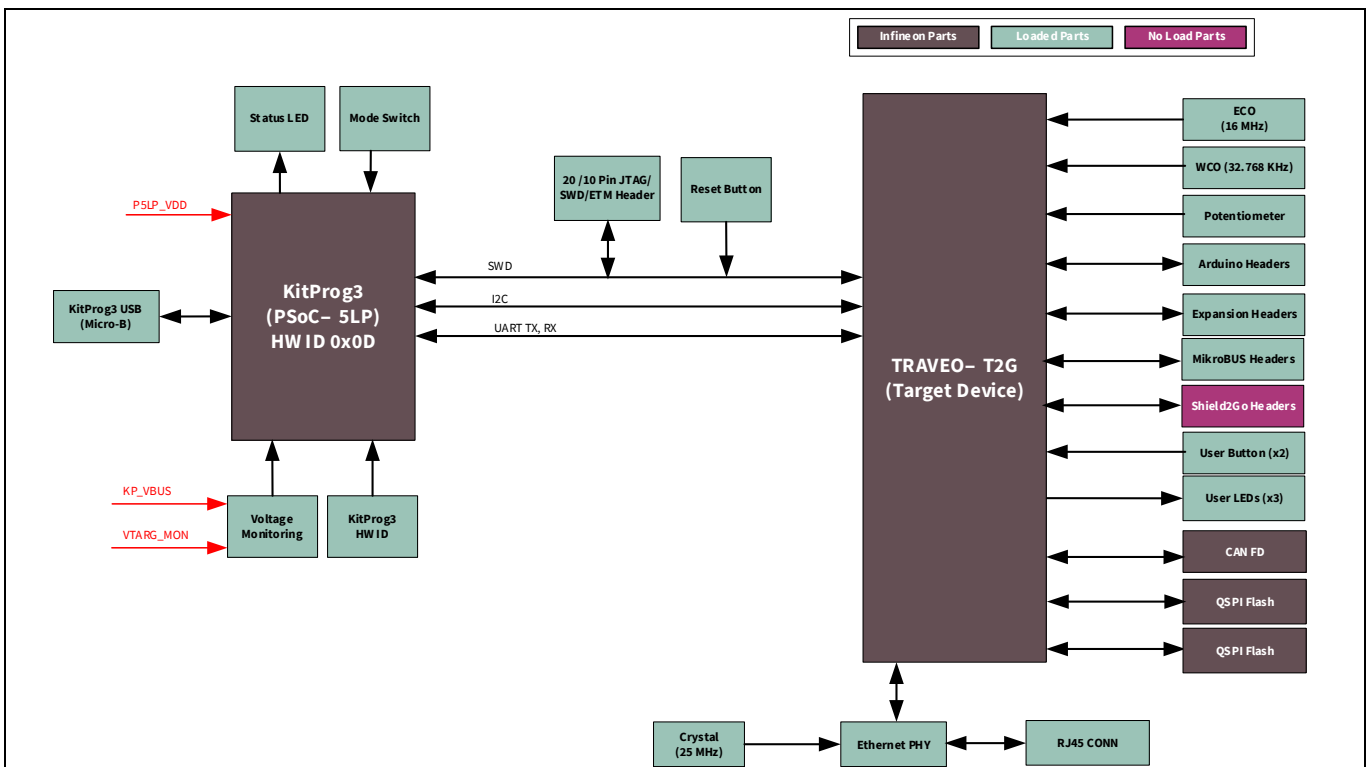

Figure 5 Block diagram of KIT_T2G-B-H_LITE board

Kit operation

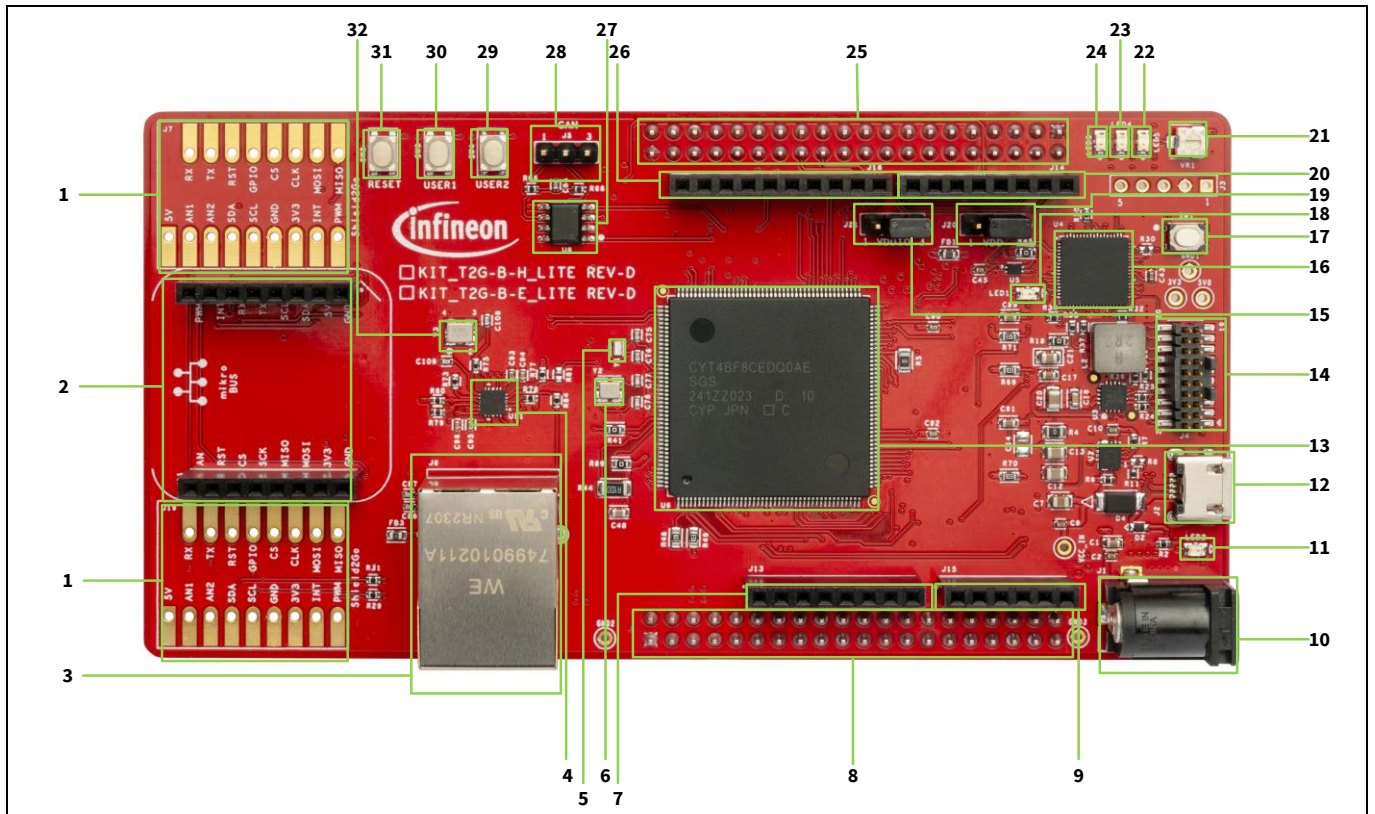

Figure 6 KIT_T2G-B-H_LITE board - top view

Kit operation

The KIT_T2G-B-H_LITE board has the following peripherals:

Table 4 Peripheral details

Sl. No.	Peripheral	Description
1.	Shield2Go Connector	Optional connector for Shield2Go Interface (DNI)
2.	MikroBUS Connector	Optional connector for MikroBUS Interface (DNI)
3.	RJ45 Ethernet connector (J6)	RJ45 Ethernet connector port to connect the kit to the Ethernet network.
4.	Ethernet physical layer (PHY) transceiver (U11)	Ethernet PHY for connecting Ethernet network.
5.	32.768 kHz crystal for WCO (Y1)	Oscillator for WCO clock.
6.	16 MHz crystal for ECO (Y2)	Oscillator for ECO clock.
7.	Digital I/O headers compatible with Arduino Uno R3 (J14)	Bring out pins from TRAVEO™ T2G-B-H MCU to interface with shields compatible with Arduino. Some of these pins are multiplexed with onboard peripherals and are not connected to TRAVEO™ T2G-B-H MCU by default. For detailed information on how to rework the kit to access these pins, see Table 3 .
8.	Expansion headers (X1)	These headers provide connectivity to TRAVEO™ T2G-B-H MCU GPIOs that are not connected to the other onboard functions.
9.	Analog-IN header compatible with Arduino Uno R3 (J15)	Bring out pins from TRAVEO™ T2G-B-H MCU to interface with shields compatible with Arduino. Some of these pins are multiplexed with onboard peripherals and are not connected to TRAVEO™ T2G-B-H MCU by default. For detailed information on how to rework the kit to access these pins, see Table 3 .
10.	External power supply VIN connector (J1)	Connect to external 12 V/3 A DC power adapter.
11.	Power LED (LED2)	Power supply ON/OFF LED status indicator.
12.	KitProg3 USB connector (J2)	Connect to a PC to use the KitProg3 onboard programmer and debugger and to provide power to the board.
13.	T2G-B-H microcontroller (U6)	TRAVEO™ T2G MCU device used on the kit.
14.	DEBUG MIPI 10/20 connector (J4)	Connect to an Embedded Trace Macrocell (ETM)-compatible programmer/debugger. This is not loaded by default.
15.	T2G-B-H VDDIO voltage selection jumper (J21)	J12 connects MCU VDDIO2 to T2G-B-H_VDD which is the outcome of J10 (VCC_3V3 or VCC_5V0) power supply selection.
16.	KitProg3 (PSoC™ 5LP) programmer and debugger (CY8C5868LTI-LP039, U4)	The PSoC™ 5LP device (CY8C5868LTI-LP039) serving as KitProg3, is a multi-functional system, which includes an SWD programmer, debugger, USB-I2C bridge, and USB-UART bridge. For more details, see the KitProg3 user guide .
17.	KitProg3 programming mode selection button (SW1)	Use this button to switch between various modes of operation of KitProg3. Note that this board supports only

Kit operation

Sl. No.	Peripheral	Description
		CMSIS-DAP BULK mode. For more details, see the KitProg3 user guide . This button function is reserved for future use.
18.	KitProg3 status LED (LED1)	Amber LED (LED1) indicates the status of KitProg3. For details on the KitProg3 status, see the KitProg3 user guide .
19.	T2G-B-H VDD voltage selection jumper (J20)	J12 connects MCU VDDIO2 to T2G-B-H_VDD which is the outcome of J10 (VCC_3V3 or VCC_5V0) power supply selection.
20.	Power header compatible with Arduino Uno R3 (J13)	Powers the shields compatible with Arduino. It also has a provision to power the kit through the VIN input.
21.	Potentiometer (VR1)	10-kΩ potentiometer connected to TRAVEO™ T2G-B-H MCU pin P6[0]. It can be used to simulate a sensor output to TRAVEO™ T2G-B-H MCU.
22.	User LEDs (LED5)	The user LEDs can operate at the entire operating voltage range of the TRAVEO™ T2G-B-H MCU. The LEDs are active LOW, so the pins must be driven to the ground to turn ON the LEDs.
23.	User LEDs (LED4)	The user LEDs can operate at the entire operating voltage range of the TRAVEO™ T2G-B-H MCU. The LEDs are active LOW, so the pins must be driven to the ground to turn ON the LEDs.
24.	User LEDs (LED3)	The user LEDs can operate at the entire operating voltage range of the TRAVEO™ T2G-B-H MCU. The LEDs are active LOW, so the pins must be driven to the ground to turn ON the LEDs.
25.	Expansion Headers (X2)	These headers provide connectivity to TRAVEO™ T2G-B-H MCU GPIOs that are not connected to the other onboard functions.
26.	Digital I/O headers compatible with Arduino Uno R3 (J16)	Bring out pins from TRAVEO™ T2G-B-H MCU to interface with shields compatible with Arduino. Some of these pins are multiplexed with onboard peripherals and are not connected to TRAVEO™ T2G-B-H MCU by default. For detailed information on how to rework the kit to access these pins, see Table 3 .
27.	CAN FD transceiver (U8)	CAN FD transceiver.
28.	CAN FD interface connector (J5)	Connector to connect the kit to the CAN / CAN FD network
29.	User buttons (SW4)	Provide input to TRAVEO™ T2G-B-H MCU. Note that by default the button connects the TRAVEO™ T2G-B-H MCU pin to the ground when pressed, so you need to configure the TRAVEO™ T2G-B-H MCU pin as a digital input with resistive pull-up for detecting the button press.
30.	User buttons (SW3)	Provide input to TRAVEO™ T2G-B-H MCU. Note that by default the button connects the TRAVEO™ T2G-B-H MCU pin to the ground when pressed, so you need to configure the TRAVEO™ T2G-B-H MCU pin as a digital input with resistive pull-up for detecting the button press.

Kit operation

Sl. No.	Peripheral	Description
31.	T2G-B-H reset button (SW2)	Resets TRAVEO™ T2G-B-H MCU. It connects the TRAVEO™ T2G-B-H MCU reset (XRES) pin to the ground.
32.	25-MHz crystal for Ethernet transceiver (Y3)	Oscillator for the Ethernet PHY.

See [4.4 Layouts](#) for details on various hardware blocks.

3.2 BSP selection

The TRAVEO™ T2G-B-H evaluation kit comes with a KIT_T2G-B-H_Lite board support package (BSP) to build and run code examples on the kit by following the instructions given in the **Board Support Packages** section of the [ModusToolbox™ user guide](#).

3.3 KitProg3: Onboard programmer/debugger

The TRAVEO™ T2G-B-H evaluation board can be programmed and debugged using the onboard KitProg3, which has USB-UART, USB-I2C, and USB-SPI Bridge (not supported on this board) functionality. KitProg3 supports CMSIS-DAP only and does not support mass storage. A PSoC™ 5LP device is used to implement the KitProg3 functionality. For more details on the KitProg3 functionality, see the [KitProg3 user guide](#).

3.3.1 Programming and debugging using ModusToolbox™ software

1. Connect the board to the PC using the provided USB cable through the KitProg3 USB connector, as shown in [Figure 7](#). It enumerates as a USB Composite Device when you connect it to your PC for the first time.
2. KitProg3 on this kit supports CMSIS-DAP Bulk mode (default) and CMSIS-DAP Bulk with two UARTs. The status LED (amber) is always ON in the CMSIS-DAP Bulk mode. If you do not see the desired LED status, see the [KitProg3 user guide](#) for details on the KitProg3 status and troubleshooting instructions.

Note: The programming can be done in either of the KitProg3 programming modes but it is recommended to program the kit in CMSIS-DAP Bulk mode.

Kit operation

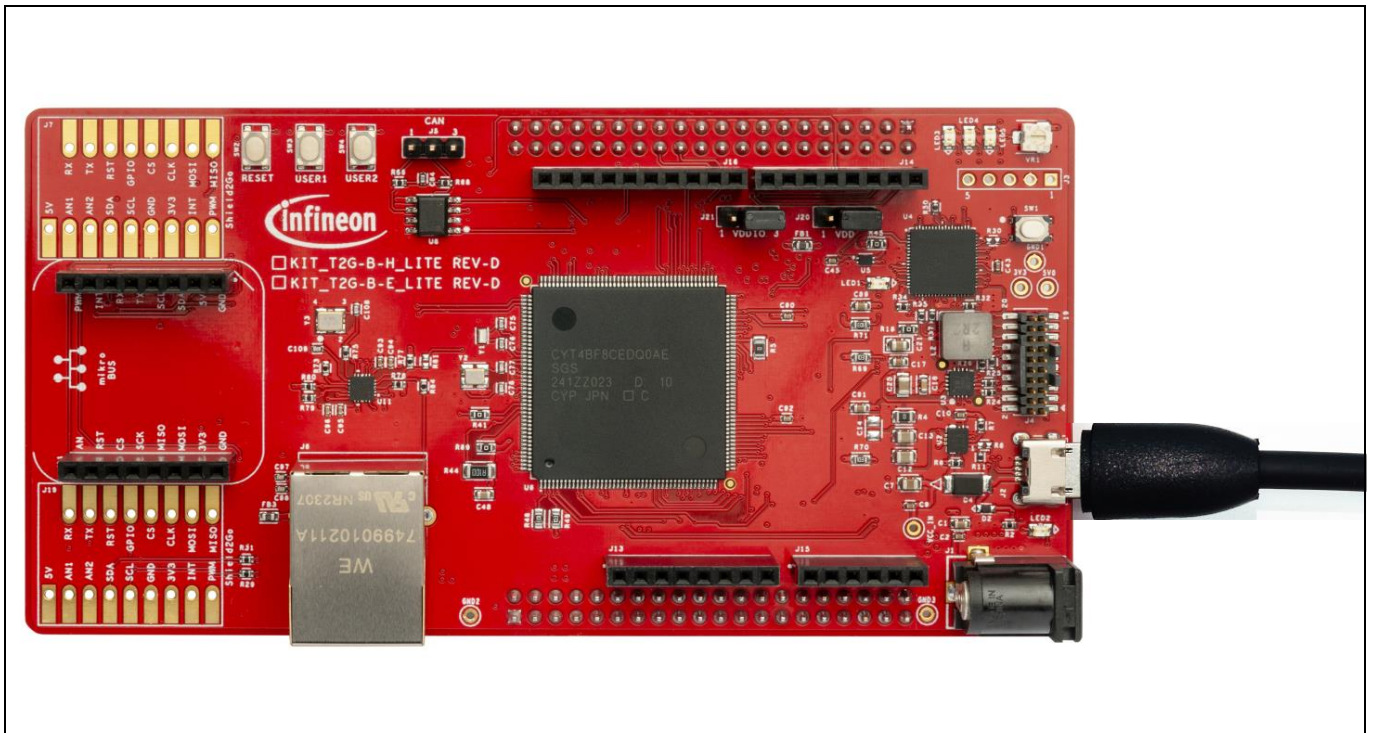

Figure 7 Connect USB cable to USB connector on the board

3. In the Eclipse IDE for ModusToolbox™ software, import the desired code example (application) into a new workspace.
 - a) Click on **New Application** from **Quick Panel**.

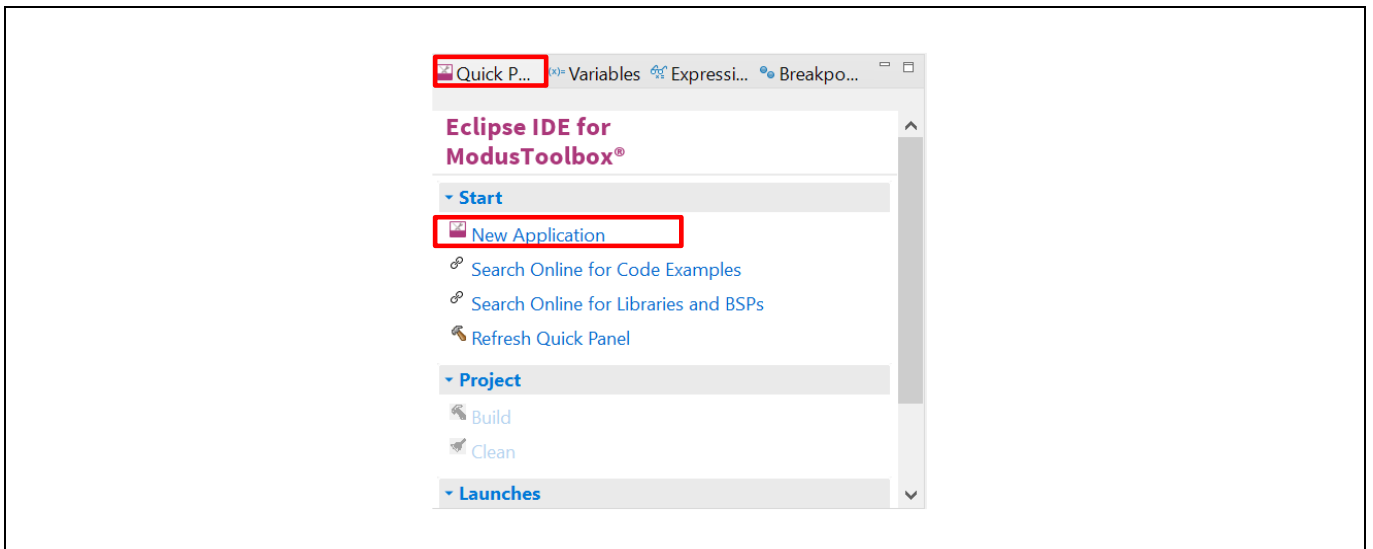

Figure 8 Create new application

Kit operation

- b) Select the BSP in the “Choose Board Support Package (BSP)” window and click **Next**.
 As noted in section 3.2 [BSP selection](#), select the BSP based on the combination of baseboard and radio module used. The rest of the steps assume there is no radio module connected to the baseboard and use the KIT_T2G-B-H_EVK BSP for the explanation.

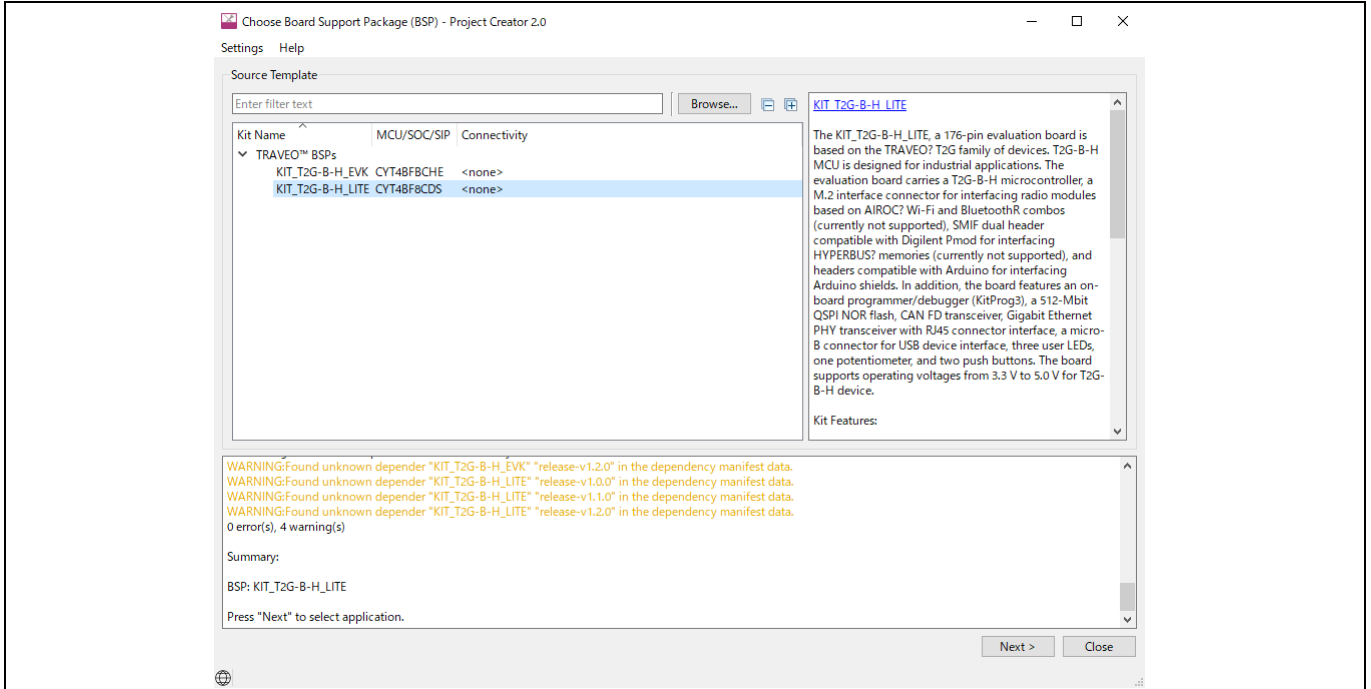

Figure 9 Creating a new application: Choose Board Support Package (BSP)

- c) Select the application in the “Select Application” window and click **Create**.

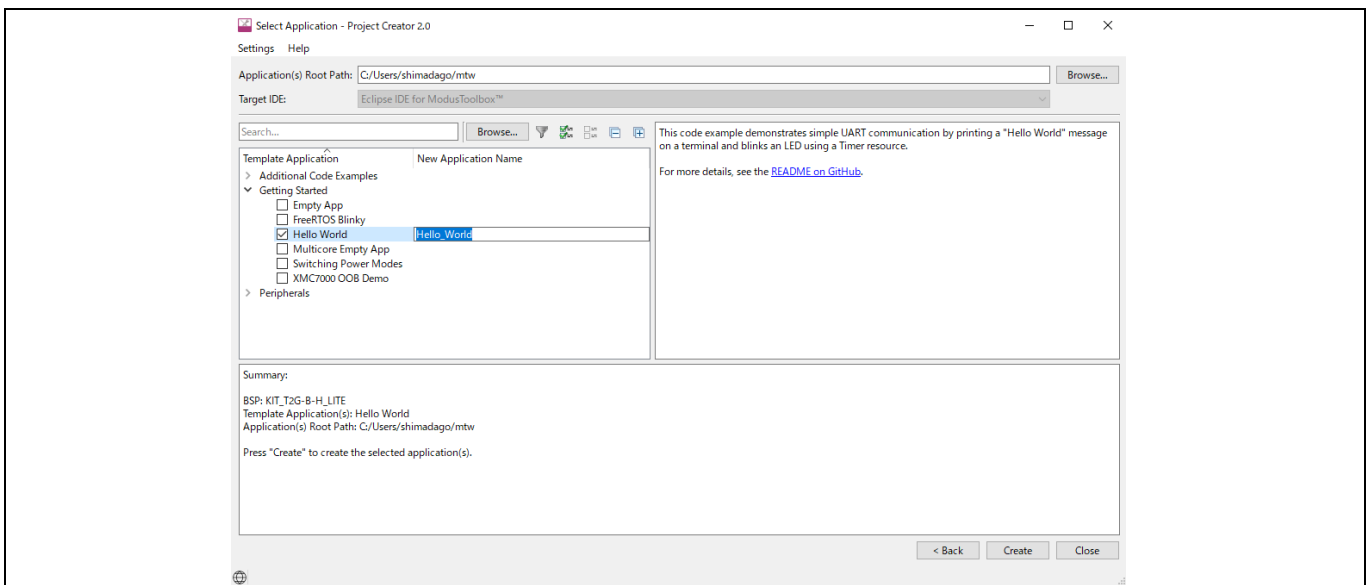

Figure 10 Creating a new application: Select application

Kit operation

- To build and program a TRAVEO™ T2G-B-H MCU application, in the Project Explorer, select **<App_Name>** project. In the Quick Panel, scroll to the Launches section and click the **<App_Name> Program (KitProg3_MiniProg4)** configuration as shown in [Figure 11](#).

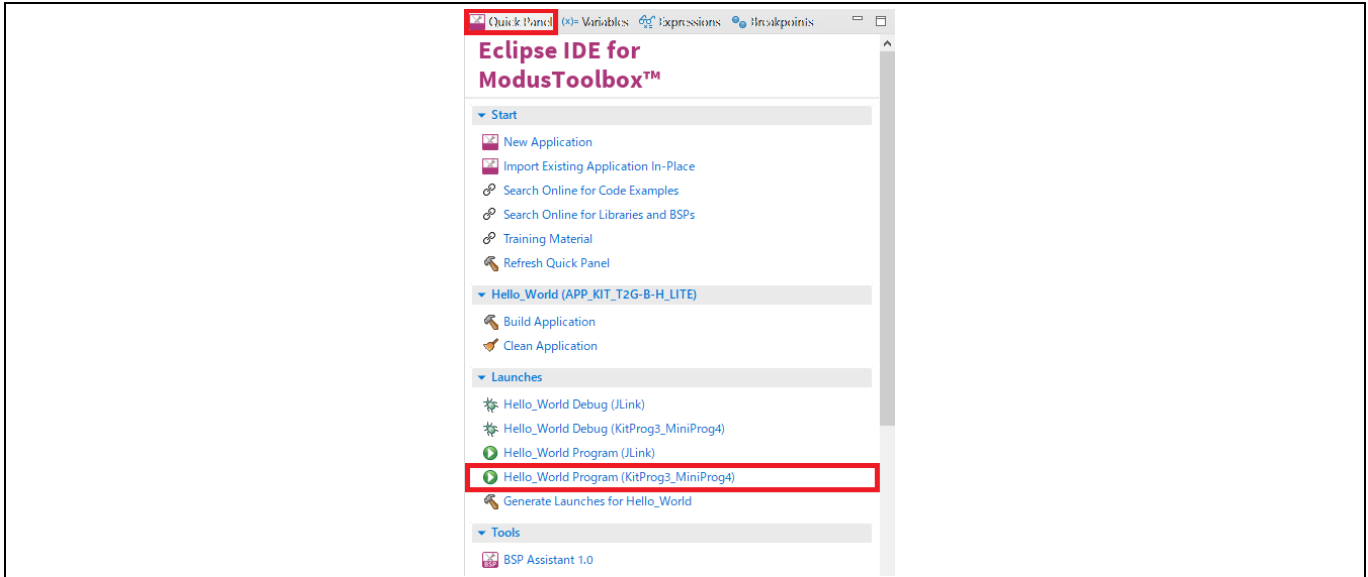

Figure 11 Programming in ModusToolbox™ software

- ModusToolbox™ software has an integrated debugger. To debug a TRAVEO™ T2G-B-H MCU application, in the Project Explorer, select **<App_Name>** project. In the Quick Panel, scroll to the **Launches** section and click the **<App_Name> Debug (KitProg3_MiniProg4)** configuration as shown in [Figure 12](#). For more details, see the “Program and debug” section in the [Eclipse IDE for ModusToolbox™ user guide](#).

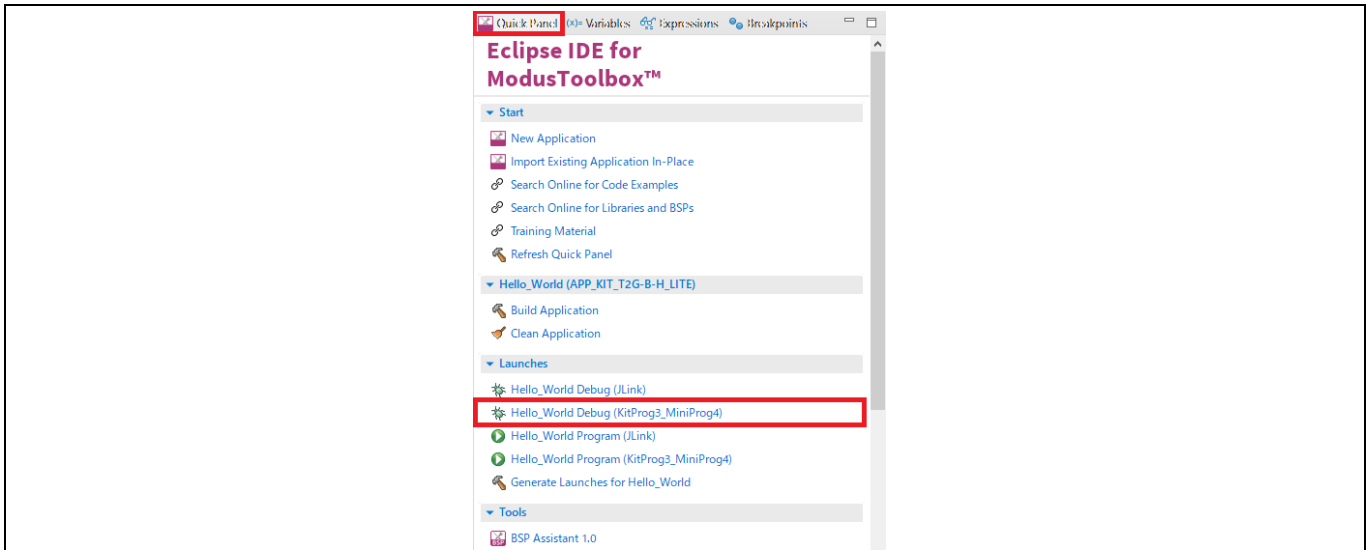

Figure 12 Debugging in ModusToolbox™ software

Kit operation

3.3.2 USB-UART bridge

KitProg3 on the TRAVEO™ T2G-B-H evaluation board can act as a USB-UART bridge.

The UART Rx and Tx pins of KitProg3 are connected to the TRAVEO™ T2G-B-H MCU UART pins as follows:

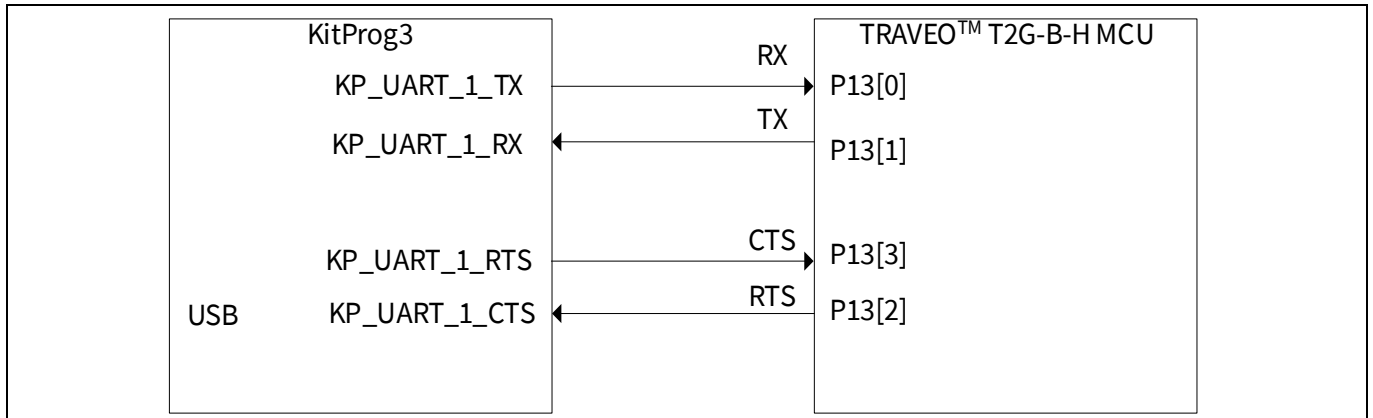

Figure 13 UART connection between KitProg3 and TRAVEO™ T2G-B-H MCU

For more details on the KitProg3 USB-UART functionality, see the [KitProg3 user guide](#).

Hardware

4 Hardware

4.1 KIT_T2G-B-H_Lite kit connections

4.1.1 USER LEDs

The correspondence between the LEDs on the board and the CYT4BF8xx device pins and the port pins are shown in [Table 5](#).

Table 5 USER LEDs

USER LED	Ref. Designator	CYT4BF8xx	
		Pin	Pin
USER LED 1	LED3	29	P5.0
USER LED 2	LED4	30	P5.1
USER LED 3	LED5	31	P5.2

4.1.2 USER switches

The correspondence between the switches and the CYT4BF8xx device pins and the port pins are shown in [Table 6](#).

Table 6 USER switches

USER switch	Ref. Designator	CYT4BF8xx	
		Pin	Pin
USER SW 1	SW3	32	P5.3
USER SW 2	SW4	116	P17.0

4.1.3 RESET switch

The correspondence between the RESET switch and the CYT4BF8xx device pin and the port pin are shown in [Table 7](#).

Table 7 RESET switch

USER switch	Ref. Designator	CYT4BF8xx	
		Pin	Pin
RESET SW	SW2	152	XRES

Hardware

4.1.4 MODE switch

The mode switch will change the mode of operation of the KitProg3 device. While communicating with the TRAVEO™ T2G device, make sure that the KitProg3 device should be in CMSIS DAP mode (LED1 is solid ON).

The correspondence between the MODE SW and the PSoC™ 5LP pin number is given in [Table 8](#).

Table 8 MODE switch

USER switch	Ref. Designator	PSoC 5LP	
		Pin	Pin
MODE SW	SW1	13	P1[2]

4.2 System configuration

To work with the starter kit, install the KitProg3 USB-UART driver in the system; see the [KitProg3 User Guide](#).

For software and tool configuration, see the [TRAVEO™ T2G Body High Lite Kit - Getting Started](#).

4.3 Schematics

This section shows the schematics of the TRAVEO™ T2G Body High Lite Kit.

General safety instructions

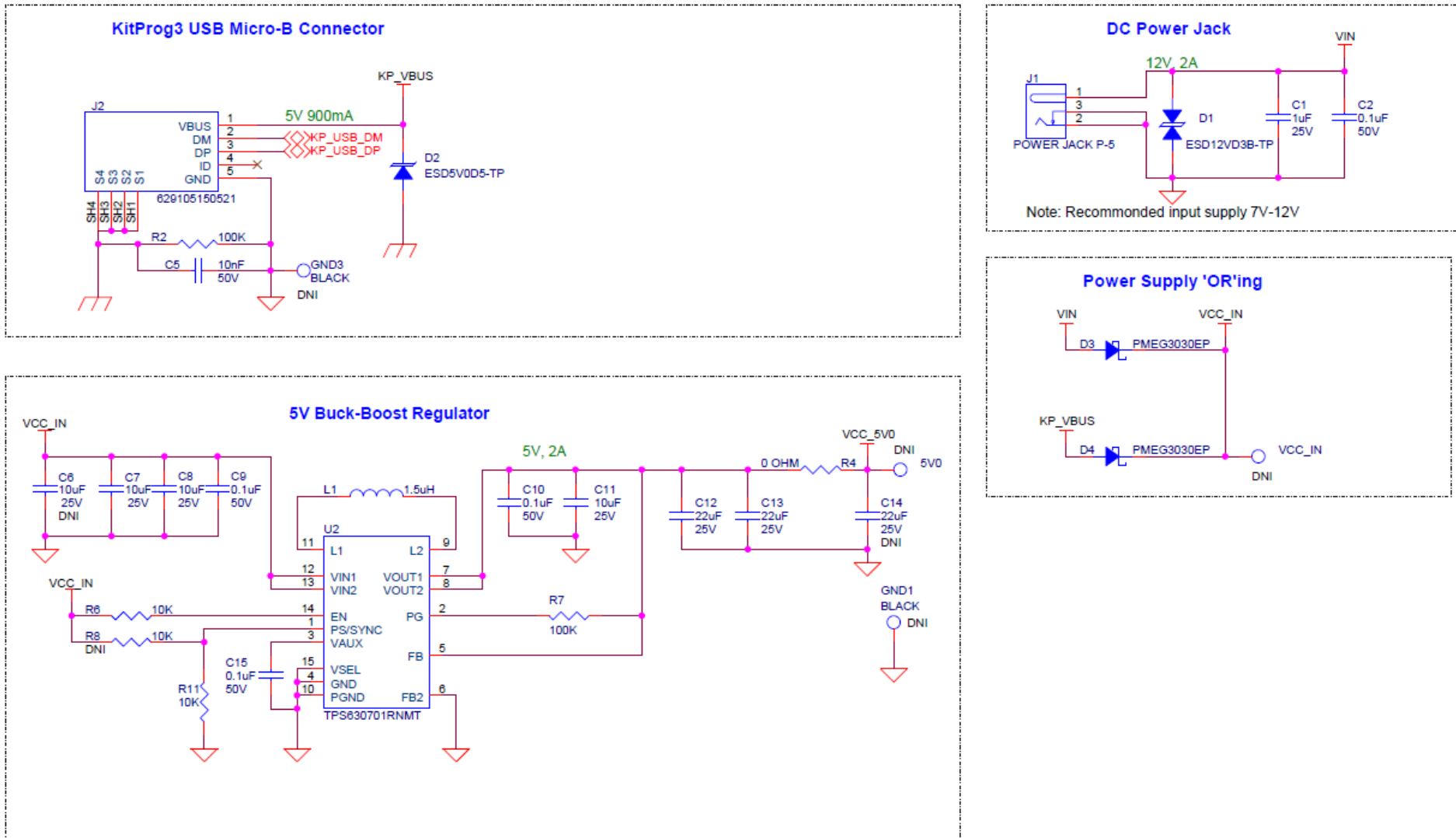

Figure 14 Power Supply - 1

General safety instructions

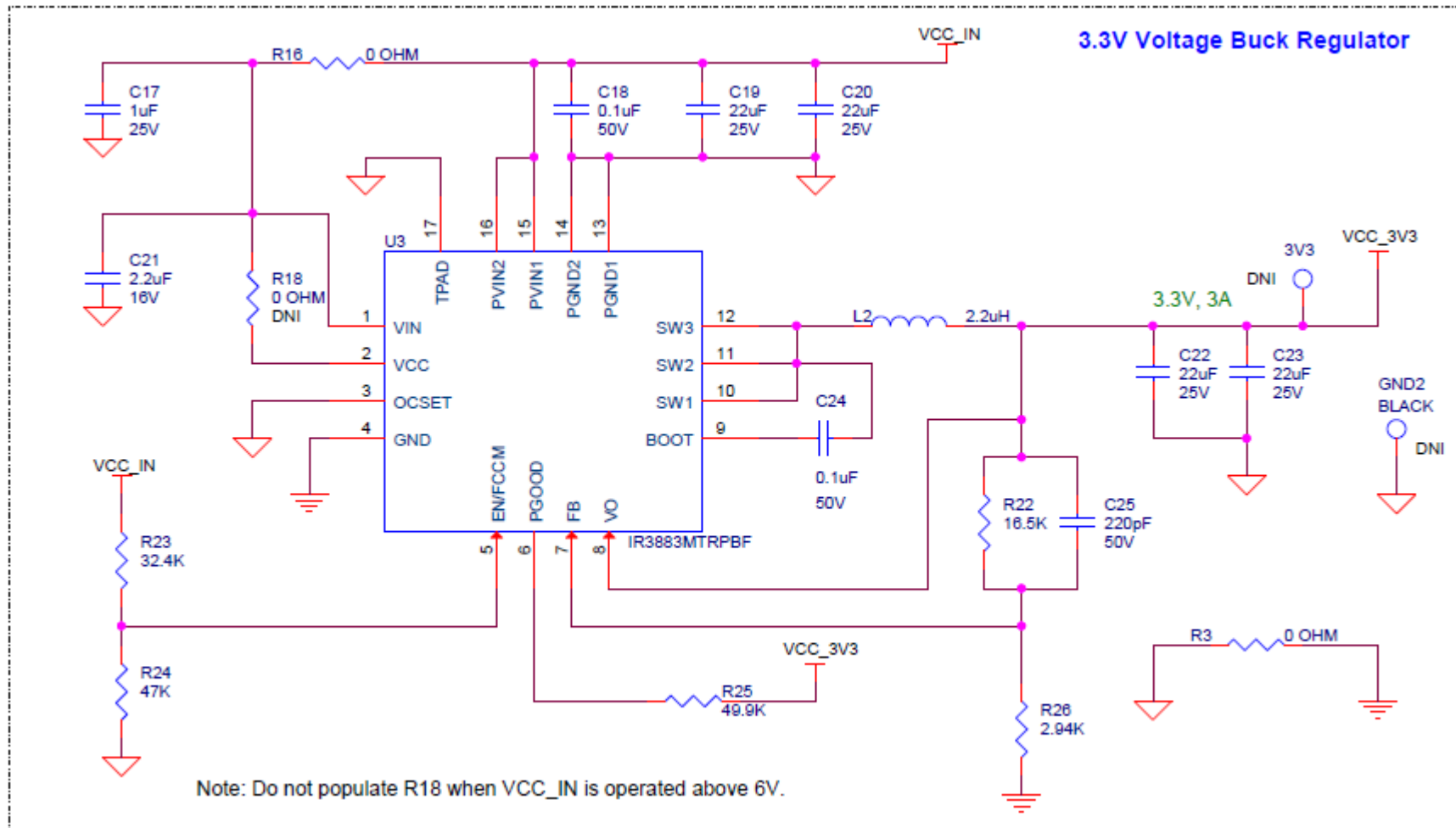

Figure 15 Power Supply - 2

General safety instructions

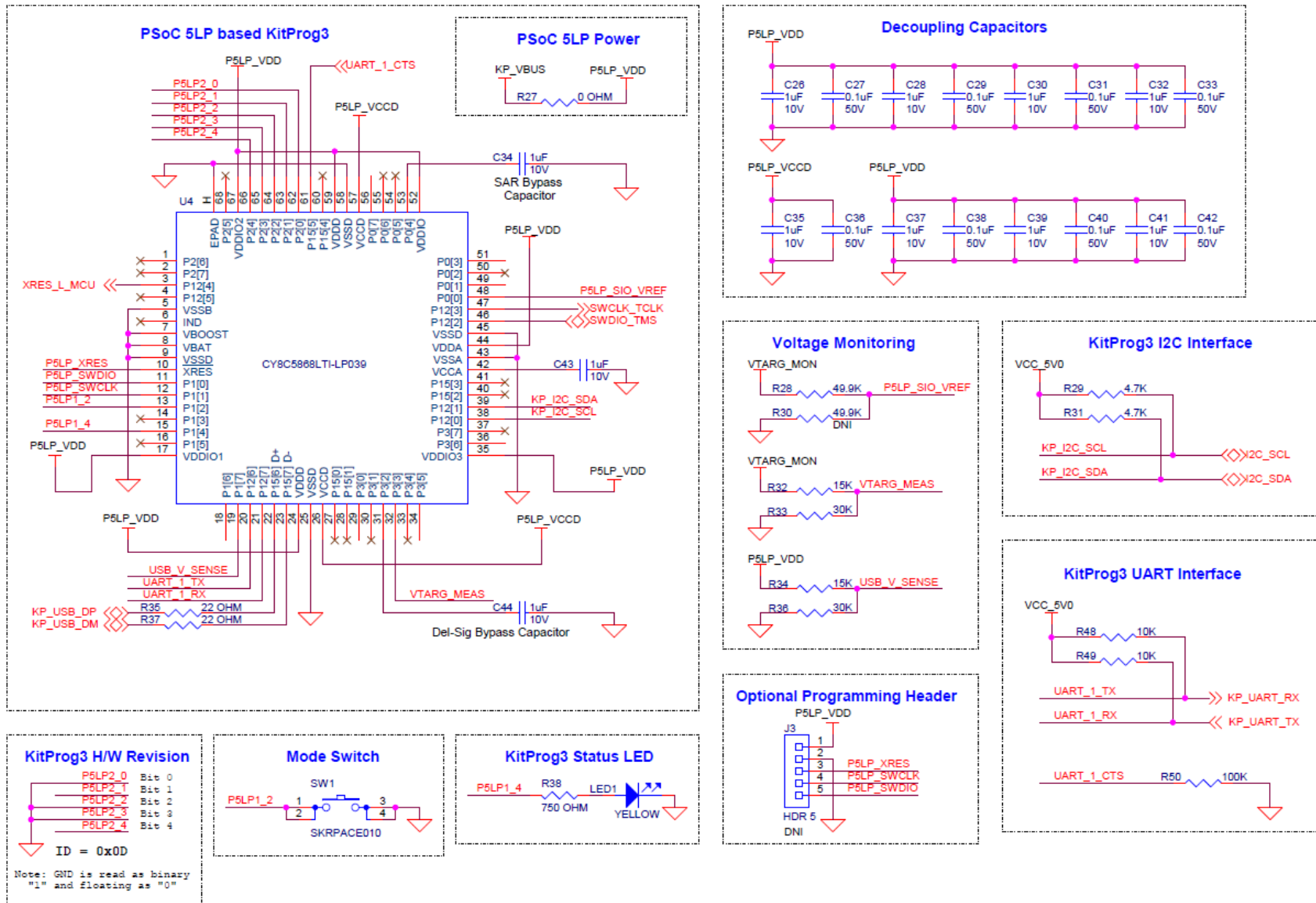

Figure 16 KitProg3 Interface

General safety instructions

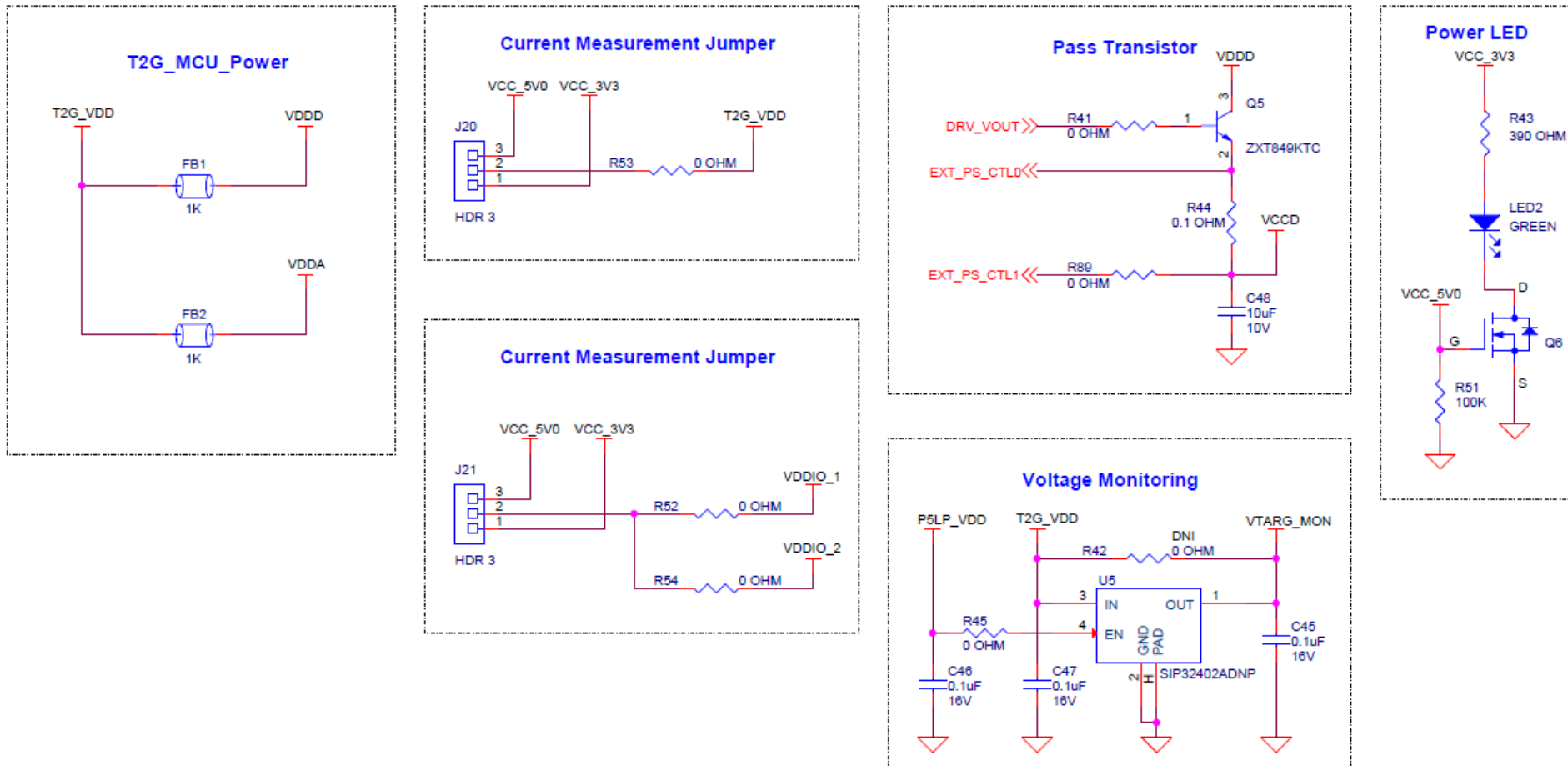

Figure 17 TRAVEO T2G MCU Power

General safety instructions

T2G-B-H-8M 176 MCU1



Figure 18 TRAVEO™ T2G-B-H-8M 176-pin MCU - 1

General safety instructions

T2G-B-H-8M 176 MCU2

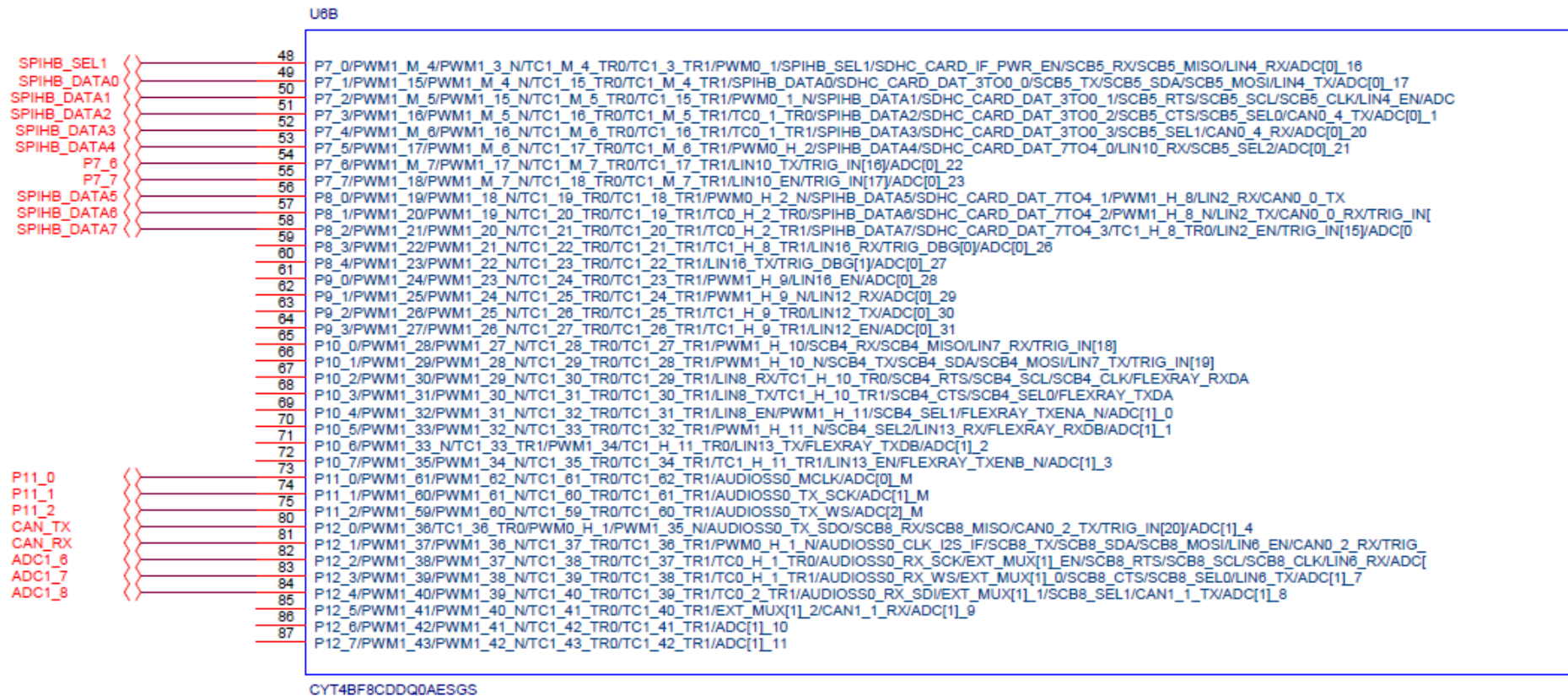

Figure 19 TRAVEO T2G-B-H-8M 176-pin MCU - 2

General safety instructions

T2G-B-H-8M 176 MCU3



Figure 20 TRAVEO T2G-B-H-8M 176-pin MCU - 3

General safety instructions

T2G-B-H-8M 176 MCU4



Figure 21 TRAVEO T2G-B-H-8M 176-pin MCU - 4

General safety instructions

T2G-B-H-8M 176 MCU5

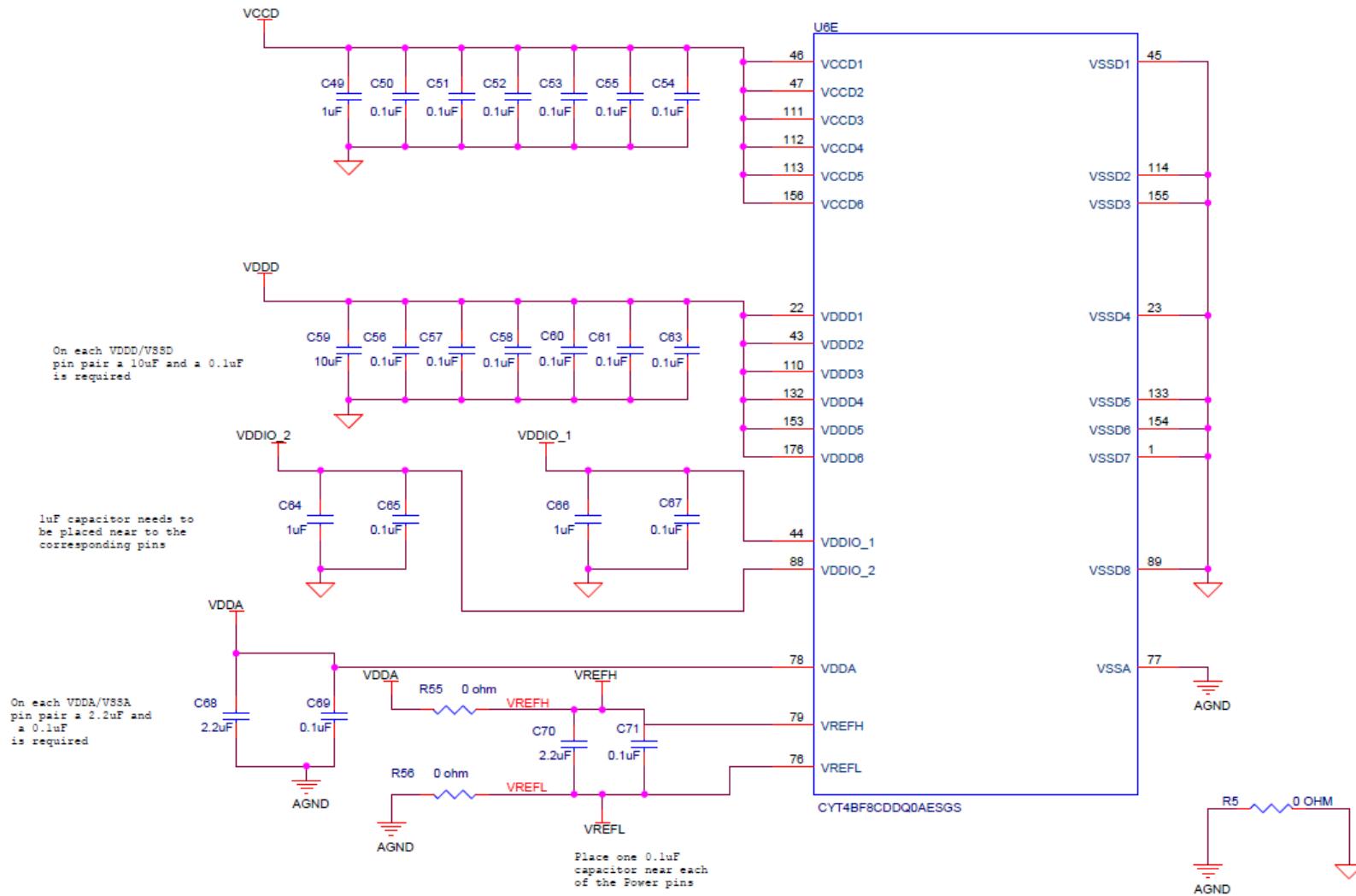

Figure 22 TRAVEO T2G-B-H-8M 176-pin MCU - 5

General safety instructions

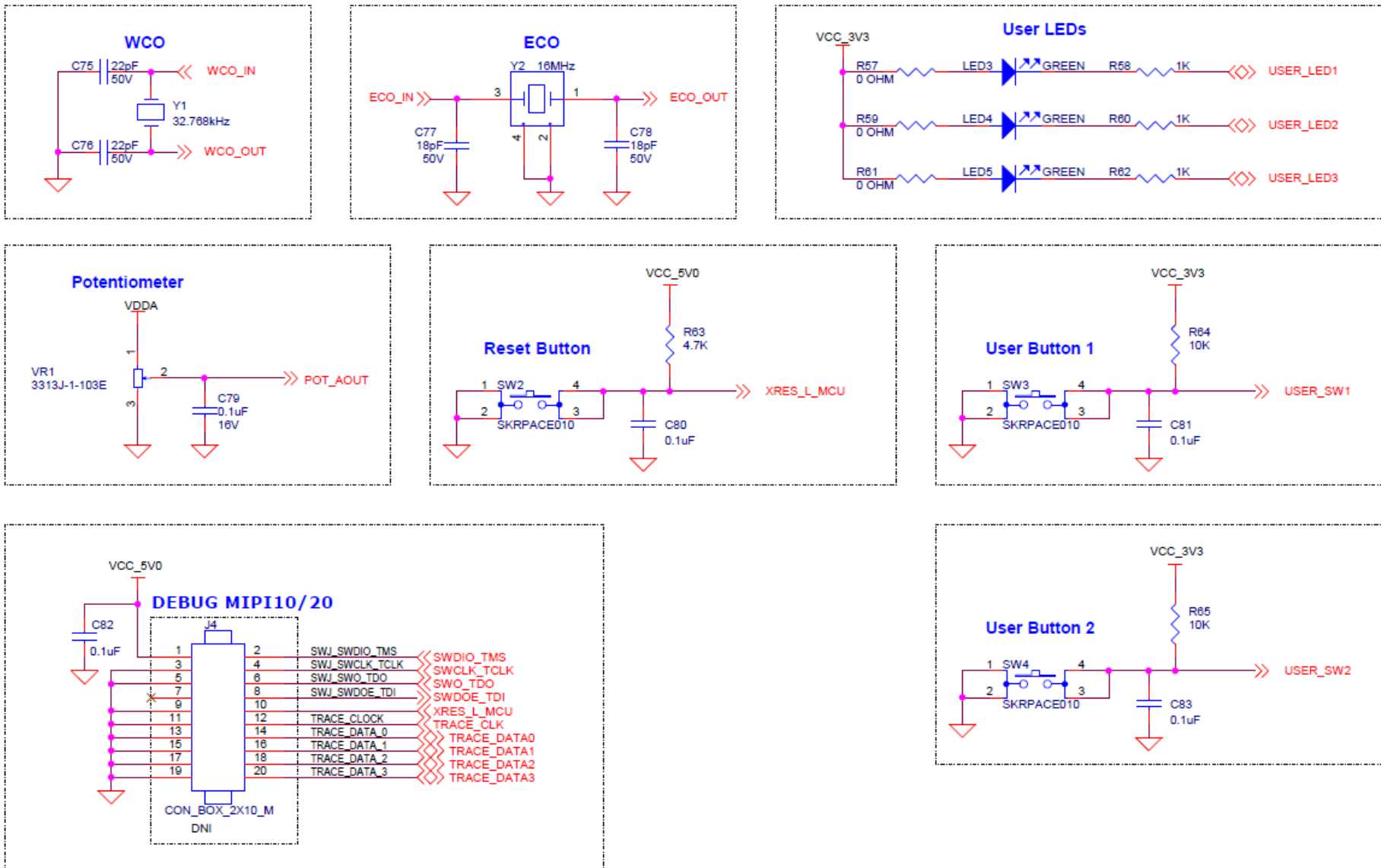

Figure 23 Peripheral Interface

General safety instructions

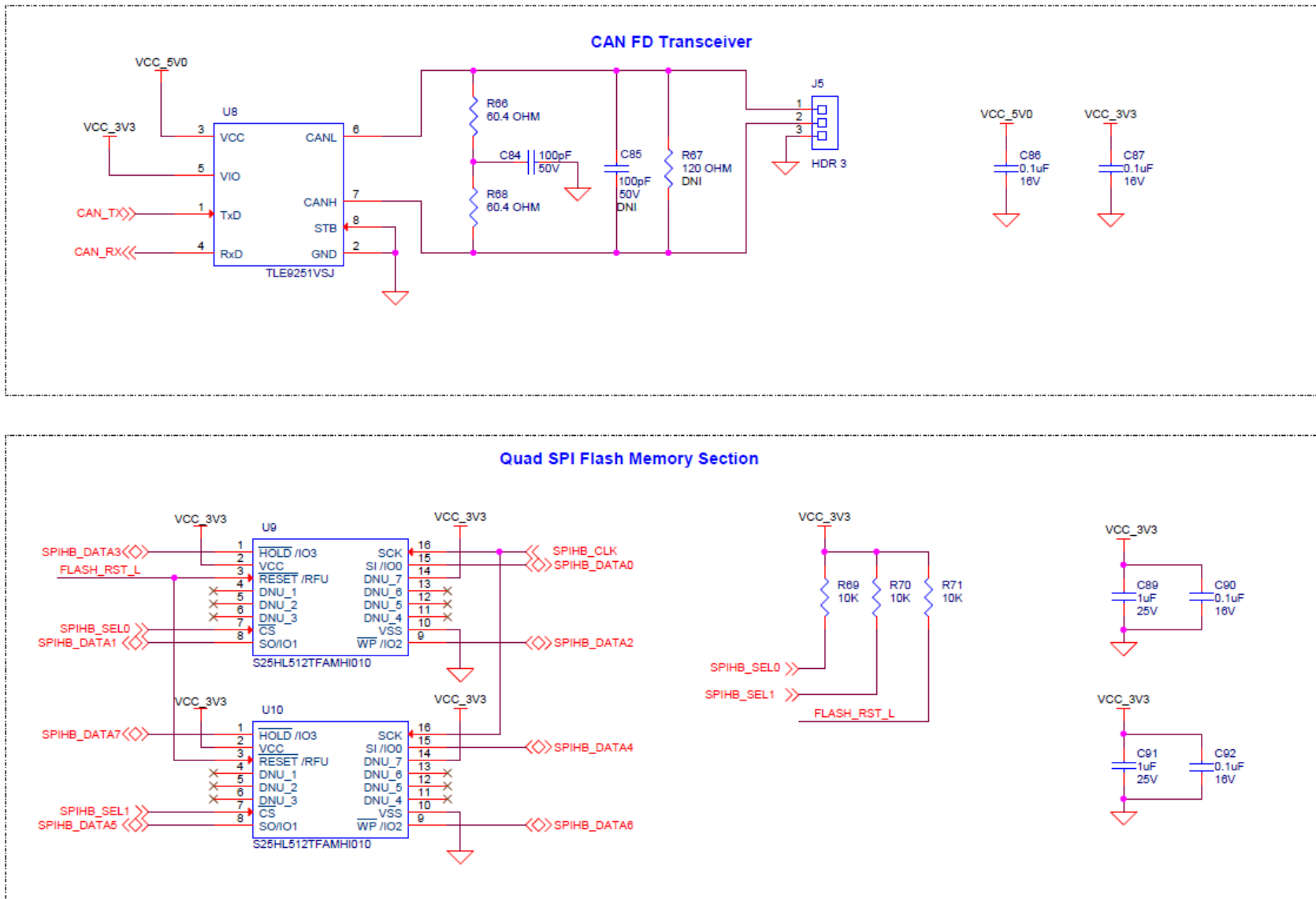

Figure 24 CAN and QSPI Interface

General safety instructions

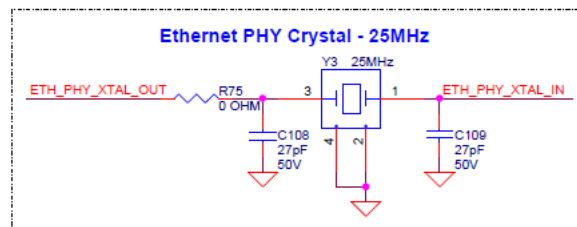
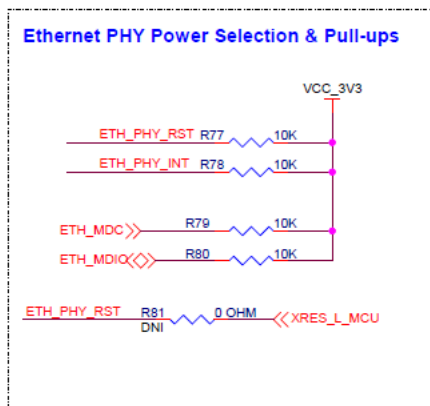
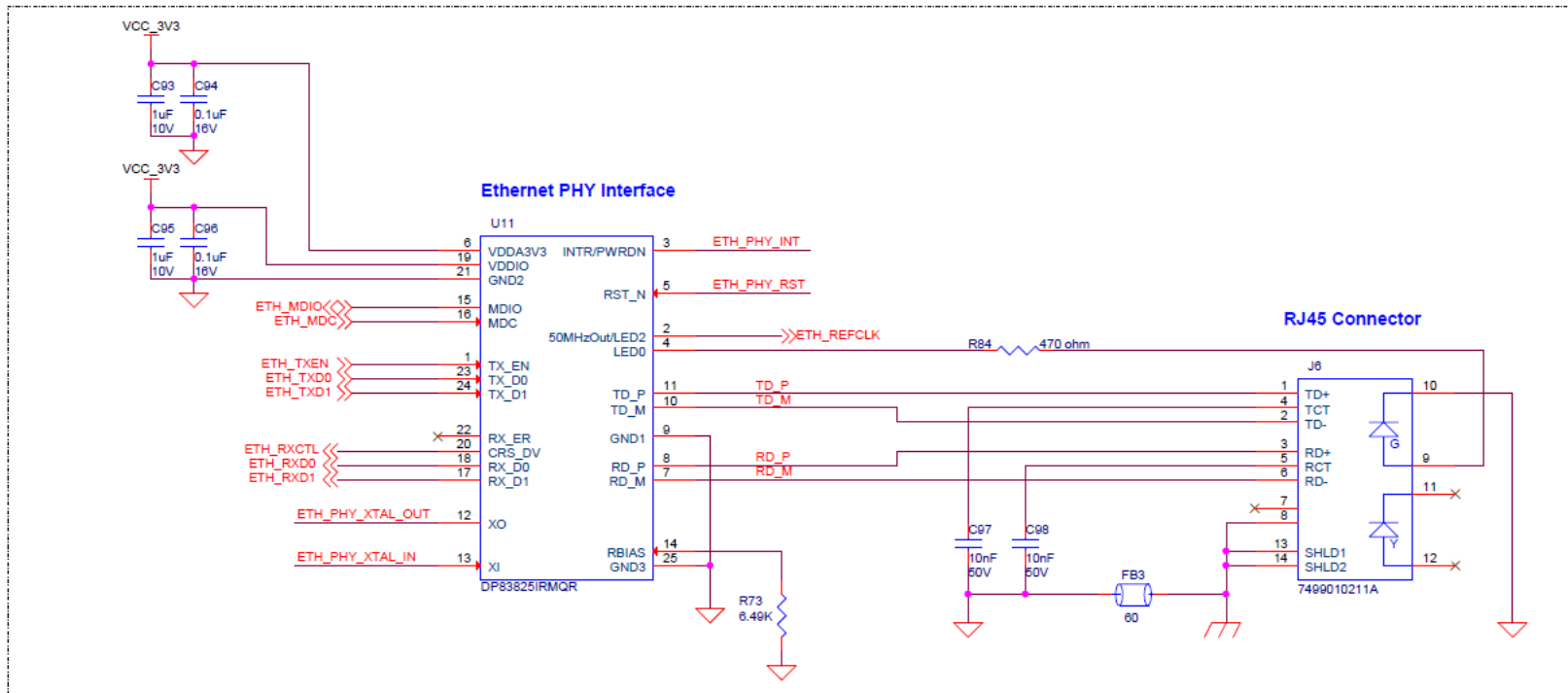

Figure 25 Ethernet Transceiver

General safety instructions

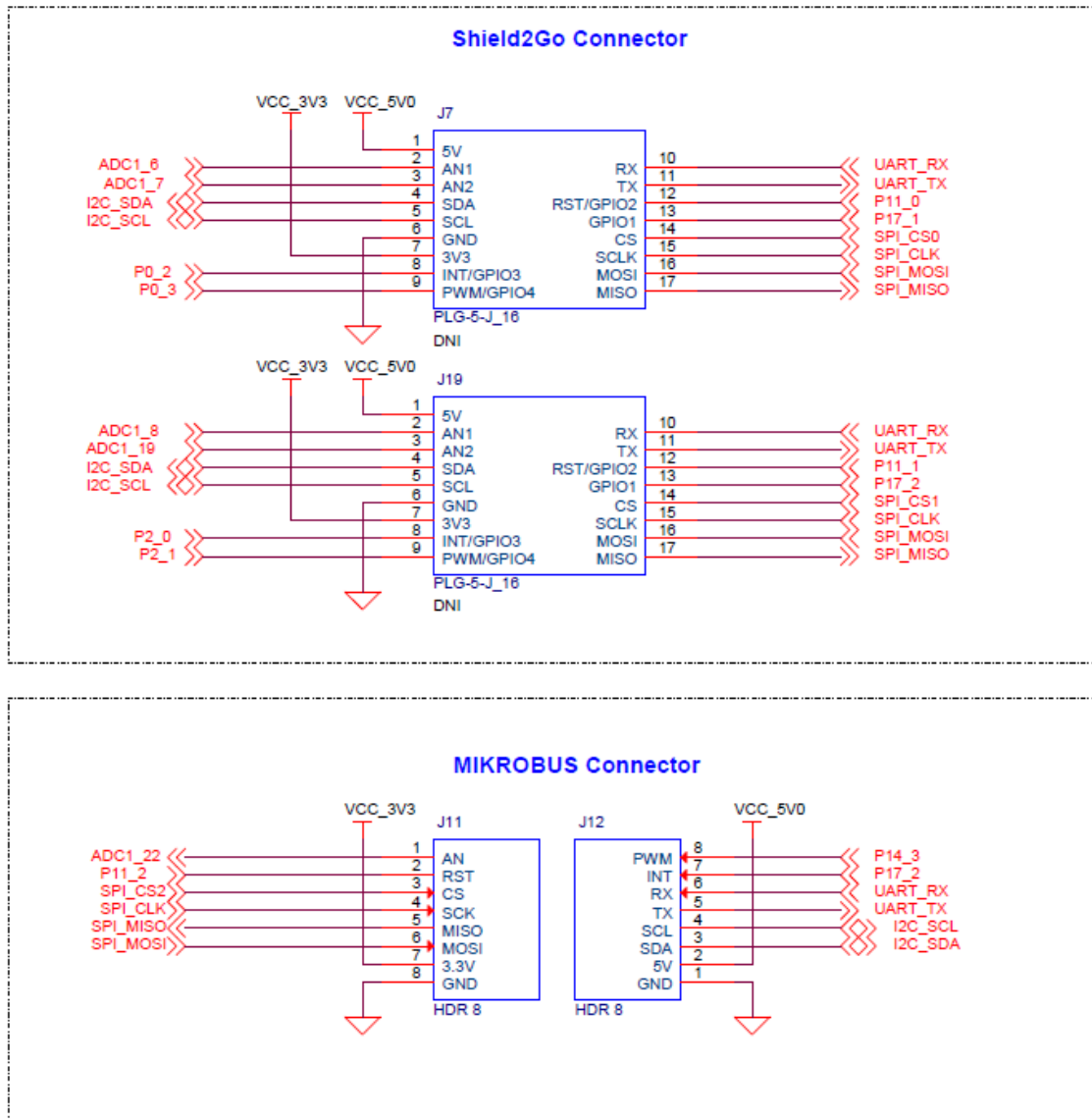

Figure 26 Ethernet Clock and RJ45 Connector

General safety instructions

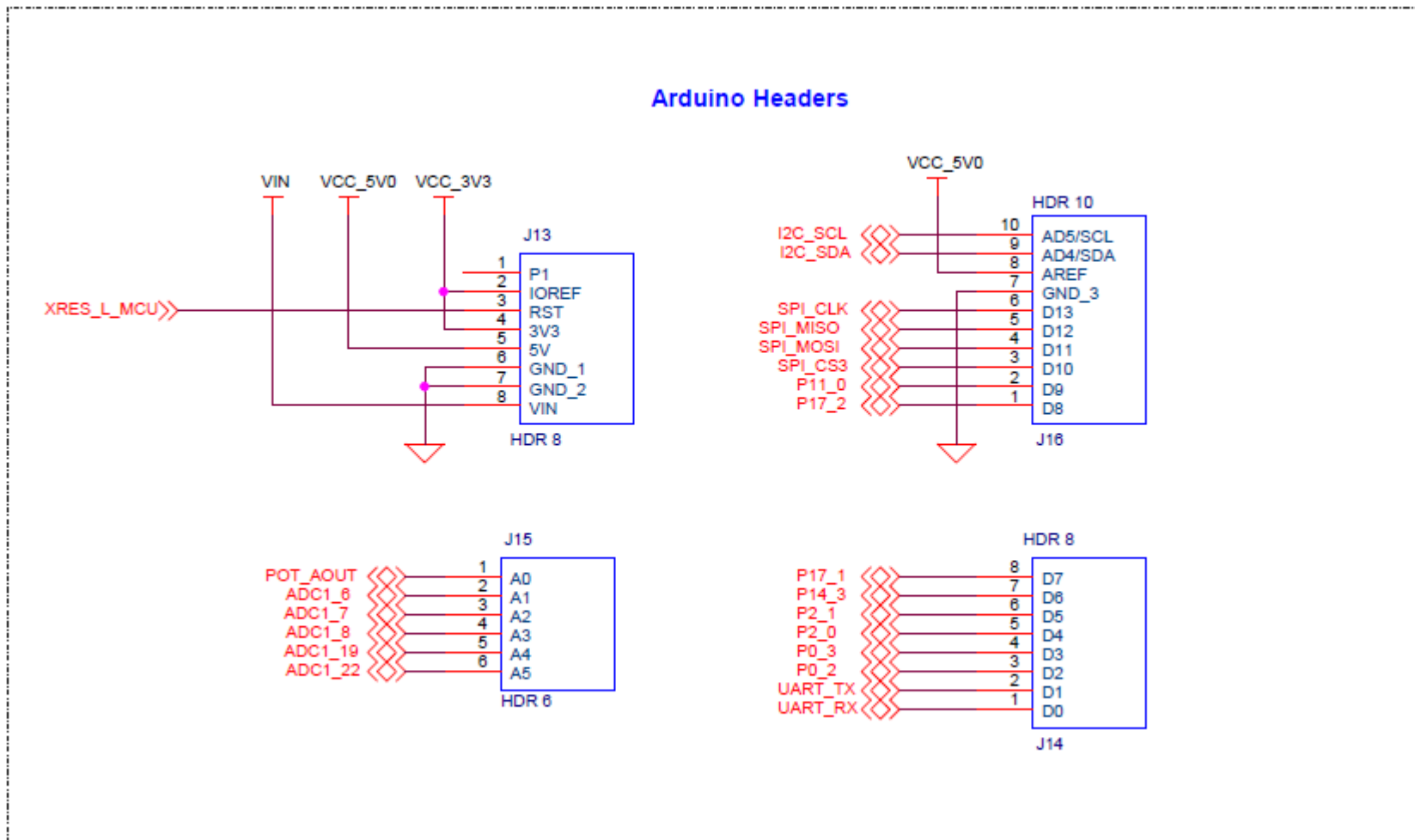

Figure 27 Ethernet Clock and RJ45 Connector

Expansion Headers

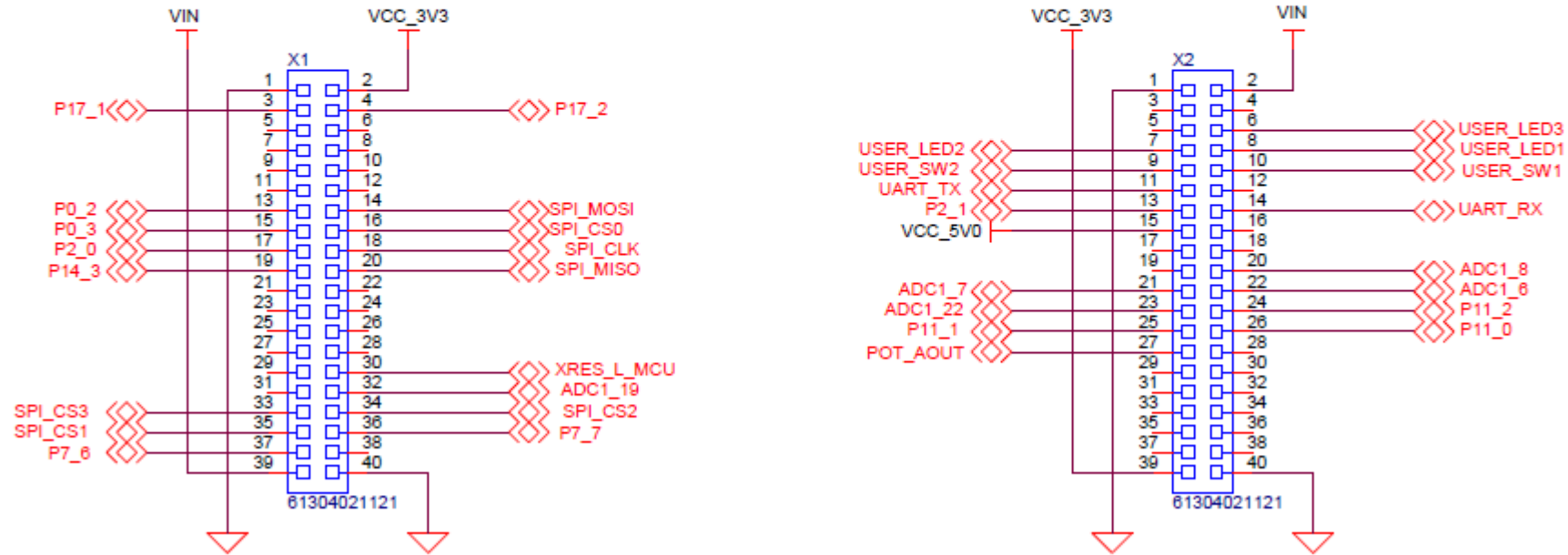

Figure 28 Shield2Go /MikroBUS

General safety instructions

4.4 Layouts

This section shows the board layouts of the TRAVEO T2G Body High Lite kit.

5 Known limitations

This section lists the known limitations of the KIT_T2G-B-H_LITE.

Table 9 Limitation information

No.	Description	Workaround	Application
1	Power supply from the DC power jack does not work.	Do not use DC 12-V AC adaptor plugged to the DC Power Jack (J1).	Rev. D version.

Revision history**Revision history**

Document revision	Date	Description of changes
**	2023-07-20	Initial release
*A	2023-10-19	Added a note about schematics. Fixed pinout Figure 3 and fixed schematics

Trademarks

All referenced product or service names and trademarks are the property of their respective owners.

Edition 2023-10-19

Published by

Infineon Technologies AG
81726 Munich, Germany

© 2023 Infineon Technologies AG.
All Rights Reserved.

Do you have a question about this document?

Email: erratum@infineon.com

Document reference

002-37237 Rev. *A

Important notice

The information given in this document shall in no event be regarded as a guarantee of conditions or characteristics ("Beschaffheitsgarantie")

With respect to any examples, hints or any typical values stated herein and/or any information regarding the application of the product, Infineon Technologies hereby disclaims any and all warranties and liabilities of any kind, including without limitation warranties of non-infringement of intellectual property rights of any third party.

In addition, any information given in this document is subject to customer's compliance with its obligations stated in this document and any applicable legal requirements, norms and standards concerning customer's products and any use of the product of Infineon Technologies in customer's applications.

The data contained in this document is exclusively intended for technically trained staff. It is the responsibility of customer's technical departments to evaluate the suitability of the product for the intended application and the completeness of the product information given in this document with respect to such application.

Warnings

Due to technical requirements products may contain dangerous substances. For information on the types in question please contact your nearest Infineon Technologies office.

Except as otherwise explicitly approved by Infineon Technologies in a written document signed by authorized representatives of Infineon Technologies, Infineon Technologies' products may not be used in any applications where a failure of the product or any consequences of the use thereof can reasonably be expected to result in personal injury.

X-ON Electronics

Largest Supplier of Electrical and Electronic Components

Click to view similar products for [Development Boards & Kits - ARM category](#):

Click to view products by [Infineon manufacturer](#):

Other Similar products are found below :

[CY4541](#) [OM13090UL](#) [YR0K77210B000BE](#) [B-U585I-IOT02A](#) [NUCLEO-WL55JC1](#) [ZDSD-Pinboard](#) [LKS32MC034DOF6Q8-k](#)
[LKS32MC077MBS8-K](#) [LKS32MC038Y6P8B-K](#) [LKS32MC071DOC8T8-K](#) [LKS32MC074DOF8Q8-K](#) [LKS32MC071CBT8-K](#)
[LKS32MC038Y6P8-k](#) [Ai-WB2-32S-Kit](#) [GD32E103T-START](#) [GD32L233K-START](#) [XDS601](#) [RP2040-Tiny](#) [M6G2C-256LI](#) [YT37](#)
[LKS32MC033H6P8B-K](#) [VC-02-Kit_EN](#) [Ra-08H-Kit](#) [Hi-12FL-Kit](#) [PB-03M-Kit](#) [Ai-WB2-13-Kit](#) [PB-03F-Kit](#) [Ra-08-Kit](#) [Hi-07SL-Kit](#) [Hi-](#)
[07S-Kit](#) [Ai-WB2-12F-Kit](#) [PB-03-Kit](#) [Hi-12F-Kit](#) [AT-START-F407](#) [E104-BT40-TB](#) [APM32F072VBT6](#) [APM32F091VC MINI](#)
[APM32F407IG-MINIBOARD](#) [APM32F051R8 MINI](#) [GD32FPRT-START](#) [GD32407H-START-1](#) [GD32E503V-EVAL](#) [GD32E507R-START](#)
[GD32403V-START-1](#) [EPC1EVK-ECGPPG\(FS\)](#) [NS4EVKA-LC](#) [ENS1EVKD](#) [.ENS1EVKB](#) [ENS1EVKE](#) [HLK-7621-ALL-SUIT](#)