

XMC1400 CPU Card

For XMC1000 Family

CPU-14B-V1

XMC1400 CPU Card

Board User's Manual

Revision 2.0, 2019-09-16

Microcontroller

Edition 2019-09-16

**Published by
Infineon Technologies AG
81726 Munich, Germany**

**© 2019 Infineon Technologies AG
All Rights Reserved.**

Legal Disclaimer

The information given in this document shall in no event be regarded as a guarantee of conditions or characteristics. With respect to any examples or hints given herein, any typical values stated herein and/or any information regarding the application of the device, Infineon Technologies hereby disclaims any and all warranties and liabilities of any kind, including without limitation, warranties of non-infringement of intellectual property rights of any third party.

Information

For further information on technology, delivery terms and conditions and prices, please contact the nearest Infineon Technologies Office (www.infineon.com).

Warnings

Due to technical requirements, components may contain dangerous substances. For information on the types in question, please contact the nearest Infineon Technologies Office.

Infineon Technologies components may be used in life-support devices or systems only with the express written approval of Infineon Technologies, if a failure of such components can reasonably be expected to cause the failure of that life-support device or system or to affect the safety or effectiveness of that device or system. Life support devices or systems are intended to be implanted in the human body or to support and/or maintain and sustain and/or protect human life. If they fail, it is reasonable to assume that the health of the user or other persons may be endangered.



Revision History

Page or Item	Subjects (major changes since previous revision)
--------------	--

Revision 2.0, 2019-09-16

16,18	Change C210 to 4.7uF
-------	----------------------

Trademarks of Infineon Technologies AG

AURIX™, C166™, CanPAK™, CIPOST™, CIPURSET™, EconoPACK™, CoolMOST™, CoolSET™, CORECONTROL™, CROSSAVET™, DAVET™, DI-POL™, EasyPIM™, EconoBRIDGET™, EconoDUAL™, EconoPIM™, EconoPACK™, EiceDRIVERT™, eupec™, FCOST™, HITFET™, HybridPACK™, I²RFT™, ISOFACT™, IsoPACK™, MIPAQ™, ModSTACK™, my-d™, NovalithICT™, OptiMOST™, ORIGAT™, POWERCODE™, PRIMARION™, PrimePACK™, PrimeSTACK™, PRO-SILT™, PROFET™, RASICT™, ReverSave™, SatRICT™, SIEGET™, SINDRION™, SIPMOST™, SmartLEWIST™, SOLID FLASHT™, TEMPFET™, thinQ!™, TRENCHSTOPT™, TriCore™.

Other Trademarks

Advance Design System™ (ADS) of Agilent Technologies, AMBAT™, ARMT™, MULTI-ICET™, KEILT™, PRIMECELL™, REALVIEW™, THUMB™, µVision™ of ARM Limited, UK. AUTOSAR™ is licensed by AUTOSAR development partnership. Bluetooth™ of Bluetooth SIG Inc. CAT-iq™ of DECT Forum. COLOSSUST™, FirstGPST™ of Trimble Navigation Ltd. EMV™ of EMVCo, LLC (Visa Holdings Inc.). EPCOST™ of Epcos AG. FLEXGOT™ of Microsoft Corporation. FlexRay™ is licensed by FlexRay Consortium. HYPERTERMINAL™ of Hilgraeve Incorporated. IECT™ of Commission Electrotechnique Internationale. IrDAT™ of Infrared Data Association Corporation. ISOT™ of INTERNATIONAL ORGANIZATION FOR STANDARDIZATION. MATLAB™ of MathWorks, Inc. MAXIM™ of Maxim Integrated Products, Inc. MICROTECT™, NUCLEUST™ of Mentor Graphics Corporation. MIPIT™ of MIPI Alliance, Inc. MIPST™ of MIPS Technologies, Inc., USA. muRata™ of MURATA MANUFACTURING CO., MICROWAVE OFFICET™ (MWO) of Applied Wave Research Inc., OmniVision™ of OmniVision Technologies, Inc. Openwave™ Openwave Systems Inc. RED HAT™ Red Hat, Inc. RFMD™ RF Micro Devices, Inc. SIRIUST™ of Sirius Satellite Radio Inc. SOLARIST™ of Sun Microsystems, Inc. SPANSION™ of Spansion LLC Ltd. Symbian™ of Symbian Software Limited. TAIYO YUDENT™ of Taiyo Yuden Co. TEAKLITET™ of CEVA, Inc. TEKTRONIX™ of Tektronix Inc. TOKOT™ of TOKO KABUSHIKI KAISHA TA. UNIX™ of X/Open Company Limited. VERILOG™, PALLADIUM™ of Cadence Design Systems, Inc. VLYNQ™ of Texas Instruments Incorporated. VXWORKS™, WIND RIVERT™ of WIND RIVER SYSTEMS, INC. ZETEXT™ of Diodes Zetex Limited.

Last Trademarks Update 2011-11-11

Table of Contents

1	Overview	7
1.1	Key Features	7
1.2	Block Diagram	7
2	Hardware Description	8
2.1	XMC1400 connector for ARDUINO™	8
2.1.1	Digital IO connector	8
2.1.2	Analog input	10
2.1.3	Power connector, POWER	10
2.1.4	ICSP (In-Circuit Serial Programming) Header	11
2.2	LEDs	11
2.3	Other connectors	12
3	Production Data.....	14
3.1	Schematics	14
3.2	Layout and Geometry	17
3.3	Bill of Material	17

List of Figures

Figure 1	Block Diagram of XMC1400 CPU Card for Arduino™	7
Figure 2	XMC1400 CPU Card for Arduino™	8
Figure 3	Digital IO connectors IOH, IOL	9
Figure 4	Analog input AD connector	10
Figure 5	POWER connector	11
Figure 6	ICSP connector	11
Figure 7	LEDs Circuit	12
Figure 8	AD_AUX and AUX connector	12
Figure 9	Schematic 1 of 2 XMC1400 CPU Card for Arduino™	15
Figure 10	Schematic 2 of 2 XMC1400 CPU Card for Arduino™	16
Figure 11	XMC1400 CPU Card for Arduino™ layout and geometry	17

List of Tables

Table 1	Digital IO of connector IOH	9
Table 2	Digital IO of connector IOL	9
Table 3	Pinout of the AD connector	10
Table 4	Pinout of the POWER connector.....	11
Table 5	Signals of ICSP connector	11
Table 6	LEDs Signal Description	12
Table 7	Signals of connector AD_AUX	13
Table 8	Signals of connector AUX	13
Table 9	XMC1400 CPU Card for Arduino™.....	17

Introduction

This document describes the features and hardware details of the XMC1400 CPU Card for Arduino™. This board is mounted with ARM® Cortex™-M0 based XMC1400 Microcontroller from Infineon Technologies AG and part of Infineon's XMC1000 offering of Kits.

1 Overview

The XMC1400 CPU Card for Arduino™ has two rows of pin headers which fully compatible with Arduino™ shield. Hence, user can buy various Arduino shield boards off-the-shelf to test the capabilities of XMC1400 Microcontroller.

1.1 Key Features

The XMC1400 CPU Card for Arduino™ is equipped with the following features

- XMC1400 (ARM® Cortex™-M0 based) Microcontroller, TSSOP38
- Headers compatible with Arduino™ shield
- Detachable SEGGER J-Link debugger and UART virtual COM port, with micro USB connector
- Power supply concept compatible with Arduino™ Uno
- One LED as required from Arduino™ board specification and 2 additional LEDs
- XTAL (20MHz) and RTC_XTAL(32768Hz)

1.2 Block Diagram

Figure 1 shows the block diagram of the XMC1400 CPU Card for Arduino™. There are following blocks:

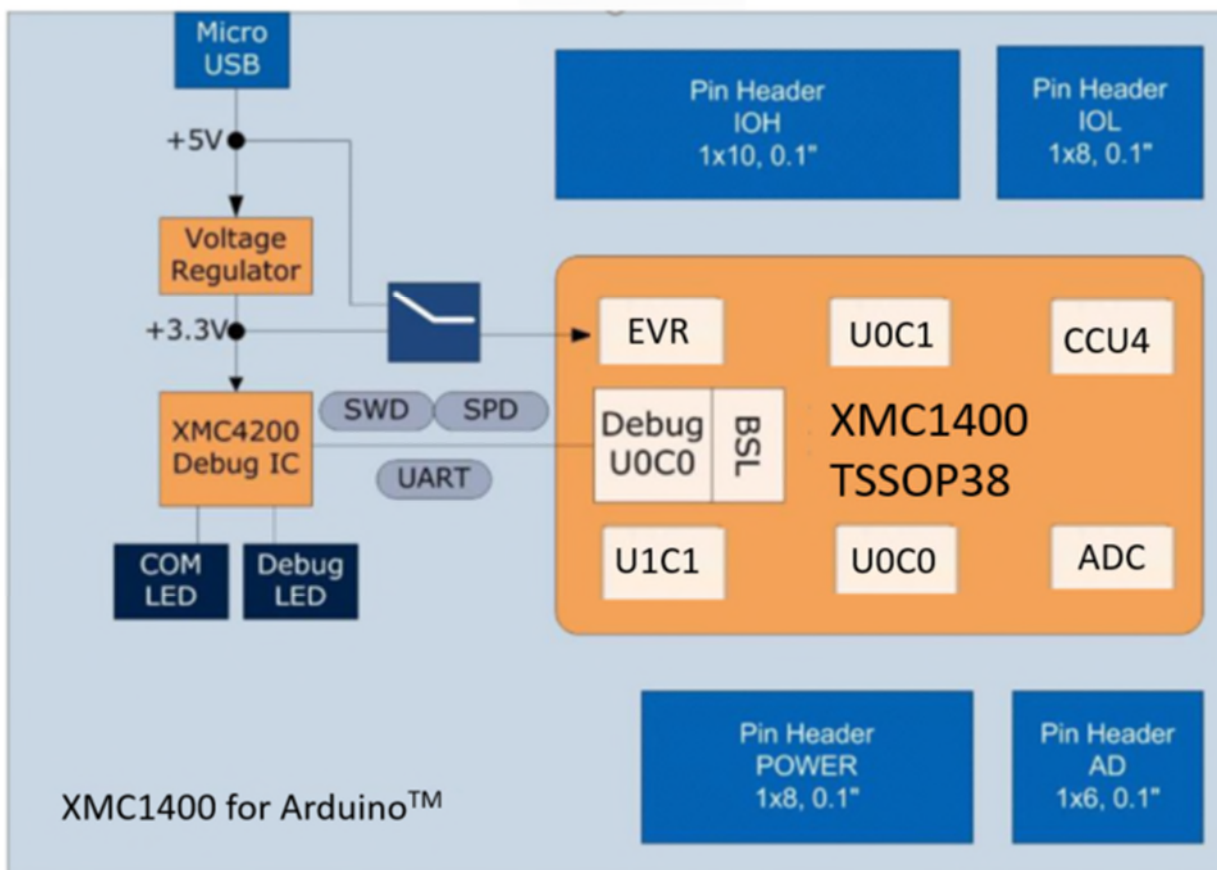

Figure 1 Block Diagram of XMC1400 CPU Card for Arduino™

2 Hardware Description

The following sections give a detailed description of the hardware and how it can be used.

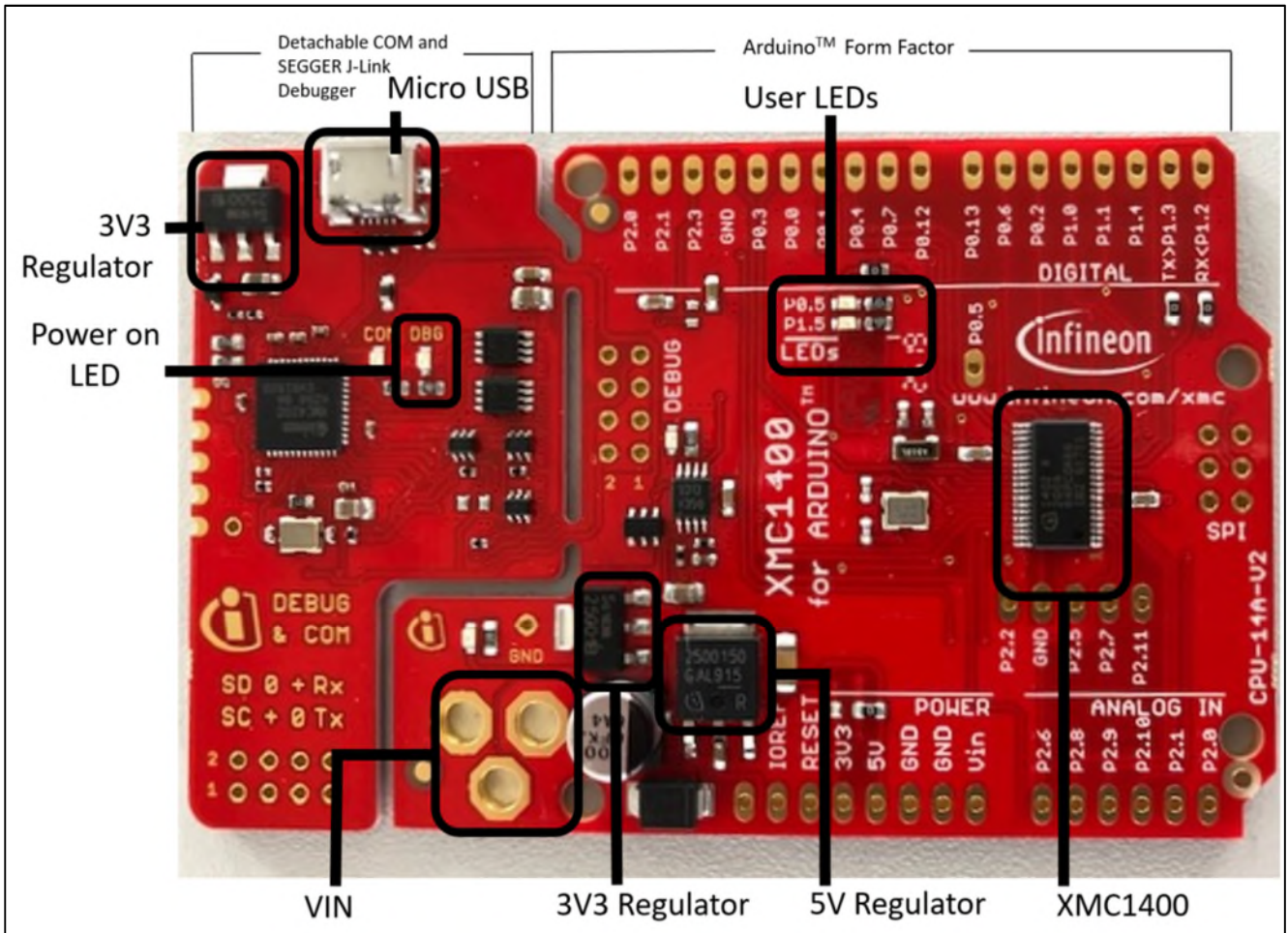

Figure 2 XMC1400 CPU Card for Arduino™

2.1 XMC1400 connector for ARDUINO™

2.1.1 Digital IO connector

XMC1400 CPU Card for Arduino™ have 10 pin connector mounting holes and 8 pin connector mounting holes at IOH and IOL respectively. Sixteen of those pins are digital input or output pins. The pinouts are listed in Table 1 and Table 2.

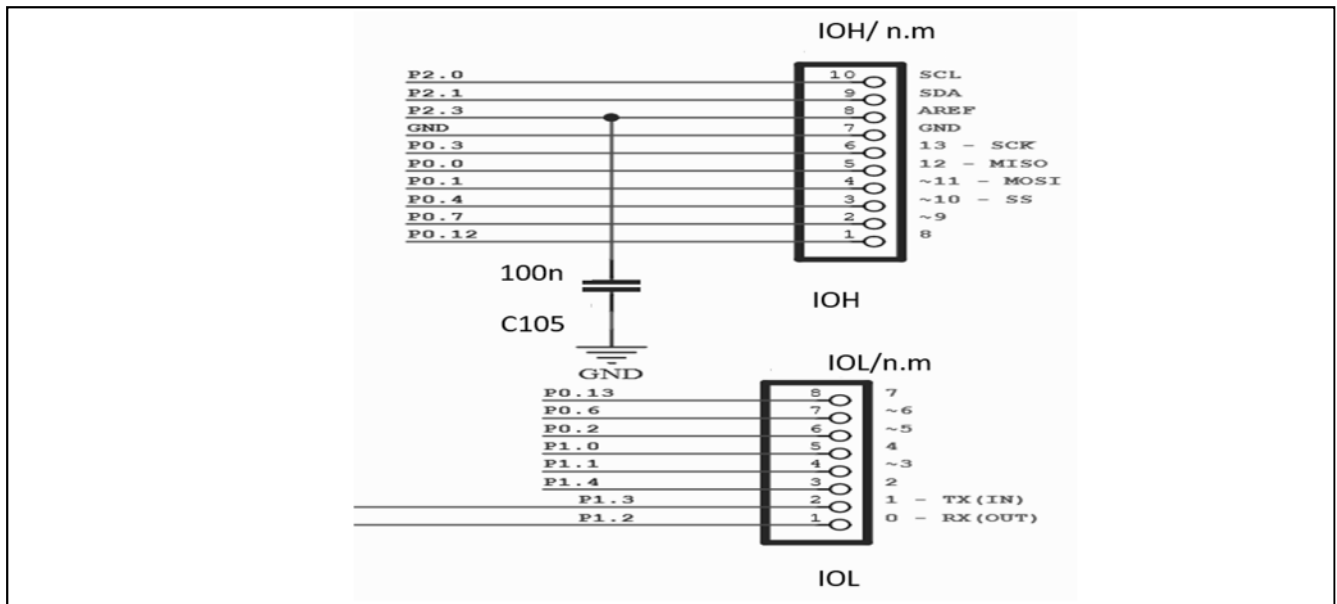

Figure 3 Digital IO connectors IOH, IOL

Table 1 Digital IO of connector IOH

Pin No.	Arduino™ Signal Name	XMC1400 Signal Name	Description
10	SCL	P2.0	I ² C Clock
9	SDA	P2.1	I ² C Data / Address
8	AREF	P2.3	Analog reference voltage
7	GND	GND	Ground
6	13 - SCK	P0.3	SPI-SCK / LED output
5	12 - MISO	P0.0	SPI-MISO
4	~11 - MOSI	P0.1	SPI-MOSI / PWM output
3	~10 - SS	P0.4	SPI-SS / PWM output
2	~9 -	P0.7	PWM output
1	8	P0.12	GPIO

Table 2 Digital IO of connector IOL

Pin No.	Arduino™ Signal Name	XMC1400 Signal Name	Description
8	7	P0.13	GPIO
7	~6	P0.6	PWM output
6	~5	P0.2	PWM output
5	4	P1.1	GPIO
4	~3	P0.0	External interrupt / PWM output
3	2	P1.4	External interrupt
2	1 - TX(IN)	P1.3	Device received UART signal
1	0 - RX(OUT)	P1.2	Device transmit UART signal

2.1.2 Analog input

XMC1400 CPU Card for Arduino™ has six analog inputs at connector AD.

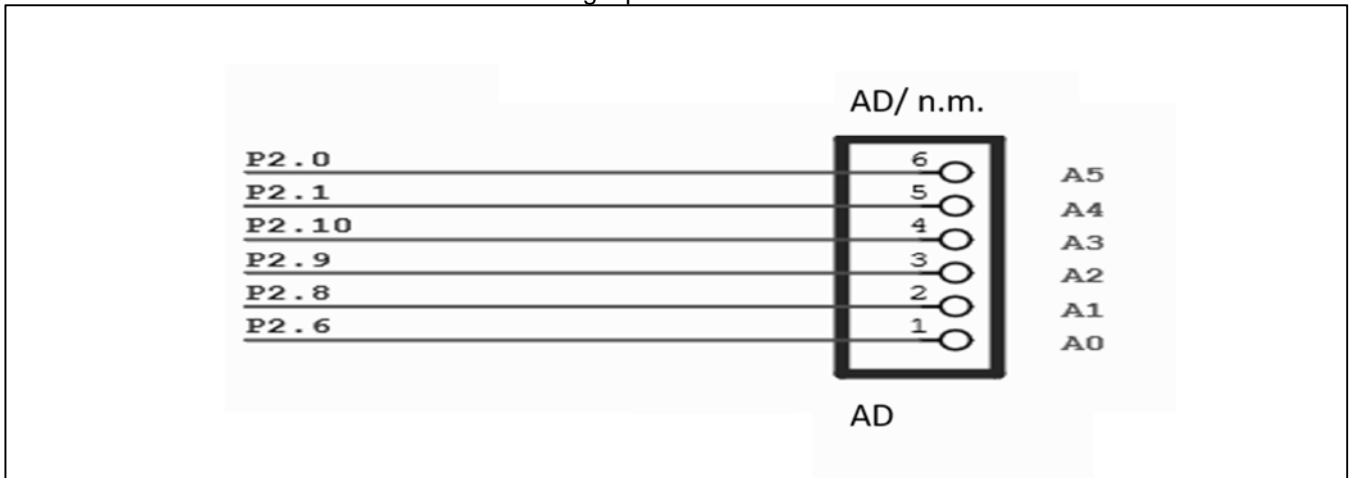

Figure 4 Analog input AD connector

Table 3 Pinout of the AD connector

Pin No.	Arduino™ Signal Name	XMC1400 Signal Name	Description
1	A0	P2.6	ADC Input
2	A1	P2.8	ADC Input
3	A2	P2.9	ADC Input
4	A3	P2.10	ADC Input
5	A4	P2.1	ADC Input
6	A5	P2.0	ADC Input

2.1.3 Power connector, POWER

XMC1400 CPU Card for Arduino™ can be powered from the micro USB connector or with an external power supply via the DC power jack. However, the DC power jack is not mounted.

The XMC1400 device can operate by power supply of 1.8V till 5.5Vdc. On this board, 5Vdc is used to power the XMC1400 device. However, if user wants to power the XMC1400 device with 3.3Vdc, then, please remove R102 and solder 0 ohm resistor R101.

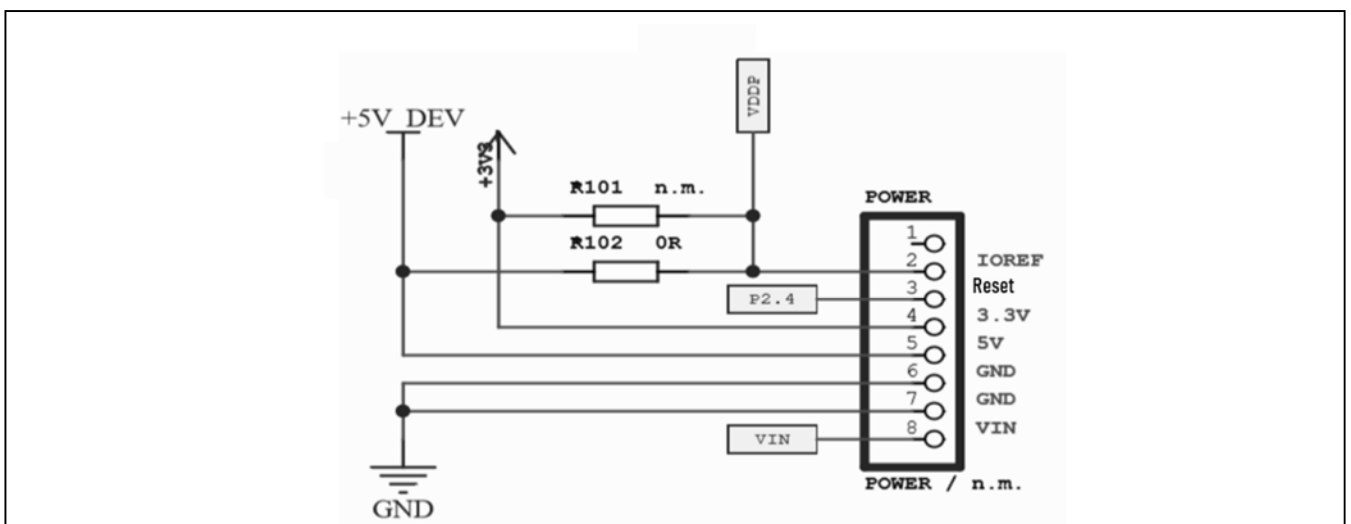

Figure 5 POWER connector

Table 4 Pinout of the POWER connector

Pin No.	Arduino™ Signal Name	XMC1400 Signal Name	Description
1	-	-	-
2	IOREF	VDDP	VDDP connect to 5V via R102
3	AREF	P2.4	ADC input to sense Analog reference voltage
4	3.3V	+3V3	3.3V is generated by a 3.3V regulator IC101 from +5V
5	5V	+5V	+5V is generated by the 5V regulator IC102 from VIN input. If VIN is not powered, +5V is supply by micro-USB connector.
6	GND	GND	Ground
7	GND	GND	Ground
8	VIN	VIN	DC jack (not mounted), 7-12V

2.1.4 ICSP (In-Circuit Serial Programming) Header

The SPI connector (not mounted) is used to program the XMC1100 microcontroller via the SPI interface.

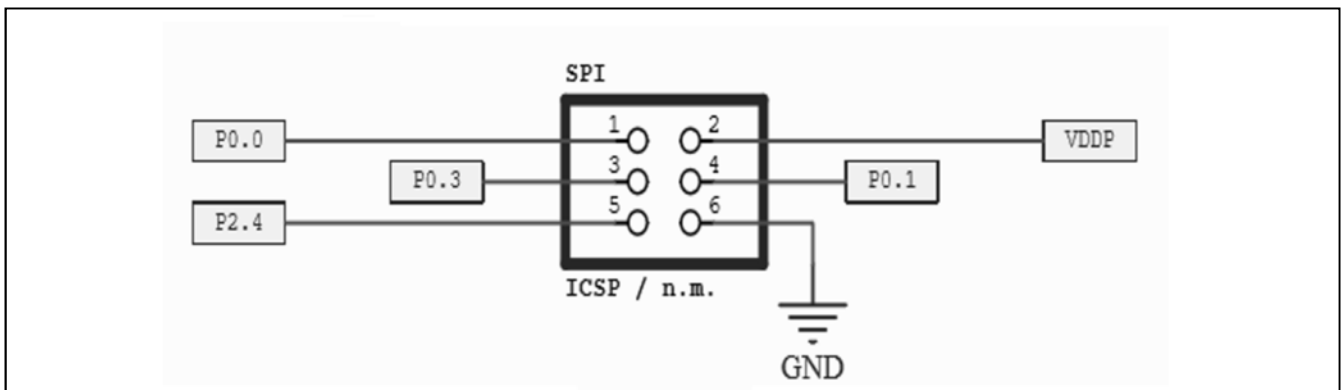

Figure 6 ICSP connector

Table 5 Signals of ICSP connector

Pin No.	Arduino™ Signal Name	XMC1400 Signal Name	Description
1	MISO	P0.0	Data transmit
2	+5V	VDDP	5Vdc
3	SCK	P0.3	Clock input
4	MOSI	P0.1	Data received
5	SS	P2.4	Chip select
6	GND	GND	ground

2.2 LEDs

Arduino™ pinout signal '13-SCK' is connected to yellow LED102 via a buffer. Furthermore, six surface mount LEDs are available for user signaling. Table 6 shows the LEDs driving signals.

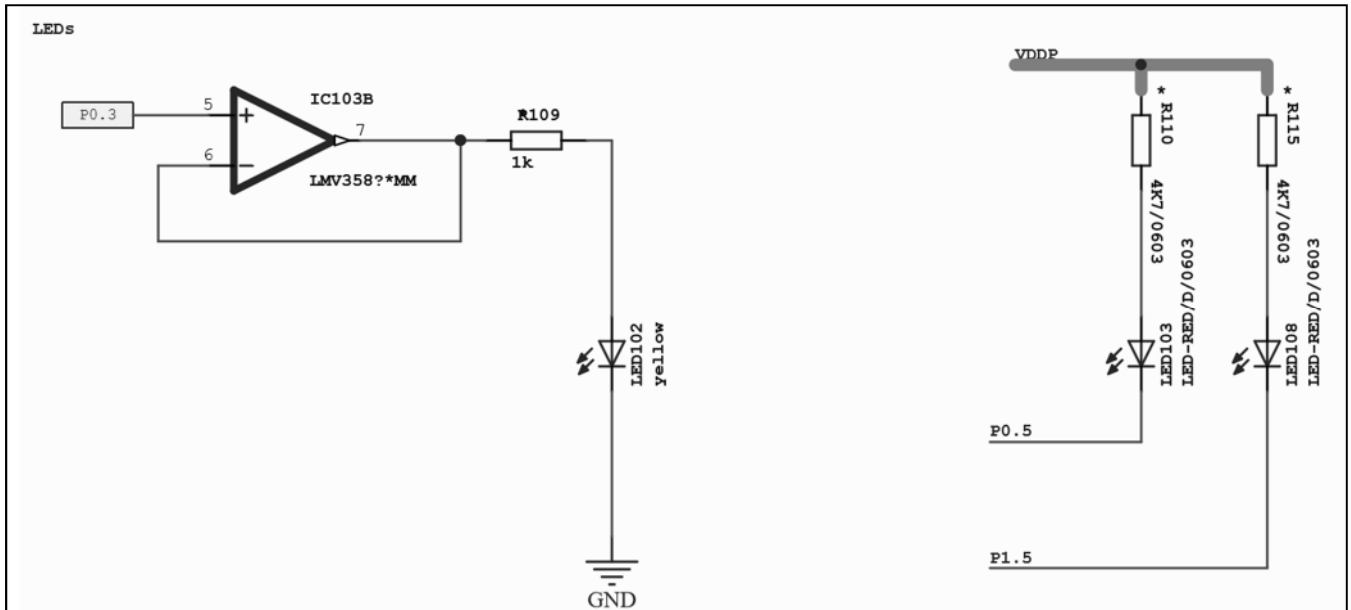

Figure 7 LEDs Circuit

Table 6 LEDs Signal Description

LED Designation	Signal Name	Description
LED102	P0.3	Output 'High' to on LED
LED103	P0.5	Output 'Low' to on LED
LED108	P1.5	Output 'Low' to on LED

2.3 Other connectors

XMC1400 microcontroller has more pins than is required Arduino™ board's pinouts, those extra pins are group into connector AD_AUX (not mount) and AUX (not mount).

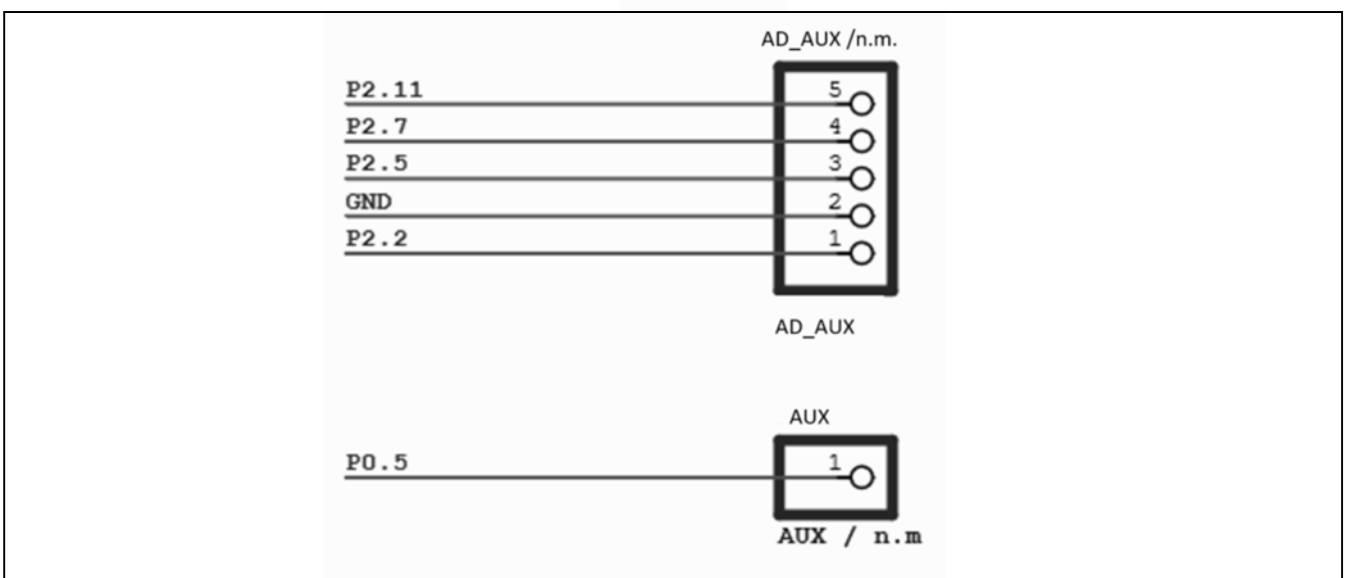

Figure 8 AD_AUX and AUX connector

Table 7 **Signals of connector AD_AUX**

Pin No.	Signal Name	Description
1	P2.2	ADC input
2	GND	ADC input
3	P2.5	ADC input
4	P2.7	ADC input
5	P2.11	ADC input

Table 8 **Signals of connector AUX**

Pin No.	Signal Name	Description
1	P0.5	GPIO

3 Production Data

3.1 Schematics

This chapter contains the schematics for the XMC1400 CPU Card for Arduino™:

- Figure 9: CPU, Pin Headers, LED, Power Supply
- Figure 10: On-board Debugger, Power

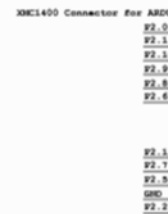
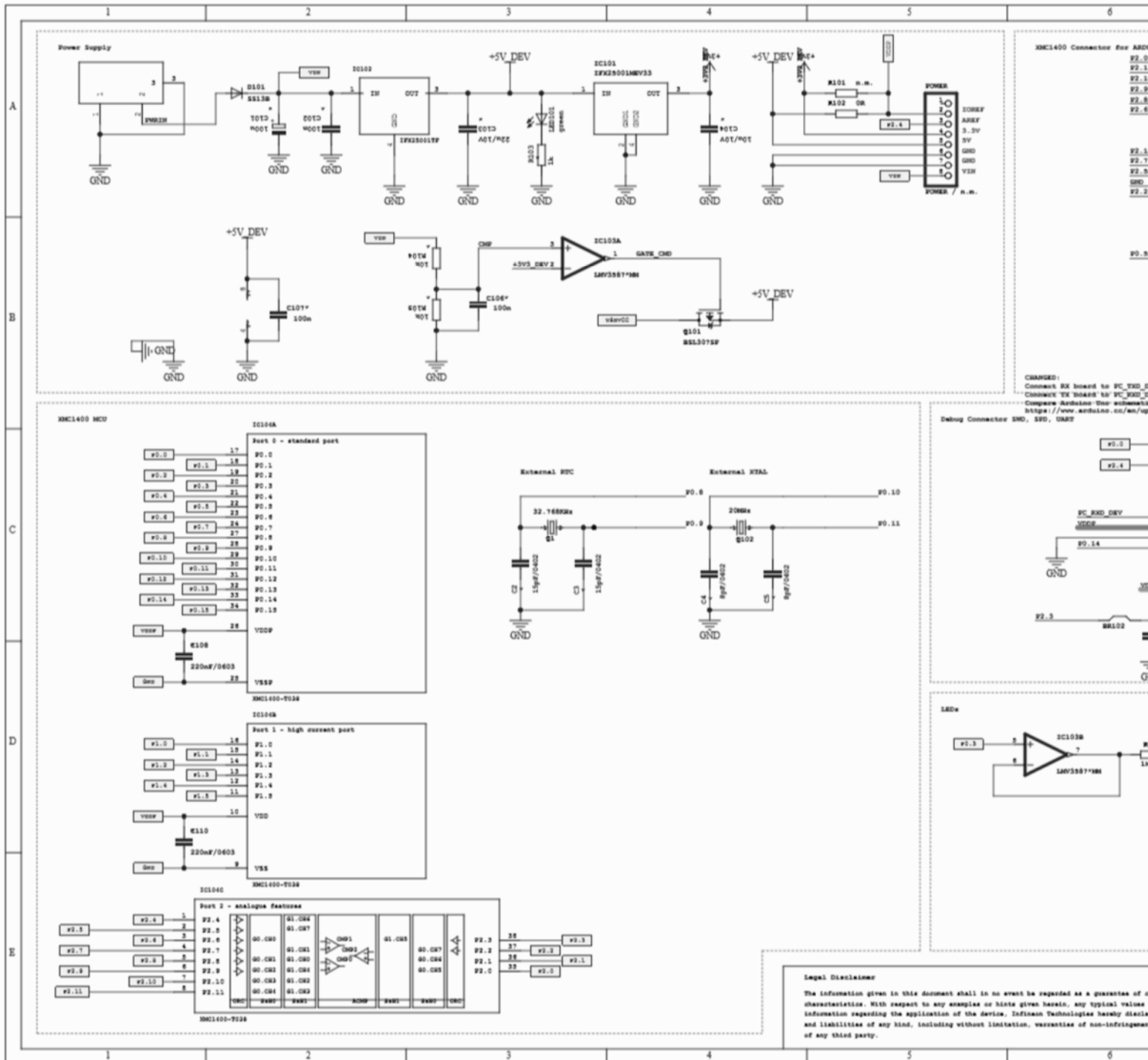

CHANGED:
 Connects BK board to PC_TXD_0
 Connects TX BOARD to PC_RXD_0
 Connects TX BOARD to PC_RXD_1
 Connects TX BOARD to PC_RXD_2
 Connects TX BOARD to PC_RXD_3
 Connects TX BOARD to PC_RXD_4
 Connects TX BOARD to PC_RXD_5
 Connects TX BOARD to PC_RXD_6
 Connects TX BOARD to PC_RXD_7
 Connects TX BOARD to PC_RXD_8
 Connects TX BOARD to PC_RXD_9
 Connects TX BOARD to PC_RXD_10
 Connects TX BOARD to PC_RXD_11
 Connects TX BOARD to PC_RXD_12
 Connects TX BOARD to PC_RXD_13
 Connects TX BOARD to PC_RXD_14
 Connects TX BOARD to PC_RXD_15
 Connects TX BOARD to PC_RXD_16
 Connects TX BOARD to PC_RXD_17
 Connects TX BOARD to PC_RXD_18
 Connects TX BOARD to PC_RXD_19
 Connects TX BOARD to PC_RXD_20
 Connects TX BOARD to PC_RXD_21
 Connects TX BOARD to PC_RXD_22
 Connects TX BOARD to PC_RXD_23
 Connects TX BOARD to PC_RXD_24
 Connects TX BOARD to PC_RXD_25
 Connects TX BOARD to PC_RXD_26
 Connects TX BOARD to PC_RXD_27
 Connects TX BOARD to PC_RXD_28
 Connects TX BOARD to PC_RXD_29
 Connects TX BOARD to PC_RXD_30
 Connects TX BOARD to PC_RXD_31
 Connects TX BOARD to PC_RXD_32
 Connects TX BOARD to PC_RXD_33
 Connects TX BOARD to PC_RXD_34
 Connects TX BOARD to PC_RXD_35
 Connects TX BOARD to PC_RXD_36
 Connects TX BOARD to PC_RXD_37
 Connects TX BOARD to PC_RXD_38
 Connects TX BOARD to PC_RXD_39
 Connects TX BOARD to PC_RXD_40
 Connects TX BOARD to PC_RXD_41
 Connects TX BOARD to PC_RXD_42
 Connects TX BOARD to PC_RXD_43
 Connects TX BOARD to PC_RXD_44
 Connects TX BOARD to PC_RXD_45
 Connects TX BOARD to PC_RXD_46
 Connects TX BOARD to PC_RXD_47
 Connects TX BOARD to PC_RXD_48
 Connects TX BOARD to PC_RXD_49
 Connects TX BOARD to PC_RXD_50
 Connects TX BOARD to PC_RXD_51
 Connects TX BOARD to PC_RXD_52
 Connects TX BOARD to PC_RXD_53
 Connects TX BOARD to PC_RXD_54
 Connects TX BOARD to PC_RXD_55
 Connects TX BOARD to PC_RXD_56
 Connects TX BOARD to PC_RXD_57
 Connects TX BOARD to PC_RXD_58
 Connects TX BOARD to PC_RXD_59
 Connects TX BOARD to PC_RXD_60
 Connects TX BOARD to PC_RXD_61
 Connects TX BOARD to PC_RXD_62
 Connects TX BOARD to PC_RXD_63
 Connects TX BOARD to PC_RXD_64
 Connects TX BOARD to PC_RXD_65
 Connects TX BOARD to PC_RXD_66
 Connects TX BOARD to PC_RXD_67
 Connects TX BOARD to PC_RXD_68
 Connects TX BOARD to PC_RXD_69
 Connects TX BOARD to PC_RXD_70
 Connects TX BOARD to PC_RXD_71
 Connects TX BOARD to PC_RXD_72
 Connects TX BOARD to PC_RXD_73
 Connects TX BOARD to PC_RXD_74
 Connects TX BOARD to PC_RXD_75
 Connects TX BOARD to PC_RXD_76
 Connects TX BOARD to PC_RXD_77
 Connects TX BOARD to PC_RXD_78
 Connects TX BOARD to PC_RXD_79
 Connects TX BOARD to PC_RXD_80
 Connects TX BOARD to PC_RXD_81
 Connects TX BOARD to PC_RXD_82
 Connects TX BOARD to PC_RXD_83
 Connects TX BOARD to PC_RXD_84
 Connects TX BOARD to PC_RXD_85
 Connects TX BOARD to PC_RXD_86
 Connects TX BOARD to PC_RXD_87
 Connects TX BOARD to PC_RXD_88
 Connects TX BOARD to PC_RXD_89
 Connects TX BOARD to PC_RXD_90
 Connects TX BOARD to PC_RXD_91
 Connects TX BOARD to PC_RXD_92
 Connects TX BOARD to PC_RXD_93
 Connects TX BOARD to PC_RXD_94
 Connects TX BOARD to PC_RXD_95
 Connects TX BOARD to PC_RXD_96
 Connects TX BOARD to PC_RXD_97
 Connects TX BOARD to PC_RXD_98
 Connects TX BOARD to PC_RXD_99

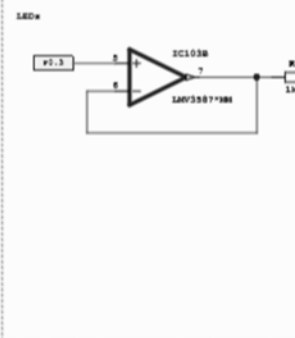
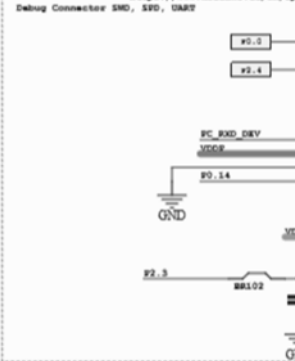

Legal Disclaimer
 The information given in this document shall in no event be regarded as a guarantee of performance or characterization. With respect to any examples or hints given herein, any typical values or information regarding the application of the device, Infineon Technologies hereby disclaims any and all liabilities, including without limitation, warranties of non-infringement of any third party.

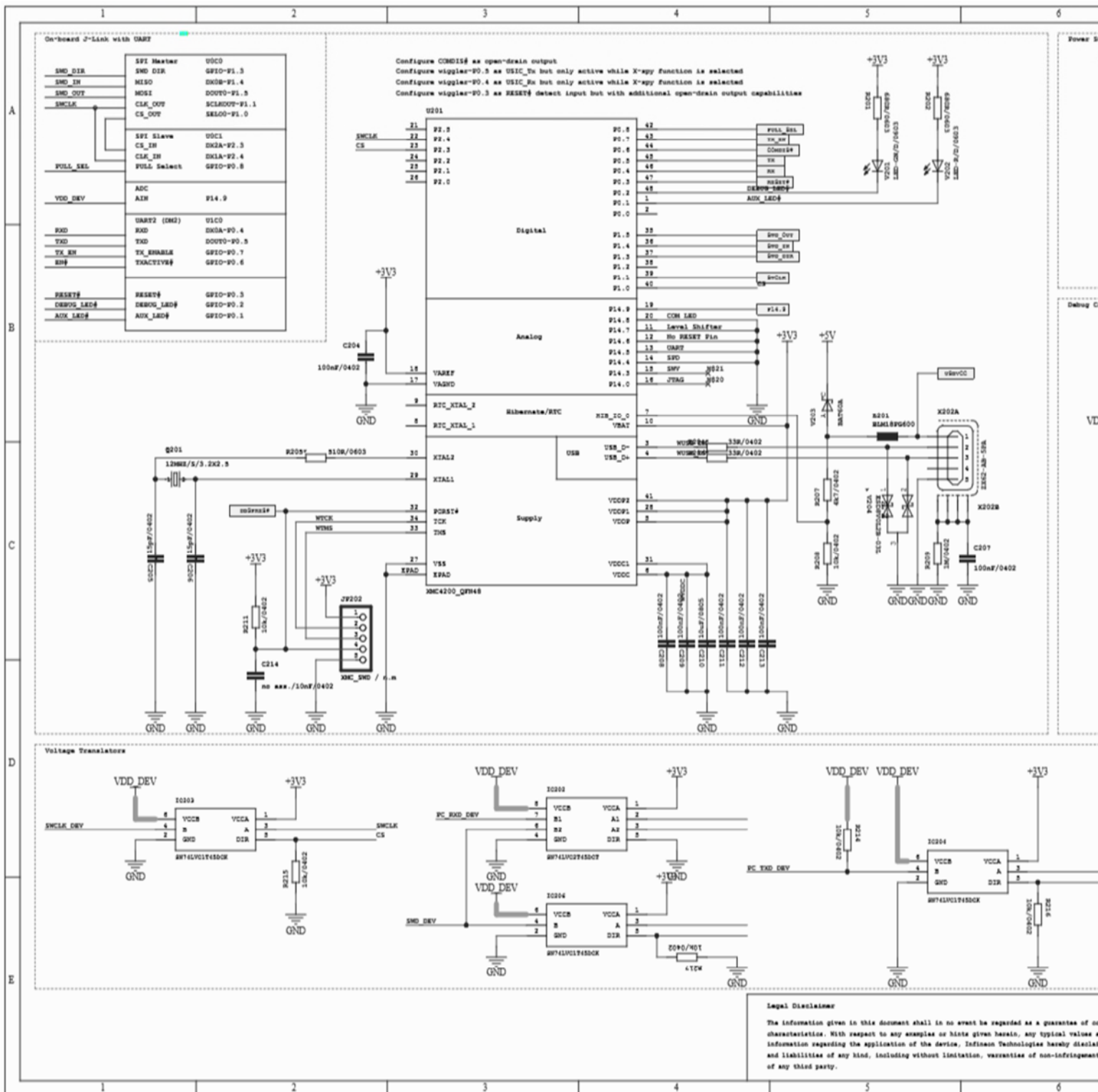

3.2 Layout and Geometry

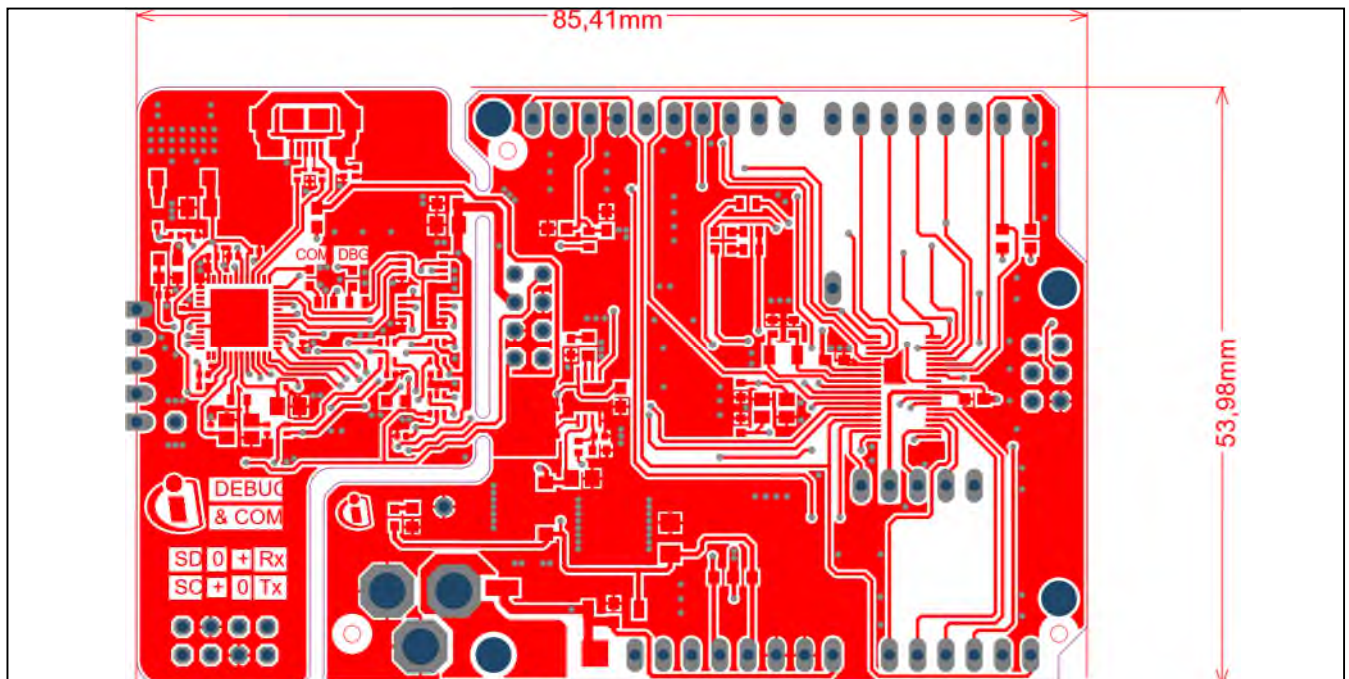

Figure 11 XMC1400 CPU Card for Arduino™ layout and geometry

3.3 Bill of Material

Table 9 XMC1400 CPU Card for Arduino™

No.	Qty	Value	Device	Reference Designator
1	1	AD / n.m.	PINHD-1X6	AD
2	3	FIDUCIAL	FIDUCIAL	ADJ_301, ADJ_302, ADJ_303
3	1	AD_AUX / n.m.	PINHD-1X5	AD_AUX
4	1	AUX / n.m	PINHD-1X1LONG	AUX
5	4	BRIDGE10X10	BRIDGE10X10	BR101, BR102, BR201, BR202
6	4	15pF/0402	RCL_C-EUC0402	C2, C3, C4, C5
7	1	100u	CPOL-EUD	C101
8	3	100n	C-EUC0603	C102, C105, C107
9	1	22u/10V	C-EUC1206	C103
10	1	10u/10V	C-EUC0805	C104
11	1	100n	C-EUC0402	C106
12	2	220nF/0603	RCL_C-EUC0603	C108, C110
13	1	100nF/0603	RCL_C-EUC0603	C109
14	1	22uF/10V/0805	C-EUC0805K	C201
15	1	10uF/10V/0805	C-EUC0805K	C202
16	1	100nF	CNP-0603	C203
17	8	100nF/0402	C-EUC0402	C204, C207, C208, C209, C211, C212, C213, C215
18	2	15pF/0402	C-EUC0402	C205, C206

No.	Qty	Value	Device	Reference Designator
19	1	10uF/0805	C-EUC0805K	C210
20	1	no ass./10nF/0402	C-EUC0402	C214
21	1	SS13B	DIODE-SMB	D101
22	2	IFX25001MEV33	IFX25001MEV33	IC101, IC201
23	1	IFX25001TFV50	IFX25001TFV50	IC102
24	1	LMV358MM	LMV358MM	IC103
25	1	XMC1400-T038	XMC1400-T038	IC104
26	2	SN74LVC2T45DCT	SN74LVC2T45DCT	IC202, IC205
27	3	SN74LVC1T45DCK	SN74LVC1T45DCK	IC203, IC204, IC206
28	1	IOH / n.m.	PINHD-1X10	IOH
29	1	IOL / n.m.	PINHD-1X8	IOL
30	1	XMC_SWD / n.m	PINHD-1X5	JP202
31	1	BLM18PG600	L_EU_L0603	L201
32	1	green	LEDCHIPLD_0603	LED101
33	1	yellow	LEDCHIPLD_0603	LED102
34	2	LED-RED/D/0603	LED_LEDCHIP-LED0603	LED103, LED108
35	1	INFINEONS5	INFINEONS5	LOGO301
36	1	GND-PAD	GND-PAD	P101
37	1	INFINEONI3	INFINEONI3	PAGE101
38	1	INFINEONI5	INFINEONI5	PAGE201
39	1	POWER / n.m.	PINHD-1X8	POWER
40	1	32.768KHz	MARS_FC135-32.768KHZ	Q1
41	1	BSL307SP	BSL307SP	Q101
42	1	CRYTAL_32X25_4PAD	CRYTAL_32X25_4PAD	Q102
43	1	CRYTAL_32X25_4PAD	CRYTAL_32X25_4PAD	Q201
44	1	n.m.	R-EU_R0603	R101
45	3	OR	R-EU_R0603	R102, R106, R107
46	2	1k	R-EU_R0603	R103, R109
47	2	10k	R-EU_R0402	R104, R105
48	1	OR/0603/NA	DSR_R-EU_R0603	R108
49	2	4K7/0603	DSR_R-EU_R0603	R110, R115
50	1	OR/0603	DSR_R-EU_R0603	R116
51	2	680R/0603	R-EU_R0603	R201, R202
52	2	33R/0402	R-EU_R0402	R204, R206
53	1	510R/0603	R-EU_R0603	R205
54	1	4k7/0402	R-EU_R0402	R207
55	6	10k/0402	R-EU_R0402	R208, R211, R214, R215, R216, R217
56	1	1M/0402	R-EU_R06030402	R209
57	2	5K10 / 1%	R-EU_R0603	R210, R212
58	1	n.m./0603	R-EU_R0603	R213
59	1	SEGGER.L_STOP	SEGGER.L_STOP	SEGGER201
60	1	ICSP / n.m.	PINHD-2X3	SPI
61	1	XMC4200_QFN48	XMC4200_QFN48	U201
62	1	LED-GN/D/0603	LEDCHIPLD_0603	V201

No.	Qty	Value	Device	Reference Designator
62	1	LED-R/D/0603	LEDCHIPLD_0603	V202
63	1	BAT60A	BAT60	V203
64	1	ESD_2CH_TSFP-3-1	ESD_2CH_TSFP-3-1	V204
65	1	DC21MMX / n.m.	DC21MMX	X101
66	1	Debug / m.n.	MA04-2	X102
67	1	DEBUG / n.m.	MA04-2	X201
68	1	ZX62-AB-5PA	ZX62-AB-5PA_MICRO-	X202
69	1	RESET / n.m.	PINH-1X1	X203

www.infineon.com

Published by Infineon Technologies AG

X-ON Electronics

Largest Supplier of Electrical and Electronic Components

Click to view similar products for [Development Boards & Kits - ARM category](#):

Click to view products by [Infineon manufacturer](#):

Other Similar products are found below :

[SAFETI-HSK-RM48](#) [PICOHOBBITFL](#) [CC-ACC-MMK-2443](#) [EVALSPEAR320CPU](#) [TMDX570LS04HDK](#) [TXSD-SV70](#) [TXSD-SV71](#)
[YGRPEACHNORMAL](#) [PICODWARFFL](#) [YR8A77450HA02BG](#) [3580](#) [32F3348DISCOVERY](#) [ATTINY1607](#) [CURIOSITY NANO](#)
[PIC16F15376](#) [CURIOSITY NANO BOARD](#) [PIC18F47Q10](#) [CURIOSITY NANO](#) [VISIONSTK-6ULL V.2.0](#) [80-001428](#) [DEV-17717](#)
[EAK00360](#) [YR0K77210B000BE](#) [RTK7EKA2L1S00001BE](#) [SLN-VIZN-IOT](#) [LV18F V6 DEVELOPMENT SYSTEM](#) [READY FOR AVR](#)
[BOARD](#) [READY FOR PIC BOARD](#) [READY FOR PIC \(DIP28\)](#) [AVRPLC16 V6 PLC SYSTEM](#) [MIKROLAB FOR AVR XL](#) [MIKROLAB](#)
[FOR PIC L](#) [MINI-AT BOARD - 5V](#) [MINI-M4 FOR STELLARIS](#) [MOD-09.Z](#) [BUGGY + CLICKER 2 FOR PIC32MX + BLUETOOT](#) [1410](#)
[LETS MAKE PROJECT PROGRAM. RELAY PIC](#) [LETS MAKE - VOICE CONTROLLED LIGHTS](#) [LPC-H2294](#) [DSPIC-READY2 BOARD](#)
[DSPIC-READY3 BOARD](#) [MIKROBOARD FOR ARM 64-PIN](#) [MIKROLAB FOR AVR](#) [MIKROLAB FOR AVR L](#) [MIKROLAB FOR](#)
[DSPIC](#) [MIKROLAB FOR DSPIC XL](#) [MIKROLAB FOR PIC32](#) [MIKROLAB FOR TIVA](#) [EASYAVR V7](#) [EASYMX PRO FOR TIVA C](#)
[SERIES](#) [EASYMX PRO V7 FOR STM32](#) [EASYPIC FUSION V7](#)