

Colour LED Card

For XMC1000 Family

inLight_RGB_V3

Colour LED Card

Board User's Manual

Revision 1.0, 2013-03-08

Microcontroller

Edition 2013-03-08

**Published by
Infineon Technologies AG
81726 Munich, Germany**

**© 2013 Infineon Technologies AG
All Rights Reserved.**

Legal Disclaimer

The information given in this document shall in no event be regarded as a guarantee of conditions or characteristics. With respect to any examples or hints given herein, any typical values stated herein and/or any information regarding the application of the device, Infineon Technologies hereby disclaims any and all warranties and liabilities of any kind, including without limitation, warranties of non-infringement of intellectual property rights of any third party.

Information

For further information on technology, delivery terms and conditions and prices, please contact the nearest Infineon Technologies Office (www.infineon.com).

Warnings

Due to technical requirements, components may contain dangerous substances. For information on the types in question, please contact the nearest Infineon Technologies Office.

Infineon Technologies components may be used in life-support devices or systems only with the express written approval of Infineon Technologies, if a failure of such components can reasonably be expected to cause the failure of that life-support device or system or to affect the safety or effectiveness of that device or system. Life support devices or systems are intended to be implanted in the human body or to support and/or maintain and sustain and/or protect human life. If they fail, it is reasonable to assume that the health of the user or other persons may be endangered.

Revision History

Page or Item	Subjects (major changes since previous revision)
Revision 1.0, 2013-03-08	

Trademarks of Infineon Technologies AG

AURIX™, C166™, CanPAK™, CIPOS™, CIPURSE™, EconoPACK™, CoolMOS™, CoolSET™, CORECONTROL™, CROSSAVE™, DAVE™, DI-POL™, EasyPIM™, EconoBRIDGE™, EconoDUAL™, EconoPIM™, EconoPACK™, EiceDRIVER™, eupec™, FCOS™, HITFET™, HybridPACK™, I²RF™, ISOFACE™, IsoPACK™, MIPAQ™, ModSTACK™, my-d™, NovalithIC™, OptiMOS™, ORIGA™, POWERCODE™, PRIMARION™, PrimePACK™, PrimeSTACK™, PRO-SIL™, PROFET™, RASIC™, ReverSave™, SatRIC™, SIEGET™, SINDRION™, SIPMOS™, SmartLEWIS™, SOLID FLASH™, TEMPFET™, thinQ!™, TRENCHSTOP™, TriCore™.

Other Trademarks

Advance Design System™ (ADS) of Agilent Technologies, AMBA™, ARM™, MULTI-ICE™, KEIL™, PRIMECELL™, REALVIEW™, THUMB™, µVision™ of ARM Limited, UK. AUTOSAR™ is licensed by AUTOSAR development partnership. Bluetooth™ of Bluetooth SIG Inc. CAT-iq™ of DECT Forum. COLOSSUS™, FirstGPS™ of Trimble Navigation Ltd. EMV™ of EMVCo, LLC (Visa Holdings Inc.). EPCOS™ of Epcos AG. FLEXGO™ of Microsoft Corporation. FlexRay™ is licensed by FlexRay Consortium. HYPERTERMINAL™ of Hilgraeve Incorporated. IEC™ of Commission Electrotechnique Internationale. IrDA™ of Infrared Data Association Corporation. ISO™ of INTERNATIONAL ORGANIZATION FOR STANDARDIZATION. MATLAB™ of MathWorks, Inc. MAXIM™ of Maxim Integrated Products, Inc. MICROTEC™, NUCLEUS™ of Mentor Graphics Corporation. MIPI™ of MIPI Alliance, Inc. MIPS™ of MIPS Technologies, Inc., USA. muRata™ of MURATA MANUFACTURING CO., MICROWAVE OFFICE™ (MWO) of Applied Wave Research Inc., OmniVision™ of OmniVision Technologies, Inc. Openwave™ Openwave Systems Inc. RED HAT™ Red Hat, Inc. RFMD™ RF Micro Devices, Inc. SIRIUS™ of Sirius Satellite Radio Inc. SOLARIS™ of Sun Microsystems, Inc. SPANSION™ of Spansion LLC Ltd. Symbian™ of Symbian Software Limited. TAIYO YUDEN™ of Taiyo Yuden Co. TEAKLITE™ of CEVA, Inc. TEKTRONIX™ of Tektronix Inc. TOKO™ of TOKO KABUSHIKI KAISHA TA. UNIX™ of X/Open Company Limited. VERILOG™, PALLADIUM™ of Cadence Design Systems, Inc. VLYNQ™ of Texas Instruments Incorporated. VXWORKS™, WIND RIVER™ of WIND RIVER SYSTEMS, INC. ZETEX™ of Diodes Zetex Limited.

Last Trademarks Update 2011-11-11

Table of Contents

1	Overview	7
1.1	Key Features	7
1.2	Block Diagram	7
2	Hardware Description	8
2.1	RGB LEDs	8
2.2	Digital Addressable Lighting Interface (DALI)	9
2.3	DMX512/ Remote Device Management (RDM)	10
2.4	433MHz RF Receiver	11
2.5	Light Sensor	11
2.6	Power	12
2.7	2x30pins SAMTEC connector	12
3	Production Data.....	14
3.1	Schematics	14
3.2	Layout and Geometry	16
3.3	Bill of Materials	16

List of Figures

Figure 1	Block Diagram of Colour LED Card in connection with XMC1200 CPU Card	7
Figure 2	Colour LED Card	8
Figure 3	9 channels from BCCU module to control the three RGB LED modules	9
Figure 4	DALI PHY circuit	10
Figure 5	DMX512/RDM Circuit	10
Figure 6	433MHz RF receiver circuit	11
Figure 7	Ambient Light Sensing Circuit	12
Figure 8	VIN External Power Supply	12
Figure 9	SAMTEC 2x30pins SAMTEC connector	13
Figure 10	Schematic of Colour LED Card	15
Figure 11	Colour LED Card layout and geometry	16

List of Tables

Table 1	BCCU signal connection to the SAMTEC 2x30pins Connector.....	9
Table 2	DALI signal connection to the SAMTEC 2x30pins connector.....	10
Table 3	DMX512 signals connection to the SAMTEC 2x30pins connector.....	11
Table 4	433MHz RF receiver signal connection to the SAMTEC 2x30pins connector.....	11
Table 5	Light sensing signals connection to the SAMTEC 2x30pins connector.....	12
Table 6	Power and ground signals connection to the SAMTEC 2x30pins connector.....	12
Table 7	Colour LED Card BOM.....	16

Introduction

This document describes the features and hardware details of the Colour LED Card (inLight_RGB_v3) designed to work with Infineon's XMC1200 CPU Card. This board is part of Infineon's XMC1000's LED Lighting Application Kit.

1 Overview

The Colour LED Card is an application expansion card of XMC1000 LED Lighting Application Kit. This application card along with a XMC1200 CPU Card demonstrates the LED lighting capabilities of XMC1200/XMC1300. The main use case for this application card is to demonstrate the smooth colour control of XMC1200/XMC1300 device including the toolchain. The focus is safe operation under evaluation conditions. The board is not cost optimized and cannot be seen as reference design.

1.1 Key Features

The Colour LED Card is equipped with the following features

- Connection to XMC1200/XMC1300 CPU Cards via 2x30 pins (0.8mm pitch) SAMTEC HSEC8 connector
- RGB control of three independent LEDs (OSRAM LRTB-G6SF)
- DALI interface with isolation
- DMX512 interface without isolation
- Ambient light sensing
- 433MHz RF receiver
- +5V Power supply via SAMTEC 2x30pins connector
- +12V external connection to supply power to the 3 LEDs

1.2 Block Diagram

Figure 1 shows the block diagram of the Colour LED Card in connection with XMC1200 CPU Card. There are following blocks:

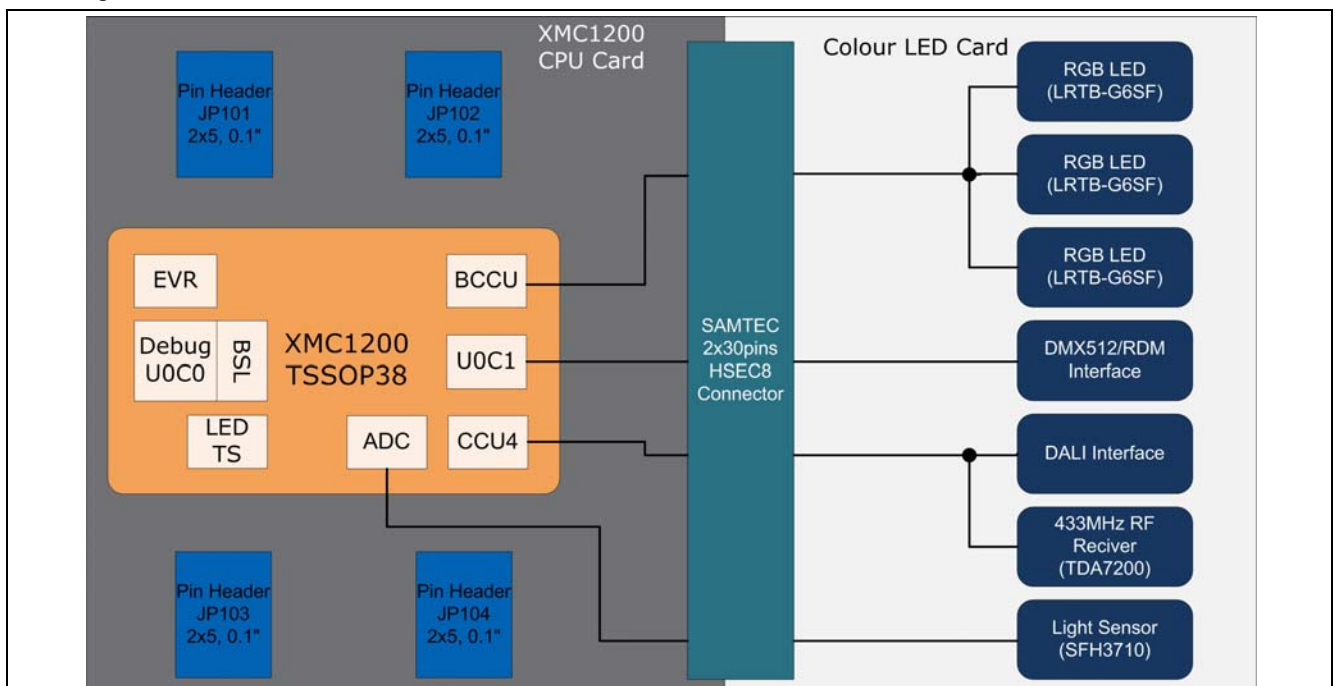

Figure 1 Block Diagram of Colour LED Card in connection with XMC1200 CPU Card

2 Hardware Description

The following sections give a detailed description of the hardware and how it can be used.

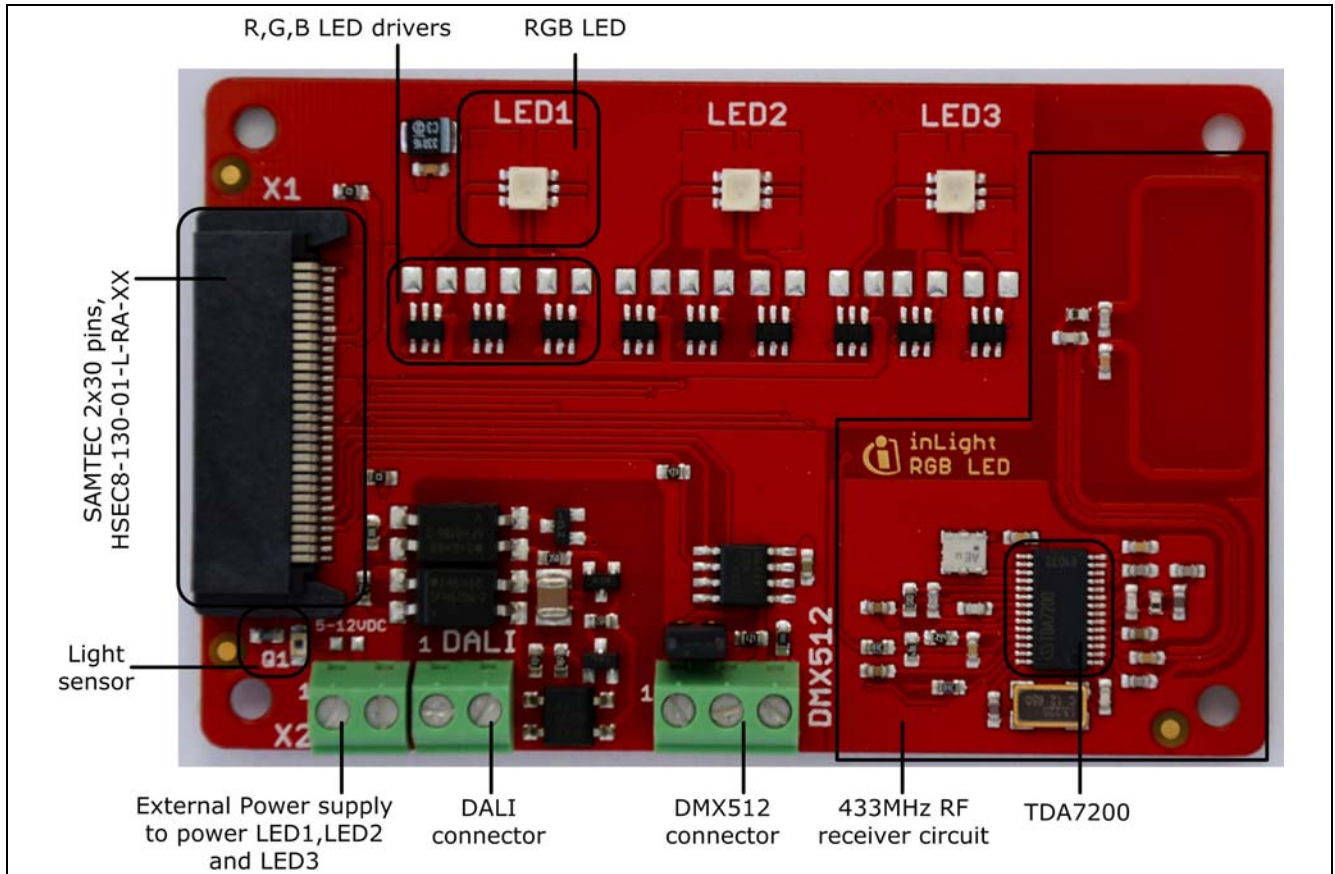

Figure 2 Colour LED Card

2.1 RGB LEDs

The Colour LED Card supports individual control of three OSRAM RGB LEDs (LRTB-G6SF), namely LED1, LED2, LED3, on board. The forward voltage V_F is $2 \sim 3.2 \text{ V} @ I_F=20\text{mA}$.

The card implements brightness and color control through BCCU module of XMC1200. The BCCU module has 9 channels to drive 9 LED drivers (BCR421) which control the current flow through the Red, Green and Blue LEDs of the three OSRAM LED module.

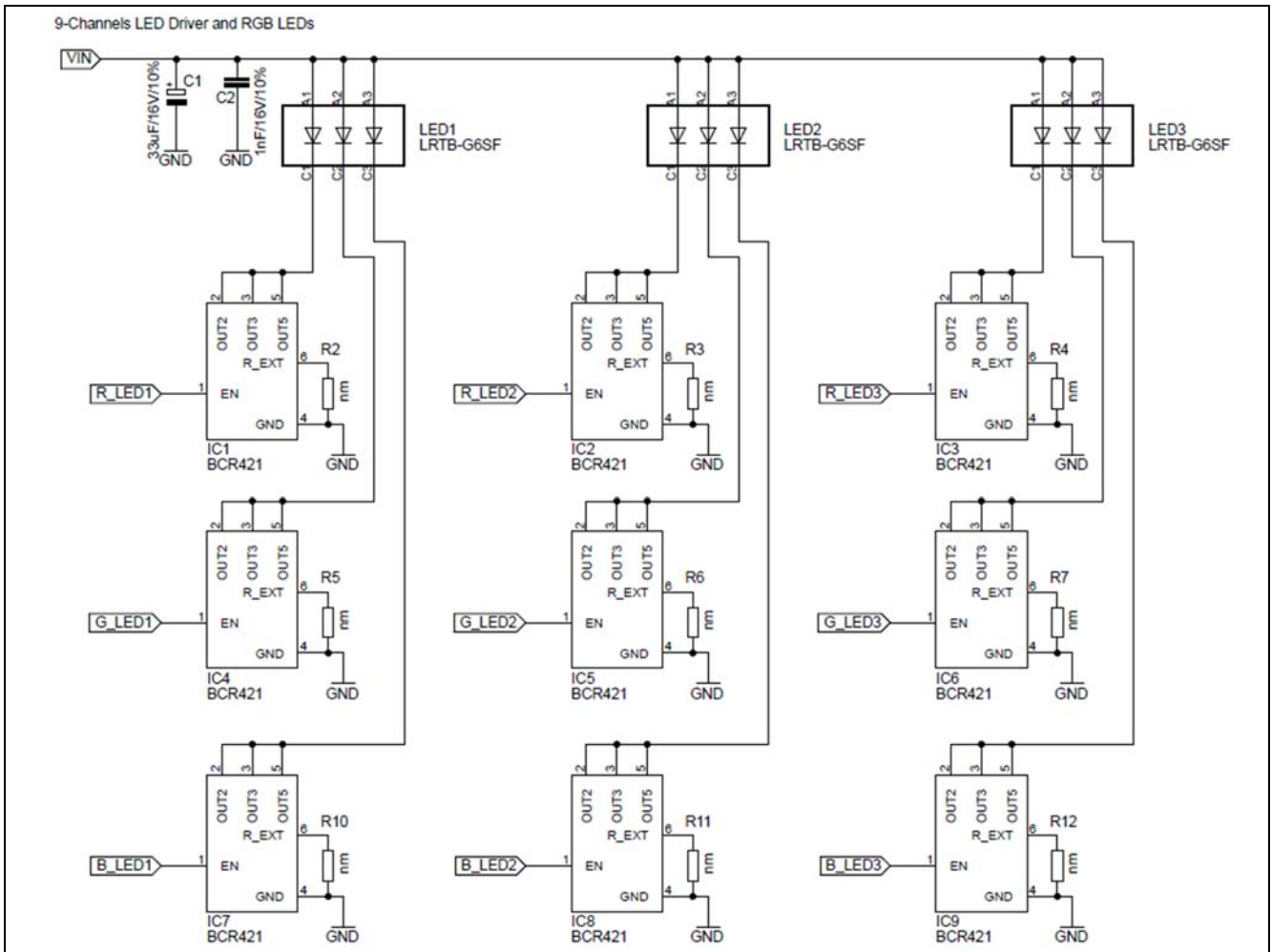

Figure 3 9 channels from BCCU module to control the three RGB LED modules

Table 1 shows the connection of the BCCU signals to the SAMTEC 2x30pins connector.

Table 1 BCCU signal connection to the SAMTEC 2x30pins Connector

Pin No.	Signal Name	Description
19	B_LED1	Blue channel of LED1
25	R_LED1	Red channel of LED1
27	R_LED2	Red channel of LED2
29	G_LED2	Green channel of LED2
31	B_LED2	Blue channel of LED2
33	R_LED3	Red channel of LED3
35	G_LED3	Green channel of LED3
37	B_LED3	Blue channel of LED3
39	G_LED1	Green channel of LED1

2.2 Digital Addressable Lighting Interface (DALI)

The Colour LED Card supports DALI interface on board with two optocoupler (SFH6186-2) which provide level shifting and voltage isolation between the DALI network and the microcontroller's power supply. The DALI connector X3 consists of a DATA+ and DATA- signal pair.

Note: Please remove R105 of XMC1200 CPU Card when using DALI for receiving data.

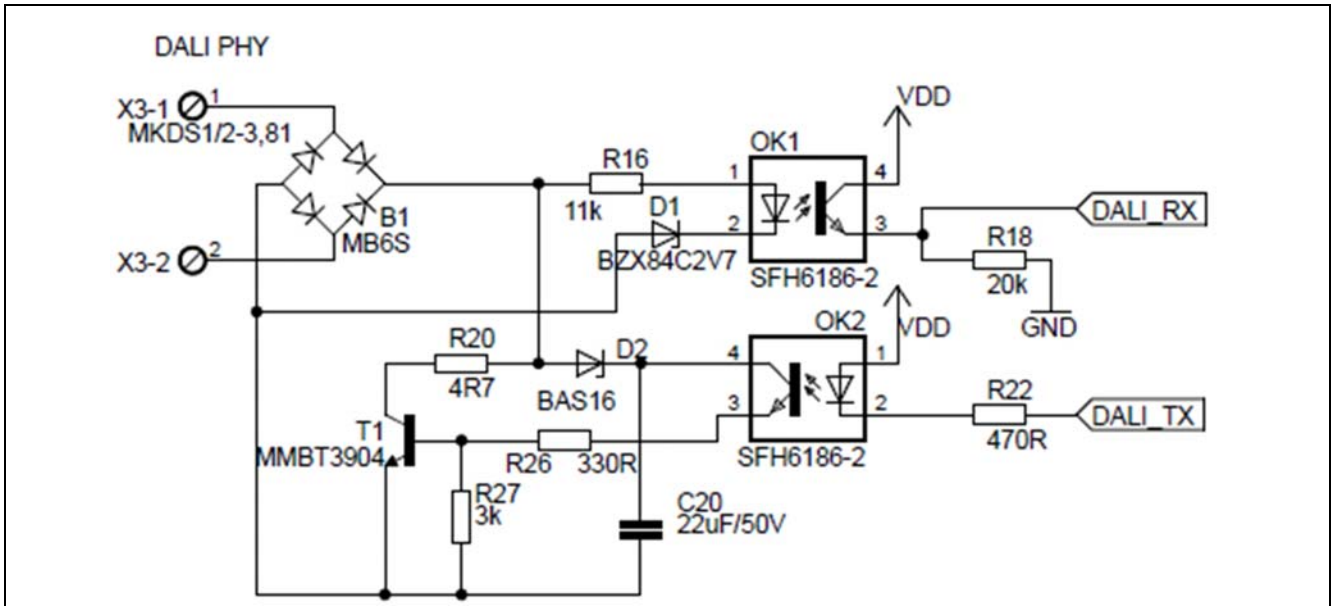

Figure 4 DALI PHY circuit

Table 2 DALI signal connection to the SAMTEC 2x30pins connector

Pin No.	Signal Name	Description
21	DALI_RX	DALI data received
23	DALI_TX	DALI data transmit

2.3 DMX512/ Remote Device Management (RDM)

The Colour LED Card supports DMX512 interface on board with RS-485 transceiver (MAX481CSA). The DMX512 connector X4 consists of a 120 ohms termination resistor between DATA+ and DATA- and a Ground pin.

Note: There is NO isolation between external DMX512 signals and the XMC1200's DMX512 interface signals.

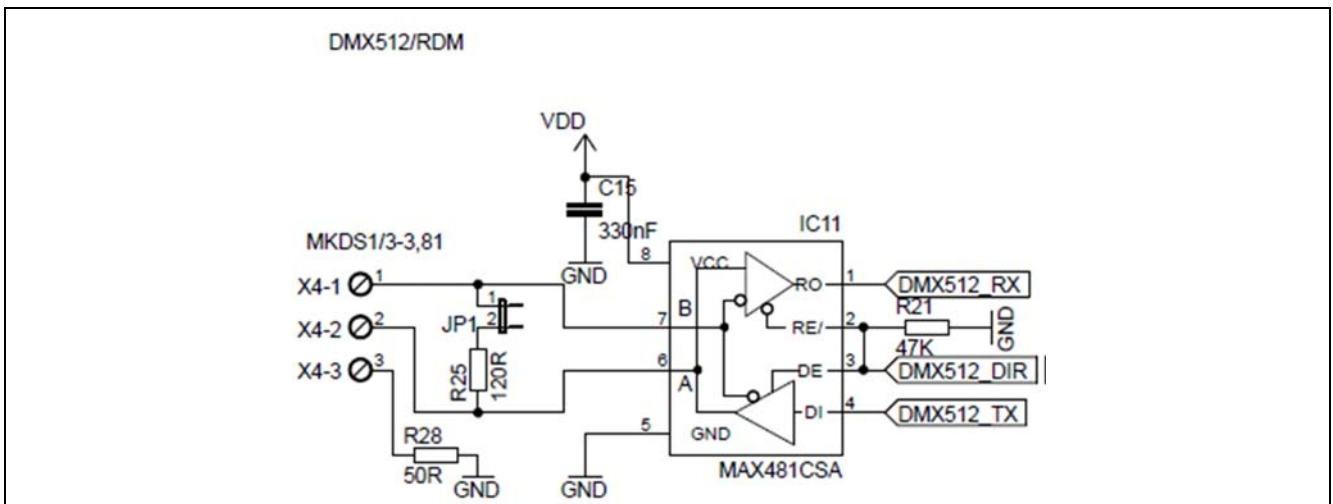

Figure 5 DMX512/RDM Circuit

Table 3 shows the connection of the DMX512 signals to the SAMTEC 2X30pins connector.

Table 3 DMX512 signals connection to the SAMTEC 2x30pins connector

Pin No.	Signal Name	Description
50	DMX512_TX	DMX512 data transmit out
52	DMX512_RX	DMX512 data receive in
54	DMX512_DIR	Transceiver direction control

2.4 433MHz RF Receiver

The Colour LED Card supports 433MHz remote control system via a 433MHz RF Receiver (TDA7200) that is connected to the CPU Card via the SAMTEC 2X30pins connector.

Note: Please remove R104 of XMC1200/XMC1300 CPU Card when using the 433MHz RF receiver.

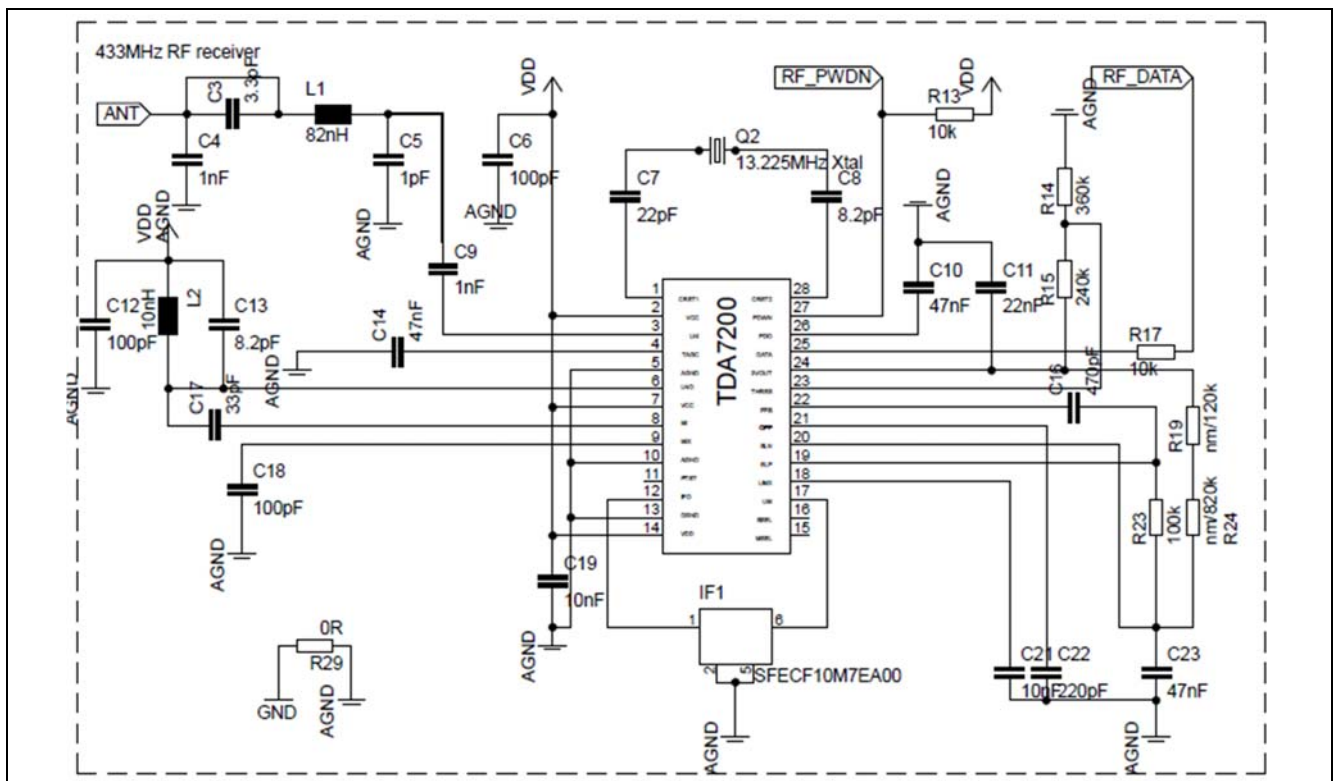

Figure 6 433MHz RF receiver circuit

Table 4 433MHz RF receiver signal connection to the SAMTEC 2x30pins connector

Pin No.	Signal Name	Description
17	RF_DATA	RF Data In
43	RF_PWDN	Tied to 'High' to enable receiver

2.5 Light Sensor

The Colour LED Card supports ambient light sensing on board with NPN Phototransistor (SFH3710). The voltage output AMB_LT will be measured by the ADC module.

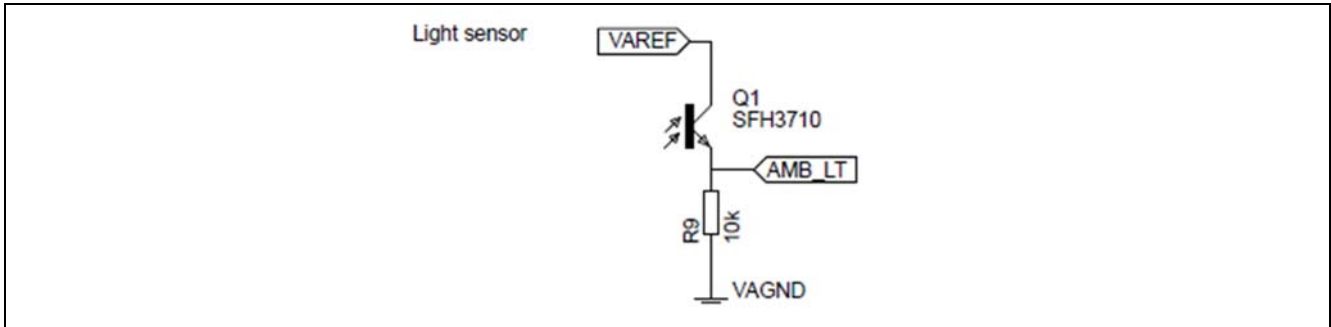

Figure 7 Ambient Light Sensing Circuit

Table 5 shows the connection of the DMX512 signals to the SAMTEC 2X30pins connector.

Table 5 Light sensing signals connection to the SAMTEC 2x30pins connector

Pin No.	Signal Name	Description
2	AMB_LT	Light sensing output

2.6 Power

Power input (5V) to the Application card is supported through the SAMTEC 2x30pins connector. VAREF and VAGND supply power to 433MHz RF Receiver and Light sensing transistor. VDD and GND provide power to the DALI and DMX512 circuitry.

VIN supply power to the three RGB LEDs and is shorted to VDD via a zero ohm resistor R1. However, user could also connect VIN to external power supply by removed R1, soldered zero ohm resistor R8 and connected external power supply to connector X2.

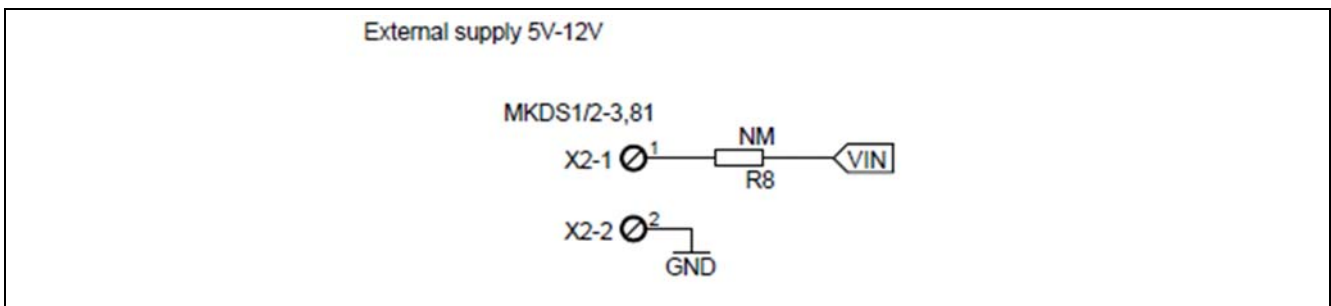

Figure 8 VIN External Power Supply

Table 6 Power and ground signals connection to the SAMTEC 2x30pins connector

Pin No.	Signal Name	Description
13	VAGND	Analog ground
14	GND	Digital ground
15	VAREF	Analog VDD +5V
16	VDD	Digital VDDP +5V

2.7 2x30pins SAMTEC connector

The SAMTEC connector of the Colour LED Card interfaces its signals to XMC1200 CPU Card.

XMC1200_TSSOP38 Board>>		P2.11																																					
XMC1200_TSSOP38 Board>>																																							

Figure 9 SAMTEC 2x30pins SAMTEC connector

3 Production Data

3.1 Schematics

This chapter contains the schematics for the Colour LED Card:

- SAMTEC Connector, Power, 9 channels LED driver, DALI interface, DMX512/RDM interface, 433MHz RF Receiver.

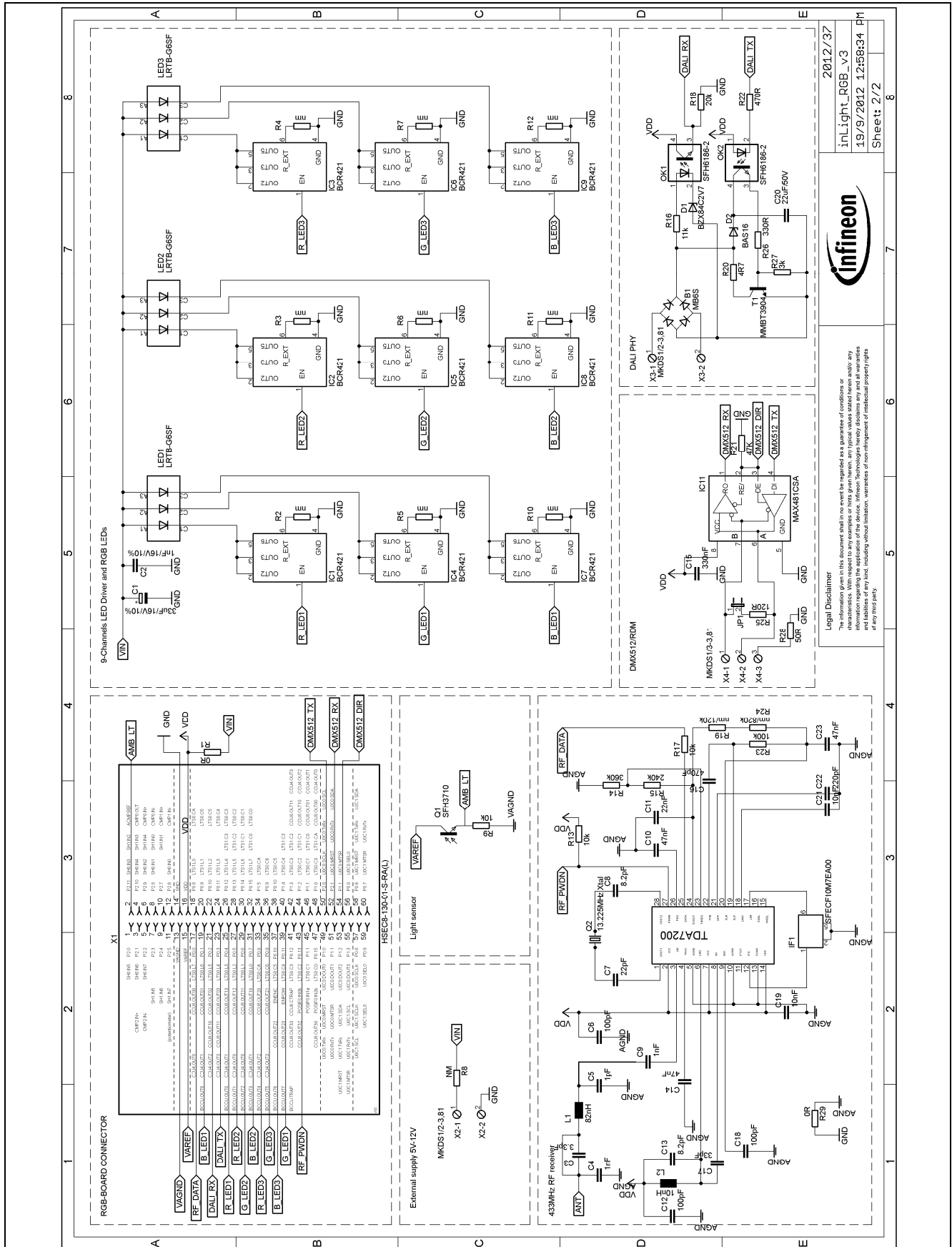

Legal Disclaimer
The information given in this document shall in no event be regarded as a guarantee of conditions or of the results to be obtained from the application of the device. Infineon Technologies hereby disclaims any and all warranties and liabilities of any kind, including without limitation, warranties of non-infringement of intellectual property rights of any third party.

2012/37
inLight_RGB_V3
19/9/2012 12:58:34 PM
Sheet 2/2

Figure 10 Schematic of Colour LED Card

3.2 Layout and Geometry

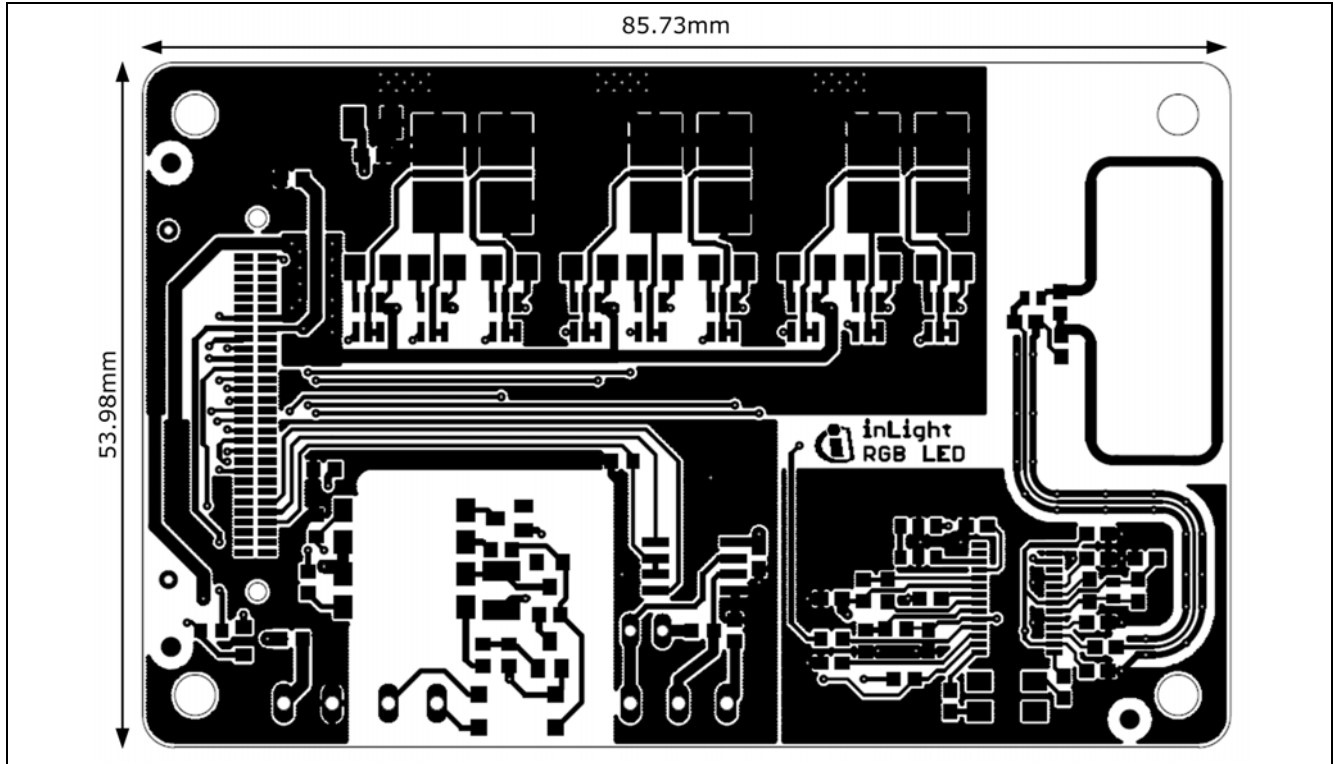

Figure 11 Colour LED Card layout and geometry

3.3 Bill of Materials

Table 7 Colour LED Card BOM

No.	Qty	Value	Device	Reference Designator
1	1	HSEC8-130-01-L-RA	HSEC8 socket, SAMTEC	X1
2	3	MKDS1/2-3,81	3.81mm pitch, 2 way, Phoenix	X2,X3,X4
3	1	MB6S	Bridge Rectifier, Fairchild	B1
4	1	22uF/50V/10%/1210	Capacitor	C20
5	1	33uF/16V/10%/SMC_B	Electrolytic capacitor	C1
6	1	1pF/16V/10%/0603	Capacitor	C5
7	1	3.3pF/16V/10%/0603	Capacitor	C3
8	2	8.2pF/16V/10%/0603	Capacitor	C8,C13
9	1	33pF/16V/10%/0603	Capacitor	C17
10	3	100pF/16V/10%/0603	Capacitor	C6,C12,C18
11	1	220pF/16V/10%/0603	Capacitor	C22
12	1	470pF/16V/10%/0603	Capacitor	C16
13	3	1nF/16V/10%/0603	Capacitor	C2,C4,C9

No.	Qty	Value	Device	Reference Designator
14	2	10nF/16V/10%/0603	Capacitor	C19,C21
15	2	22nF/16V/10%/0603	Capacitor	C7,C11
16	3	47nF/16V/10%/0603	Capacitor	C10,C14,C23
17	1	330nF/10V/10%/0603	Capacitor	C15
18	1	BZX84C2V7/SOT23	Zener diode 2.7V, NXP	D1
19	1	BAS16/TO236	Diode	D2
20	9	BCR421/SC74	LED driver, Infineon	IC1,IC2,IC3,IC4,IC5,IC6,IC7,IC8,IC9
21	1	TDA7200/TSSOP28	ASK/FSK receiver, Infineon	IC10
22	1	MAX481CSA/SO08	RS-485 transceiver, Maxim	IC11
23	1	SFECF10M7EA00	10.7MHz BP filter, Murata	IF1
24	1	2.54mm pitch header, 2way	JUMPER	JP1
25	1	10nH/0603	Inductor	L2
26	1	82nH/0603	Inductor	L1
27	3	LRTB-G6SF/P-LCC-6	RGB LED, OSRAM	LED1,LED2,LED3
28	1	SFH6186-2	Optocoupler, Vishay	OK1,OK2
29	1	SFH3710	Light detector, OSRAM	Q1
30	1	13.225MHz Xtal	Crystal	Q2
31	2	0R/0603	Resistor	R1,R29
32	12	no ass./0603	Resistor	R2,R3,R4,R5,R6,R7,R8,R10,R11,R12,R19,R24
33	3	10K/0603	Resistor	R9,R13,R17
34	1	360K/0603	Resistor	R14
35	1	240K/0603	Resistor	R15
36	1	11K/0603	Resistor	R16
37	1	20K/0603	Resistor	R18
38	1	4R7/0603	Resistor	R20
39	1	47K/0603	Resistor	R21
40	1	470R/0603	Resistor	R22
41	1	100K/0603	Resistor	R23
42	1	120R/0603	Resistor	R25
43	1	330R/0603	Resistor	R26
44	1	3K/0603	Resistor	R27
45	1	50R/0603	Resistor	R28
46	1	MMBT3904/SOT23	NPN Transistor	T1

www.infineon.com

Published by Infineon Technologies AG

X-ON Electronics

Largest Supplier of Electrical and Electronic Components

Click to view similar products for [LED Lighting Development Tools](#) category:

Click to view products by [Infineon](#) manufacturer:

Other Similar products are found below :

[MIC2870YFT EV](#) [ADP8860DBCP-EVALZ](#) [LM3404MREVAL](#) [ADM8843EB-EVALZ](#) [TDGL014](#) [ISL97682IRTZEVALZ](#) [LM3508TLEV](#)
[EA6358NH](#) [TLC5929EVM-118](#) [MAX16826EVKIT](#) [MAX16839EVKIT+](#) [TPS92315EVM-516](#) [MAX6956EVKIT+](#) [OM13321,598](#) [STEVAL-](#)
[LLL006V1](#) [IS31LT3948-GRLS4-EB](#) [PIM526](#) [PIM527](#) [MAX6946EVKIT+](#) [MAX20070EVKIT#](#) [MAX20090BEVKIT#](#)
[DEMOBCR431ULVDROPTOBO1](#) [PIM498](#) [AP8800EV1](#) [ZXLD1370/1EV4](#) [TLC59116EVM-390](#) [1216.1013](#) [TPS61176EVM-566](#)
[TPS61197EVM](#) [TPS61310EVM-638](#) [TPS92001EVM-628](#) [1270](#) [1271.2004](#) [1272.1030](#) [1273.1010](#) [1278.1010](#) [1279.1002](#) [1279.1001](#)
[1282.1000](#) [1293.1900](#) [1293.1800](#) [1293.1700](#) [1293.1500](#) [1293.1100](#) [1282.1400](#) [1282.1100](#) [1293.1200](#) [1282.1200](#) [1293.1000](#) [1282.6000](#)