

# Synchronous Rectified Buck MOSFET driver IC

PX3517

**Datasheet**

Revision 2.4, 2015-10-20

**Power Management and Multimarket**

**Edition 2015-10-20**

**Published by**

**Infineon Technologies AG**

**81726 Munich, Germany**

**© 2015 Infineon Technologies AG**

**All Rights Reserved.**

### **Legal Disclaimer**

The information given in this document shall in no event be regarded as a guarantee of conditions or characteristics. With respect to any examples or hints given herein, any typical values stated herein and/or any information regarding the application of the device, Infineon Technologies hereby disclaims any and all warranties and liabilities of any kind, including without limitation, warranties of non-infringement of intellectual property rights of any third party.

### **Information**

For further information on technology, delivery terms and conditions and prices, please contact the nearest Infineon Technologies Office ([www.infineon.com](http://www.infineon.com)).

### **Warnings**

Due to technical requirements, components may contain dangerous substances. For information on the types in question, please contact the nearest Infineon Technologies Office.

Infineon Technologies components may be used in life-support devices or systems only with the express written approval of Infineon Technologies, if a failure of such components can reasonably be expected to cause the failure of that life-support device or system or to affect the safety or effectiveness of that device or system. Life support devices or systems are intended to be implanted in the human body or to support and/or maintain and sustain and/or protect human life. If they fail, it is reasonable to assume that the health of the user or other persons may be endangered.

**Revision History**

Page or Item	Subjects (major changes since previous revision)
Revision 2.2	2014-03-26/2015-10-20 Conditions for RT pin not used
	→ table 2: pin RT description
	→ paragraph 5.5 Thermal Protection description
Revision 2.3	2014-10-13
	→ R <sub>PHASE</sub> added in the Simplified Block Diagram
	→ SOA diagram for R <sub>PHASE</sub> introduced
Revision 2.4	2015-10-20
	→ Power up and power down sequence introduced
	→ Junction operating temperature from -25°C to -40°C table 1 and table 7

**Trademarks of Infineon Technologies AG**

AURIX™, BlueMoon™, COMNEON™, C166™, CROSSAVE™, CanPAK™, CIPOS™, CoolMOS™, CoolSET™, CORECONTROL™, DAVE™, EasyPIM™, EconoBRIDGE™, EconoDUAL™, EconoPACK™, EconoPIM™, EiceDRIVER™, EUPEC™, FCOS™, HITFET™, HybridPACK™, ISOFACE™, I<sup>2</sup>RF™, IsoPACK™, MIPAQ™, ModSTACK™, my-d™, NovalithIC™, OmniTune™, OptiMOS™, ORIGA™, PROFET™, PRO-SiL™, PRIMARION™, PrimePACK™, RASIC™, ReverSave™, SatRIC™, SIEGET™, SINDRION™, SMARTi™, SmartLEWIS™, TEMPFET™, thinQ!™, TriCore™, TRENCHSTOP™, X-GOLD™, XMM™, X-PMU™, XPOSSYS™.

**Other Trademarks**

Advance Design System™ (ADS) of Agilent Technologies, AMBA™, ARM™, MULTI-ICE™, PRIMECELL™, REALVIEW™, THUMB™ of ARM Limited, UK. AUTOSAR™ is licensed by AUTOSAR development partnership. Bluetooth™ of Bluetooth SIG Inc. CAT-iq™ of DECT Forum. COLOSSUS™, FirstGPS™ of Trimble Navigation Ltd. EMV™ of EMVCo, LLC (Visa Holdings Inc.). EPCOS™ of Epcos AG. FLEXGO™ of Microsoft Corporation. FlexRay™ is licensed by FlexRay Consortium. HYPERTERMINAL™ of Hilgraeve Incorporated. IEC™ of Commission Electrotechnique Internationale. IrDA™ of Infrared Data Association Corporation. ISO™ of INTERNATIONAL ORGANIZATION FOR STANDARDIZATION. MATLAB™ of MathWorks, Inc. MAXIM™ of Maxim Integrated Products, Inc. MICROTEC™, NUCLEUS™ of Mentor Graphics Corporation. Mifare™ of NXP. MIPI™ of MIPI Alliance, Inc. MIPS™ of MIPS Technologies, Inc., USA. muRata™ of MURATA MANUFACTURING CO., MICROWAVE OFFICE™ (MWO) of Applied Wave Research Inc., OmniVision™ of OmniVision Technologies, Inc. Openwave™ Openwave Systems Inc. RED HAT™ Red Hat, Inc. RFMD™ RF Micro Devices, Inc. SIRIUS™ of Sirius Sattelite Radio Inc. SOLARIS™ of Sun Microsystems, Inc. SPANSION™ of Spansion LLC Ltd. Symbian™ of Symbian Software Limited. TAIYO YUDEN™ of Taiyo Yuden Co. TEAKLITE™ of CEVA, Inc. TEKTRONIX™ of Tektronix Inc. TOKO™ of TOKO KABUSHIKI KAISHA TA. UNIX™ of X/Open Company Limited. VERILOG™, PALLADIUM™ of Cadence Design Systems, Inc. VLYNQ™ of Texas Instruments Incorporated. VXWORKS™, WIND RIVER™ of WIND RIVER SYSTEMS, INC. ZETEX™ of Diodes Zetex Limited.

Last Trademarks Update 2010-06-09

## 1 Applications

- Desktop and Server VR11.X and VR12.X Vcore and non-Vcore buck-converters
- Network and Telecom uncontrolled processor VR
- Single Phase and Multiphase POL
- CPU/GPU Regulation in Graphics Cards and Gaming Consoles
- Voltage Regulator Modules requiring high power density
- Memory (DDR2/3)

## 2 Features

- High frequency operation up to 1.2MHz
- Capability to drive MOSFET at 50A continuous current per phase
- Wide driving input voltage range from 4.5V to 9V
- Adjustable thermal warning
- Thermal warning report function
- Wide input voltage range: up to 16V
- Low power dissipation
- Includes bootstrap diode
- Adaptive shoot through protection
- Compatible with standard +3.3V PWM controller ICs
- Tri-state PWM input functionality
- Small package: 3mm x 3mm TDSON-10
- RoHS compliant

**Table 1 Product Identification**

Part Number	Temperature Range	Package	Marking
PX3517	-40 to 125°C	3x3 10-leads TDSON-10	3517

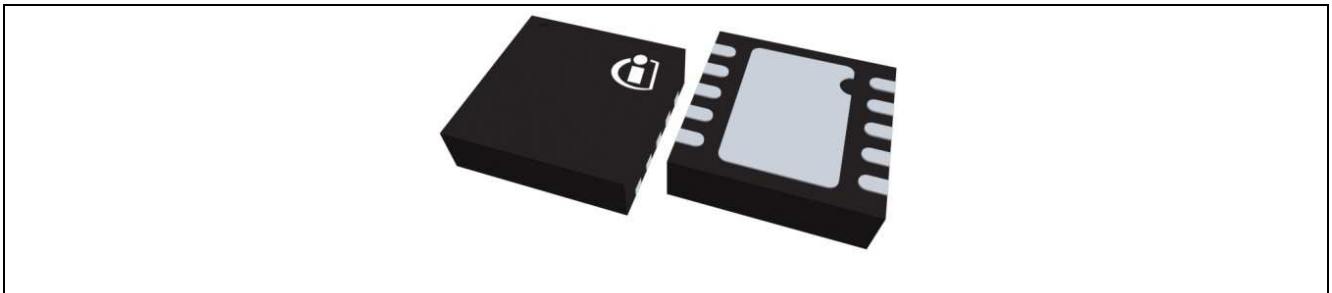
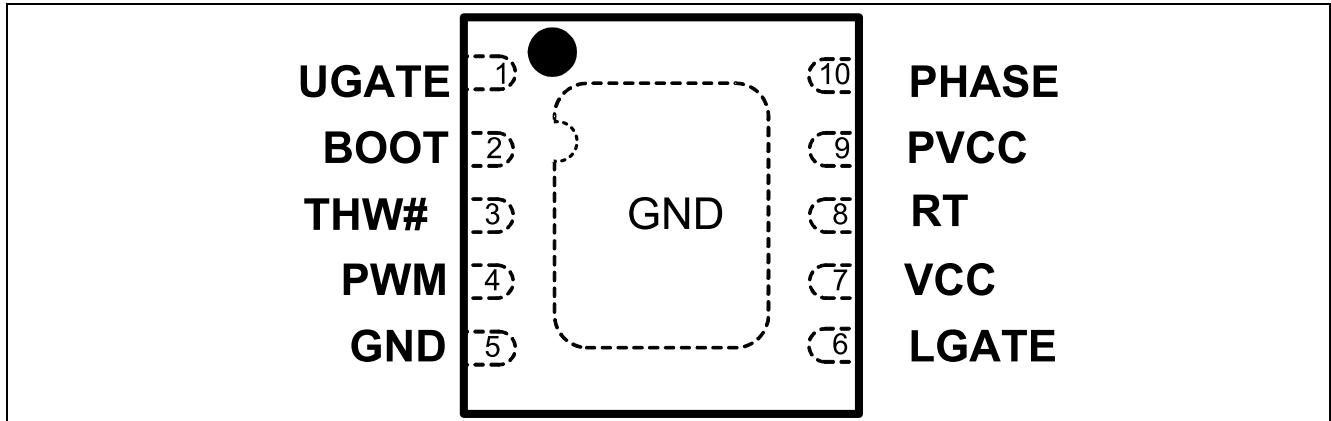

**Figure 1 Picture of the product**



### 3 Description

#### 3.1 Pinout



**Figure 2** Pinout, numbering and pin names (transparent top view)

Note: Signals marked with “#” are active low.

**Table 2** I/O Signals

Pin No.	Name	Pin Type	Buffer Type	Function
1	UGATE	O	Analog	<b>Upper gate drive output</b> Connect to high side N-channel power MOSFET gate.
2	BOOT	O	Analog	<b>Floating bootstrap supply pin for upper gate drive</b> Connect the bootstrap capacitor <sup>1</sup> between this pin and the PHASE pin. The bootstrap capacitor provides the charge to turn on the upper MOSFET. See the Internal Bootstrap Device section herein for guidance in choosing the capacitance value.
3	THW#	O	Analog	<b>Open drain output</b> Connect this pin to 3.3V through a resistor <sup>2</sup> . Once the thermal protection threshold is tripped, the THW# pin is pulled down. Leave open if not used.
4	PWM	I	3.3V Logic	<b>PWM drive logic input</b> Connect this pin to the PWM out from the controller IC.
6	LGATE	O	Analog	<b>Lower gate drive output</b> Connect to low side N-channel power MOSFET gate.
8	RT	O	Analog	<b>Thermal warning threshold selection pin</b> Connect this pin to an external resistance <sup>2</sup> to GND. Used to set the thermal warning threshold. If not used it can be left floating.
10	PHASE	I	Analog	<b>Return path for high side MOSFET driver</b> Connect this pin to the source of the upper MOSFET and the drain of the lower MOSFET. This pin provides a return path for the upper gate drive.

<sup>1</sup> See section 5.2 for guidance in choosing capacitance value

<sup>2</sup> See section 5.5 for resistor value selection

**Table 3 Power Supply**

Pin No.	Name	Pin Type	Buffer Type	Function
7	VCC	POWER	-	<b>Supply for IC housekeeping and logic</b> Connect to +4.5V-8V power supply. Place a high quality low ESR ceramic capacitor from this pin to GND.
9	PVCC	POWER	-	<b>Supply for IC driver section</b> Connect this pin to +4.5V-8V power supply.

**Table 4 Ground Pins**

Pin No.	Name	Pin Type	Buffer Type	Function
5	GND	GND	-	<b>GND connection</b> Can be left open since main GND connection to circuit board is established by die pad. Cannot be used as sole ground connection (does not replace die pad ground).
-	Die Pad	GND	-	<b>Bias and reference ground</b> All signals are referenced to this node. It is also the power ground return for the driver. It is mandatory to connect the die paddle electrically and thermally to the circuit board.

### 3.2 General Description

The PX3517 is a dual, high speed driver designed to drive a wide range of high side and low side N-channel power MOSFETs in synchronous rectified buck converters. When combined with the Primarion family of Digital Multi-phase Controller ICs or Digital Point of Load Controller ICs and Infineon N-channel MOSFET products, the PX3517 forms a complete core-voltage regulator solution for advanced micro and graphics processors as well as point-of-load applications. VCC and PVCC can be tied together and supplied by a voltage ranging between 4.5V and 8V. They can be separated for better noise decoupling of the logic section (VCC) from the power section (PVCC). They can also be supplied with different voltages, but in this case the appropriate power up/down sequence has to be implemented. PVCC provides the capability of driving the high side MOSFET gate and low side MOSFET gate with a variable gate driving voltage to tailor efficiency based on customer conditions. Adaptive shoot-through protection is integrated into the IC. This prevents both upper and lower MOSFETs from conducting simultaneously and minimizes dead time. A thermal warning function with an adjustable threshold, set by an external resistance, is featured to protect the system from thermal issues. Once the junction temperature of the PX3517 encounters the thermal warning threshold the driver outputs a logic signal through the open drain THW# pin.



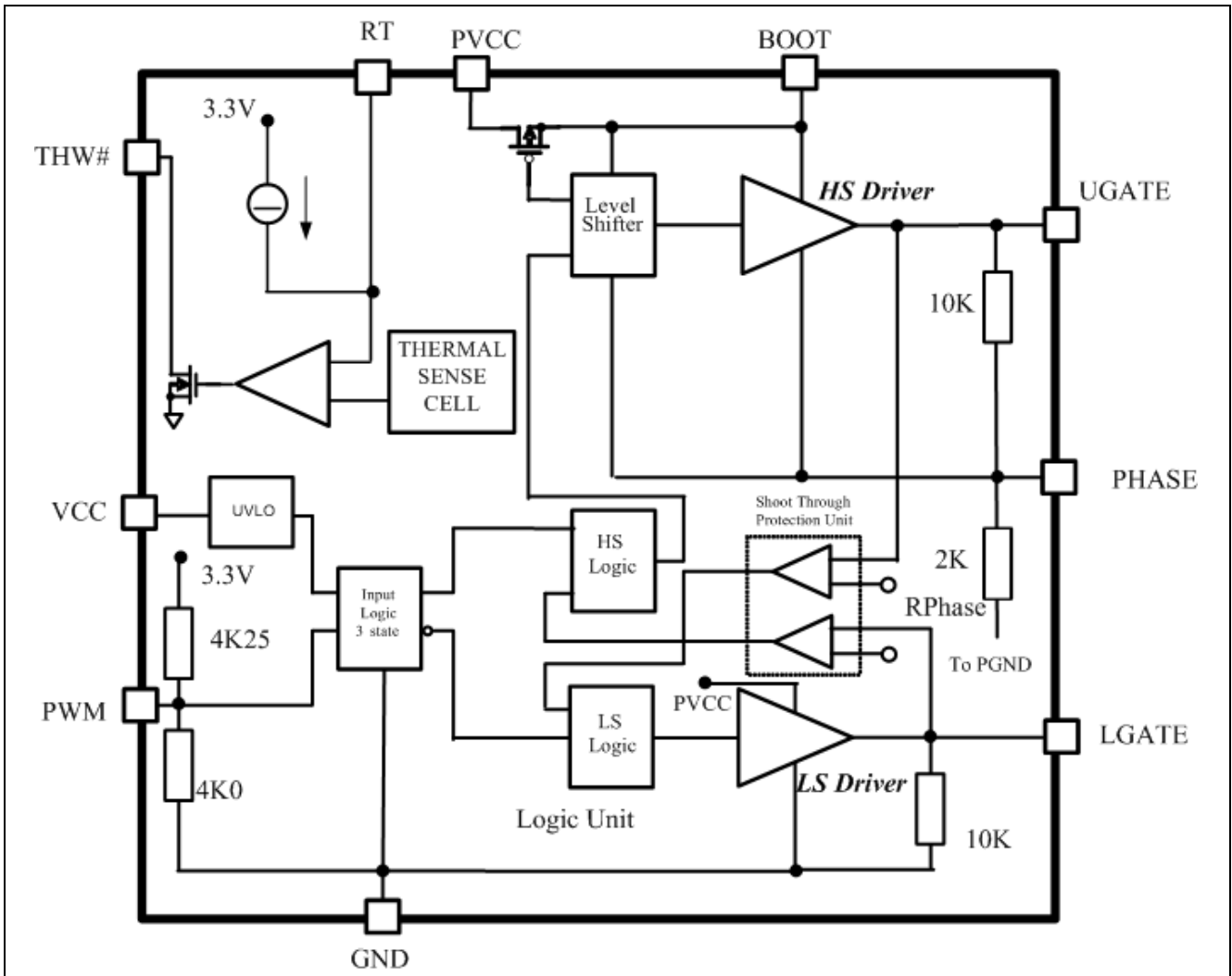

Figure 3 Simplified block diagram

## 4 Electrical specification

### 4.1 Absolute Maximum Ratings

Stresses above those listed in Table 5 "Absolute Maximum Ratings" may cause permanent damage to the device. These are absolute stress ratings only and operation of the device is not implied or recommended at these or any other conditions in excess of those given in the operational sections of this specification. Exposure to the absolute maximum ratings for extended periods may adversely affect the operation and reliability of the device.

**Table 5 Absolute Maximum Ratings ( $T_{\text{ambient}} = 25^{\circ}\text{C}$ )**

Parameter	Symbol	Values			Unit	Note / Test Conditions
		Min.	Typ.	Max.		
VCC PVCC supply voltage (DC)	$V_{\text{VCC}}, V_{\text{PVCC}}$	-0.3	–	9	V	
THW#	THW#	-0.3	–	3.6	V	
BOOT voltage	$V_{\text{BOOT}}$	-0.3	–	30	V	
BOOT to PHASE voltage	$V_{\text{BOOT}} - V_{\text{PHASE}}$	-0.3	–	9	V	
PHASE voltage, DC	$V_{\text{PHASE}}$	-1	–	16	V	
PHASE voltage, pulsed	$V_{\text{PHASE}}$	-8	–	25	V	<sup>3)</sup>
$V_{\text{PWM}}$		–	–	3.6	V	
RT	$V_{\text{RT}}$	–	–	3.6	V	
Junction temperature	$T_{\text{Jmax}}$	-40	–	150	$^{\circ}\text{C}$	–
Storage temperature	$T_{\text{STG}}$	-55	–	150	$^{\circ}\text{C}$	–

<sup>3)</sup> The pulse duration is 10ns.

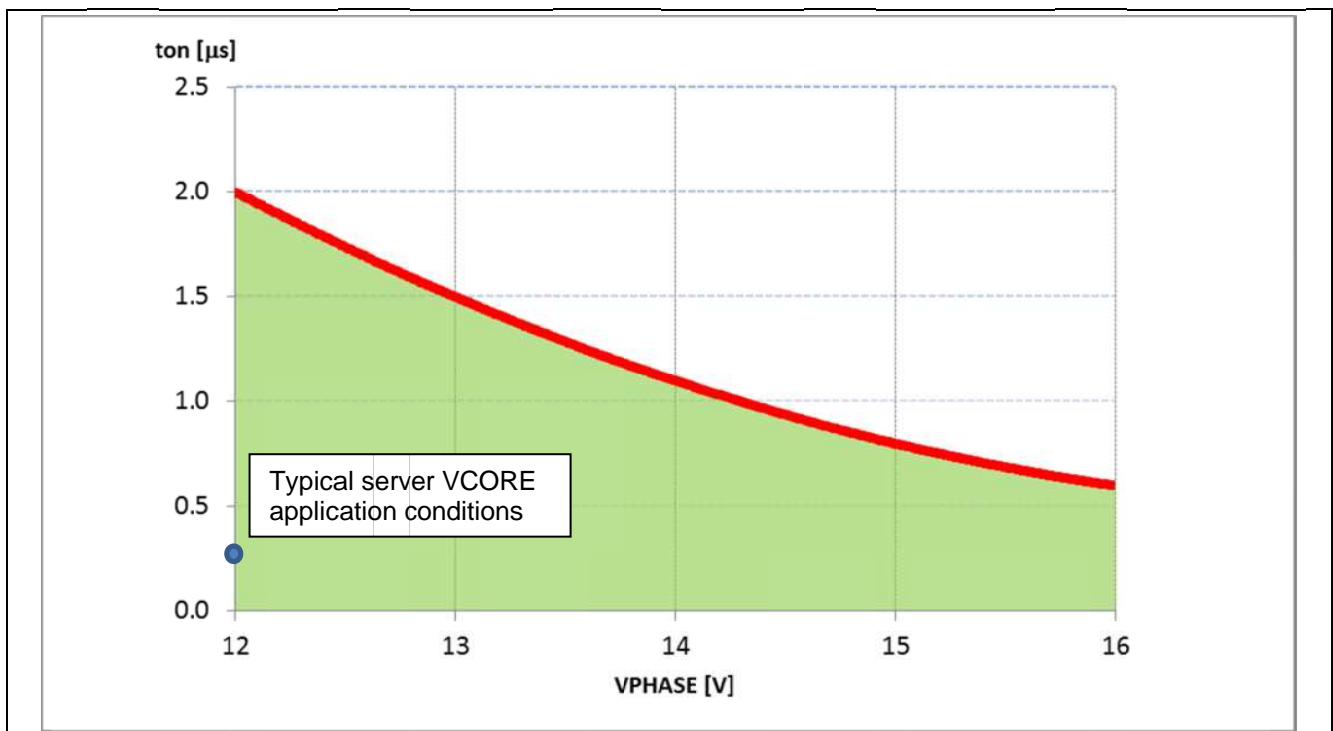

**Figure 4 Safe Operating Area of  $R_{\text{PHASE}}$**



*Note:  $t_{on}$  refers to the on-time of the HS-MOSFET. For input voltages below 12 V no limits on the duration of  $t_{on}$  need to be applied. The relative position of a typical Server VCORE application conditions  $V_{IN}=12V$   $V_{OUT}=1.8V$   $f_{SW}=450kHz$  is represented as reference. This Safe Operating Area is verified by design, not 100% tested in production.*

*Note: All rated voltages are relative to voltages on the GND pins unless otherwise specified.*

## 4.2 Thermal Characteristics

**Table 6 Thermal Characteristics**

Parameter	Symbol	Values			Unit	Note / Test Condition
		Min.	Typ.	Max.		
Thermal resistance, junction-soldering point <sup>3</sup>	$\theta_{JS}$	-	7	-	K/W	-
Thermal resistance, junction-top of package	$\theta_{Jtop}$	-	20	-		-

## 4.3 Recommended Operating Conditions and Electrical Characteristics

Note:  $PVCC = VCC = 5V$ ,  $T_{ambient} = 25^{\circ}C$

**Table 7 Recommended Operating Conditions**

Parameter	Symbol	Values			Unit	Test conditions
		Min.	Typ.	Max.		
MOSFET driver voltage	$V_{PVCC}$	4.5	-	8.0	V	-
Logic supply voltage rising edge between 3.1V and 4.5V : $dv_{CC}/dt > 5V/100ms$	$V_{VCC}$	4.5	-	8.0		-
Frequency of the PWM	$f_{SW}$			1.2	MHz	Note4
Junction temperature	$T_{jOP}$	-40		+125	$^{\circ}C$	-
Minimum on time			20		ns	Note4
Minimum off time			30		ns	Note4

**Table 8 Voltage Supply And Biasing Current**

Parameter	Symbol	Values			Unit	Test conditions
		Min.	Typ.	Max.		
UVLO rising rising edge between 3.1V and 4.5V : $dv_{CC}/dt > 5V/100ms$	$V_{UVLO\_R}$	-	3.6	4.5	V	VCC rising
UVLO falling	$V_{UVLO\_F}$	-	3.2	-		VCC falling
Driver current	$I_{PVCC\_300kHz}$	-	2	-	mA	$f_{SW} = 300kHz$
	$I_{PVCC\_PWML}$	-	670	-	$\mu A$	PWM = 0V
IC current (control)	$I_{VCC\_PWML}$	-	1.05	-	mA	PWM = 0V
	$I_{VCC\_O}$	-	660	-	$\mu A$	PWM = Open

<sup>3</sup> The junction-soldering point is referred to the GND bottom exposed pad.

**Table 9 Logic Inputs And Threshold**

Parameter		Symbol	Values			Unit	Test conditions
			Min.	Typ.	Max.		
THW#	Programmable Warning Temperature range		70	–	130	°C	
	Thermal warning accuracy		-10	–	+10		
	Hysteresis		–	10	–		
	On resistance		–	37.5	80	Ω	I <sub>LOAD</sub> = 8mA
	Leakage current		–	0.1	5	μA	
PWM	Input low	V <sub>PWM_L</sub>	–	–	0.8	V	V <sub>PWM</sub> falling
	Input high	V <sub>PWM_H</sub>	2.5	–	–		V <sub>PWM</sub> rising
	Input resistance	R <sub>IN-PWM</sub>	–	2.06	–	kΩ	V <sub>PWM</sub> = 1 V
	Open voltage	V <sub>PWM_O</sub>	–	1.6	–	V	V <sub>PWM_O</sub>
	Tri-state shutdown window	V <sub>PWM_S</sub>	1.2	–	2.0		–

**Table 10 Timing Characteristics**

Parameter		Symbol	Values			Unit	Test conditions
			Min.	Typ.	Max.		
<b>Upper Gate (UGATE) Output</b>							
Shutdown hold off time	t <sub>SSHD_U</sub>		50			ns	No load
UGATE rise time	t <sub>r_U</sub>		10				Note <sup>4</sup> , 3nF load
UGATE fall time	t <sub>f_U</sub>		10				Note <sup>4</sup> , 3nF load
Tri-state to high propagation delay	t <sub>PDTS_U</sub>		15				No load
UGATE turn-on propagation delay	t <sub>PDH_U</sub>		15				No load
UGATE turn-off propagation delay	t <sub>PDL_U</sub>		20				No load
<b>Lower Gate (LGATE) Output</b>							
Shutdown hold-off time	t <sub>SSHD_L</sub>		50			ns	No load
LGATE rise time	t <sub>r_L</sub>		10				Note <sup>4</sup> , 3nF load
LGATE fall time	t <sub>f_L</sub>		5				Note <sup>4</sup> , 3nF load
Tri-state to low propagation delay	t <sub>PDTS_L</sub>		15				No load
LGATE turn-on propagation delay	t <sub>PDH_L</sub>		15				No load
LGATE turn-off propagation delay	t <sub>PDL_L</sub>		7				No load
<b>Thermal warning</b>							
Thermal warning propagation delay	t <sub>D_THW#</sub>				10	μs	

<sup>4</sup> Parameter verified by design, not 100% tested in production.

Table 11 Output Characteristics

Parameter	Symbol	Values			Unit	Test conditions
		Min.	Typ.	Max.		
<b>Output Characteristics</b>						
Upper drive source current	$I_{SRC\_UG}$		2		A	Note4, current pulse < 20ns
Upper drive source impedance	$R_{SRC\_UG}$		0.8		$\Omega$	$I_{SRC\_UG} = 200\text{mA}$
Upper drive sink current	$I_{SNK\_UG}$		2		A	Note4, current pulse < 20ns
Upper drive sink impedance	$R_{SNK\_UG}$		0.6		$\Omega$	$I_{SNK\_UG} = 200\text{mA}$
Lower drive source current	$I_{SRC\_LG}$		2		A	Note4, current pulse < 40ns
Lower drive source impedance	$R_{SRC\_LG}$		0.8		$\Omega$	$I_{SRC\_UG} = 200\text{mA}$
Lower drive sink current	$I_{SNK\_LG}$		4		A	Note4, current pulse < 40ns
Lower drive sink impedance	$R_{SNK\_LG}$		0.35		$\Omega$	$I_{SNK\_UG} = 200\text{mA}$

## 5 Theory of Operation

The PX3517 functionality is enabled by the VCC pin. When the VCC pin voltage overcomes the VCC rising voltage threshold, the driver begins to operate depending on the PWM status. Before the VCC pin voltage reaches the VCC rising threshold both MOSFETs are kept in the OFF state. For VCC is recommended to have a slope for the rising edge higher than 5V/100ms around the rising UVLO threshold.

The PX3517 functionality is driven by PWM signal transitions. When the PWM signal performs a transition from low state to high state (PWM voltage higher than 2.5V typ) the low side MOSFET is turned off, after the turn off propagation delay time. Next the high side MOSFET is turned on, after the turn on propagation delay time. Once the on time has expired, the PWM signal provides a transition from high state to low state (PWM voltage lower than 0.8V typ). This will drive the high side MOSFET from the ON state to the OFF state, after the turn off propagation delay time. The PX3517 is also capable of driving two external MOSFETs into the OFF state. When the PWM signal level enters the shut down window or tri-state (typically between 1.2V and 2V), after the shut down hold off time has expired, both MOSFETs are switched off. This feature is useful when the IC controller wants to reduce the number of active phases in order to decrease power consumption. In principle the tri-state can also be used to improve performance during transitions between heavy and light loads.

The PX3517 implements an embedded resistor network, which forces the PWM pin voltage of the device into the middle of the shut down window if the PWM input is left floating by the controller IC.

An adaptive anti-shoot-through control scheme is implemented in order to avoid cross conduction between the high side MOSFET and the low side MOSFET. This adaptive scheme allows for the use of a variety of different power MOSFETs for different kinds of power conversion. Nevertheless, the dead time is kept as short as possible in order to maximize the efficiency of the overall solution.

The adaptive cross conduction protection is based on the gate-to-source voltage level of the MOSFETs during turn off. When the PWM signal goes low, the high side MOSFET will begin to turn off. Once the  $V_{GS}$  of the high side MOSFET is discharged below 1V, the low side MOSFET will begin to turn on.

When the PWM signal goes high, the low side MOSFET will begin to turn off. Once the  $V_{GS}$  of the low side MOSFET is discharged below 1V, the high side MOSFET will begin to turn on.

There is an additional control mechanism on the PHASE pin that forces the turn on of the low side MOSFET if the PHASE pin is not actively held high. This ensures that the converter will sink current efficiently, and that the bootstrap capacitor will be refreshed appropriately during each switching cycle.

During start up it is possible for the 12V conversion input to rise before the 5V input. In this case, the high side MOSFET can have an induced turn on through the CGD/CGS partition. In order to avoid this undesirable effect the PX3517 embeds a resistance of 10k $\Omega$  between UGATE pin and PHASE pin.

The PX3517 features adjustable thermal warning protection. The thermal warning trip point ranges from 70°C to 130°C, and is selected according to a resistance between the RT pin and GND pin. An embedded thermal sense element senses the driver temperature and compares it to the trip point. Once the two temperatures match, a logical signal is issued by the THW# pin. In this case the driver system does not shut down. The thermal warning has a hysteresis of 10°C. Once the temperature reaches the threshold determined by the external resistance, the THW# will be de-asserted if the temperature drops below the threshold by 10°C.

### 5.1 Driver Characteristics

The gate driver of the PX3517 has 2 voltage inputs, VCC and PVCC. VCC is the logic supply for the driver. PVCC is used to drive the high and low side MOSFETs. Ceramic capacitors should be placed very close to these input voltage pins to decouple the sensitive control circuitry from a noisy environment.

Since two different pins are provided for supplying the power to the driver, the correct power up/down sequence has to be considered. In order to avoid false turn on of the gates (spurious high side turn on, for instance) it is strongly suggested to ensure that the voltage at the VCC pin reaches the UVLO threshold earlier than the PVCC pin. In this way the logic section will ensure the correct functionality of the power section.

Proper response of the driver to the PWM signal is only guaranteed when UVLO have been cleared by the respective supply voltages (ref to table 8).

Therefore, it is strongly recommended to only issue pulses to PWM when no UVLO conditions are present. The power down sequence should set PWM to HiZ with respect the internal threshold, before ramping down VIN (see figure 7 for VIN connection), PVCC and VCC respectively.

The MOSFETs selected for this application are optimized for 5V gate drive, giving the end user optimized efficiency at both high load and light load. Nevertheless the driving voltage (PVCC) can be increased, (independently from VCC), up to 8V in order to have a customized efficiency curve depending on application conditions. The reference for the power circuitry including the driver output stage and the reference for the gate driver control circuit is CGND.

Referring to the block diagram in Figure 3 on page 7, VCC is internally connected to the UVLO circuit. For VCC voltages less than the 3.6V (typ.) required for proper circuit operation, the UVLO circuit will perform a system shut-down. PVCC supplies both the floating high side MOSFET driver and the low side MOSFET driver circuits. An active boot circuit for the high side MOSFET gate drive is also included. A second UVLO circuit, sensing the BOOT voltage level, is implemented to prevent false UGATE turn on during insufficient power supply level conditions (BOOT Cap charging/discharging sequence). During such an undervoltage condition both UGATE and LGATE are driven low actively. Further, a passive pull-down (10kΩ) is placed on each gate.

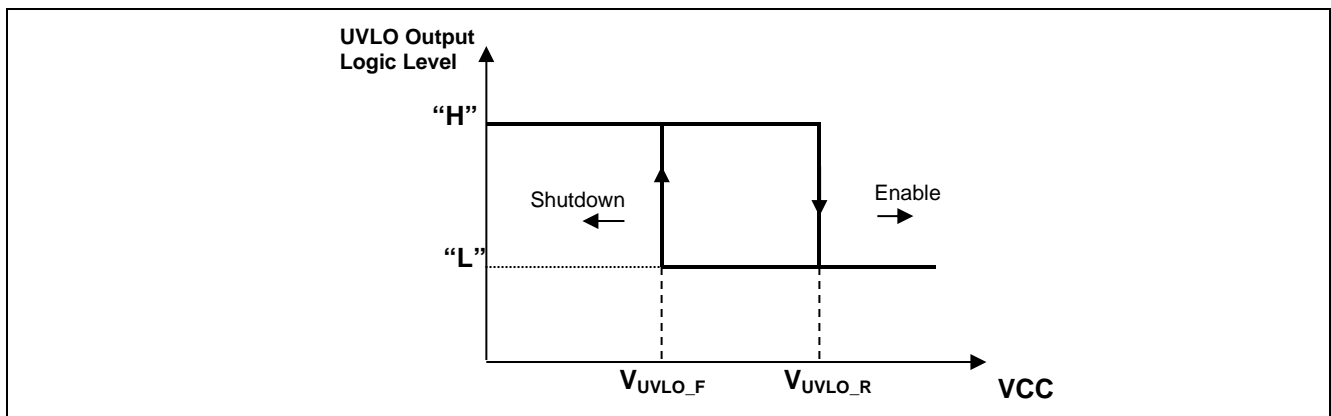

Figure 5 Internal output signal from UVLO unit

## 5.2 Current Capability and Internal Bootstrap

The PX3517 implements high current capability and low ohmic pull down resistances for the driving stages. The high current capability ensures fast switching transition for the MOSFETs. This reduces the switching losses (2A of driving source/sink current for the upper MOSFET) even with high gate charge high side MOSFETs. The low ohmic pull down resistance (lower drive sink impedance 0.35Ω) prevents induced turn on phenomenon of the low side MOSFET during the fast turn on of the high side MOSFET.

The high side MOSFET is powered through the bootstrap circuitry. The PX3517 provides an embedded bootstrap diode, so to complete the power network only a capacitance between the PHASE pin and the BOOT pin is needed. In many cases the PX3517 is optimized for the best switching behavior, so an external resistance is not needed. The bootstrap capacitance is chosen depending on the high side MOSFET gate charge. The following formula gives a good estimation of the voltage drop across the bootstrap capacitance due to the charging of the high side MOSFET.

$$C_{BOOT} > Q_{G\_HS} / \Delta V_{BOOT}$$

$\Delta V_{BOOT}$  is the desired variation of the bootstrap voltage. This should generally be as low as possible in order to avoid high side MOSFET R<sub>DS(on)</sub> drop. Generally, a value between 0.1V and 0.01V is acceptable.

The low side MOSFET driver is powered through the PVCC pin. The same considerations and formula for the bootstrap capacitance can be applied to the capacitance used to filter the PVCC pin.

The flexibility to adjust the driving voltage from 4.5V to 8V gives designers the capability to shape the efficiency curve in any way that is desired.



### 5.3 Power Dissipation

The power dissipation of the driver is given by the gate charge of the external power MOSFETs. The following formulas held:

$$P_{DISS} = P_{VCC} * f_{SW} * (Q_{GS\_HS} + Q_{GS\_LS})$$

$f_{SW}$  is the switching frequency and  $Q_{GHS}$  and  $Q_{GLS}$  are respectively the gate charge of the high side MOSFET and the gate charge of the low side MOSFET at the  $PVCC$  driving voltage. The very low thermal resistance package used for the PX3517 allows the device to avoid any usage of external resistances to decrease the power dissipation inside the driver even with high driving voltage. Since the thermal resistance is strongly influenced by the number of layers used in the board, it is recommended to roughly check the expected junction temperature via the power calculation.

### 5.4 Inputs to the Internal Control Circuits

The PWM is the control input to the IC from an external PWM controller IC and is compatible with 3.3V.

The PWM input has tri-state functionality. When the voltage remains in the specified PWM shutdown window for at least the PWM shutdown holdoff time  $t_{tsshd}$ , operation is suspended by keeping both MOSFET gate outputs low. If left open, the pin is internally fixed to  $V_{PWM\_O} = +1.6V$  level.

During the power-up sequence, the initial state of the PWM signal is ignored, until the first rising edge.

Since all the thresholds are derived from an internal linear regulator they will not depend on the VCC input.

**Table 12 PWM Pin Functionality**

PWM logic level	Driver output
Low	LGATE= High, UGATE = Low
High	LGATE = Low, UGATE = High
Open (left floating, or High impedance)	LGATE = Low, UGATE = Low

### 5.5 Thermal Protection

The THW# pin offers the possibility to check when the temperature of the driver overcomes the threshold fixed by the RT pin resistor. Once the temperature of the driver matches the trip point this open drain output (pulled up to 3.3V by, for instance, an external resistance in the range of 10kΩ) is pulled to zero (active low) with a typical resistance of 37Ω. When the temperature of the device goes below the thermal warning minus the hysteresis (10°C typ), the pin THW# is released and pulled up by the external resistance. If the thermal warning is not used, then leave the pin floating. The thermal warning protection does not switch off the driver.

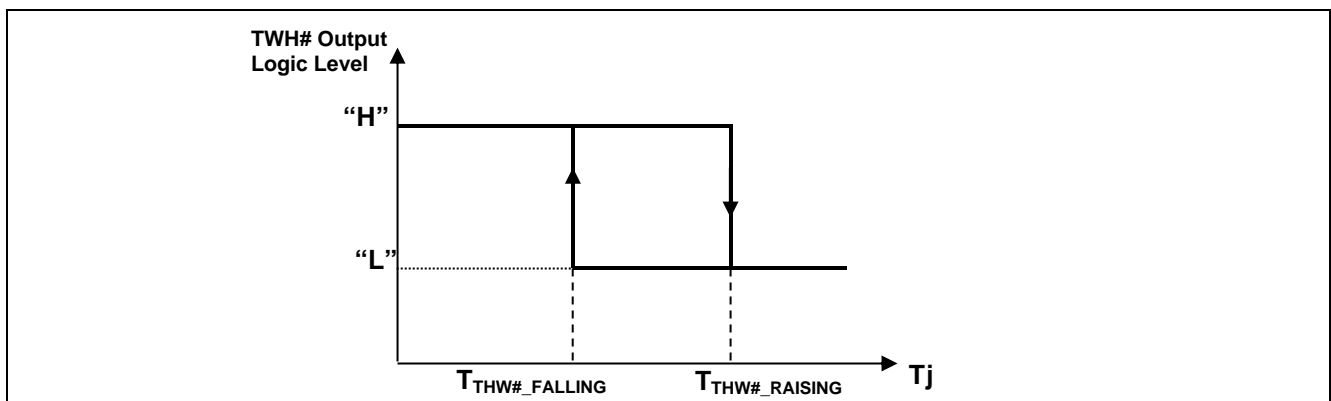

**Figure 6 Thermal warning**

The RT pin provides the option to program the trip point of the thermal warning as follows:

$$r_{RT}(\Omega) = 248 * (T - 70) + 82,000\Omega$$

T is the desired warning temperature. If the threshold is fixed to  $T=100^{\circ}\text{C}$  then the  $\Delta T$  is  $30^{\circ}\text{C}$  and external resistance is equivalent to  $89.5\text{k}\Omega$ , as shown in the following table.

Desired warning temperature [ $^{\circ}\text{C}$ ]	Resistance connected to the RT pin [ $\Omega$ ]
70	82000
80	84400
90	87000
100	89500
110	92000
120	94400
130	96880

The adjustability of the thermal warning should compensate the fact that the sensing point on the driver can be slightly different from the hot spot of the application. In this case a gap between the temperature of the hot spot and the temperature of the driver can be measured and then the thermal warning can be designed with an offset to compensate for the difference.

In order to have better temperature matching it is strongly recommended to connect the GND exposed pad of the driver as near as possible to the hot spot.

If the thermal protection is not used the RT pin can be left floating.

## 5.6 Layout Considerations

The PX3517 has a good protection system against unwanted overshoot and undershoot; the PHASE pin can range between dynamically from  $-8\text{V}$  to  $25\text{V}$ .

The parasitic inductances of the PCB and of the power devices' packaging (both upper and lower MOSFETs) can cause serious ringing, exceeding absolute maximum rating of the devices. Careful layout can help minimize such unwanted stress. The following advice is meant to lead to an optimized layout:

Keep decoupling loops (PVCC-GND and BOOT-PHASE) as short as possible.

Minimize trace inductance, especially on low impedance lines. All power traces (UGATE, PHASE, LGATE, GND, PVCC) should be short and wide, as much as possible.

The PHASE node should also be short and wide. Minimize the distance between the PHASE node and both the high side MOSFET source and the low side MOSFET drain to avoid efficiency losses.

Minimize the current loop of the output and input power trains. Short the source connection of the lower MOSFET to ground as close to the transistor pin as feasible. Input capacitors (especially ceramic decoupling) should be placed as close to the drain of upper and source of lower MOSFETs as possible.

To optimize heat spreading, copper should be placed directly underneath the IC whether it has an exposed pad or not. The copper area can be extended beyond the bottom area of the IC and/or connected to buried copper plane(s) with thermal vias. This combination of vias for vertical heat escape, extended copper plane, and buried planes for heat spreading allows the IC to achieve its full thermal potential.

## 6 Application

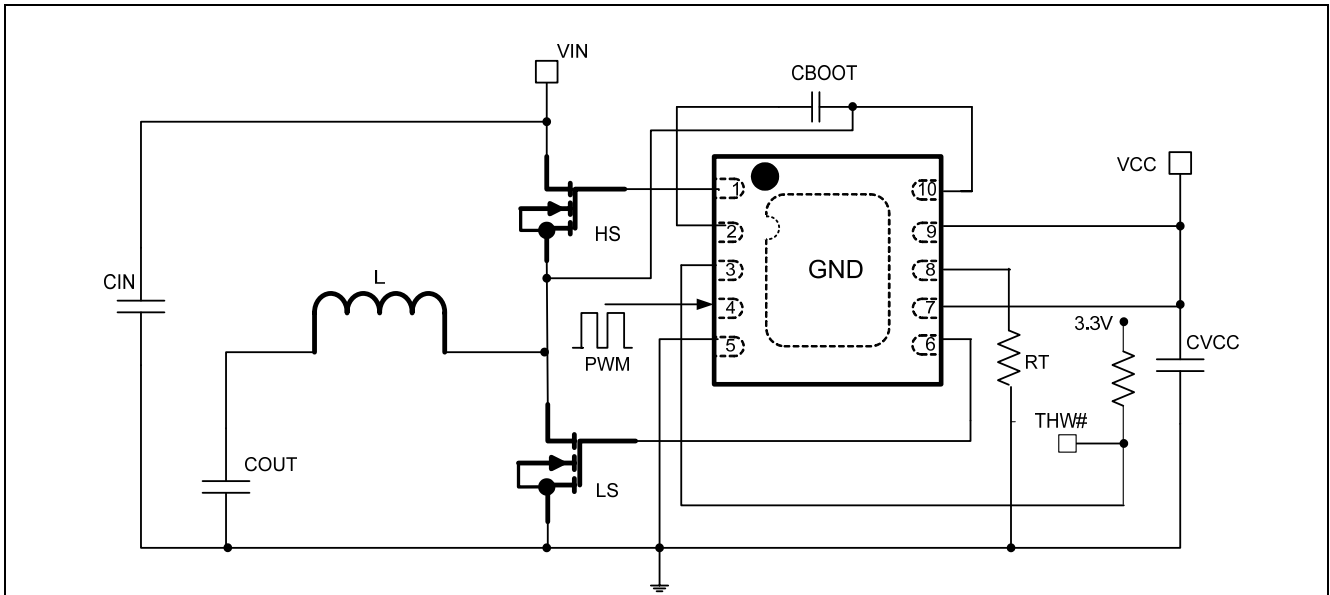

Figure 7 Pin interconnection outline (transparent top view)

## 7 Gate Driver Timing Diagram

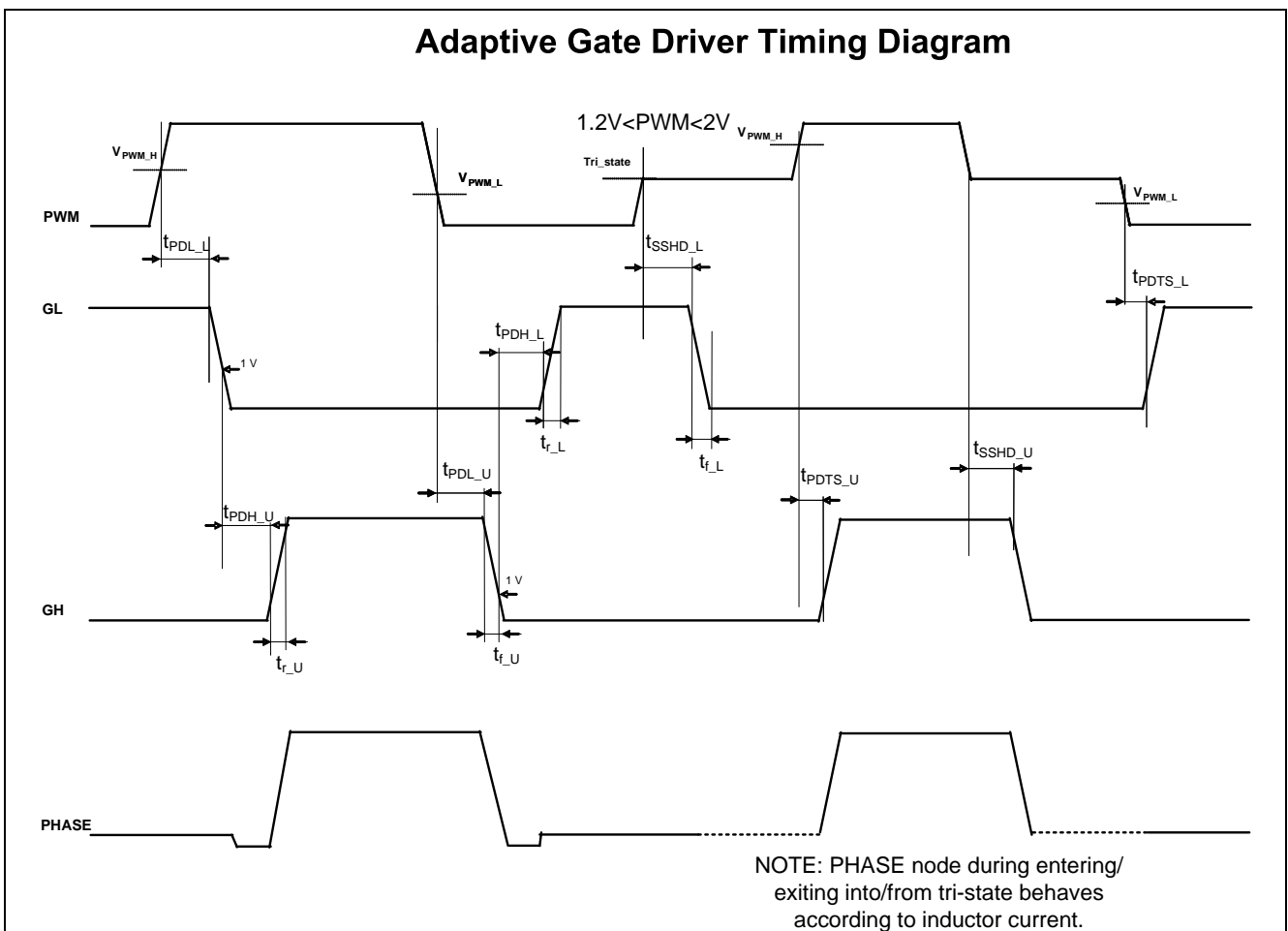

Figure 8 Adaptive gate driver timing diagram

## 8 Mechanical Drawing

All dimensions in mm.

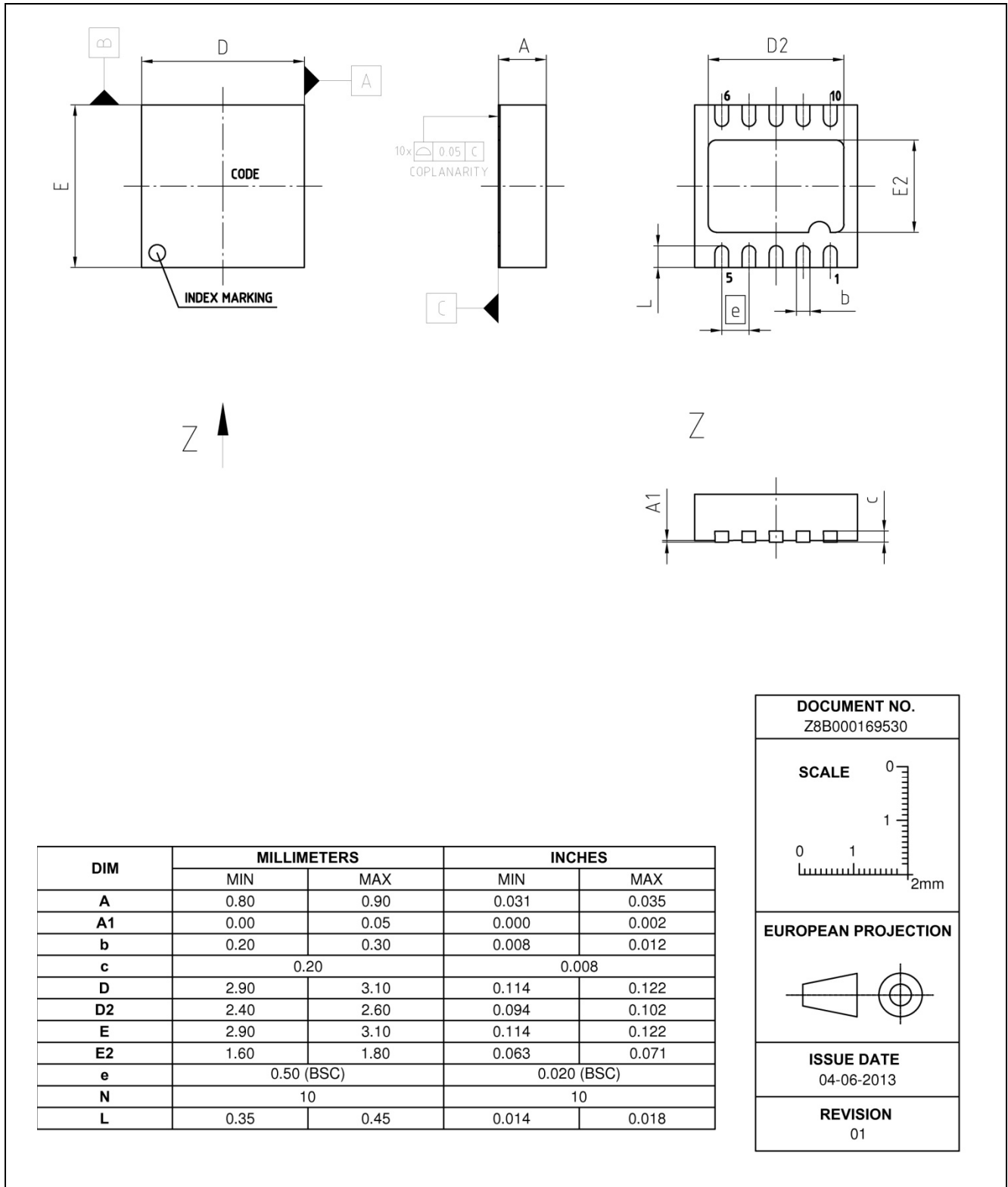

Figure 9 Mechanical dimensions

All dimensions in mm.

## 9 Footprint

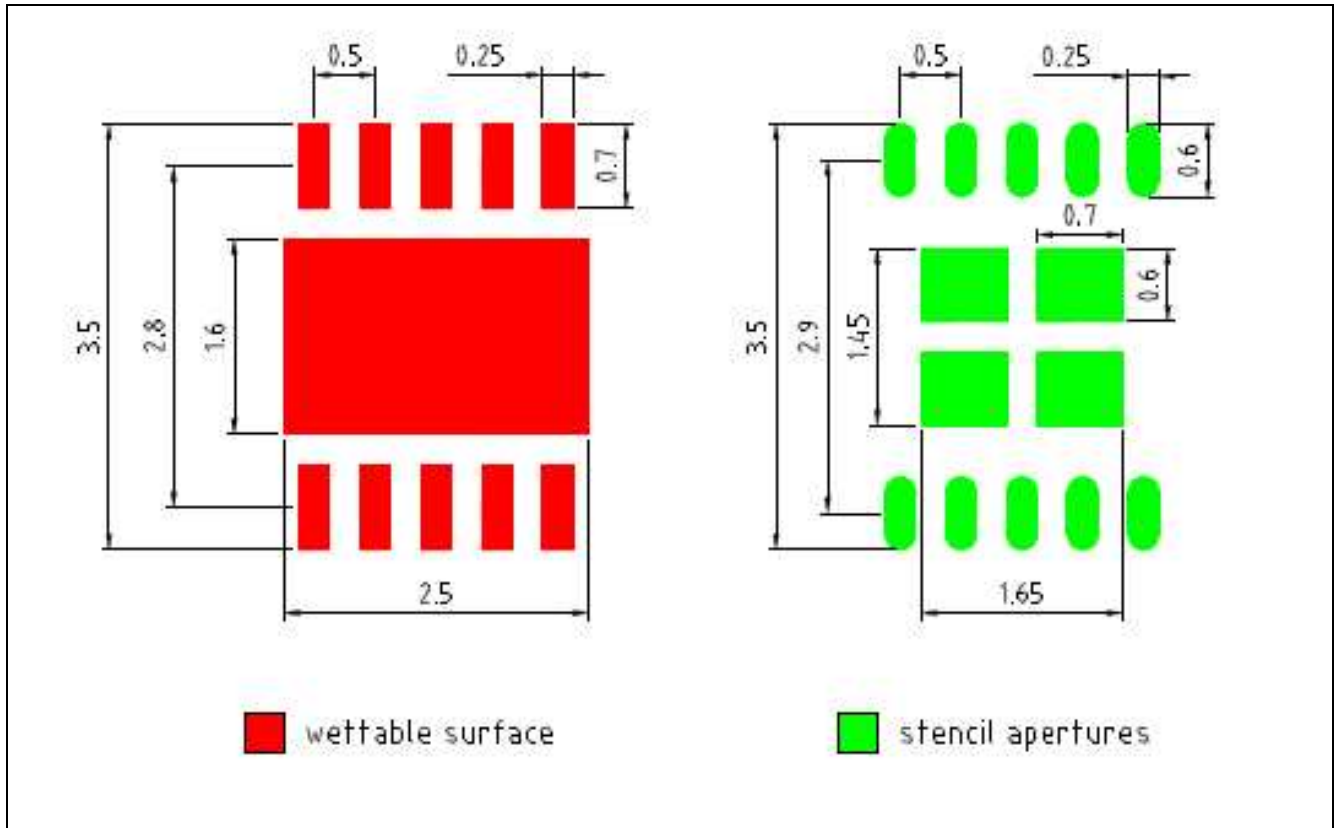

Figure 10 Footprint

[www.infineon.com](http://www.infineon.com)

Published by Infineon Technologies AG



## X-ON Electronics

Largest Supplier of Electrical and Electronic Components

*Click to view similar products for [Gate Drivers](#) category:*

*Click to view products by [Infineon](#) manufacturer:*

Other Similar products are found below :

[00053P0231](#) [56956](#) [57.404.7355.5](#) [LT4936](#) [57.904.0755.0](#) [5882900001](#) [00600P0005](#) [00-9050-LRPP](#) [00-9090-RDPP](#) [5951900000](#) [01-1003W-10/32-15](#) [0131700000](#) [00-2240](#) [LTP70N06](#) [LVP640](#) [5J0-1000LG-SIL](#) [LY1D-2-5S-AC120](#) [LY2-US-AC240](#) [LY3-UA-DC24](#) [00576P0020](#) [00600P0010](#) [LZN4-UA-DC12](#) [LZNQ2M-US-DC5](#) [LZNQ2-US-DC12](#) [LZP40N10](#) [00-8196-RDPP](#) [00-8274-RDPP](#) [00-8275-RDNP](#) [00-8722-RDPP](#) [00-8728-WHPP](#) [00-8869-RDPP](#) [00-9051-RDPP](#) [00-9091-LRPP](#) [00-9291-RDPP](#) [0207100000](#) [0207400000](#) [01312](#) [0134220000](#) [60713816](#) [M15730061](#) [61161-90](#) [61278-0020](#) [6131-204-23149P](#) [6131-205-17149P](#) [6131-209-15149P](#) [6131-218-17149P](#) [6131-220-21149P](#) [6131-260-2358P](#) [6131-265-11149P](#) [CS1HCPU63](#)