

16 W non-isolated auxiliary power supply for outdoor air conditioner using CoolSET™ ICE5BR3995BZ-1

REF_5BR3995BZ-1_16W1

About this document

Scope and purpose

This document is a reference design for a 16 W auxiliary power supply for an invertized air conditioner unit with the latest CoolSET™ 5th Generation Fixed-Frequency Plus ICE5BR3995BZ-1 switching controller from Infineon. The power supply is designed with a universal input compatible with most geographic regions and three non-isolated outputs (12 V/900 mA, 15 V/150 mA, and 5 V/300 mA), where 15 V output and 5 V output are supported by a linear regulator from an 18 V source and 8 V source respectively.

Highlights of the auxiliary power supply for the invertized air conditioner unit are:

- Tightly regulated output voltages, high efficiency under light load, and low standby power
- Comprehensive CoolSET™ protection feature
- Auto-restart protection scheme to minimize interruption and enhance user-friendly experience

Intended audience

This document is intended for power supply design engineers who are designing auxiliary power supplies for outdoor air conditioner units that are efficient, reliable, and easy to design.

CoolSET™

Infineon's CoolSET™ AC-DC integrated power stages in fixed-frequency switching scheme offers increased robustness and outstanding performance. This family offers superior energy efficiency, comprehensive protective features, and reduced system costs and is ideally suited for auxiliary power supply applications in a wide variety of potential applications such as:

- [SMPS](#)
- [Home appliances](#)
- [Server](#)
- [Telecom](#)

16 W non-isolated auxiliary power supply for outdoor air conditioner using CoolSET™ ICE5BR3995BZ-1



REF_5BR3995BZ-1_16W1

Table of contents

Table of contents

About this document	1
Table of contents	2
1 Introduction	4
2 Reference board design	6
3 Power supply specifications	7
4 Schematic	8
5 Circuit description	9
5.1 EMI filtering and line rectification	9
5.2 Flyback converter power stage	9
5.3 Control of flyback converter through CoolSET™ 5 th Generation Fixed-Frequency Plus ICE5BR3995BZ-1	9
5.3.1 Current sensing	9
5.3.2 Feedback and compensation network	9
5.4 Unique features	10
5.4.1 Fast self-start-up and sustaining of V_{CC}	10
5.4.2 CCM, DCM operation with frequency reduction	10
5.4.3 Frequency jittering with modulated gate drive	11
5.4.4 System robustness and reliability through protection features	11
5.5 Clamper circuit	11
5.6 PCB design recommendations	11
6 PCB layout	13
6.1 Top side	13
6.2 Bottom side	13
7 Bill of materials	14
8 Transformer specification	16
9 Measurement data and graphs	17
9.1 Efficiency curve	19
9.2 Standby power	20
9.3 Line and load regulation	21
9.4 Maximum input power	21
9.5 Surge immunity (EN 61000-4-5)	22
9.6 Conducted emissions (EN 55022 Class B)	22
9.7 Thermal measurement	23
9.8 +18 V rail regulation (LDO input)	25
10 Waveforms and oscilloscope plots	26
10.1 Start-up at full load	26
10.2 Soft-start at full load	26
10.3 Drain and CS voltage at full load	27
10.4 Frequency jittering	27
10.5 Load-transient response	28
10.6 Output ripple voltage at full load	28
10.7 Output ripple voltage at ABM (minimum load)	29
10.8 Entering ABM	29
10.9 During ABM	30

16 W non-isolated auxiliary power supply for outdoor air conditioner using CoolSET™ ICE5BR3995BZ-1

REF_5BR3995BZ-1_16W1

Table of contents

10.10	Leaving ABM	30
10.11	V _{CC} OV/UV protection	31
10.12	Overload protection	31
11	Appendix A: WE transformer specification.....	32
	References.....	33
	Design support	34
	Revision history.....	35
	Disclaimer.....	36

16 W non-isolated auxiliary power supply for outdoor air conditioner using CoolSET™ ICE5BR3995BZ-1

REF_5BR3995BZ-1_16W1

Introduction

1 Introduction

With the growing household trend for smart devices, the new generation of home appliances including air conditioners are equipped with advanced features such as wireless control and monitoring capability, smart sensors, and touch screen display transforming a static product into an interactive and intelligent home appliance, capable of adapting to the smart-home theme. To support this trend, Infineon has introduced the latest CoolSET™ 5th Generation Fixed-Frequency Plus ICE5BR3995BZ-1 switching controller to address this need in an efficient and cost-effective manner.

An auxiliary SMPS is needed to power the various modules and sensors, which typically operate from a stable DC voltage source. The CoolSET™ switching controller (as shown in Figure 1) from Infineon forms the heart of the system, providing the necessary protection and AC-DC conversion from the mains to multiple regulated DC voltages to power the various blocks.

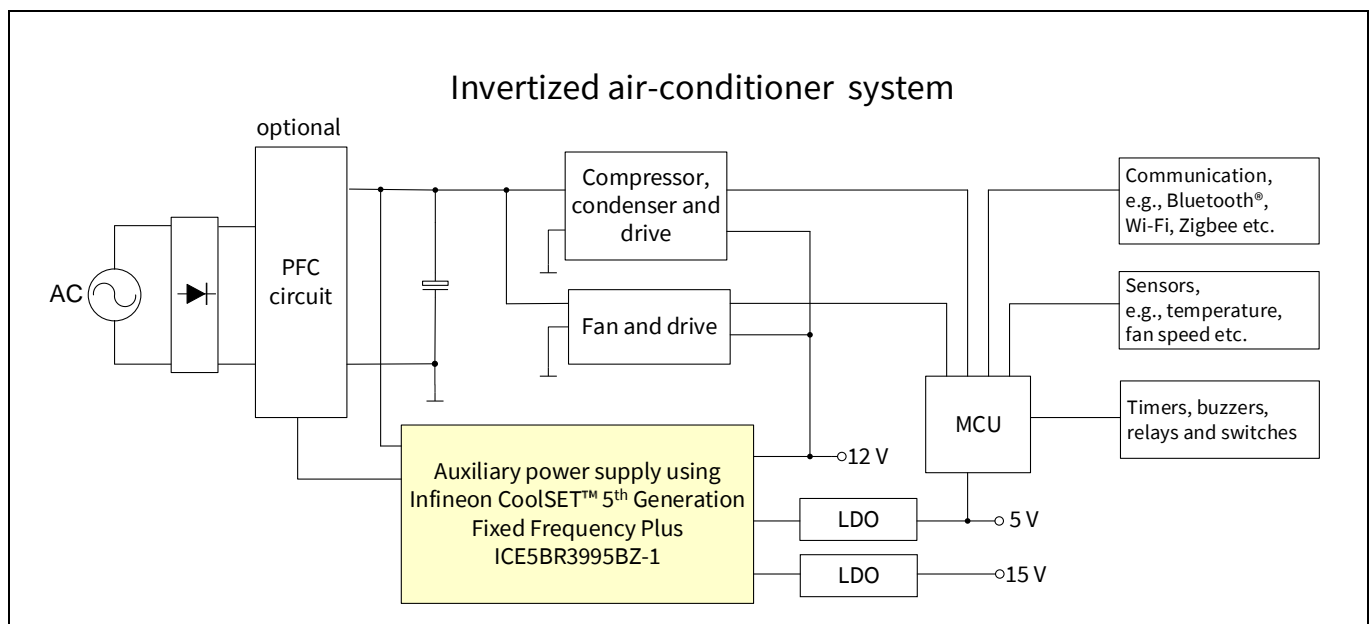

Figure 1 Simplified outdoor air-conditioner unit system block diagram example

Table 1 lists the system requirements for an auxiliary power supply for the invertized air-conditioner unit, and the corresponding Infineon solution is shown in the right column.

Table 1 System requirements and Infineon solutions

	System requirement for invertized air conditioner unit power supply	Infineon solution – ICE5BR3995BZ-1
1	High efficiency under light load and low standby power	New Fixed Frequency control and active burst mode (ABM)
2	Robust system and protection features	Comprehensive protection feature CoolSET™ in DIP-7 package
3	Auto-restart protection scheme to minimize interruption and enhance end-user experience	All protections are in auto restart

16 W non-isolated auxiliary power supply for outdoor air conditioner using CoolSET™ ICE5BR3995BZ-1

REF_5BR3995BZ-1_16W1

Introduction

1.1 High efficiency under light load and low standby power

During a typical air conditioner operation, the power requirement fluctuates according to various use cases. However, in most cases where room temperature is already stabilized, the indoor and outdoor air conditioner units will reside in an idle state, in which the loading toward the auxiliary power supply is low. It is crucial that the auxiliary power supply operates as efficiently as possible, because it will be in this particular state for most of the period. Under light-load conditions, losses incurred with the power switch are usually dominated by the switching operation. The choice of switching scheme and frequency plays a crucial role in ensuring high conversion efficiency.

In this reference design, the ICE5BR3995BZ-1 switching controller is primarily chosen because of its frequency reduction switching scheme. Compared with a traditional Fixed Frequency flyback, the CoolSET™ ICE5BR3995BZ-1 switching controller reduces its switching frequency from medium to light load, minimizing the switching losses. Therefore, an efficiency of more than 80 percent is achievable under 25 percent load conditions and nominal input voltages.

1.2 Simplified circuitry with good integration of power and protection features

To relieve the designer of the complexity of PCB layout and circuit design, CoolSET™ switching controller is a highly integrated device with both a controller and a high-voltage (HV) MOSFET integrated into a single and space-saving DIP-7 package. This helps the designer to reduce component count.

1.3 Auto-restart protection scheme to minimize interruption and enhance end-user experience

For an invertized air conditioner unit, it would be discomfoting to both the end user and the manufacturer if the system were to halt and latch after protection. Accessibility of the input AC plug may also be difficult; therefore, to minimize interruption, the CoolSET™ switching controller implements an auto-restart mode for all abnormal protections.

16 W non-isolated auxiliary power supply for outdoor air conditioner using CoolSET™ ICE5BR3995BZ-1

REF_5BR3995BZ-1_16W1

Reference board design

2 Reference board design

This document provides complete design details including specifications, schematics, bill of materials (BOM), PCB layout, and transformer design and construction information. Performance results pertaining to line/load regulation, efficiency, transient load, thermal conditions, conducted EMI scans, and so on are also included.

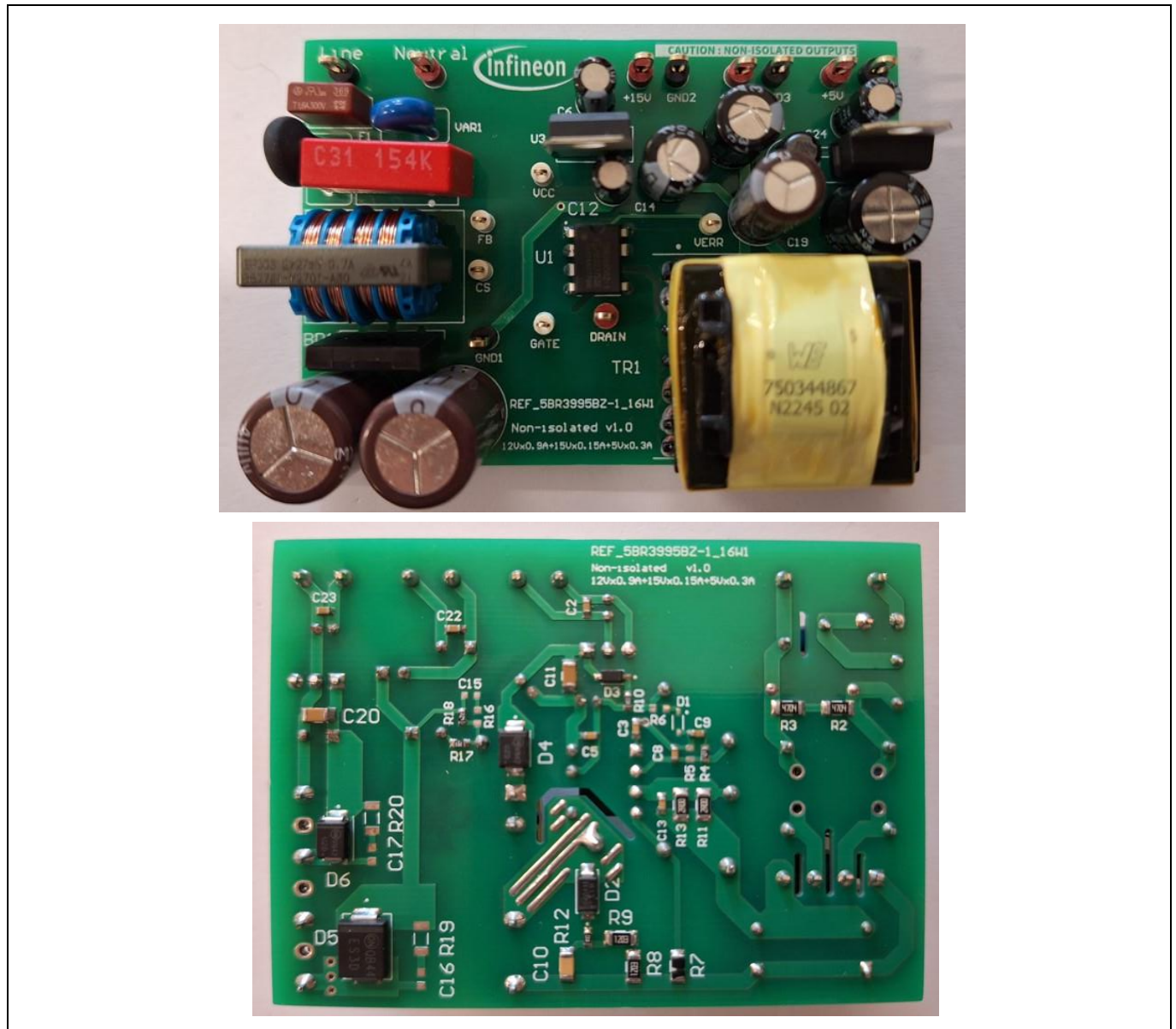

Figure 2 REF_5BR3995BZ-1_16W1

16 W non-isolated auxiliary power supply for outdoor air conditioner using CoolSET™ ICE5BR3995BZ-1



REF_5BR3995BZ-1_16W1

Power supply specifications

3 Power supply specifications

Table 2 shows the minimum acceptance performance of the design at 25°C ambient temperature. Actual performance is listed in the measurements section.

Table 2 Specifications of REF_5BR3995BZ-1_16W1

Description	Symbol	Min.	Typ.	Max.	Units	Comments
Input						
Voltage	V_{IN}	85	–	264	V AC	Two wires (no P.E.)
Frequency	f_{LINE}	47	50/60	64	Hz	
Output						
Output voltage 1	V_{OUT1}	–	12	–	V	±1 percent
Output current 1	I_{OUT1}	–	–	0.9	A	
Output voltage ripple 1	$V_{RIPPLE1}$	–	–	60	mV	
Output voltage 2	V_{OUT2}	–	15	–	V	±1 percent
Output current 2	I_{OUT2}	–	–	0.15	A	
Output voltage ripple 2	$V_{RIPPLE2}$	–	–	50	mV	
Output voltage 3	V_{OUT3}	–	5	–	V	±1 percent
Output current 3	I_{OUT3}	–	–	0.3	A	
Output voltage ripple 3	$V_{RIPPLE3}$	–	–	50	mV	
Output power	P_{OUT_Nom}	–	13.35	–	W	
Overcurrent protection (+12 V)	I_{OCP}	–	–	1.3	A	Full load on other outputs
Start-up time	t_{start_up}	–	–	250	ms	–
Environmental						
Conducted EMI	–	10			dB	Margin, CISPR 22 Class B
Surge immunity						
Differential mode	–	±2			kV	EN 61000-4-5
PCBA dimension	–	80 x 57 x 27			mm	L x W x H

16 W non-isolated auxiliary power supply for outdoor air conditioner using CoolSET™ ICE5BR3995BZ-1

REF_5BR3995BZ-1_16W1

Schematic

4 Schematic

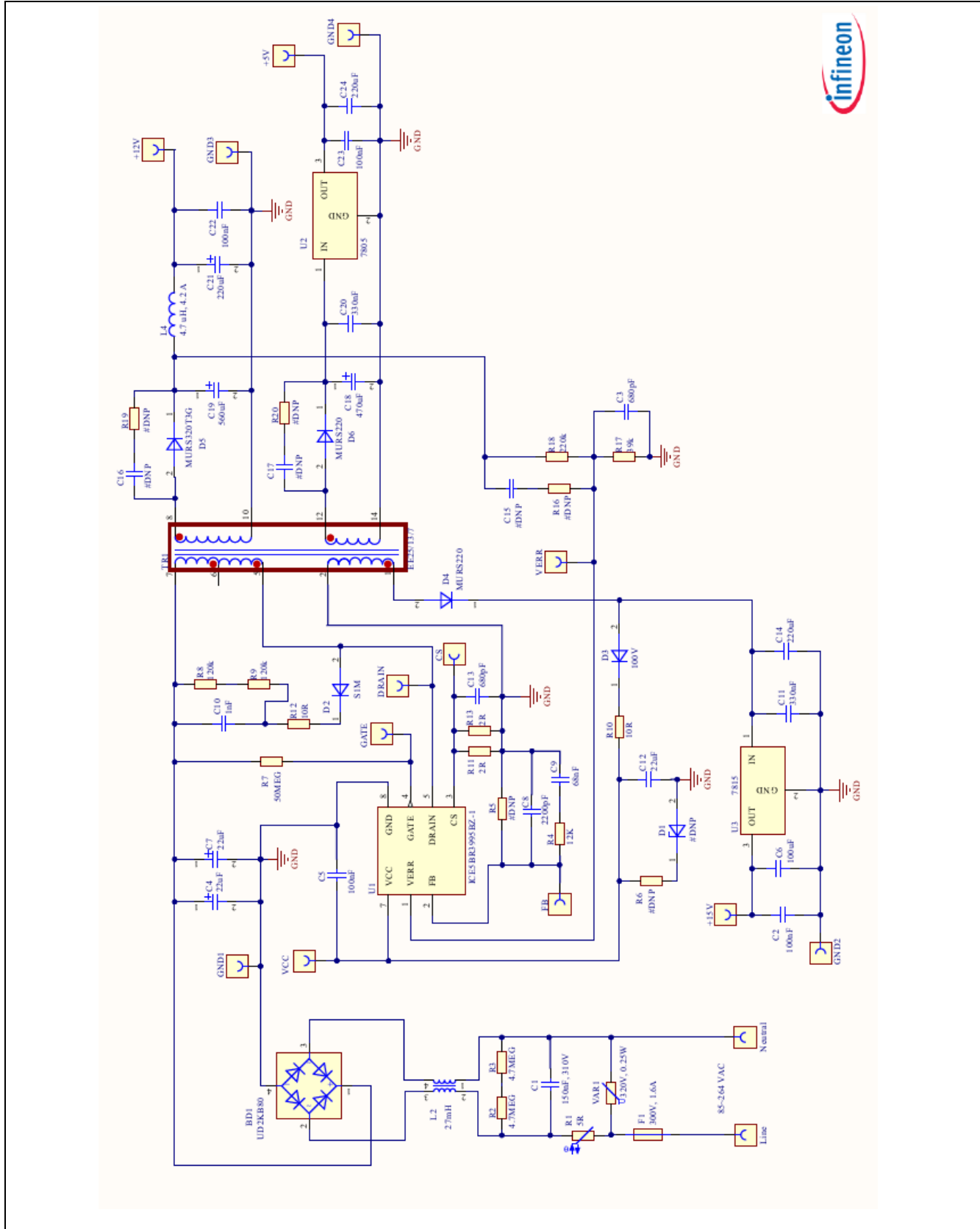

Figure 3 REF_5BR3995BZ-1_16W1

5 Circuit description

In this section, the design circuit for the SMPS unit will be briefly described by the different functional blocks. For details of the design procedure and component selection for the flyback circuitry, see the IC design guide [2] and calculation tool [3].

5.1 EMI filtering and line rectification

The input of the power supply unit is taken from the AC power grid, which is in the range of 85 V AC ~ 264 V AC. The fuse (F1) is directly connected to the input line to protect the system in case of excess current entering the system circuit due to any fault. Following is the varistor (VAR1), which is connected across the input to absorb excessive energy during line-surge transient. The X-capacitor (C1) and common-mode choke (CMC) (L2) reduce the EMI noise. R2 and R3 serve as the X-capacitor discharge resistor. The thermistor (R1) is in series with line to limit inrush current. The bridge rectifier (BR1) rectifies the AC input into DC voltage, filtered by the bulk capacitor (C4 and C7).

5.2 Flyback converter power stage

The flyback converter power stage consists of transformer (TR1), CoolSET™, secondary rectification diodes (D5 and D6), secondary output capacitors (C18 and C19), and output filter inductor (L4).

When the primary HV MOSFET turns on, energy is stored in the transformer. When it turns off, the stored energy is discharged to the output capacitors and into the output load.

Secondary winding is sandwiched between two layers of primary winding to reduce leakage inductance. This improves efficiency and reduces voltage spikes.

For the output rectification, lower forward voltage and ultra-fast recovery diodes can improve efficiency. Capacitor (C19) stores the energy needed during output load jumps. LC filter (L4/C21) reduces the high-frequency (HF) ripple voltage.

The +15 V output is from the 15 V low dropout (LDO) regulator (U3) with an input of +18 V. +5 V output is from the 5 V LDO regulator (U2) with an input of +8 V. As such, these outputs should not be affected by cross-regulation. However, its input should be maintained within the operating range of the LDO.

5.3 Control of flyback converter through CoolSET™ 5th Generation Fixed-Frequency Plus ICE5BR3995BZ-1

5.3.1 Current sensing

ICE5BR3995BZ-1 is a current mode switching controller. The primary peak current is controlled cycle-by-cycle through the current sense (CS) resistors (R11 and R13) in the CS pin (pin 3). Transformer saturation can be avoided through peak-current limitation (PCL); therefore, the system is more protected and reliable.

5.3.2 Feedback and compensation network

Resistor (R17 and R18) comprises a voltage divider, which is used to sense the V_{OUT} and directly feed back the output signal to the error amplifier pin (pin 1) of U1 as the output is non-isolated. A Type II compensation network (C8, C9, and R4) is connected between the FB pin (pin 2) and GND pin (pin 8) of the U1 to stabilize the system.

16 W non-isolated auxiliary power supply for outdoor air conditioner using CoolSET™ ICE5BR3995BZ-1

REF_5BR3995BZ-1_16W1

Circuit description

The FB pin of the ICE5BR3995BZ-1 switching controller is a multifunction pin, which is used to select the entry burst power level (there are three levels available) through the resistor at the FB pin (R5) and also the burst-on/burst-off sense input during ABM.

5.4 Unique features

5.4.1 Fast self-start-up and sustaining of V_{CC}

The IC uses a cascode structure to fast-charge the V_{CC} capacitor. Pull-up resistors (R7) connected to the GATE pin (pin 4) are used to initiate the start-up phase. At first, $I_{VCC_Charge1}$ is used to charge the V_{CC} capacitor from 0 V to V_{CC_SCP} . This is a protection, which reduces the power dissipation of the power MOSFET during V_{CC} short-to-GND condition. Thereafter, a much higher charging current of $I_{VCC_Charge2}$ will charge the V_{CC} capacitor until the V_{CC_ON} is reached.

After start-up, the IC V_{CC} supply is usually sustained by the auxiliary winding of the transformer, which needs to support the V_{CC} to be above the undervoltage lockout (UVLO) voltage (10 V typ.). In this reference board, the V_{CC} supply is tapped from the +18 V winding.

5.4.2 CCM, DCM operation with frequency reduction

ICE5BR3995BZ-1 switching controller can be operated in either discontinuous conduction mode (DCM) or continuous conduction mode (CCM) with frequency-reduction features. This reference board is designed to operate in DCM at operating input voltage and load conditions. When the system is operating at a high output load, the controller will switch at 65 kHz. In order to achieve a better efficiency between light load and medium load, frequency reduction is implemented as a function of V_{FB} , as shown in Figure 4. The switching frequency will not reduce further once the minimum switching frequency of 28 kHz is reached.

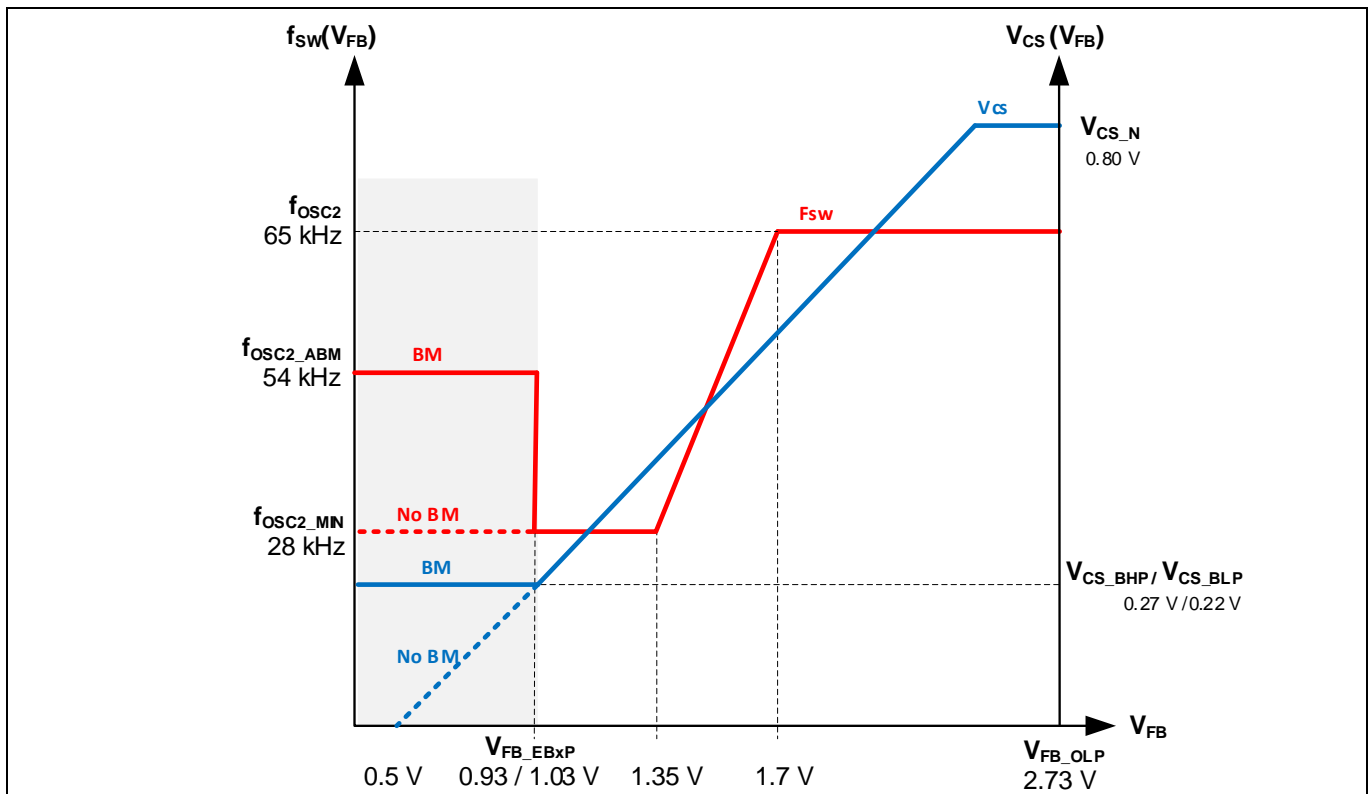

Figure 4 Frequency reduction curve

16 W non-isolated auxiliary power supply for outdoor air conditioner using CoolSET™ ICE5BR3995BZ-1

REF_5BR3995BZ-1_16W1

Circuit description

5.4.3 Frequency jittering with modulated gate drive

ICE5BR3995BZ-1 switching controller has a frequency jittering feature with a modulated gate drive to reduce the EMI noise. The jitter frequency is internally set at 65 kHz (± 4 kHz), and the jitter period is 4 ms.

5.4.4 System robustness and reliability through protection features

Protection is one of the major factors in determining whether the system is safe and robust – therefore, sufficient protection is necessary. ICE5BR3995BZ-1 switching controller provides comprehensive protection to ensure that the system is operating safely. This includes V_{CC} overvoltage (OV) and undervoltage (UV), overload, overtemperature, and V_{CC} short-to-GND. When those faults are detected, the system will enter into protection mode. Once the fault is removed, the system resumes normal operation. The following table lists the protections and the failure conditions.

Table 3 Protection functions of ICE5BR3995BZ-1 switching controller

Protection function	Failure condition	Protection mode
V_{CC} OV	$V_{VCC} > V_{VCC_OVP}$	Extended cycle skip auto-restart
V_{CC} UV	$V_{VCC} < V_{VCC_off}$	Auto-restart
Overload	$V_{FB} > V_{FB_OLP}$ and lasts for $t_{FB_OLP_B}$	Extended cycle skip auto-restart
Overtemperature	$T_J > 140^\circ\text{C}$ (40°C hysteresis)	Non-switch auto-restart
V_{CC} short-to-GND ($V_{VCC} = 0$ V, $R_{startup} = 50$ M Ω , $V_{DRAIN} = 90$ V)	$V_{VCC} < V_{VCC_SCP}$, $I_{VCC_Charge1} \approx -0.2$ mA	Cannot start up

5.5 Clamper circuit

A clamper network consisting of a diode (D2), a capacitor (C10), and resistors (R8, R9, R12) are used to reduce the switching voltage spikes across the DRAIN of the integrated HV MOSFET of the CoolSET™, which are generated by the leakage inductance of the transformer (TR1). This is a dissipative circuit; therefore, R8, R9, and C10 need to be fine-tuned depending on the voltage derating factor and efficiency requirement.

5.6 PCB design recommendations

Following are the recommendations for a good PCB design layout.

- The switching power loop needs to be as small as possible (see [Figure 5](#)). There are three power loops in the reference design; one on the HV side and two on the output side. The HV loop starts from the bulk capacitor (C7) positive terminal, primary transformer winding, CoolSET™ (CS) resistors and back to the (C7) negative terminal. The first output side loop (+12 V output) starts at the transformer winding (pin 8), output diode (D5), output capacitor C19 and back to pin 10 of TR1. The second output loop (+8 V output) starts at the transformer winding (pin 12 of TR1), output diode (D6), output capacitor (C18) and back to pin 14 of T1. The third output loop (18 V output) starts at the transformer winding (pin 2 of TR1), output diode (D4), output capacitor (C14) and back to pin 1 of T1.

16 W non-isolated auxiliary power supply for outdoor air conditioner using CoolSET™ ICE5BR3995BZ-1

REF_5BR3995BZ-1_16W1

Circuit description

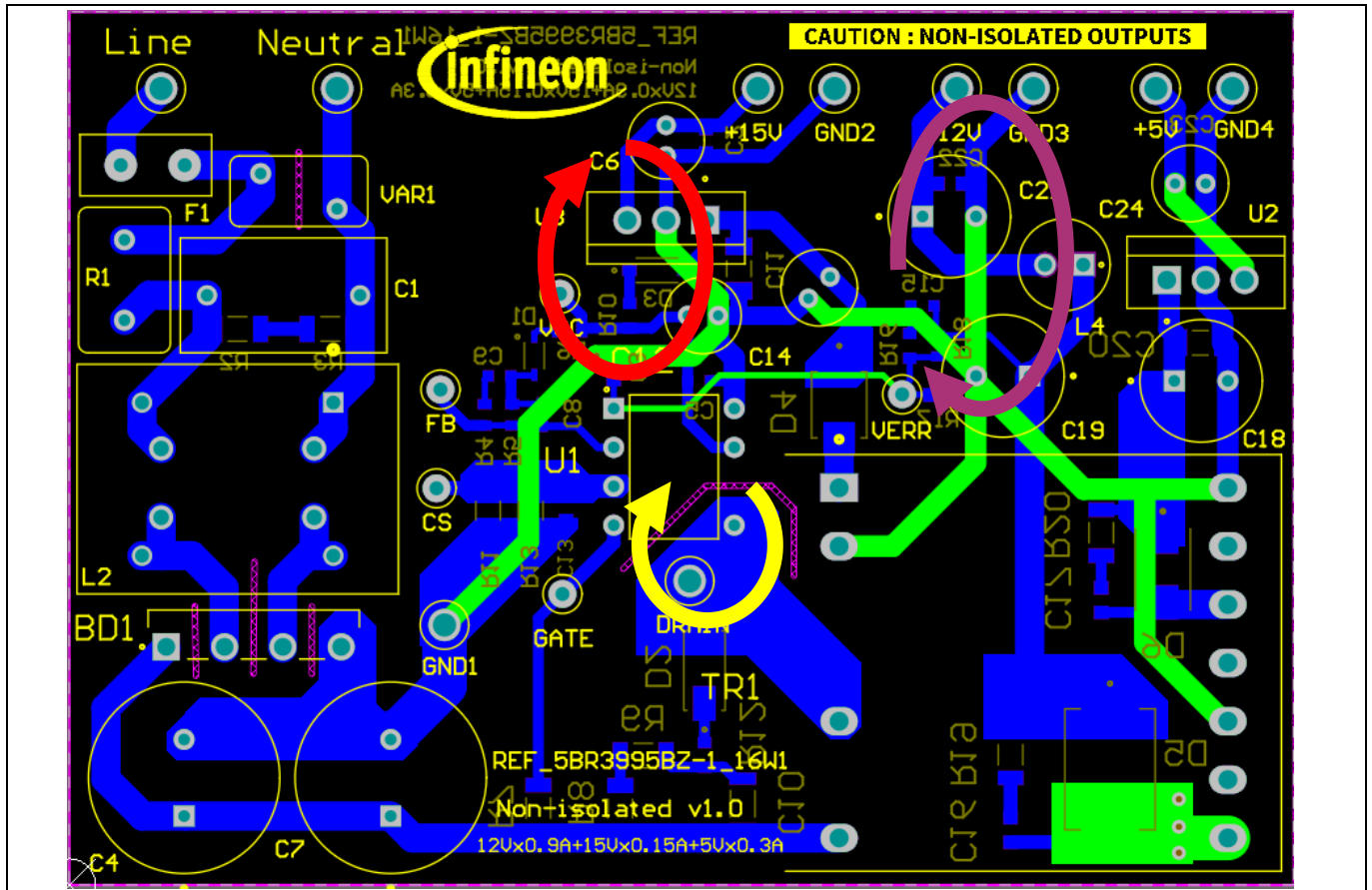

Figure 5 PCB layout tips

- Use the star-ground connection to reduce high frequency (HF) noise coupling that can affect the functional operation. The ground of the small-signal components should connect directly to the IC ground.
- Separating the HV components and low voltage (LV) components, e.g., a clamer circuit, at the top part of the PCB and the other LV components at the lower part of the PCB can reduce the spark-over chance of the high energy surge during a lightning surge test.
- Make the PCB copper pour on the DRAIN pin of the MOSFET act as a heatsink.

16 W non-isolated auxiliary power supply for outdoor air conditioner using CoolSET™ ICE5BR3995BZ-1

REF_5BR3995BZ-1_16W1

PCB layout

6 PCB layout

6.1 Top side

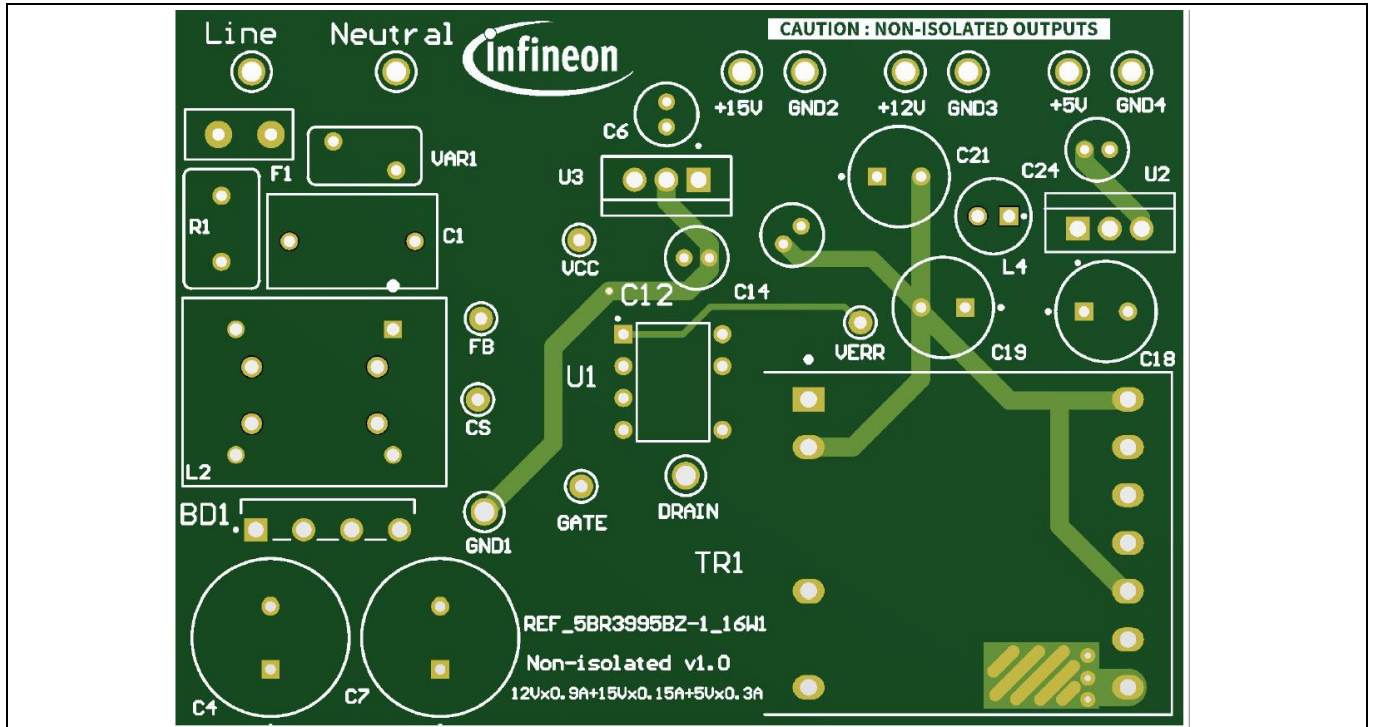

Figure 6 Top-side component legend

6.2 Bottom side

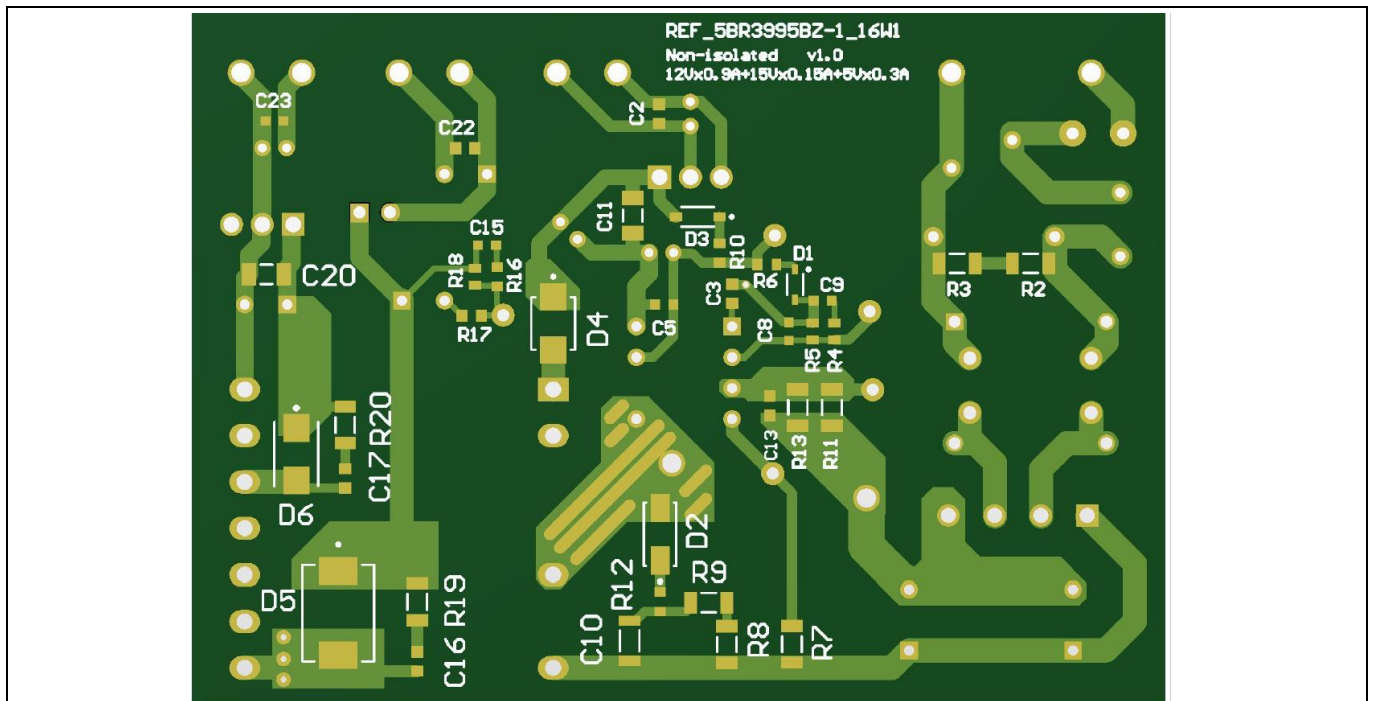

Figure 7 Bottom-side component legend

16 W non-isolated auxiliary power supply for outdoor air conditioner using CoolSET™ ICE5BR3995BZ-1



REF_5BR3995BZ-1_16W1

Bill of materials

7 Bill of materials

Table 4 BOM

No.	Designator	Description	Part number	Manufacturer	Quantity
1	BR1	Bridge rectifiers 2 A 800 V	UD2KB80-7000	Shindengen	1
2	C1	Film capacitors, 150 nF, 310 V AC	890334023025	Würth Elektronik	1
3	C2, C5, C22, C23	MLCC – SMD/SMT 50 V 0.1 μ F X7R 0603 10%	–	–	4
4	C4, C7	Aluminum capacitor 22 μ F 20% 400 V radial	EKXG401ELL220MK20S	United Chemi-Con	2
5	C6, C24	Aluminum capacitor 100 μ F 20% 25 V radial	25PX100MEFC5X11	Rubycon	2
6	C8	MLCC – SMD/SMT 0603 50 V 2200 pF 10%	–	–	1
7	C10	MLCC – SMD/SMT 500 V 1000 pF X7R 1206 10%	–	–	1
8	C9	MLCC – SMD/SMT 0603 50 V 68 nF 10%	–	–	1
9	C3, C13	MLCC – SMD/SMT 0603 50 V 680 pF 10%	–	–	2
10	C11, C20	MLCC – SMD/SMT 1206 50V 330nF 10%	–	–	2
11	C12	Aluminum capacitor 22 μ F 20% 35V radial	UVR1V220MDD	Nichicon	1
12	C14, C21	Aluminum capacitor 220 μ F 20% 35V radial	35ZLH220MEFCT78X11.5	Rubycon	2
13	C18	Aluminum capacitor 470 μ F 20% 16V radial	UHE1C471MPD	Nichicon	1
14	C19	Aluminum capacitor 560 μ F 20% 25V radial	25ZLJ560M8X20	Rubycon	1
15	D2	General-purpose diode 1 kV 1 A SMA	S1M	–	1
16	D3	General-purpose diode 100 V 150 mA SOD-123	BAV16W-7-F	Diodes Inc.	1
17	D4, D6	General-purpose diode 200 V 2 A SMB	MURS220T3G	ON Semiconductor	2
18	D5	General-purpose diode 200 V 3 A SMC	MURS320T3G	ON Semiconductor	1
19	F1	Time-lag fuse, 300 V, 1.6 A	36911600000	Littelfuse	1
20	L2	CMC 27 mH 700 mA 2LN TH	B82731M2701A030	TDK	1

16 W non-isolated auxiliary power supply for outdoor air conditioner using CoolSET™ ICE5BR3995BZ-1



REF_5BR3995BZ-1_16W1

Bill of materials

No.	Designator	Description	Part number	Manufacturer	Quantity
21	L4	Inductor WE-TI, size 5075, 4.7 μ H, 4.2 A	7447462047	Würth Elektronik	1
22	R1	ICL 5 Ω 20% 4.2 A 9.5 mm	B57235S0509M000	TDK Corporation	1
23	R2, R3	SMD resistor 4.7 m Ω 1% 1/4 W 1206	-	-	2
24	R4	SMD resistor 12 k Ω 1% 1/10 W 0603	-	-	1
25	R7	SMD resistor 50 m Ω 1% 300 mW 1206	CRHA1206AF50M0FKF	Vishay	1
26	R8, R9	SMD resistor 120 k Ω 1% 1/4 W 1206	-	-	2
27	R10, R12	SMD resistor 10 Ω 1% 1/10 W 0603	-	-	2
28	R11, R13	SMD resistor 2.0 Ω 1% 1/4 W 1206	-	-	2
29	R17	Resistor 39 k Ω 1% 1/10 W 0603	-	-	1
30	R18	Resistor 220 k Ω 1% 1/10 W 0603	-	-	1
31	TR1	EE25/13/7	750344867	Würth Elektronik	1
32	U1	Fixed Frequency 950 V CoolSET™	ICE5BR3995BZ-1	Infineon	1
33	U2	IC linear regulator 5 V 1.5 A TO-220AB	L7805ABV	STMicroelectronics	1
34	U3	IC linear regulator 15 V 1.5 A TO-220AB	L7815ABV	STMicroelectronics	1
35	VAR1	S07K320E2 320 V AC 10%	B72207S2321K101	Epcos	1
36	+5 V, +12 V, +15 V, DRAIN, neutral	Test point THT, red	5010	Keystone	5
37	CS, FB, GATE, VERR, V _{CC}	Test point THT, white	5002	Keystone	5
38	GND1, GND2, GND3, GND4, line	Test point THT, black	5011	Keystone	5

16 W non-isolated auxiliary power supply for outdoor air conditioner using CoolSET™ ICE5BR3995BZ-1

REF_5BR3995BZ-1_16W1

Transformer specification

8 Transformer specification

(See Appendix A for transformer design and Appendix B for WE transformer specification.)

Core name and material: EE25/13/7, TP4A (TDG)

Würth Elektronik bobbin: 070-6725 (14-pin, THT, horizontal version)

Primary inductance: $L_p = 820 \mu\text{H}$ (± 10 percent), measured between pin 5 and pin 7

Manufacturer and part number: Würth Elektronik (750344867) Rev.01

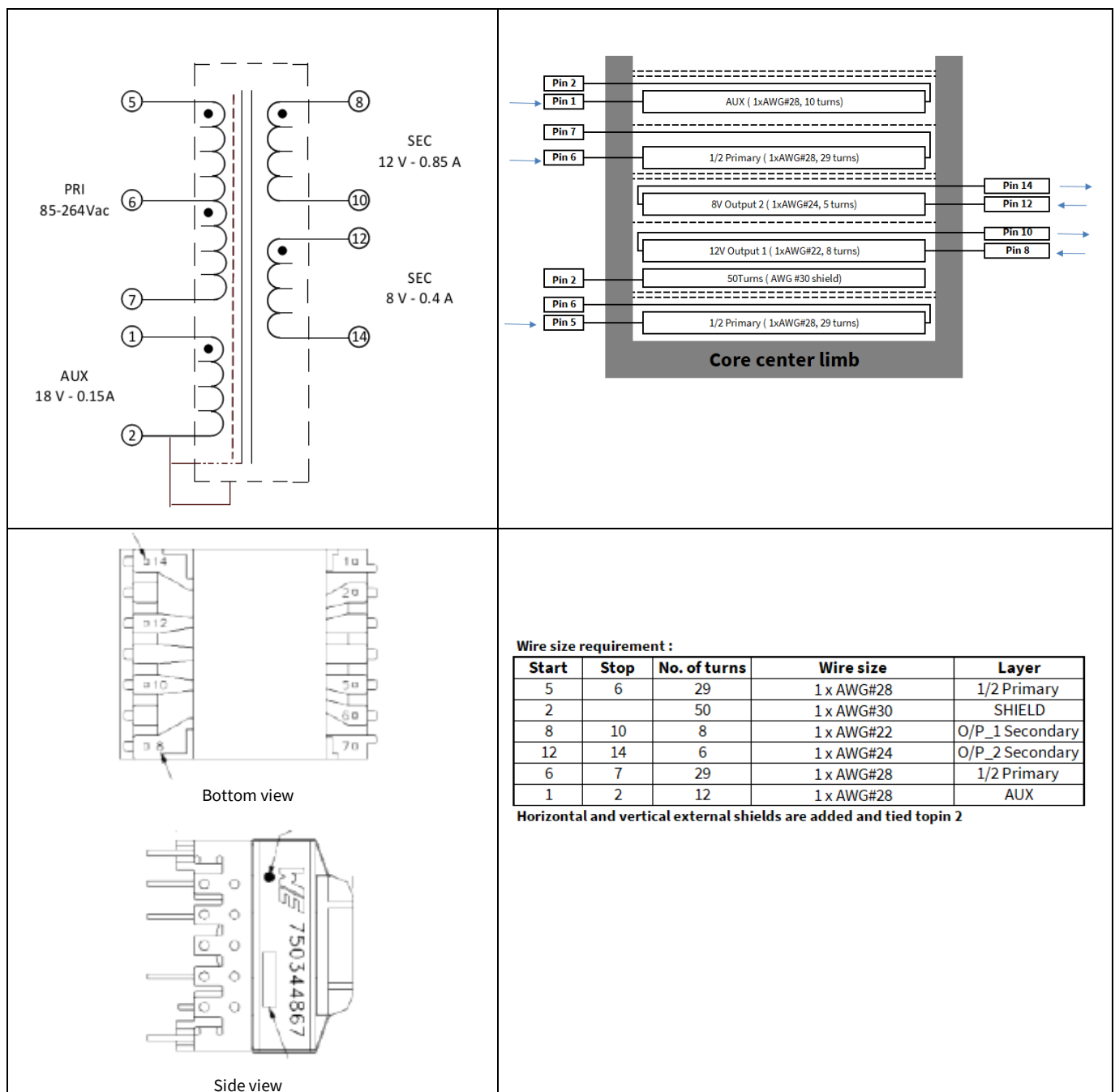

Figure 8 Transformer structure

16 W non-isolated auxiliary power supply for outdoor air conditioner using CoolSET™ ICE5BR3995BZ-1



REF_5BR3995BZ-1_16W1

Measurement data and graphs

9 Measurement data and graphs

Table 5 Electrical measurements

Input (V AC/Hz)	P _{IN} (W)	V _{O1} (V)	I _{O1} (A)	V _{O2} (V)	I _{O2} (A)	V _{O3} (V)	I _{O3} (A)	P _{OUT} (W)	Efficiency (%)	Average efficiency (%)	OLP P _{IN} (W)	OLP I _{O1} (A)
85 V AC/ 60 Hz	0.80	11.968	0.040	15.230	0.005	4.99	0.005	0.580	/	/	21.37	1.02
	4.95	11.984	0.224	15.212	0.040	4.98	0.075	3.667	74.07	74.39		
	9.66	11.968	0.444	15.195	0.080	4.97	0.148	7.265	75.21			
	14.82	11.968	0.680	15.187	0.119	4.96	0.223	11.052	74.58			
	19.61	11.968	0.895	15.185	0.149	4.96	0.298	14.452	73.70			
115 V AC/ 60 Hz	0.81	11.968	0.040	15.250	0.005	4.99	0.005	0.580	/	/	20.92	1.02
	4.92	11.968	0.224	15.215	0.040	4.98	0.075	3.663	74.46	75.42		
	9.55	11.968	0.444	15.205	0.080	4.97	0.148	7.266	76.08			
	14.56	11.953	0.680	15.205	0.119	4.96	0.223	11.044	75.85			
	19.18	11.953	0.895	15.215	0.149	4.96	0.298	14.443	75.30			
230 V AC/ 50 Hz	0.83	11.968	0.040	15.207	0.005	4.99	0.005	0.580	/	/	20.53	1.07
	5.00	11.968	0.224	15.192	0.040	4.98	0.075	3.662	73.25	75.53		
	9.56	11.968	0.444	15.187	0.080	4.97	0.148	7.264	75.99			
	14.51	11.968	0.680	15.177	0.119	4.96	0.223	11.051	76.16			
	18.82	11.953	0.895	15.212	0.149	4.96	0.298	14.443	76.74			
264 V AC/ 50 Hz	0.85	11.968	0.040	15.215	0.005	4.99	0.005	0.580	/	/	20.77	1.10
	5.05	11.968	0.224	15.192	0.040	4.98	0.075	3.662	72.52	75.01		
	9.70	11.968	0.444	15.187	0.080	4.97	0.148	7.264	74.89			
	14.53	11.953	0.680	15.177	0.119	4.96	0.223	11.041	75.99			
	18.85	11.953	0.895	15.232	0.149	4.96	0.298	14.446	76.63			

- **Minimum load condition:** 12 V/40 mA, 5 V/5 mA, 15 V/5 mA
- **25 percent load condition:** 12 V/0.23 A, 5 V/0.08 A, 15 V/0.04 A
- **50 percent load condition:** 12 V/0.45 A, 5 V/0.15 A, 15 V/0.08 A
- **75 percent load condition:** 12 V/0.68 A, 5 V/0.23 A, 15 V/0.12 A
- **100 percent load condition:** 12 V/0.9 A, 5 V/0.3 A, 15 V/0.15 A

16 W non-isolated auxiliary power supply for outdoor air conditioner using CoolSET™ ICE5BR3995BZ-1



REF_5BR3995BZ-1_16W1

Measurement data and graphs

Table 6 Efficiency and standby performance with single-output configuration (modified from original board for illustration purposes only)

Input (V AC/Hz)	P _{IN} (W)	V _{o1} (V)	I _{o1} (A)	P _{OUT} (W)	Efficiency (%)	Average efficiency (%)
85 V AC/60 Hz	0.011	11.984	0.000	0.000		
	1.368	11.875	0.093	1.104	80.73	
	3.070	11.875	0.216	2.565	83.55	82.89
	6.054	11.859	0.425	5.040	83.25	
	9.048	11.859	0.634	7.519	83.10	
	12.288	11.859	0.846	10.033	81.65	
115 V AC/60 Hz	0.014	11.984	0.000	0.000		
	1.368	11.875	0.093	1.104	80.73	
	3.053	11.875	0.216	2.565	84.02	83.70
	6.010	11.859	0.425	5.040	83.86	
	8.985	11.859	0.634	7.519	83.68	
	12.050	11.859	0.846	10.033	83.26	
230 V AC/50 Hz	0.021	11.984	0.000	0.000		
	1.463	11.875	0.093	1.104	75.49	
	3.124	11.875	0.216	2.565	82.11	83.46
	6.020	11.859	0.425	5.040	83.72	
	8.944	11.859	0.634	7.519	84.06	
	11.953	11.859	0.846	10.033	83.93	
264 V AC/50 Hz	0.029	11.984	0.000	0.000		
	1.501	11.875	0.093	1.104	73.58	
	3.164	11.875	0.216	2.565	81.07	82.85
	6.058	11.859	0.425	5.040	83.20	
	9.010	11.859	0.634	7.519	83.45	
	11.990	11.859	0.846	10.033	83.68	

Note: Single-output (+12 V) configuration efficiency measurement was done by removing two LDO output circuits and connecting +12 V output directly to the V_{CC} circuit; the actual board comes with LDO circuits. The overall circuit is not optimized for single-output configuration; the above efficiency data is for illustration only.

16 W non-isolated auxiliary power supply for outdoor air conditioner using CoolSET™ ICE5BR3995BZ-1

REF_5BR3995BZ-1_16W1

Measurement data and graphs

9.1 Efficiency curve

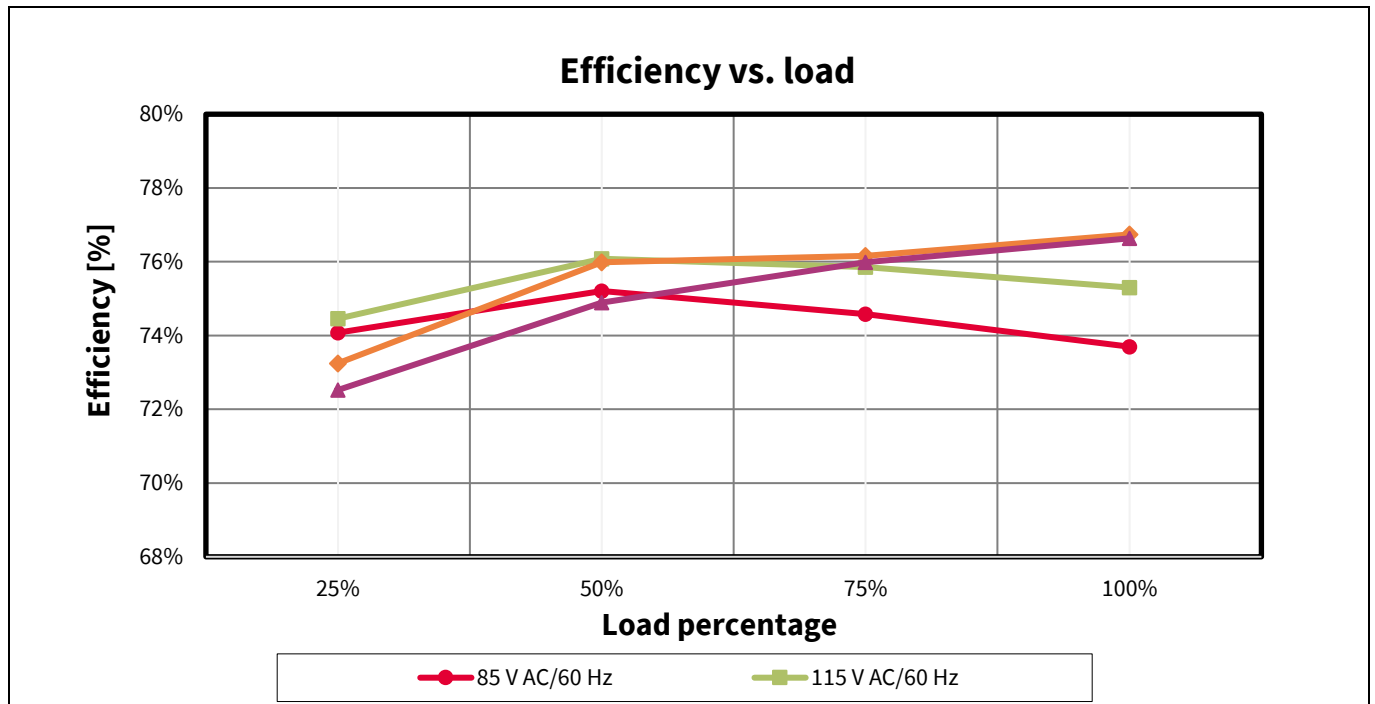

Figure 9 Efficiency vs. output load

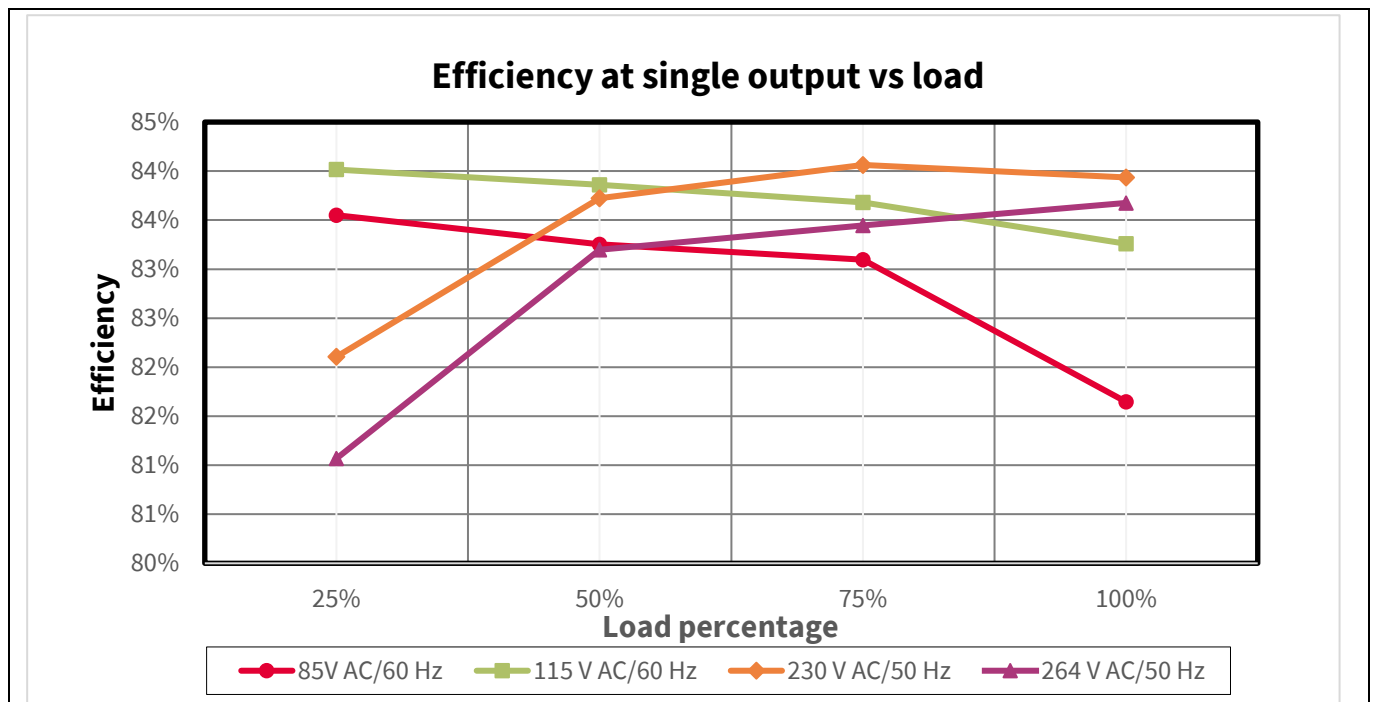

Figure 10 Efficiency at single output vs. output load

16 W non-isolated auxiliary power supply for outdoor air conditioner using CoolSET™ ICE5BR3995BZ-1

REF_5BR3995BZ-1_16W1

Measurement data and graphs

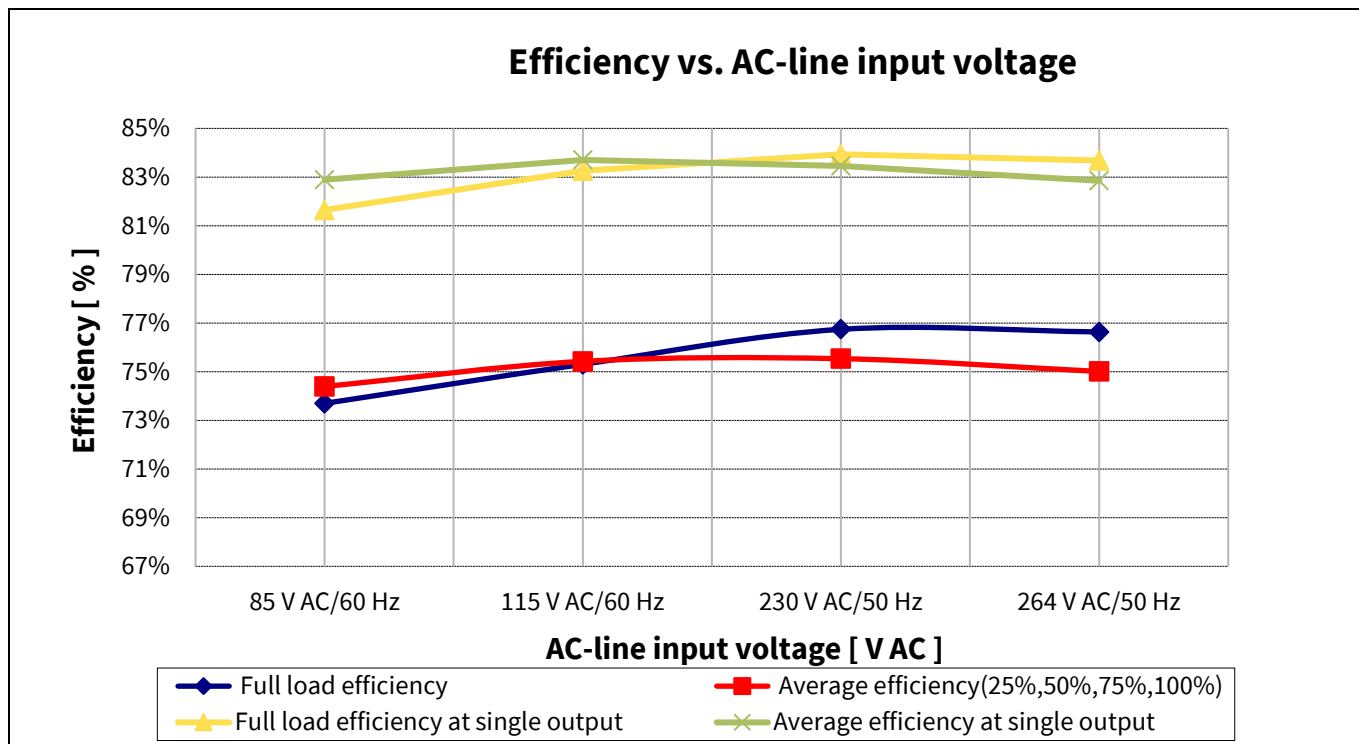

Figure 11 Efficiency vs. AC-line input voltage

9.2 Standby power

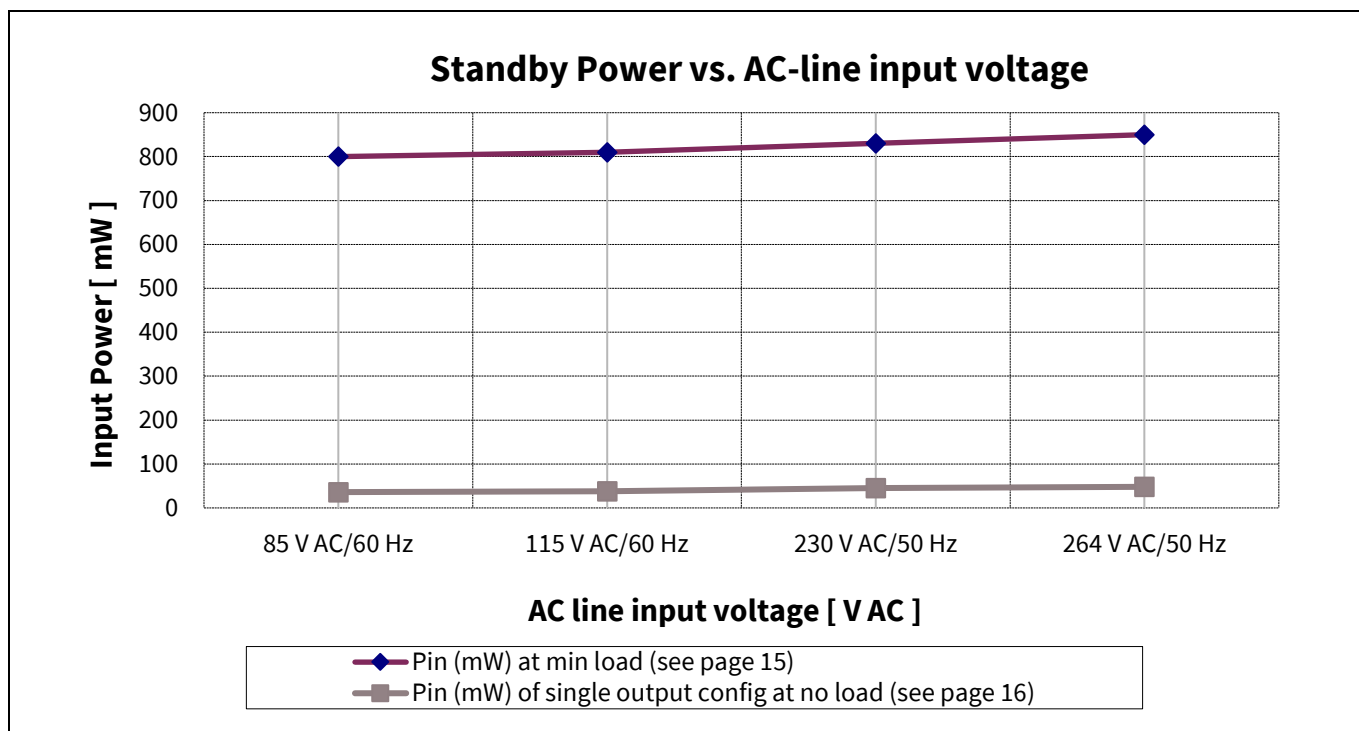

Figure 12 Standby power at minimum load vs. AC-line input voltage

16 W non-isolated auxiliary power supply for outdoor air conditioner using CoolSET™ ICE5BR3995BZ-1

REF_5BR3995BZ-1_16W1

Measurement data and graphs

9.3 Line and load regulation

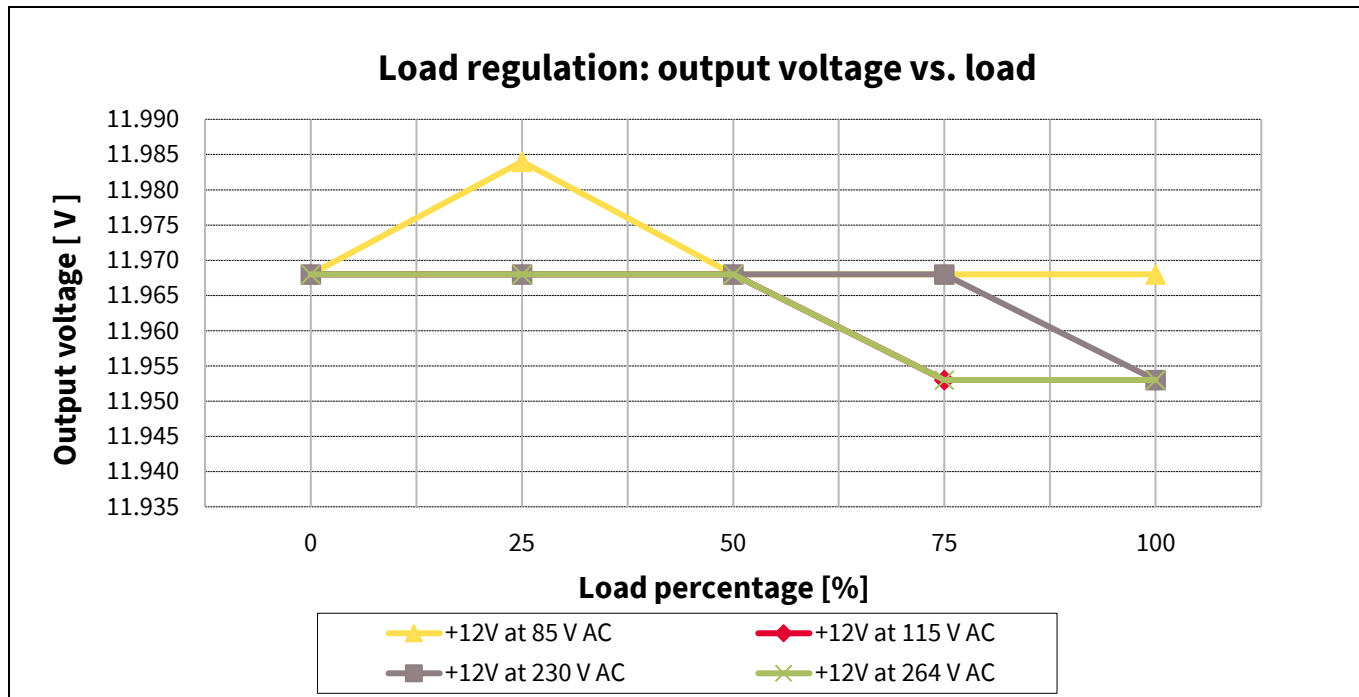

Figure 13 Output regulation vs. load at different AC-line input voltages

9.4 Maximum input power

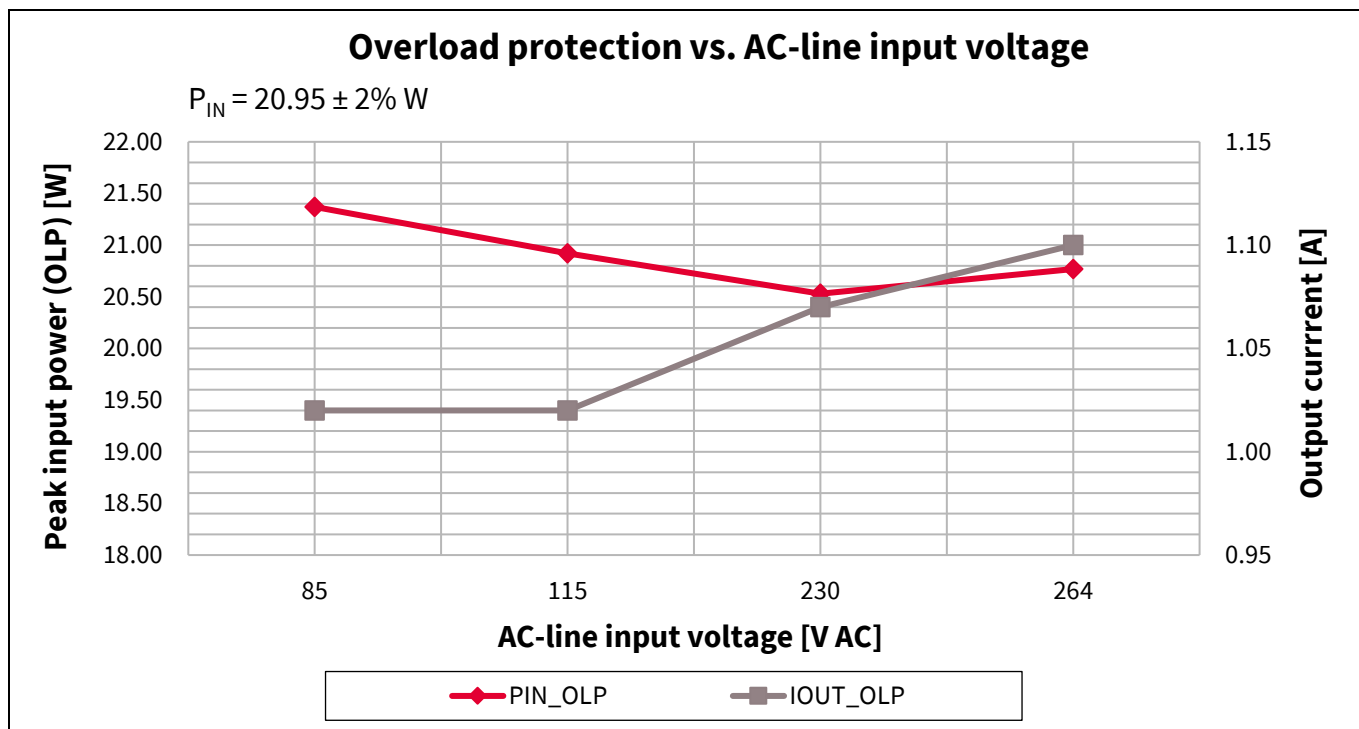

Figure 14 Maximum input power and output current (before overload protection) vs. AC-line input voltage

16 W non-isolated auxiliary power supply for outdoor air conditioner using CoolSET™ ICE5BR3995BZ-1

REF_5BR3995BZ-1_16W1

Measurement data and graphs

9.5 Surge immunity (EN 61000-4-5)

The reference board was subjected to a surge immunity test (± 2 kV DM) according to EN 61000-4-5. It was tested at full load (resistive load). A test failure was defined as non-recoverable.

Table 7 System surge immunity test result

Description	Test	Level	Number of strikes				Test result
			0°	90°	180°	270°	
115/230 V AC	DM	± 2 kV	3	3	3	3	Pass

9.6 Conducted emissions (EN 55022 Class B)

The conducted EMI was measured by Schaffner (SMR4503) and followed the test standard of EN 55022 (CISPR 22) Class B. The reference board was tested at full load (resistive load) at input voltage of 115 V AC and 230 V AC. It passed with more than 10 dB margin.

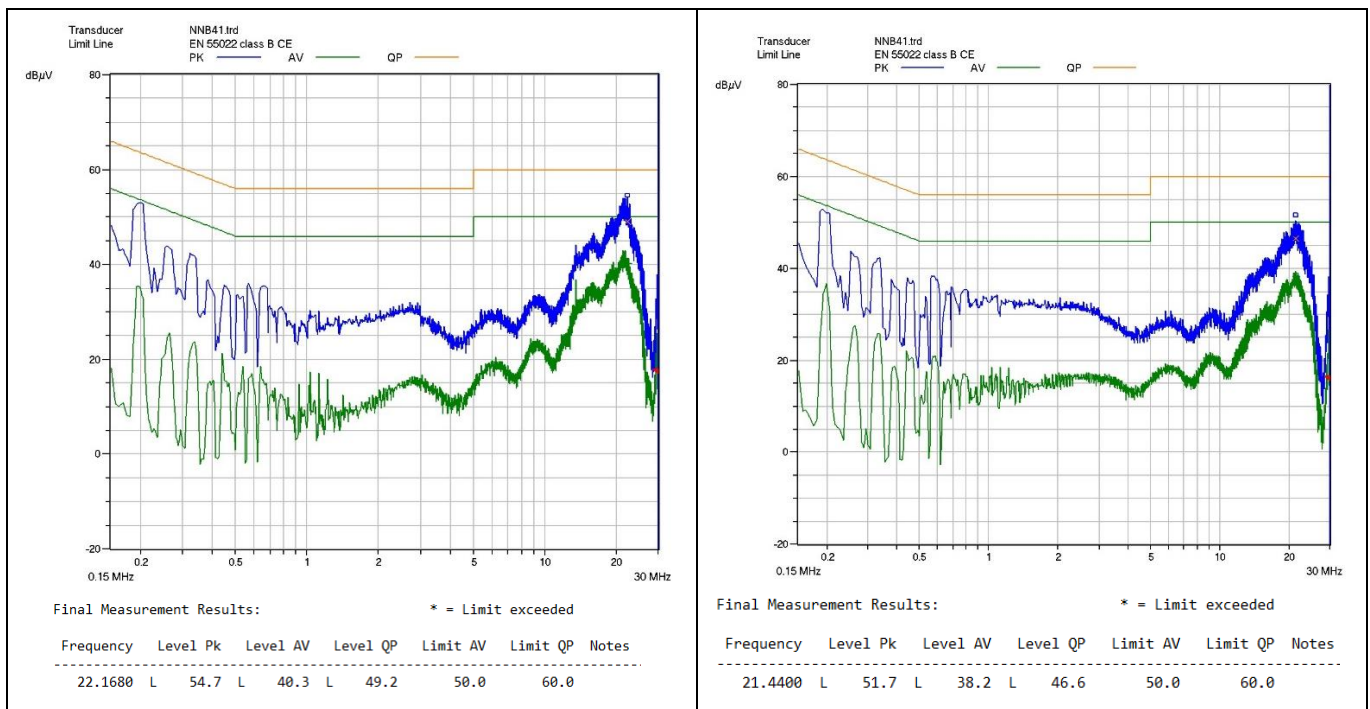

Figure 15 Conducted emissions at 115 V AC and full load on line (left) and neutral (right)

16 W non-isolated auxiliary power supply for outdoor air conditioner using CoolSET™ ICE5BR3995BZ-1

REF_5BR3995BZ-1_16W1

Measurement data and graphs

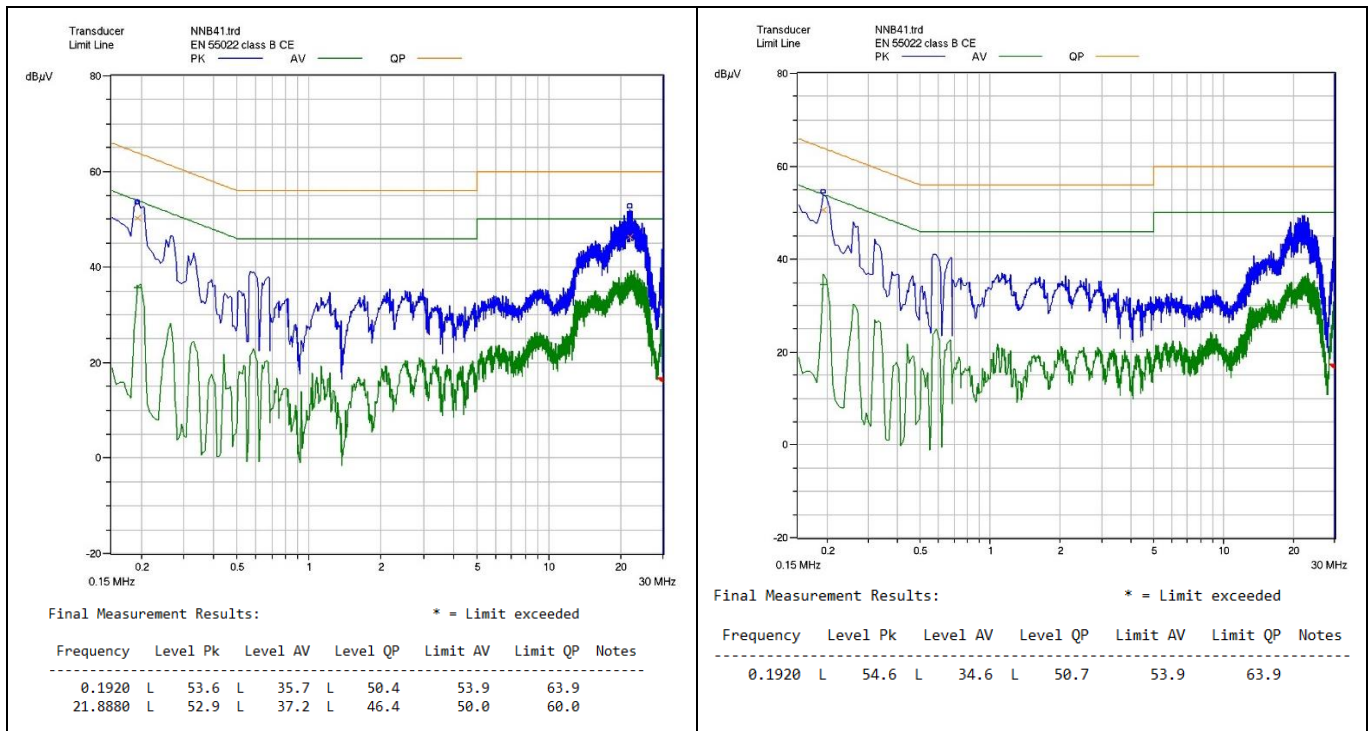

Figure 16 Conducted emissions at 220 V AC and full load on line (left) and neutral (right)

9.7 Thermal measurement

Thermal measurement was done using an infrared thermography camera (FLIR-T62101) at an ambient temperature of 25°C taken after one hour running at full load. The temperature of the components was taken in an open-frame set-up.

Table 8 Thermal measurement of components (open-frame)

No.	Component	Temperature at 85 V AC (°C)	Temperature at 264 V AC (°C)
1	BR1	50.2	38.2
2	U1	73.3	66.4
3	TR1	55.2	57.7
4	D5	71.3	71.4
5	D6	85.5	84
6	D4	59.5	60.1

16 W non-isolated auxiliary power supply for outdoor air conditioner using CoolSET™ ICE5BR3995BZ-1

REF_5BR3995BZ-1_16W1

Measurement data and graphs

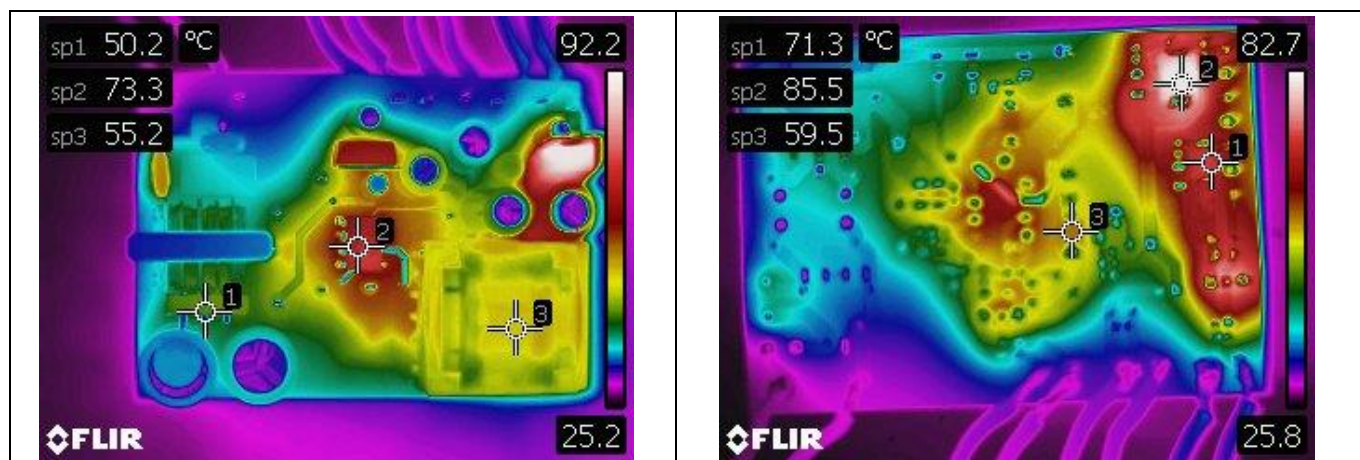

Figure 17 Top-layer (left) and bottom-layer (right) thermal image at 85 V AC input voltage

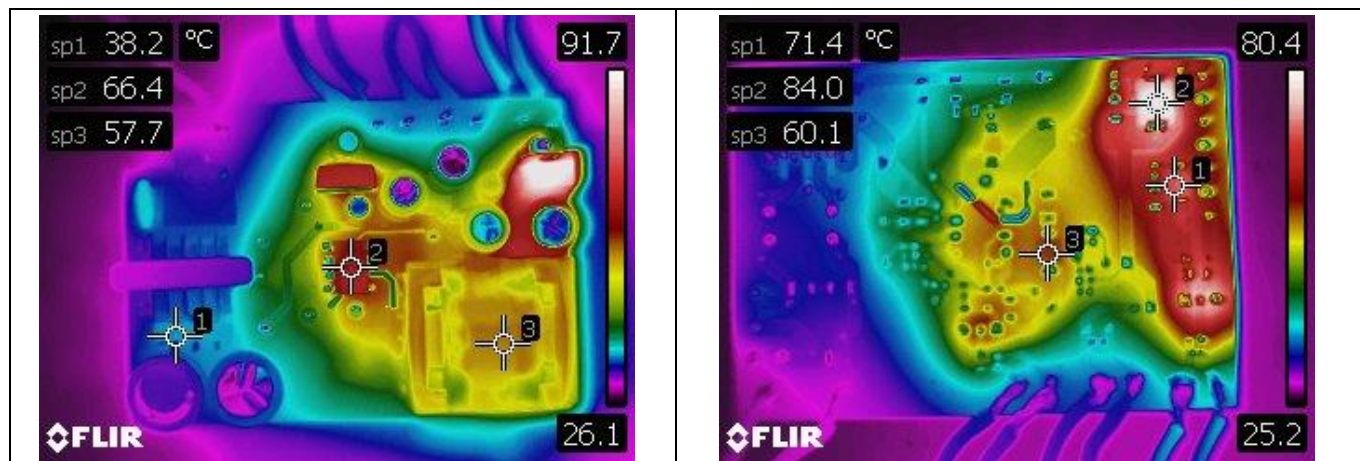

Figure 18 Top-layer (left) and bottom-layer (right) thermal image at 264 V AC input voltage

16 W non-isolated auxiliary power supply for outdoor air conditioner using CoolSET™ ICE5BR3995BZ-1

REF_5BR3995BZ-1_16W1

Measurement data and graphs

9.8 +18 V rail regulation (LDO input)

As the +15 V output via LDO is derived from the +18 V rail from the transformer, which is also shared by the CoolSET™ V_{CC} , there are several design goals to achieve during normal operating conditions:

- Avoid V_{CC} UVLO (10 V typ.)
- Avoid VCC OVP (25.5 V typ.)
- Meet the specification of the LDO: ($V_{OUT} + 1\sim 2$ V) less than or equal to V_{IN} less than or equal to 30 V; load dependent.

Figure 19 and Table 9 below show that the +18 V rail is operating between 18.51 V and 22.26 V under different load combinations and line conditions, which is well within the design objectives outlined above.

Table 9 +18 V rail line and load regulation

Conditions	12 V/40 mA 5 V/0 A 15 V/0 A (V)	12 V/40 mA 5 V/5 mA 15 V/5 mA (V)	12 V/0.9 A 5 V/5 mA 15 V/5 mA (V)	12 V/0.9 A 5 V/0.3 A 15 V/0.15 A (V)
85 V AC/60 Hz	18.66	18.51	22.26	18.65
115 V AC/60 Hz	18.67	18.52	22.26	18.67
230 V AC/50 Hz	18.67	18.52	22.04	18.64
264 V AC/50 Hz	18.67	18.51	22.01	18.64

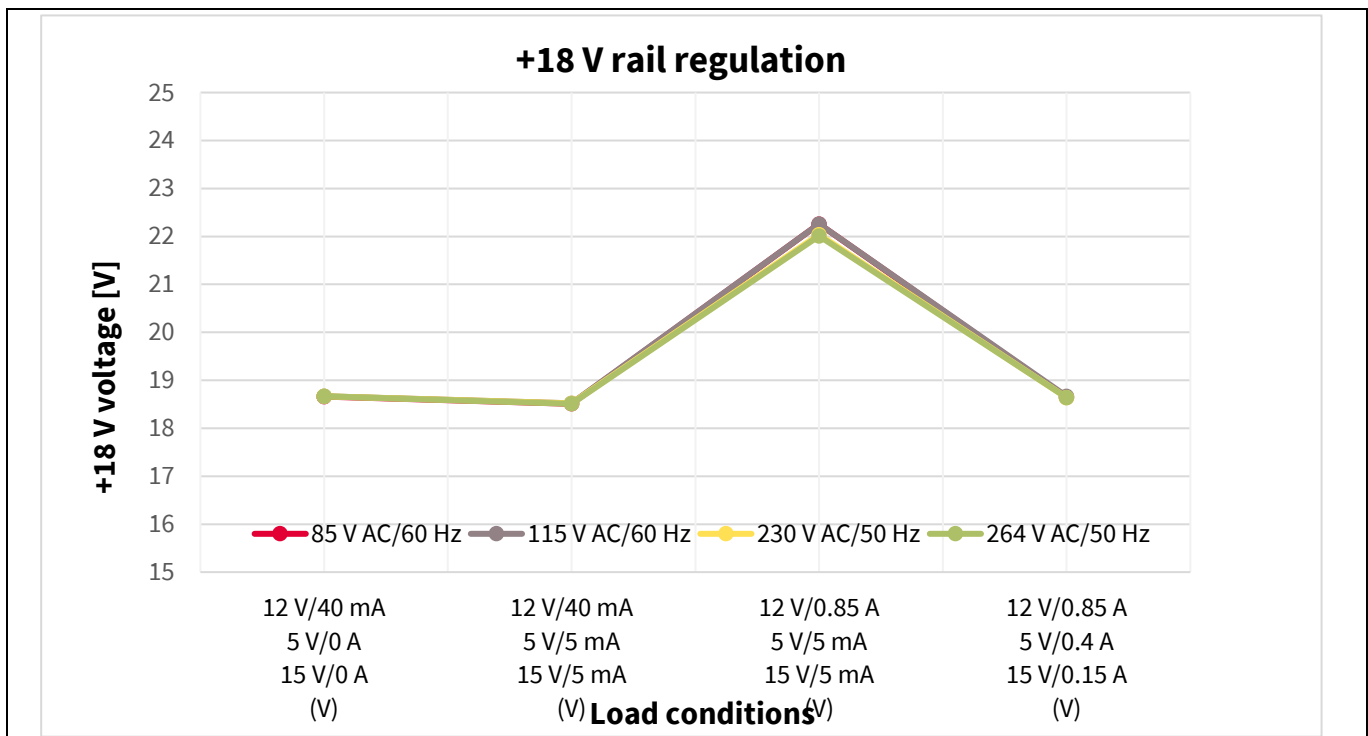

Figure 19 +18 V rail regulation

16 W non-isolated auxiliary power supply for outdoor air conditioner using CoolSET™ ICE5BR3995BZ-1

REF_5BR3995BZ-1_16W1

Waveforms and oscilloscope plots

10 Waveforms and oscilloscope plots

All waveforms and scope plots were recorded with a Teledyne LeCroy 606Zi oscilloscope.

10.1 Start-up at full load

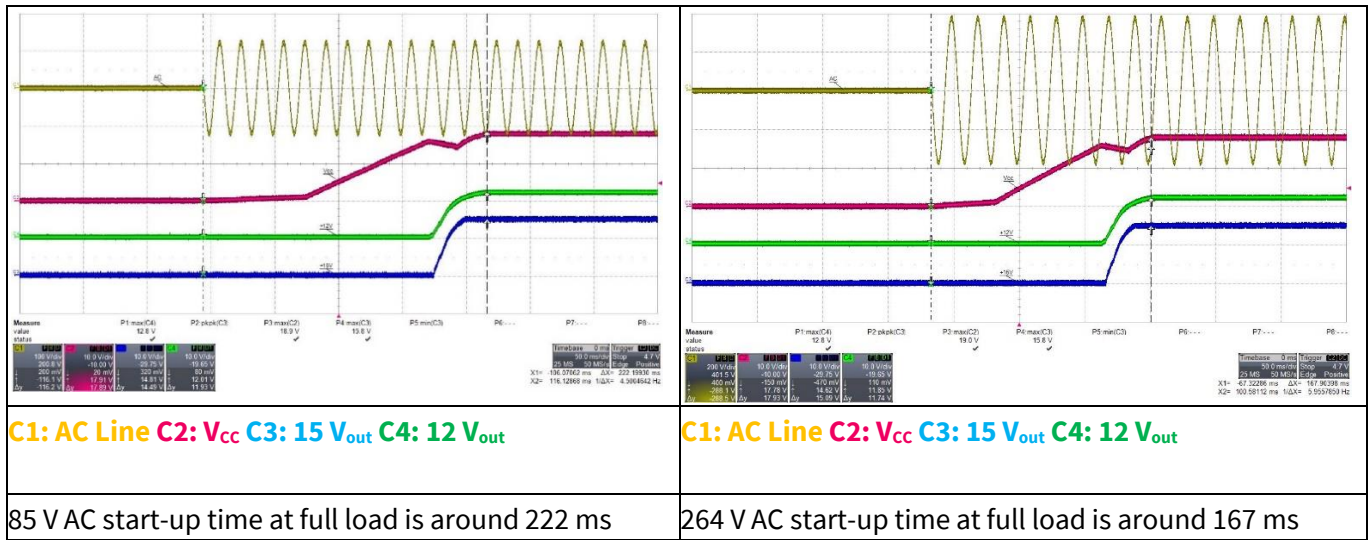

Figure 20 Start-up

10.2 Soft-start at full load

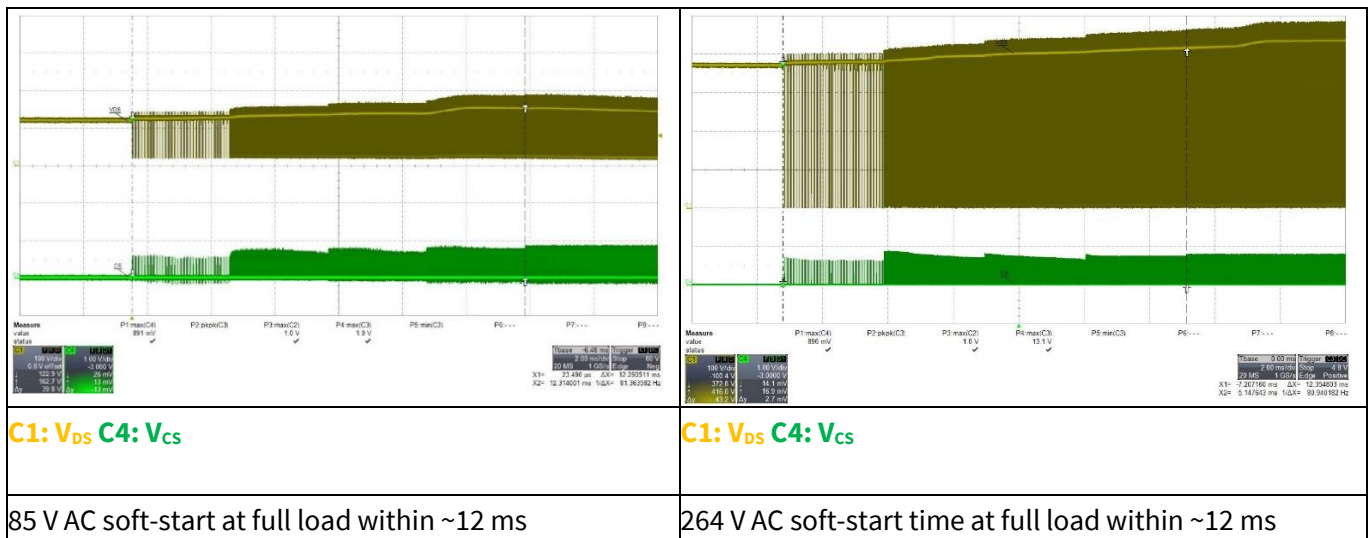

Figure 21 Soft-start

16 W non-isolated auxiliary power supply for outdoor air conditioner using CoolSET™ ICE5BR3995BZ-1

REF_5BR3995BZ-1_16W1

Waveforms and oscilloscope plots

10.3 Drain and CS voltage at full load

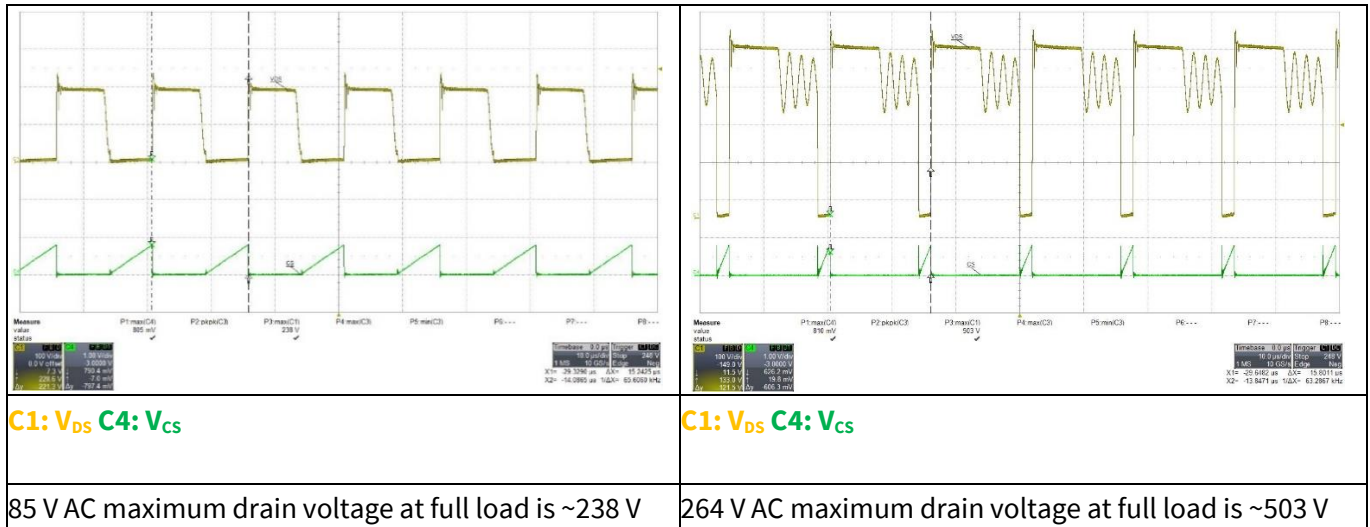

Figure 22 Drain and CS voltage

10.4 Frequency jittering

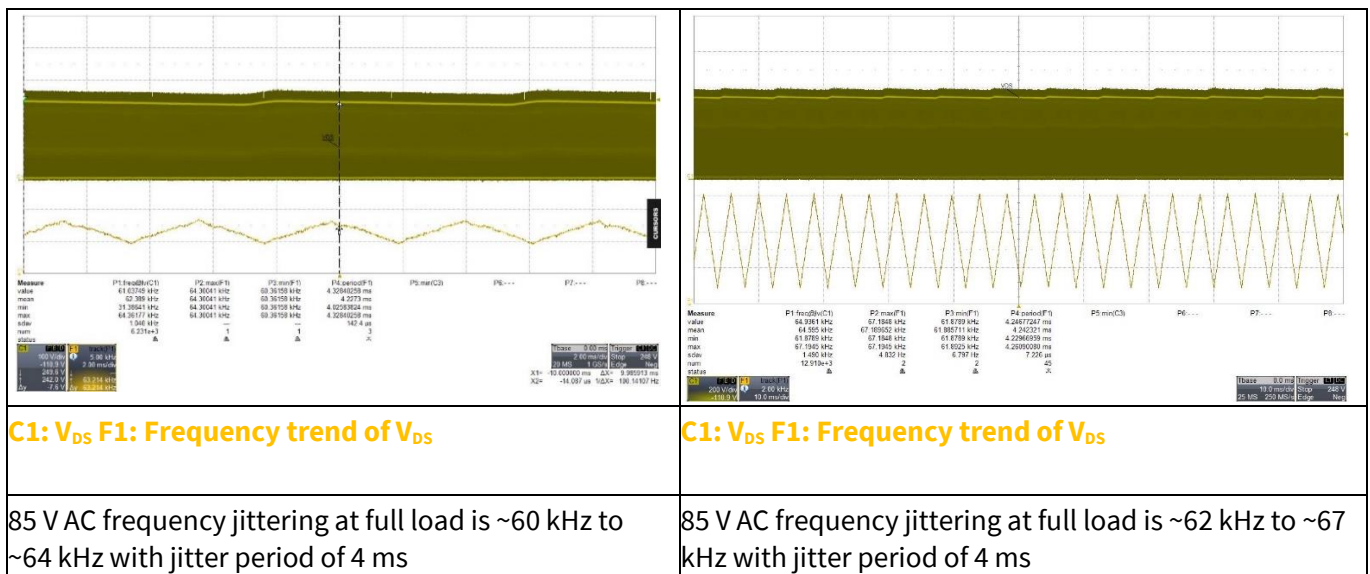

Figure 23 Frequency jittering

16 W non-isolated auxiliary power supply for outdoor air conditioner using CoolSET™ ICE5BR3995BZ-1

REF_5BR3995BZ-1_16W1

Waveforms and oscilloscope plots

10.5 Load-transient response

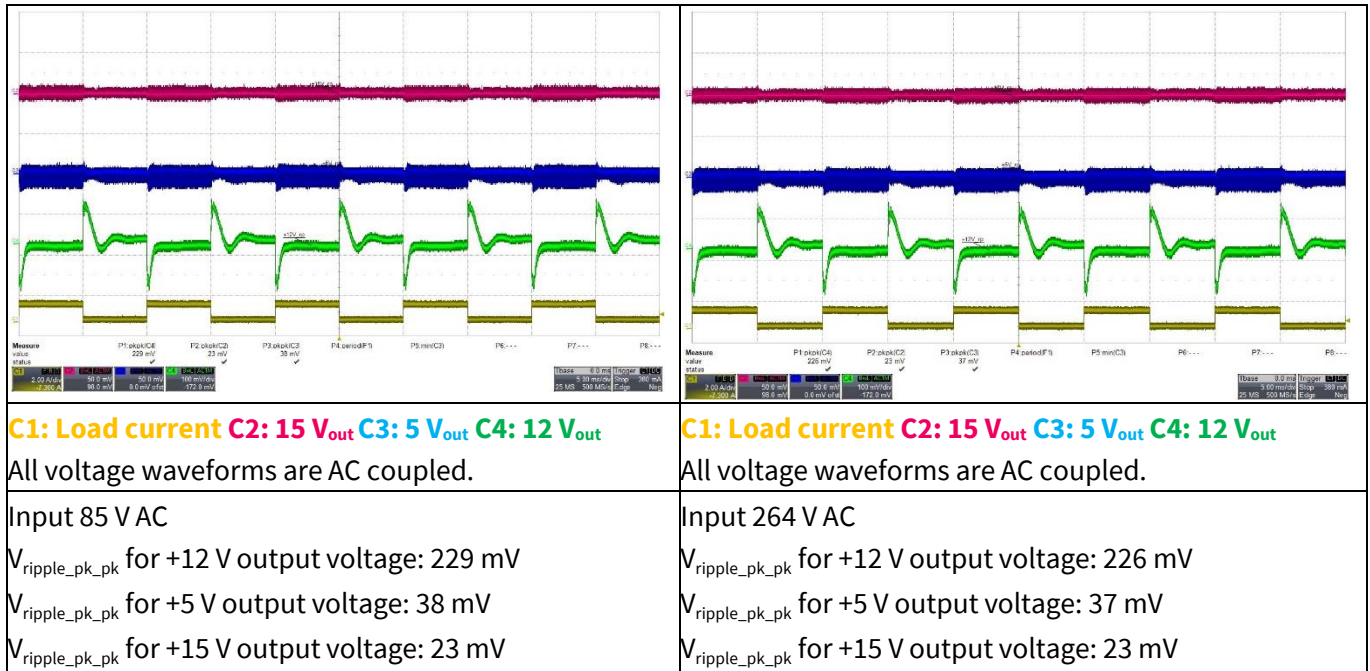

Figure 24 Load-transient response (+12 V output load change from 10 percent to 100 percent at 0.4 A/ μ s slew rate, 100 Hz, +15 V output and +5 V output load are fixed at full load; 20 MHz bandwidth and 10 μ F electrolytic capacitor in parallel with 0.1 μ F ceramic capacitor)

10.6 Output ripple voltage at full load

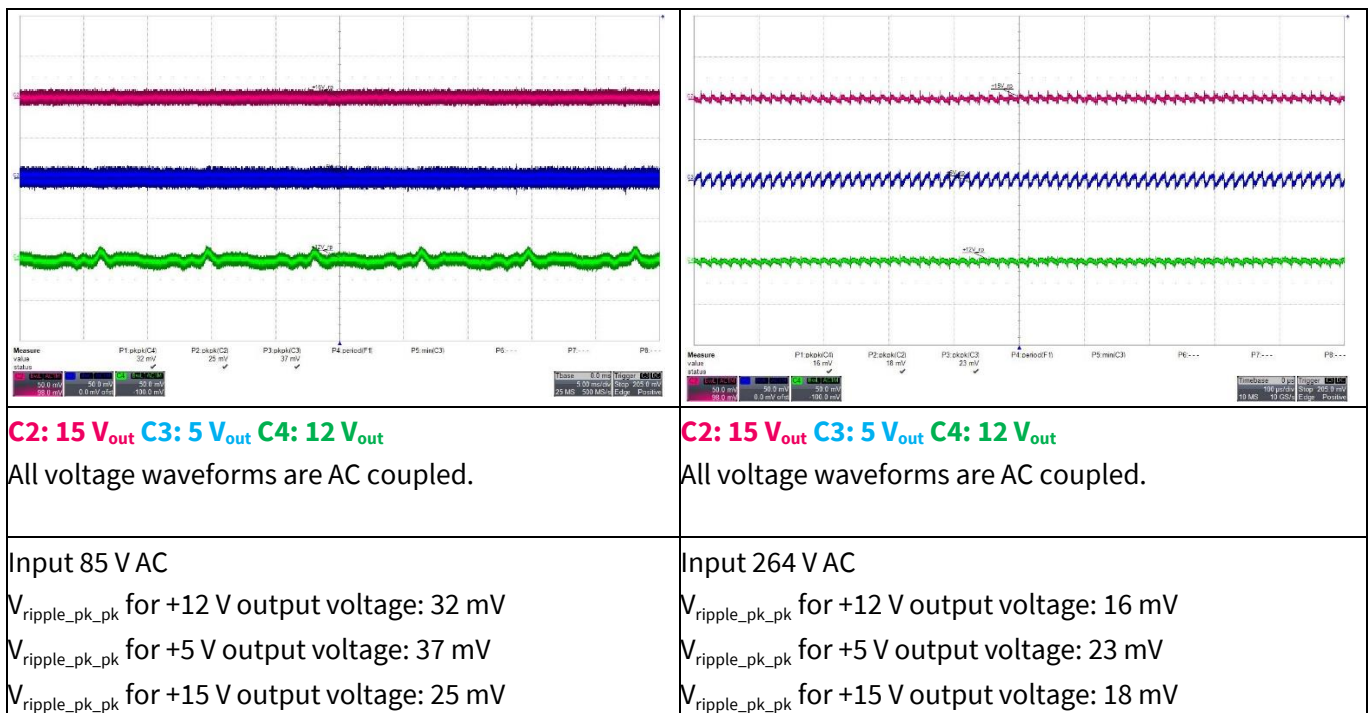

Figure 25 Output ripple voltage at full load. Probe terminals are decoupled with 10 μ F electrolytic and 0.1 μ F ceramic capacitors. Oscilloscope is bandwidth filter limited to 20 MHz

16 W non-isolated auxiliary power supply for outdoor air conditioner using CoolSET™ ICE5BR3995BZ-1

REF_5BR3995BZ-1_16W1

Waveforms and oscilloscope plots

10.7 Output ripple voltage at ABM (minimum load)

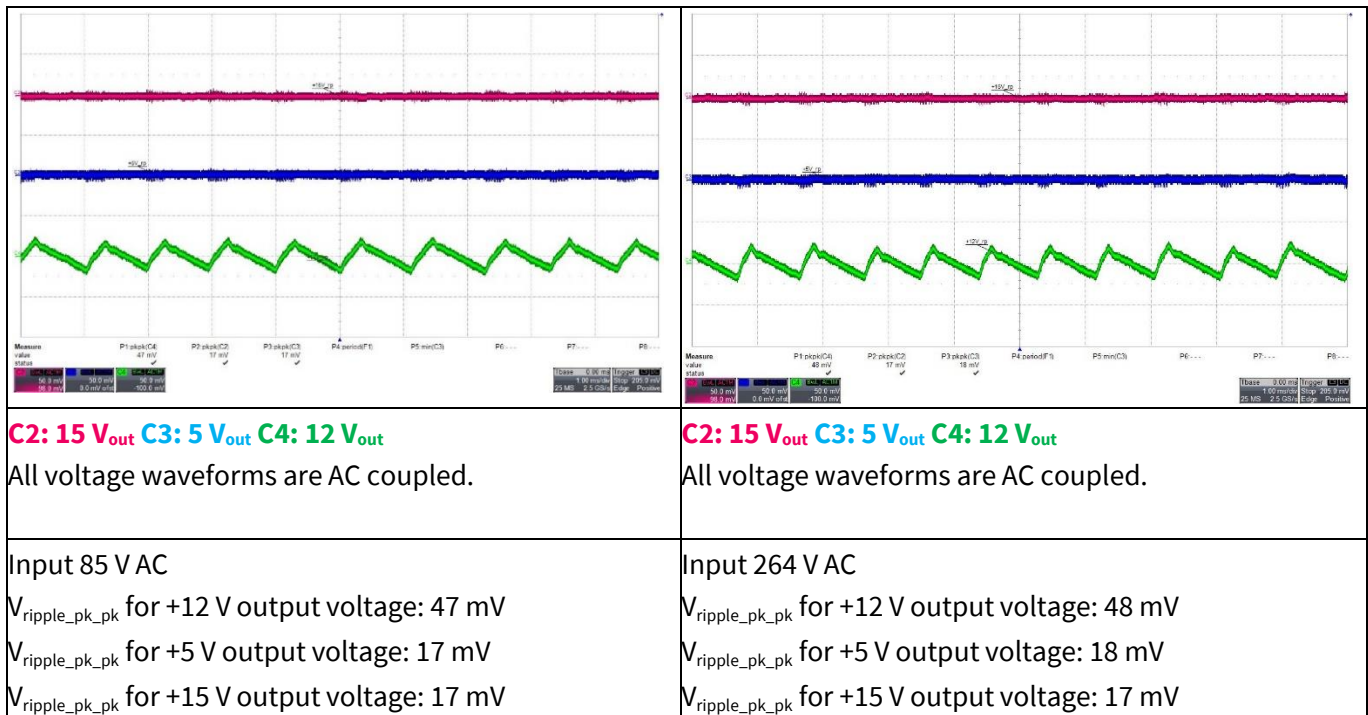

Figure 26 Output ripple voltage at minimum load. Probe terminals are decoupled with 10 μ F electrolytic and 0.1 μ F ceramic capacitors. Oscilloscope is bandwidth filter limited to 20 MHz

10.8 Entering ABM

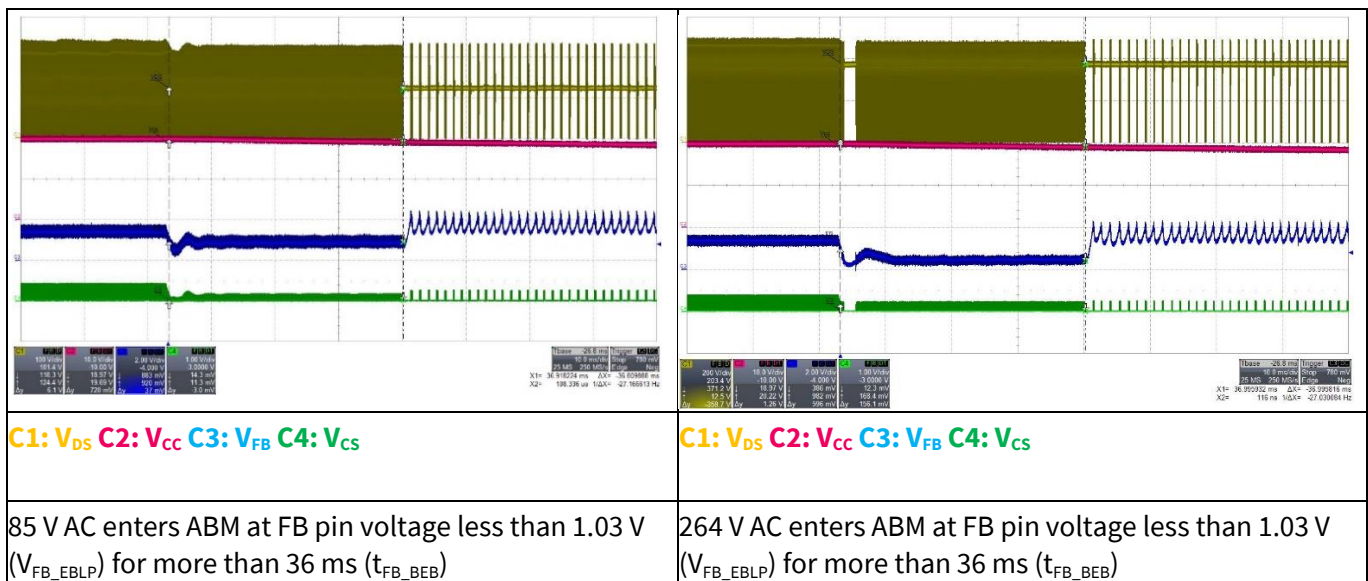

Figure 27 Entering ABM

16 W non-isolated auxiliary power supply for outdoor air conditioner using CoolSET™ ICE5BR3995BZ-1

REF_5BR3995BZ-1_16W1

Waveforms and oscilloscope plots

10.9 During ABM

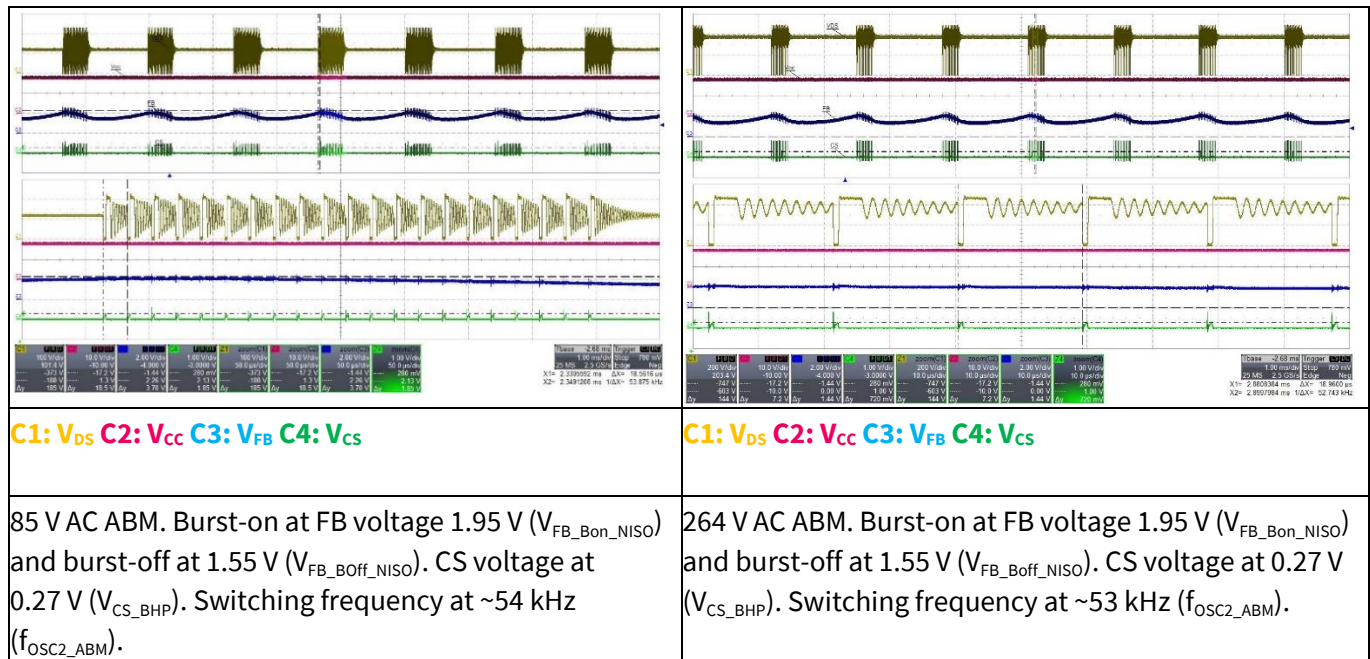

Figure 28 During ABM

10.10 Leaving ABM

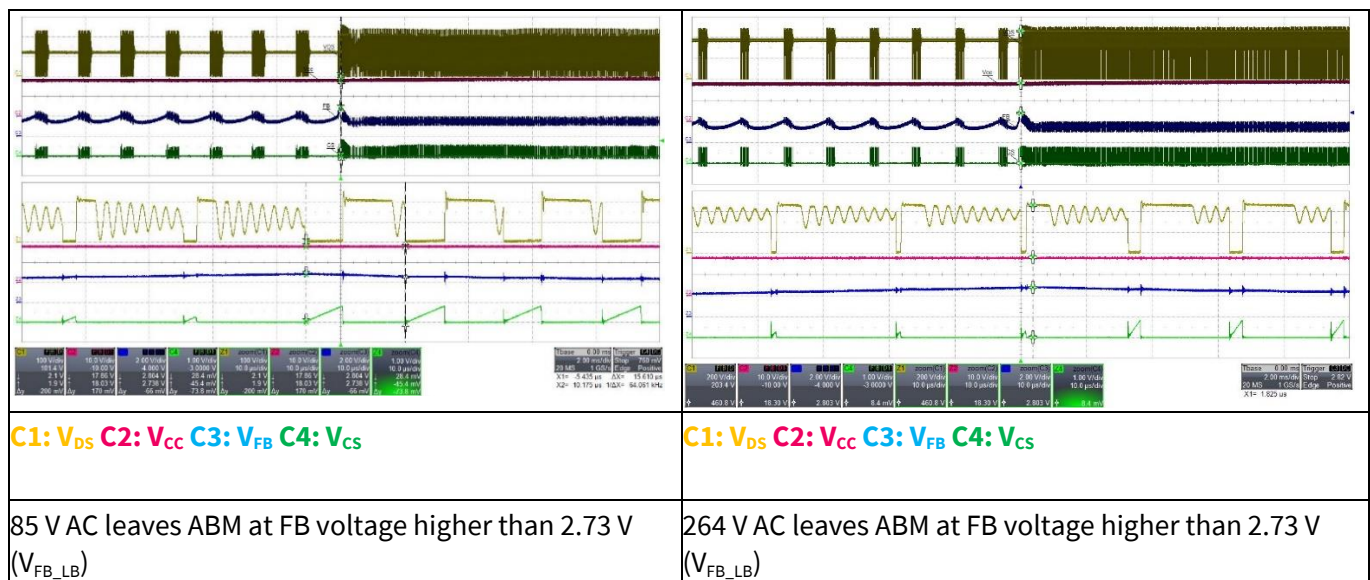

Figure 29 Leaving ABM

16 W non-isolated auxiliary power supply for outdoor air conditioner using CoolSET™ ICE5BR3995BZ-1

REF_5BR3995BZ-1_16W1

Waveforms and oscilloscope plots

10.11 V_{CC} OV/UV protection

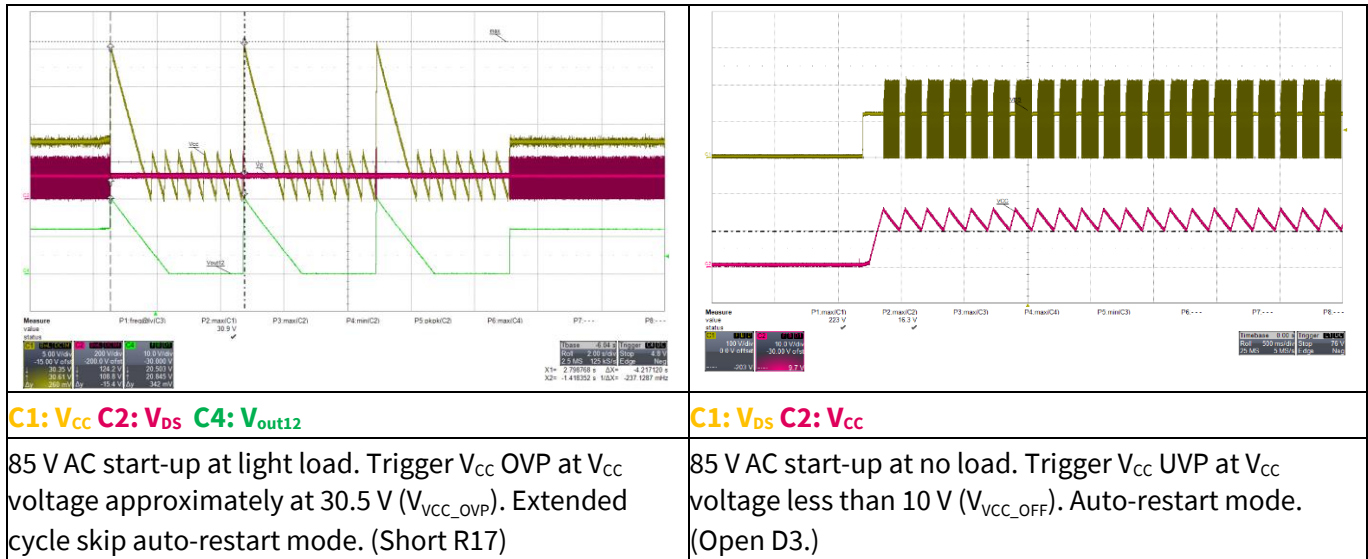

Figure 30 V_{CC} OV/UV protection

10.12 Overload protection

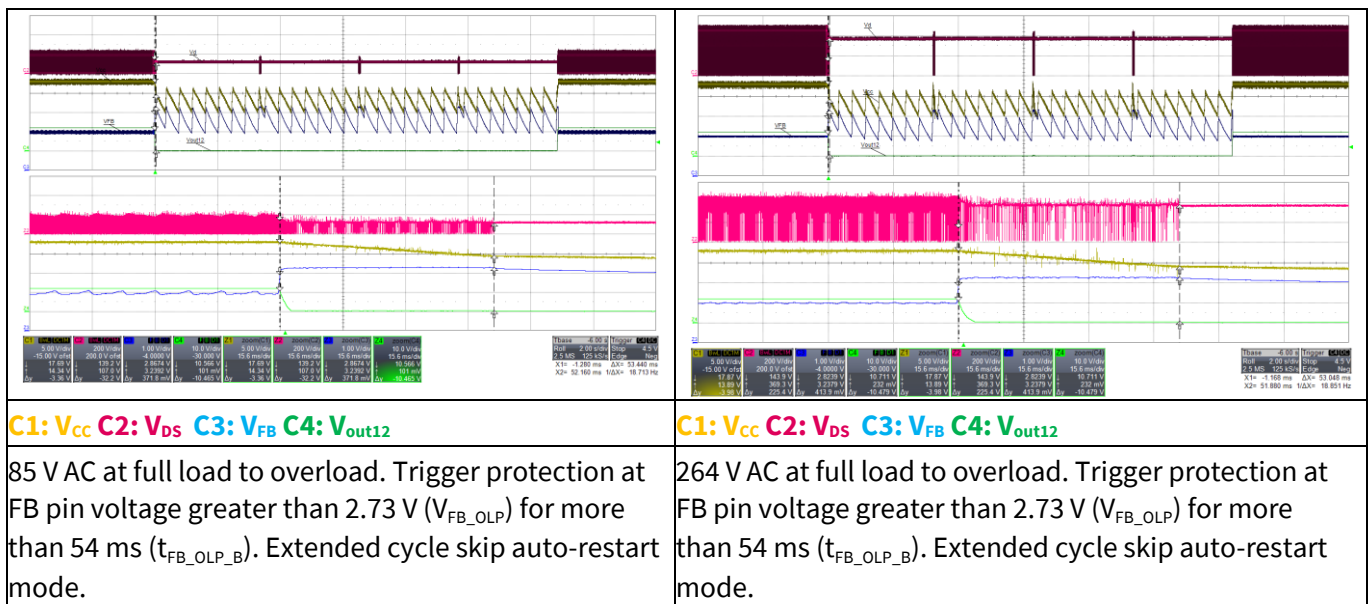

Figure 31 Overload protection

16 W non-isolated auxiliary power supply for outdoor air conditioner using CoolSET™ ICE5BR3995BZ-1

REF_5BR3995BZ-1_16W1

Appendix A: WE transformer specification

11 Appendix A: WE transformer specification

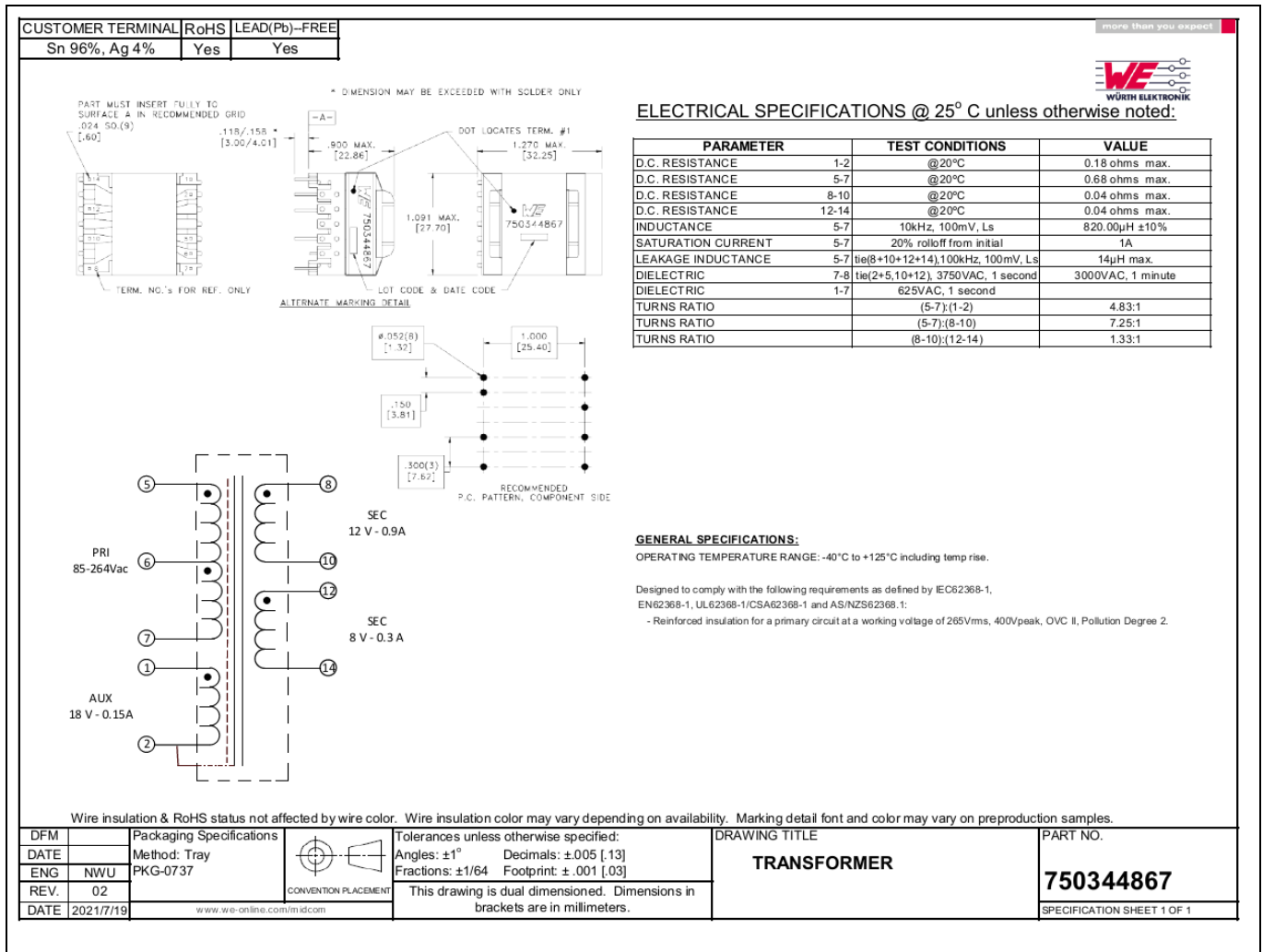

Figure 32 WE transformer specification

16 W non-isolated auxiliary power supply for outdoor air conditioner using CoolSET™ ICE5BR3995BZ-1



REF_5BR3995BZ-1_16W1

References

References

- [1] Infineon Technologies AG: *ICE5xRxxxxBZx-1 datasheet*; [Available online](#)
- [2] Infineon Technologies AG: *CoolSET™ 5th Generation Fixed Frequency Plus flyback design guide*; [Available online](#)
- [3] Infineon Technologies AG: *CoolSET™ 5th Generation Fixed Frequency Plus Calculation tool for flyback*; [Available online](#)

16 W non-isolated auxiliary power supply for outdoor air conditioner using CoolSET™ ICE5BR3995BZ-1

REF_5BR3995BZ-1_16W1

Design support

Design support

Developer community

For a wider discussion with peers from industry to trade ideas regarding Infineon products, we welcome you to actively participate on the [Infineon Developer Community](#).

Technical support

Have technical queries? Consult experts from Infineon to get a fast turn-around by request on the [Technical Support](#) page or a [local sales representative](#)

16 W non-isolated auxiliary power supply for outdoor air conditioner using CoolSET™ ICE5BR3995BZ-1



REF_5BR3995BZ-1_16W1

Revision history

Revision history

Document revision	Date	Description of changes
V 1.0	2024-08-23	Initial release

Trademarks

All referenced product or service names and trademarks are the property of their respective owners.

Edition 2024-08-23

Published by

Infineon Technologies AG

81726 Munich, Germany

**© 2024 Infineon Technologies AG.
All Rights Reserved.**

Do you have a question about this document?

Email: erratum@infineon.com

Document reference

AN074921

Important notice

The information contained in this application note is given as a hint for the implementation of the product only and shall in no event be regarded as a description or warranty of a certain functionality, condition or quality of the product. Before implementation of the product, the recipient of this application note must verify any function and other technical information given herein in the real application. Infineon Technologies hereby disclaims any and all warranties and liabilities of any kind (including without limitation warranties of non-infringement of intellectual property rights of any third party) with respect to any and all information given in this application note.

The data contained in this document is exclusively intended for technically trained staff. It is the responsibility of customer's technical departments to evaluate the suitability of the product for the intended application and the completeness of the product information given in this document with respect to such application.

Please note that this product is not qualified according to the AEC Q100 or AEC Q101 documents of the Automotive Electronics Council.

Warnings

Due to technical requirements products may contain dangerous substances. For information on the types in question please contact your nearest Infineon Technologies office.

Except as otherwise explicitly approved by Infineon Technologies in a written document signed by authorized representatives of Infineon Technologies, Infineon Technologies' products may not be used in any applications where a failure of the product or any consequences of the use thereof can reasonably be expected to result in personal injury.

X-ON Electronics

Largest Supplier of Electrical and Electronic Components

Click to view similar products for [Power Management IC Development Tools](#) category:

Click to view products by [Infineon](#) manufacturer:

Other Similar products are found below :

[EVB-EP5348UI](#) [BQ25010EVM](#) [ISL80019AEVAL1Z](#) [ISLUSBI2CKIT1Z](#) [ISL8002AEVAL1Z](#) [ISL91108IIA-EVZ](#) [ISL28022EVKIT1Z](#)
[STEVAL-ISA008V1](#) [DRI0043](#) [KITPF8100FRDMEVM](#) [NCP10671B05GEVB](#) [EVB-EN6337QA](#) [SAMPLEBOXILD8150TOBO1](#)
[AP62300WU-EVM](#) [KITA2GTC387MOTORCTRTOBO1](#) [AEK-MOT-TK200G1](#) [EVLONE65W](#) [STEVAL-ILH006V1](#) [STEVAL-IPE008V2](#)
[STEVAL-IPP001V2](#) [STEVAL-ISA013V1](#) [STEVAL-ISA067V1](#) [STEVAL-ISQ002V1](#) [TPS2306EVM-001](#) [TPS2330EVM-185](#)
[TPS40001EVM-001](#) [SECO-HVDCDC1362-15W-GEVB](#) [BTS7030-2EPA](#) [LT8638SJV#WPBF](#) [LTC3308AIV#WTRPBF](#) [TLT807B0EPV](#)
[BTS71033-6ESA](#) [EV13N91A](#) [EASYPIC V8 OVER USB-C](#) [EV55W64A](#) [CLICKER 4 FOR STM32F4](#) [EASYMX PRO V7A FOR STM32](#)
[CLICKER 4 FOR PIC18F](#) [Si8285_86v2-KIT](#) [NCP-NCV51752D2PAK3LGEVB](#) [ISL81807EVAL1Z](#) [EVALM7HVIGBTTPFCINV4TOBO1](#)
[903-0300-000](#) [902-0173-000](#) [903-0301-000](#) [ROA1286023/1](#) [REFSHA35IMD111TSYSTOBO1](#) [150037482](#) [SABMB629](#) [TDINV3000W50B-](#)
[KIT](#)