

# ICC80QSG 84 W AC-DC reference design #3 with IPN70R450P7S

For power tool battery charger with 110 V AC/230 V AC rated input and constant current (CC) output up to 4 A

## About this document



### Scope and purpose

This document is an engineering report for the 84 W AC-DC converter reference design #3 (orderable part number: REFICC80QSG84W3BPA), which uses Infineon's **ICC80QSG flyback controller** and **IPN70R450P7S** MOSFET.

This reference design board can be used for battery charging applications by adding externally both the battery safety switch and the charging profile control circuits. Please refer to the test setup and safety information section of this document for more information.

### Intended audience

Power supply design engineers and field application engineers.

## Table of contents

<b>About this document</b> .....	<b>1</b>
<b>Table of contents</b> .....	<b>1</b>
<b>1 Test setup and safety information</b> .....	<b>2</b>
<b>2 Design features</b> .....	<b>4</b>
<b>3 Board specifications</b> .....	<b>5</b>
<b>4 Schematic and PCB layout</b> .....	<b>7</b>
<b>5 Performance</b> .....	<b>9</b>
5.1 Efficiency.....	9
5.2 Standby power.....	10
5.3 Brown-in and brown-out protection.....	11
5.4 Thermal test.....	12
5.5 Conducted emissions (EN 55022 class B).....	14
<b>6 Bill of materials and transformer specifications</b> .....	<b>16</b>
6.1 BOM.....	16
6.2 Transformer specifications.....	18
<b>Revision history</b> .....	<b>19</b>

# 1 Test setup and safety information

This AC-DC reference design is a flyback converter with secondary-side regulated (SSR) constant current (CC) output. The CC output set-point is adjustable with a 0 to 3 V analog input signal.

As shown in **Figure 1**, to use this reference design board for battery charging application testing, it is mandatory to add externally both the battery safety switch and the charging profile control circuits, which work according to the board and battery specification.

**Attention:** For safety reasons, it is prohibited to connect this reference design board to any battery without adding externally the battery safety switch and charging profile control circuits.

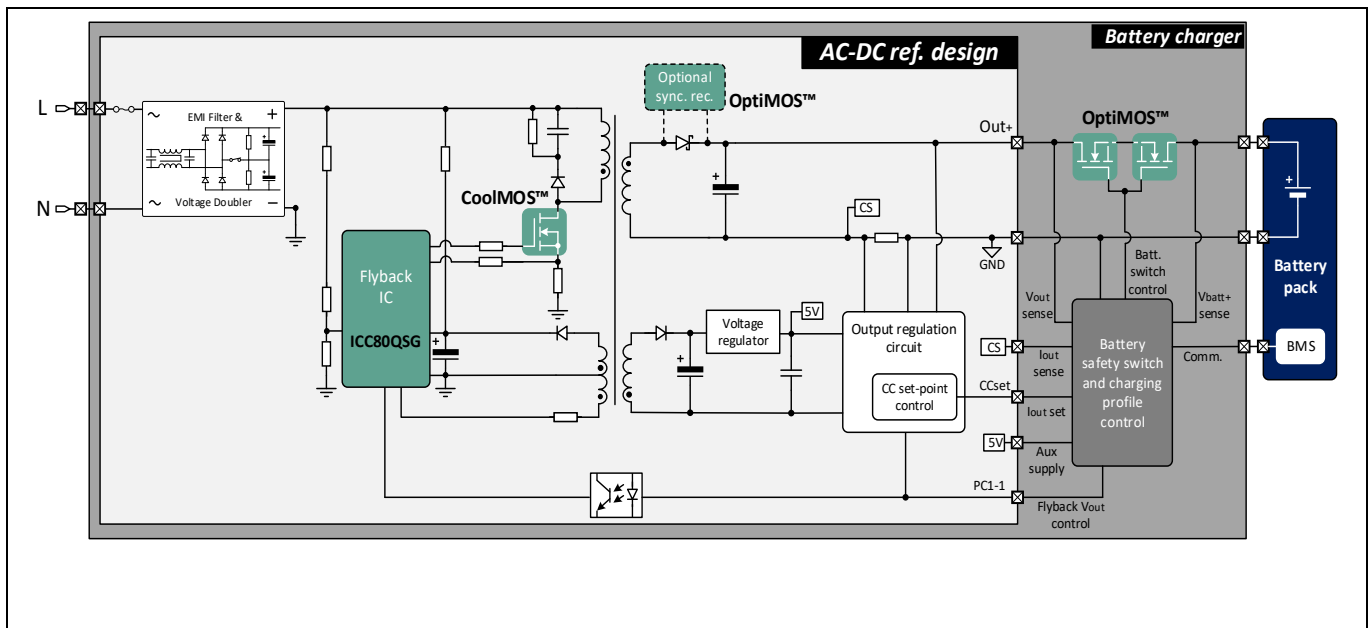

**Figure 1** Test setup of AC-DC reference design with connections to external battery safety switch and charging profile control circuits, for battery charging application testing

Alternatively, a test setup using the electronic load (in constant voltage/CV mode) and DC source (for adjusting the CC set-point) can be done based on **Figure 2**.



**Figure 2** Test setup with electronic load and adjustable CC set-point using DC source

**Attention:** Lethal voltages are present on this reference design. Do not operate the board unless you are trained to handle high-voltage (HV) circuits. Do not leave this board unattended when it is powered up.

# ICC80QSG 84 W AC-DC reference design #3 with IPN70R450P7S

For power tool battery charger with 110 V AC / 230 V AC rated input and constant current (CC) output up to 4 A



## Test setup and safety information

For EMI testing with full output power of 84 W, the test setup in **Figure 3** is recommended.



**Figure 3** EMI test setup with full output power

For no-load system standby power measurement, the test setup in **Figure 4** is recommended.



**Figure 4** No-load system standby power test setup

### Design features

## 2 Design features

- Secondary-side regulation (SSR), with adjustable constant current (CC) output set-point from 0 to 4 A
- Supports wide output load range from 11 to 21 V (refer to the chapter “[Board specifications](#)” for details)
- High efficiency and low EMI with quasi-resonant (QR) valley switching
- Cost-effective flyback MOSFET with high performance, using [CoolMOS™ P7 in SOT-223 package](#)
- Full power more than 91 percent at 230 V<sub>RMS</sub> AC input and more than 90 percent at 110 V<sub>RMS</sub>
- Four-point average efficiency more than 91 percent at high-line input and more than 90 percent at low-line input for 21 V output
- Burst mode with reduced gate driver output voltage for lower standby power
- System standby power less than 180 mW at 110 V<sub>RMS</sub> AC input and less than 250 mW at 230 V<sub>RMS</sub> AC input
- Supports IC disabling with external pull-down signal (jumper)
- Configurable hysteresis of brown-in and brown-out levels
- Adaptive brown-out level triggering based on bus voltage ripple, to better protect primary components from overheating and saturation with higher brown-out level at higher power transfer
- Comprehensive set of protections: internal overtemperature protection (OTP), output overvoltage protection (OVP), V<sub>CC</sub> OVP, primary-side overcurrent protection (OCP), brown-in and brown-out protection
- Soft-start to reduce component stress during turn-on

Board specifications

### 3 Board specifications

Table 1 lists the electrical specifications of the evaluation board.

**Table 1 Electrical specifications**

Specification	Symbol	Value	Unit
Normal operational AC input voltage	V <sub>AC</sub>	90 to 130 176 to 264	V <sub>RMS</sub>
Normal operational AC input frequency	F <sub>line</sub>	47 to 63	Hz
CC output set-point	I <sub>out,setpoint</sub>	0 to 4.0	A
CC output set-point control voltage (see Figure 5 for details)	CC <sub>set</sub>	0 to 3	V
Output load range (I <sub>out,setpoint</sub> = 0 to 4 A)	V <sub>load,CV</sub>	11 to 21	V
Input power under no-load condition (V <sub>AC</sub> = 230 V <sub>RMS</sub> ; F <sub>line</sub> = 50 Hz; output open)	P <sub>in,no-load</sub>	230	mW
Input power under no-load condition (V <sub>AC</sub> = 110 V <sub>RMS</sub> ; F <sub>line</sub> = 50 Hz; output open)	P <sub>in,no-load</sub>	170	mW
Steady-state output voltage limit under no-load condition	V <sub>out,FB,limit</sub>	Around 23.8	V
Efficiency at full output power (V <sub>AC</sub> = 230 V <sub>RMS</sub> ; output load = 21 V; I <sub>out,setpoint</sub> = 4.0 A)	η	92.0	%
Efficiency at full output power (V <sub>AC</sub> = 110 V <sub>RMS</sub> ; output load = 21 V; I <sub>out,setpoint</sub> = 4.0 A)	η	90.2	%
Four-point average efficiency – high-line low (V <sub>AC</sub> = 176 V <sub>RMS</sub> ; output load = 21 V; I <sub>out</sub> = 1 A, 2 A, 3 A and 4 A)	η <sub>avg,4-point1</sub>	92.0	%
Four-point average efficiency – high-line high (V <sub>AC</sub> = 264 V <sub>RMS</sub> ; output load = 21 V; I <sub>out</sub> = 1 A, 2 A, 3 A and 4 A)	η <sub>avg,4-point2</sub>	91.9	%
Four-point average efficiency – low-line low (V <sub>AC</sub> = 90 V <sub>RMS</sub> ; output load = 21 V; I <sub>out</sub> = 1 A, 2 A, 3 A and 4 A)	η <sub>avg,4-point1</sub>	90.5	%
Four-point average efficiency – low-line high (V <sub>AC</sub> = 130 V <sub>RMS</sub> ; output load = 21 V; I <sub>out</sub> = 1 A, 2 A, 3 A and 4 A)	η <sub>avg,4-point2</sub>	91.2	%

Board specifications

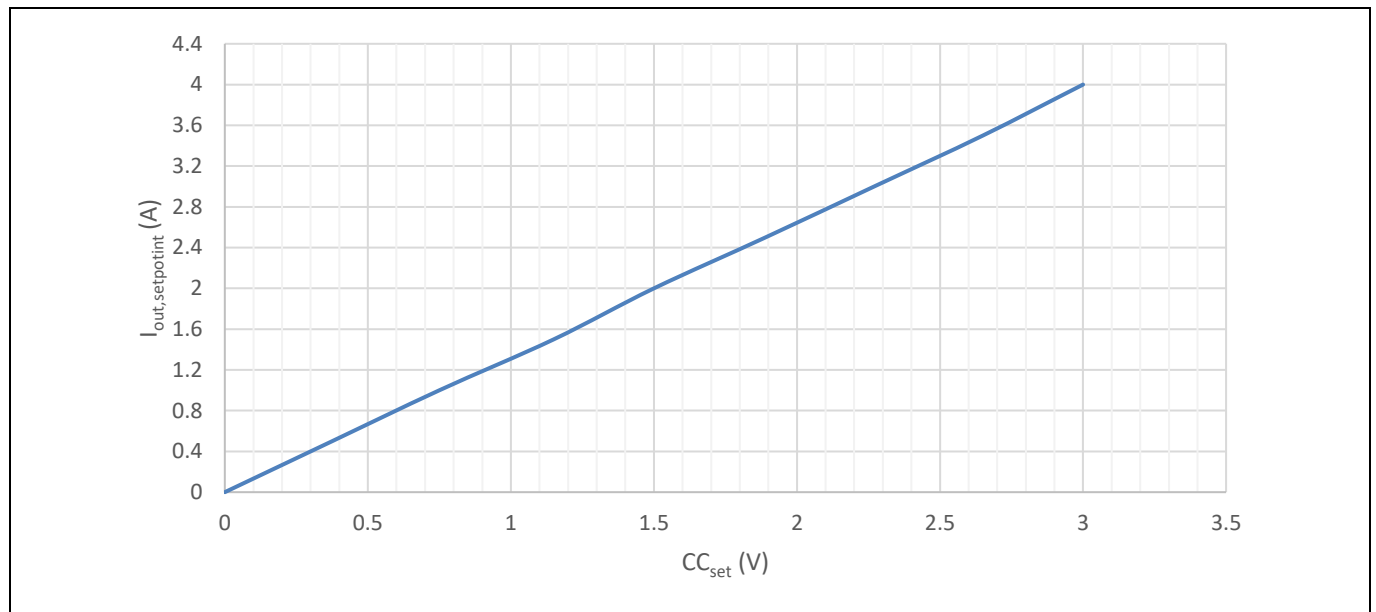

Figure 5  $I_{out,setpoint}$  control based on  $CC_{set}$  input signal

## 4 Schematic and PCB layout

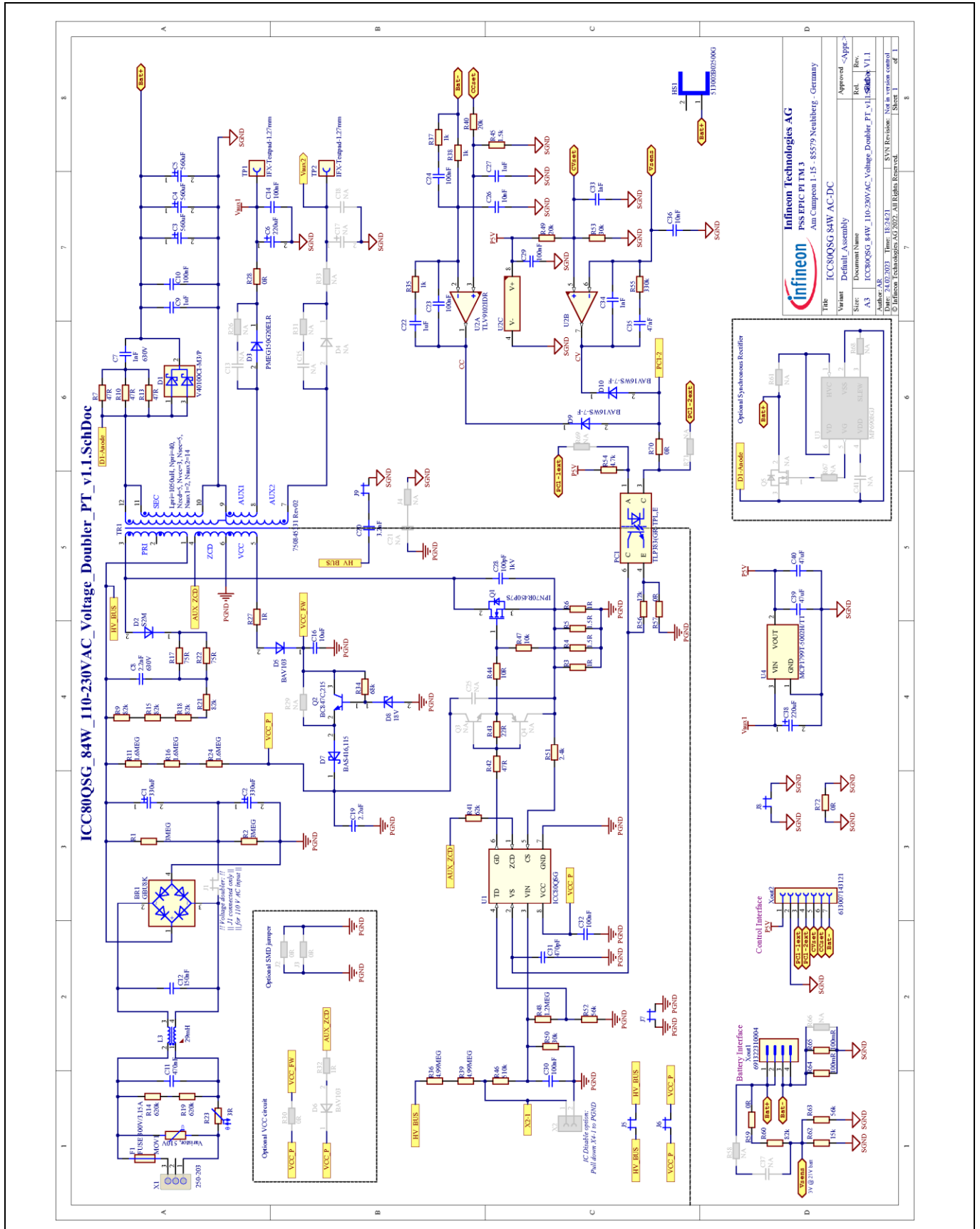

Figure 6 Reference design board schematic



# ICC80QSG 84 W AC-DC reference design #3 with IPN70R450P7S

For power tool battery charger with 110 V AC / 230 V AC rated input and constant current (CC) output up to 4 A



## Schematic and PCB layout

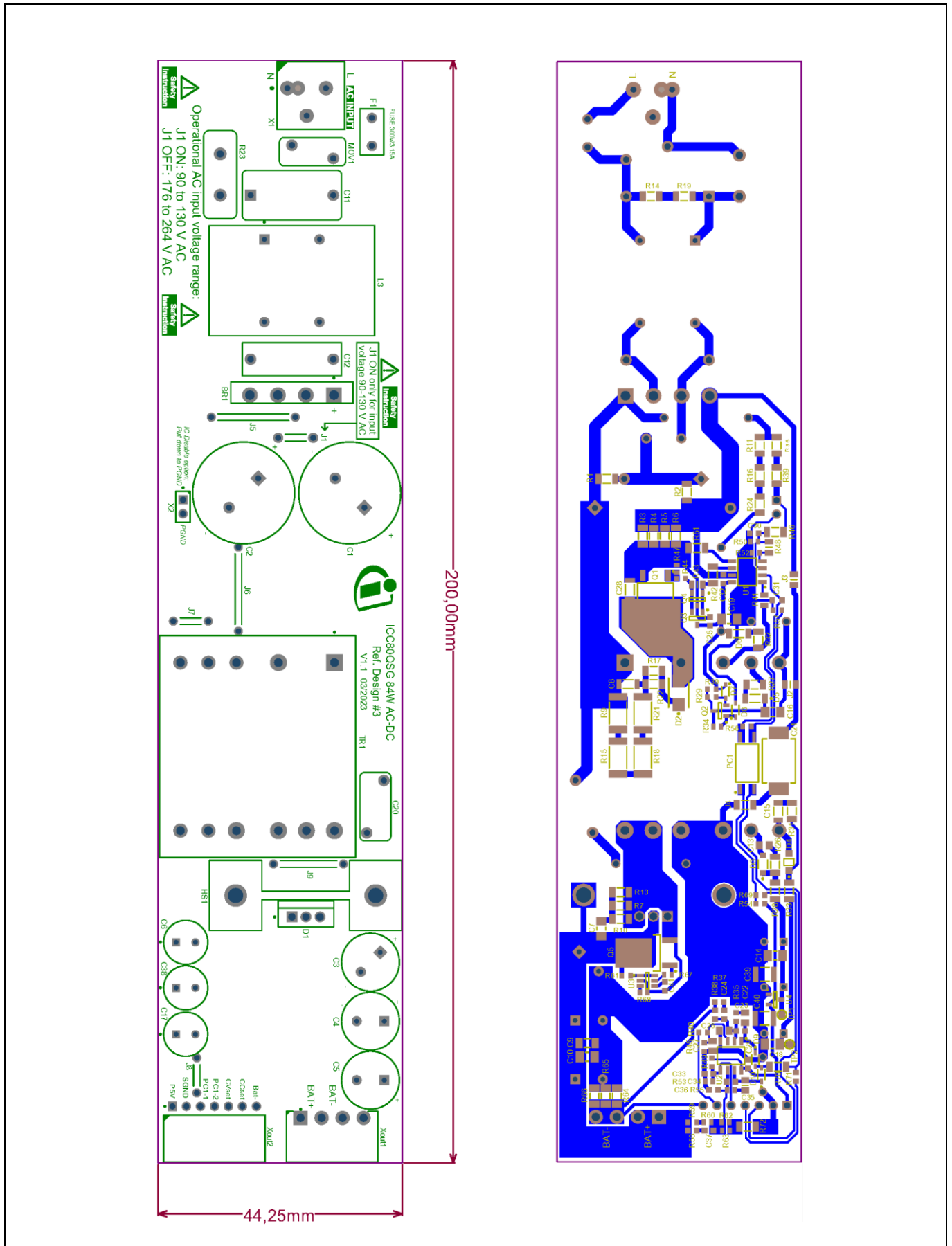

Figure 7 PCB top (left) and bottom (right) layout of the reference design board



Performance

## 5 Performance

The results shown in this section are based on the evaluation of a single board, at room temperature.

### 5.1 Efficiency

The efficiency at full output power (84 W) is measured at more than 90 percent with typical V AC of 110 V<sub>RMS</sub>, and more than 88.5 percent across the low-line V AC range, as shown in [Figure 8](#).

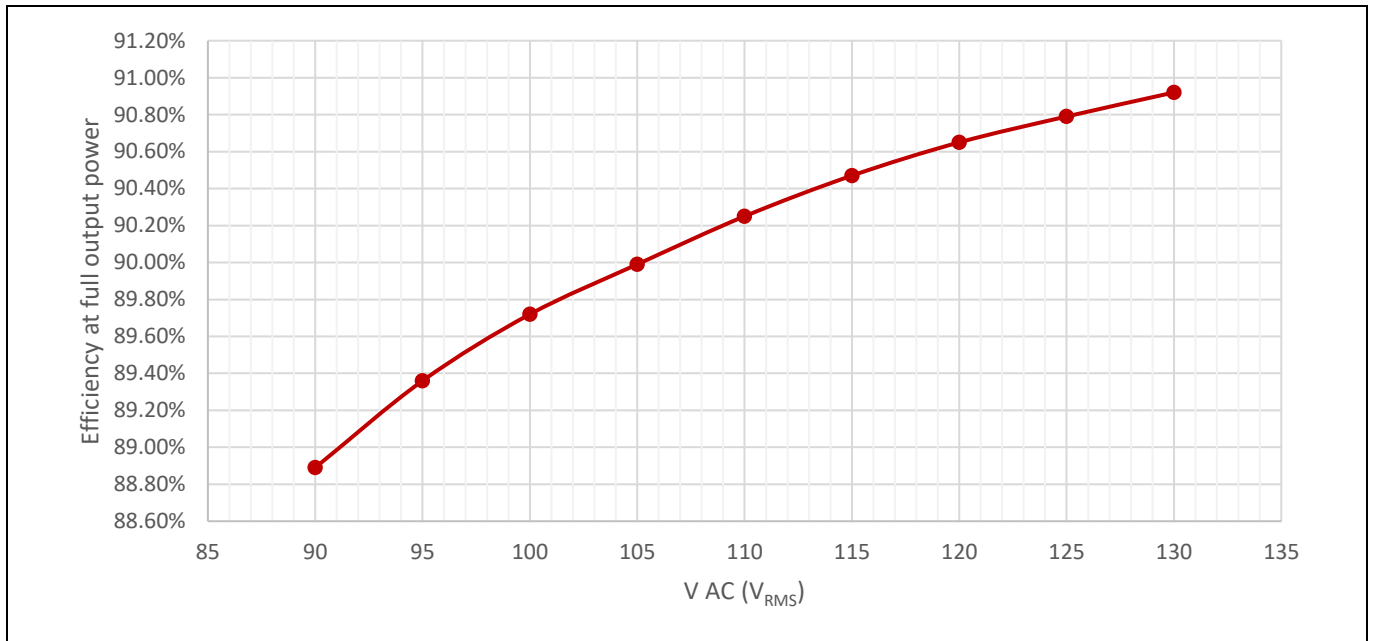

**Figure 8 Efficiency at low-line input and full output power (84 W)**

For high-line input voltage range, the efficiency at full output power (84 W) is more than 91 percent and 92 percent at typical V AC of 230 V<sub>RMS</sub>, as shown in [Figure 9](#).

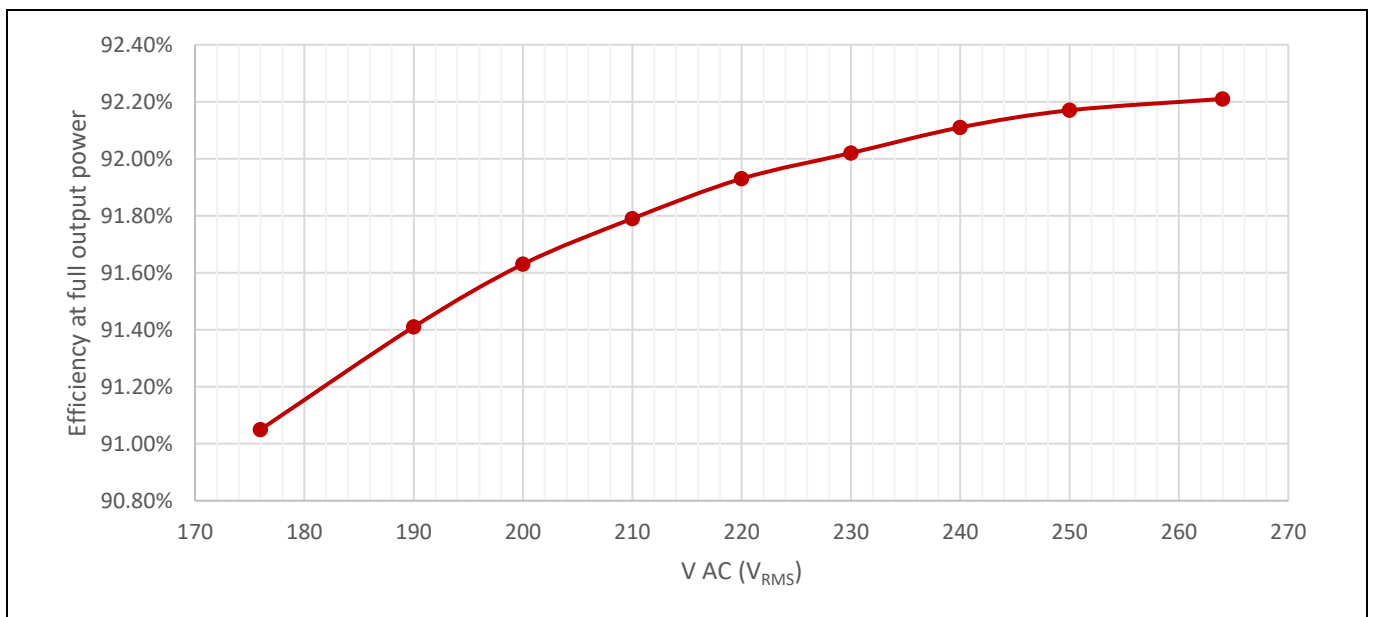

**Figure 9 Efficiency at high-line input and full output power (84 W)**

**Performance**

The four-point average efficiency at high-line input voltage range is measured at more than 91 percent with 21 V load, and in the range of 88 percent to 89 percent with 12 V load, as shown in [Table 2](#).

**Table 2 Four-point average efficiency at high-line input**

V AC (V <sub>RMS</sub> )	Output load (V)	I <sub>out,setpoint</sub> (mA)	I <sub>out,setpoint</sub> (%)	Efficiency (%)	Four-point average efficiency (%)
176	21	4000	100	91.05	92.00
		3000	75	92.01	
		2000	50	92.67	
		1000	25	92.27	
264	21	4000	100	92.21	92.02
		3000	75	92.57	
		2000	50	92.39	
		1000	25	90.89	
176	12	4000	100	89.62	90.18
		3000	75	90.57	
		2000	50	91.08	
		1000	25	89.46	
264	12	4000	100	90.01	89.01
		3000	75	90.22	
		2000	50	89.38	
		1000	25	86.41	

In the low-line input voltage range, the four-point average efficiency is measured at more than 90 percent with 21 V load, and more than 88 percent with 12 V load, as shown in [Table 3](#).

**Table 3 Four-point average efficiency at low-line input**

V AC (V <sub>RMS</sub> )	Output load (V)	I <sub>out,setpoint</sub> (mA)	I <sub>out,setpoint</sub> (%)	Efficiency (%)	Four-point average efficiency (%)
90	21	4	100	88.89	90.52
		3	75	90.25	
		2	50	91.41	
		1	25	91.51	
130	21	4	100	90.92	91.19
		3	75	91.56	
		2	50	91.82	
		1	25	90.45	
90	12	4	100	88.03	89.12
		3	75	89.28	
		2	50	90.15	
		1	25	89.02	
130	12	4	100	89.02	88.58
		3	75	89.45	
		2	50	89.02	
		1	25	86.82	

**5.2 Standby power**

Under no-load condition, the input power measurement indicates 160 mW at V AC of 110 V<sub>RMS</sub> and 230 mW at V AC of 230 V<sub>RMS</sub>, as shown in [Figure 10](#) and [Figure 11](#).

Performance

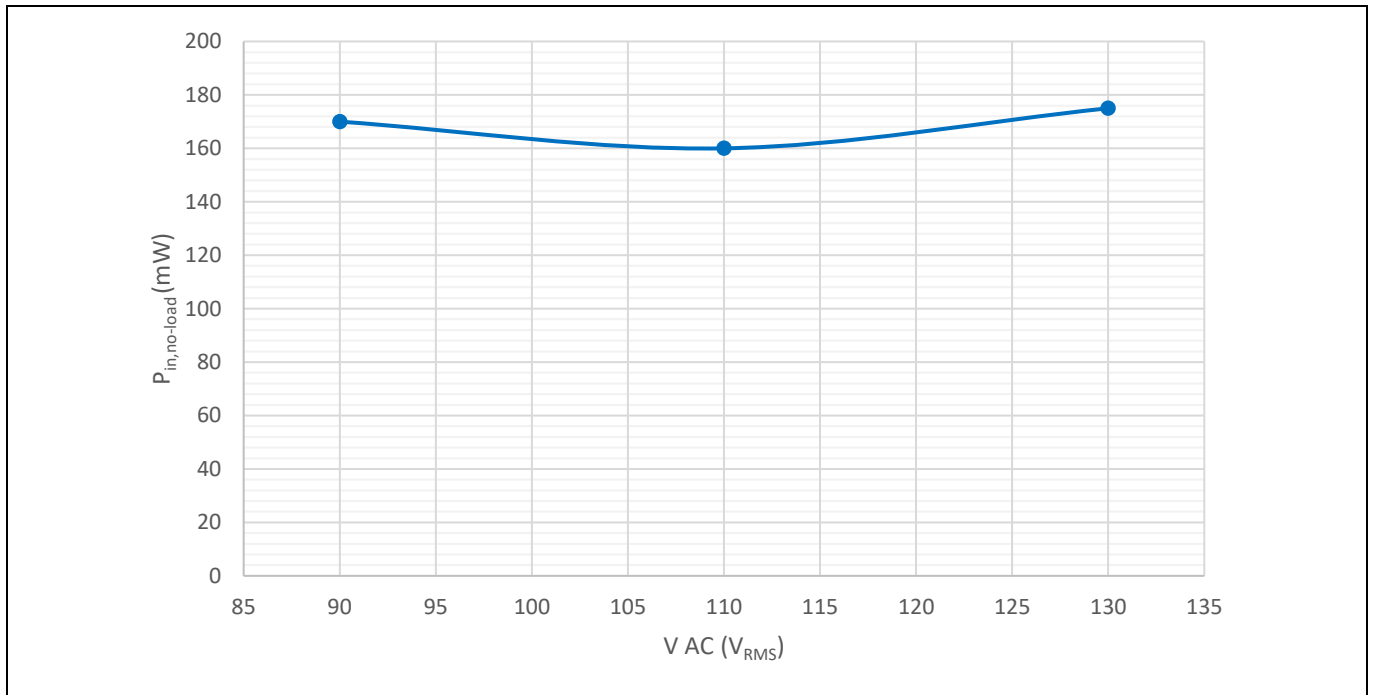

Figure 10 Input power under no-load condition at low-line input

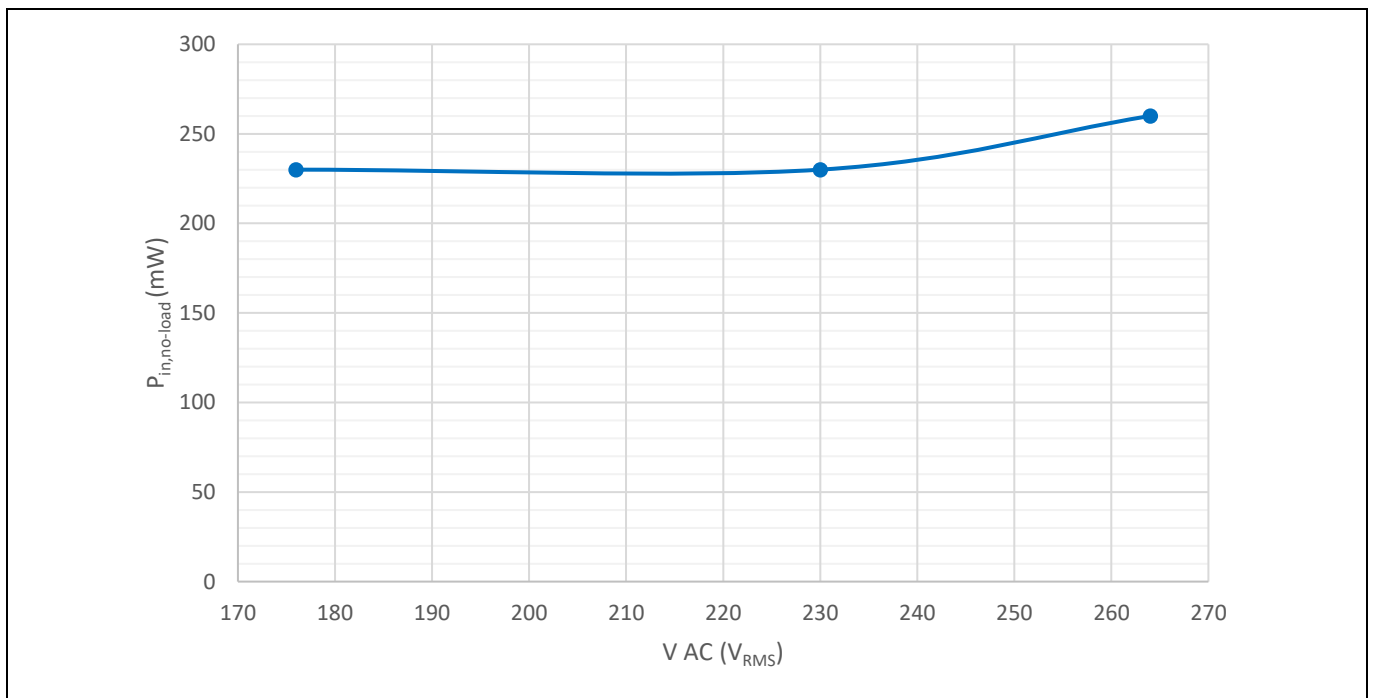

Figure 11 Input power under no-load condition at high-line input

### 5.3 Brown-in and brown-out protection

ICC80QSG features not only the configurable hysteresis between brown-in and brown-out, but also adaptive brown-out level triggering based on bus voltage ripple.

Performance

As shown in Table 4 and Table 5, with these features, this reference design demonstrates a higher brown-out level at higher power transfer, while still ensuring sufficient hysteresis between brown-in and brown-out. As a result, ICC80QSG can better protect the primary components from overheating and saturation when input undervoltage condition occurs.

**Table 4 Brown-in test result**

V AC range	F <sub>line</sub> (Hz)	Output load (V)	I <sub>out,setpoint</sub> (mA)	I <sub>out,setpoint</sub> (%)	Brown-in V AC (V <sub>RMS</sub> )
High-line	50	21	0	0%	170.8
			4000	100%	
Low-line			0	0%	85.8
			4000	100%	

**Table 5 Brown-out test result**

V AC range	F <sub>line</sub> (Hz)	Output load (V)	I <sub>out,setpoint</sub> (mA)	I <sub>out,setpoint</sub> (%)	Brown-out V AC (V <sub>RMS</sub> )
High-line	50	21	0	0%	141.9
			4000	100%	151.8
Low-line			0	0%	71.3
			4000	100%	80.5

**5.4 Thermal test**

The open-frame thermal measurement is done after one hour of operation with full output power (84 W), using an infrared (IR) thermography camera. The ambient temperature is approximately 22°C.

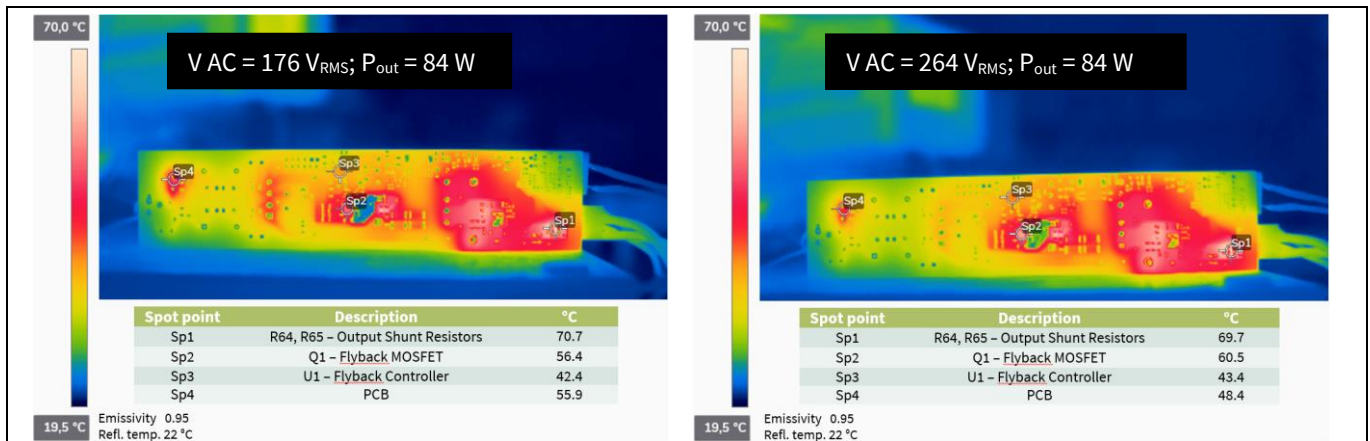

**Figure 12 IR thermal image of PCB bottom components at high-line input**

Performance

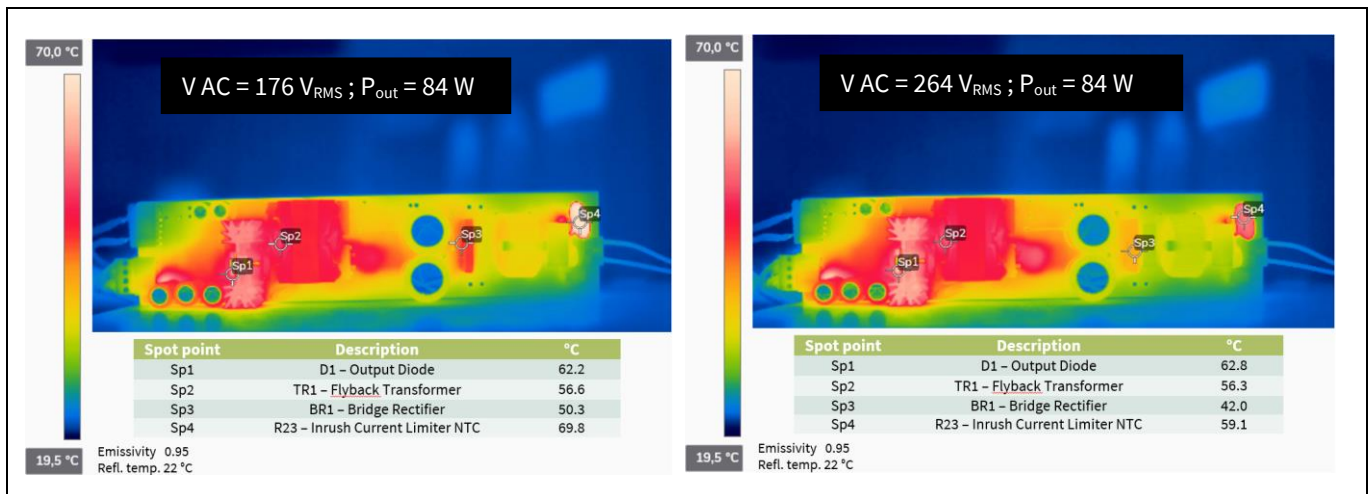

Figure 13 IR thermal image of PCB top components at high-line input

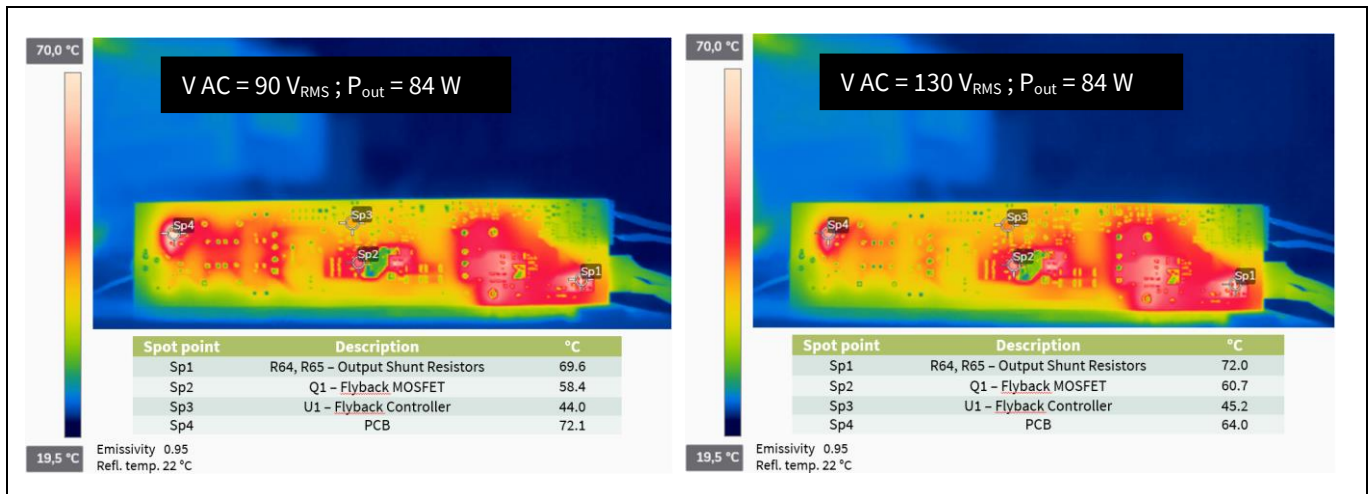

Figure 14 IR thermal image of PCB bottom components at low-line input

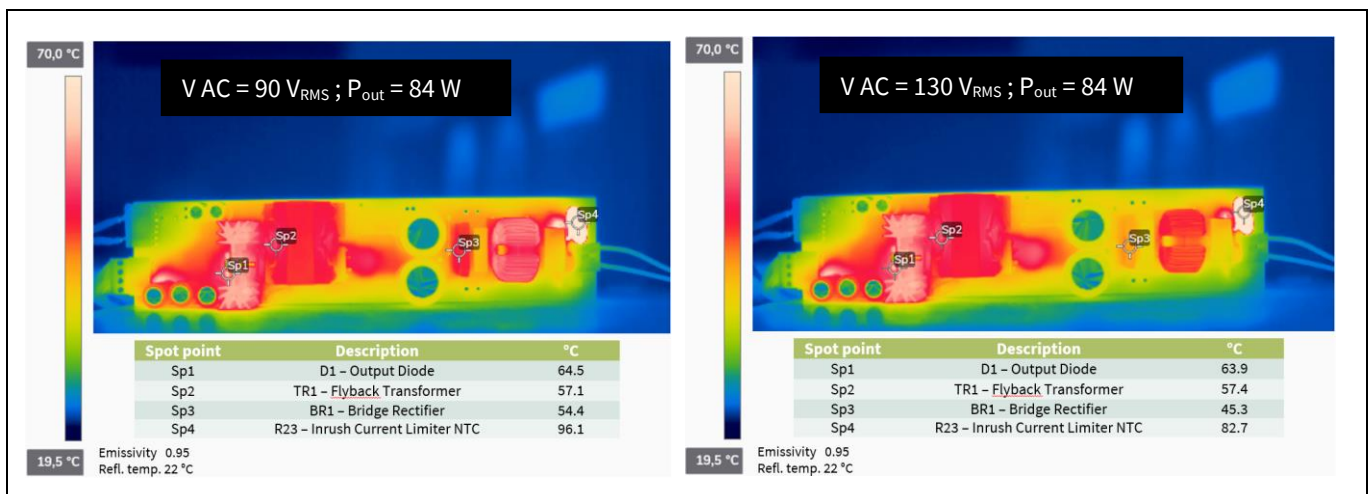

Figure 15 IR thermal image of PCB top components at low-line input

**Performance**

**5.5 Conducted emissions (EN 55022 class B)**

The conducted emissions test was performed at full output power (84 W), on both live and neutral based on EN 55022 standard class B limits, as shown in **Figure 16**, **Figure 17**, **Figure 18** and **Figure 19**.

The measurement equipment used for this conducted emissions test was Rohde & Schwarz HM6050-2 and Tektronix RSA503A.

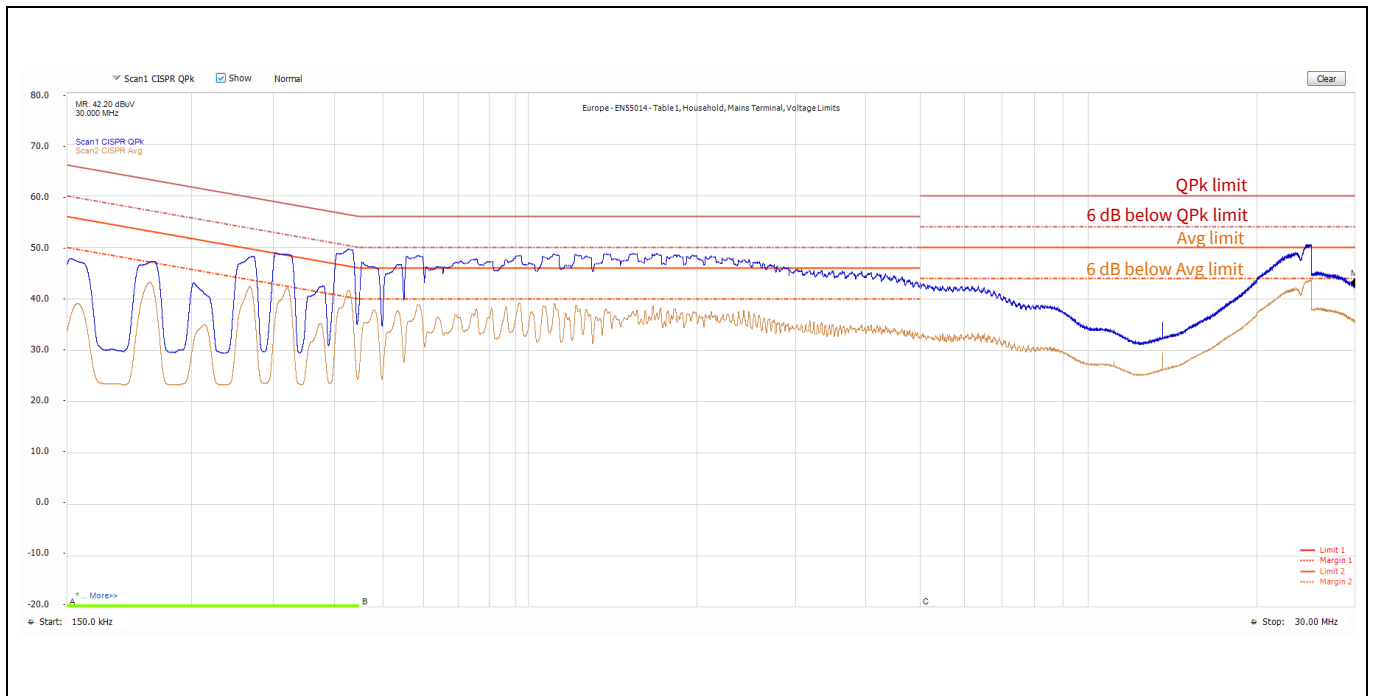

**Figure 16 Conducted emissions (live) test result at  $V_{AC} = 110 V_{RMS}$ ,  $F_{line} = 50 Hz$ ,  $P_{out} = 84 W$**

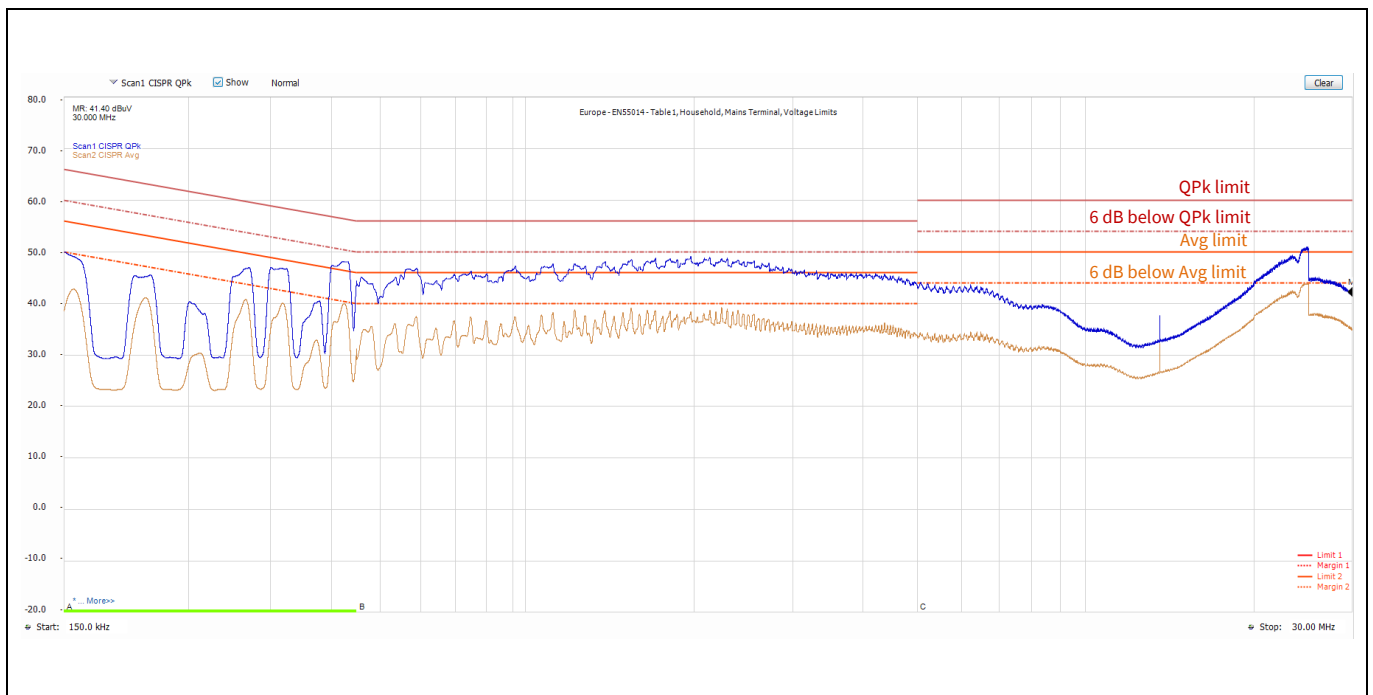

**Figure 17 Conducted emissions (neutral) test result at  $V_{AC} = 110 V_{RMS}$ ,  $F_{line} = 50 Hz$ ,  $P_{out} = 84 W$**

Performance

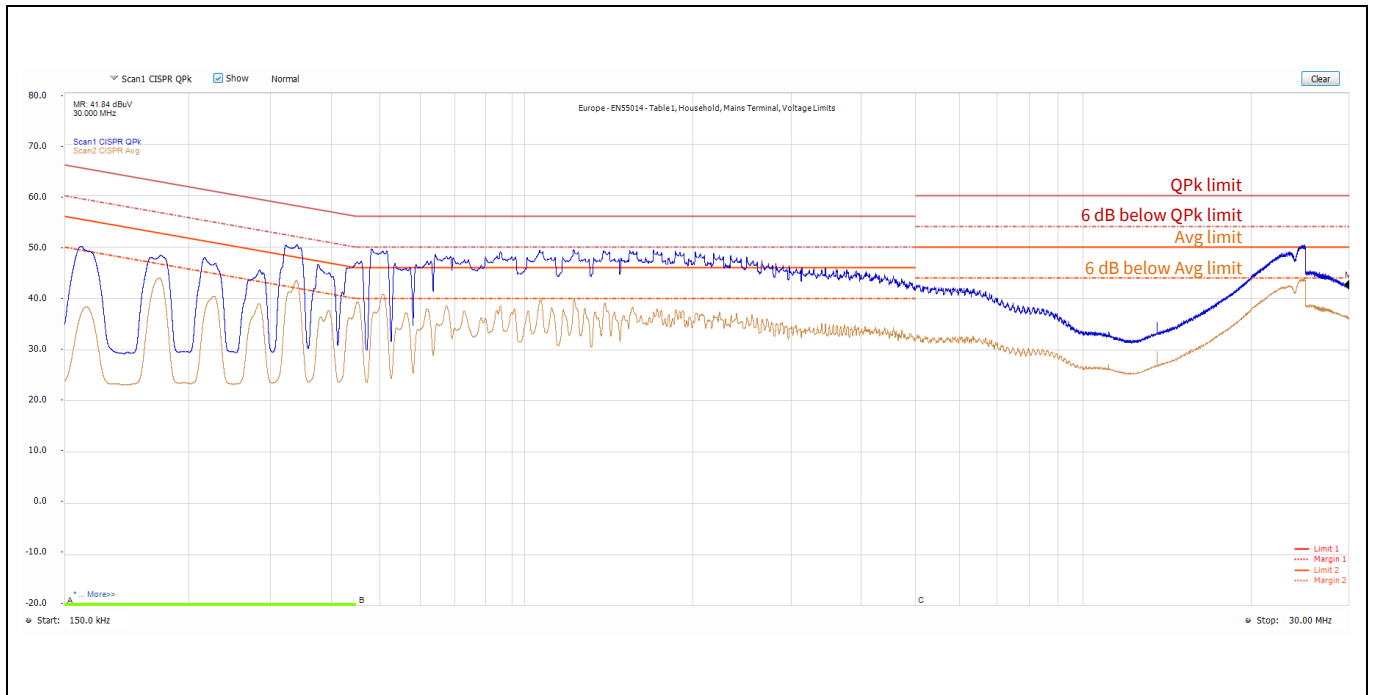

Figure 18 Conducted emissions (live) test result at  $V_{AC} = 230 V_{RMS}$ ,  $F_{line} = 50 Hz$ ,  $P_{out} = 84 W$

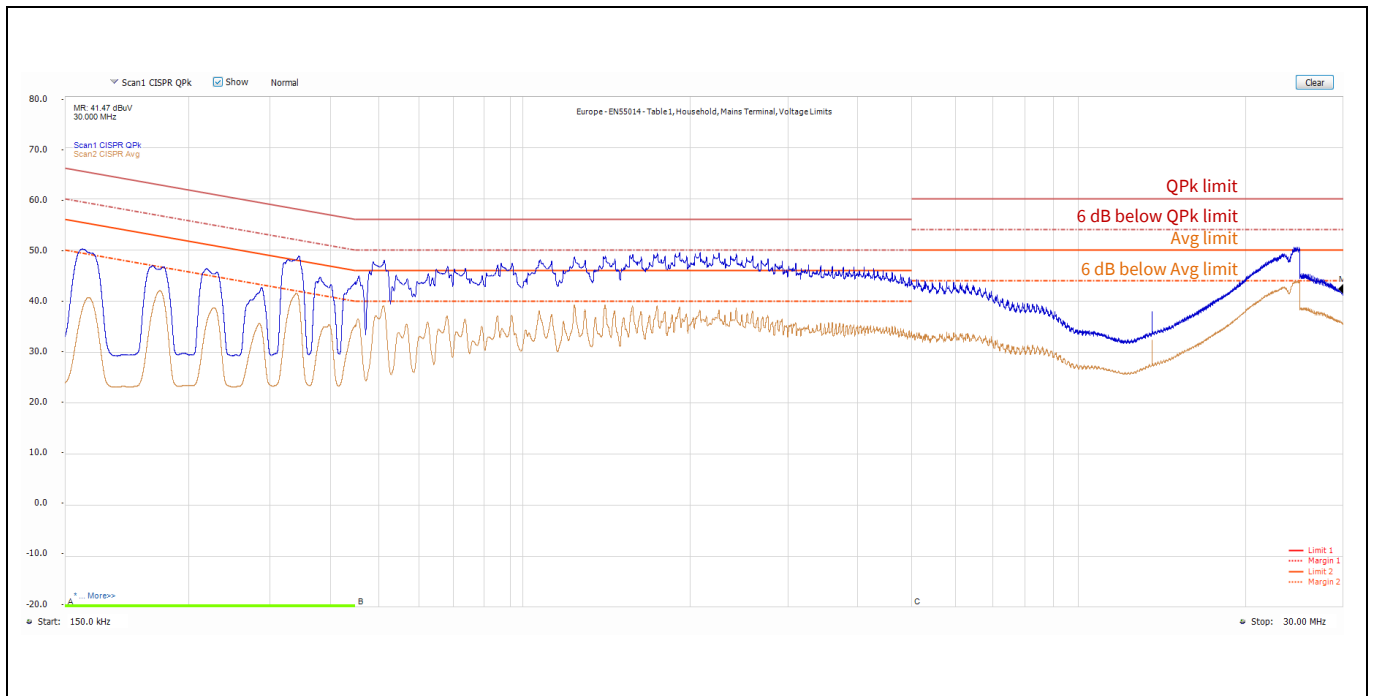

Figure 19 Conducted emissions (neutral) test result at  $V_{AC} = 230 V_{RMS}$ ,  $F_{line} = 50 Hz$ ,  $P_{out} = 84 W$



## 6 Bill of materials and transformer specifications

This section provides the bill of materials (BOM) and the transformer specifications.

### 6.1 BOM

**Table 6 BOM of the reference design board**

Designator	Description	Part number	Manufacturer
BR1	Diode GBU8K	GBU8K	ON Semiconductor
C1, C2	Capacitor 330 µF/200 V/THT/20%	200KXW330MEFC18X30	Rubycon
C3, C4, C5	Capacitor 560 µF/35 V/Radial leaded/20%	35ZLH560MEFC10X20	Rubycon
C6, C38	220 µF/35 V/THT	ECA1VAM221X	Panasonic
C7	Capacitor 1 nF/630 V/1206/C0G/5%	CGA5F4C0G2J102J085AA	TDK Corporation
C8	Capacitor 2.2 nF/630 V/1206/X7R/10%	CGA5H4X7R2J222K115AA	TDK
C9	Capacitor 1 µF/100 V/1206/X7R/10%	12061C105KAT2A	AVX
C10, C14	Capacitor 100 nF/100 V/3216 (1206)/10%	CGA5H2X8R2A104K115AA	TDK Corporation
C11	Capacitor 470 nF/THT/Radial/20%	B32922C3474M000	Epcos
C12	Capacitor 150 nF/310 V AC/Radial/10%	890334025022CS	Würth Elektronik
C16	10 µF/35 V/1206/	GMK316AB7106KL-TR	Taiyo Yuden
C19	Capacitor 2.2 µF/50 V/1206/X7R/10%	CGA5L3X7R1H225K160AB	TDK Corporation
C20	Capacitor 3.2 nF/THT 9.5 mm/20%	440LD32-R	Vishay
C22, C27	Capacitor 1 µF/50 V/0805/X7R/10%	GCM21BR71H105KA03	Murata
C23, C24, C29, C30, C32	Capacitor 100 nF/50 V/0603/X7R/10%	06035C104K4Z2A	AVX
C26	Capacitor 10 nF/50 V/0805/X7R/10%	08055C103K4Z2A	AVX
C28	Capacitor 100 pF/1 kV/1206/C0G/5%	GRM31A5C3A101JW01	Murata
C31	Capacitor 470 pF/50 V/0603/X8L/20%	CC0603KRX7R9BB471	Yageo
C33, C34	Capacitor 1 nF/50 V/0603/C0G/1%	C0603C102F5GAC	Kemet
C35	Capacitor 47 nF/25 V/0805/X7R/5%	GRM21BR71E473JA01	Murata
C36	Capacitor 10 nF/50 V/0603/X7R/10%	06035C103K4Z2A	AVX
C39, C40	47 µF/16 V/CAPC3225X270N/	GRM32EC81C476KE15K	Murata
D1	Diode V40100CI-M3/P/TO-220AB/	V40100CI-M3/P	Vishay
D2	Diode S2M/DO-214AA/	S2M	ON Semiconductor
D3	Diode PMEG150G20ELR/SOD-123W/	PMEG150G20ELR	Nexperia
D5	Diode BAV103/SOD-80C/	BAV103,115	Nexperia
D7	BAS416,115/SOD-323/	BAS416,115	Nexperia
D8	Diode 18 V/SOD-323 (SC-76)/	BZX384-C18,115	Nexperia
D9, D10	Diode BAV16WS-7-F/SOD-323/	BAV16WS-7-F	Diodes Inc.
F1	Fuse 300 V/3.15 A/300 V/	SS-5H-3.15A-APH	Bussmann (Eaton)
HS1	Heatsink/TO-220/34.92 mm L x 12.7 mm W x 25.4 mm H/	513002B02500G	Aavid Thermalloy
J5, J6	Connector/JP-THT-JL-600-25-T/	JL-600-25-T	Samtec
J1, J7, J8	Connector/JP-THT-JL-250-25-T/	JL-250-25-T	Samtec
J9	Connector/JP-THT-JL-500-25-T/	JL-500-25-T	Samtec
L3	Inductor 29 mH/THT/	SC22-025-290J	Kemet
MOV1	Varistor, 510 V/510 V/Radial type/10%	ERZE08A511	Panasonic
PC1	TLP383 (GR-TPL,E)/TLP383/	TLP383(GR-TPL,E)	Toshiba

# ICC80QSG 84 W AC-DC reference design #3 with IPN70R450P7S

For power tool battery charger with 110 V AC / 230 V AC rated input and constant current (CC) output up to 4 A



## Bill of materials and transformer specifications

Designator	Description	Part number	Manufacturer
Q1	Transistor IPN70R450P7S/PG-SOT-223-3/	IPN70R450P7S	Infineon Technologies
Q2	Transistor BC847C,215/45/SOT-23/	BC847C,215	Nexperia
R1, R2	Resistor 3 MEG/200 V/1206/1%	RC1206FR-073ML	Yageo
R3, R6, R27	Resistor 1 R/200 V/1206/1%	CRCW12061R00FK	Vishay
R4, R5	Resistor 1.5 R/1206/1%	ERJ8BQF1R5V	Panasonic
R7, R10, R13	Resistor 47 R/200 V/1206/1%	CRCW120647R0FKEAHP	Vishay
R9, R15, R18, R21	Resistor 82k/500 V/2512/1%	CRCW251282K0FK	Vishay
R11, R16, R24	Resistor 1.6 MEG/200 V/1206/1%	CRCW12061M60FK	Vishay
R14, R19	Resistor 620k/200 V/1206/1%	CRCW1206620KFK	Vishay
R17, R22	Resistor 75 R/200 V/1206/1%	CRCW120675R0FK	Vishay
R23	Resistor 3 R/THT/20%	B57238S0309M000	TDK Corporation
R28, R70, R72	Resistor 0 R/200 V/1206/0%	CRCW12060000Z0EA	Vishay
R34	Resistor 68k/75 V/0603/1%	CRCW060368K0FKEA	Vishay
R35, R37, R38	Resistor 1k/75 V/0603/1%	ERJ3EKF1001V	Panasonic
R36, R39	Resistor 4.99 MEG/200 V/1206/1%	CRCW12064M99FK	Vishay
R40, R49	Resistor 20k/50 V/0603/1%	MCR03EZPFX2002	ROHM Semiconductors
R41	Resistor 62k/150 V/805/1%	RC0805FR-0762KL	Yageo
R42	Resistor 47 R/200 V/1206/1%	CRCW120647R0FK	Vishay
R43	Resistor 22 R/150 V/0805/1%	CRCW080522R0FK	Vishay
R44	Resistor 10 R/75 V/0603/1%	RC0603FR-0710RL	Yageo
R45	Resistor 1.5k/75 V/0603/1%	RC0603FR-071K5L	Yageo
R46	Resistor 510k/200 V/1206/1%	CRCW1206510KFKEA	Vishay
R47	Resistor 10k/75 V/0603/1%	CRCW060310K0FK	Vishay
R48	Resistor 1.2MEG/150 V/0805/1%	CRCW08051M20FK	Vishay
R50	Resistor 30k/75 V/0603/1%	CRCW060330K0FK	Vishay
R51	Resistor 2.4k/200 V/1206/1%	CRCW12062K40FK	Vishay
R52	Resistor 56k/75 V/0603/1%	CRCW060356K0FK	Vishay
R53	Resistor 30k/75 V/0603/1%	CRCW060330K0FK	Vishay
R54	Resistor 4.7k/75 V/0603/1%	RC0603FR-074K7L	Yageo
R55	Resistor 330k/75 V/0603/1%	CRCW0603330KFK	Vishay
R56	Resistor 12k/50 V/0603/1%	RC0603FR-0712KL	Yageo
R57, R59	Resistor 0 R/75 V/0603/0 R	RC0603JR-070RL	Yageo
R60	Resistor 82k/75 V/0603/1%	CRCW060382K0FK	Vishay
R62	Resistor 15k/75 V/0603/1%	CRCW060315K0FK	Vishay
R63	Resistor 56k/75 V/0603/1%	CRCW060356K0FK	Vishay
R64, R65	Resistor 100 mR/1206/1%	ERJ8BWFR100V	Panasonic
TR1	Transformer 750845331/THT/	750845331	Würth Elektronik
U1	Int. ICC80QSG/PG-DSO-8-82/	ICC80QSG	Infineon Technologies
U2	Ana. TLV9102IDR/SOIC-8/	TLV9102IDR	Texas Instruments
U4	LDO IC/5 V/SOT-23/	MCP1799T-5002H/TT	Microchip Technology
X1	250-203/WAGO_250-203/	250-203	WAGO
Xout1	Connector/WR-TBL/	691322310004	Würth Elektronik
Xout2	Connector/THT 7 pin/2.54 mm pitch/	613007143121	Würth Elektronik

## 6.2 Transformer specifications

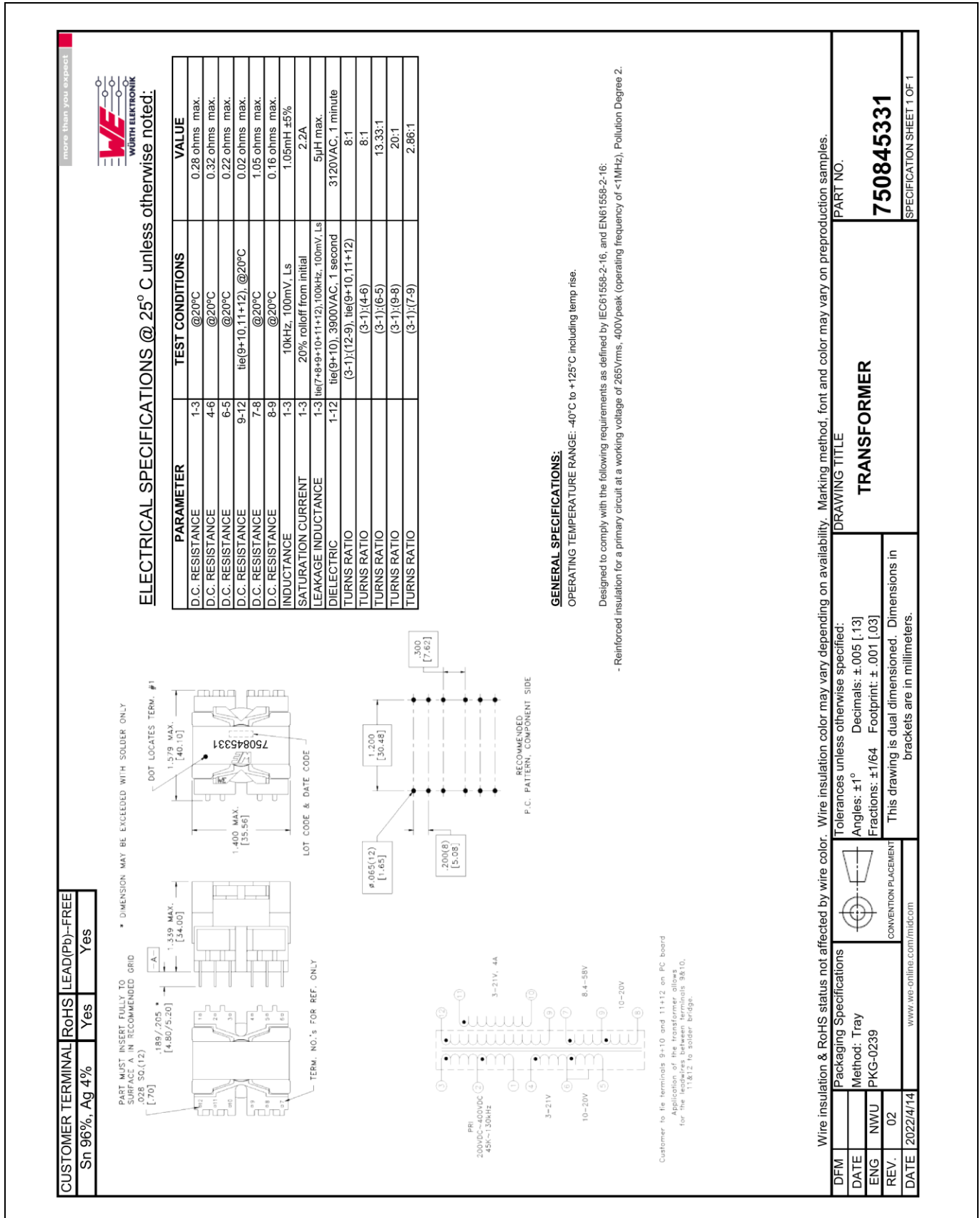

Figure 20 Flyback transformer (TR1) specifications

# ICC80QSG 84 W AC-DC reference design #3 with IPN70R450P7S

For power tool battery charger with 110 V AC / 230 V AC rated input and constant current (CC) output up to 4 A



## Revision history

### Revision history

Document version	Date of release	Description of changes
V 1.0	2023-06-23	Initial release

**Trademarks**

All referenced product or service names and trademarks are the property of their respective owners.

**Edition 2023-06-23**

**Published by**

**Infineon Technologies AG**

**81726 Munich, Germany**

**© 2023 Infineon Technologies AG.**

**All Rights Reserved.**

**Do you have a question about this document?**

**Email: [erratum@infineon.com](mailto:erratum@infineon.com)**

**Document reference**

**ER\_2211\_PL21\_2303\_111740**

**IMPORTANT NOTICE**

The information contained in this application note is given as a hint for the implementation of the product only and shall in no event be regarded as a description or warranty of a certain functionality, condition or quality of the product. Before implementation of the product, the recipient of this application note must verify any function and other technical information given herein in the real application. Infineon Technologies hereby disclaims any and all warranties and liabilities of any kind (including without limitation warranties of non-infringement of intellectual property rights of any third party) with respect to any and all information given in this application note.

The data contained in this document is exclusively intended for technically trained staff. It is the responsibility of customer's technical departments to evaluate the suitability of the product for the intended application and the completeness of the product information given in this document with respect to such application.

For further information on the product, technology, delivery terms and conditions and prices please contact your nearest Infineon Technologies office ([www.infineon.com](http://www.infineon.com)).

**WARNINGS**

Due to technical requirements products may contain dangerous substances. For information on the types in question please contact your nearest Infineon Technologies office.

Except as otherwise explicitly approved by Infineon Technologies in a written document signed by authorized representatives of Infineon Technologies, Infineon Technologies' products may not be used in any applications where a failure of the product or any consequences of the use thereof can reasonably be expected to result in personal injury.

## X-ON Electronics

Largest Supplier of Electrical and Electronic Components

*Click to view similar products for [Power Management IC Development Tools](#) category:*

*Click to view products by [Infineon](#) manufacturer:*

Other Similar products are found below :

[EVB-EP5348UI](#) [BQ25010EVM](#) [ISL80019AEVAL1Z](#) [ISLUSBI2CKIT1Z](#) [ISL8002AEVAL1Z](#) [ISL91108IIA-EVZ](#) [MAX8556EVKIT](#)  
[MAX15005AEVKIT+](#) [ISL28022EVKIT1Z](#) [STEVAL-ISA008V1](#) [DRI0043](#) [KITPF8100FRDMEVM](#) [EVB-EN6337QA](#)  
[SAMPLEBOXILD8150TOBO1](#) [MAX18066EVKIT#](#) [AP62300WU-EVM](#) [KITA2GTC387MOTORCTRTOBO1](#) [AEK-MOT-TK200G1](#)  
[EVLONE65W](#) [STEVAL-ILH006V1](#) [STEVAL-IPE008V2](#) [STEVAL-IPP001V2](#) [STEVAL-ISA013V1](#) [STEVAL-ISA067V1](#) [STEVAL-](#)  
[ISQ002V1](#) [TPS2306EVM-001](#) [TPS2330EVM-185](#) [TPS40001EVM-001](#) [SECO-HVDCDC1362-15W-GEVB](#) [BTS7030-2EPA](#)  
[LT8638SJV#WPBF](#) [LTC3308AIV#WTRPBF](#) [TLT807B0EPV](#) [BTS71033-6ESA](#) [EV13N91A](#) [EASYPIC V8 OVER USB-C](#) [EV55W64A](#)  
[CLICKER 4 FOR STM32F4](#) [EASYMX PRO V7A FOR STM32](#) [CLICKER 4 FOR PIC18F](#) [Si8285\\_86v2-KIT](#) [PAC52700EVK1](#) [NCP-](#)  
[NCV51752D2PAK3LGEVB](#) [ISL81807EVAL1Z](#) [AP33772S-EVB](#) [EVALM7HVIGBTFCINV4TOBO1](#) [903-0300-000](#) [902-0173-000](#) [903-](#)  
[0301-000](#) [ROA1286023/1](#)