



Product brief

ICL5102HV and ICL5102

PFC + resonant half-bridge controller

Simplify your design – reducing the number of ICs to one

The integrated two-stage combination controller (PFC + LLC/LCC) allows for reduced number of external components, while optimizing bill of materials (BOM) and form factor. In contrast to the conventional solutions with two ICs, the ICL5102HV not only simplifies your design with a single IC, but also shortens time-to-market. The configuration of ICL5102HV can be simply tailored through resistors.

Benefit from best performance of total harmonic distortion (THD) and power factor (PF)

THD optimization of ICL5102HV ensures low harmonic distortion (total harmonic distortion, THD) of less than 10 percent at 30 percent nominal load. PFC controller with both critical conduction mode (CrCM) and discontinuous conduction mode (DCM) delivers best PF that the industry recognizes. Thanks to Infineon's coreless transformer technology, half-bridge switching frequency could be up to 500 KHz without significant temperature increase. Driving both high- and low-side MOSFETs, non-overlap dead time is self-adaptive from 300-750 ns, hence, ensuring good EMI and efficiency. In addition, flickerless dimming is materialized across wide range of the load.

Enable universal AC input voltage 90-480 V

Helping your products address global market with less product variants, DSO-19 package of ICL5102HV enables the capability of handling 980 V between high-side ground and ground.

Safety first

The controller has a comprehensive set of protection features built-in to increase the system safety. In the run mode, it monitors the complete system regarding to bus over- and undervoltage, open loop, overcurrent of PFC and/or inverter, output overvoltage, overtemperature and capacitive load regulation.

Key features

- > Resonant half-bridge (HB) controller with fixed or variable switching frequency control
- > Maximum 500 kHz HB switching frequency and soft-start frequency up to 1.3 MHz
- > Resonant HB burst mode (BM) ensures power limitation and low standby power < 300 mW
- > Excellent system efficiency up to 94%
- > High-side MOSFET driver with coreless transformer
- > Input brown-out protection
- > PFC bus overvoltage protection
- > PFC overcurrent protection
- > Output overvoltage protection
- > Output overcurrent/short circuit protection
- > Output overpower/overload protection
- > Capacitive mode protection
- > External overtemperature protection



ICL5102HV and ICL5102

PFC + resonant half-bridge controller

ICL5102/ICL5102HV typical application with PFC+LCC topology

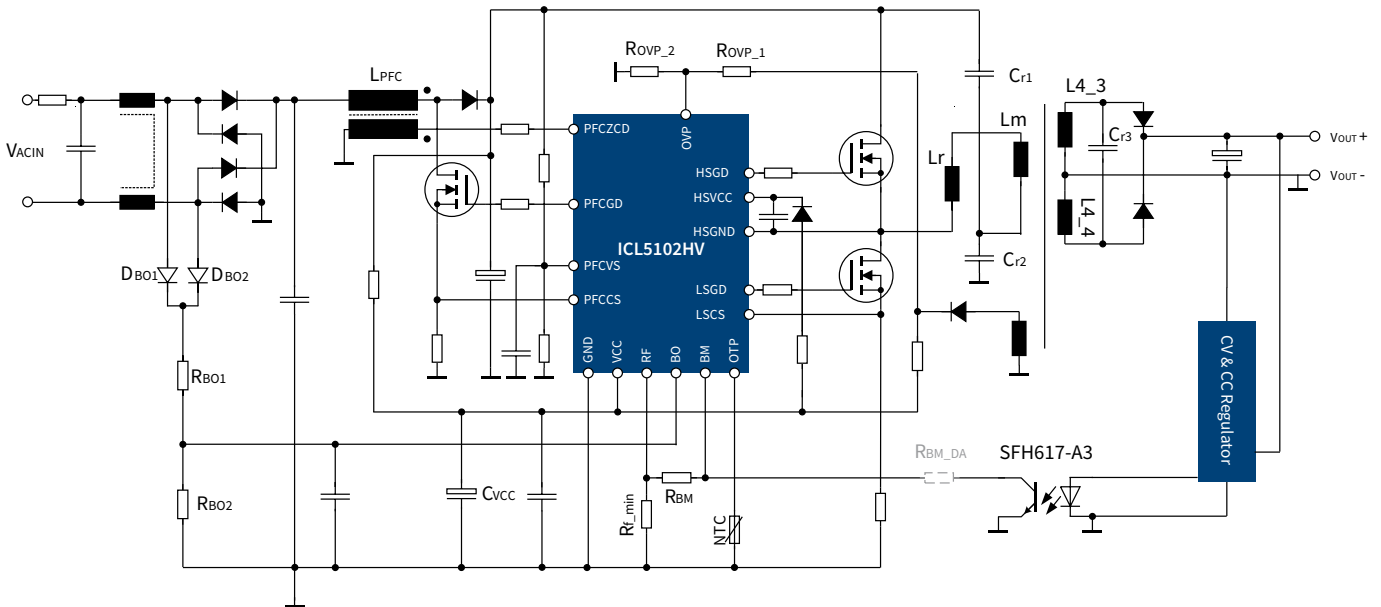

Product portfolio

Order code	Package	Packing	Description
ICL5102HVXUMA1	PG-DSO-19-5	Tape and reel	980 V high-side ground combo, PFC + LLC/LCC
ICL5102HXUMA2	PG-DSO-16-23	Tape and reel	Combo IC: PFC + LLC/LCC

Published by
Infineon Technologies Austria AG
9500 Villach, Austria

© 2019 Infineon Technologies AG.
All Rights Reserved.

Please note!

THIS DOCUMENT IS FOR INFORMATION PURPOSES ONLY AND ANY INFORMATION GIVEN HEREIN SHALL IN NO EVENT BE REGARDED AS A WARRANTY, GUARANTEE OR DESCRIPTION OF ANY FUNCTIONALITY, CONDITIONS AND/OR QUALITY OF OUR PRODUCTS OR ANY SUITABILITY FOR A PARTICULAR PURPOSE. WITH REGARD TO THE TECHNICAL SPECIFICATIONS OF OUR PRODUCTS, WE KINDLY ASK YOU TO REFER TO THE RELEVANT PRODUCT DATA SHEETS PROVIDED BY US. OUR CUSTOMERS AND THEIR TECHNICAL DEPARTMENTS ARE REQUIRED TO EVALUATE THE SUITABILITY OF OUR PRODUCTS FOR THE INTENDED APPLICATION.

WE RESERVE THE RIGHT TO CHANGE THIS DOCUMENT AND/OR THE INFORMATION GIVEN HEREIN AT ANY TIME.

Additional information

For further information on technologies, our products, the application of our products, delivery terms and conditions and/or prices, please contact your nearest Infineon Technologies office (www.infineon.com).

Warnings

Due to technical requirements, our products may contain dangerous substances. For information on the types in question, please contact your nearest Infineon Technologies office.

Except as otherwise explicitly approved by us in a written document signed by authorized representatives of Infineon Technologies, our products may not be used in any life-endangering applications, including but not limited to medical, nuclear, military, life-critical or any other applications where a failure of the product or any consequences of the use thereof can result in personal injury.

X-ON Electronics

Largest Supplier of Electrical and Electronic Components

Click to view similar products for [LED Lighting Development Tools](#) category:

Click to view products by [Infineon](#) manufacturer:

Other Similar products are found below :

[MIC2870YFT EV](#) [TDGL014](#) [ISL97682IRTZEVALZ](#) [EA6358NH](#) [TPS92315EVM-516](#) [STEVAL-LLL006V1](#) [IS31LT3948-GRLS4-EB](#)
[PIM526](#) [PIM527](#) [MAX6946EVKIT+](#) [MAX20070EVKIT#](#) [MAX20090BEVKIT#](#) [PIM498](#) [AP8800EV1](#) [ZXLD1370/1EV4](#) [1216.1013](#) [1270](#)
[1271.2004](#) [1272.1030](#) [1273.1010](#) [1278.1010](#) [1279.1002](#) [1279.1001](#) [1282.1000](#) [1293.1900](#) [1293.1800](#) [1293.1700](#) [1293.1500](#) [1293.1100](#)
[1282.1400](#) [1282.1100](#) [1293.1200](#) [1282.1200](#) [1293.1000](#) [1282.6000](#) [1296.2012](#) [MIKROE-2520](#) [1721](#) [1762](#) [PIR-GEVB](#) [TPS61161EVM-243](#)
[STEVAL-ILL056V1](#) [ADM00767](#) [STEVAL-ILL080V1](#) [DC1224A](#) [DC1160A](#) [DC1039A-A](#) [DC1816B](#) [DC1511A-A](#) [DC1274A](#)