

ICL8810 116 W AC-DC reference design with IPD80R280P7

For battery charger with 115 V AC to 230 V AC nominal input and 30 V to 58 V constant current (CC) output up to 2 A load current

ER_2308_PL21_2309_093427



About this document

Scope and purpose

This document is an engineering report for the 116 W AC-DC converter reference design (orderable part number: REF_ICL8810_116W_BPA), which uses Infineon's [ICL8810 flyback controller](#) and [IPD80R280P7 MOSFET](#).

This reference design board can be used for battery charging applications by adding both the battery safety switch and the charging profile control circuits externally. See the test setup and safety information section of this document for more information.

Intended audience

This document is intended for power supply design engineers, application engineers, and users of the 116 W AC-DC reference design board.

Table of contents

Table of contents

About this document..... 1

Table of contents..... 2

1 Test setup and safety information..... 3

2 Design features 5

3 Board specifications 6

4 Schematic and PCB layout..... 8

5 Performance.....10

5.1 Efficiency..... 10

5.2 Standby power 13

5.3 PFC performance..... 14

5.4 Brown-in and brown-out protection 15

5.5 Thermal test 16

5.6 Conducted emissions (EN 55022 class B) 17

6 Bill of materials and transformer specifications18

6.1 BOM..... 18

6.2 Transformer specifications 21

Revision history.....23

Disclaimer.....24

Test setup and safety information

1 Test setup and safety information

This AC-DC reference design is a flyback converter with secondary-side regulated (SSR) constant current (CC) output. The CC output set-point is adjustable with a 0 to 3 V analog input signal.

As shown in Figure 1, to use this reference design board for battery charging application testing, you must add both the battery safety switch and the charging profile control circuits externally, which work according to the board and battery specification.

Attention: For safety reasons, it is prohibited to connect this reference design board to any battery without adding the battery safety switch and charging profile control circuits externally.

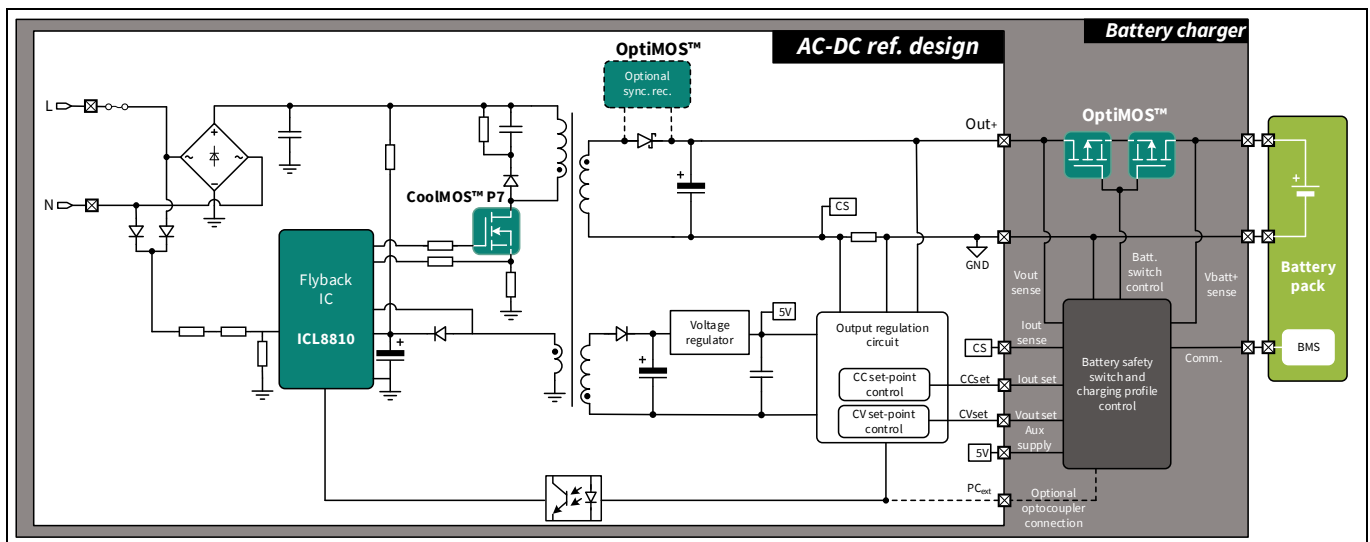

Figure 1 Test setup of AC-DC reference design with connections to external battery safety switch and charging profile control circuits, for battery charging application testing

Alternatively, a test setup using the electronic load (in constant voltage/CV mode) and DC source (for adjusting the CC set point) can be done based on Figure 2.



Figure 2 Test setup with electronic load and adjustable CC set point using DC source

Attention: Dangerous voltages are present on this reference design. Do not operate the board unless you are trained to handle high-voltage (HV) circuits. Do not leave this board unattended when it is powered up.

ICL8810 116 W AC-DC reference design with IPD80R280P7

Test setup and safety information

For EMI testing with full output power of 116 W, the test setup in [Figure 3](#) is recommended.



Figure 3 EMI test setup with full output power

For no-load system standby power measurement, the test setup in [Figure 4](#) is recommended.



Figure 4 No-load system standby power test setup

Design features

2 Design features

- Secondary-side regulation (SSR), with adjustable constant current (CC) output set-point from 0 to 2 A
- Supports wide output load range from 24 to 58 V (see [Board specifications](#) for details)
- High efficiency and low EMI with quasi-resonant (QR) valley switching
- Cost-effective flyback MOSFET with high performance, using [CoolMOS™ P7 in SOT-223 package](#)
- Full power efficiency more than 91 percent at 230 V_{RMS} AC input
- Four-point average efficiency more than 89 percent at high-line input voltage range and full power output
- Burst mode with reduced gate driver output voltage for lower standby power
- System standby power less than 300 mW for whole input voltage and range
- Power factor more than 0.9 for the whole input voltage range and full power output
- Harmonic current emissions under the limits specified by IEC 61000-3-2 Class A
- Adaptive brown-out level triggering based on bus voltage ripple to better protect primary components from overheating and saturation with higher brown-out level at higher power transfer
- Comprehensive set of protections: internal overtemperature protection (OTP), output overvoltage protection (OVP), V_{CC} OVP, primary-side overcurrent protection (OCP), brown-in and brown-out protection
- Soft-start to reduce component stress during turn-on

Board specifications

3 Board specifications

Table 1 lists the electrical specifications of the evaluation board.

Table 1 Electrical specifications

Specification	Symbol	Value	Unit
Normal operational AC input voltage	V_{AC}	90 to 264	VRMS
Normal operational AC input frequency	F_{line}	47 to 63	Hz
CC output set-point	$I_{out,setpoint}$	0 to 2.0	A
CC output set-point control voltage (see Figure 5 for details)	CC_{set}	0 to 3	V
Output load range ($I_{out,setpoint} = 0$ to 4 A)	$V_{load,CV}$	24 to 58	V
Input power under no-load condition ($V_{AC} = 230 V_{RMS}$; $F_{line} = 50$ Hz; output open)	$P_{in,no-load}$	< 240	mW
Input power under no-load condition ($V_{AC} = 115 V_{RMS}$; $F_{line} = 50$ Hz; output open)	$P_{in,no-load}$	< 100	mW
Steady-state output voltage limit under no-load condition	$V_{out,FB,limit}$	64	V
Efficiency at full output power ($V_{AC} = 230 V_{RMS}$; output voltage = 58 V; $I_{out,setpoint} = 2.0$ A)	η	91.2	%
Efficiency at full output power ($V_{AC} = 115 V_{RMS}$; output voltage = 58 V; $I_{out,setpoint} = 2.0$ A)	η	89.1	%
Four-point average efficiency – high-line low ($V_{AC} = 176 V_{RMS}$; output voltage = 58 V; $I_{out} = 0.5$ A, 1 A, 1.5 A, and 2 A)	$\eta_{avg,4-point1}$	88.9	%
Four-point average efficiency – high-line high ($V_{AC} = 264 V_{RMS}$; output voltage = 58 V; $I_{out} = 0.5$ A, 1 A, 1.5 A, and 2 A)	$\eta_{avg,4-point2}$	89.0	%
Four-point average efficiency – low-line low ($V_{AC} = 90 V_{RMS}$; output voltage = 58 V; $I_{out} = 0.5$ A, 1 A, 1.5 A, and 2 A)	$\eta_{avg,4-point1}$	87.6	%
Four-point average efficiency – low-line high ($V_{AC} = 130 V_{RMS}$; output voltage = 58 V; $I_{out} = 0.5$ A, 1 A, 1.5 A, and 2 A)	$\eta_{avg,4-point2}$	89.0	%

Board specifications

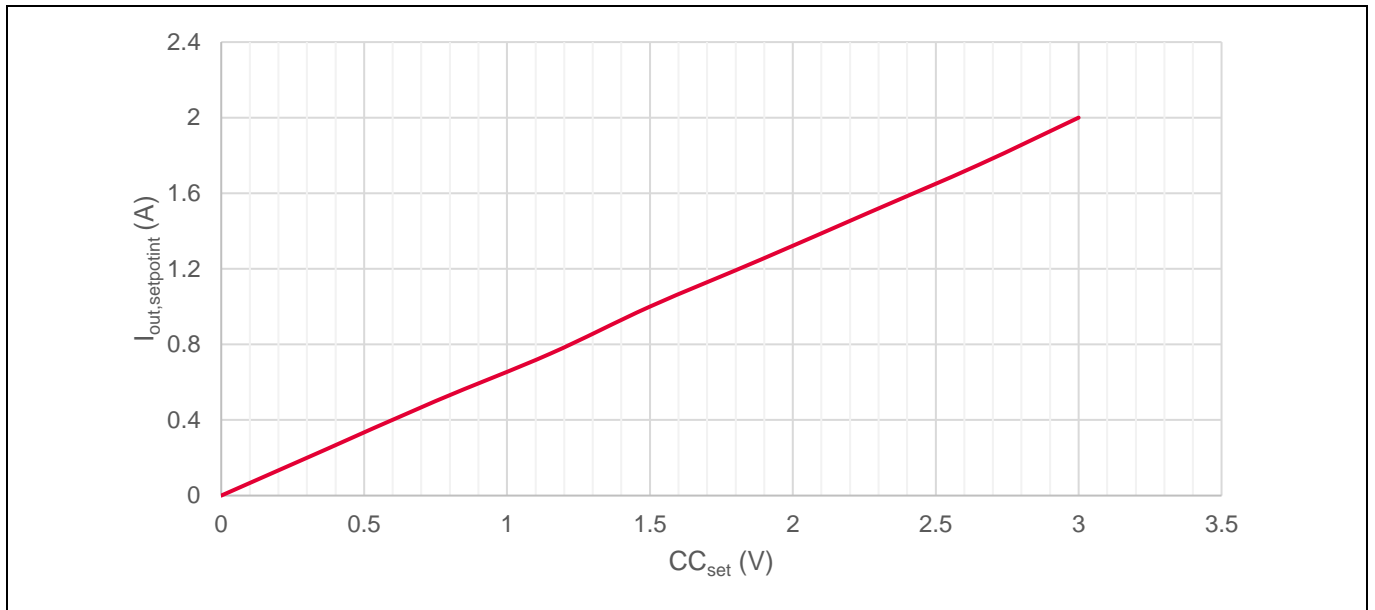

Figure 5 $I_{out,setpoint}$ control based on CC_{set} input signal

Schematic and PCB layout

4 Schematic and PCB layout

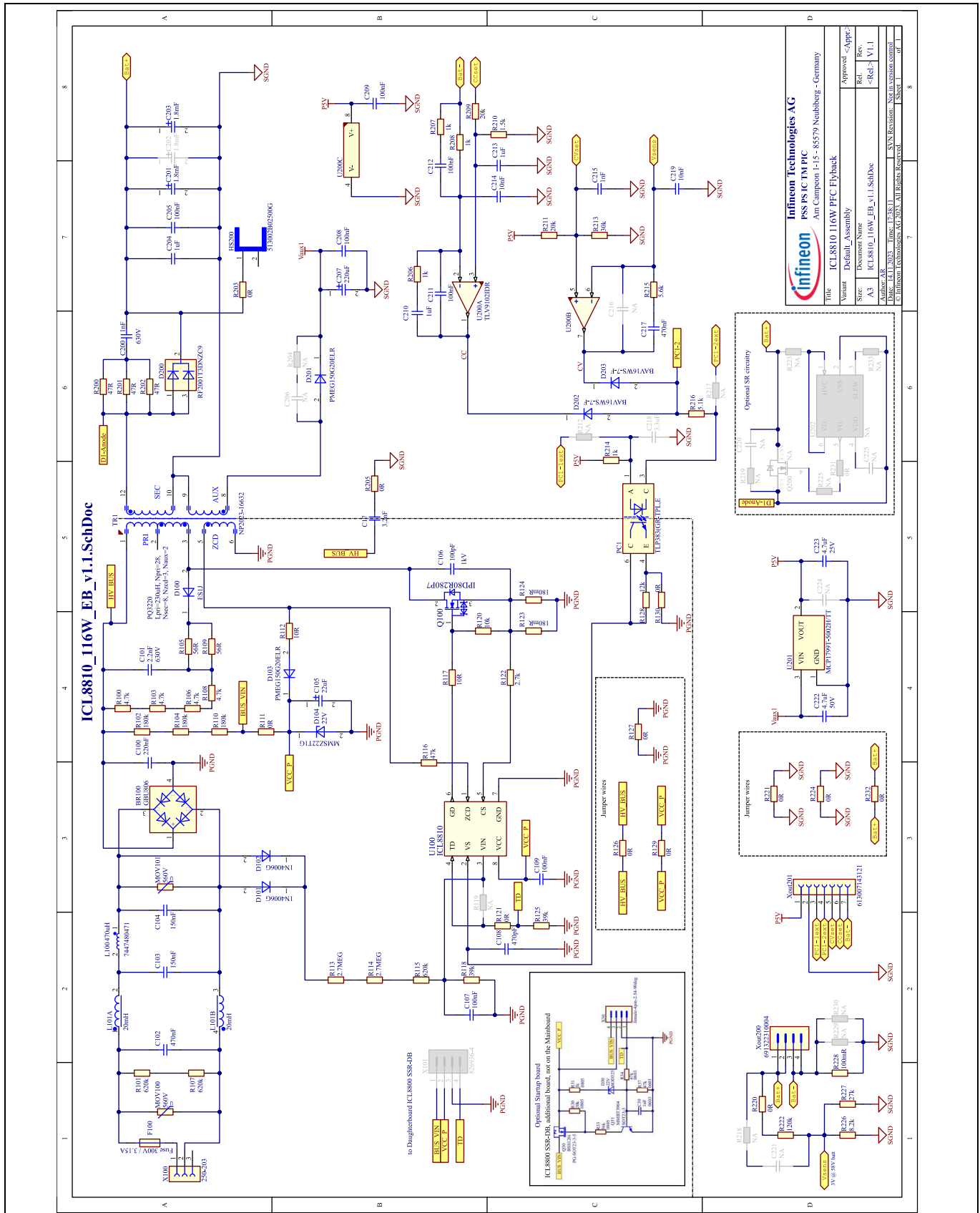

Figure 6 Reference design board schematic

Schematic and PCB layout

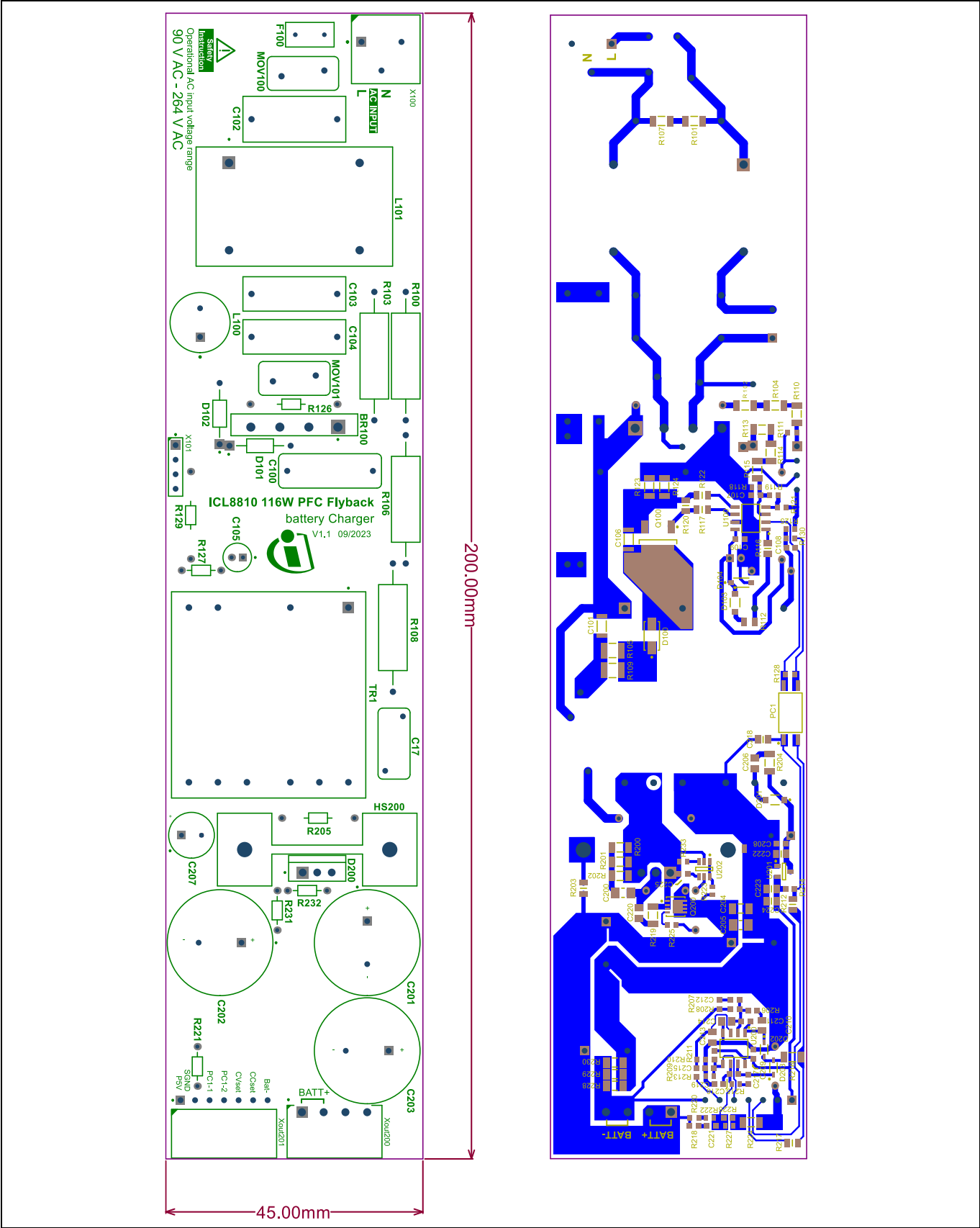

Figure 7 PCB top (left) and bottom (right) layout of the reference design board

Performance

5 Performance

The results shown in this section are based on the evaluation of a single board at room temperature.

5.1 Efficiency

The efficiency at 36 V output voltage with 2 A output current setting (CC set adjusted to 3 V) is measured at more than 90.3 percent at typical input voltage of 230 V_{RMS} and more than 88 percent across the whole low-line input voltage range, as shown in [Figure 8](#).

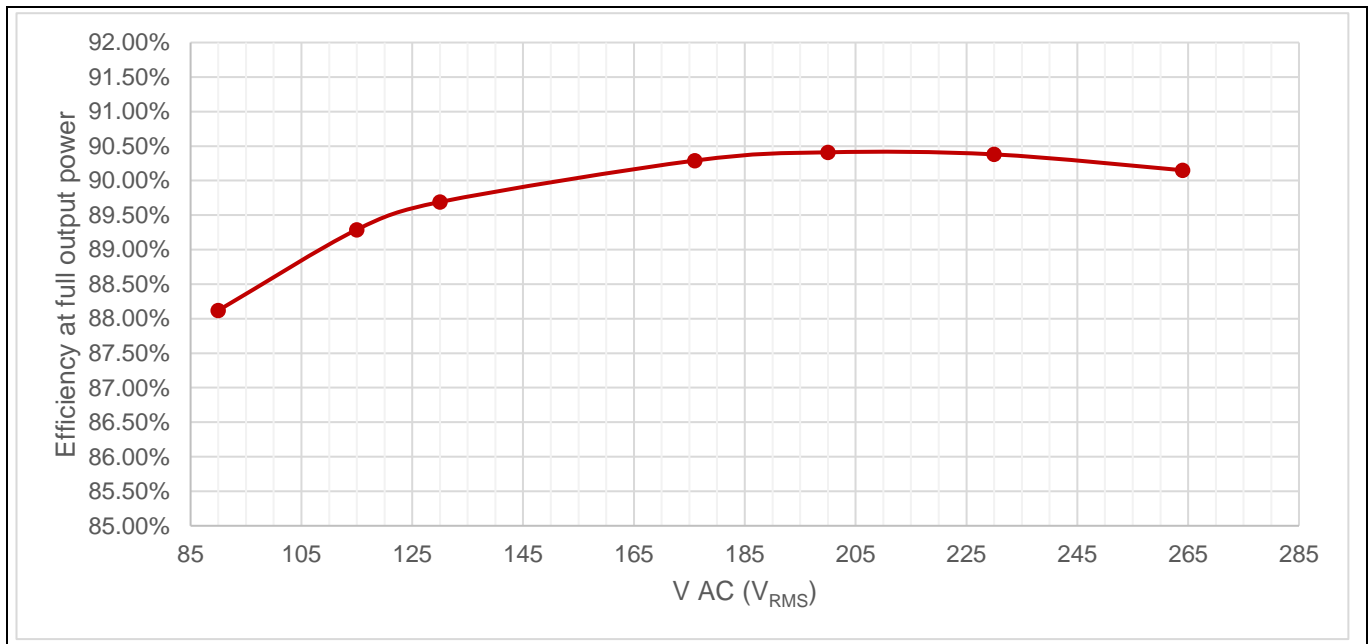

Figure 8 Efficiency versus input voltage at 36 V and 2 A output (72 W)

For high-line input voltage range, the efficiency at full output power (116 W) is more than 90.8 percent and 91.2 percent at typical V AC of 230 V_{RMS}, as shown in [Figure 9](#).

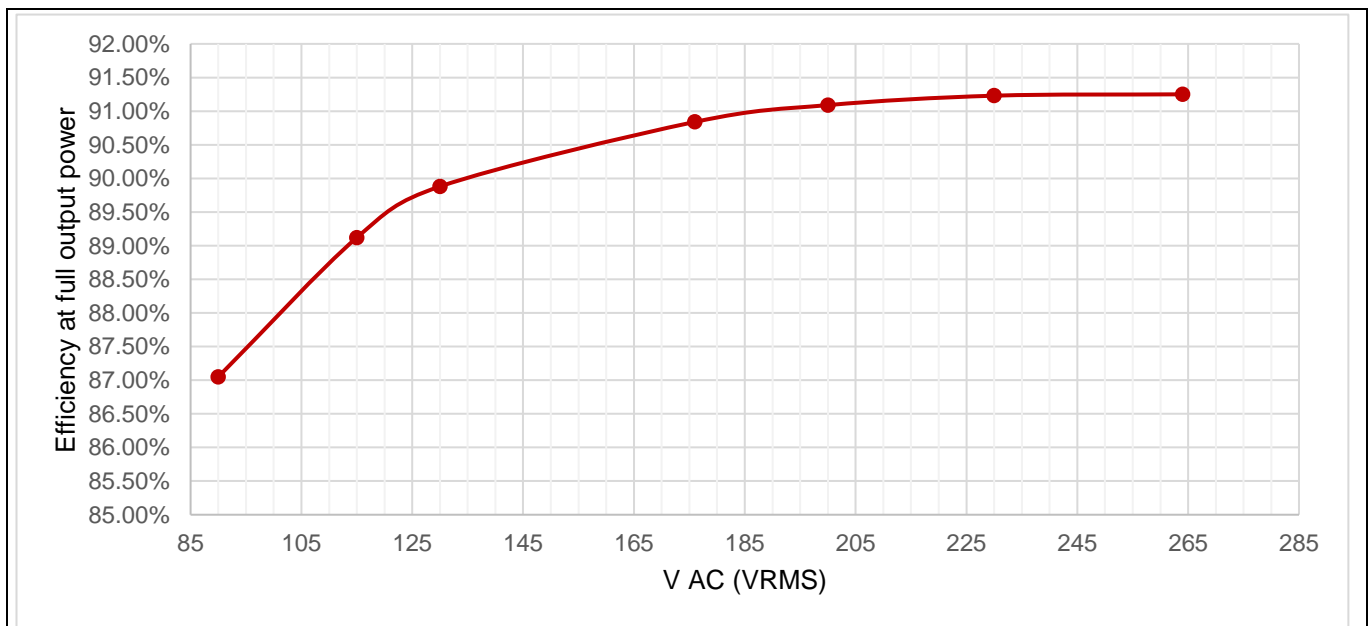

Figure 9 Efficiency versus input voltage at 58 V and 2 A output (116 W)

Performance

The four-point average efficiency for 58 V output voltage for input voltage corner-cases is presented in [Table 2](#). The measurement reveals an average efficiency value of more than 89 percent at minimum and maximum of high-line input voltage. The same measurement performed at low-line input voltage range indicates an average efficiency value of more than 87.5 percent.

Table 2 Four-point average efficiency at 58 V output voltage in input voltage corner-cases

V AC (V _{RMS})	Output load (V)	I _{out,setpoint} (mA)	I _{out,setpoint} (%)	Efficiency (%)	Four-point average efficiency (%)
176	58	2000	100	90.83	89.32
		1500	75	90.76	
		1000	50	89.77	
		500	25	85.93	
264	58	2000	100	91.25	89.00
		1500	75	90.69	
		1000	50	89.22	
		500	25	84.82	
90	58	2000	100	87.04	87.64
		1500	75	88.49	
		1000	50	88.71	
		500	25	86.31	
130	58	2000	100	89.91	89.00
		1500	75	90.19	
		1000	50	89.69	
		500	25	86.22	

For an output voltage of 36 V, the four-point average efficiency is measured at more than 88 percent for the input voltage corner cases as shown in [Table 3](#).

Performance
Table 3 Four-point average efficiency at 36 V output voltage in input voltage corner-cases

V AC (V_{RMS})	Output load (V)	I_{out,setpoint} (mA)	I_{out,setpoint} (%)	Efficiency (%)	Four-point average efficiency (%)
176	36	2000	100	90.31	88.96
		1500	75	90.28	
		1000	50	89.34	
		500	25	85.92	
264	36	2000	100	90.22	88.01
		1500	75	89.57	
		1000	50	88.28	
		500	25	83.95	
90	36	2000	100	88.12	88.23
		1500	75	88.84	
		1000	50	89.01	
		500	25	86.93	
130	36	2000	100	89.69	88.90
		1500	75	90.02	
		1000	50	89.64	
		500	25	86.26	

Performance

5.2 Standby power

Under no-load conditions, the input power measurement indicates a value under 120 mW at the low-line input voltage range and 300 mW at the high-line input voltage range, as shown in [Figure 10](#) and [Figure 11](#).

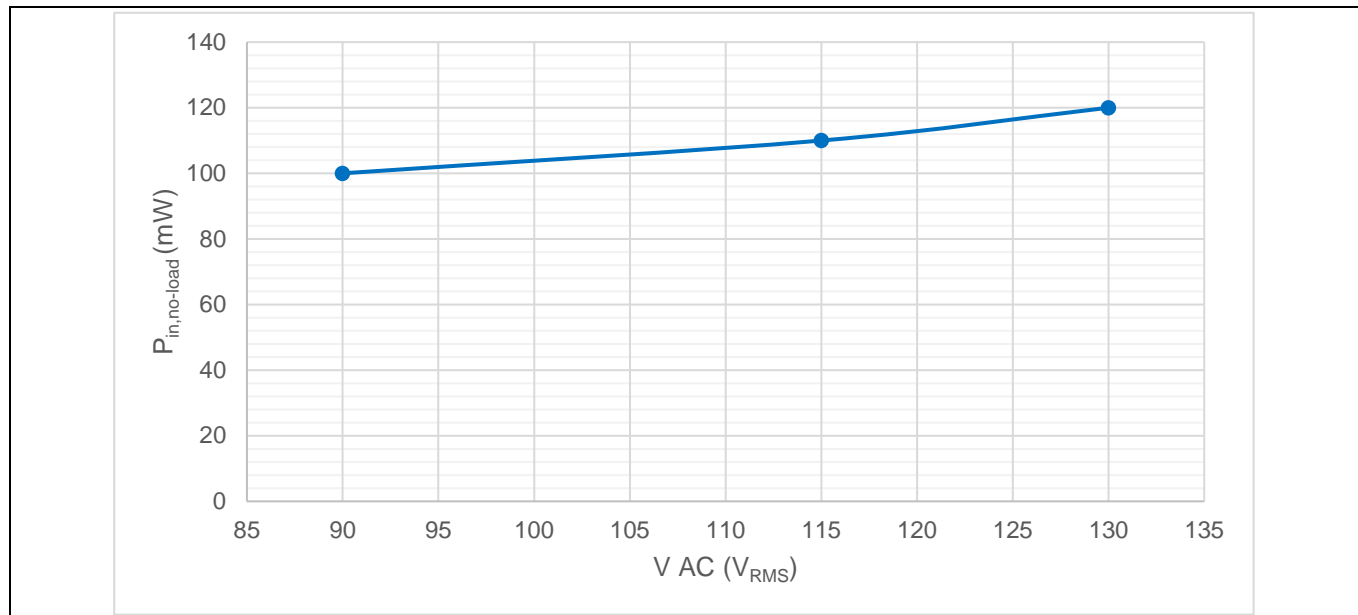

Figure 10 Input power under no-load condition at low-line input

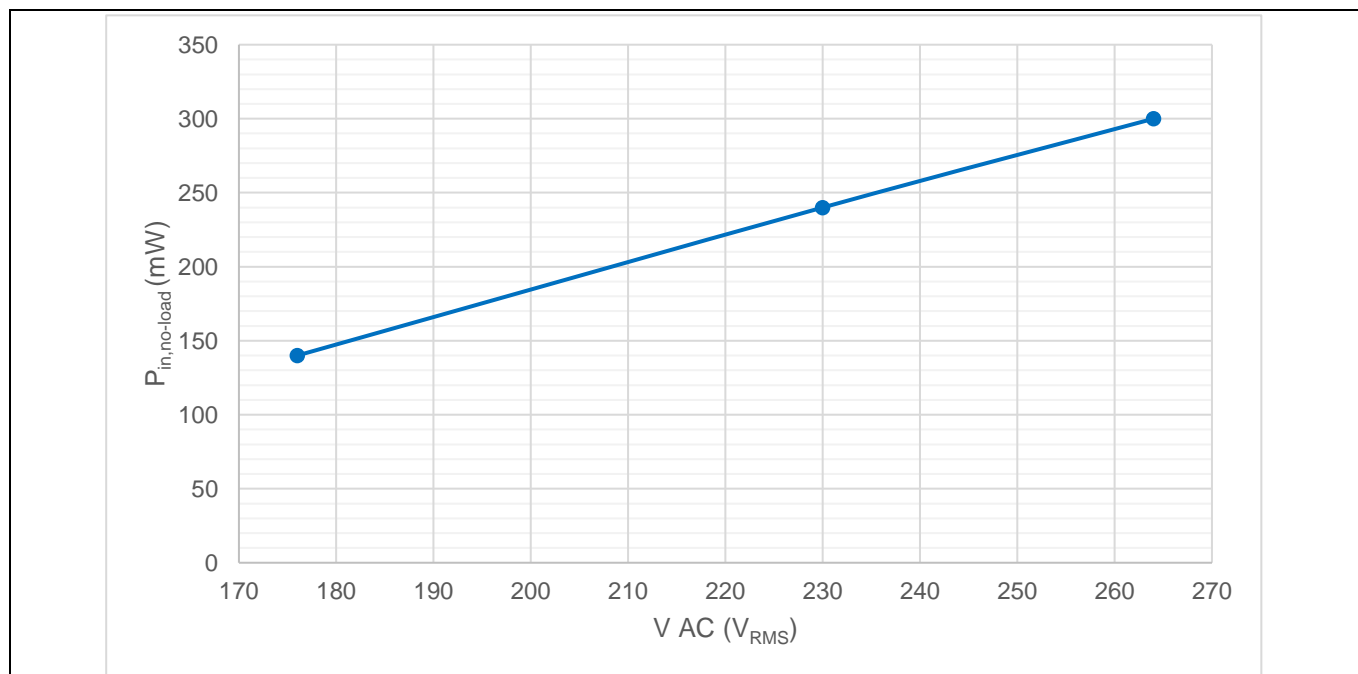

Figure 11 Input power under no-load condition at high-line input

Performance

5.3 PFC performance

Table 4 shows the PFC performance at 58 V and 36 V output voltages at 115 V AC and 230 V AC input voltages. In all conditions the output current is set at 2 A. High power factor is achieved as shown in the measurement.

Table 4 Power factor measurement

Output voltage (V)	V AC (V)	115	230
	36		0.98
58		0.98	0.94

As shown in Figure 12, the measured harmonic currents are low to comply with IEC 61000-3-2 Class A.

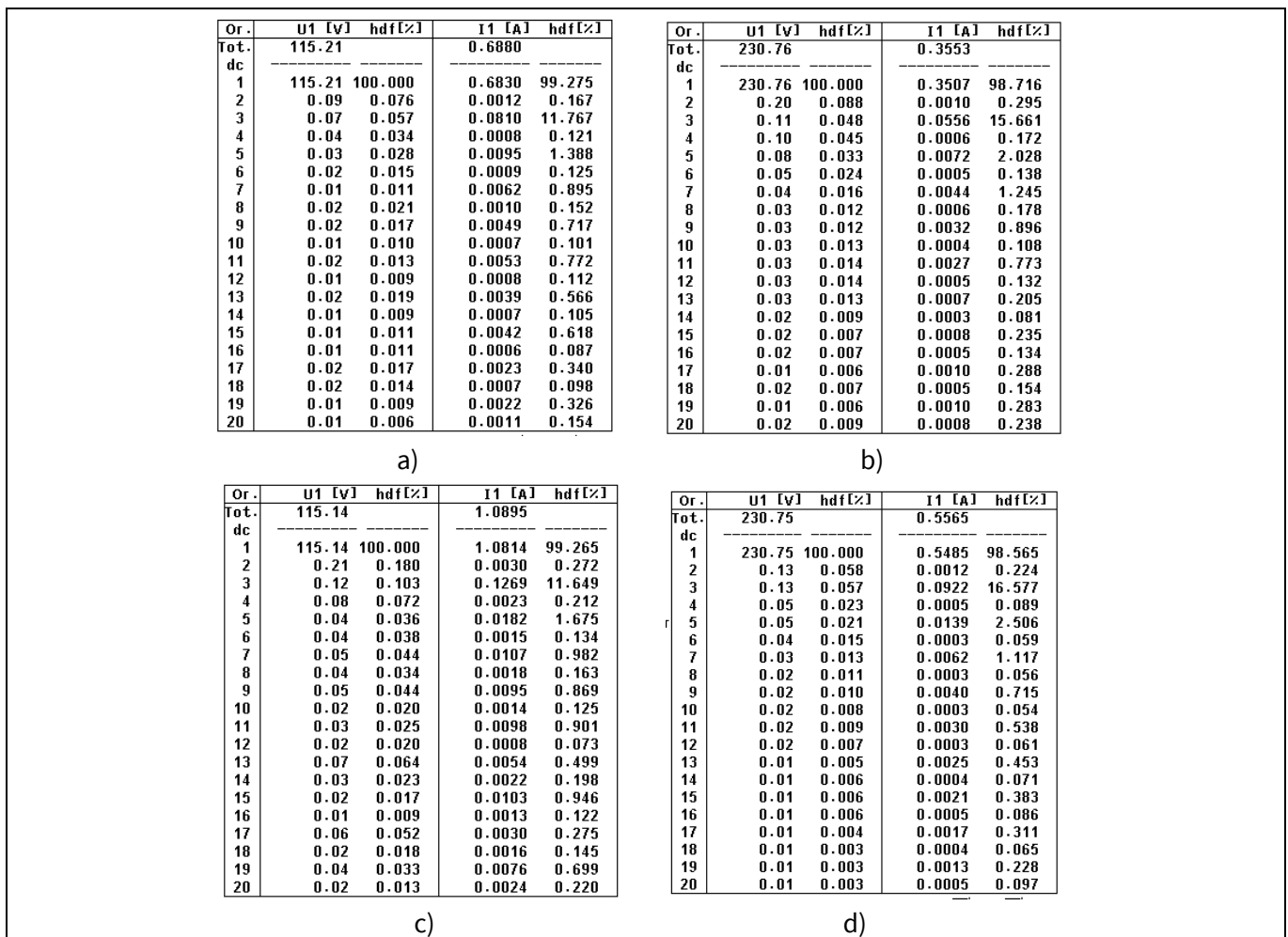

Figure 12 Harmonics current measurements: a) 115 V AC, 36 V output, b) 230 V AC, 36 V output, c) 115 V AC, 58 V output, and d) 230 V AC, 58 V output

Performance

5.4 Brown-in and brown-out protection

ICL8810 features an adaptive brown-out level triggering based on bus voltage ripple.

As shown in [Table 5](#) and [Table 6](#), with these features, this reference design demonstrates a higher brown-out level at higher power transfer, while still ensuring sufficient hysteresis between brown-in and brown-out. As a result, ICL8810 can better protect the primary components from overheating and saturation when an input undervoltage condition occurs.

Table 5 Brown-in test result

F_{line} (Hz)	Output voltage (V)	I_{out,setpoint} (mA)	I_{out,setpoint} (%)	Brown-in V AC (V_{RMS})
50	58	0	0	89.8
		1000	50	89.9
	36	0	0	89.8
		1000	50	90.1

Table 6 Brown-out test result

F_{line} (Hz)	Output load (V)	I_{out,setpoint} (mA)	I_{out,setpoint} (%)	Brown-out V AC (V_{RMS})
50	58	0	0	64.5
		1000	50	65.1
	36	0	0	64.1
		1000	50	64.9

Performance

5.5 Thermal test

The open-frame thermal measurement is done after one hour of operation with full output power (116 W) using an infrared (IR) thermography camera. The ambient temperature is approximately 22°C.

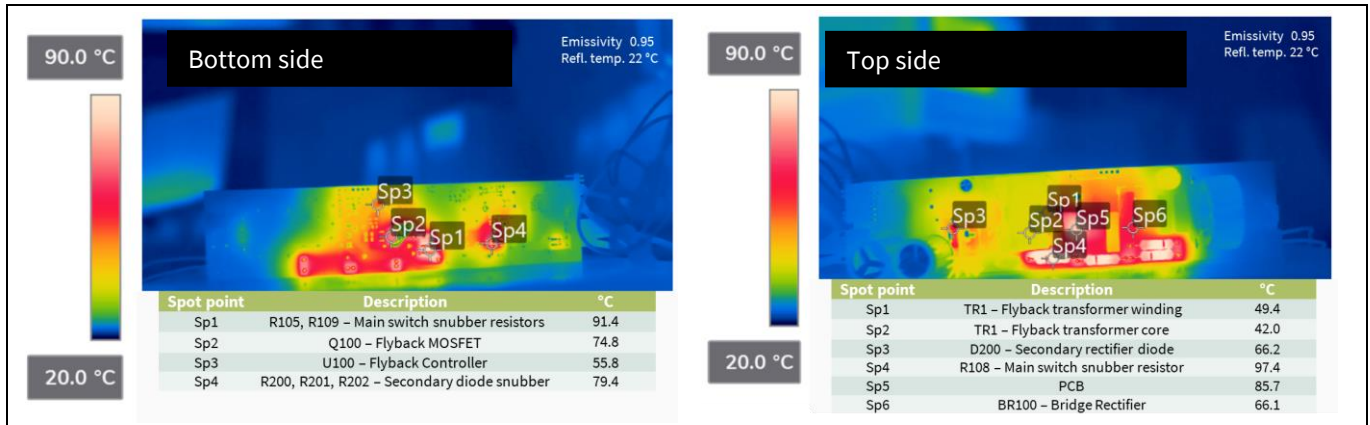

Figure 13 IR thermal image at 230 V AC input

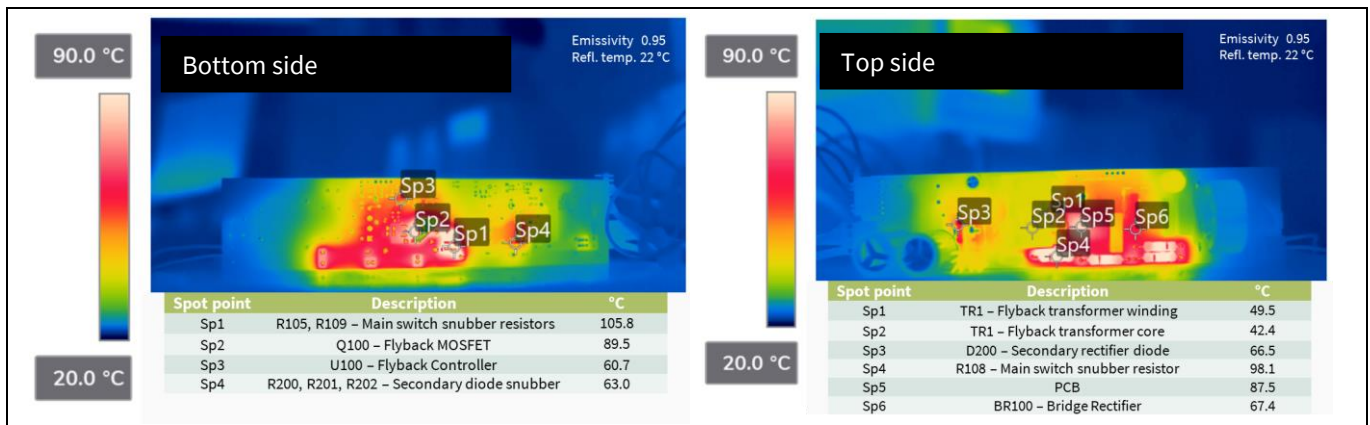

Figure 14 IR thermal image at 115 V AC input

Performance

5.6 Conducted emissions (EN 55022 class B)

The conducted emissions test is performed at full output power (116 W) based on EN 55022 standard Class B limits, as shown in Figure 15 and Figure 16.

The measurement equipment used for this conducted emissions test was Rohde & Schwarz HM6050-2 and Tektronix RSA503A.

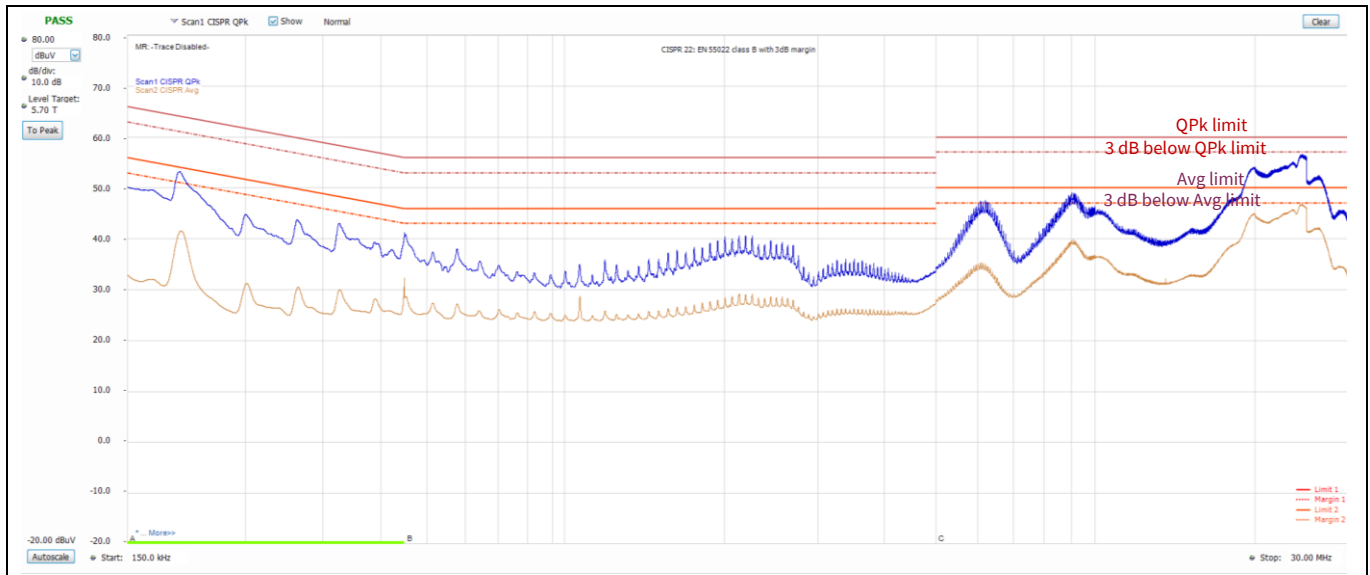

Figure 15 Conducted emissions (live) test result at $V_{AC} = 115 V_{RMS}$, $F_{line} = 50 \text{ Hz}$, $P_{out} = 116 \text{ W}$

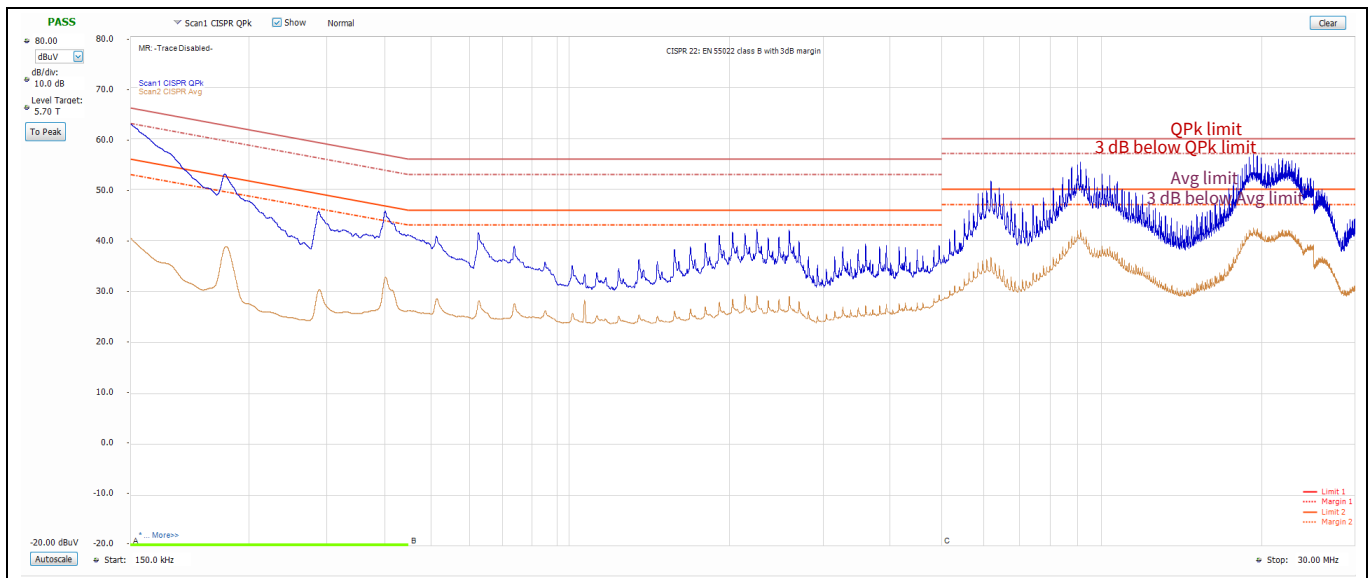

Figure 16 Conducted emissions (live) test result at $V_{AC} = 230 V_{RMS}$, $F_{line} = 50 \text{ Hz}$, $P_{out} = 116 \text{ W}$

Bill of materials and transformer specifications

6 Bill of materials and transformer specifications

This section provides the bill of materials (BOM) and the transformer specifications.

6.1 BOM

Table 7 BOM of the reference design board

Designator	Description	Part number	Manufacturer
BR100	Dio GBU806// THT//	GBU806	Diodes Incorporated
C17	Cap 3.2nF// THT 9.5mm// /20%	440LD32-R	Vishay
C100	Cap 220nF/ 630V/ THT/Radial// /10%	890334025027CS	Würth Elektronik
C101	Cap 2.2nF/ 630V/ 1206/ X7R/10%	GRM31AR72J222KW01	Murata
C102	Cap 470nF/ 630V/ THT/Radial// /10%	890324025039CS	Würth Elektronik
C103, C104	Cap 150nF/ 630V/ THT/Radial// /10%	890334025022CS	Würth Elektronik
C105	Cap 22uF/ 50V/ THT/Radial// /20%	860080672001	Würth Elektronik
C106	Cap 100pF/ 1kV/ 1206/ C0G/5%	GRM31A5C3A101JW01	Murata
C107, C109, C208, C209, C211, C212	Cap 100nF/ 50V/ 0603/ X7R/10%	06035C104K4Z2A	AVX
C108	Cap 470pF/ 50V/ 0603/ X7R/10%	885012206081	Würth Elektronik
C200	Cap 1nF/ 630V/ 1206/ C0G/5%	CGA5F4C0G2J102J085AA	TDK Corporation
C201, C203	Cap 1.8mF/ 80V/ THT/Radial// /20%	EKZN800ELL182MM40S	Nippon Chemi-Con
C204	Cap 1uF/ 100V/ 1206/ X7R/10%	12061C105KAT2A	AVX
C205	Cap 100nF/ 100V/ 3216 (1206)// /10%	CGA5H2X8R2A104K115AA	TDK Corporation
C207	Cap 220uF/ 35V/ THT/Radial// /20%	860010574011	Würth Elektronik
C210, C213	Cap 1uF/ 50V/ 0805/ X7R/10%	GCM21BR71H105KA03	Murata
C214	Cap 10nF/ 50V/ 0805/ X7R/10%	C0805C103K5RACAUTO	Kemet
C215	Cap 1nF/ 50V/ 0603/ C0G/1%	C0603C102F5GAC	Kemet
C217	Cap 470nF/ 25V/ 0603/ X7R/10%	GCM188R71E474KA64	Murata
C219	Cap 10nF/ 16V/ 0603/ X7R/10%	885012206040	Würth Elektronik
C222	Cap 4.7uF/ 50V/ 0805/ X5R/10%	GRM21BR61H475KE51	Murata
C223	Cap 4.7uF/ 25V/ 0805/ X7R/10%	GRM21BR71E475KA73	Murata
D100	Dio ES1J// SMA (DO-214AC)//	ES1J	ON Semiconductor
D101, D102	Dio 1N4006G// DO-41 (Case 59-10)//	1N4006G	ON Semiconductor
D103, D201	Dio PMEG150G20ELR// SOD123W//	PMEG150G20ELR	Nexperia
D104	Dio 22V// SOD-123//	MMSZ22T1G	ON Semiconductor
D200	Dio RF2001T3DNZC9// TO-220FN-3//	RF2001T3DNZC9	ROHM Semiconductors
D202, D203	Dio BAV16WS-7-F// SOD-323//	BAV16WS-7-F	Diodes Incorporated
F100	Res Fuse 300V / 3.15A/ 300V/ THT/Radial//	SS-5H-3.15A-APH	Bussmann

Bill of materials and transformer specifications

Designator	Description	Part number	Manufacturer
HS200	Mec 513002B02500G// Heatsink, TO-220, 34.92mm L X 12.7mm W X 25.4mm H//	513002B02500G	Aavid Thermalloy
L100	Ind 470uH// Radial Type//10%	7447480471	Würth Elektronik
L101	Ind 20mH// THT//	8110-RC	Bourns
MOV100, MOV101	Res 560V/ 460V/ THT//	MOV-10D561K	Bourns
PC1	TLP383(GR-TPL,E// TLP383//	TLP383	Toshiba
Q100	Tra IPD80R280P7// PG-TO252-3-313//	IPD80R280P7	Infineon Technologies
R100, R103, R106, R108	Res 4.7k/ 750V/ THT/Axial/ /5%	RR03J4K7TB	TE Connectivity
R101, R107	Res 620k/ 200V/ 1206/ /1%	CRCW1206620KFK	Vishay
R102, R104, R110	Res 180k/ 200V/ 1206/ /1%	CRCW1206180KFK	Vishay
R105, R109	Res 56R/ 200V/ 1210/ /1%	CRCW121056R0FK	Vishay
R111, R121, R130, R220	Res 0R/ 75V/ 0603/ /0R	RC0603JR-070RL	Yageo
R112, R117	Res 10R/ 150V/ 0805/ /1%	RC0805FR-0710RL	Yageo
R113, R114	Res 2.7MEG/ 200V/ 1206/ /1%	CRCW12062M70FK	Vishay
R115	Res 620k/ 200V/ 1206/ /1%	CRCW1206620KFK	Vishay
R116	Res 47k/ 200V/ 0805/ /1%	ERJ-6ENF4702V	Panasonic
R118	Res 39k/ 75V/ 0603/ /1%	CRCW060339K0FK	Vishay
R120	Res 10k/ 150V/ 805/ /5%	RMCF0805JT10K0	Stackpole Electronics
R122	Res 2.7k/ 150V/ 0805/ /1%	CRCW08052K70FK	Vishay
R123, R124	Res 180mR// 1206/ /1%	KDV12FR180ET	Ohmite
R125	Res 39k/ 75V/ 0603/ /1%	RC0603FR-0739KL	Yageo
R126, R127, R129, R205, R221, R232	Res 0R// THT/Axial//	ZOR-12-R-52-0R	Yageo
R128	Res 12k/ 50V/ 0603/ /1%	RC0603FR-0712KL	Yageo
R200, R201, R202	Res 47R/ 200V/ 1206/ /1%	CRCW120647R0FKEAHP	Vishay
R203	Res 0R/ 150V/ 805/ /	RMCF0805ZT0R00	Stackpole Electronics
R206, R207, R208, R214	Res 1k/ 75V/ 0603/ /1%	ERJ3EKF1001V	Panasonic
R209, R211	Res 20k/ 50V/ 0603/ /1%	MCR03EZPFX2002	ROHM Semiconductors
R210	Res 1.5k/ 75V/ 0603/ /1%	RC0603FR-071K5L	Yageo
R213	Res 30k/ 75V/ 0603/ /1%	CRCW060330K0FK	Vishay
R215	Res 5.6k/ 75V/ 0603/ /1%	CRCW06035K60FK	Vishay
R216	Res 5.1k/ 200V/ 1206/ /1%	CRCW12065K10FK	Vishay

Bill of materials and transformer specifications

Designator	Description	Part number	Manufacturer
R222	Res 120k/ 75V/ 0603/ /1%	CRCW0603120KFK	Vishay
R224	Res 0R/ 200V/ 1206/ /0%	CRCW12060000Z0EA	Vishay
R226	Res 8.2k/ / 0603/ /1%	CRCW06038K20FKEAC	Vishay
R227	Res 27k/ 75V/ 0603/ /1%	CRCW060327K0FK	Vishay
R228	Res 100mR/ / 1206/ /1%	ERJ8BWFR100V	Panasonic
TR1	Tra NP2023-16632/ / THT/ /	NP2023-16632	ICT
U100	Int ICL8810/ / PG-DSO-8/ /	ICL8810	Infineon Technologies
U200	Ana TLV9102IDR/ / SOIC-8/ /	TLV9102IDR	Texas Instruments
U201	Pow MCP1799T-5002H/TT/ / SOT23/ /	MCP1799T-5002H/TT	Microchip Technology
X100	Con 250-203/ / THT/ /	250-203	WAGO
Xout200	Con 691322310004/ / WR-TBL/ /	691322310004	Würth Elektronik
Xout201	Con 613007143121/ / THT 7 PIN 2.54 mm pitch/ /	613007143121	Würth Elektronik

Bill of materials and transformer specifications

6.2 Transformer specifications

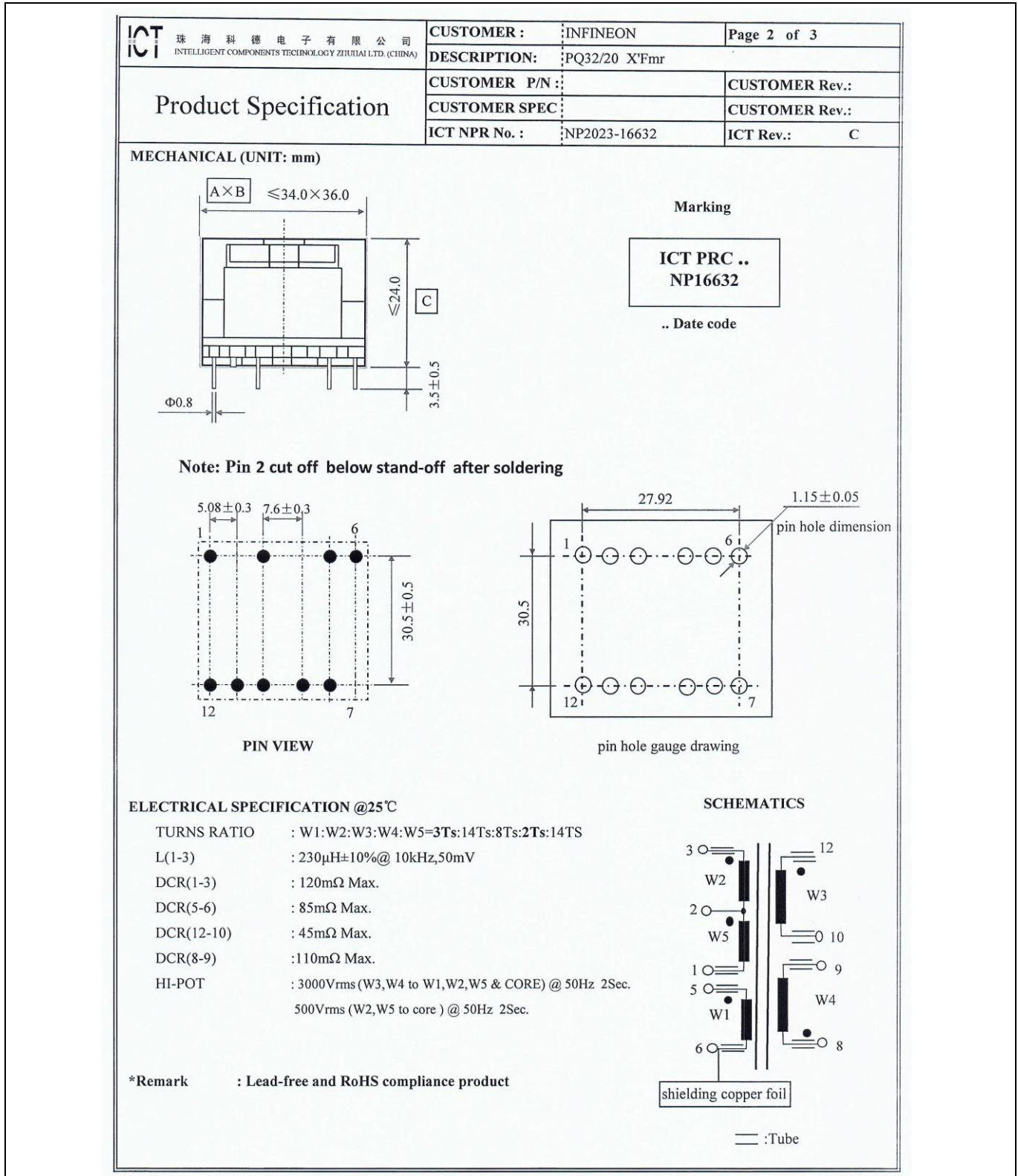

Figure 17 Flyback transformer (TR1) mechanical and electrical specifications

Bill of materials and transformer specifications

珠海科德电子有限公司 INTELLIGENT COMPONENTS TECHNOLOGY ZHUFUJIAI LTD. (CHINA)	CUSTOMER :	INFINEON	Page 3 of 3
	DESCRIPTION:	PQ32/20 X'Fmr	
	CUSTOMER P/N :		CUSTOMER Rev.:
	CUSTOMER SPEC:		CUSTOMER Rev.:
Product Specification	ICT NPR No. :	NP2023-16632	ICT Rev.: C
<p>MATERIALS:</p> <p>BOBBIN : PQ32, Vertical, 1Section, PHENOLIC (PM-9820 or T375HF)</p> <p>CORE : PQ32/20, TPW33 or DMR95 or PG312 or HC95 or HPP-95 or equal, GAP=2*0.29mm</p> <p>WIRE : (W1)Φ0.25mm, 1UEW or 2UEW, 155°C, C</p> <p style="margin-left: 150px;">:(W2,W5) 45*0.1mm 1UEW or 2UEW, 155°C</p> <p style="margin-left: 150px;">:(W3) 35*0.1 TIW-B(LZ) or equal</p> <p style="margin-left: 150px;">:(W4) 0.20mm, TIW-B or equal</p> <p>TAPE : 10mm width & 15mm width & 17mm width, #1350F-1 or CT280 or equal</p> <p>TUBE : Teflon tube, AWG#17L,AWG#26L,AWG#30L</p> <p>GLUE : F121A/B or TA452A/B or LO-200QA/B</p> <p>VARNISH : V1630FS or BC-359 or equal</p> <p>COPPER FOIL : 10mm width</p> <p>WINDING CONSTRUCTION</p> <div style="border: 1px solid black; padding: 5px; margin: 10px auto; width: fit-content;"> <p style="text-align: center;">Tape: 2 layers</p> <hr/> <p style="text-align: center;">W5:45*0.1 UEW 14ts, start 2, finish 1</p> <hr/> <p style="text-align: center;">Tape: 2 layers or 3 layers</p> <hr/> <p style="text-align: center;">W4: Φ0.2mm, TIW-B , 2ts, start 8, finish 9</p> <hr/> <p style="text-align: center;">Tape: 3 layers</p> <hr/> <p style="text-align: center;">W3: 35*0.1mm, TIW-B(LZ) 8ts, start 12, finish 10</p> <hr/> <p style="text-align: center;">Tape: 3 layers</p> <hr/> <p style="text-align: center;">W2:45*0.1 UEW 14ts, start 3, finish 2</p> <hr/> <p style="text-align: center;">Tape: 2 layers</p> <hr/> <p style="text-align: center;">W1: Φ0.25mm, UEW, 3ts, start 5, finish 6</p> </div> <p style="text-align: center; margin-top: 10px;">NOTE : one layer of tape between layer and layer for W2 winding and W5 winding</p>			
Rev.	Change history		
A			
B	change W1 turns from 4 to 3 and change W4 turns from 3 to 2		
C	correct core material and add varnish		

Figure 18 Flyback transformer (TR1) materials and winding construction specifications

Revision history

Revision history

Document revision	Date	Description of changes
V 1.0	2023-11-17	Initial release

Trademarks

All referenced product or service names and trademarks are the property of their respective owners.

Edition 2023-11-17

Published by

Infineon Technologies AG

81726 Munich, Germany

© 2023 Infineon Technologies AG.

All Rights Reserved.

Do you have a question about this document?

Email:

erratum@infineon.com

Important notice

The information given in this document shall in no event be regarded as a guarantee of conditions or characteristics ("Beschaffheitsgarantie").

With respect to any examples, hints or any typical values stated herein and/or any information regarding the application of the product, Infineon Technologies hereby disclaims any and all warranties and liabilities of any kind, including without limitation warranties of non-infringement of intellectual property rights of any third party.

In addition, any information given in this document is subject to customer's compliance with its obligations stated in this document and any applicable legal requirements, norms and standards concerning customer's products and any use of the product of Infineon Technologies in customer's applications.

The data contained in this document is exclusively intended for technically trained staff. It is the responsibility of customer's technical departments to evaluate the suitability of the product for the intended application and the completeness of the product information given in this document with respect to such application.

Warnings

Due to technical requirements products may contain dangerous substances. For information on the types in question please contact your nearest Infineon Technologies office.

Except as otherwise explicitly approved by Infineon Technologies in a written document signed by authorized representatives of Infineon Technologies, Infineon Technologies' products may not be used in any applications where a failure of the product or any consequences of the use thereof can reasonably be expected to result in personal injury.

X-ON Electronics

Largest Supplier of Electrical and Electronic Components

Click to view similar products for [Power Management IC Development Tools](#) category:

Click to view products by [Infineon](#) manufacturer:

Other Similar products are found below :

[EVB-EP5348UI](#) [BQ25010EVM](#) [ISL80019AEVAL1Z](#) [ISLUSBI2CKIT1Z](#) [ISL8002AEVAL1Z](#) [ISL91108IIA-EVZ](#) [ISL28022EVKIT1Z](#)
[STEVAL-ISA008V1](#) [DRI0043](#) [KITPF8100FRDMEVM](#) [EVB-EN6337QA](#) [SAMPLEBOXILD8150TOBO1](#) [AP62300WU-EVM](#)
[KITA2GTC387MOTORCTRTOBO1](#) [AEK-MOT-TK200G1](#) [EVLONE65W](#) [STEVAL-ILH006V1](#) [STEVAL-IPE008V2](#) [STEVAL-IPP001V2](#)
[STEVAL-ISA013V1](#) [STEVAL-ISA067V1](#) [STEVAL-ISQ002V1](#) [TPS2306EVM-001](#) [TPS2330EVM-185](#) [TPS40001EVM-001](#) [SECO-](#)
[HVDCDC1362-15W-GEVB](#) [BTS7030-2EPA](#) [LT8638SJV#WPBF](#) [LTC3308AIV#WTRPBF](#) [BTS71033-6ESA](#) [EV13N91A](#) [EASYPIC V8](#)
[OVER USB-C](#) [EV55W64A](#) [CLICKER 4 FOR STM32F4](#) [EASYMX PRO V7A FOR STM32](#) [CLICKER 4 FOR PIC18F](#) [Si8285_86v2-KIT](#)
[PAC52700EVK1](#) [NCP-NCV51752D2PAK3LGEVB](#) [ISL81807EVAL1Z](#) [AP33772S-EVB](#) [EVALM7HVIGBTTPFCINV4TOBO1](#) [903-0300-000](#)
[902-0173-000](#) [903-0301-000](#) [ROA1286023/1](#) [REFSHA35IMD111TSYSTOBO1](#) [150037482](#) [SABMB629](#) [TDINV3000W50B-KIT](#)