

Solid-state circuit breaker reference design user guide

About this document

Scope and purpose

This user guide describes the setup and evaluation of the solid-state circuit breaker (SSCB) reference design: REF_SSCB_AC_DC_1PH_16A. It provides a brief overview of the SSCB reference design concept, functions, and protection and diagnosis implementations.

Intended audience

This document is intended for engineers who want to start software development, perform measurements, and check performances using the SSCB reference design board.

Reference board/kit

Product(s) embedded on a PCB with a focus on specific applications and defined use cases that may include software. PCB and auxiliary circuits are optimized for the requirements of the target application.

Note: Boards do not necessarily meet safety, EMI, and quality standards (for example, UL and CE) requirements.

Important notice

Important notice

“Evaluation Boards and Reference Boards” shall mean products embedded on a printed circuit board (PCB) for demonstration and/or evaluation purposes, which include, without limitation, demonstration, reference and evaluation boards, kits and design (collectively referred to as “Reference Board”).

Environmental conditions have been considered in the design of the Evaluation Boards and Reference Boards provided by Infineon Technologies. The design of the Evaluation Boards and Reference Boards has been tested by Infineon Technologies only as described in this document. The design is not qualified in terms of safety requirements, manufacturing and operation over the entire operating temperature range or lifetime.

The Evaluation Boards and Reference Boards provided by Infineon Technologies are subject to functional testing only under typical load conditions. Evaluation Boards and Reference Boards are not subject to the same procedures as regular products regarding returned material analysis (RMA), process change notification (PCN) and product discontinuation (PD).

Evaluation Boards and Reference Boards are not commercialized products, and are solely intended for evaluation and testing purposes. In particular, they shall not be used for reliability testing or production. The Evaluation Boards and Reference Boards may therefore not comply with CE or similar standards (including but not limited to the EMC Directive 2004/EC/108 and the EMC Act) and may not fulfill other requirements of the country in which they are operated by the customer. The customer shall ensure that all Evaluation Boards and Reference Boards will be handled in a way which is compliant with the relevant requirements and standards of the country in which they are operated.

The Evaluation Boards and Reference Boards as well as the information provided in this document are addressed only to qualified and skilled technical staff, for laboratory usage, and shall be used and managed according to the terms and conditions set forth in this document and in other related documentation supplied with the respective Evaluation Board or Reference Board.

It is the responsibility of the customer’s technical departments to evaluate the suitability of the Evaluation Boards and Reference Boards for the intended application, and to evaluate the completeness and correctness of the information provided in this document with respect to such application.

The customer is obliged to ensure that the use of the Evaluation Boards and Reference Boards does not cause any harm to persons or third party property.

The Evaluation Boards and Reference Boards and any information in this document is provided "as is" and Infineon Technologies disclaims any warranties, express or implied, including but not limited to warranties of non-infringement of third party rights and implied warranties of fitness for any purpose, or for merchantability.

Infineon Technologies shall not be responsible for any damages resulting from the use of the Evaluation Boards and Reference Boards and/or from any information provided in this document. The customer is obliged to defend, indemnify and hold Infineon Technologies harmless from and against any claims or damages arising out of or resulting from any use thereof.

Infineon Technologies reserves the right to modify this document and/or any information provided herein at any time without further notice.

Safety precautions

Safety precautions

Note: Please note the following warnings regarding the hazards associated with development systems

Table 1 Safety precautions

	<p>Warning: The evaluation or reference board is connected to the grid input during testing. Hence, high-voltage differential probes must be used when measuring voltage waveforms by oscilloscope. Failure to do so may result in board damage or personal injury.</p>
	<p>Warning: 16 A mechanical relay is provided on reference boards as safety relay. Using this relay outside manufacturer specification will degrade its contacts. Failure of relay contacts as short or bypassing its contacts results into free air isolation loss. To test high current beyond relay specification, suggest bypassing relay contacts and use external suitable safety relay.</p>
	<p>Warning: Remove or disconnect grid input power from the boards before you disconnect or reconnect wires or perform maintenance work. Failure to do so may result in personal injury or death. GUI or display measurements may not be an indication that supply is at safe voltage levels as communication may get interrupted during testing.</p>
	<p>Caution: Only personnel familiar with power electronics and associated machinery should plan, install, commission, and subsequently service the system. Failure to comply may result in personal injury and/or equipment damage.</p>
	<p>Caution: The evaluation or reference board contains parts and assemblies sensitive to electrostatic discharge (ESD). Electrostatic control precautions are required when installing, testing, servicing, or repairing the assembly. Component damage may result if ESD control procedures are not followed. If you are not familiar with electrostatic control procedures, refer to the applicable ESD protection handbooks and guidelines.</p>
	<p>Caution: A load and/or boards that are incorrectly applied or installed can lead to component damage or reduction in product lifetime. Wiring or application errors such as undersizing the load or wires, supplying an incorrect or inadequate AC supply, or excessive ambient temperatures may result in system malfunction.</p>
	<p>Caution: The evaluation or reference board is shipped with packing materials that need to be removed prior to installation. Failure to remove all packing materials that are unnecessary for system installation may result in overheating or abnormal operating conditions.</p>

Table of contents

Table of contents

About this document.....	1
Important notice	2
Safety precautions.....	3
Table of contents.....	4
1 SSCB device at a glance.....	5
1.1 Main features	5
1.2 SSCB reference design key parameters.....	6
1.3 Scope of supply	7
1.4 SSCB hardware concept.....	9
1.5 Hardware overview	11
2 SSCB Demo GUI	15
2.1 GUI main window	15
2.2 GUI configuration window	17
2.2.1 SSCB in-application calibration	18
2.3 GUI trip chart window	20
2.3.1 SSCB overload errors	21
2.4 GUI real-time graph window	23
3 SSCB front panel	25
4 Getting started	26
5 CAN communication	27
5.1 Communication interface	27
5.1.1 CAN command list.....	28
6 SSCB Demo performance test	34
6.1 ZVS and ZCS in AC SSCB.....	34
6.2 OCD performance.....	35
6.3 Thermal performance	36
Glossary	39
Revision history.....	41
Disclaimer.....	42

SSCB device at a glance

1 SSCB device at a glance

In solid-state circuit breakers (SSCB), as the name indicates, there are no mechanical contacts for high current switching/commutation. Absence of moving parts for commutation makes them more reliable because of arc-free switching and being less prone to wear and tear over lifetime. Solid-state switches provide fast, precise, and reliable short-circuit protection. With advancement in digitization and semiconductor technologies, SSCB can be integrated with smart grid technologies to provide advanced monitoring and control capabilities together with secured communication.

The SSCB reference design (REF_SSCB_AC_DC_1PH_16A) is suitable for 16 A nominal current and AC (110/230 V) or DC (350 V) grid supply. AC or DC mode selection is software-based through GUI. This design allows application-level evaluation of CoolMOS™ S7T power devices in combination with application-relevant protection, monitoring, and diagnostic concept.

This kit follows the two-board approach, comprising a power and a logic board. The power board holds the power stage, airgap device, and flyback power supply. The logic board has all the low-power features such as the supply generation for MCU, analog signal processing, isolated backplane bus, and external user bus infrastructures.

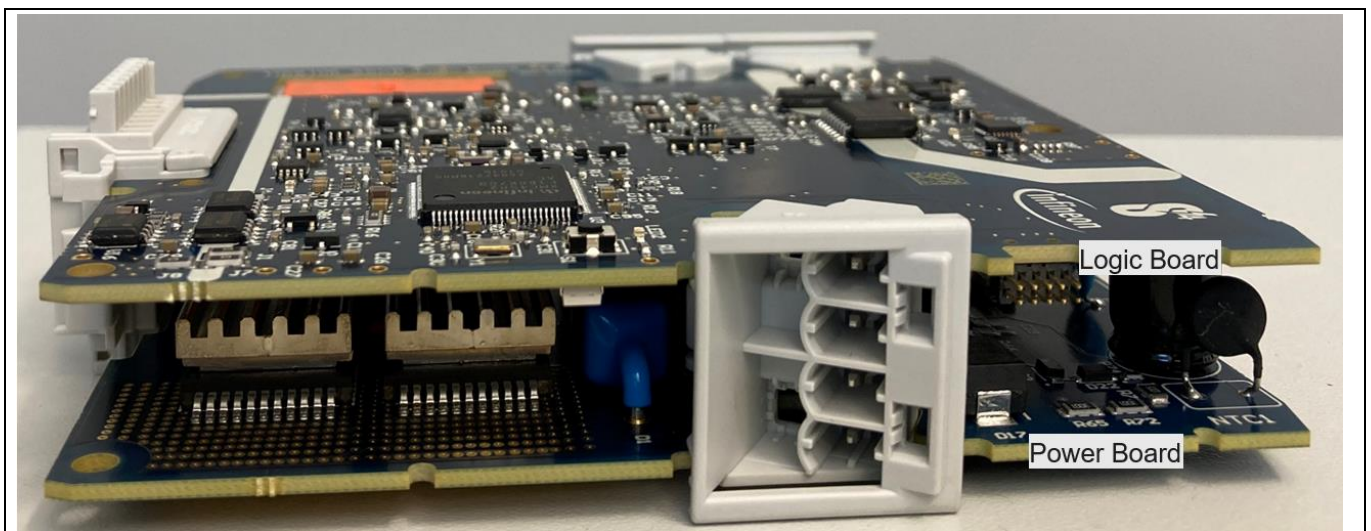

Figure 1 SSCB reference design boards

1.1 Main features

The key electrical features of SSCB reference design are as follows:

- Floating switch: Back-to-back (B2B) CoolMOS™ configuration for bidirectional current blocking capability
- CoolMOS™ S7T power FETs with embedded temperature sensor for measuring the junction temperature (T_j)
- Passive cooling with top-side cooling (TSC) concept: Cu heatsink soldered over MOSFET
- External user interface bus in safety extra low voltage (SELV) domain: High-speed CAN and digital inhibit input
- Isolated backplane communication bus (for multichannel configuration) in functional extra low voltage (FELV) domain – UART and bidirectional digital I/O signal
- Protection and monitoring provisions
 - Shunt resistor-based channel current measurement
 - Shunt resistor-based overcurrent detection (OCD)

SSCB device at a glance

- Isolated channel input and output voltage measurement
- Individual MOSFET T_j measurement
- Overload (OVL), overtemperature (OVT), undervoltage (UVP), and overvoltage protection (OVP)
- Programmability and monitoring with SSCB Demo graphical user interface (GUI)
 - AC or DC operation selection
 - Positive and negative OCD trip thresholds
 - Overtemperature shutdown and recovery thresholds
 - UVP and OVP thresholds
 - Trip chart parameters: Nominal current, static overdrive factor, fast and slow overcurrent factors, tripping integral
 - In-application programming to calibrate the channel input and output voltage and current
 - Monitoring and export of analog measurements like V_{in} , V_o , I , f , P , power factor, OCD threshold references, T_j
- TFT display to monitor V , I , P , f , T_j , SSCB state, diagnostic information
- F-RAM for data logging
- Self-Powered: Flyback power supply from grid; no external supply needed

1.2 SSCB reference design key parameters

This SSCB reference design is AC- and DC-agnostic. AC or DC selection can be enabled by SSCB Demo GUI.

Table 2 Parameter

Parameter	Min	Typ	Max	Unit
Absolute maximum channel supply range	90	–	260	V AC
	120	–	375	V DC
Operating channel supply range	100	–	240	V AC
	330	–	370	V DC
Nominal current at $T_a=25^\circ\text{C}$	–	16	–	A
Static over drive factor at $T_a=25^\circ\text{C}$	–	–	1.13	–
I^2t limit value	–	–	100k	A^2s
RMS over current for 100 ms at $T_a=25^\circ\text{C}$	–	–	80	A
Frequency modes	DC/50/60 Hz			
Positive/negative OCD trip current limit at di/dt : 10-15 A/ μs	–	–	145	A
Maximum di/dt for OCD	100 A/ μs			
Maximum MOSFET switch off current	See the IPDQ60R010S7 datasheet.			
Pollution degree	II			
Overvoltage category	II			
Maximum altitude	2000 m			
Ambient operating temperature (T_a)	–	25	40	$^\circ\text{C}$

SSCB device at a glance

Table 3 External user interface Parameter

Parameter	Min	Typ	Max	Unit
Supply absolute maximum rating	-40	-	40	V
Supply operating range	21	24	27	V
Supply current requirement	0.1	-	-	A
INHIBIT pin absolute rating	-40	-	40	V
INHIBIT HIGH level	8	-	27	V
INHIBIT LOW level	0	-	1.5	V
INHIBIT pin input impedance	-	1.2k	-	Ω
INHIBIT pin internal pull-down resistance	-	30k	-	Ω
High-speed CAN specification	V2.0 B active			
CAN baud rate	500			kbps

There is provision to provide external DC supply (18–20 V) either on the logic or power board for development purpose.

1.3 Scope of supply

This reference design kit contains the following:

- **SSCB device:** SSCB logic and power boards fitted inside housing with a TFT display and keyboard
- **SSCB Demo GUI:** Available via MyICP
- **USB to CAN analyzer:** SEED STUDIO 114991193
- **24 V, 1 A adapter:** XP Power VER24US240-YES or similar

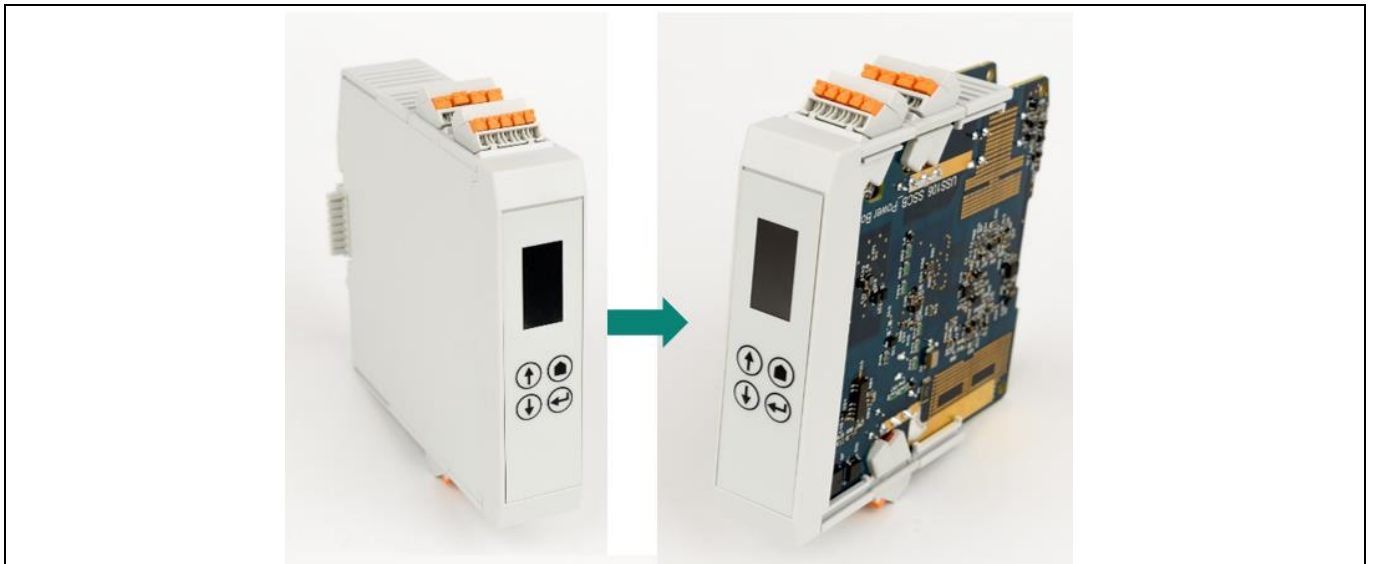

Figure 2 SSCB device

SSCB device at a glance

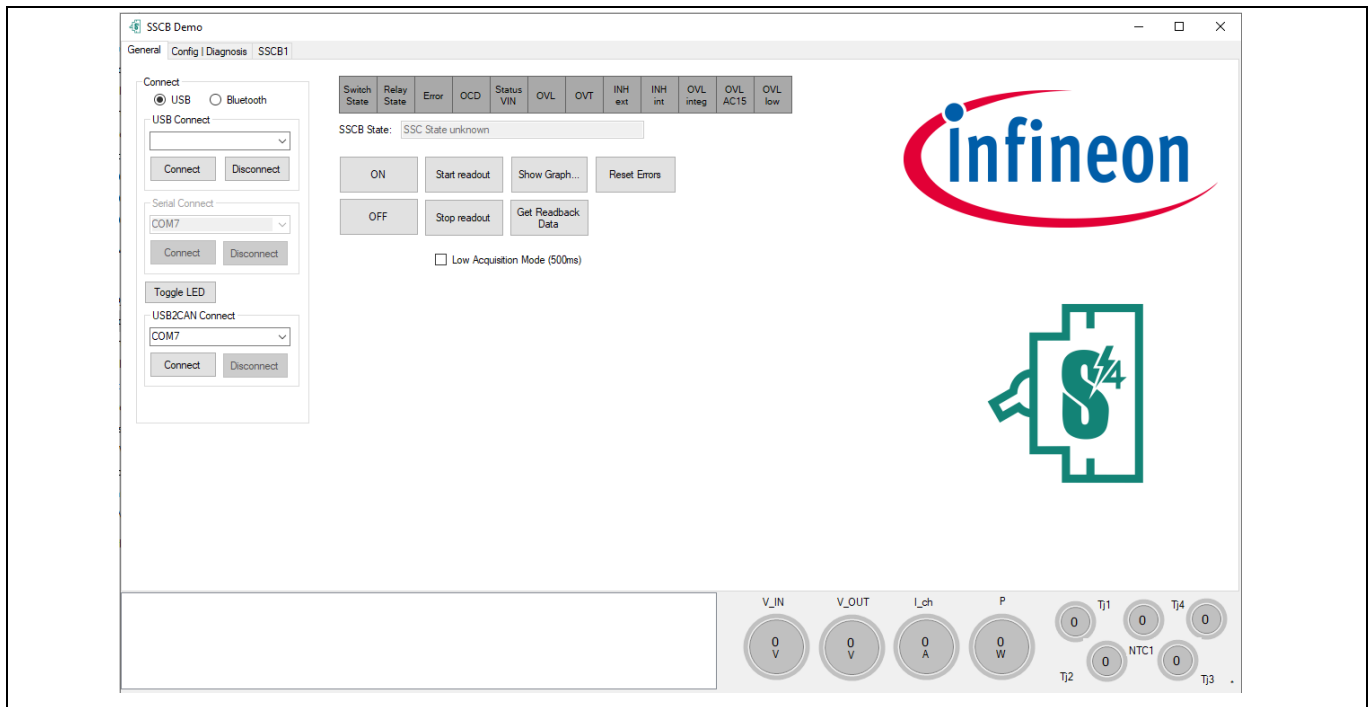

Figure 3 SSCB Demo GUI



Figure 4 USB2CAN analyzer



Figure 5 24 V, 1 A adapter

Note:

1. For XMC4x MCU software development, please order a J-Link programmer/debugger separately. See [KIT_XMC_LINK_SEGGER_V1](#).
2. XMC4x firmware uses DAVE™ 4 IDE; the SSCB Demo GUI uses Visual Studio C# for development.

SSCB device at a glance

1.4 SSCB hardware concept

As shown in [Figure 6](#), to support bidirectional current blocking capability, B2B MOSFETs are used as the channel switch with TVS diode across it to clamp the inductive energy. The safety relay is placed in between the B2B switch and output terminal to have the air gap in the channel off state. A microcontroller reads the input and output voltages together with the channel current and the MOSFET's junction temperature (T_j).

Two communication interfaces are available:

- **External user interface bus to connect with the GUI:** It gets the power supply from an external 24 V supply (24 V, 1 A adapter [Figure 5](#)).
- **Internal backplane bus to support multichannel configuration:** Its 5 V supply is provided by the master unit to the slave units in multichannel configuration.

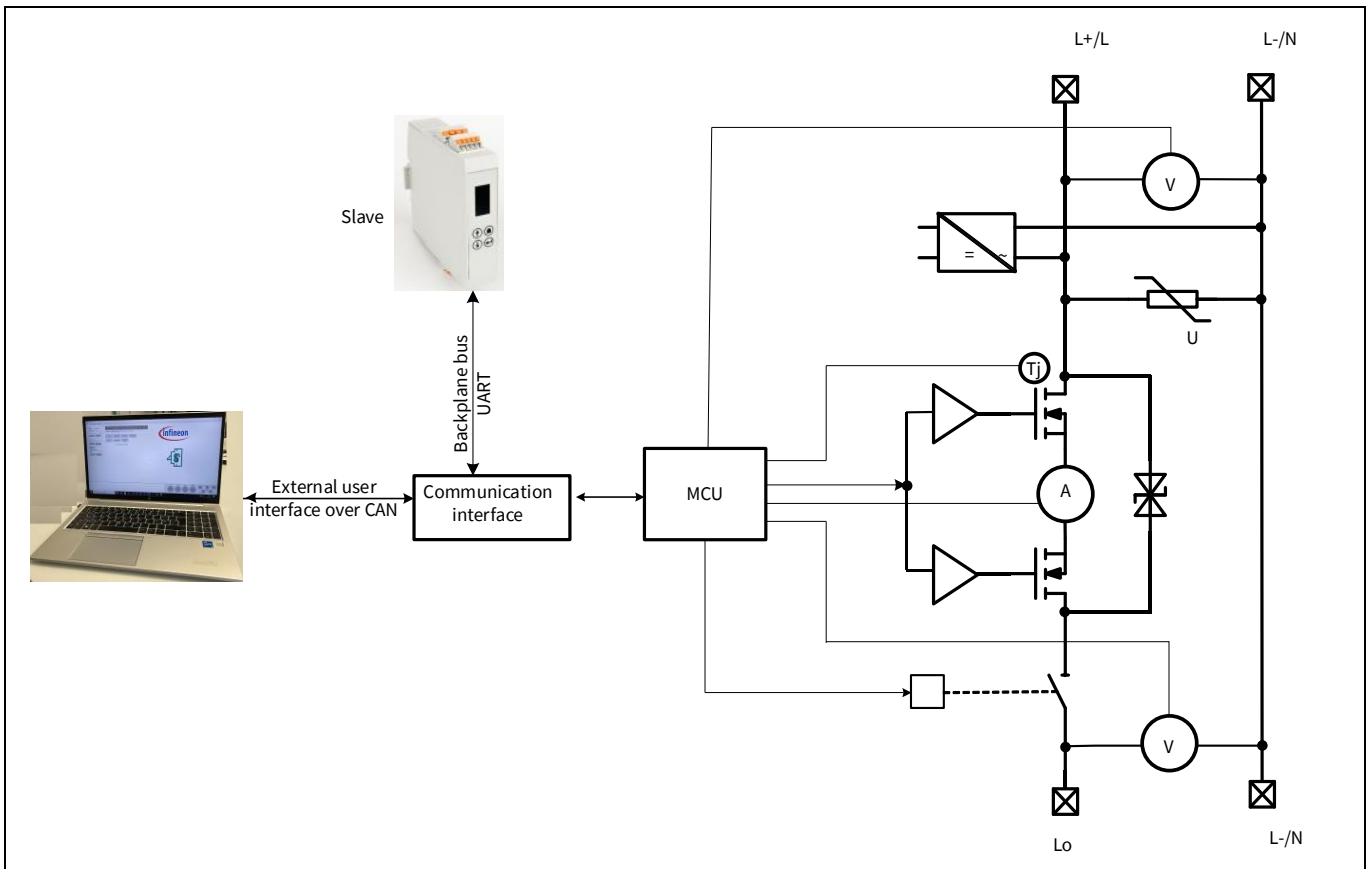

Figure 6 Block scheme

As shown in [Figure 7](#), this design has two isolation domains: FELV and SELV isolation.

In the FELV domain supply, a flyback converter is used to generate an isolated 19 V supply from the grid. 19 V is generated reference to the common source (GND_{HV}) connection of the B2B MOSFET switch. The flyback converter provides flexibility to keep a common hardware design for AC and DC SSCB. The main MCU (XMC4502x), analog section, and internal backplane are placed in the FELV domain reference to GND_{HV} .

The SELV domain is supplied by an external SELV-compliant 24 V supply. The SELV domain provides an isolated CAN interface directly with the main MCU (XMC4502x) to connect with the SSCB Demo GUI. XMC1302x communicates with XMC4502x over UART through a digital isolator and shows the measurements over the TFT display.

SSCB device at a glance

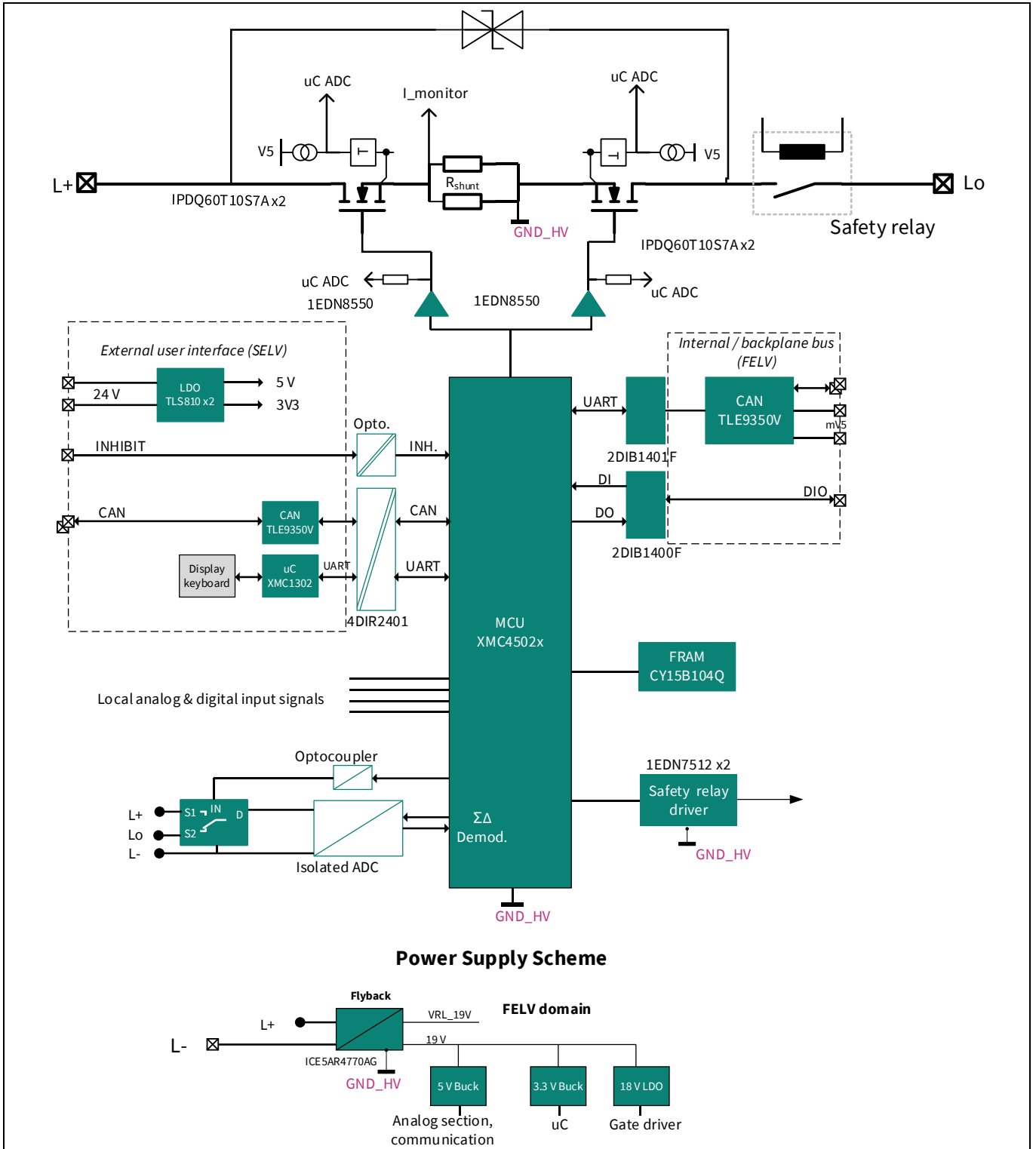

Figure 7 SSCB detailed block scheme

SSCB device at a glance

1.5 Hardware overview

This section describes the technical details and usage of the hardware. The hardware is shown in [Figure 8](#) and [Figure 9](#). [Figure 10](#) shows the connectors pin assignments. [Figure 11](#) shows an example of how to remove the front panel of the housing.

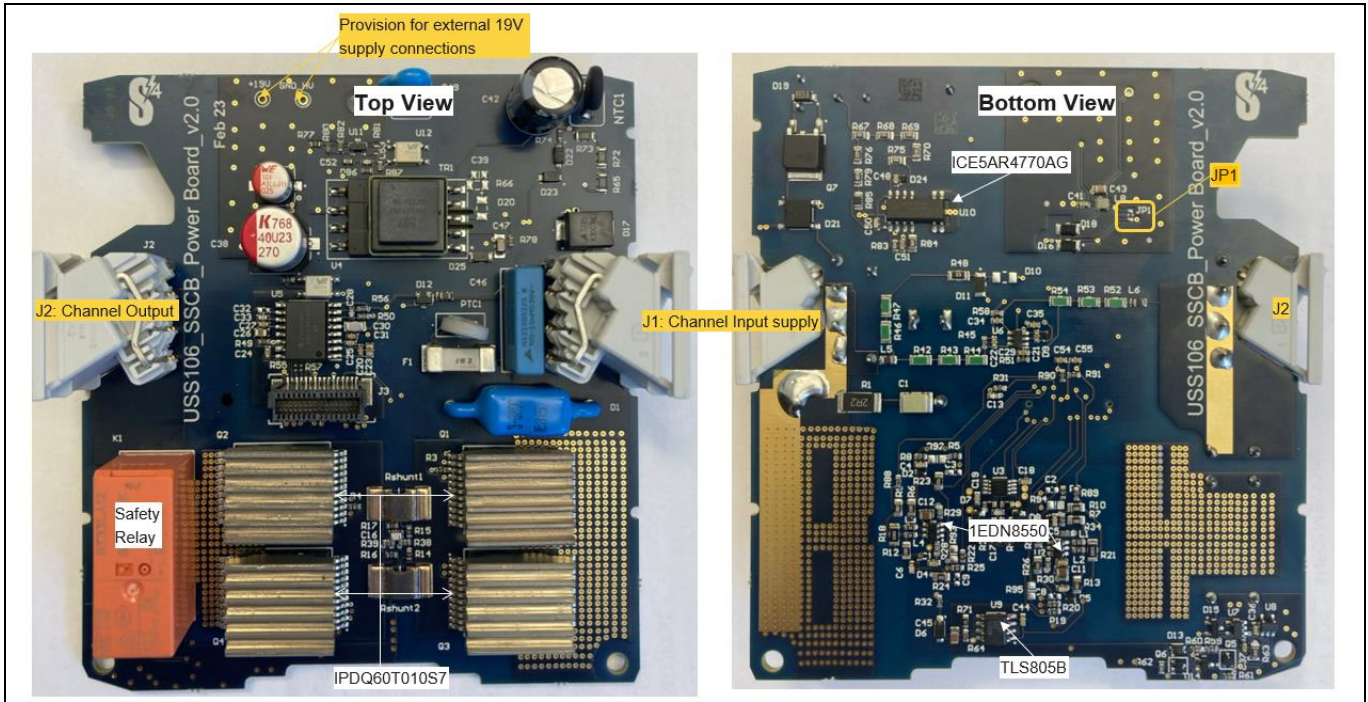

Figure 8 Power board

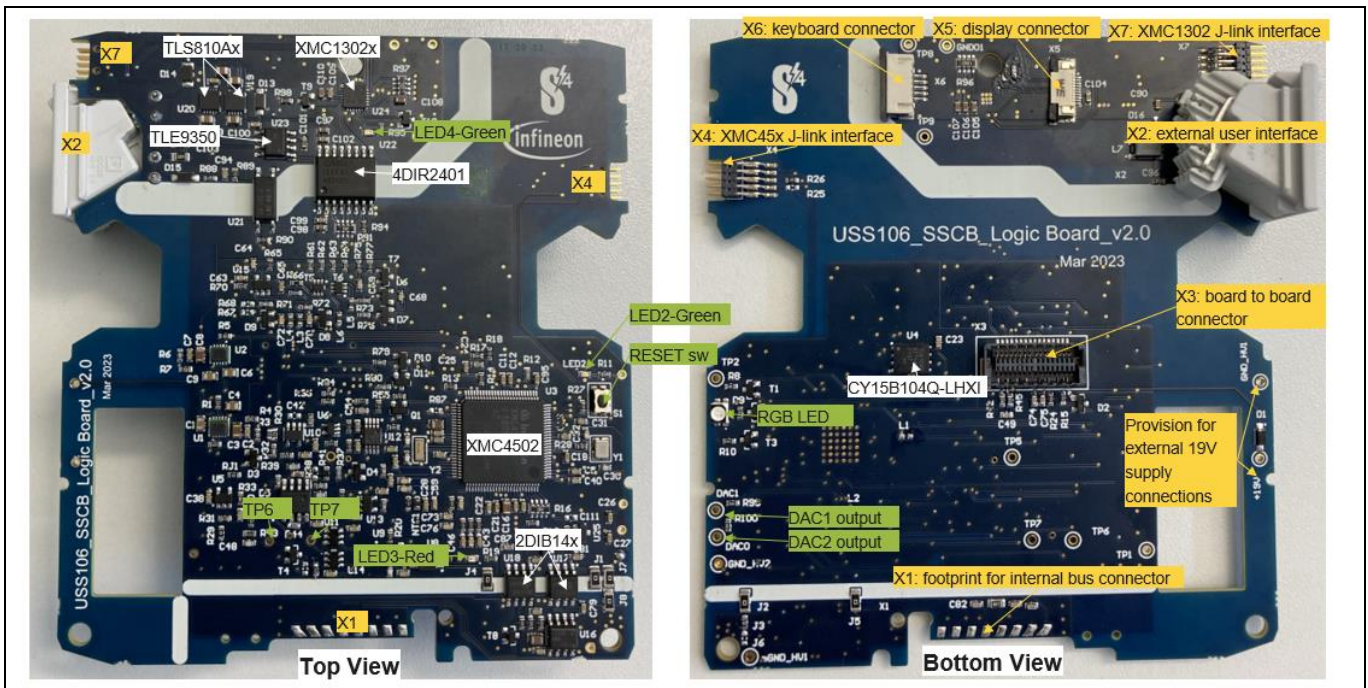

Figure 9 Logic board

SSCB device at a glance

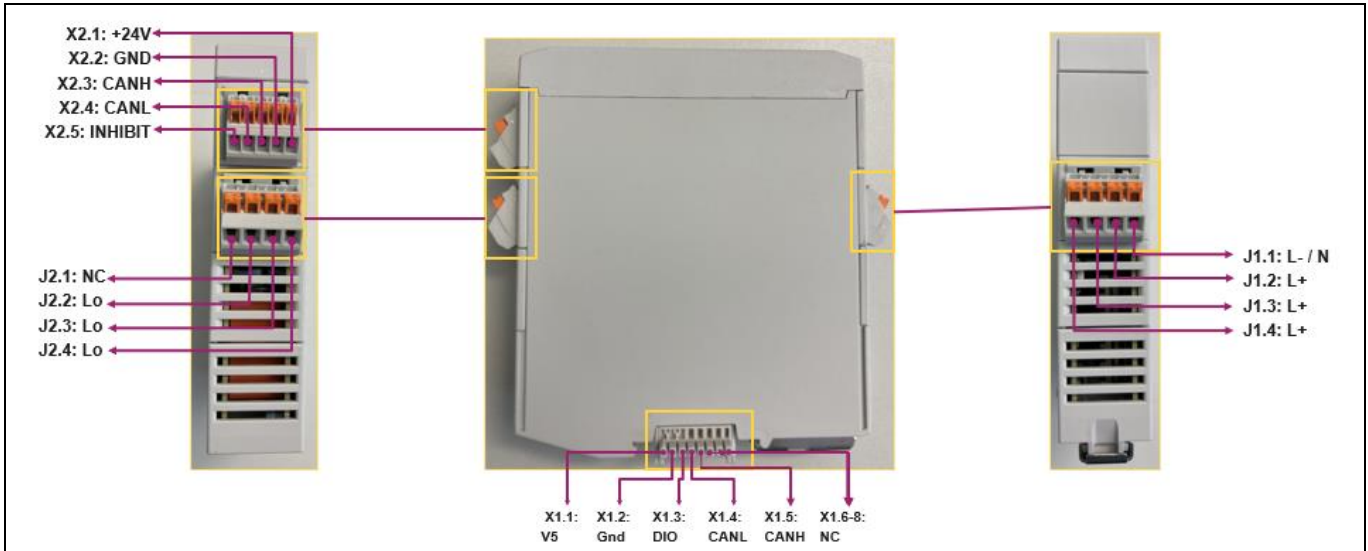

Figure 10 External connector terminal diagram

Table 4 Connector details

Designator	Description	Manufacturer	Mating part
J1	Channel input supply from the grid	Phoenix Contact	1084034
J2	Channel output for load connection	Phoenix Contact	1084034
X1	Internal backplane bus connector	Phoenix Contact	2202891
X2	External user interface bus	Phoenix Contact	1102108
X4	SWD debug connector for XMC4502x	Segger	10-pin J-Link debug cable
X5	TFT display connector	Phoenix Contact	1215686
X6	Keyboard connector	Phoenix Contact	1215683
X7	SWD debug connector for XMC1302x	Segger	10-pin J-Link debug cable

All Phoenix Contact mating parts (Table 4) are provided with the demonstrator kit.

While removing the plastic housing, ensure that you gently unlock the front panel to avoid damage to the keyboard and display connection cables.

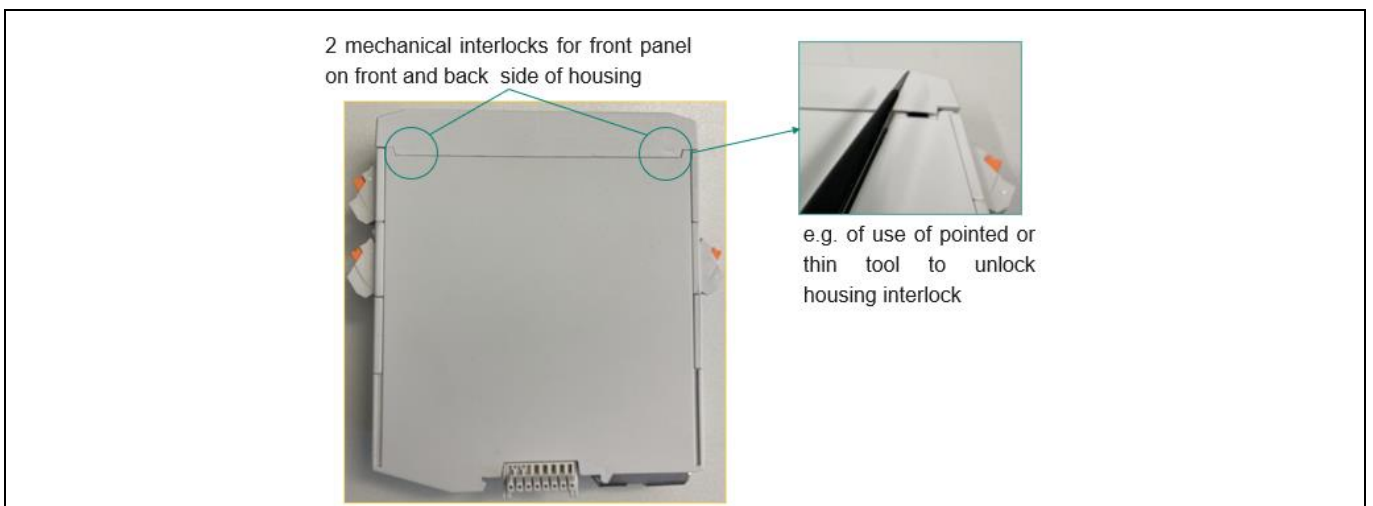

Figure 11 Opening the front panel of the housing

SSCB device at a glance

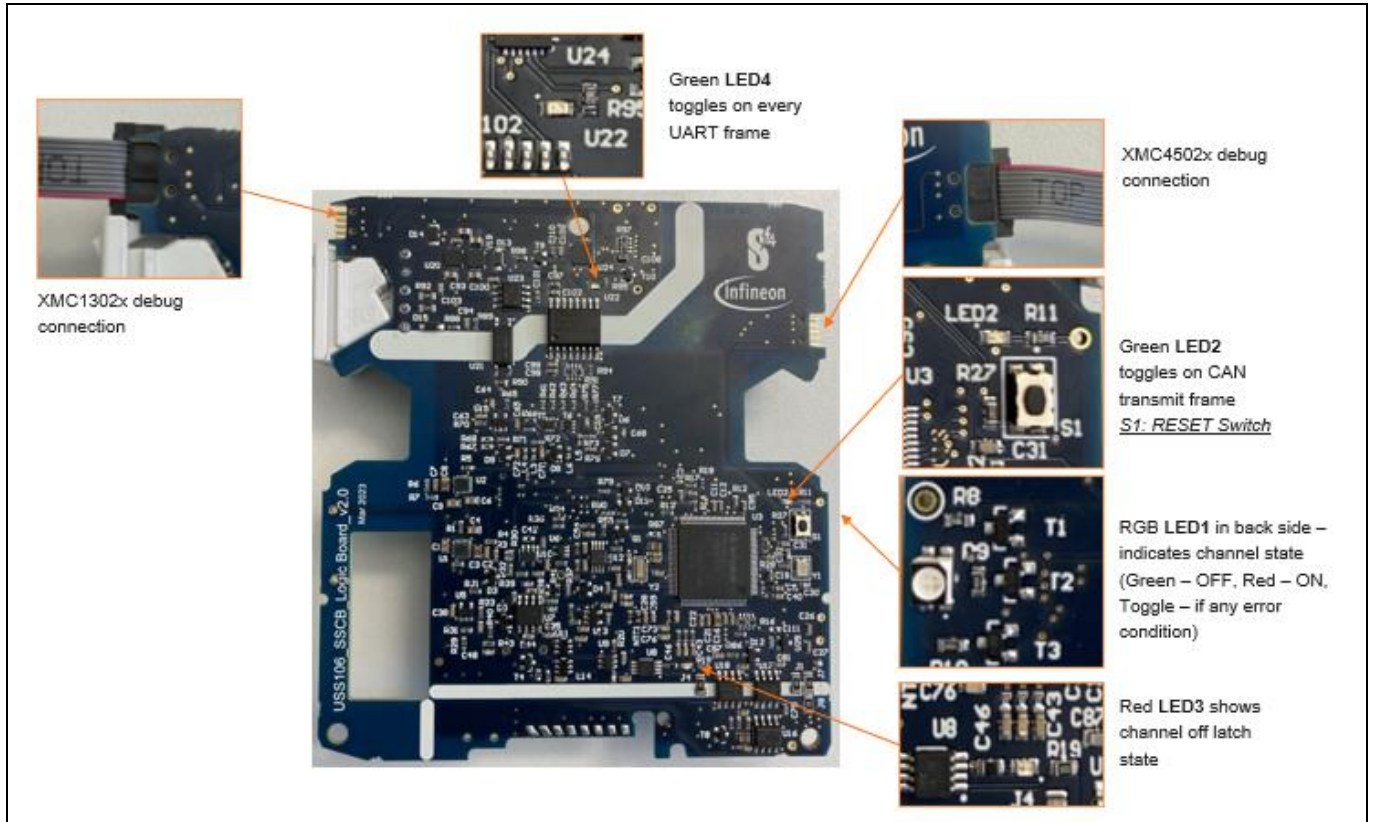

Figure 12 Onboard connections and indications

Table 5 Hardware provisions

Selection	Selection	Board-component	Demo Rev1 software support
1P configuration	Master	Logic board: R12, R58 placed; R56 DNP	Yes
Multichannel configuration	Master	Logic board: R12, R56, JP1-8 placed; JP6, R58 DNP	No
	Slave	Logic board: R12, R58, JP1-8 DNP; R56, JP6 placed	No

Note: The 1P configuration is the default shipping configuration.

Table 6 Onboard test point provisions

Designator	Description
TP1	GND_HV
TP2	LED2 drive output
TP5	Low-gain differential opamp U6 output
TP6	OCD: Fast comparator output
TP7	CH1_ON
DAC0	DAC0 output
DAC1	DAC1 output

SSCB device at a glance

Figure 13 shows the application connection diagram. This reference design is designed to support resistive and inductive loads. To use a multichannel configuration, two SSCB devices can communicate and synchronize using the backplane bus.

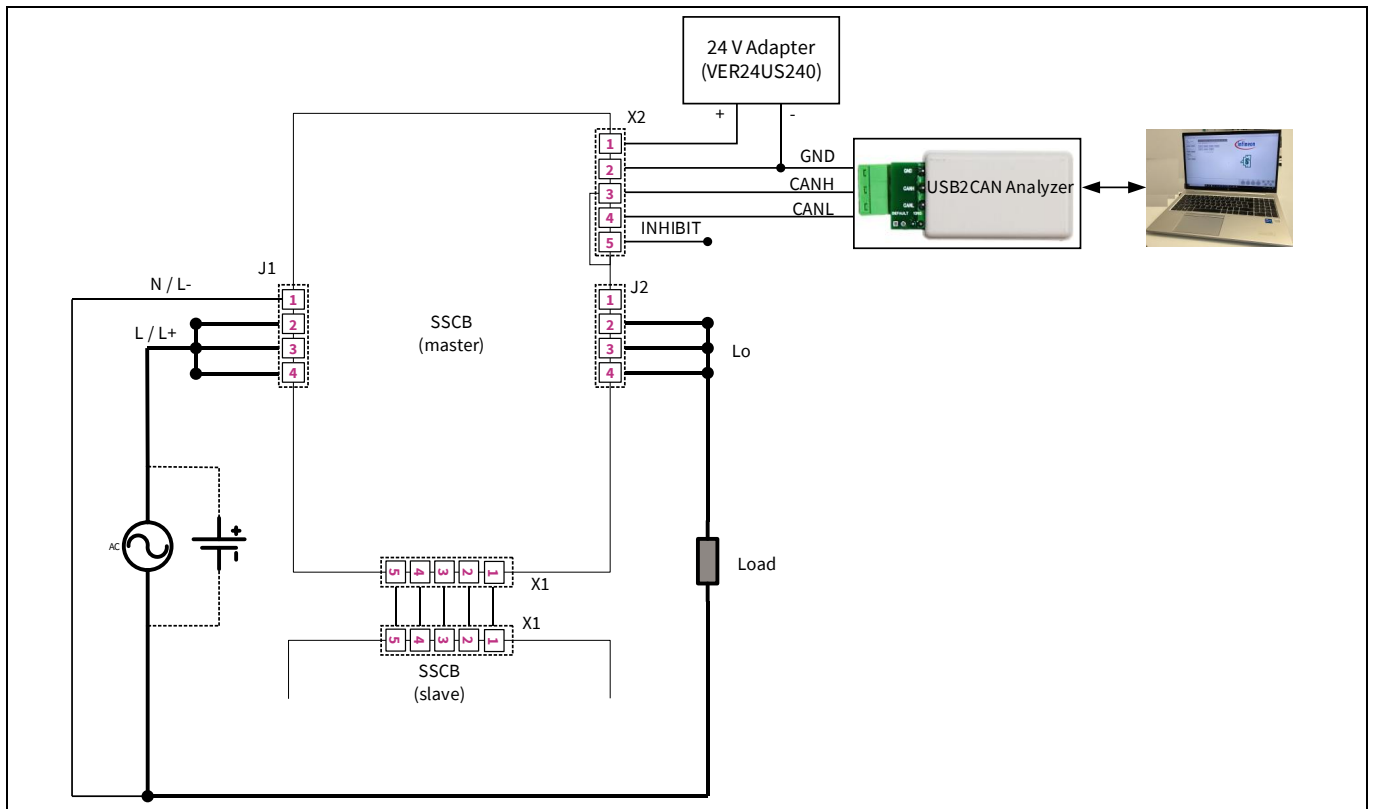

Figure 13 Application connection diagram

SSCB Demo GUI

2 SSCB Demo GUI

The SSCB Demo GUI is programmed to communicate with the demo board over CAN communication. It provides different monitoring and programmability options.

2.1 GUI main window

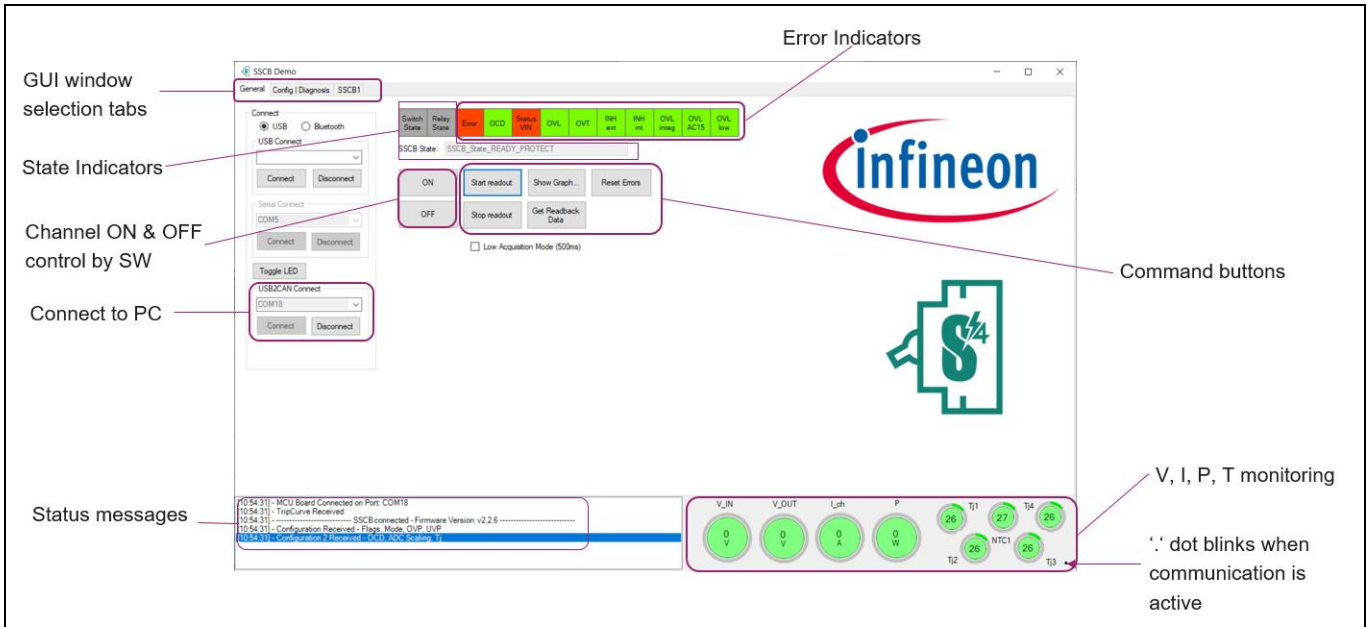

Figure 14 SSCB GUI main window

Table 7 Functions overview of main window

Functions/buttons	Description
Connect/Disconnect	Starts/stops the communication between the SSCB device and GUI
ON/OFF	Turns the channel ON and OFF by using the GUI
Start/Stop readout	Starts and stop periodic status, error, and analog readouts
Show Graph	Shows real-time graph of analog measurements. New window will open.
Low Acquisition mode	When selected, measurements update rate is of 2 Hz; if not, the default is ~200 Hz
Reset Errors	Resets latch error flags if possible and returns the SSCB state to ‘SSCB_State_OFF’
Get Readback Data	One-time status, error, and analog readout
Error/state Indicators	Representation of the status flags (refer Table 8)
V, I, P, T monitoring	Shows channel input and output voltages, current, input power, MOSFET junction temperatures, and NTC based logic board temperature

Table 8 Functions of the error/status indicators

Error/status indicator	Description
Switch State	Current MOSFET switch state. Green: ON; grey: OFF
Relay State	Current safety relay contact state. Green: closed; grey: open
SSCB State	Current SSCB state. To turn ON the channel, it should be in ‘SSCB_State_OFF’ and no error present (refer Table 17)
Error	If any fault/error condition. Red: error; green: normal operation

SSCB Demo GUI

Error/status indicator	Description
OCD	Latched overcurrent status. Red: OCD; green: normal operation
Status VIN	Channel input supply undervoltage or overvoltage status. Red: UVP/OVP; green: normal operation
OVL	Channel overload status. Green: no overload; red: overload (refer Figure 15)
OVT	Any MOSFET overtemperature (OT) protection status. Green: normal condition; red: ($T_j > T_{j_shutdown}$) and resets automatically when ($T_j < T_{j_recovery}$) (refer Figure 17)
INH ext	External INHIBIT input status. Red: active HIGH inhibit; Green: no inhibit signal
INH int	Internal bus DIO status. Red: active LOW DIO signal present; Green: no DIO signal
OVL integ	Different latched overload error flags defined by the tripping chart (refer Figure 15)
OVL AC15	
OVL low	

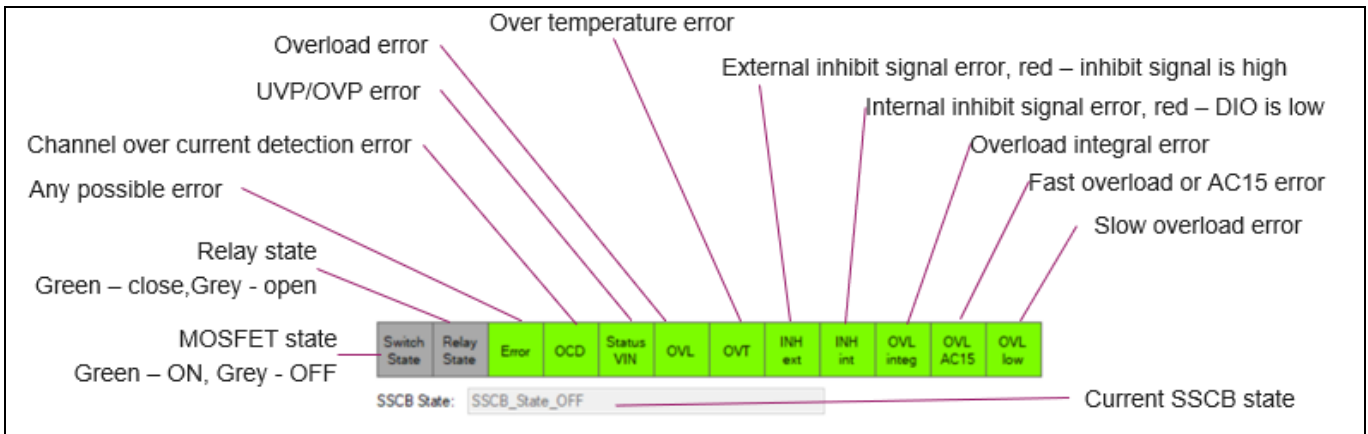

Figure 15 GUI Error/Status indicators

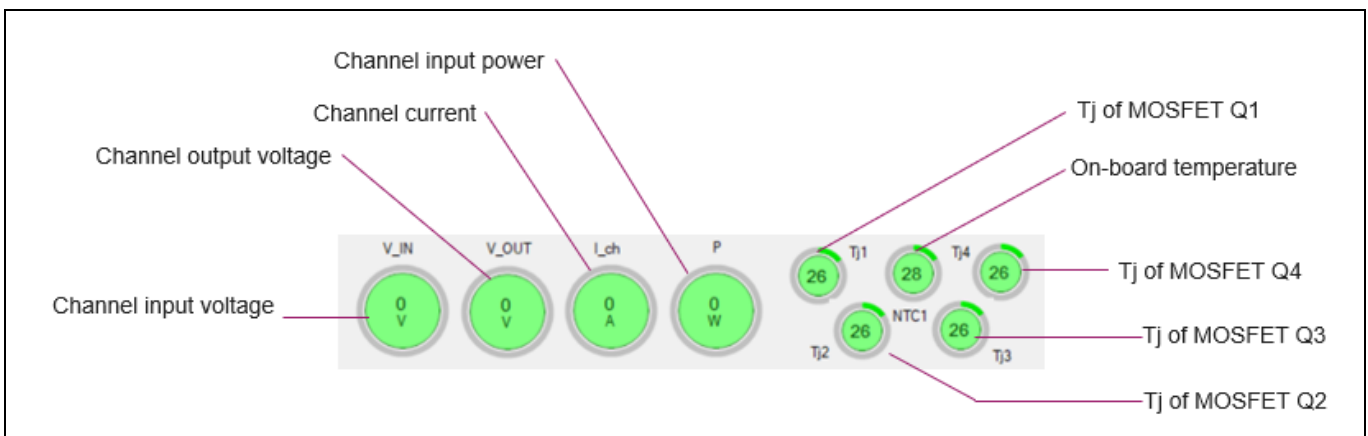

Figure 16 GUI temperature, current, and voltage indicators

SSCB Demo GUI

2.2 GUI configuration window

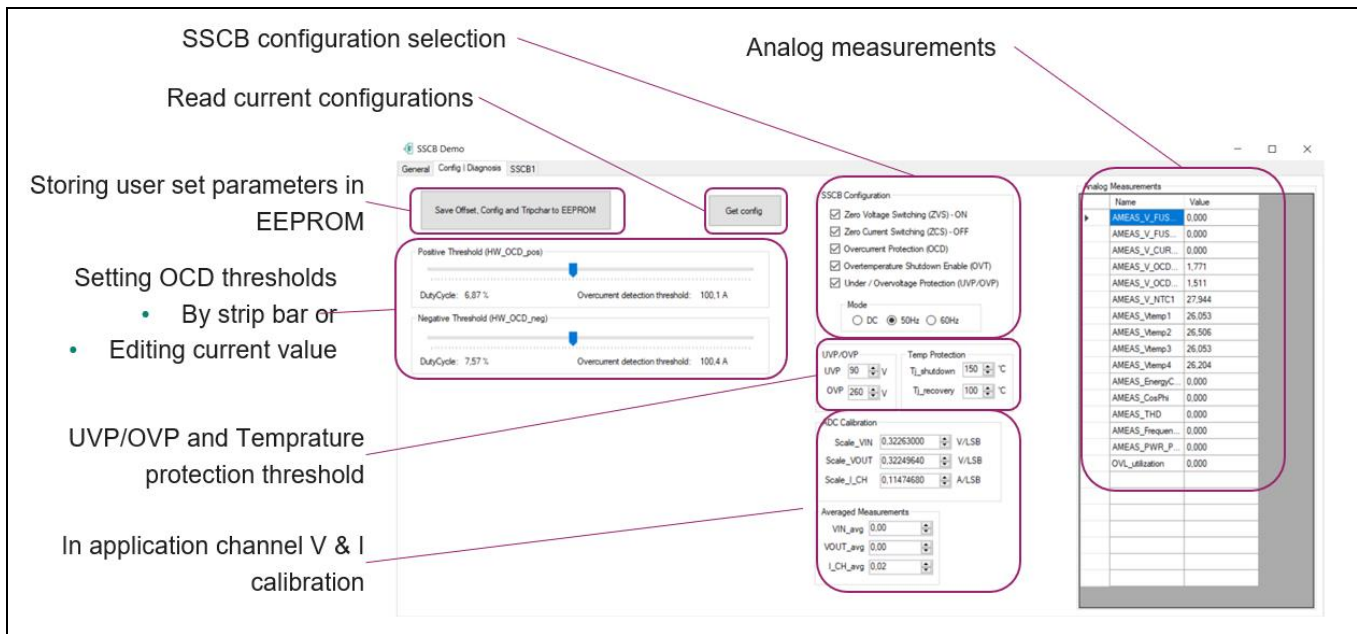

Figure 17 GUI Config|Diagnosis window

Table 9 Config|Diagnosis window parameters

Functions/buttons	Description
Save Offset, Config and Tripchart to EEPROM	Stores the SSCB configuration, +/- OCD, UVP/OVP, temperature protection thresholds, ADC calibration scale factors, and trip chart parameters in the EEPROM as default values after POR
Get config	Reads back the OCD thresholds and SSCB configuration settings loaded in the MCU RAM
Positive threshold	OCD positive threshold limit
Negative threshold	OCD negative threshold limit
SSCB configuration	Provision to select different options and AC/DC channel supply selection <i>Note: Disable ZVS/ZCS during DC mode.</i>
Mode selection	DC or AC (50/60 Hz) channel supply selection
Vin protection	Sets UVP and OVP thresholds. There is fixed 2 V over hysteresis for UVP threshold and 2 V under hysteresis for OVP threshold.
Overtemperature protection	Sets Tj shutdown and recovery thresholds
Analog measurements	Periodic readout of analog measurements (Table 10)
In-application V & I calibration	Provision for in-application calibration of the channel input/output supply and current. Averaged measurements show V and I with 100 samples averaging.

SSCB Demo GUI

2.2.1 SSCB in-application calibration

To achieve a higher measurement accuracy of the channel input, output voltages and current, you can do in-application calibration using the GUI at SSCB nominal ratings. As shown in [Figure 18](#), measure the channel input and output voltages and current by using measuring instruments (such as a DMM) in the channel ON condition.

Calculate new scale factors and replace old scale factors in the GUI. Save all three new scale factors in the EEPROM.

$$Scale_{x_{new}} = Scale_{x_{GUI}} * \frac{x_{DMM}}{x_{avg_{GUI}}}$$

Equation 1

- VIN new scale factor example:

$$Scale_{VIN_{new}} = Scale_{VIN_{old}} * \frac{VIN_{DMM}}{VIN_{avg_{GUI}}}$$

Equation 2

Before saving the new scaling factor to EEPROM during DC measurement, it is recommended to perform first channel 0 V calibration. Follow these steps to calibrate channel 0 V:

1. Keep the channel input and output at 0 V.
2. Power the board with external 19 V supply (refer [Figure 8](#), [Figure 9](#) for 19 V connection provision).
3. Start measurement in AC mode.
4. Issue the command to save in the EEPROM.

SSCB Demo GUI

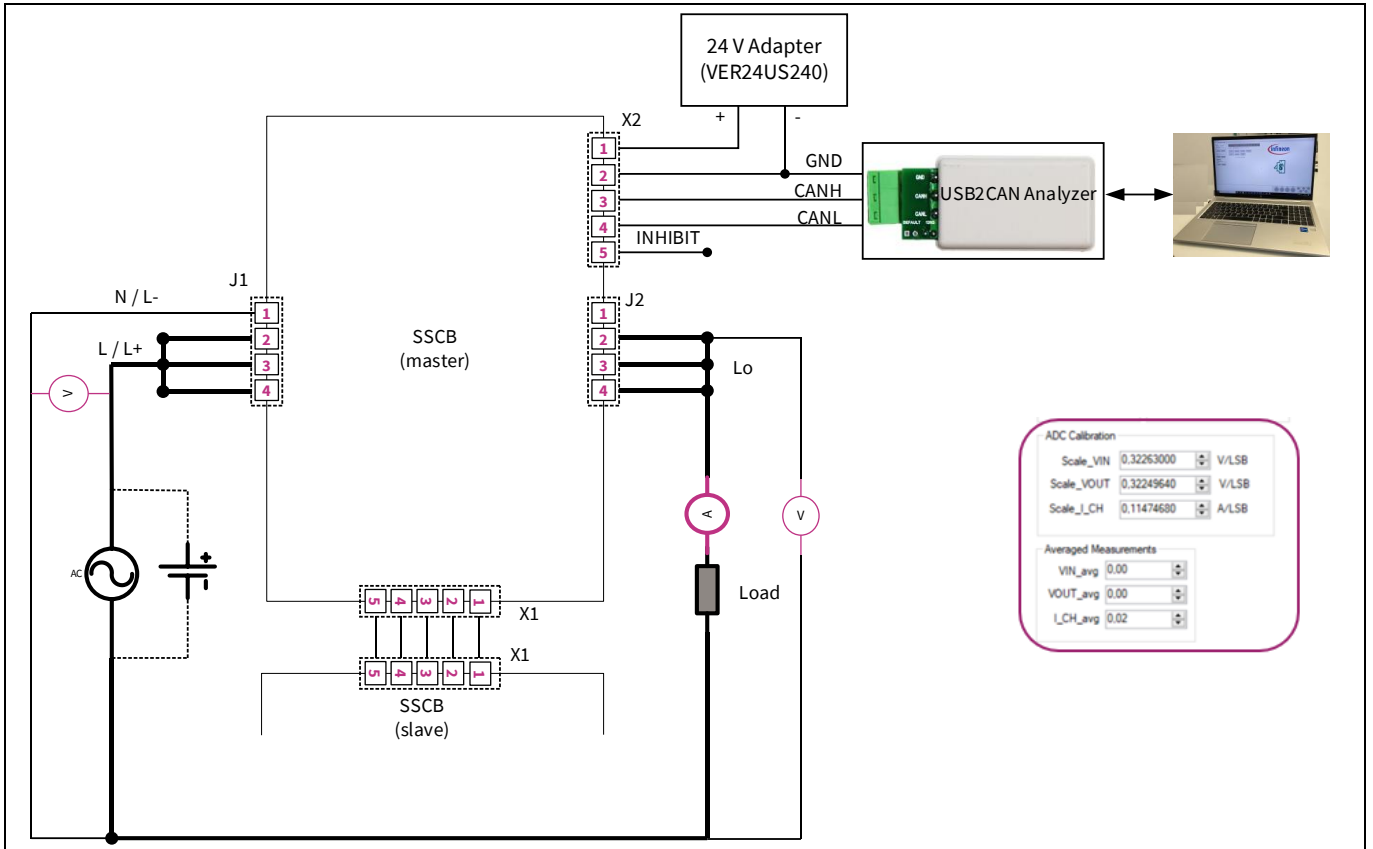

Figure 18 In-application calibration setup

Table 10 Analog measurements

Parameter	Description	Unit
AMEAS_V_FUSE_IN	Channel input RMS voltage readout	V
AMEAS_V_FUSE_OUT	Channel output RMS voltage readout	V
AMEAS_V_CURRENT	Channel RMS current readout (I_ch)	A
AMEAS_V_OCD_thrp_read	OCD positive reference voltage readout	V
AMEAS_V_OCD_thrm_read	OCD negative reference voltage readout	V
AMEAS_V_NTC1	Logic board NTC temperature readout	°C
AMEAS_Vtemp1	MOSFET Q1 junction temperature readout	°C
AMEAS_Vtemp2	MOSFET Q2 junction temperature readout	°C
AMEAS_Vtemp3	MOSFET Q3 junction temperature readout	°C
AMEAS_Vtemp4	MOSFET Q4 junction temperature readout	°C
AMEAS_EnergyCount	Energy measurement (not implemented)	kWh
AMEAS_CosPhi	Power factor in AC grid usage	
AMEAS_THD	Total harmonic distortions (not implemented)	
AMEAS_Frequency	Frequency measurement in AC grid usage	Hz
AMEAS_PWR_Peak	RMS power over 1 cycle for AC grid or 20 ms in DC grid	W
IRMS_utilization	Time required in overload condition until channel switch off	%

SSCB Demo GUI

2.3 GUI trip chart window

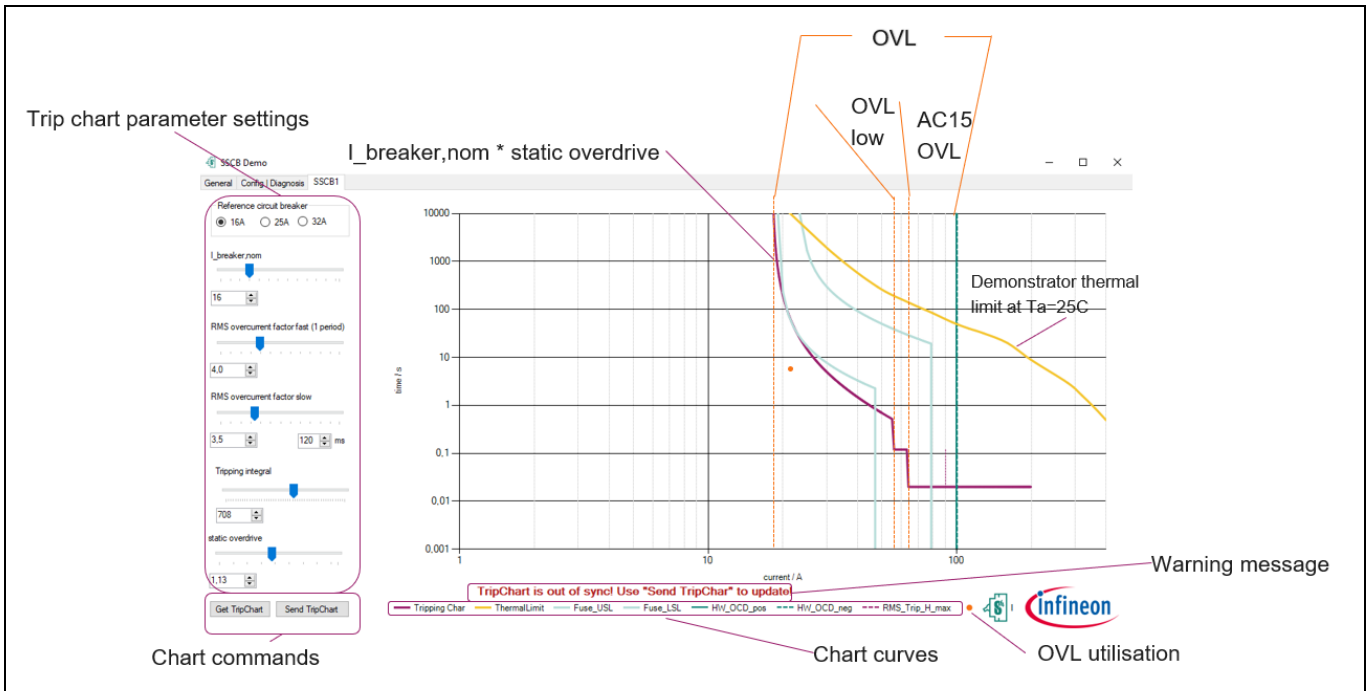

Figure 19 GUI SSCB1 window

Table 11 Functions overview of config/diagnosis window

Function/buttons	Description
Trip chart parameter settings	Parameters for SSCB trip chart (refer Table 12)
Get TripChart	Gets the current trip chart parameters stored in MCU RAM memory
Send TripChart	Sends all trip chart parameters from the GUI to the SSCB
Warning message	Indicates when you change any trip chart parameter; disappears when you click the Send TripChart button.
Chart Curves	Represents curve details available on Time vs. Current logarithmic graph (refer Table 12)

Table 12 Trip parameter/Curves details

Parameter/Curve name	Description
$I_{breaker,nom}$	SSCB nominal current rating
RMS overcurrent factor fast (1 period)	AC15 OVL threshold
RMS overcurrent factor slow	Overcurrent detection threshold with settable detection time
Tripping integral	Defines I^2t limit during overload condition
Static overdrive	Overdrive scaling factor for nominal current
Tripping Char	SSCB tripping boundaries as per user parameters set in the GUI
ThermalLimit	SSCB demonstrator thermal limit at $T_a=25^{\circ}C$
Fuse_USL	Class B tripping characteristics upper set limit
Fuse_LSL	Class B tripping characteristics lower set limit
HW_OCD_pos	Positive OCD threshold

SSCB Demo GUI

Parameter/Curve name	Description
HW_OCD_neg	Negative OCD threshold
RMS_Trip_H_max	Maximum peak current limit of RMS overcurrent factor fast, 1.43 times

2.3.1 SSCB overload errors

There are four types of overload errors in SSCB: OVL, OVL integ, OVL low, and AC15 OVL.

- OVL: Error remains active as long as I_{ch} is above $(I_{breaker,nom} * \text{Static overdrive})$.
- OVL integ: Latched error flag set when tripping integral level reaches overload condition. Time to switch off channel during OVL integ is calculated as:

$$Time = \frac{Tripping\ integral}{(I_{ch} - I_{breaker,nom} * \text{Static overdrive})^2} \text{ seconds}$$

Equation 3

You can monitor I_{ch} and time using ‘Show Graph window’ of the Demo tool or using oscilloscope; see [Figure 20](#) test.

- OVL low: Latched error flag sets when I_{ch} is above the RMS overcurrent factor slow for set time. In AC system, the number of cycles to switch off the channel can be calculated as $(set_time * frequency + 0.5 \text{ or } 1)$, refer [Figure 21](#) test.
- AC15 OVL: Latched error flag sets when I_{ch} is above the RMS overcurrent factor fast threshold for 1.5 or 2 cycles in AC and 30-40ms in DC system; see [Figure 22](#) test.

In AC system, the channel switches off at ZCS if any latched overload error triggers.

SSCB Demo GUI



Figure 20 OVL integ test

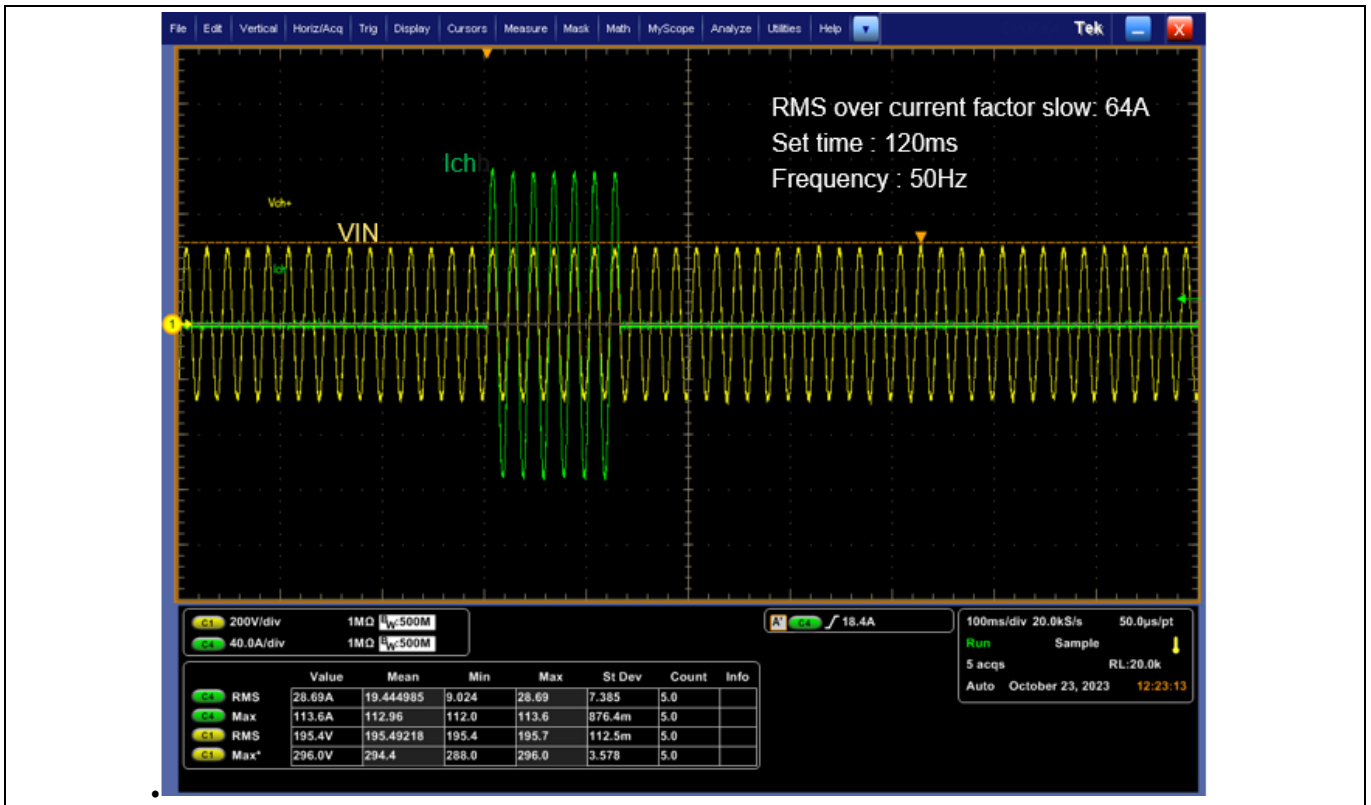

Figure 21 OVL low test

SSCB Demo GUI

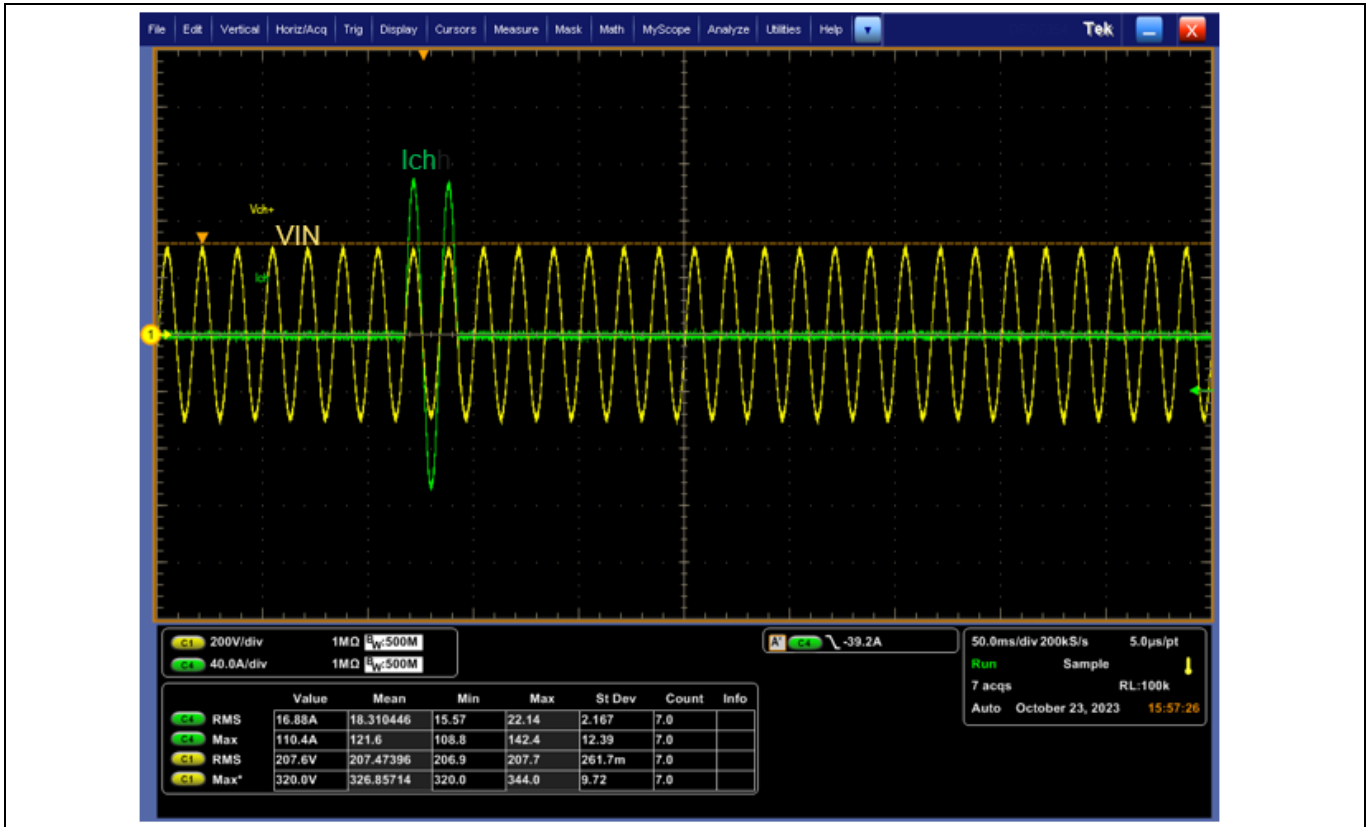

Figure 22 AC15 OVL test

2.4 GUI real-time graph window

With the periodic readout starts in the main window, all analog measurements are displayed in the real-time graph window with an update rate of either ~200 Hz or 2 Hz (depending on the selection in the main window). All data are saved regardless of whether the channel is activated, and can only be cleared by clicking the “Clear Chart” button. Figure 23 shows the real-time graph window.

In addition to the analog signals, all status flags also can be displayed. By default, all previous data is shown, but there is an option to either enable roll-mode which displays and save data from the last 10 s or AutoClear which only displays the last 1000 data points.

When exporting data to a *.csv file, only the selected channels will be exported. For long duration data recording, you can use the continuous *.csv download option. Long duration data recording is preferable in slow acquisition mode to keep the PC loading lower.

SSCB Demo GUI

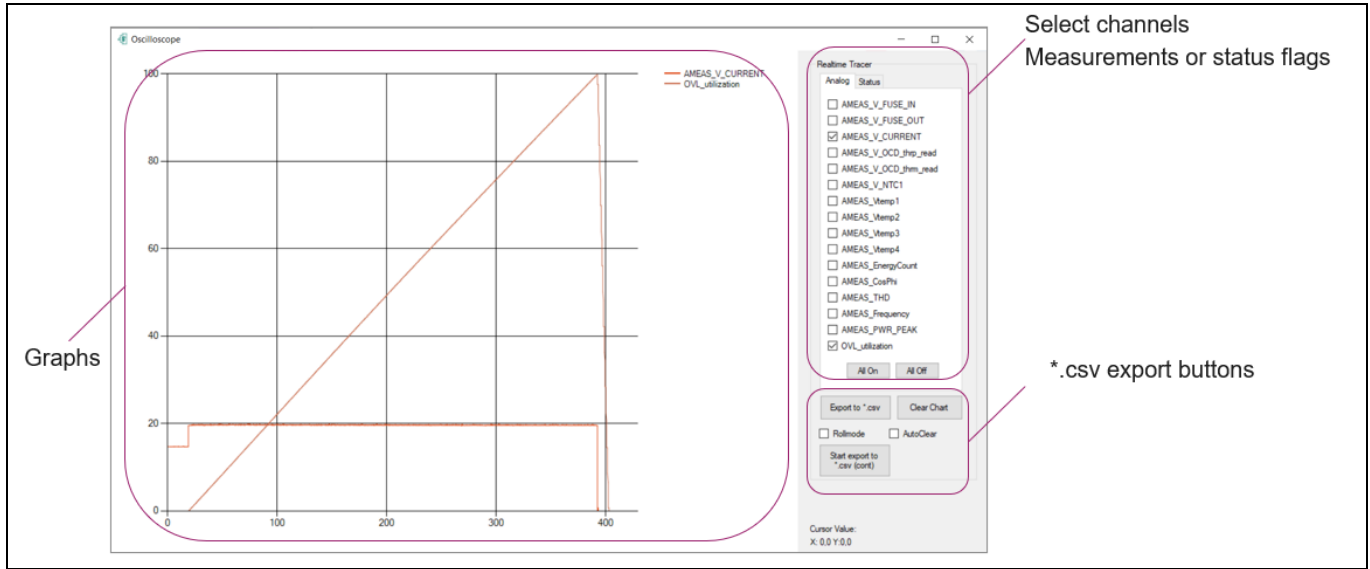

Figure 23 Real-time graph window

SSCB front panel

3 SSCB front panel

The SSCB front panel has a TFT display and keyboard. The display has five screens, which can be selected by keyboard.

- Page 1: Power, input voltage, channel current, and frequency measurements.
- Page 2: All four MOSFET T_j and onboard NTC measurements in degree Celsius.
- Pages 3 and 4: MOSFET and relay status along with error flags.
- Page 5: Hardware and software version details.

Bottom of each page shows SSCB state.

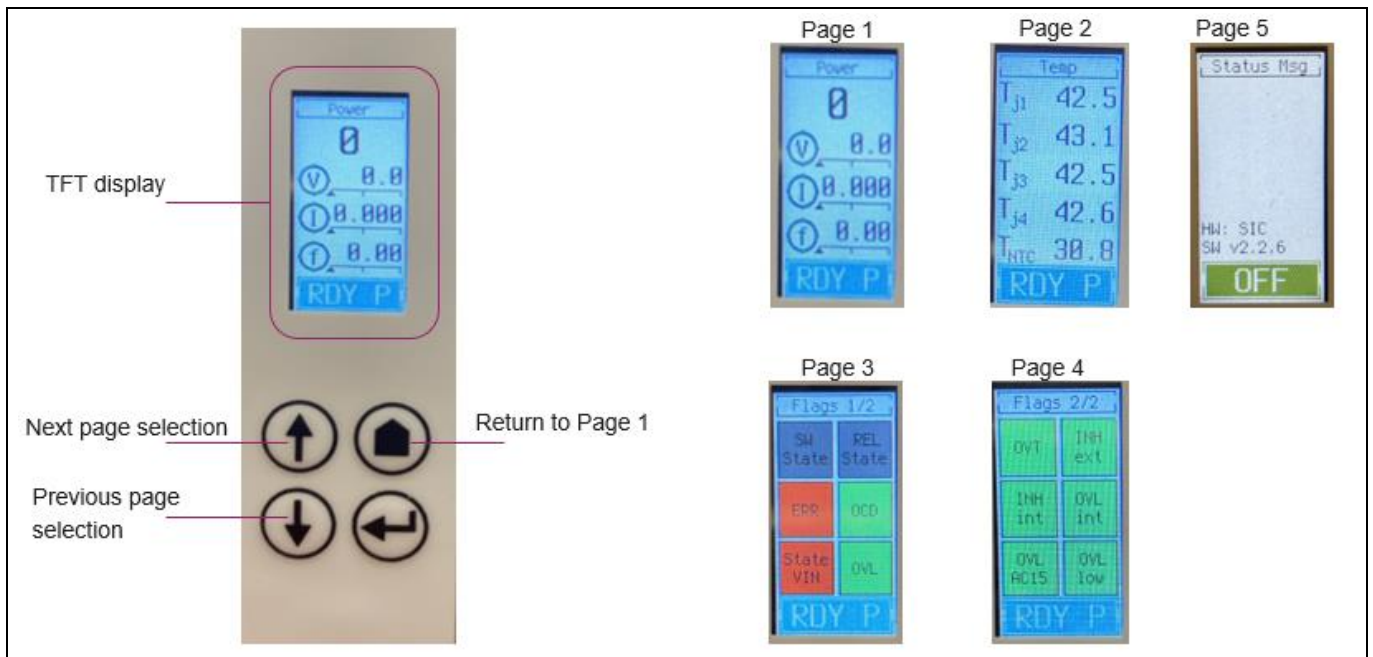

Figure 24 Front panel details

Getting started

4 Getting started

The basic setup to start the SSCB demonstrator is shown in [Figure 13](#). Slave connection is not required for 1 pole (1P) configuration.

Do the following to get demonstrator running:

1. Install the USB driver (CH341SER.exe) of USB2CAN analyzer provided in the GUI zip folder (Required only for the first time).
2. Turn on the SSCB channel supply and 24 V adapter supply.
3. Display starts showing the channel supply measurements. RGB LED1 turns green (illumination visible near connector J1). Onboard, the green LED4 starts blinking, red LED3 turns ON (see [Figure 12](#) for LED locations).
4. Open the SSCB Demo GUI application and select the assigned COM port to connect.
5. Successful connection with GUI shows status messages as shown in [Figure 25](#).
6. With the periodic start readout command, the onboard green LED2 and '.' in the right bottom corner of the GUI main window start blinking (refer [Figure 14](#)). The GUI starts displaying periodic readouts.
7. SSCB demonstrator is ready for user.

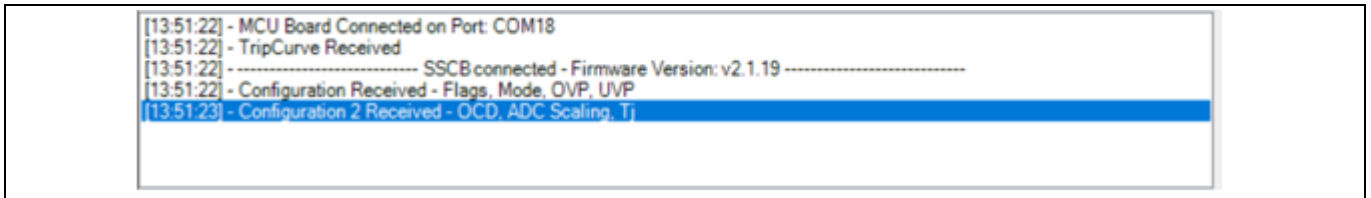

Figure 25 GUI status message on successful connection

To get flexibility in development stage, you can use an external 19 V DC (+/-1 V) supply either on the logic or power board to test the demonstrator at lower channel voltages. While using this provision, place JP1 on the power board and disable UVP/OVP protection in the GUI.

Note: The safety relay is designed for 16 A RMS only. The application settings allow to exceed this current capability; if such a setup is selected, the relay must be bypassed by creating an external low-impedance short across the relay contacts on the power PCB.

CAN communication

5 CAN communication

5.1 Communication interface

The SSCB demonstrator uses a CAN interface for communication between the PC GUI and the demo boards via a galvanically isolated CAN interface. The specifications for the CAN interface are shown in [Table 13](#) and [Figure 26](#).

Table 13 CAN configuration of mainboard

Setting	Value
CAN version	V2.0B active
Identifier	Standard 11-bit
RX identifier address	0x321
TX identifier address	0x321
Data length (RX & TX)	8 bytes
Baud rate	500 kbps

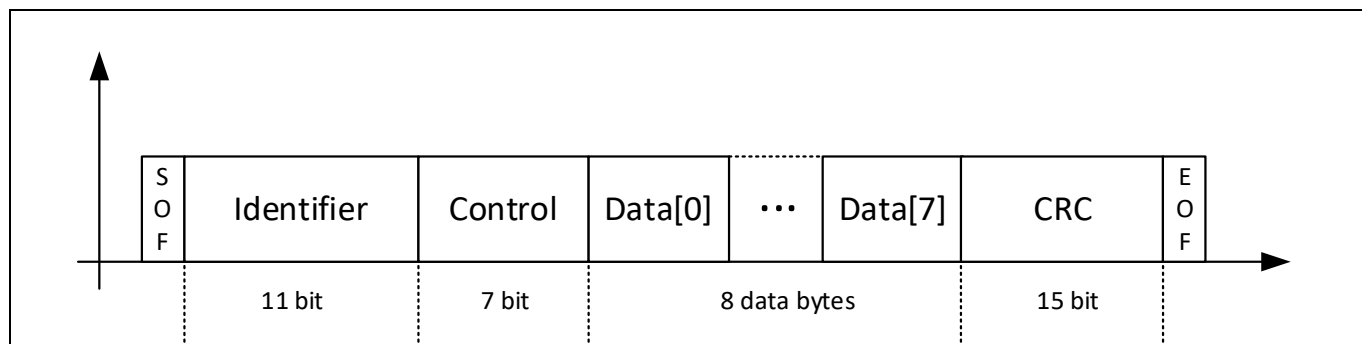

Figure 26 CAN frame structure for communication

CAN communication

5.1.1 CAN command list

Return data for each command will be returned with the following CAN command. Each CAN frame width is 8 bytes.

Table 14 CAN Rx – receive data

Command	Byte number	Data	Description
SWITCH_ON	0	0x01	Turn SSCB switch on
SWITCH_OFF	0	0x02	Turn SSCB switch off
SWITCH_IDLE	0	0x0B	Turn SSCB switch to idle
START_READOUT	0	0x06	Initiate status feedback from SSCB (all status frames)
EEPROM_WRITE	0	0x0C	Write configuration and current offset values into EEPROM
SWITCH_RESET	0	0x0D	SSCB reset errors
SET_OCD_LVL	0	0x0E	Set OCD threshold
	1	<var>	Negative OCD threshold output PWM duty cycle HIGH byte
	2	<var>	Negative OCD threshold output PWM duty cycle LOW byte
	3	<var>	Positive OCD threshold output PWM duty cycle HIGH byte
	4	<var>	Positive OCD threshold output PWM duty cycle LOW byte
SET_TRIP_CURVE	0	0x0F	Set SSCB trip curve
	1	<var>	SSCB nominal current
	2	<var>	RMS_trip_factor_low
	3	<var>	T_overdrive
	4	<var>	RMS_trip_factor_high
	5	<var>	OVL_integ HIGH byte
	6	<var>	OVL_integ LOW byte
	7	<var>	Static overdrive factor
SET_CONFIG	0	0x10	Set SSCB configuration 1
	1	<var>	SSCB config flags (See Table 16)
SET_CONFIG2	0	0x11	Set SSCB configuration 2
	1	<var>	SCALE_VIN – byte 0 (float)
	2	<var>	SCALE_VIN – byte 1 (float)
	3	<var>	SCALE_VIN – byte 2 (float)
	4	<var>	SCALE_VIN – byte 3 (float)
	5	<var>	TJ_SHUTDOWN
	6	<var>	TJ_RECOVERY
	7	<var>	SCALE_VOUT – byte 0 (float)
SET_CONFIG3	0	0x12	Set SSCB configuration 3

CAN communication

Command	Byte number	Data	Description
	1	<var>	SCALE_CURR – byte 0 (float)
	2	<var>	SCALE_CURR – byte 1 (float)
	3	<var>	SCALE_CURR – byte 2 (float)
	4	<var>	SCALE_CURR – byte 3 (float)
	5	<var>	SCALE_VOUT – byte 1 (float)
	6	<var>	SCALE_VOUT – byte 2 (float)
	7	<var>	SCALE_VOUT – byte 3 (float)
SET_CONFIG4	0	0x19	Set SSCB configuration 4
	1	<var>	Undervoltage protection limit HIGH byte
	2	<var>	Undervoltage protection limit LOW byte
	3	<var>	Overvoltage protection limit HIGH byte
	4	<var>	Overvoltage protection limit LOW byte
GET_TRIP_CURVE	0	0x13	Initiate trip curve readout from SSCB
GET_CONFIG	0	0x14	Initiate config readout from SSCB (Version frame + all config frames)
BLD_INIT	0	0x1A	Reset MCU in bootloader mode for firmware update via CAN

Table 15 CAN TX transmit data

Command	Byte number	Data	Description
ADC_DATA	0	0x04	Status feedback frame
	1	0x00	Frame number
	2-3	<var>	Status bytes 0 – 1 (see Table 17)
	4-5	<var>	V_FUSE_IN
	6-7	<var>	V_FUSE_OUT
ADC_DATA	0	0x04	Status feedback frame
	1	0x01	Frame number
	2-3	<var>	V_CURRENT
	4-5	<var>	V_OCD_thrp
	6-7	<var>	V_OCD_thrm
ADC_DATA	0	0x04	Status feedback frame
	1	0x02	Frame number
	2-3	<var>	V_NTC
	4-5	<var>	Vtemp1
	6-7	<var>	Vtemp3
ADC_DATA	0	0x04	Status feedback frame
	1	0x03	Frame number
	2-3	<var>	EnergyCount
	4-5	<var>	CosPhi

CAN communication

Command	Byte number	Data	Description
	6-7	<var>	THD
ADC_DATA	0	0x04	Status feedback frame
	1	0x04	Frame number
	2-3	<var>	Frequency
	4-5	<var>	PWR_PEAK
	6-7	<var>	Status bytes 2-3 (see Table 17)
ADC_DATA	0	0x04	Status feedback frame
	1	0x05	Frame number
	2-3	<var>	Vtemp3
	4-5	<var>	Vtemp4
	6-7	<var>	OVL_utilization
GET_TRIP_CURVE	0	0x13	Trip curve frame
	1	<var>	Nominal current
	2	<var>	RMS_trip_factor_low
	3	<var>	T_overdrive
	4	<var>	RMS_trip_factor_high
	5-6	<var>	OVL_integ
	7	<var>	Static overdrive factor
GET_CONFIG	0	0x14	Get SSCB Configuration 1
	1	<var>	SSCB config flags (See Table 16)
	2	<var>	Undervoltage protection limit LOW byte
	3	<var>	Undervoltage protection limit HIGH byte
	4	<var>	Overvoltage protection limit LOW byte
	5	<var>	Overvoltage protection limit HIGH byte
GET_CONFIG2	0	0x15	Get SSCB configuration 2
	1	<var>	SCALE_VIN - byte 0 (float)
	2	<var>	SCALE_VIN - byte 1 (float)
	3	<var>	SCALE_VIN - byte 2 (float)
	4	<var>	SCALE_VIN - byte 3 (float)
	5	<var>	TJ_SHUTDOWN
	6	<var>	TJ_RECOVERY
	7	<var>	SCALE_VOUT - byte 0 (float)
GET_CONFIG3	0	0x16	Get SSCB Configuration 3
	1	<var>	SCALE_CURR - byte 0 (float)
	2	<var>	SCALE_CURR - byte 1 (float)
	3	<var>	SCALE_CURR - byte 2 (float)
	4	<var>	SCALE_CURR - byte 3 (float)
	5	<var>	SCALE_VOUT - byte 1 (float)
	6	<var>	SCALE_VOUT - byte 2 (float)

CAN communication

Command	Byte number	Data	Description
	7	<var>	SCALE_VOUT - byte 3 (float)
GET_CONFIG4	0	0x18	Get SSCB Configuration 4
	1	<var>	Negative OCD level LOW byte
	2	<var>	Negative OCD level HIGH byte
	3	<var>	Positive OCD level LOW byte
	4	<var>	Positive OCD level HIGH byte
GET_VERSION	0	0x17	Get SSCB version
	1	<var>	SW VERSION
	2	<var>	SW MAINVERSION
	3	<var>	SW SUBVERSION
	4	<var>	HW_REVISION

Table 16 SSCB configuration flags description

Bit number	Name	Description
0	ZVS_en	Zero voltage switch on enable
1	ZCD_en	Zero current switch off enable
2	OCD_en	Hardware OCD enable
3	OVT_en	Overtemperature protection enable
4	DC_mode	SSCB in DC mode enable
5	AC_60Hz	SSCB 60 Hz AC mode enable
6	OVP_UVP_en	Overvoltage/undervoltage protection enable

CAN communication

Table 17 SSCB Status Feedback flags description

Bit number	Name	Description
0 - 4	SSCB State	SSCB state of operation: 0 ... DOWN 1 ... BIST 2 ... STARTUP 3 ... FAILURE 4 ... OFF 5 ... IDLE 6 ... SYNC 7 ... ON 8 ... ZCD 9 ... ZCD_PROTECT 10 ... IDLE_PROTECT 11 ... OFF_PROTECT 12 ... READY_PROTECT 13 ... FAILURE_SOFT 14 ... FAILURE_CRITICAL 15 ... ZCD_FAILURE 16 ... IDLE_FAILURE
5	SwitchState	MOSFET switch state
6	MSwitchState	Relay state
7	Error	Error indication
8	OCD	OCD error flag
9	StatusVIN	VIN error flag
10	OVL	Overload error flag
11	OVT	Overtemperature error flag
12	INH_ext	External INH line state
13	INH_int	Internal (backplane) INH line state
14	OVL_integ	Integral overload detection flag
15	OVL_AC15	AC15 overload detection flag
16	OVL_low	Slow overload detection flag
17	OVL_Cool	Cooldown after overload indication flag

Table 18 Analog values conversion factors

Parameter ADC value	Factor
General	$V_{ADC} = ADC_{value} * \frac{3.25}{4096}$
IRMS_utilization or OVL_utilization (%)	$IRMS_{utilization} = I^2t * \frac{100}{set_I^2t}$
T _j measurement	$T_j = -190.07m * calc + 398.56m$ $calc (V) = ADC_{value} * \frac{3.25}{4096}$
NTC measurement	As per NTC lookup table

CAN communication

Parameter ADC value	Factor
OCD duty cycle values	$DC[\%] = \frac{DC_val}{100}$
RMS_trip_factor_low, RMS_trip_factor_high	$TripVal[A] = \frac{Reg_val}{10}$
Static overdrive factor	$OverdriverFac = \frac{Reg_val}{100}$
T_overdrive	$T_{overdrive} = Reg_{val} * 20\ ms$ in 50 Hz mode $T_{overdrive} = Reg_{val} * 16.666\ ms$ in 60 Hz mode $T_{overdrive} = Reg_{val} * 20\ ms$ in DC mode
Under-/overvoltage Protection limit	$Limit[V] = \frac{Reg_val}{100}$
AMEAS_V_FUSE_IN	$V_{in}[V] = \frac{AMEAS_V_FUSE_IN}{100}$
AMEAS_V_FUSE_OUT	$V_{out}[V] = \frac{AMEAS_V_FUSE_OUT}{100}$
AMEAS_V_CURRENT	$I_{out}[A] = \frac{AMEAS_V_CURRENT}{100}$
AMEAS_V_OCD_thr	$V_{OCD,thr}[V] = AMEAS_V_OCD_thr * \frac{3.3\ V}{4096}$
AMEAS_CosPhi	$\cos \varphi = \frac{2 \cdot \pi}{8000}$ $\frac{AMEAS_cosphi}{}$
AMEAS_Frequency	$f[Hz] = \frac{1\ 000\ 000}{AMEAS_Frequency}$

SSCB Demo performance test

6 SSCB Demo performance test

6.1 ZVS and ZCS in AC SSCB

In AC mode, the channel switches ON at zero voltage and turns off at zero current level as shown in [Figure 27](#) and [Figure 28](#).

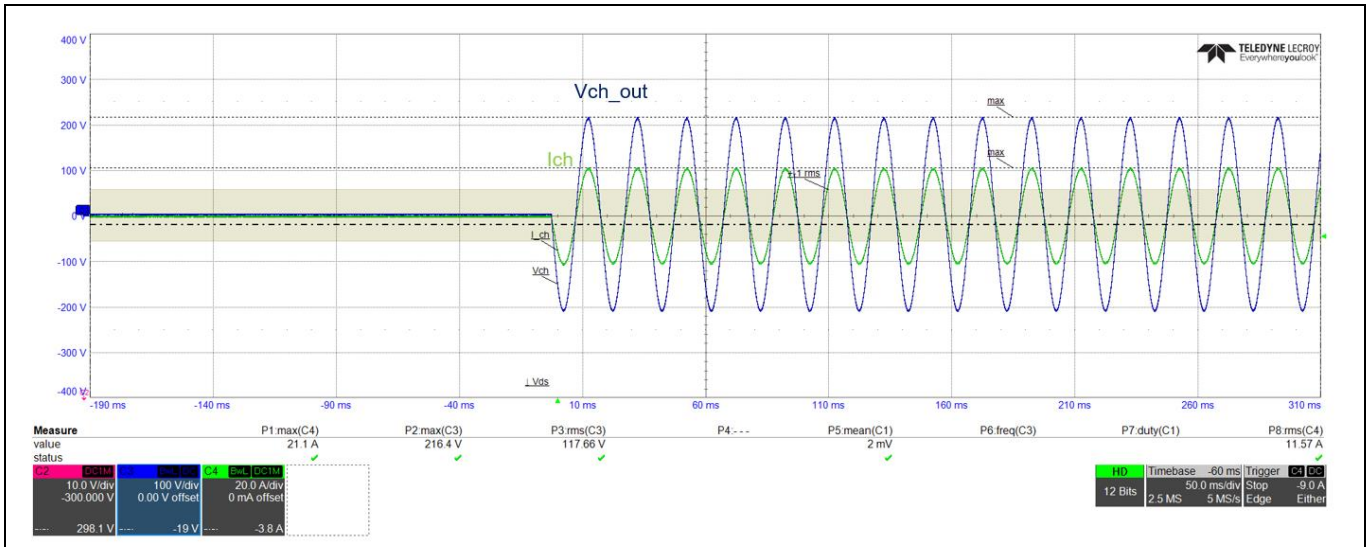

Figure 27 ZVS event

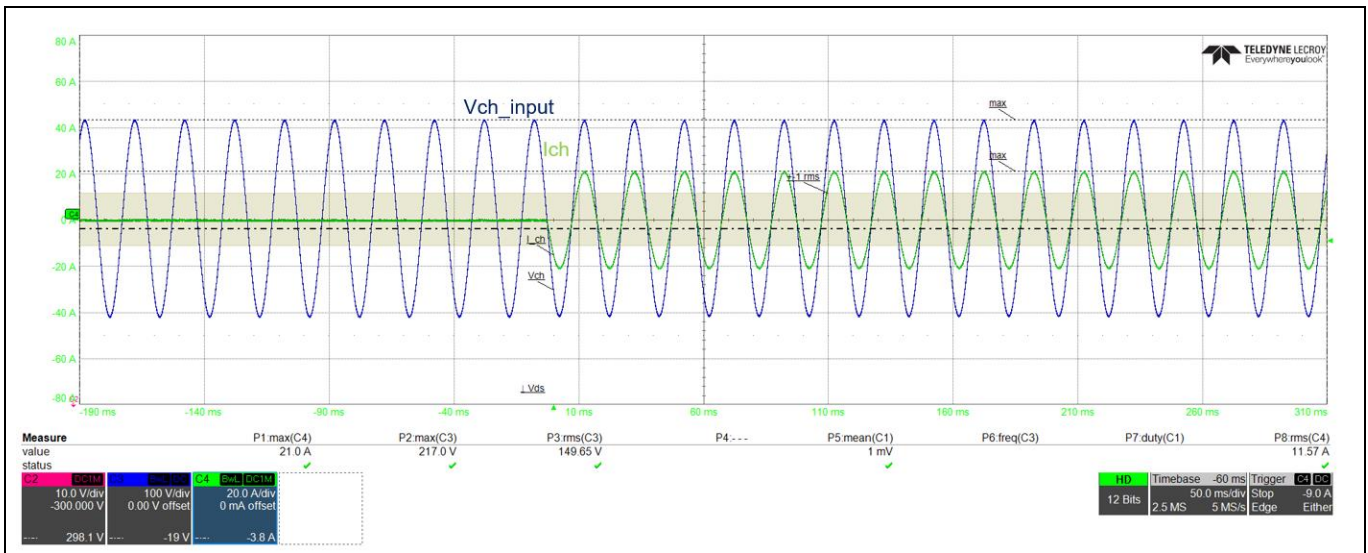

Figure 28 ZCS event

SSCB Demo performance test

6.2 OCD performance

Overcurrent detection (OCD) characteristics are observed for positive and negative channel DC currents as shown in Figure 29. di/dt was limited by wire harness impedance. External switch was used as safety switch to create 200 μs short-circuit pulse in the channel ON condition to avoid capacitor full discharge in case of any failure. The DC supply amplitude changed up to 375 V DC to achieve a different di/dt . As shown in Figure 31, di/dt is tested above 100 A/ μs . I_{trip} is the actual detection threshold and I_{off} is the actual turn-off current due to the MOSFET switch off propagation delay. The Propagation delay is observed around 880 ns with $R_{g_off}=10$ ohm and external $C_{gs}=22$ nF.

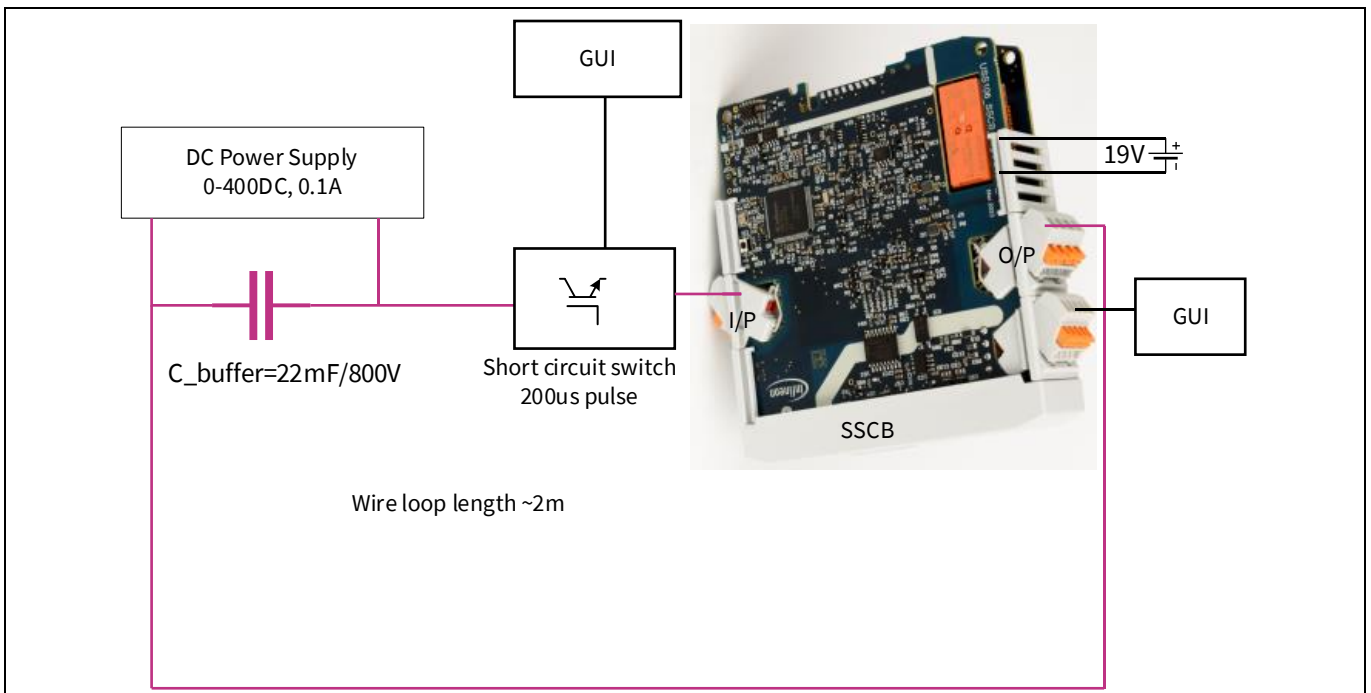

Figure 29 OCD vs. di/dt test setup

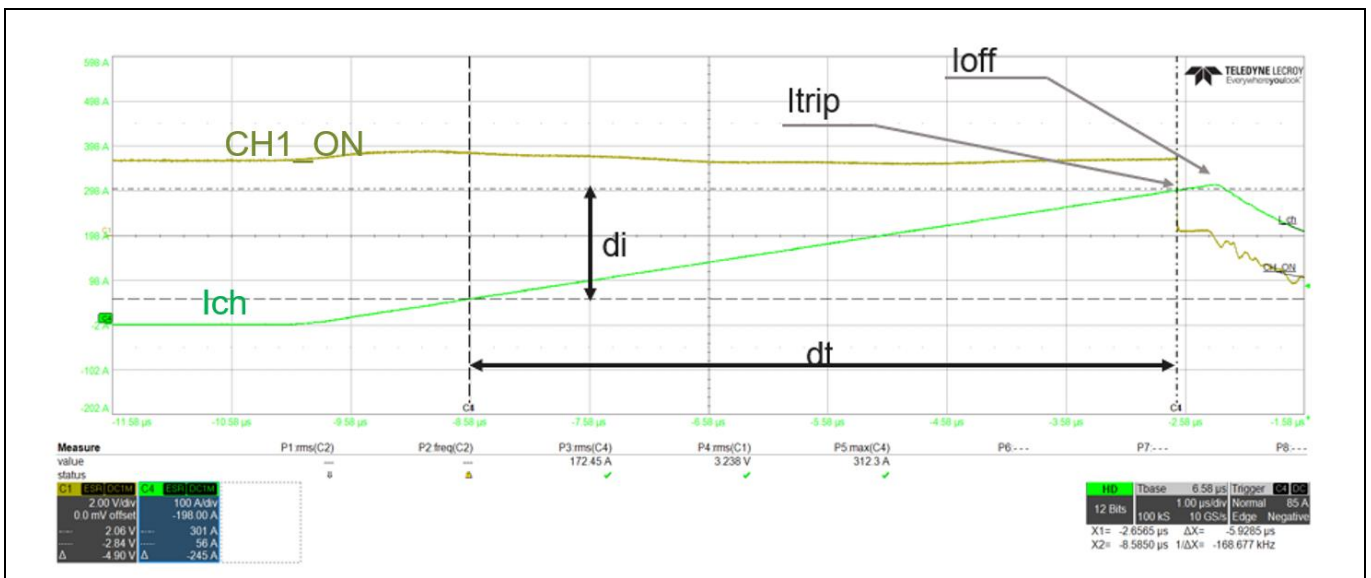

Figure 30 di/dt definition

SSCB Demo performance test

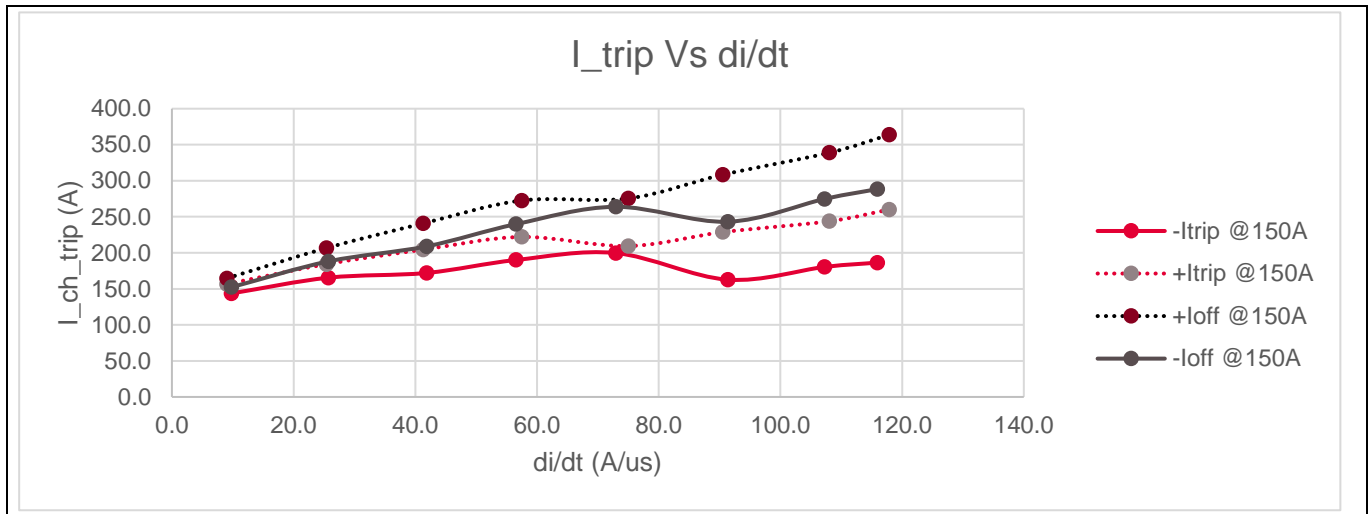

Figure 31 OCD vs. di/dt

6.3 Thermal performance

SSCB uses passive cooling with a Cu heatsink soldered over the QDPAK (PG-HDSOP-22) MOSFET top. After placing SSCB boards in a plastic housing, horizontally placed on tabletop, thermal measurements were done for different DC currents at room temperature. DC power supply was connected across the channel input and output terminals in constant current mode at lower voltages. CoolMOS™ S7T readings were captured using SSCB GUI. Overtemperature protection kept at $T_j=150^{\circ}\text{C}$ to protect MOSFETs during these test observations. From these observations, the thermal tripping characteristics limit is defined.

Note: The safety relay is designed for 16 A RMS only. The application settings allow to exceed this current capability; if such a setup is selected, the relay must be bypassed by creating an external low-impedance short across relay contacts on the power PCB. During thermal measurements, relay contacts are kept shorted as they are not rated for high current.

SSCB Demo performance test

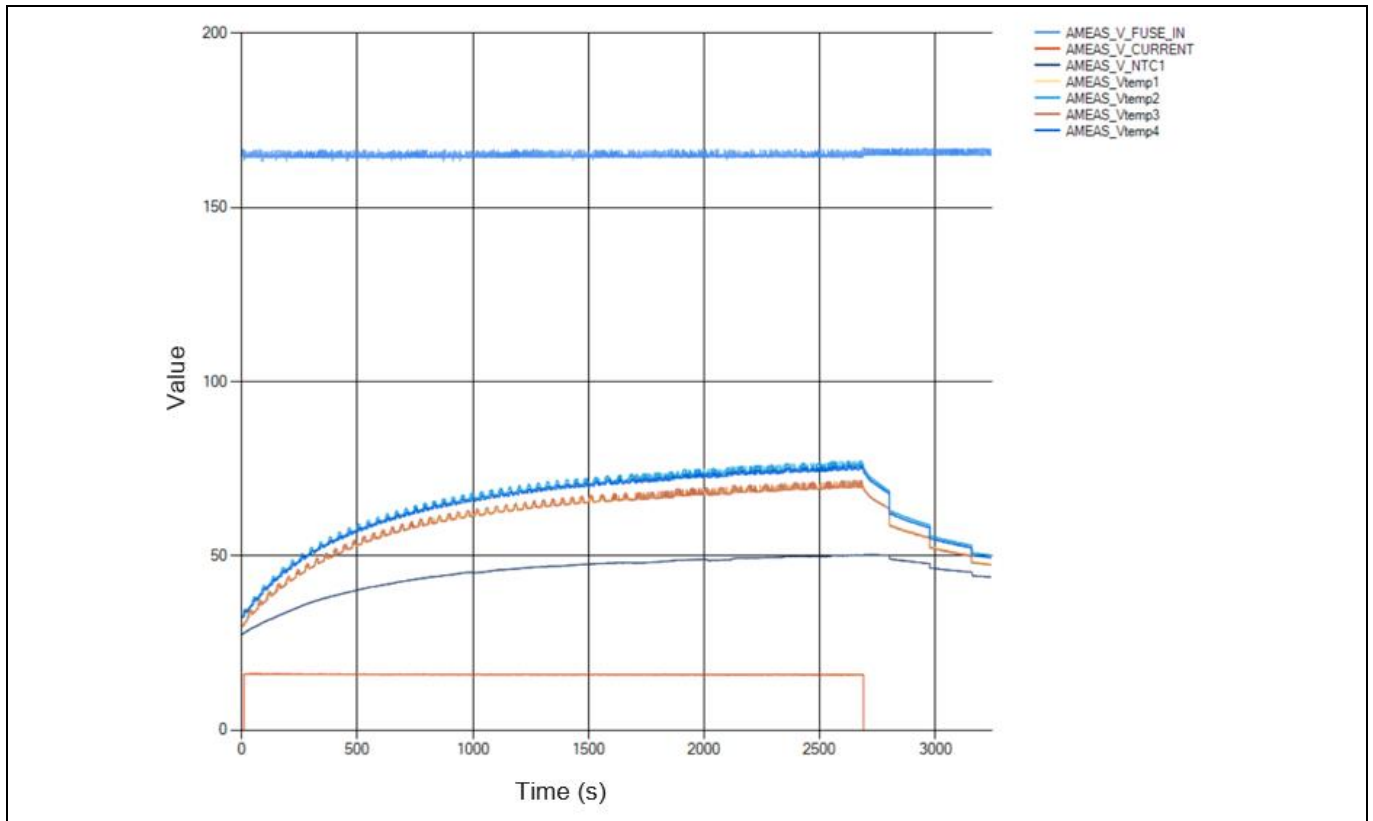

Figure 32 16 A AC continuous current test

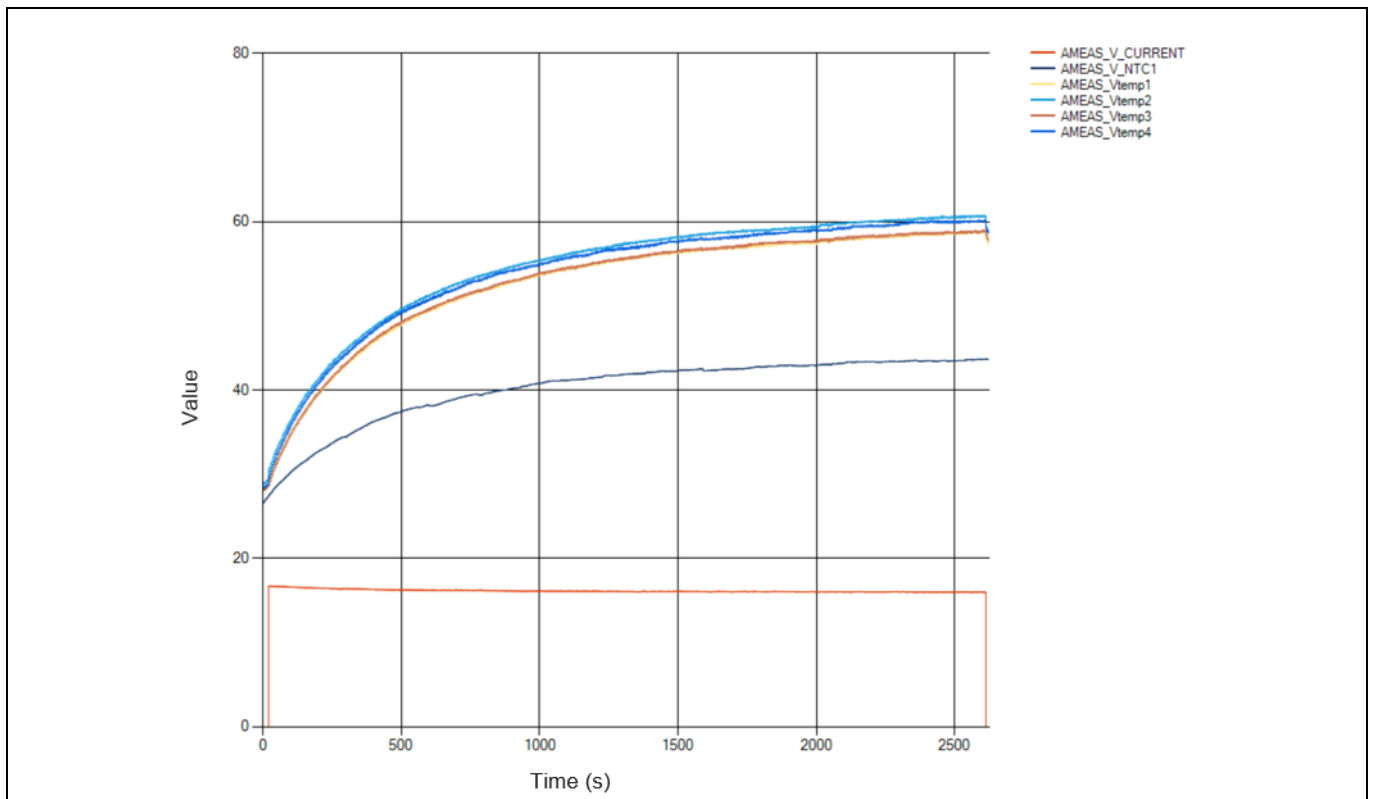

Figure 33 16 A DC continuous current

SSCB Demo performance test

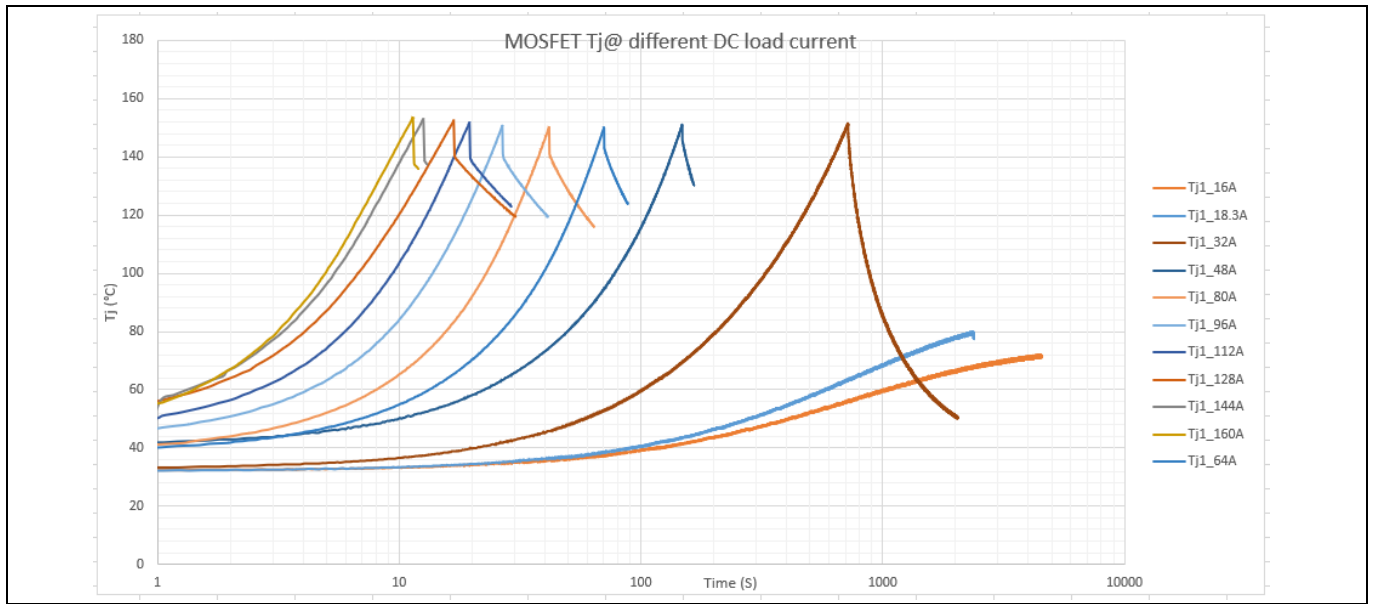

Figure 34 T_j vs. time for different DC load currents

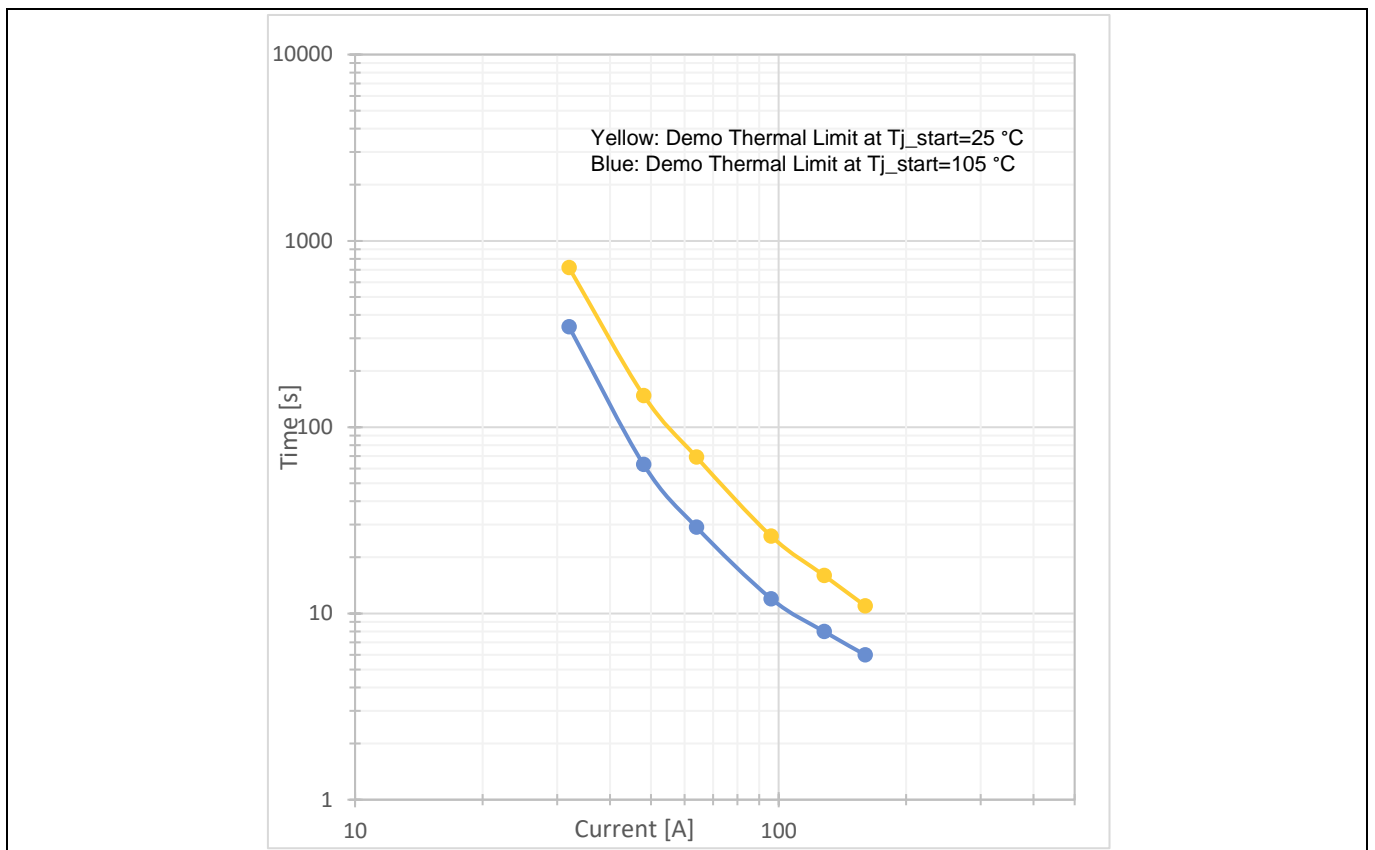

Figure 35 Thermal tripping limit characteristics

SSCB Demo performance test

Glossary

ADC

analog-to-digital converter

MCU

microcontroller

MOSFET

metal oxide semiconductor field-effect transistor

NTC

negative temperature coefficient

OCD

overcurrent detection

OVT

overtemperature warning

PCB

printed circuit board

 $R_{DS(on)}$

MOSFET on resistance at the actual junction temperature

SELV

safety extra low voltage

FELV

functional extra low voltage

SSCB

solid-state circuit breaker

 T_a

ambient temperature

 T_j

junction temperature

TSC

top-side cooling

TVS

transient voltage suppressor

USL

upper specification limit

SSCB Demo performance test

V_{DS}
drain-source voltage

S7T
Infineon CoolMOS™ S7 with embedded temperature sensor

Revision history

Revision history

Document revision	Date	Description of changes
V1.0	2024-01-09	Initial release

Trademarks

All referenced product or service names and trademarks are the property of their respective owners.

Edition 2024-01-09

Published by

Infineon Technologies AG

81726 Munich, Germany

© 2024 Infineon Technologies AG.

All Rights Reserved.

Do you have a question about this document?

Email: erratum@infineon.com

Document reference

UG 2311_PL52_2312_121012

Warnings

Due to technical requirements products may contain dangerous substances. For information on the types in question please contact your nearest Infineon Technologies office.

Except as otherwise explicitly approved by Infineon Technologies in a written document signed by authorized representatives of Infineon Technologies, Infineon Technologies' products may not be used in any applications where a failure of the product or any consequences of the use thereof can reasonably be expected to result in personal injury.

X-ON Electronics

Largest Supplier of Electrical and Electronic Components

Click to view similar products for [Power Management IC Development Tools](#) category:

Click to view products by [Infineon](#) manufacturer:

Other Similar products are found below :

[EVB-EP5348UI](#) [BQ25010EVM](#) [ISL80019AEVAL1Z](#) [ISLUSBI2CKIT1Z](#) [ISL8002AEVAL1Z](#) [ISL91108IIA-EVZ](#) [MAX8556EVKIT](#)
[MAX15005AEVKIT+](#) [ISL28022EVKIT1Z](#) [STEVAL-ISA008V1](#) [DRI0043](#) [KITPF8100FRDMEVM](#) [EVB-EN6337QA](#)
[SAMPLEBOXILD8150TOBO1](#) [MAX18066EVKIT#](#) [AP62300WU-EVM](#) [KITA2GTC387MOTORCTRTOBO1](#) [AEK-MOT-TK200G1](#)
[EVLONE65W](#) [STEVAL-ILH006V1](#) [STEVAL-IPE008V2](#) [STEVAL-IPP001V2](#) [STEVAL-ISA013V1](#) [STEVAL-ISA067V1](#) [STEVAL-](#)
[ISQ002V1](#) [TPS2306EVM-001](#) [TPS2330EVM-185](#) [TPS40001EVM-001](#) [SECO-HVDCDC1362-15W-GEVB](#) [BTS7030-2EPA](#)
[LT8638SJV#WPBF](#) [LTC3308AIV#WTRPBF](#) [TLT807B0EPV](#) [BTS71033-6ESA](#) [EV13N91A](#) [EASYPIC V8 OVER USB-C](#) [EV55W64A](#)
[CLICKER 4 FOR STM32F4](#) [EASYMX PRO V7A FOR STM32](#) [CLICKER 4 FOR PIC18F](#) [Si8285_86v2-KIT](#) [PAC52700EVK1](#) [NCP-](#)
[NCV51752D2PAK3LGEVB](#) [ISL81807EVAL1Z](#) [AP33772S-EVB](#) [EVALM7HVIGBTFCINV4TOBO1](#) [903-0300-000](#) [902-0173-000](#) [903-](#)
[0301-000](#) [ROA1286023/1](#)