

Solid-state-relay reference design user guide

REF_SSR_AC_DC_2A

About this document

Scope and purpose

This user guide describes how to use the solid-state-relay (SSR) reference design board: REF_SSR_AC_DC_2A. It also provides a brief overview of the SSR concept and helpful design tips.

Intended audience

This document is intended for engineers evaluating a possibility to use solid-state relays in combination with Infineon devices.

Reference Board/Kit

Product(s) embedded on a PCB with a focus on specific applications and defined use cases that may include software. PCB and auxiliary circuits are optimized for the requirements of the target application.

Important notice

Important notice

“Evaluation Boards and Reference Boards” shall mean products embedded on a printed circuit board (PCB) for demonstration and/or evaluation purposes, which include, without limitation, demonstration, reference and evaluation boards, kits and design (collectively referred to as “Reference Board”).

Environmental conditions have been considered in the design of the Evaluation Boards and Reference Boards provided by Infineon Technologies. The design of the Evaluation Boards and Reference Boards has been tested by Infineon Technologies only as described in this document. The design is not qualified in terms of safety requirements, manufacturing and operation over the entire operating temperature range or lifetime.

The Evaluation Boards and Reference Boards provided by Infineon Technologies are subject to functional testing only under typical load conditions. Evaluation Boards and Reference Boards are not subject to the same procedures as regular products regarding returned material analysis (RMA), process change notification (PCN) and product discontinuation (PD).

Evaluation Boards and Reference Boards are not commercialized products, and are solely intended for evaluation and testing purposes. In particular, they shall not be used for reliability testing or production. The Evaluation Boards and Reference Boards may therefore not comply with CE or similar standards (including but not limited to the EMC Directive 2004/EC/108 and the EMC Act) and may not fulfill other requirements of the country in which they are operated by the customer. The customer shall ensure that all Evaluation Boards and Reference Boards will be handled in a way which is compliant with the relevant requirements and standards of the country in which they are operated.

The Evaluation Boards and Reference Boards as well as the information provided in this document are addressed only to qualified and skilled technical staff, for laboratory usage, and shall be used and managed according to the terms and conditions set forth in this document and in other related documentation supplied with the respective Evaluation Board or Reference Board.

It is the responsibility of the customer’s technical departments to evaluate the suitability of the Evaluation Boards and Reference Boards for the intended application, and to evaluate the completeness and correctness of the information provided in this document with respect to such application.

The customer is obliged to ensure that the use of the Evaluation Boards and Reference Boards does not cause any harm to persons or third party property.

The Evaluation Boards and Reference Boards and any information in this document is provided "as is" and Infineon Technologies disclaims any warranties, express or implied, including but not limited to warranties of non-infringement of third party rights and implied warranties of fitness for any purpose, or for merchantability.

Infineon Technologies shall not be responsible for any damages resulting from the use of the Evaluation Boards and Reference Boards and/or from any information provided in this document. The customer is obliged to defend, indemnify and hold Infineon Technologies harmless from and against any claims or damages arising out of or resulting from any use thereof.

Infineon Technologies reserves the right to modify this document and/or any information provided herein at any time without further notice.

Safety precautions

Safety precautions

Note: Please note the following warnings regarding the hazards associated with development systems

Table 1 Safety precautions

	<p>Warning: The evaluation or reference board is connected to the grid input during testing. Hence, high-voltage differential probes must be used when measuring voltage waveforms by oscilloscope. Failure to do so may result in personal injury or death. Darkened display LEDs are not an indication that capacitors have discharged to safe voltage levels.</p>
	<p>Warning: Remove or disconnect grid input power from the boards before you disconnect or reconnect wires or perform maintenance work. Failure to do so may result in personal injury or death. GUI or display measurements may not be an indication that supply is at safe voltage levels as communication may get interrupted during testing.</p>
	<p>Caution: The heat sink and device surfaces of the evaluation or reference board may become hot during testing. Hence, necessary precautions are required while handling the board. Failure to comply may cause injury.</p>
	<p>Caution: Only personnel familiar with the drive, power electronics and associated machinery should plan, install, commission and subsequently service the system. Failure to comply may result in personal injury and/or equipment damage.</p>
	<p>Caution: The evaluation or reference board contains parts and assemblies sensitive to electrostatic discharge (ESD). Electrostatic control precautions are required when installing, testing, servicing or repairing the assembly. Component damage may result if ESD control procedures are not followed. If you are not familiar with electrostatic control procedures, refer to the applicable ESD protection handbooks and guidelines.</p>
	<p>Caution: A load and/or boards that are incorrectly applied or installed can lead to component damage or reduction in product lifetime. Wiring or application errors such as undersizing the load or wires, supplying an incorrect or inadequate AC supply, or excessive ambient temperatures may result in system malfunction.</p>
	<p>Caution: The evaluation or reference board is shipped with packing materials that need to be removed prior to installation. Failure to remove all packing materials that are unnecessary for system installation may result in overheating or abnormal operating conditions.</p>

Table of contents

About this document	1
Important notice	2
Safety precautions	3
Table of contents	4
1 Introduction to SSR	5
1.1 Block diagram.....	5
1.2 Key features	6
1.3 Board parameters and technical data.....	7
2 System and functional description	8
2.1 Getting started.....	8
2.2 Operation.....	9
2.3 Overcurrent protection	9
2.4 Overtemperature protection	9
2.5 Overvoltage protection	9
2.5.1 TVS diode dimensioning.....	9
3 System design	11
3.1 Schematics	11
3.2 Layout	12
3.3 Bill of materials.....	12
3.4 Connector details	13
4 System performance	14
4.1 Steady-state behavior	14
4.2 Overcurrent protection	15
4.3 Overtemperature protection	16
References	18
Glossary	19
Revision history	20
Disclaimer	21

1 Introduction to SSR

Solid-state relays are electronic switches capable of turning a circuit on or off using a small control signal, typically a low-voltage DC signal. Traditionally, most relays used on the market today are electromechanical, meaning they consist of mechanical moving parts. Contrary to this, this board has no moving parts and is based on semiconductor technology. This reference board serves as a guide on using and designing such an SSR board.

The SSR reference design (REF_SSR_AC_DC_2A) is suitable for switching up to 2 A nominal current loads in a 250 VAC or 350 VDC grid supply.

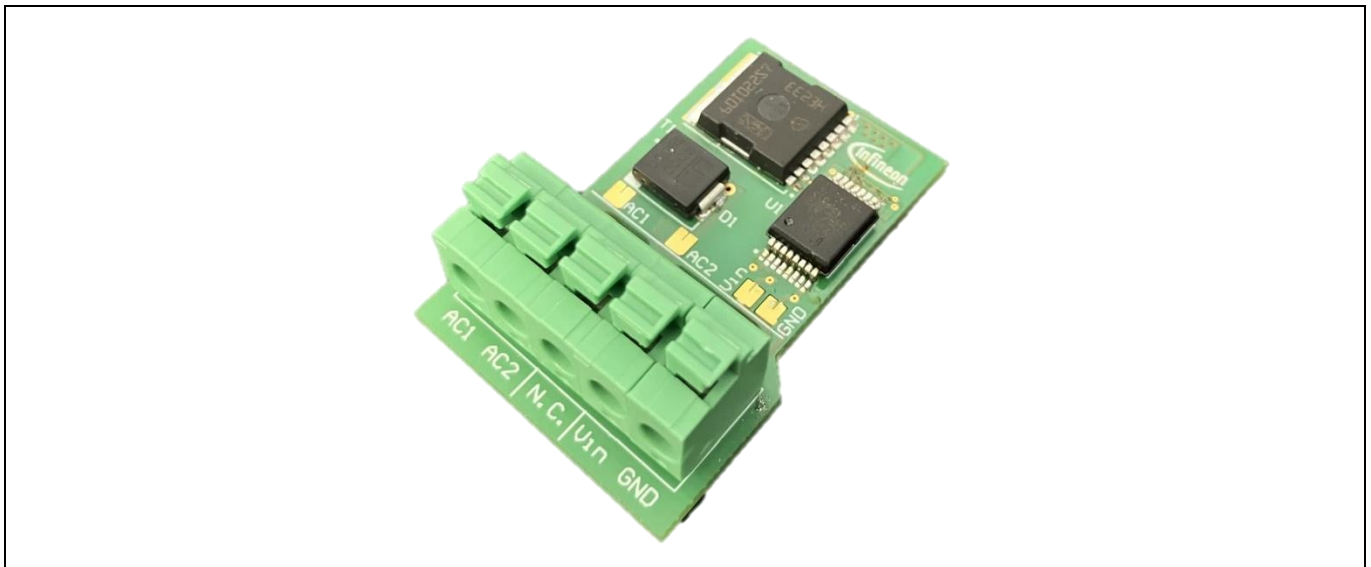

Figure 1 SSR reference board

1.1 Block diagram

As shown in [Figure 2](#), back-to-back MOSFETs are used to support the bidirectional current blocking capability. There are two isolated voltage domains, the input of the gate driver and the grid AC or DC supply. For this version of the board, the logic input is 3.3 V, but it can be changed by adjusting the resistor (see [Table 2](#)). The gate driver has an integrated transformer that provides the gate driving voltage to the MOSFETs. There is a transient-voltage-suppression (TVS) diode across the FETs to clamp the inductive energy at the switch-off. The overtemperature and overcurrent protection are achieved by using the junction temperature measurement and a shunt resistor respectively.

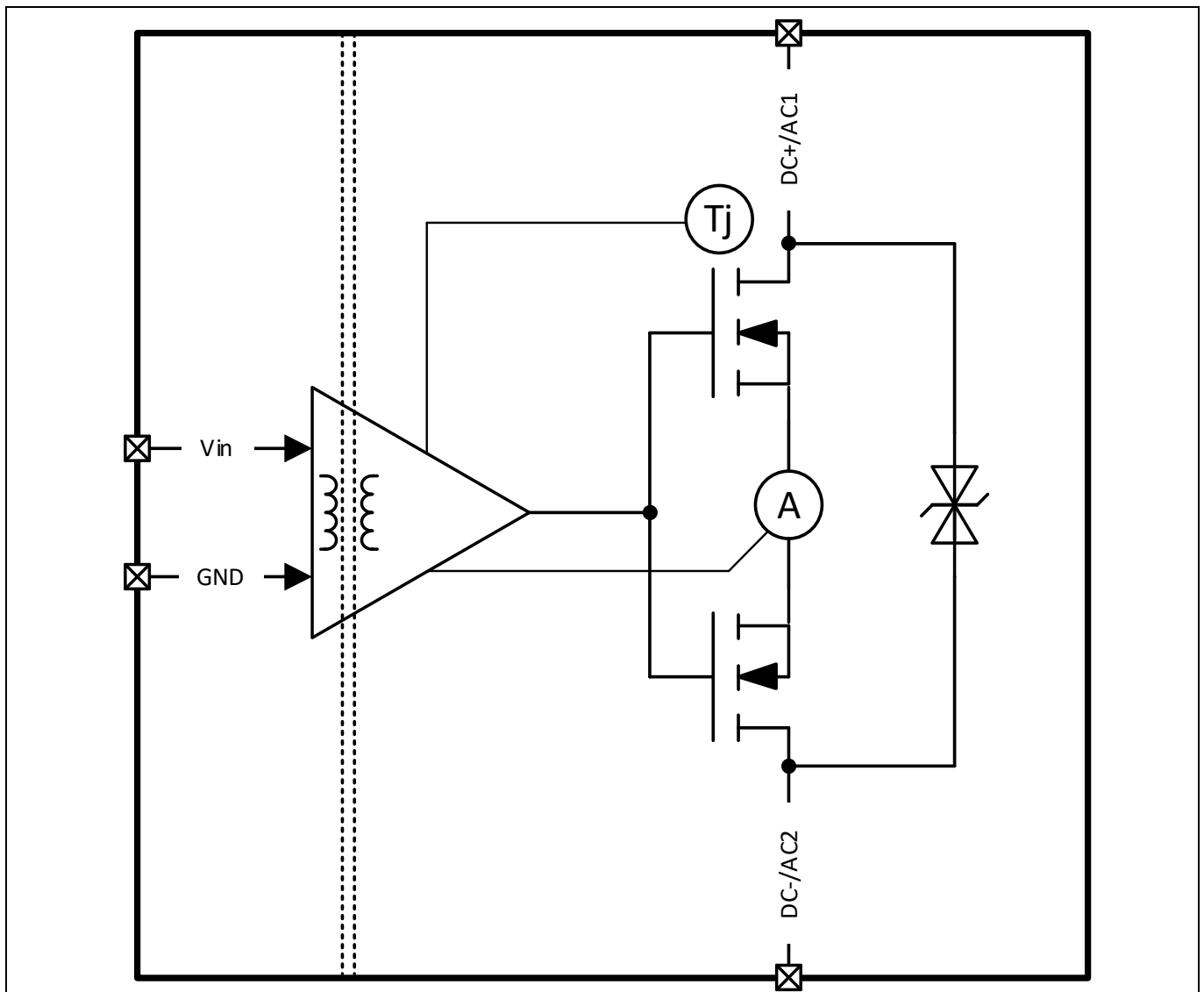

Figure 2 Block diagram of SSR

1.2 Key features

The key electrical features of the SSR reference design are as follows:

- Back-to-back (B2B) CoolMOS™ configuration for bidirectional current blocking capability
- Adjustable input supply voltage
- CoolMOS™ S7T (IPT60T022S7) [1] power FETs with embedded temperature sensor for measuring the junction temperature (T_j) and enabling overtemperature protection
- Shunt resistor-based channel current measurement
- Solid-State Isolator (ISSI30R12H) [2] with integrated provisions for overcurrent (OCD) and overtemperature protection (OVT)
- External clamping elements for overvoltage protection (OVP)

1.3 Board parameters and technical data

Table 2 Operating parameters

Parameter	Min.	Typ.	Max.	Unit
Maximum switching voltage	–	250	–	V AC
	–	350	–	V DC
Nominal switching current	–	2	–	A
Input supply voltage [2]	2.5	3.3	3.5	V DC
Overcurrent limit	27	29	31	A
Overtemperature limit	145	150	155	°C
Ambient operating temperature (Ta)	–	25	40	°C
Pollution degree	II			
Overvoltage category	II			
Maximum altitude	2000 m			

Note: For more information on the input supply voltage, see the [ISSI30R12H datasheet](#) (Chapter 7.1 Adaptation of the supply voltage).

2 System and functional description

2.1 Getting started

To use a relay, a simple connection diagram can be observed (Figure 3).

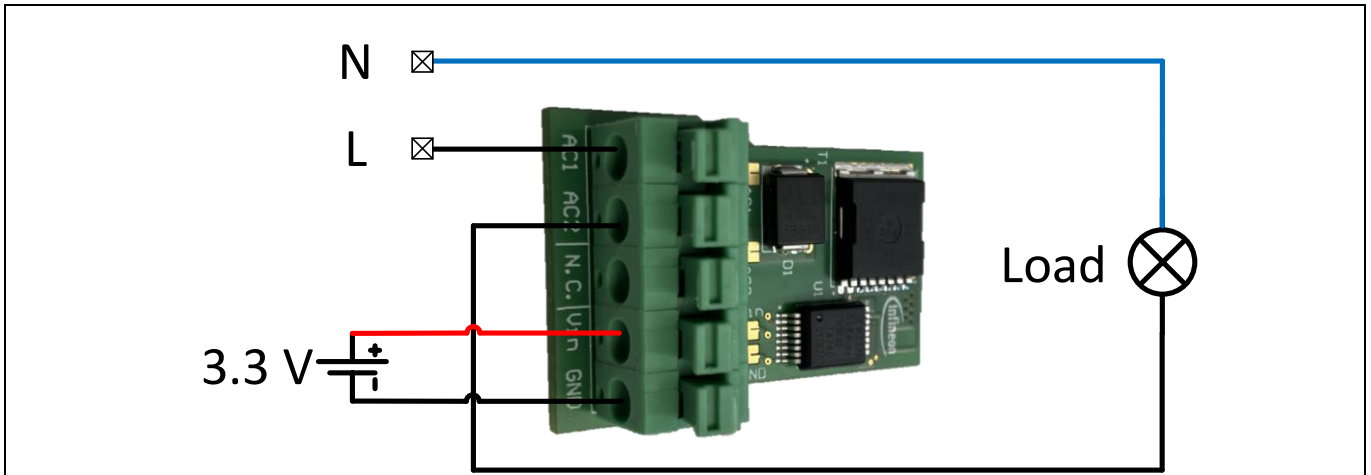

Figure 3 SSR connection diagram

In addition to using a terminal connector block, respective pads on the board can also be used (Figure 4). These can be used by breaking off the connector block and directly soldering the wires or leads to the pads of the device. This way, a reduced footprint of the device can be achieved. However, for evaluation purposes and ease of use, using the connector block is recommended.

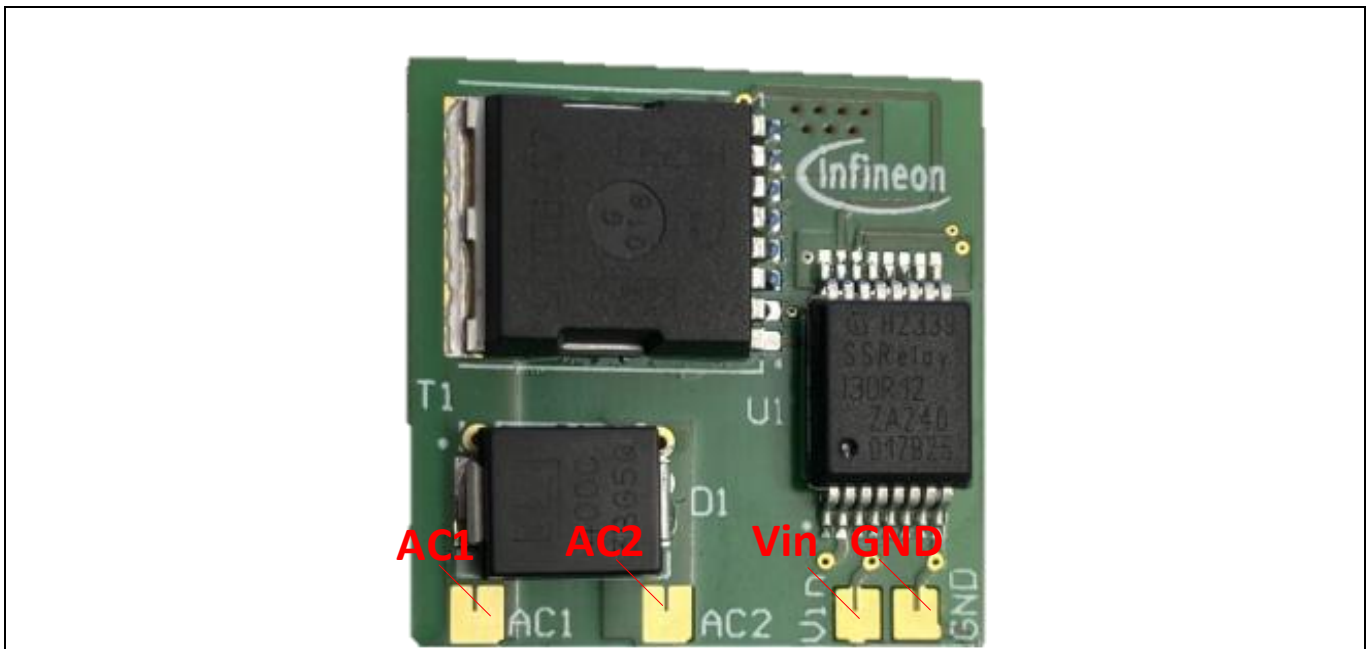

Figure 4 Additional connection pads

2.2 Operation

The device is simple to operate and can be used as any other switch/relay on the market. When the logic supply voltage is present, the SSR is “ON” (conducting). By disabling the logic supply input, the SSR turns “OFF” (not conducting).

Additional features compared to a standard relay are overcurrent, overtemperature, and overvoltage protection.

2.3 Overcurrent protection

The overcurrent protection is achieved with a combination of a shunt resistor used for current measurement and an overcurrent comparator shutdown threshold implemented in the gate driver. The typical comparator shutdown threshold is internally set in the gate driver at a value of 200 mV. By using a 7 mΩ shunt, a typical shutdown current of 29 A can be expected. This overcurrent value is selected to support the AC-15 system tests as per IEC 60947-5-1 guidelines under appropriate operating conditions.

The triggering of the overcurrent protection leads to a latched turn-off of the power switch. To return to normal operation, applying 0 V to the supply input is required.

2.4 Overtemperature protection

The overtemperature is achieved by using the combination of CoolMOS™ S7T and the iSSI30R12H gate driver. The gate driver can source the bias current of 50 μA needed for the readout of the integrated temperature sensor of the S7T MOSFET. At the same time, it detects a typical threshold voltage of 1.095 V, which correlates to a junction temperature of ≈150°C. For more details on how the integrated temperature sensor of the S7T works, see the product application note [4].

Once again, the triggering of the overtemperature protection leads to a latched turn-off of the power switch. To return to normal operation, applying 0 V to the logic supply input is required.

2.5 Overvoltage protection

As an additional protection element, a bidirectional TVS diode is added. In such a compact layout, an additional RC snubber is also needed to prevent the return-on of the device caused by the high-frequency oscillations happening due to TVS diode coupling with the gate output of the driver. For larger boards, placing the TVS further away from the gate driver and MOSFET helps in this perspective by filtering out the high-frequency noise caused by the TVS.

2.5.1 TVS diode dimensioning

The absolute maximum drain-source voltage of the S7T MOSFET is 600 V. The protection elements need to be selected so that the clamping voltage is below this value under all stress patterns. On the other hand, the TVS clamping voltage needs to be above the peak value of the maximum rated supply voltage. The needed clamping range for the TVS diode can be seen in [Figure 5](#). The diode must be selected in a way that the diode breakdown voltage (V_{BR}) is larger than the peak value of the supply voltage ($V_{e(peak)}$). Simultaneously, the maximum clamping voltage (V_C) needs to be lower than the transistor breakdown voltage ($V_{(BR)DSS}$).

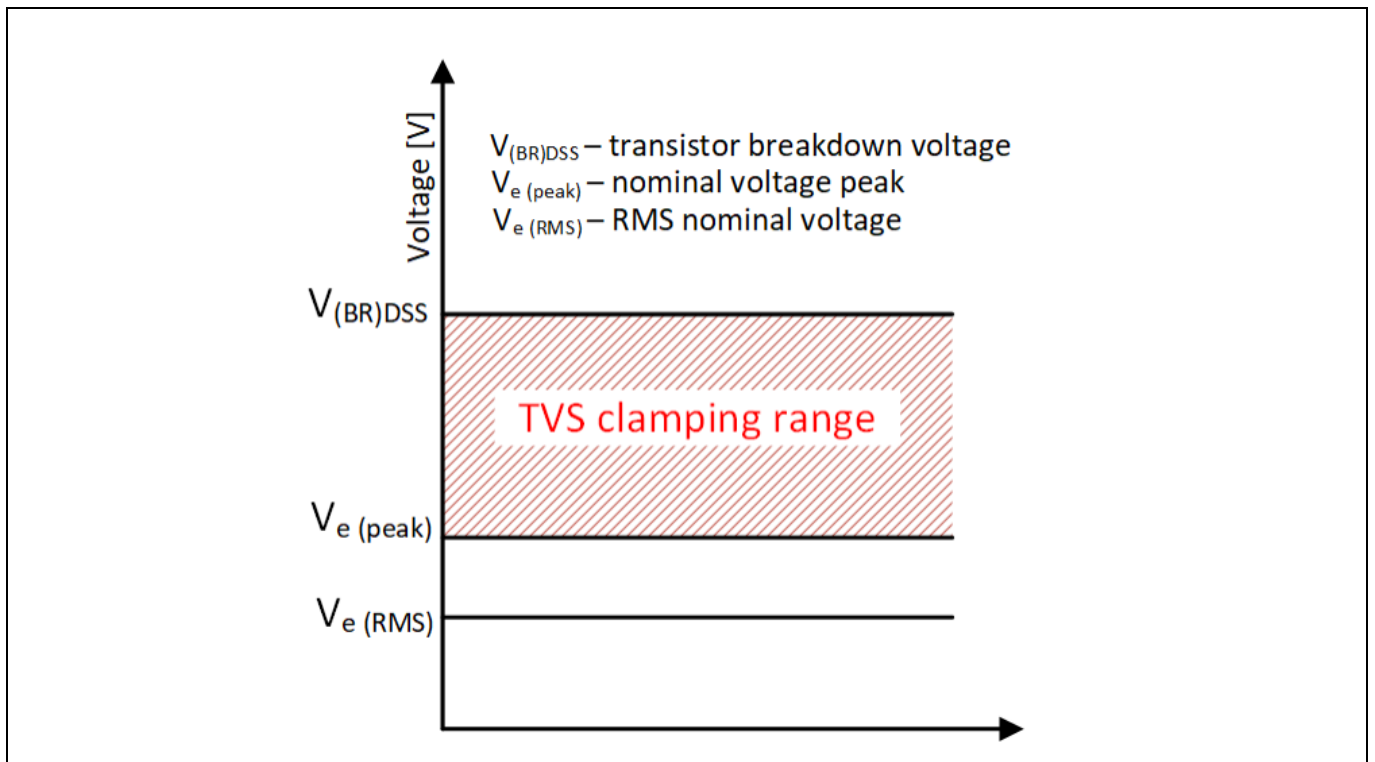

Figure 5 TVS diode clamping range

3 System design

3.1 Schematics

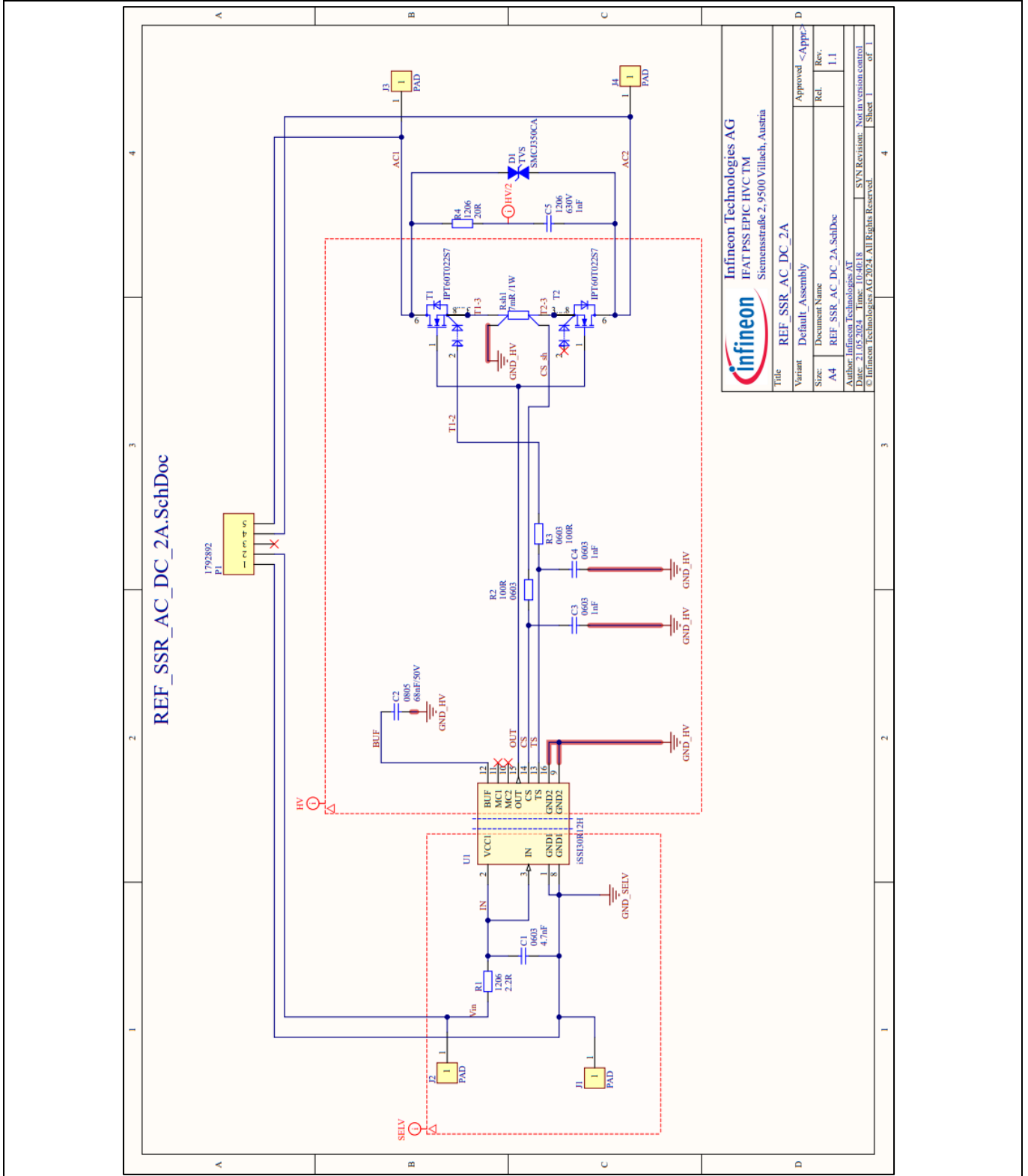

Figure 6 Schematic of REF_SSR_AC_DC_2A

3.2 Layout

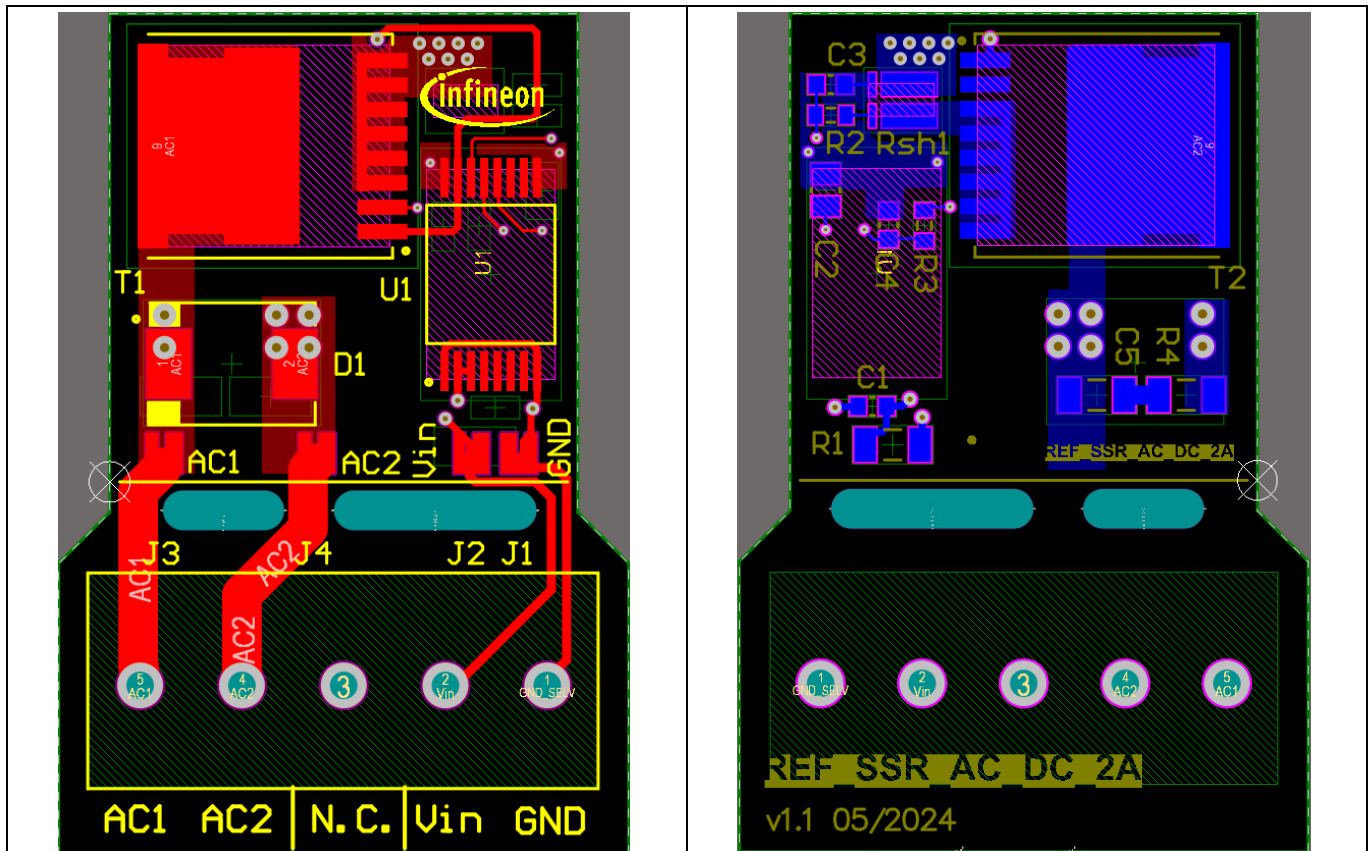

Figure 7 Top (left) and bottom (right) layers of REF_SSR_AC_DC_2A

3.3 Bill of materials

The complete bill of materials is available on the download section of the Infineon website. Log in to download this information.

Table 3 BOM of REF_SSR_AC_DC_2A

Quantity	Ref designator	Description	Manufacturer	Manufacturer P/N	Populated
1	C1	CAP SMD CER 4.7 nF 50V X7R 0603	Multicorp PRO	MCSH18B472K500CT	Yes
1	C2	CAP SMD CER 68 nF 50V X7R 0805	Kemet	C0805C683J5RACTU	Yes
2	C3, C4	CAP SMD CER 1000 pF 50V X7R 0603	Yageo	CC0402KRX7R9BB102	Yes
1	C5	CAP SMD CER 1000 pF, 630 V, 50 V COG, 1206	Murata	GRM31B5C2J102JW01L	Yes
1	D1	TVD DIODE SMC	LittleFuse	SMCJ350CA	Yes
1	P1	Connector block	Phoenix	1792892	Yes
1	R1	RES SMD 2.2 Ω 1206	Vishay	CRCW12062R20FKEA	Yes

System design

Quantity	Ref designator	Description	Manufacturer	Manufacturer P/N	Populated
2	R2, R3	RES SMD 100 Ω 0603	Vishay	CRCW0603100RJNEAIF	Yes
1	R4	RES SMD 20 Ω 1206	Yageo	RC1206JR-0720RL	Yes
1	Rsh1	RES SHUNT 7 m Ω	SUSUMU	KRL3216T4A-M-R007-F-T1	Yes
2	T1, T2	MOSFET N-CH 600 V PG-HSOF-8	Infineon	IPT60T022S7	Yes
1	U1	ISOLATED GATE DRIVER PG-DSO-16- 28	Infineon	ISSI30R12H	Yes

3.4 Connector details

Table 4 Connectors

Pin	Label	Function
1	GND	Logic supply pin reference
2	Vin	Logic supply pin
3	N.C.	Not connect
4	AC2	Power output pin (AC or DC-) ¹
5	AC1	Power input pin (AC or DC+) ¹

¹ Pins AC1 and AC2 interchangeable for AC operation.

4 System performance

In the following sections, certain aspects of the system’s performance are evaluated.

- The steady-state behavior and the I²t curve of the device is shown.
- Some of the cases of overcurrent and overtemperature protection behaviors are shown.

4.1 Steady-state behavior

Although the SSR demo board is shipped with a 22 mΩ CoolMOS™ S7T (IPT60T022S7), certain steady-state evaluations have been performed for a 40 mΩ device (IPT60T040S7) as well. Using an IR camera and the temperature sensor, the package temperature after reaching steady-state conditions at certain loads has been evaluated. The settling time is in the range of 1000 seconds, i.e., 16.7 minutes.

In Figure 8, the settling temperature for an SSR using the 22 mΩ can be observed. A constant current pulse of 5 A is applied. After the specified time, the temperature settled at 111°C. Depending on the allowed device temperature in the application, different nominal currents can be selected.

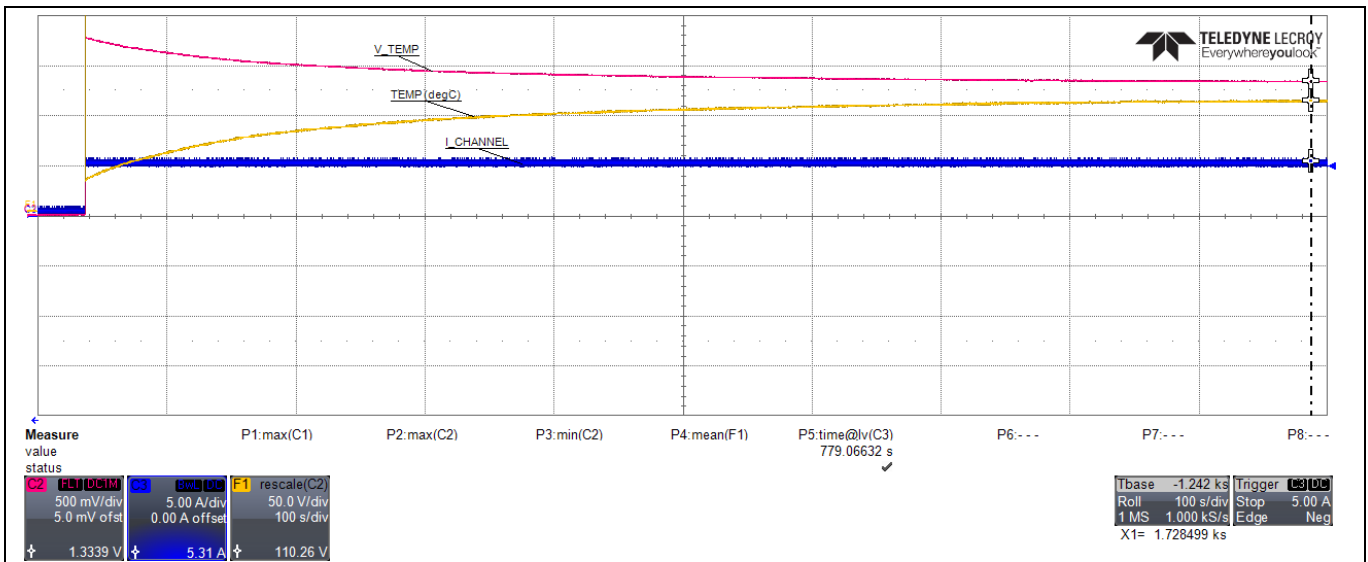

Figure 8 IPT60T022S7 5 A settling temperature

In Table 5, different settling temperatures for different currents can be seen.

Table 5 Settling temperatures at different currents

DC [A]	SSR with 2xIPT60T022S7 settling temp [°C]	SSR with 2xIPT60T040S7 settling temp [°C]
2	41	51
3	53	79
5	111	shutdown after 159 s (OVT)

Apart from the steady-state behavior, transient shutdown behavior can be observed. Considering the SSR consists of two major protection mechanisms, overcurrent and overtemperature shutdown, an I²t tripping curve can be extracted. This curve can be seen in Figure 9 for both the 22 mΩ and 40 mΩ SSRs. The yellow hard limit is the overcurrent shutdown that is based on the shunt, while the red and blue curves are the respective overtemperature shutdown limits. These of course depend on the ambient temperature of the device, which is in this case 25°C. These curves serve as orientation references, being influenced by various design and

System performance

manufacturing factors such as soldering joints and cooling areas. It is important to note that they may not be identical for every device.

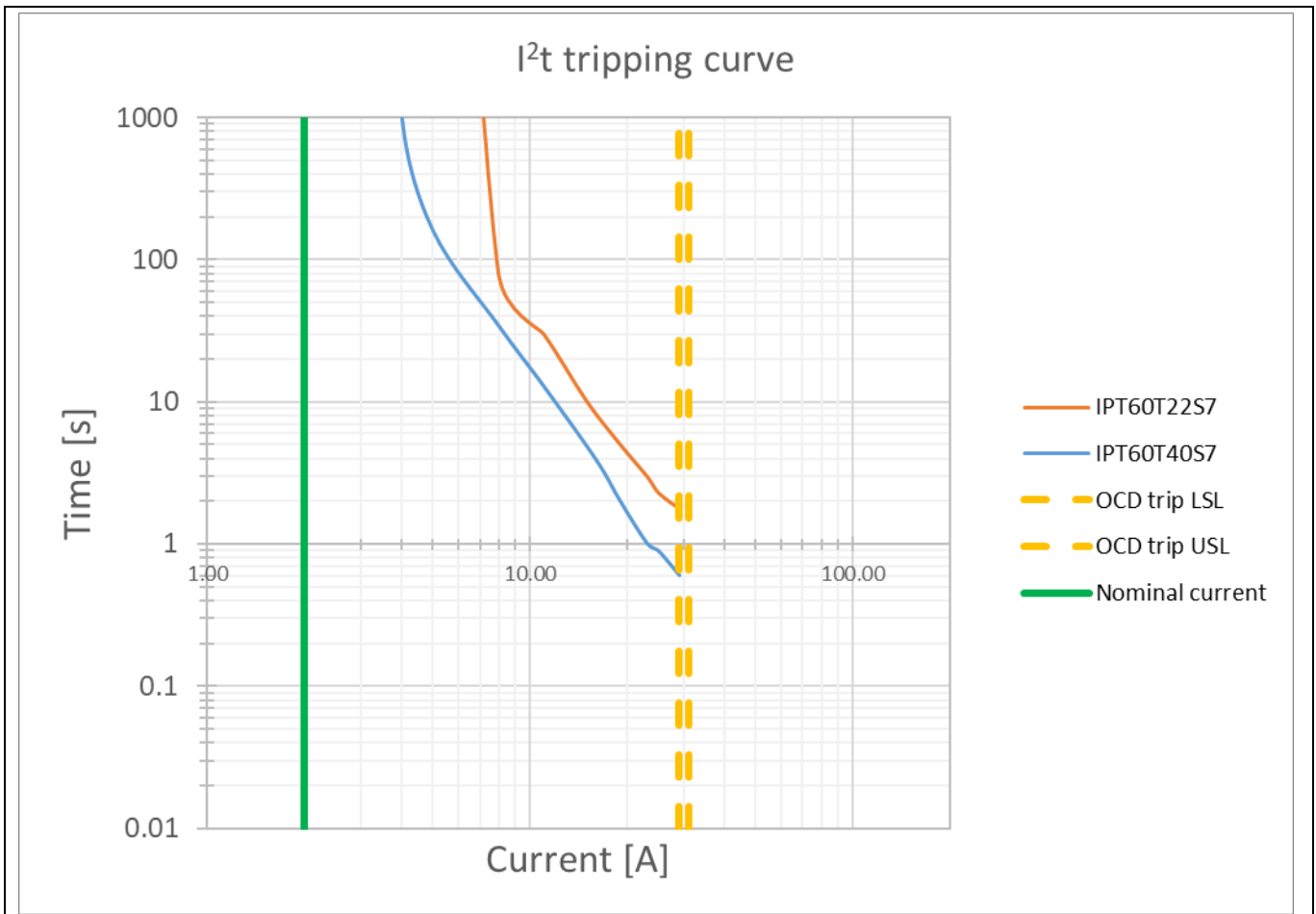

Figure 9 SSR I²t tripping curve

4.2 Overcurrent protection

The implementation of the overcurrent protection was discussed in Section 2.3. In this chapter, the performance of the protection is evaluated. The worst-case condition for an overcurrent protection would be a short-circuit event. Depending on the type of short-circuit event, different current slopes (di/dt) can be expected. To test this, a capacitive load of a high-voltage DC power supply is used. By increasing the voltage level, the short-circuit current slope is higher.

One of these examples can be seen in Figure 10. This is an overcurrent protection scenario with a short-circuit current slope of 41 A/μs. The respective signals are marked on the oscilloscope screenshot. Even with such a steep current slope, the SSR is quick to respond. This can be observed in the gate signal. Counting from the moment of detecting a fault (gate signal falling edge), until the current starts dropping, takes only 140 ns. The device was tested up to 60 A/μs slew rate with a DC voltage of 350 V.

System performance

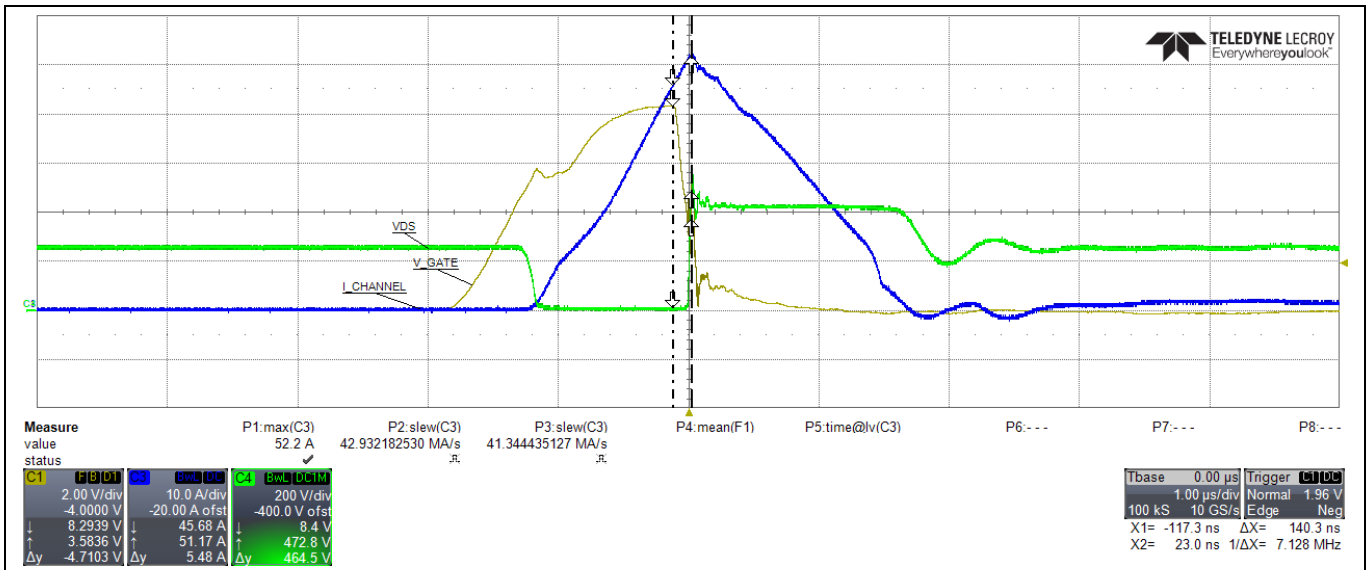

Figure 10 Short-circuit event

With varying slew rates, the maximum trip current varies. As mentioned in the operating conditions, the threshold switch-off current is ≈ 30 A. In Figure 11, a relationship between the current slew rate (di/dt) in an overcurrent event and the maximum tripping current can be seen.

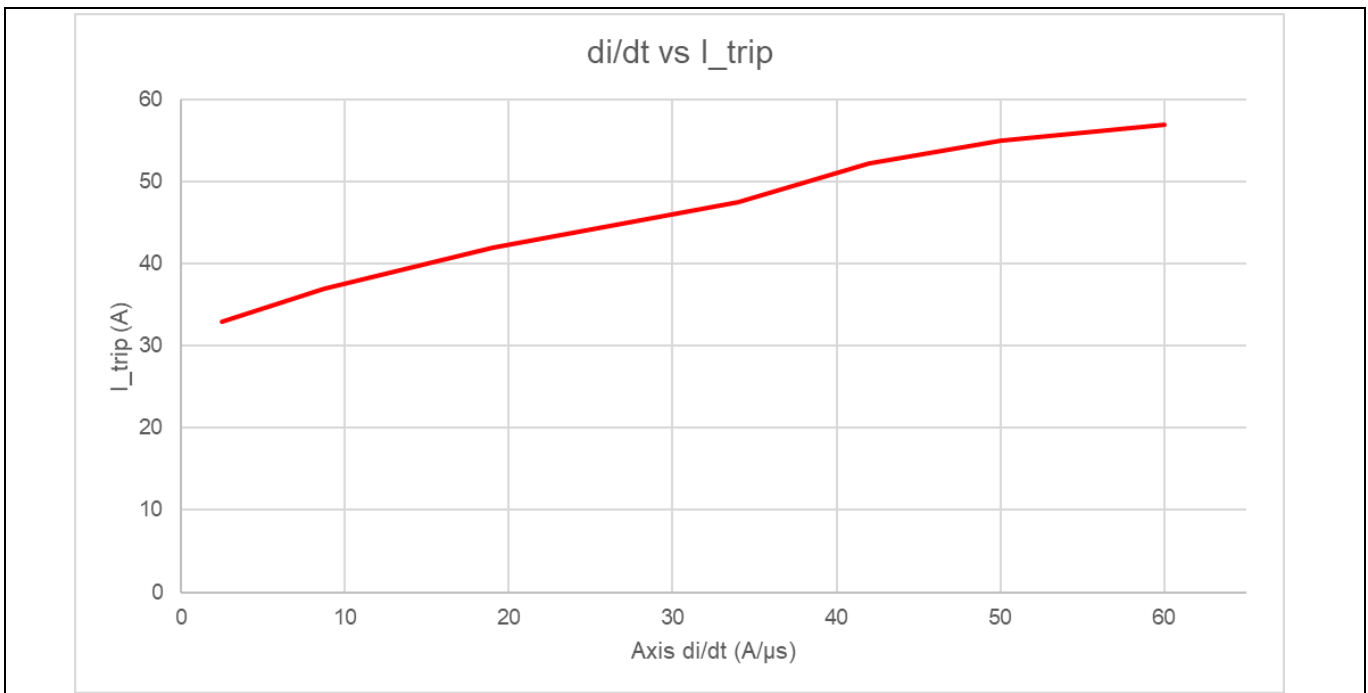

Figure 11 OCD di/dt vs tripping current

4.3 Overtemperature protection

Similarly to the overcurrent protection, overtemperature protection was verified using constant DC current. In Figure 12, an overtemperature shutdown event is observed. The temperature diode voltage (V_TEMP) is dropping (the diode has a negative temperature coefficient) until the set shutdown level. After this, the SSR shuts-off.

Solid-state-relay reference design user guide

REF_SSR_AC_DC_2A

System performance

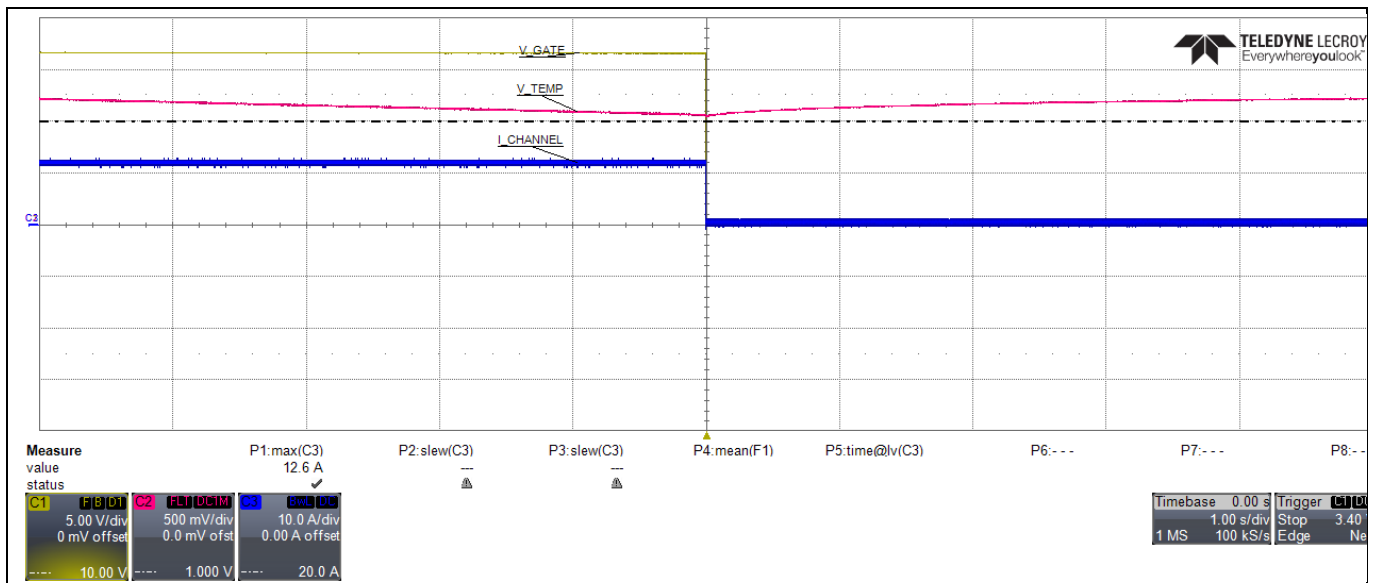

Figure 12 Overtemperature protection event

The same event but zoomed-in can be seen in [Figure 13](#). The device stays latched off until a restart happens by applying 0 V at the input.

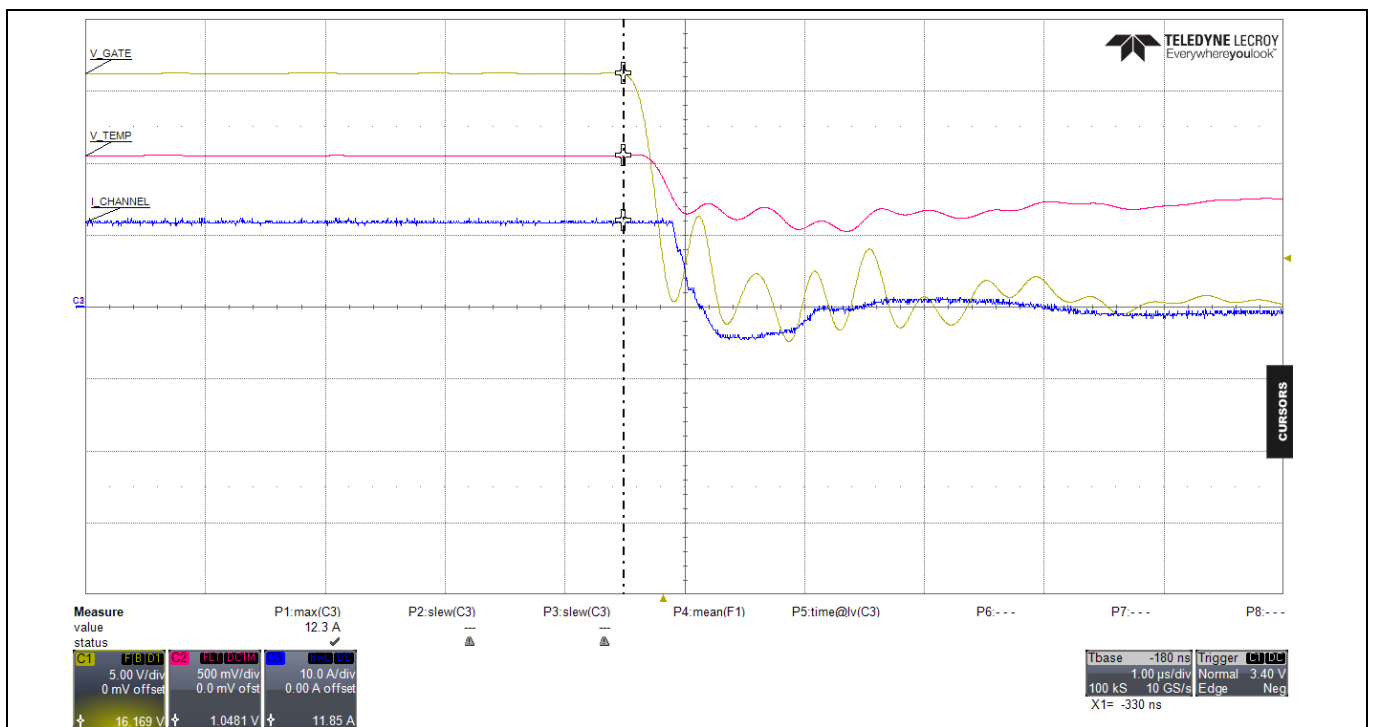

Figure 13 Overtemperature protection event – zoomed in

References

- [1] Infineon Technologies AG.: *IPT60T022S7 datasheet* [Available online](#)
- [2] Infineon Technologies AG.: *iSSI20R0xH, iSSI20R11H, and iSSI30R1xH datasheet* [Available online](#)
- [3] Infineon Technologies AG.: *UG-2023-17, Eval-iSSI30R12H user guide*. [Available online](#)
- [4] Infineon Technologies AG.: *AN_2308_PL52_2310_112138 600 V CoolMOS™ S7 with temperature sense. application note* [Available online](#)

Glossary

Glossary

SSR

solid-state-relay

MOSFET

metal oxide semiconductor field-effect transistor

S7T

Infineon CoolMOS™ S7 with embedded temperature sensor

AC

alternating current

DC

direct current

OCD

overcurrent detection

OVT

overtemperature

OVP

overvoltage protection

TVS

transient-voltage-suppression

LSL

Lower specification limit

USL

Upper specification limit

Revision history

Revision history

Document revision	Date	Description of changes
V 1.0	2024-06-12	Initial revision

Trademarks

All referenced product or service names and trademarks are the property of their respective owners.

Edition 2024-06-12

Published by

Infineon Technologies AG

81726 Munich, Germany

© 2024 Infineon Technologies AG.

All Rights Reserved.

Do you have a question about this document?

Email: erratum@infineon.com

Document reference

UG084603

Warnings

Due to technical requirements products may contain dangerous substances. For information on the types in question please contact your nearest Infineon Technologies office.

Except as otherwise explicitly approved by Infineon Technologies in a written document signed by authorized representatives of Infineon Technologies, Infineon Technologies' products may not be used in any applications where a failure of the product or any consequences of the use thereof can reasonably be expected to result in personal injury.

X-ON Electronics

Largest Supplier of Electrical and Electronic Components

Click to view similar products for [Power Management IC Development Tools](#) category:

Click to view products by [Infineon](#) manufacturer:

Other Similar products are found below :

[EVB-EP5348UI](#) [BQ25010EVM](#) [ISL80019AEVAL1Z](#) [ISLUSBI2CKIT1Z](#) [ISL8002AEVAL1Z](#) [ISL91108IIA-EVZ](#) [ISL28022EVKIT1Z](#)
[STEVAL-ISA008V1](#) [DRI0043](#) [KITPF8100FRDMEVM](#) [NCP10671B05GEVB](#) [EVB-EN6337QA](#) [SAMPLEBOXILD8150TOBO1](#)
[AP62300WU-EVM](#) [KITA2GTC387MOTORCTRTOBO1](#) [AEK-MOT-TK200G1](#) [EVLONE65W](#) [STEVAL-ILH006V1](#) [STEVAL-IPE008V2](#)
[STEVAL-IPP001V2](#) [STEVAL-ISA013V1](#) [STEVAL-ISA067V1](#) [STEVAL-ISQ002V1](#) [TPS2306EVM-001](#) [TPS2330EVM-185](#)
[TPS40001EVM-001](#) [SECO-HVDCDC1362-15W-GEVB](#) [BTS7030-2EPA](#) [LT8638SJV#WPBF](#) [LTC3308AIV#WTRPBF](#) [TLT807B0EPV](#)
[BTS71033-6ESA](#) [EV13N91A](#) [EASYPIC V8 OVER USB-C](#) [EV55W64A](#) [CLICKER 4 FOR STM32F4](#) [EASYMX PRO V7A FOR STM32](#)
[CLICKER 4 FOR PIC18F](#) [Si8285_86v2-KIT](#) [NCP-NCV51752D2PAK3LGEVB](#) [ISL81807EVAL1Z](#) [EVALM7HVIGBTTPFCINV4TOBO1](#)
[903-0300-000](#) [902-0173-000](#) [903-0301-000](#) [ROA1286023/1](#) [REFSHA35IMD111TSYSTOBO1](#) [150037482](#) [SABMB629](#) [TDINV3000W50B-](#)
[KIT](#)