

High-Performance DrBLADE

6.6 mm x 4.5 mm x 0.6 mm

TDA21320

Data Sheet

Revision 2.4, 2015-07-16

Power Management and Multi Market

Edition 2015-07-1626

**Published by
Infineon Technologies AG
81726 Munich, Germany**

**© 2015 Infineon Technologies AG
All Rights Reserved.**

Legal Disclaimer

The information given in this document shall in no event be regarded as a guarantee of conditions or characteristics. With respect to any examples or hints given herein, any typical values stated herein and/or any information regarding the application of the device, Infineon Technologies hereby disclaims any and all warranties and liabilities of any kind, including without limitation, warranties of non-infringement of intellectual property rights of any third party.

Information

For further information on technology, delivery terms and conditions and prices, please contact the nearest Infineon Technologies Office (www.infineon.com).

Warnings

Due to technical requirements, components may contain dangerous substances. For information on the types in question, please contact the nearest Infineon Technologies Office.

Infineon Technologies components may be used in life-support devices or systems only with the express written approval of Infineon Technologies, if a failure of such components can reasonably be expected to cause the failure of that life-support device or system or to affect the safety or effectiveness of that device or system. Life support devices or systems are intended to be implanted in the human body or to support and/or maintain and sustain and/or protect human life. If they fail, it is reasonable to assume that the health of the user or other persons may be endangered.

Revision History

Page or Item	Subjects (major changes since previous revision)
Revision 2.4, 2015-07-16	
	Package drawings figures 18 – 20 updated
	Inserted chapter 10 (packaging information)

Trademarks of Infineon Technologies AG

AURIX™, BlueMoon™, C166™, CanPAK™, CIPOS™, CIPURSE™, COMNEON™, EconoPACK™, CoolMOS™, CoolSET™, CORECONTROL™, CROSSAVE™, DAVE™, EasyPIM™, EconoBRIDGE™, EconoDUAL™, EconoPIM™, EiceDRIVER™, eupec™, FCOS™, HITFET™, HybridPACK™, I²RF™, ISOFACE™, IsoPACK™, MIPAQ™, ModSTACK™, my-d™, NovalithIC™, OmniTune™, OptiMOS™, ORIGA™, PRIMARION™, PrimePACK™, PrimeSTACK™, PRO-SIL™, PROFET™, RASIC™, ReverSave™, SatRIC™, SIEGET™, SINDRION™, SIPMOS™, SMARTi™, SmartLEWIS™, SOLID FLASH™, TEMPFET™, thinQ!™, TRENCHSTOP™, TriCore™, X-GOLD™, X-PMU™, XMM™, XPOSYS™.

Other Trademarks

Advance Design System™ (ADS) of Agilent Technologies, AMBA™, ARM™, MULTI-ICE™, KEIL™, PRIMECELL™, REALVIEW™, THUMB™, μVision™ of ARM Limited, UK. AUTOSAR™ is licensed by AUTOSAR development partnership. Bluetooth™ of Bluetooth SIG Inc. CAT-iq™ of DECT Forum. COLOSSUS™, FirstGPS™ of Trimble Navigation Ltd. EMV™ of EMVCo, LLC (Visa Holdings Inc.). EPCOS™ of Epcos AG. FLEXGO™ of Microsoft Corporation. FlexRay™ is licensed by FlexRay Consortium. HYPERTERMINAL™ of Hilgraeve Incorporated. IEC™ of Commission Electrotechnique Internationale. IrDA™ of Infrared Data Association Corporation. ISO™ of INTERNATIONAL ORGANIZATION FOR STANDARDIZATION. MATLAB™ of MathWorks, Inc. MAXIM™ of Maxim Integrated Products, Inc. MICROTEC™, NUCLEUS™ of Mentor Graphics Corporation. Mifare™ of NXP. MIPI™ of MIPI Alliance, Inc. MIPS™ of MIPS Technologies, Inc., USA. muRata™ of MURATA MANUFACTURING CO., MICROWAVE OFFICE™ (MWO) of Applied Wave Research Inc., OmniVision™ of OmniVision Technologies, Inc. Openwave™ Openwave Systems Inc. RED HAT™ Red Hat, Inc. RFMD™ RF Micro Devices, Inc. SIRIUS™ of Sirius Satellite Radio Inc. SOLARIS™ of Sun Microsystems, Inc. SPANSION™ of Spansion LLC Ltd. Symbian™ of Symbian Software Limited. TAIYO YUDEN™ of Taiyo Yuden Co. TEAKLITE™ of CEVA, Inc. TEKTRONIX™ of Tektronix Inc. TOKO™ of TOKO KABUSHIKI KAISHA TA. UNIX™ of X/Open Company Limited. VERILOG™, PALLADIUM™ of Cadence Design Systems, Inc. VLYNQ™ of Texas Instruments Incorporated. VXWORKS™, WIND RIVER™ of WIND RIVER SYSTEMS, INC. ZETEX™ of Diodes Zetex Limited.

Last Trademarks Update 2010-10-26

1 Applications

- Desktop and Server Vcore and non-Vcore buck-converter
- Single Phase and Multiphase POL
- CPU/GPU Regulation in Notebook, Desktop Graphics Cards, DDR Memory, Graphic Memory
- High Power Density Voltage Regulator Modules (VRM).

2 Features

- **Input voltage range +4.5 V to +16 V**
- Maximum average current up to 60 A
- For synchronous Buck step down voltage applications
- Power MOSFETs rated 25 V for safe operation under all conditions
- Fast switching technology for improved performance at high switching frequencies (> 750 kHz)
- Up to 95.5% peak efficiency¹
- Includes bootstrap diode
- Shoot through protection
- Max +8 V V_{GS} , high-side and low-side MOSFET gate driving voltage
- Compatible to standard +3.3 V PWM controller integrated circuits
- Tri-state PWM input functionality
- Small package: LG-WIQFN-38-1 (6.6x4.5x0.6 mm³)
- RoHS compliant
- Integrated temperature sense
- Integrated current sense

Table 1 Product Identification

Part Number	Temp Range	Package	Marking
TDA21320	-25°C to 125°C	LG-WIQFN-38-1 (6.6x4.5x0.6 mm ³)	TDA21320

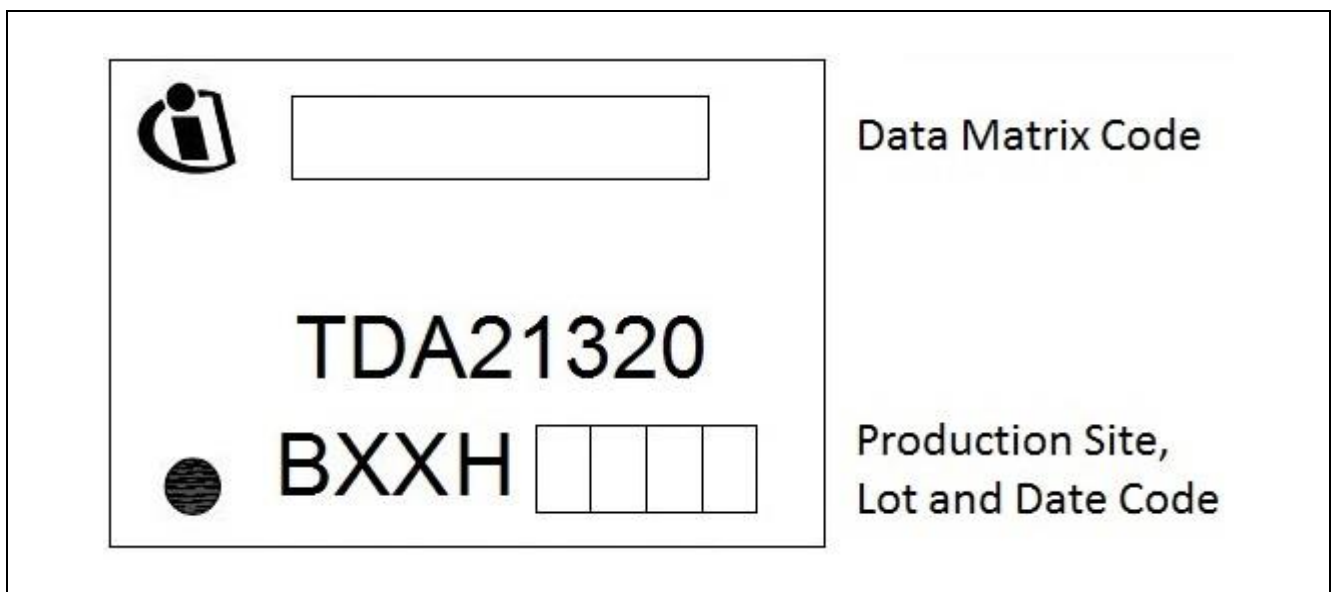

Figure 1 Picture of the Product

¹ $f_{sw} = 429 \text{ kHz}$, $V_{DRV} = 5V$, $V_{in} = 12V$, $V_{out} = 1.8V$, 5 phases, no heatsink, no airflow

3 Description

3.1 Pinout

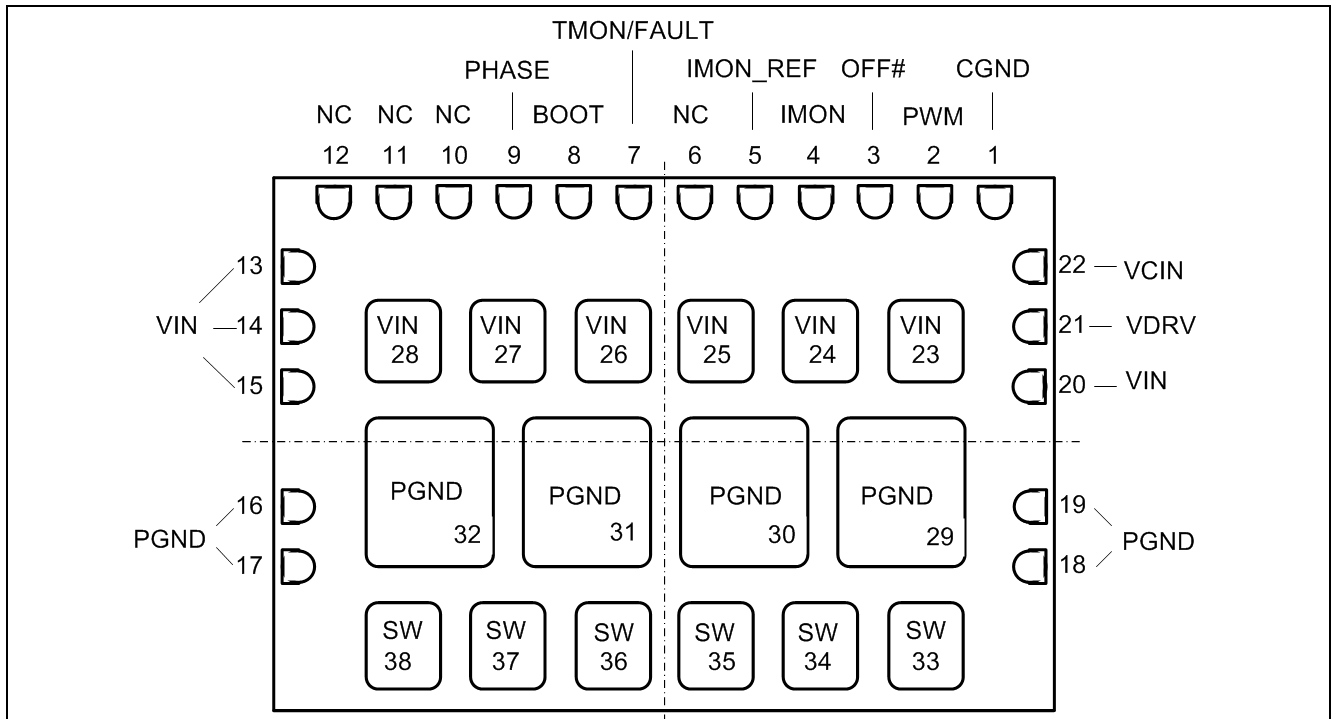

Figure 2 Pinout, Numbering and Name of Pins (transparent top view)

Table 2 I/O Signals

Pin No.	Name	Pin Type	Buffer Type	Function
2	PWM	I/O	+3.3 V logic	PWM drive logic input, Status output for VCIN The tri-state PWM input is compatible with 3.3 V.
3	OFF#	I	+3.3 V logic	Deactivates LS-MOSFET Pull low to prevent LS-FET turn-on. Leave open if not used. (If traced out in noisy layout it may require external pull up.)
4	IMON	O	Analog	Load current Sensing Provides a voltage proportional to the high/low-side MOSFET currents; Leave open if not used.
5	IMONREF	O	Analog	Load current Sensing Reference to pin 4; Leave open if not used.
7	TMON/FAULT	O	Analog/ Digital	Thermal Sensing / Fault Pin Temperature reporting, fault signaling by logic "H"; Status output of VDRV, Leave open if not used.
8	BOOT	I	Analog	Bootstrap voltage pin Connect to BOOT capacitor
9	PHASE	I	Analog	Switch node input Internally connected to SW pins, Connect to BOOT capacitor as reference pin for boot voltage
33-38 (pads)	SW	O	Analog	Switch node output High current output switching node

Table 3 Power Supply

Pin No.	Name	Pin Type	Function
13 – 15, 20, 23-28 (pads)	VIN	POWER	Input voltage Converter input voltage (connected to drain of the high-side MOSFET and driver)
21	VDRV	POWER	MOSFET gate drive supply voltage High and low-side gate drive
22	VCIN	POWER	Driver logic supply voltage bias voltage for the internal logic

Table 4 Ground Pins

Pin No.	Name	Pin Type	Function
1	CGND	GND	Control signal ground Should be connected to local PGND externally, preferably by vias to GND plane
16 – 19, 29-32 (pads)	PGND	GND	Power ground All these pins must be connected to the power GND plane through multiple low inductance vias.

Table 5 Not Connected

Pin No.	Name	Pin Type	Function
6, 10, 11, 12	NC	–	No internal connection Leave pin floating, tie to VIN or GND.

3.2 General Description

The Infineon TDA21320 is a multichip module that incorporates Infineon’s premier MOSFET technology into a single high-side and a single low-side MOSFET. This is coupled with a robust, high performance, high switching frequency gate driver on a single 38 pin LG-WIQFN-38-1 (6.6x4.5x0.6 mm³) package. The optimized gate timing enables significant light load efficiency improvements over discrete solutions. State of the art MOSFET technology provides exceptional performance at full and light load.

When combined with Infineon’s Primarion™ Controller Family of Digital Multi-phase Controllers, the TDA21320 forms a complete core-voltage regulator solution for advanced micro and graphics processors as well as point-of-load applications. The device package height is 0.6 mm. It is an excellent choice for applications with critical height limitations and has reduced thermal impedance from junction to top case compared to DrMOS, allowing for top side cooling.

The power density for transmitted power of this approach is approximately 50 W within a 28 mm² area.

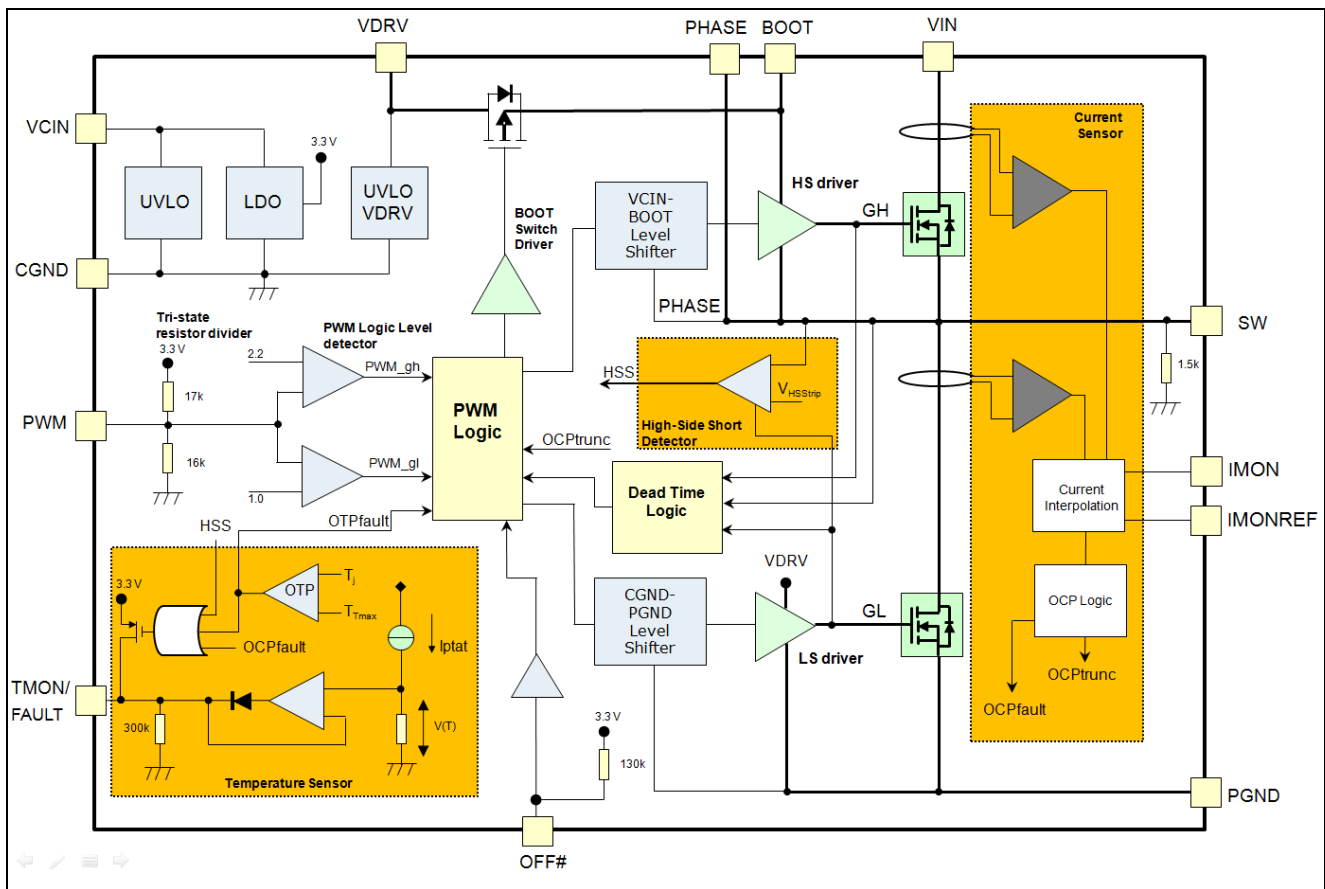

Figure 3 Simplified Block Diagram

Attention: GH and GL are not accessible on this package, but are mentioned for clarity in this block diagram.

4 Electrical Specification

4.1 Absolute Maximum Ratings

Note: $T_A = 25^\circ\text{C}$

Stresses above those listed in Table 6 “Absolute Maximum Ratings” and Figure 4 “Repetitive Voltage Stress at Phase Node - Safe Operating Area” may cause permanent damage to the device. These are absolute stress ratings only and operation of the device is not implied or recommended at these or any other conditions in excess of those given in the operational sections of this specification. Exposure over values of the recommended ratings (Table 8) for extended periods may adversely affect the operation and reliability of the device.

Table 6 Absolute Maximum Ratings

Parameter	Symbol	Values			Unit	Note / Test Condition
		Min.	Typ.	Max.		
Frequency of the PWM input	f_{SW}	0.01 (in CCM)	–	1.2	MHz	rated current sense accuracy between 100 kHz and 800 kHz
Maximum average load current	I_{OUT}	–	–	60	A	–
Input Voltage	V_{IN} (DC)	-0.30	–	18	V	–
Logic supply voltage	V_{CIN} (DC)	-0.30	–	9	V	–
High and low-side driver voltage	V_{DRV} (DC)	-0.30	–	9	V	–
Switch node voltage	V_{SW} (DC)	-1	–	18	V	–
	V_{SW} (AC)	-10^2	–	25^2	V	–
PHASE voltage pin (9)	V_{PHASE} (DC)	-1	–	18	V	–
	V_{PHASE} (AC)	-10^2	–	25^2	V	–
BOOT voltage	V_{BOOT} (DC)	-0.3	–	25	V	–
	V_{BOOT} (AC)	–	–	30^2	V	–
	$V_{\text{BOOT-PHASE}}$ (DC)	-0.3	–	9	V	–
OFF# voltage	$V_{\text{OFF\#}}$	-0.3	–	4	V	Maximum value valid for operation up to 24h accumulated over lifetime in temperature range of $-25^\circ\text{C} \leq T_j \leq 125^\circ\text{C}$. Else the maximum value is 3.6V.
PWM voltage	V_{PWM}	-0.3	–	4	V	
TMON/FAULT	$V_{\text{TMON/FAULT}}$	-0.3	–	3.6	V	–
IMON	V_{IMON}	-0.3	–	3.6	V	–
IMONREF	V_{IMONREF}	-0.3	–	3.6	V	–
Junction temperature	T_{Jmax}	-40	–	150	$^\circ\text{C}$	–
Storage temperature	T_{STG}	-55	–	150	$^\circ\text{C}$	–

Note: All rated voltages are relative to voltages on the CGND and PGND pins unless otherwise specified.

² AC is limited to 10 ns

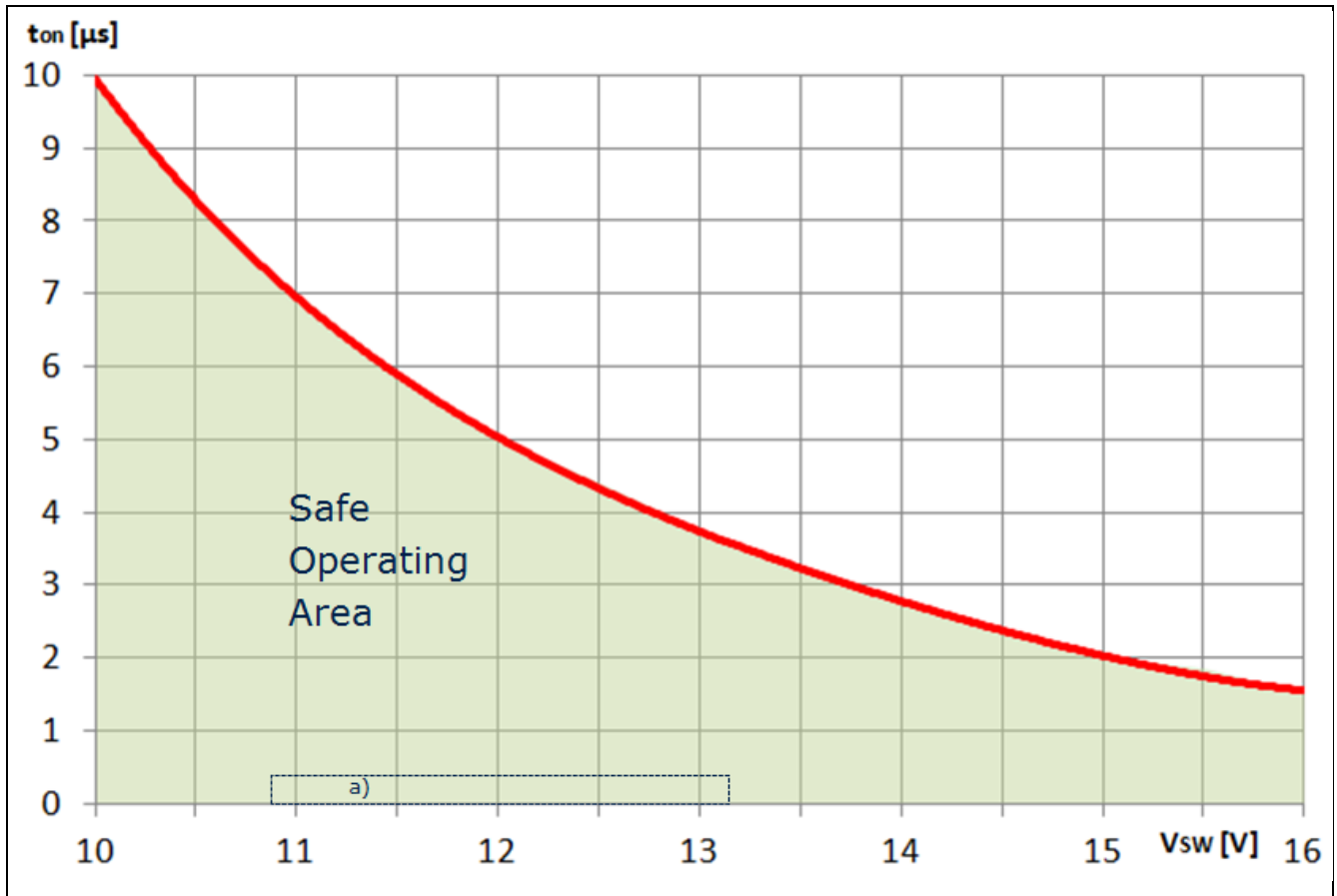

Figure 4 Repetitive Voltage Stress at Phase Node - Safe Operating Area

Note: t_{on} refers to the on-time of the HS-MOSFET. For input voltages below 10 V no limits on the duration of t_{on} need to be applied.

Information: a) - Area of typical computing applications with 12 V input supply voltage

4.2 Thermal Characteristics

Table 7 Thermal Characteristics

Parameter	Symbol	Values			Unit	Note / Test Condition
		Min.	Typ.	Max.		
Thermal resistance to case (soldering point)	θ_{JC}	–	3.5	–	K/W	–
Thermal resistance to top of package	θ_{JCtop}	–	3.7	–		–
Thermal resistance to ambient ($P_{loss} = 4.5\text{ W}$, $T_A = 70\text{ °C}$, 8 layer server board with 2 oz copper per layer)	θ_{JA}	–	14	–		Still air
		–	10	–		200 lfm airflow
		–	8	–	300 lfm airflow	

4.3 Recommended Operating Conditions and Electrical Characteristics³

Note: $V_{IN} = 12\text{ V}$, $V_{DRV} = V_{CIN} = 5\text{ V}$, $T_A = 25\text{ °C}$ unless otherwise specified

Table 8 Recommended Operating Conditions

Parameter	Symbol	Values			Unit	Note / Test Condition
		Min.	Typ.	Max.		
Input voltage	V_{IN}	4.5	–	16	V	–
MOSFET driver voltage	V_{DRV}	4.5	–	8	V	–
Logic supply voltage	V_{CIN}	4.5	–	8		–
Frequency of the PWM	f_{sw}	100	–	800	kHz	CCM operation with stated current sense accuracy
Junction temperature	T_{jOP}	-25	–	+125	°C	–

³ Exposure over values of the recommended ratings for extended periods may adversely affect operation and reliability of the device. Min/Max values are based on empirical Cpk.

Table 9 Voltage Supply And Biasing Current

Parameter	Symbol	Values			Unit	Note / Test Condition
		Min.	Typ.	Max.		
UVLO VCIN rising	V_{UVLO1_R}	3.0	–	4.0	V	Driver enable threshold; above threshold driver is active, driver responds to PWM input when UVLO VDRV and UVLO BOOT are enabled, TMON/FAULT reports driver temperature when UVLO VDRV is enabled
UVLO VCIN falling	V_{UVLO1_F}	2.6	–	3.6		Driver disable threshold; below threshold driver is inactive, PWM and TMON/FAULT held low by pull-down resistors
UVLO VDRV rising	V_{UVLO2_R}	4.16	4.25	4.34	V	GL, GH and TMON/FAULT enable threshold; when UVLO VCIN is enabled then: above threshold GL is enabled, GH depends on UVLO BOOT, TMON/FAULT is released to report driver temperature
UVLO VDRV falling	V_{UVLO2_F}	3.7	3.8	3.9		GL, GH and TMON/FAULT disable threshold; when UVLO VCIN is enabled: below threshold after 3 consecutive cycles or 15 μ s (typ.) the driver outputs GL/GH are disabled, TMON/FAULT stops temperature reporting and is held low by pull-down resistor
UVLO BOOT rising	$V_{UVLOboot_R}$	3.88	4.05	4.22	V	$V_{BOOT}-V_{SW}$ rising, GH enable threshold; when UVLO VCIN and UVLO VDRV are active: above threshold GH responds to PWM
UVLO BOOT falling	$V_{UVLOboot_F}$	3.5	3.63	3.76		$V_{BOOT}-V_{SW}$ falling, GL/GH disable threshold; when UVLO VCIN and UVLO VDRV are enabled: below threshold counter starts, after 3 consecutive PWM cycles driver outputs are disabled
Driver current	I_{VDRV_600kHz}	–	27	–	mA	OFF# = 3.3 V, $f_{SW} = 600$ kHz
	I_{VDRV_1MHz}	–	44	–		OFF# = 3.3 V, $f_{SW} = 1$ MHz
IC current (control)	I_{VCIN_O}	–	1.0	–	mA	OFF# = 3.3 V, PWM = Open for > 19 μ s (typ.)
IC quiescent	$I_{CIN}+I_{DRV}$	–	1.2	–		
Pre-Bias at SW	V_{SW_0}	–	120	160	mV	PWM in Tri-state (V_{PWM_S}), VCIN = VDRV = 5V, internal pull-down resistor 1.5 k Ω

Table 10 Current Sense

Parameter		Symbol	Values			Unit	Note / Test Condition	
			Min.	Typ.	Max.			
IMON	Voltage Range	V_{IMON}	0.8	–	2.2	V	IMONREF is a current mirror output serving as unfiltered reference node. At IMON a filtered voltage signal proportional to the current is provided. It tracks the average value of IMONREF.	
IMONREF	IMON gain resistor range	$R_{IMONREF}$	0.2	–	1.0	k Ω		
	Current sense gain ⁴	a_{CS}	-	6.67	-	$\mu A/A$		
	Leakage current	I_{Leak}	-2	0	2	μA	$I_D = 0, V_{CM} = 1.5, PWM$ in tri-state	
Current Monitoring	Zero current offset	I_{Offset}	-3	0	3	μA	Corresponds to 2.25 mV at 5 mV/A ($R_{IMONREF} = 750\Omega$), device in regulation	
	Accuracy at 25 °C ... 125 °C $V_{DRV} = 5 V \pm 10 \%$ $V_{CIN} = 5 V \pm 10 \%$	a11	-3	–	3	%	for 45 A < I_{out} < I_{OCtrip}	tested at 25 A, other guaranteed by design
		a12	-2.5	–	2.5	%	for 25 A $\leq I_{out} \leq$ 45 A	
		a13	-0.5	–	0.5	A	for -25 < I_{out} < 25 A	
a14		-20	–	20	%	for -50 A $\leq I_{out} \leq$ -25 A		

Table 11 Temperature Sense

Parameter		Symbol	Values			Unit	Note / Test Condition
			Min.	Typ.	Max.		
Temp. Sense and Accuracy	Temp. FAULT	T_{TMAX}	140	145	150	$^{\circ}C$	Temperature monitors driver junction. Circuit reports temperatures to -25 °C accurately (0.4V). The maximum temperature reported is T_{TMAX} . Above T_{TMAX} a logic 'H' is asserted to indicate a fault (latched). At OTP fault PWM input is suspended and driver is being set to tri-state mode until V_{CIN} and/or V_{DRV} have been re-cycled.
	Output high	V_{TMON_H}	2.6	–	–	V	
	Output monitor	V_{TMON}	0.4	–	1.8		
	Fault delay ⁵	$t_{TMONdeg}$	–	3	–	μs	
	Temp. range ⁵	T_{TMON}	-25	–	150	$^{\circ}C$	
	Temp. coefficient ⁵	TC	–	8	–	mV/K	
	Nominal	V_{25C}	–	800	–	mV	
	Accuracy at -25 °C ... 125 °C (tested at 25 °C, other guaranteed by design)	a_{TMON}	-4	–	4	K	unspecified below -25 °C

⁴ Guaranteed by design

⁵ Guaranteed by design

Table 12 Other Logic Functions, Inputs/Outputs And Thresholds

Parameter		Symbol	Values			Unit	Note / Test Condition
			Min.	Typ.	Max.		
OFF#	Input low	$V_{OFF\#_L}$	–	–	0.8	V	$V_{OFF\#}$ falling
	Input high	$V_{OFF\#_H}$	2.0	–	–		$V_{OFF\#}$ rising
PWM	Input low	V_{PWM_L}	–	–	0.8	V	V_{PWM} falling
	Input high	V_{PWM_H}	2.4	–	–		V_{PWM} rising
	Input resistance	R_{IN-PWM}	6	–	10	k Ω	$V_{PWM} = 1\text{ V}$
	Open voltage	V_{PWM_O}	–	1.6	–	V	V_{PWM_O}
	Tri-state shutdown window ⁶	V_{PWM_S}	1.2	–	2.0		–
	Min pulse width ⁵	$t_{PWMdetect}$	5	–	10	ns	Minimum pulse width to detect PWM pulse
	Min pulse time ⁵	t_{PWMmin}	–	30	–	ns	PWM pulses shorter than t_{PWMmin} will be extended to t_{PWMmin}
OCP	Overcurrent Protection	$I_{OCPtrip}$	68	75	82	A	Duty cycle limitation at $I_{OCPtrip}$, fault asserted and latched after 10 truncated consecutive switching cycles
HSS	High-Side-Short Protection	$V_{HSStrip}$	–	0.83	–	V	Voltage tested at phase node during LS-MOSFET on-time. If voltage exceeds $V_{HSStrip}$, fault is asserted and latched.

Table 13 Timing Characteristics⁷

Parameter	Symbol	Values			Unit	Note / Test Condition
		Min.	Typ.	Max.		
PWM tri-state to SW falling delay	t_{pts2}	–	16	–	ns	V_{OUT} prebiased at 1 V, other conditions as for t_{pts}
PWM tri-state to SW rising delay	t_{pts}	–	19	–	ns	$I_{LOAD} = 0$, $V_{DRV} = V_{CIN} = 5\text{ V}$, $V_{IN} = 12\text{ V}$, $f_{sw} = 600\text{ kHz}$
PHASE Shutdown Hold-Off time from PWM low	t_{tsshd}	–	41	–		
PHASE Shutdown Hold-Off time from PWM high	t_{tssh}	–	45	–		
PWM to SW Turn-off propagation delay	t_{pdlu}	–	31	–		
PWM to SW Turn-on propagation delay	t_{pdll}	–	21	–		
OFF# Turn-off propagation delay falling	$t_{pd_OFF\#}$	–	17	–	ns	
OFF# Turn-on propagation delay rising	$t_{pdh_OFF\#}$	–	25	–		

Corresponding diagrams can be found under section “Gate Driver Timing Diagram”.

⁶ Maximum voltage range for tri-state

⁷All timing data are guaranteed by design

5 Theory of Operation

The TDA21320 features a power stage with MOSFET driver. Temperature and current are being monitored. Data and various fault conditions can be reported to the controller.

The power MOSFETs are optimized for 5 V gate drive enabling excellent high load and light load efficiency. The gate driver is a robust high-performance driver rated at the switching node for DC voltages ranging from -1 V to +18 V.

5.1 Driver Characteristics

The gate driver has 2 voltage inputs, VCIN and VDRV. VCIN is the 5 V logic supply for the driver. VDRV sets the driving voltage for the high-side and low-side MOSFETs. The reference for the gate driver control circuit (VCIN) is CGND. To decouple the sensitive control circuitry (logic supply) from a noisy environment a ceramic capacitor must be placed between VCIN and CGND close to the pins. VDRV needs also to be decoupled using a ceramic capacitor (MLCC) between VDRV and PGND in close proximity to the pins. PGND serves as reference for the power circuitry including the driver output stage.

5.2 Power-Up Sequence

Without the logic supply VCIN the device remains off. PWM is held low by an internal pull down resistor. PWM information cannot be fed to the driver. VCIN supplies power to the driver logic. With the presence of VCIN on power-up of the gate drive voltage VDRV, the driver and the PWM input will be enabled, the unforced PWM level will be within its tri-state window. This signals that the driver supply voltages have cleared their respective UVLO thresholds. TMON/FAULT reports temperature. The PWM controller is expected to wait for this to happen before initiating PWM signals to start up the system.

Note that with VCIN and VDRV present, the switching node can rise up to V_{SW_0} with PWM in tri-state condition.

5.3 Inputs to the Internal Control Circuits

PWM is the control input to the IC from an external PWM controller and is compatible with 3.3 V logic. The PWM input has tri-state functionality. When the voltage remains in the specified PWM-shutdown-window for at least the PWM-shutdown-holdoff time t_{tsshd} , the operation will be suspended by keeping both MOSFET gate outputs low. Once left open, the pin is held internally at a tri-state level of V_{PWM_O} . The PWM signal must prevail for at least t_{PWMmin} to initiate a response from the driver.

The PWM threshold voltages V_{PWM_O} , V_{PWM_H} , V_{PWM_L} do not vary over the wide range of VCIN supply voltages (4.5 V to 8 V).

The **OFF#** pin provides a means to keep the low-side MOSFET disabled regardless of the PWM signal. It is an active low signal. An internal pull up resistor ensures regular operation when the pin is not used.

When pulled low, the low-side MOSFET is kept in off-state. In multiphase systems the OFF# pins of all phases may be connected together. One controller output is then able to toggle the LS-FET operation mode.

Table 14 PWM and OFF# Pin Functionality, Driver Outputs

PWM logic level	OFF# logic level	Gate HS-FET (GH)	Gate LS-FET (GL)
High	Any	High	Low
Open (Tri-state: left floating, or high impedance)		Low	
Low	Low	Low	High
	High or open		

5.4 Monitoring and Protection Circuits

The TDA21320 is designed with the various protection functions. Most of these protection features require a PWM controller that reacts properly on the assertion of a fault signal at TMON/FAULT to shutdown the circuit. Fault assertion is latched and is being removed when VCIN and/or VDRV will be re-cycled. A reported fault is always indicating a critical condition with high stress levels on the device and/or load that requires immediate action in form of shutdown to prevent imminent catastrophic failure.

In multiphase regulators the TMON/FAULT outputs of the power stages will have to be connected together. The TMON/FAULT output voltage follows the highest voltage output of any phase connected. The pull-down capability of any TMON/FAULT output is weak so that a fault assertion of any phase will always override other phase outputs.

5.4.1 High-Side Short Protection (HSS)

The voltage at the switching node is being monitored during the LS-MOSFET being driven in on-state. When during that time the switching node voltage exceeds a critical threshold of $V_{HSStrip}$ the HSS fault is being asserted by pulling TMON/FAULT to 'high'. The PWM controller has to shut down the power stage to prevent catastrophic failure. TMON/FAULT is latched and will be released when VCIN and/or VDRV will be re-cycled.

HSS can lead to a very sudden current rise that can impact voltage potentials in and in vicinity of the power device so that early reset events could potentially occur. Therefore, it is important to always have the system controller terminate the power supply as soon as a critical event has been reported by the power stage.

5.4.2 Thermal Protection and Temperature Monitoring

The driver monitors and reports its temperature. In multiphase systems with connected TMON/FAULT pins only the highest temperature of any of the connected phases will be reported. The PWM controller is supposed to react on the reported temperature with power throttling commands to the load. If the system fails to respond and the temperature continues to rise to a value of T_{TMAX} for at least $t_{TMONdeg}$, TMON/FAULT is being pulled high to report an Over-Temperature Fault (OTP). TMON/FAULT is latched and will be released when VCIN and/or VDRV will be re-cycled. At OTP fault the driver outputs will be deactivated until VCIN and/or VDRV have been re-cycled.

The PWM controller is expected to shut down the power stage to prevent catastrophic failure.

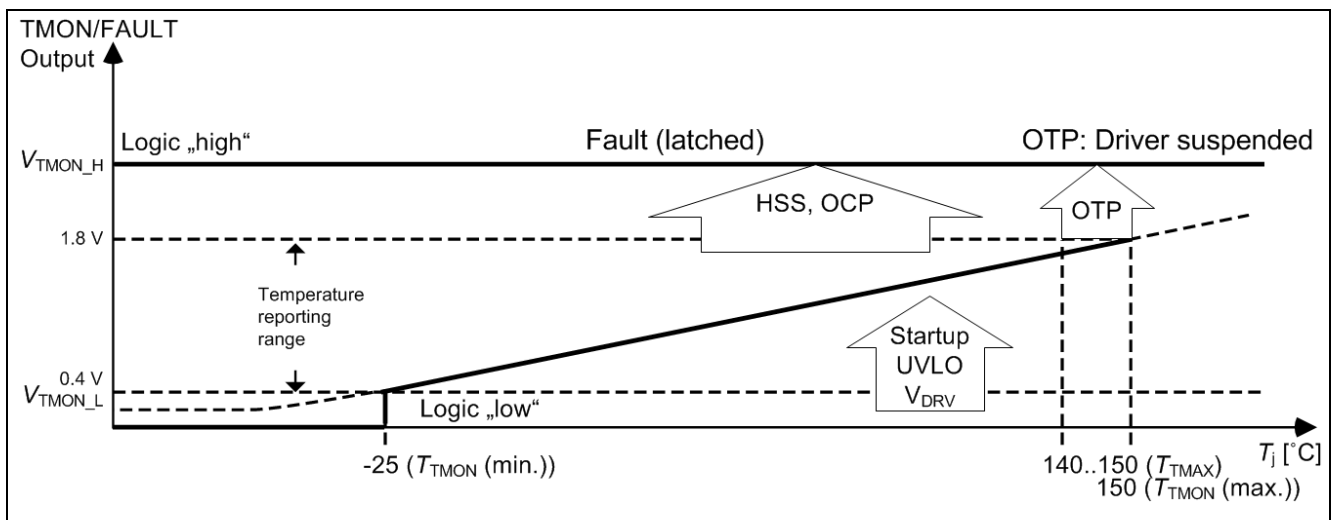

Figure 5 Thermal monitoring and protection

Note: Temperature reporting below T_{TMON_min} occurs with limited accuracy. T_{TMON_min} is being defined by the corresponding controller detection threshold for logic 'L'.

The reported voltage as function of temperature follows this equation:

$$V_{TMON} = 0.6V + 8mV/K \cdot T(^{\circ}C) \tag{1}$$

5.4.3 Undervoltage Lockout (UVLO)

The power stage should not be operated when its supply voltages are out of the nominal range. UVLO conditions occurring during power up and power down must be accommodated by proper sequencing. An UVLO condition under normal operation can indicate a problem with the driver voltage and must be handled with a shutdown to prevent damage to the power stage.

A primary UVLO circuit monitors VCIN. Only after having VCIN in regulation range the UVLO monitoring on VDRV takes place. During startup UVLO on VDRV is being signaled by keeping TMON/FAULT low.

With VCIN being below V_{UVLO1_R} at startup the driver is inactive, PWM and TMON/FAULT are held low.

When VCIN exceeds V_{UVLO1_R} the driver becomes active, pin PWM is being enabled as input and held internally at its tri-state level of V_{PWM_O} . Then VDRV determines TMON/FAULT:

- Below V_{UVLO2_R} TMON/FAULT remains 'low'.
- When VDRV exceeds V_{UVLO2_R} TMON/FAULT is released and reports temperature.
- When VDRV falls below V_{UVLO2_F} for 3 consecutive cycles or 15 μ s (typ.) TMON/FAULT is being pulled 'low'.

If at startup VCIN and/or VDRV are below their respective undervoltage lockout rising thresholds (V_{UVLO1_R} , V_{UVLO2_R}) GL and GH remain disabled. Once these thresholds have been cleared, the driver provides GL output signal following PWM. When the voltage $V_{BOOT}-V_{SW}$ has been exceeding $V_{UVLOboot_R}$, GH is being released to respond to PWM.

When VCIN and/or VDRV are falling below their respective undervoltage lockout falling thresholds (V_{UVLO1_F} , V_{UVLO2_F}) the driver disables its outputs GH and GL to drive the MOSFETs.

When the voltage $V_{BOOT}-V_{SW}$ has been falling below $V_{UVLOboot_F}$ for three consecutive PWM cycles the driver will be disabled.

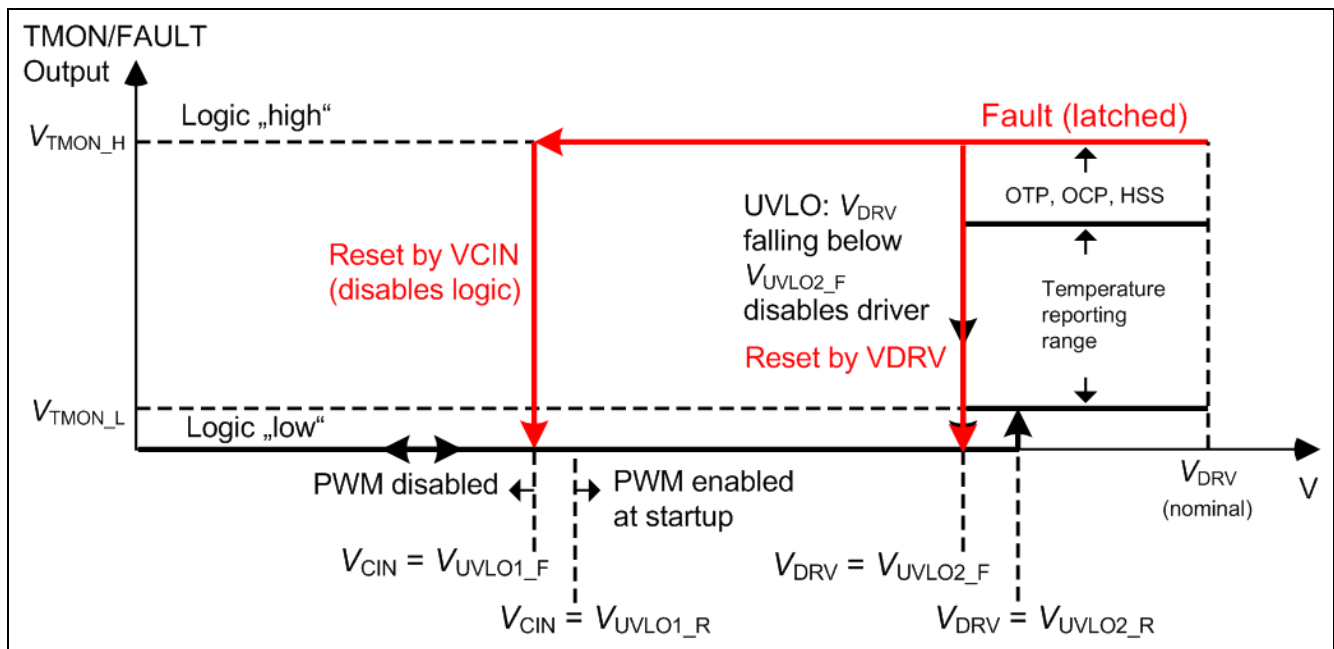

Figure 6 Output Signal at TMON/Fault

5.4.4 BOOT - Undervoltage Protection (UVLO_{BOOT})

The voltage between BOOT and SW pins (boot-voltage) is being monitored when VCIN and VDRV have been clearing their respective UVLO conditions. At startup, the LS-MOSFET gate (GL) is enabled to respond to the PWM signal when VDRV is being active. If the voltage at the boot capacitor is insufficient to clear the $V_{UVLOboot_R}$ threshold, GH remains disabled until the active LS-MOSFET has forced sufficient charge onto the boot capacitor during the PWM “L” state. When the boot capacitor voltage exceeds $V_{UVLOboot_R}$, the GH output for the gate drive of the HS-MOSFET is enabled.

At startup and anytime when the boot voltage is below $V_{UVLOboot_F}$ an internal boot-error flag is set. The boot-error flag is being reset when the boot voltage exceeded $V_{UVLOboot_R}$.

If during the falling edge of the PWM (from ‘H’ to tri-state or from ‘H’ to ‘L’) the UVLO_{BOOT} error flag is set, an internal counter increases by one. When the counter reaches three, the driver outputs GH/GL are being disabled (i.e. latched in tri-state), regardless of the PWM input.

To reset the driver and resume operation, the PWM input has to be held in tri-state for 19 μ s (typ). After that, the UVLO_{BOOT} counter is being reset to zero and the driver performs a startup sequence as described before in order to bring sufficient charge onto the boot capacitor.

The UVLO_{BOOT} counter is also being reset to zero whenever during the falling edge of the PWM the UVLO_{BOOT} error flag was not set, i.e. the error condition had been temporary for less than three consecutive instances of the falling edge of the PWM signal.

To prevent depletion of the boot capacitor during extended time in tri-state during regular operation, a boot refresh circuit will engage after 19 μ s (typ) in consecutive tristate condition when the voltage at the boot capacitor has fallen below $V_{UVLOboot_F}$. This circuit remains active until $V_{UVLOboot_R}$ has been reached or the PWM input signal leaves the region of tri-state. The boot refresh circuit is powered by V_{IN} . To ensure full effectiveness the voltage difference ($V_{IN} - V_{SW}$) should be more than 4.8 V.

If the driver was disabled due to an UVLO_{BOOT} error, it will be reset to resume operation when VCIN and/or VDRV will be re-cycled or PWM will be held at tri-state level for more than 19 μ s (typ).

In case of an UVLO_{BOOT} error it is expected that the system controller discovers a missing phase, phase current mismatch, excessive temperature or OCP events on other phases and initiates shutdown.

5.4.5 Current Monitoring and Overcurrent Protection (OCP)

The TDA21320 senses and reports current back to the controller via the voltage at IMON. This voltage is a filtered representation of the voltage at IMONREF. IMONREF is a current source output:

$$I_{IMONREF} = I_{OUT} \cdot a_{CS} \quad (2)$$

The voltage at IMONREF depends on the impedance its current is being passed through. A recommended target voltage at zero output current is 1.5V (common mode voltage). The series resistor $R_{IMONREF}$ between IMONREF and the common mode voltage reference sets the voltage gain of the current sense according to:

$$V_{IMONREF} = V_{IMONREF_CM} + R_{IMONREF} \cdot I_{IMONREF} \quad (3)$$

The output current is now represented by the voltage difference between IMON and $V_{IMONREF_CM}$. $V_{IMONREF_CM}$ is the voltage at IMONREF when the load current is zero.

$$V_{IMON} - V_{IMONREF_CM} = I_{OUT} \cdot R_{IMONREF} \cdot a_{CS} \quad (4)$$

a_{CS} is given in 0 for $VDRV = 5V$. If $VDRV$ has been chosen to be different, a_{CS} has to be calculated as:

$$a_{CS} = 6.67 \frac{\mu A}{A} \cdot (1 + (VDRV[V] - 5) \cdot 0.012) \quad (5)$$

A filter capacitor C_{IMON} of 10 pF has to be placed between IMON and $V_{IMONREF_CM}$ (reference voltage pin of $R_{IMONREF}$). C_{IMON} and $R_{IMONREF}$ have to be arranged in a tight loop close to the pins of the TDA21320. An additional resistor R_{IMON} has to be connected in parallel to C_{IMON} . Its location is flexible and can also be at the controller. The value for R_{IMON} should be chosen identical to $R_{IMONREF}$ within the range of 200 Ω to 1 k Ω .

At the voltage receiver side the measurement loop has to be closed. It is important to not inject noise into this loop. Therefore differential routing of IMON and IMONREF is required.

For example, having a permissible 500 mV voltage range at the receiver side to report positive current of 100 A, the resistor that has to be used in the IMONREF path can be calculated as:

$$V_{IMON} - V_{IMONREF_CM} = 500mV$$

$$R_{IMONREF} = \frac{V_{IMON} - V_{IMONREF_CM}}{I_{OUT} \cdot a_{CS}} = \frac{500mV}{100A \cdot 6.67 \cdot 10^{-6}} = 750\Omega \quad (6)$$

Having a resistor value of 348 Ω will result in the following voltage difference:

$$V_{IMON} - V_{IMONREF_CM} = R_{IMONREF} \cdot I_{OUT} \cdot a_{CS} = 348\Omega \cdot 100A \cdot 6.67 \cdot 10^{-6} = 232mV \quad (7)$$

The sensing of current occurs in the HS-MOSFET and the LS-MOSFET during their respective on-times. During tri-state condition both MOSFETs are in off-state without sensing. The current reported is then zero. If the tri-state condition was present for more than 19 μs (typ.), current reporting resumes with a delay of 1 μs (typ.).

OCP: By design of the application the current should never exceed the OCP tripping threshold $I_{OCPtrip}$. The duty cycle is being truncated by the TDA21320 when the current exceeds $I_{OCPtrip}$. This prevents the part from being destroyed by excessive current. A counter is being increased counting consecutive PWM duty cycle truncations. The counter is being reset at the first non-truncated PWM duty cycle. When the counter reaches the value of 10, a fault will be reported at TMON/FAULT by pulling it to 'high' level signaling the PWM controller the need for immediate action to prevent catastrophic failure. This fault is latched and will be released when VCIN and/or VDRV are being re-cycled.

5.4.6 Shoot Through Protection

The TDA21320 driver includes gate drive functionality to protect against shoot through. In order to protect the power stage from overlap, both high-side and low-side MOSFETs being on at the same time, the adaptive control circuitry monitors specific voltages. When the PWM signal transitions to low, the high-side MOSFET will begin to turn-off after the propagation delay time t_{pdlu} . When V_{GS} of the high-side MOSFET is discharged below 1 V (a threshold below which the high-side MOSFET is off), a secondary delay t_{pdhl} is initiated. After that delay the low-side MOSFET turns on regardless of the state of the "PHASE" pin. It ensures that the converter can sink current efficiently and the bootstrap capacitor will be refreshed appropriately during each switching cycle. See Figure 9 for more detail.

6 Application

6.1 Implementation

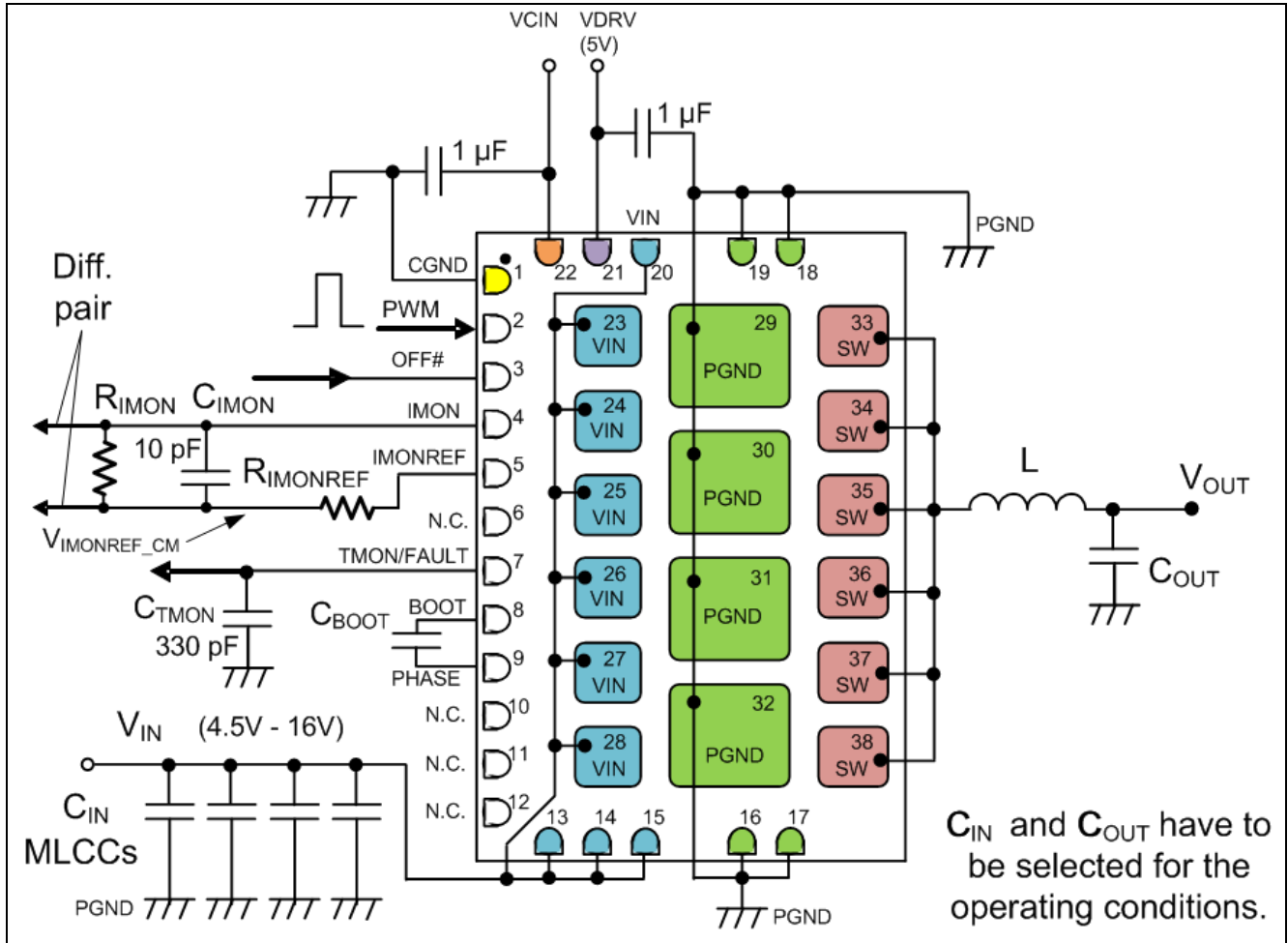

Figure 7 Pin Interconnection Outline (transparent top view)

Note:

1. Pin 9 (PHASE) is internally connected to the SW pads 33-38.
2. The capacitor C_{TMON} is used to filter noise from the TMON/FAULT connection. The capacitor has to be placed at the input of the controller. Its value should be set between 0.1 nF and 0.5 nF.
3. R_{IMON} should be chosen identical to $R_{IMONREF}$.
4. C_{IMON} and $R_{IMONREF}$ have to be arranged in a tight loop close to the pins of the TDA21320.
5. To lower the pre-bias voltage at V_{out} to below V_{SW_0} , place a resistor from V_{out} to GND.
6. C_{IN} should consist of a 0.1 μF and a 1 μF very close to the pins 15/16 and a 1 μF capacitor at pins 19/20. In addition place sufficient MLCCs in relative proximity of each power stage to deliver energy for the on-time of the HS-MOSFET.
7. The value of capacitor C_{BOOT} should be chosen according to the corresponding application note.

6.2 Typical Application

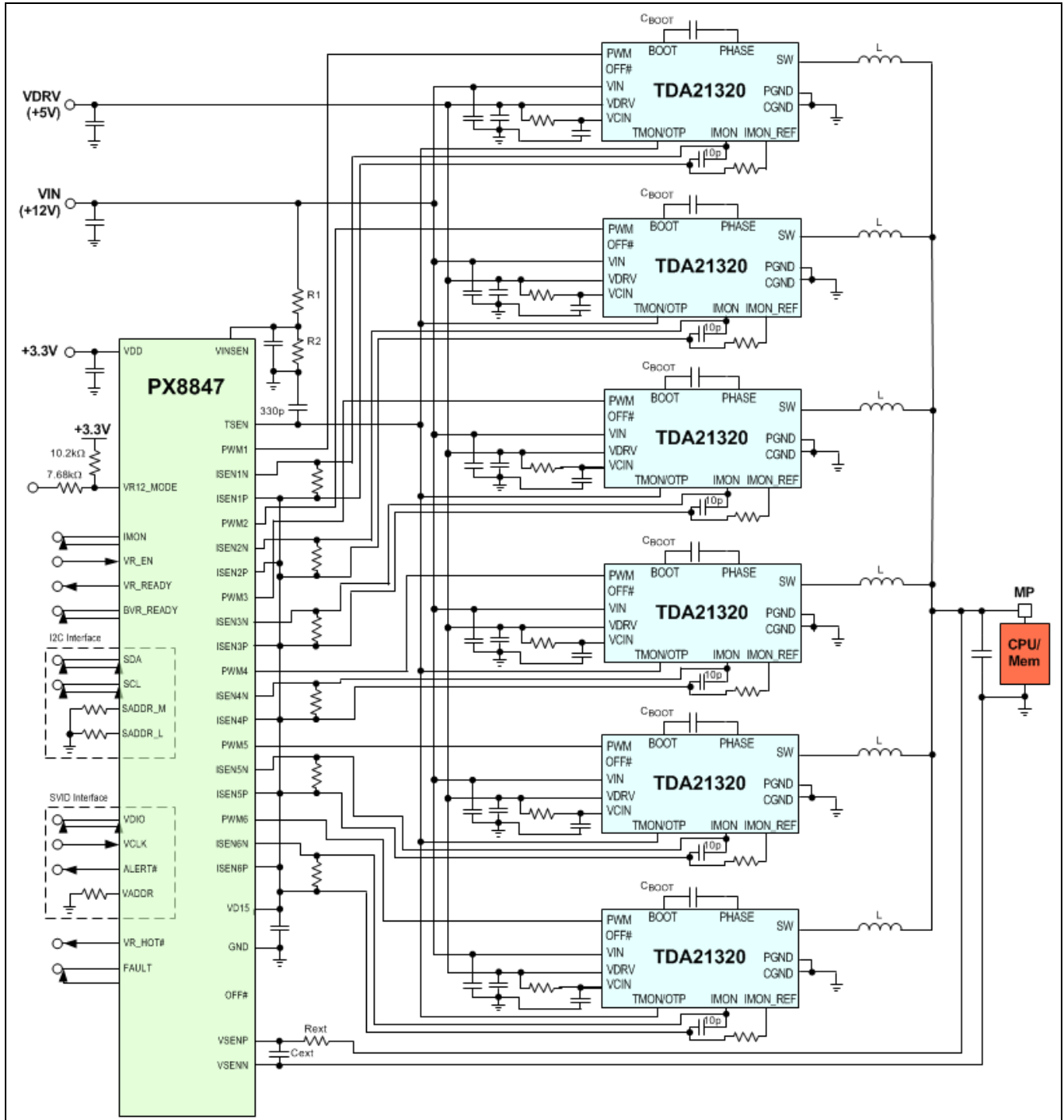

Figure 8 Six-phase voltage regulator - typical application (simplified schematic)

7 Gate Driver Timing Diagram

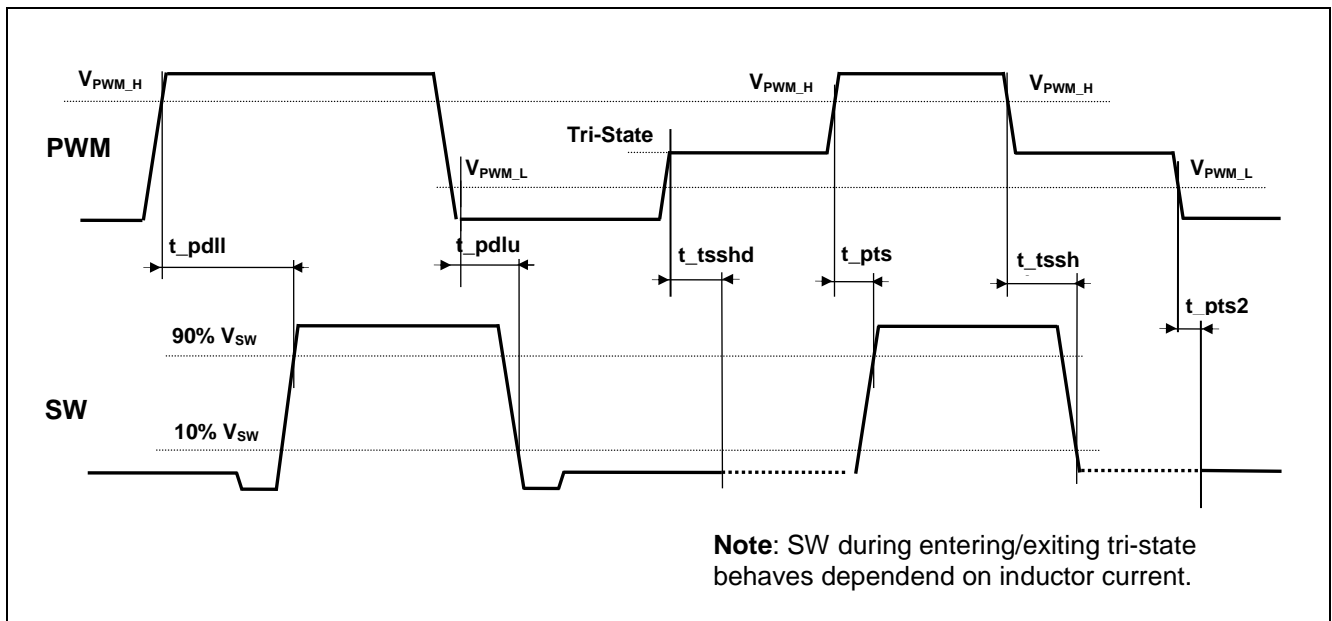

Figure 9 Adaptive Gate Driver Timing Diagram

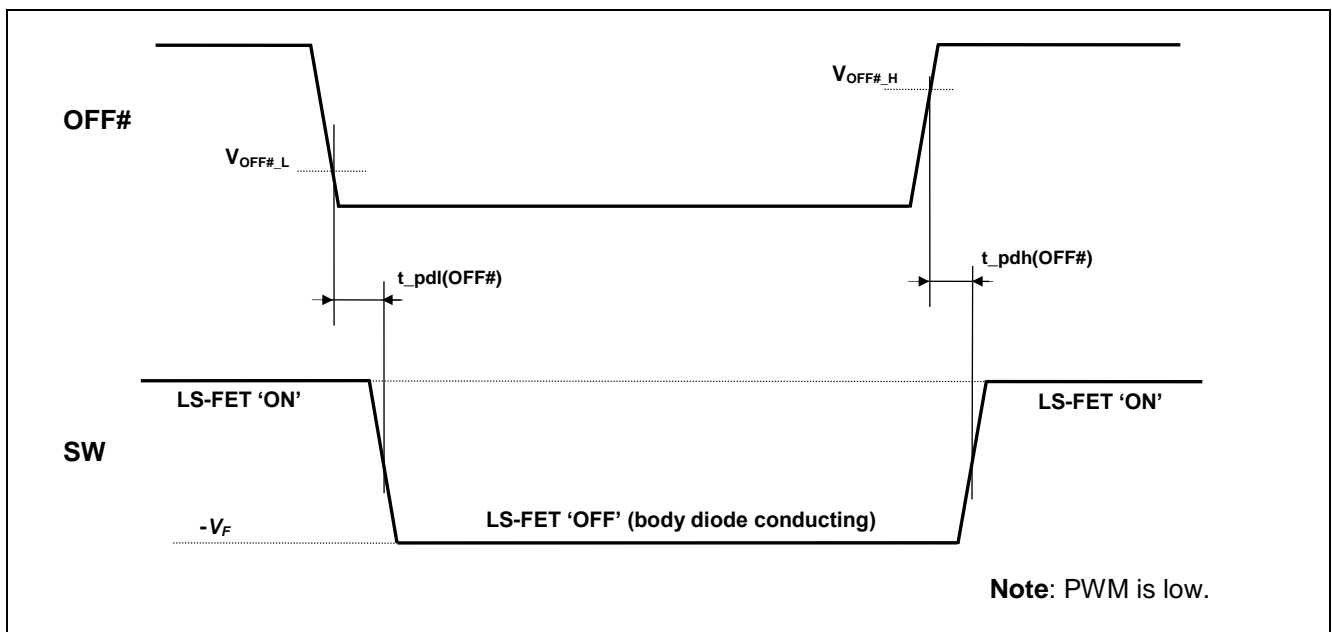

Figure 10 OFF# Timing Diagram

8 Performance Curves – Typical Data

Operating conditions (unless otherwise specified): $V_{IN} = +12\text{ V}$, $V_{CIN} = V_{DRV} = +5\text{ V}$, $V_{OUT} = +1.8\text{ V}$, $f_{sw} = 750\text{ kHz}$, 180 nH (Delta, HCB118080D-181, $DCR = 0.19\text{ m}\Omega$) inductor, $T_A = 25\text{ }^\circ\text{C}$, airflow = 200 LFM, no heatsink. Efficiency and power loss reported herein include only TDA21320 losses.

8.1 Driver Current versus Switching Frequency

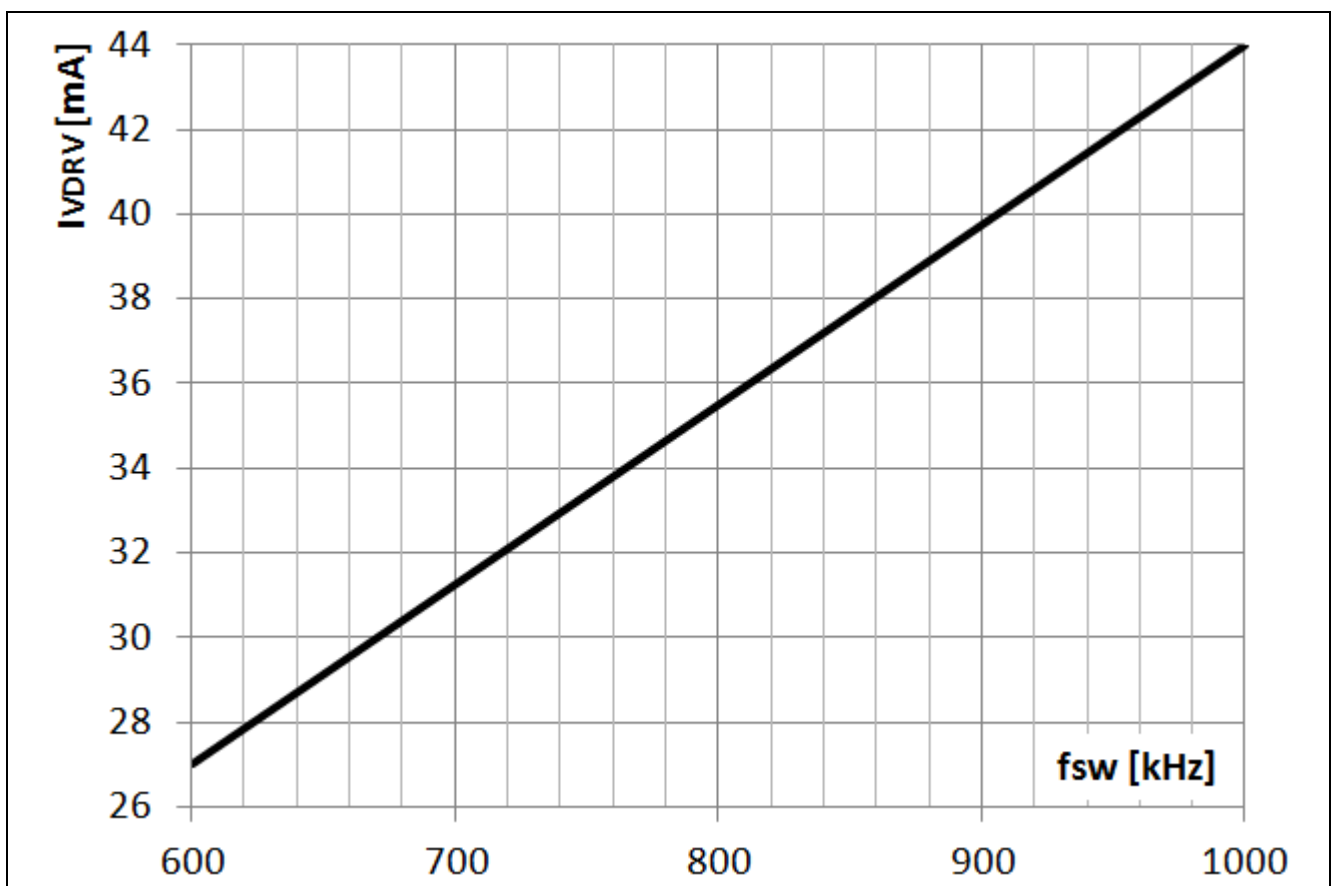

Figure 11 Driver Current over Switching Frequency in CCM Operation

8.2 Efficiency and Power Loss versus Output Voltage

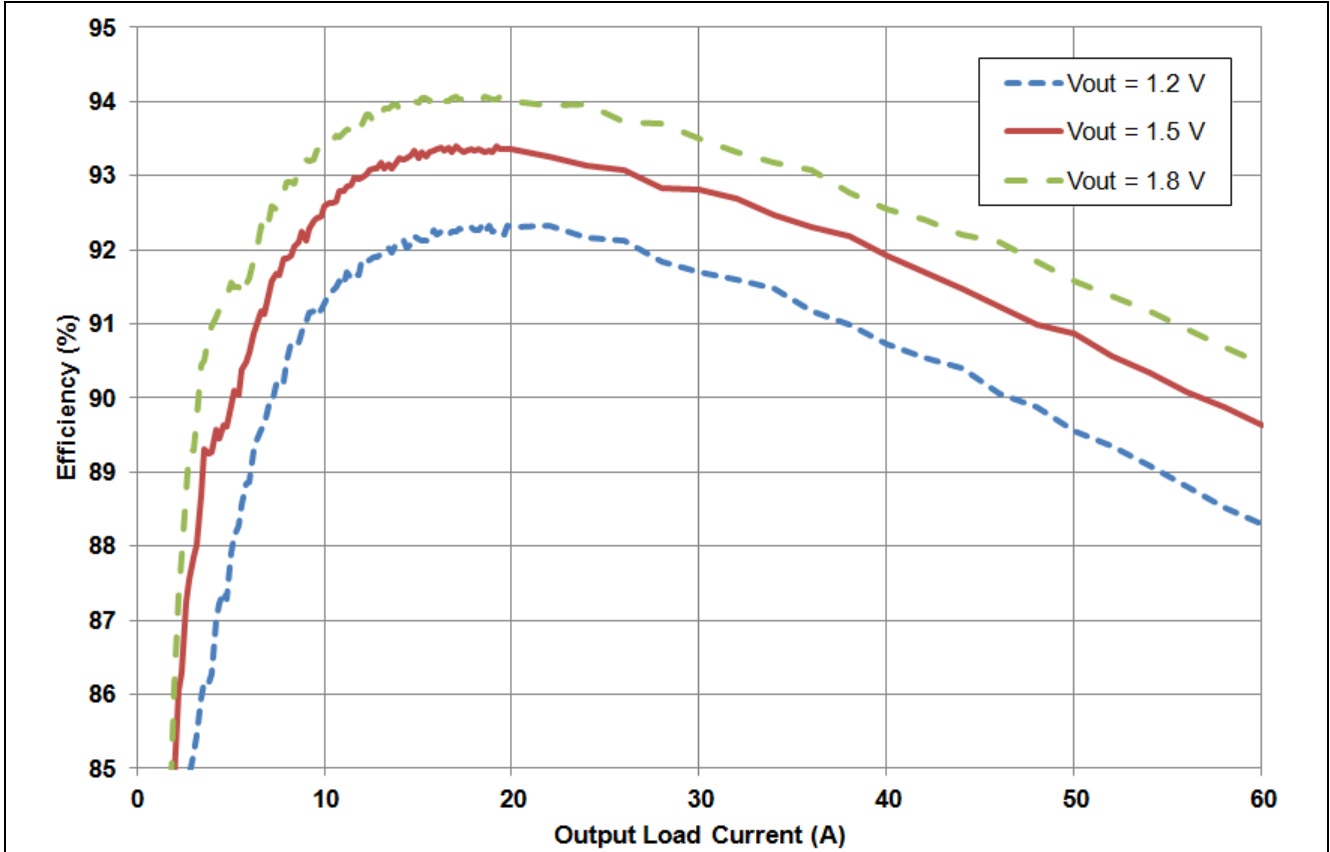

Figure 12 Efficiency at VIN = 12 V, VCIN = VDRV = 5 V, f_{sw} = 750 kHz, Parameter: VOUT

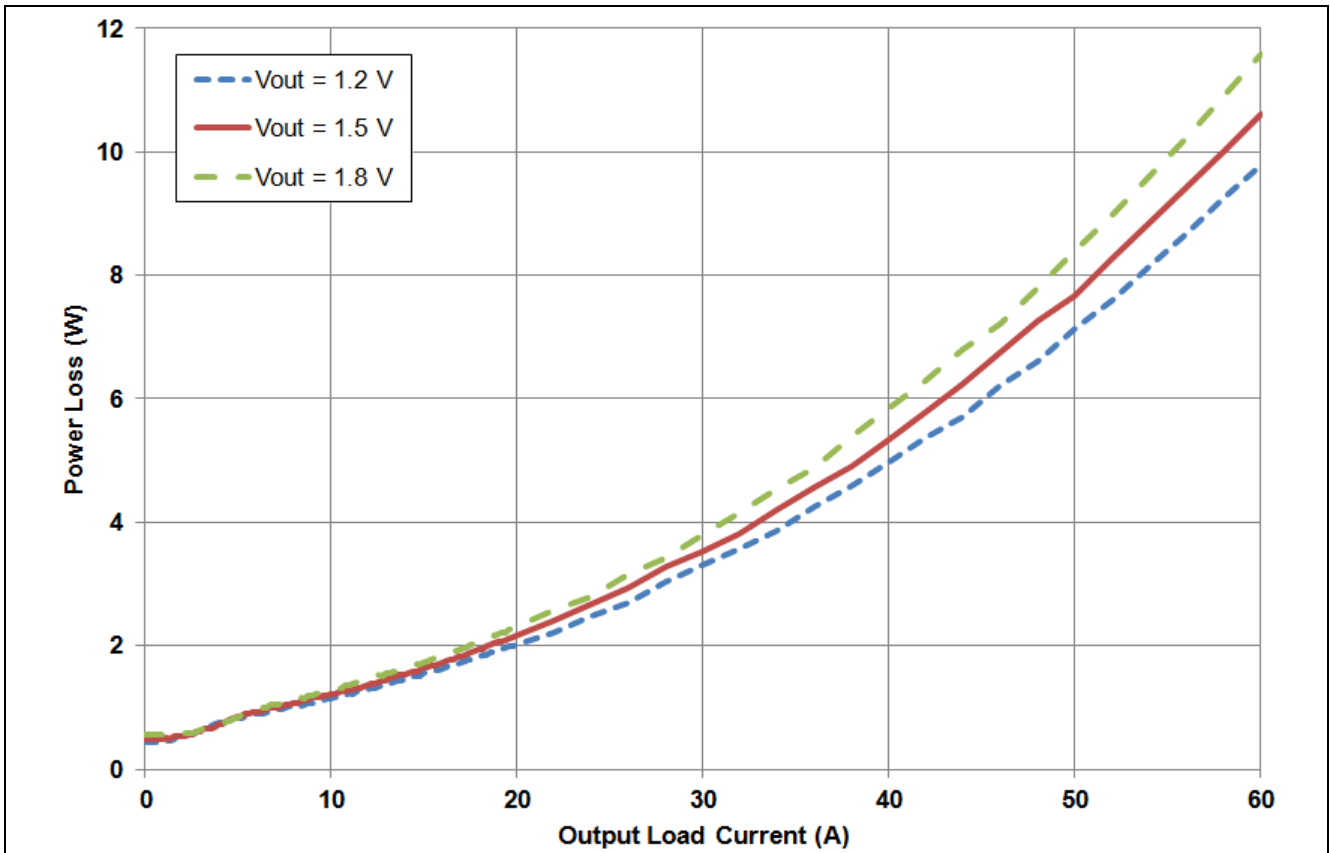

Figure 13 Power Loss at VIN = 12 V, VCIN = VDRV = 5 V, f_{SW} = 750 kHz, Parameter: VOUT

8.3 Efficiency and Power Loss versus Input Voltage

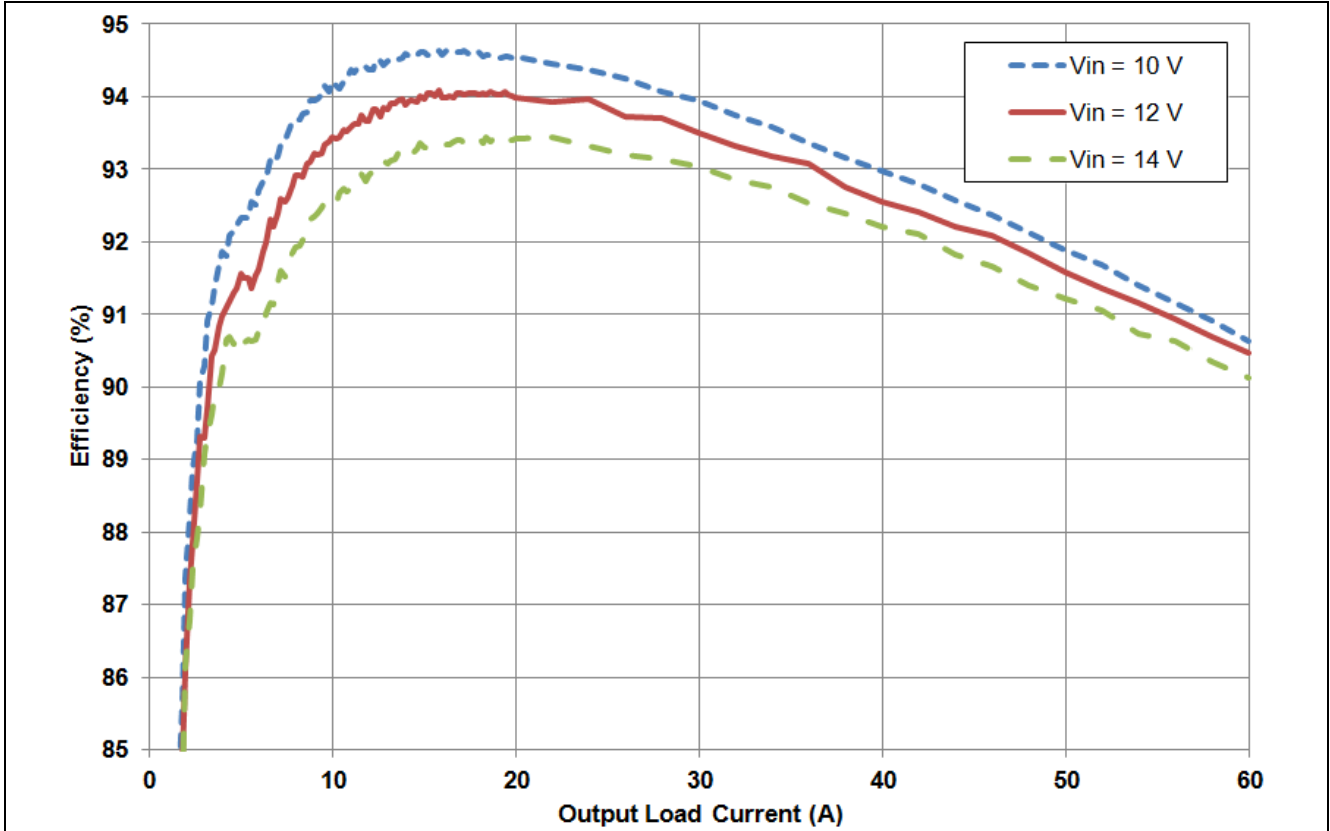

Figure 14 Efficiency at $f_{sw} = 750 \text{ kHz}$, $V_{CIN} = V_{DRV} = 5 \text{ V}$, $V_{OUT} = 1.8 \text{ V}$, Parameter: VIN

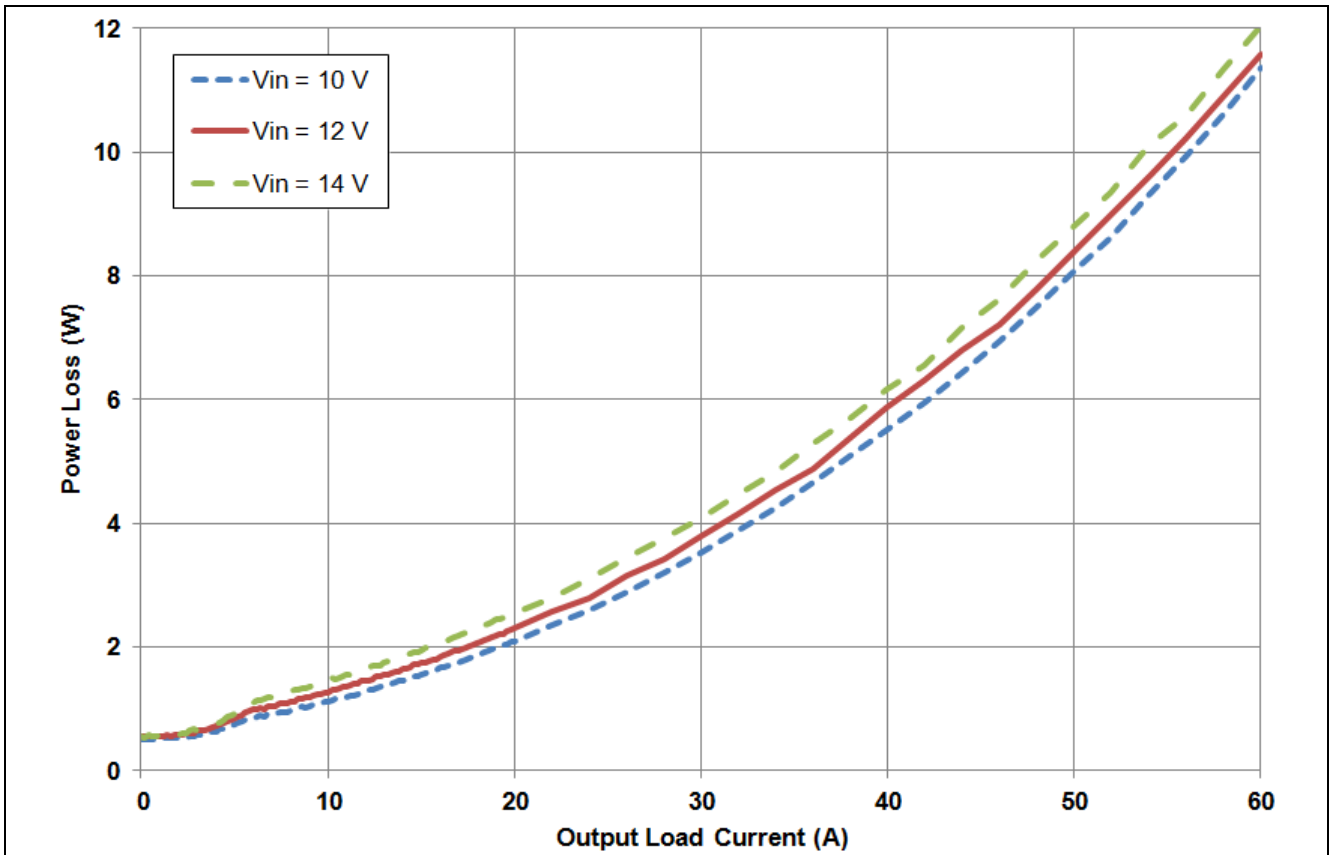

Figure 15 Power Loss at $f_{sw} = 750 \text{ kHz}$, $V_{CIN} = V_{DRV} = 5 \text{ V}$, $V_{OUT} = 1.8 \text{ V}$, Parameter: VIN

8.4 Efficiency and Power Loss versus Switching Frequency

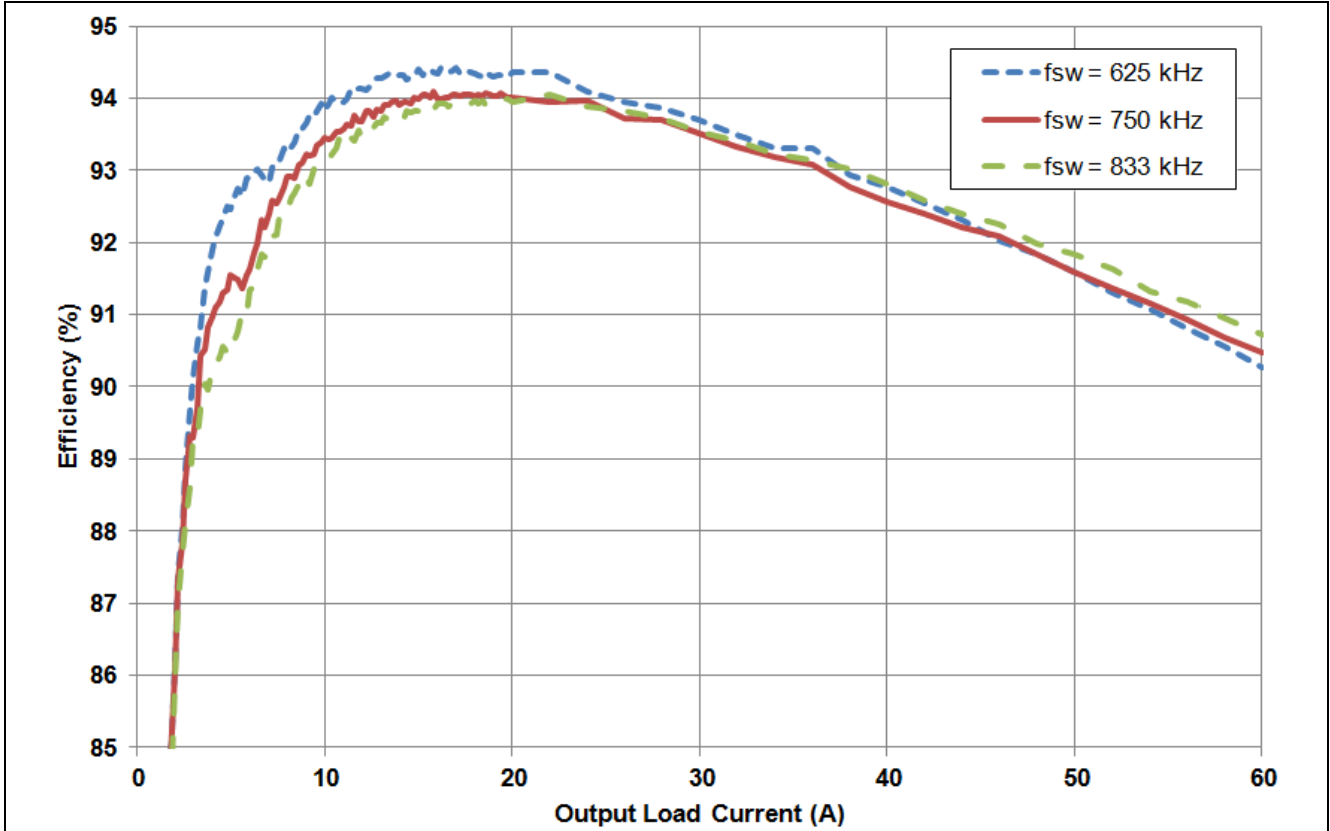

Figure 16 Efficiency at VIN = 12 V, VCIN = VDRV = 5 V, VOUT = 1.8 V, Parameter: fsw

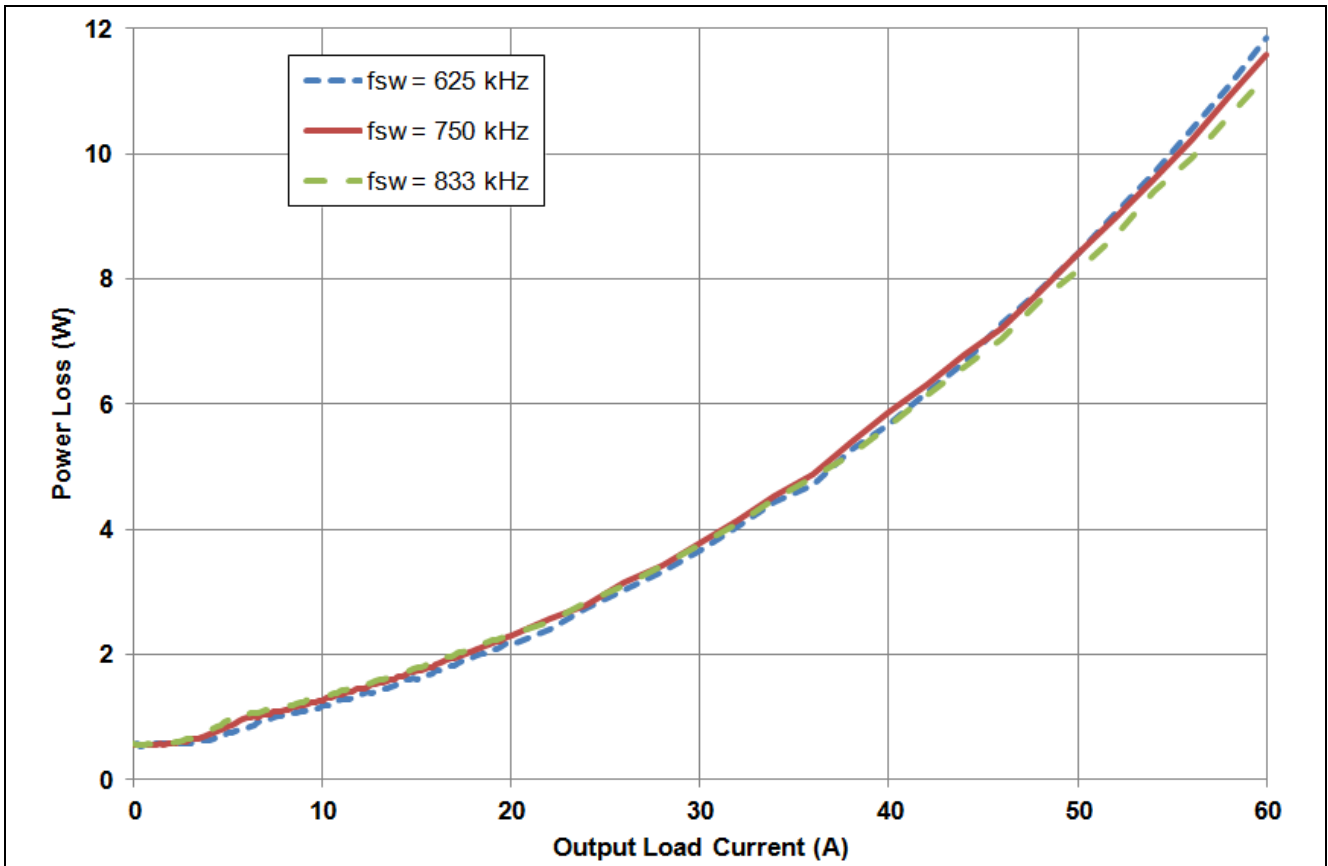

Figure 17 Power Loss at VIN = 12 V, VCIN = VDRV = 5 V, VOUT = 1.8 V, Parameter: f_{sw}

9 Mechanical Drawing LG-WIQFN-38-1 (6.6x4.5x0.6 mm³)

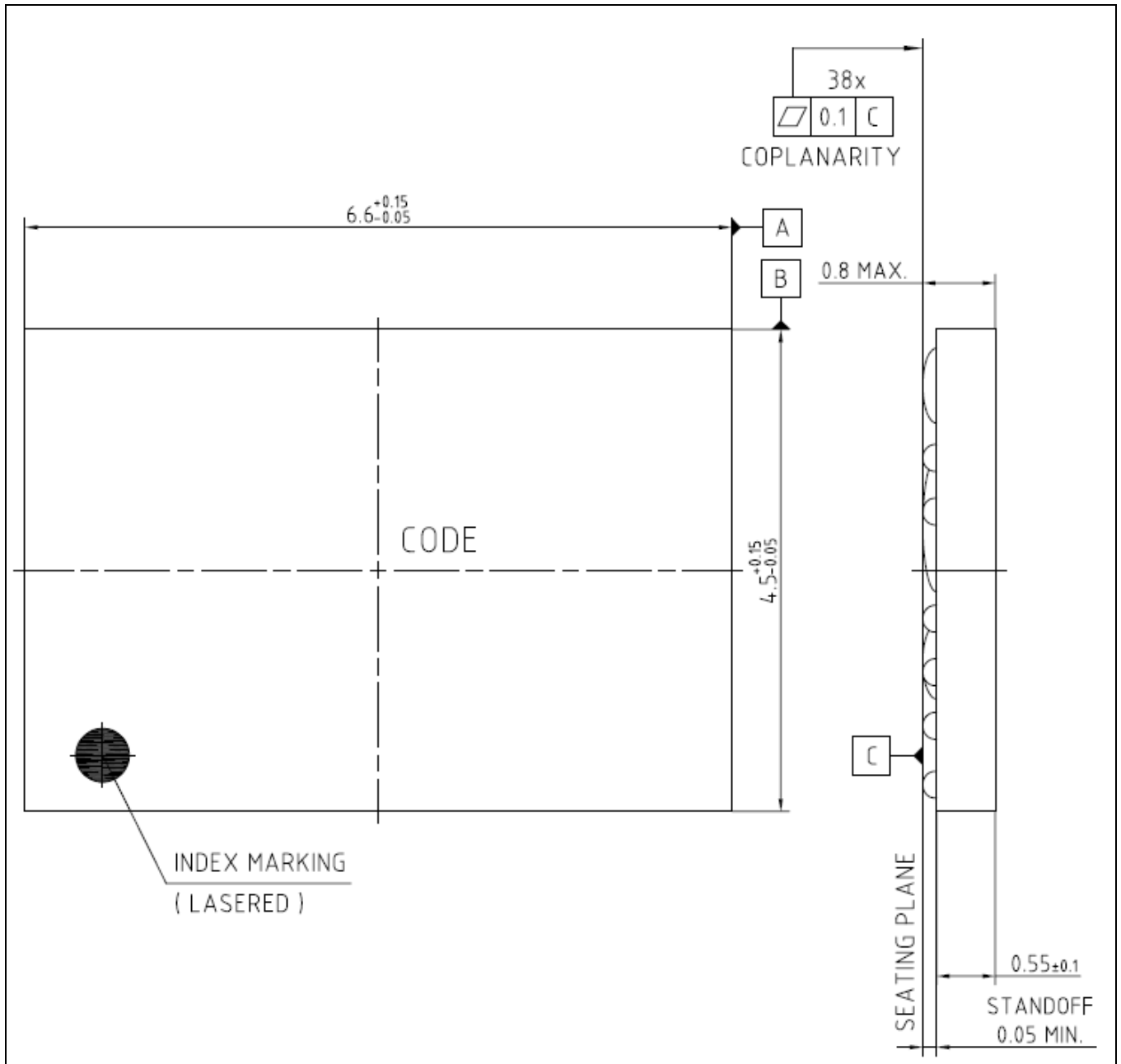

Figure 18 Mechanical Dimensions of Package (Top and Side View) in mm

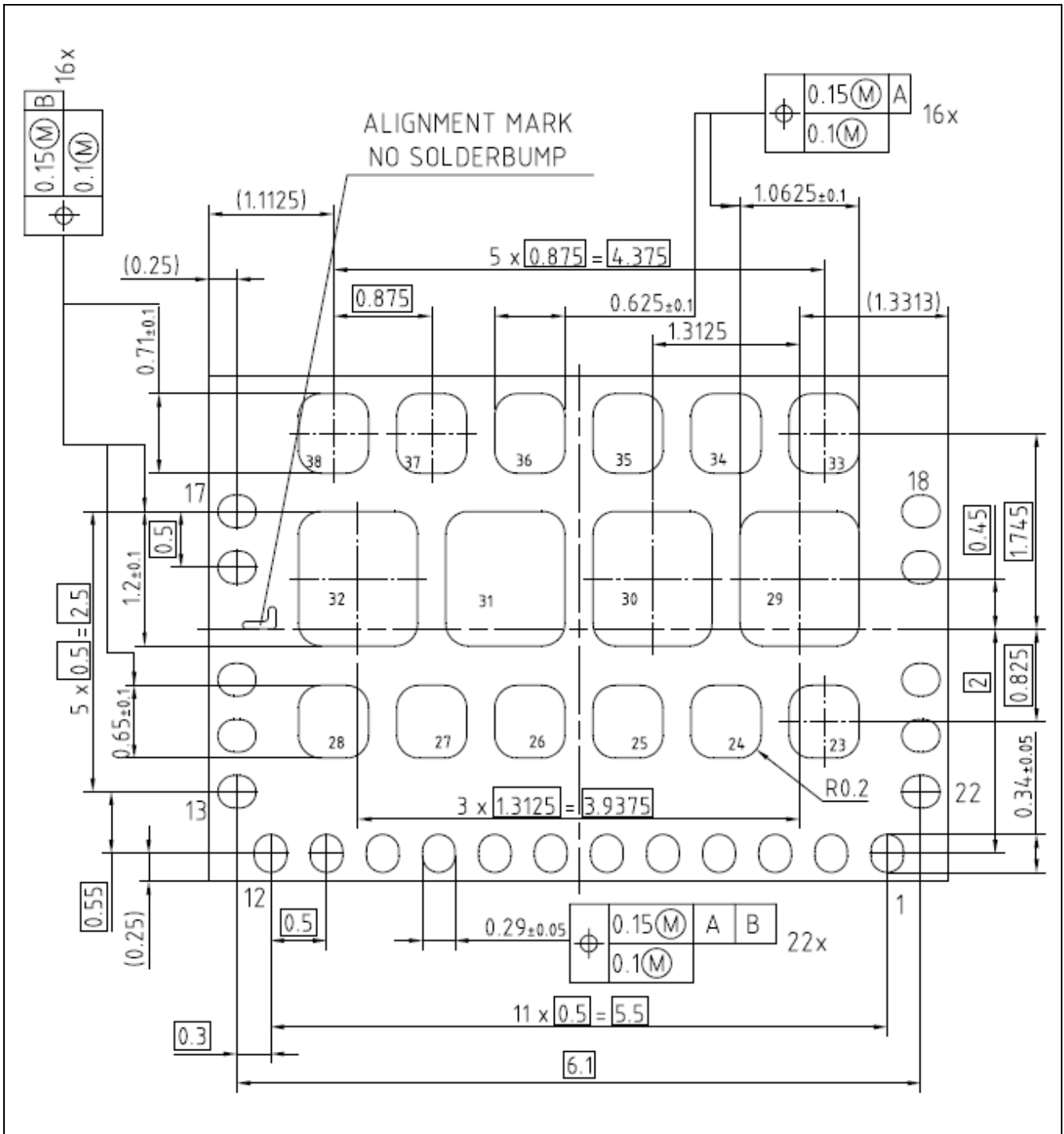

Figure 19 Mechanical Dimensions of Package (Bottom View) in mm

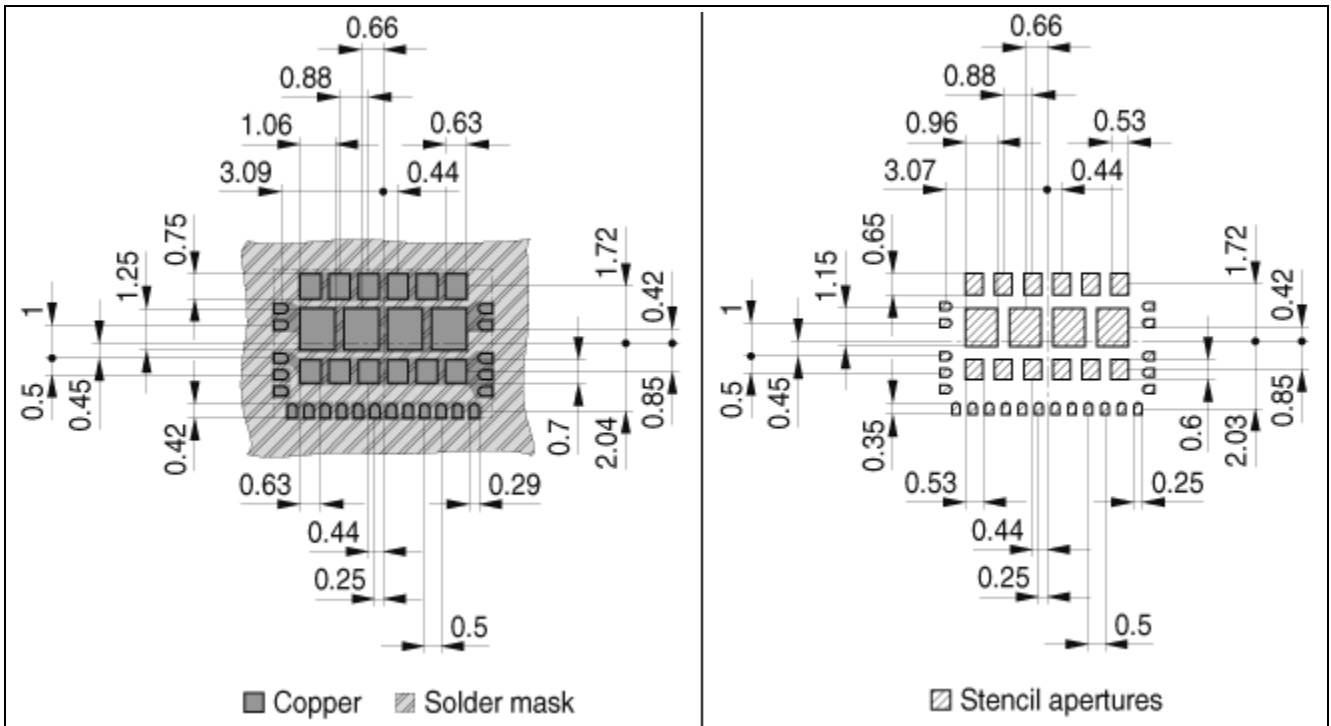

Figure 20 Landing Pattern and Stencil Dimensions (SW on upper end) in mm

10 Packaging Information

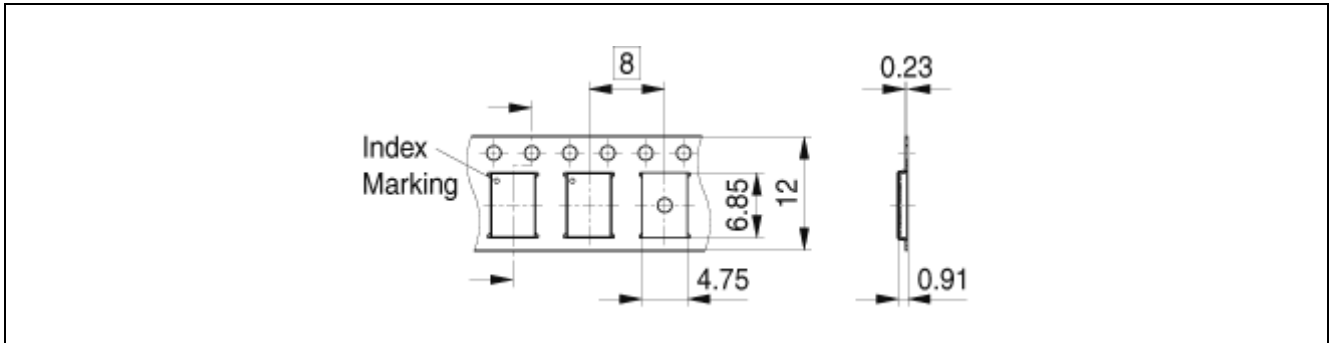

Figure 21 Packaging Information in mm

11 Board Layout Recommendations

The PCB (printed circuit board) layout design follows the listed industry standards:

- Recommended vias: 10 mil⁸ hole with 20 mil via pad diameter, 12 mil hole with 24 mil via pad diameter
- Minimum (typical) via to via center distance: 25 mil (30 ... 35 mil)
- Minimum feature width: 5 mil
- Minimum (typical) clearance: 5 mil (15 ... 20 mil)

Commonly, 10 mil via drill diameters are used for PCBs up to 150 mil thicknesses (usually 22 layers). For thicker boards, 12 mil vias are recommended. To reduce voltage spikes caused by parasitic circuit inductance, all primary decoupling capacitors for VIN, VDRV, BOOT and VCIN should be of MLCC type, X6S or X7R rated and located at the same board side as the powerstage close to their respective pins. This is especially important for the VIN to PGND MLCCs.

Electrical and thermal connection of the powerstage to the PCB is crucial for achieving high efficiency. Therefore, vias in VIN and PGND pads are required in the pad areas to connect most effectively to other power and PGND layers. Bigger value MLCC input capacitors should be placed at the bottom side of the PCB close to the vias of the powerstage's VIN and PGND pads. To reduce the stray inductance in the current commutation loop it is strongly recommended to have the 2nd layers from the top and the bottom of the board to be monolithic ground planes. All logic and signal connections between powerstage and controller should be embedded between two ground layers. The routing of the current sense lines back to the controller has to be done differentially, for example with 5 mil spacing and 10 – 15 mil distances to other potentials. If the PCB features more than 10 layers, the passive components associated with the current sense lines should be located only at the top side of the board. All resistors and capacitors near the powerstage should be in 0402 case size. For minimizing distribution loss to the load and maintaining signal integrity, have multiple layers/planes in parallel and ensure that the copper cross section for PGND is at least as big as it is for Vout.

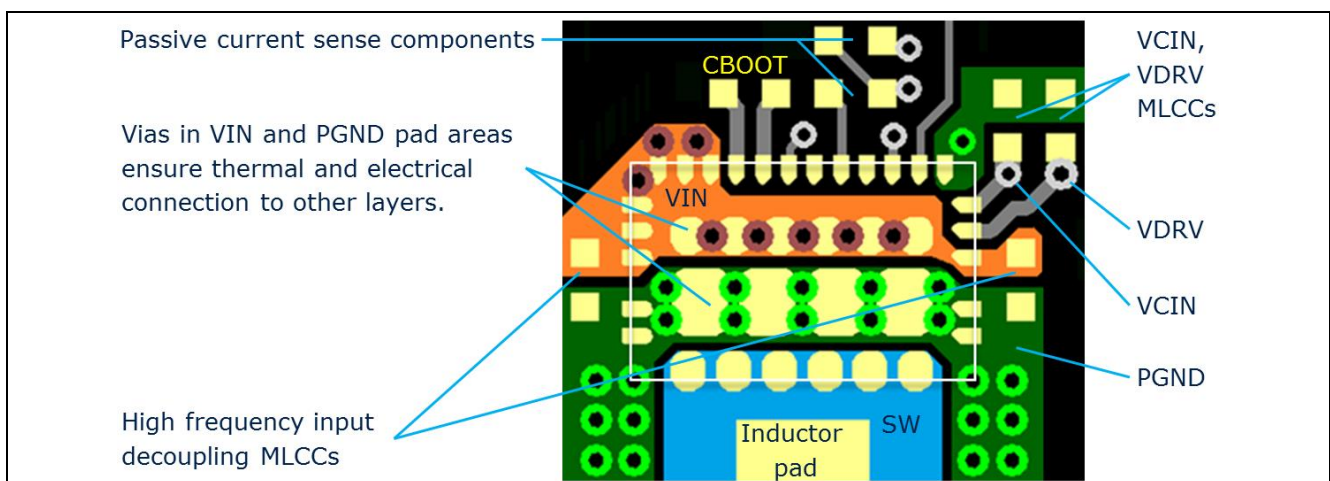

Figure 22 Generic Board Design

⁸ Unit conversion: 1 mil = 25.4 μm

www.infineon.com

Published by Infineon Technologies AG

X-ON Electronics

Largest Supplier of Electrical and Electronic Components

Click to view similar products for [Switching Voltage Regulators](#) category:

Click to view products by [Infineon](#) manufacturer:

Other Similar products are found below :

[FAN53610AUC33X](#) [FAN53611AUC123X](#) [FAN48610BUC33X](#) [FAN48610BUC45X](#) [FAN48617UC50X](#) [R3](#) [430464BB](#) [KE177614](#)
[MAX809TTR](#) [NCV891234MW50R2G](#) [NCP81103MNTXG](#) [NCP81203PMNTXG](#) [NCP81208MNTXG](#) [NCP81109GMNTXG](#)
[SCY1751FCCT1G](#) [NCP81109JMNTXG](#) [AP3409ADNTR-G1](#) [LTM8064IY](#) [LT8315EFE#TRPBF](#) [NCV1077CSTBT3G](#) [XCL207A123CR-G](#)
[MPM54304GMN-0002](#) [MPM54304GMN-0003](#) [XDPE132G5CG000XUMA1](#) [DA9121-B0V76](#) [LTC3644IY#PBF](#) [MP8757GL-P](#)
[MIC23356YFT-TR](#) [LD8116CGL](#) [HG2269M/TR](#) [OB2269](#) [XD3526](#) [U6215A](#) [U6215B](#) [U6620S](#) [LTC3803ES6#TR](#) [LTC3803ES6#TRM](#)
[LTC3412IFE](#) [LT1425IS](#) [MAX25203BATJA/VY+](#) [MAX77874CEWM+](#) [XC9236D08CER-G](#) [ISL95338IRTZ](#) [MP3416GJ-P](#) [BD9S201NUX-](#)
[CE2](#) [MP5461GC-Z](#) [MPQ4415AGQB-Z](#) [MPQ4590GS-Z](#) [MCP1642B-18IMC](#) [MCP1642D-ADJIMC](#)