

TLD1114-1EP

LITIX™ Basic+



Features

- Single channel device with integrated and protected output stage (current source), optimized to drive LEDs as additional low cost current source
- Easy direct control without external component from other LITIX Basic+ LED Drivers
- High output current (up to 360 mA)
- Possibility to off-load power consumption to allow maximum current driving capability via low cost external components (Power Shift)
- Very low current consumption in sleep mode
- Very low output leakage when channel is “off”
- Low current consumption during fault
- Output currents’ control via external low power resistor
- Easy delivery of additional current/power demand via other LITIX™ Basic+ family members with direct drive
- Reverse polarity protection allows reduction of external components and improves system performance at low battery/input voltages
- Overload protection
- Wide temperature range: $-40^{\circ}\text{C} < T_j < 150^{\circ}\text{C}$
- Output current control via external low power resistor
- Green product (RoHS compliant)

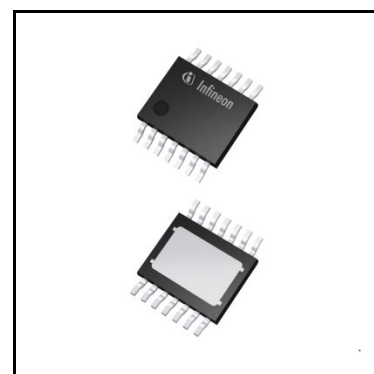

Potential applications

- Cost effective “stop”/ “tail” function implementation with shared and separated LEDs per function
- Turn indicators
- Position, fog, rear lights and side markers
- Animated light functions like wiping indicators and “welcome/goodbye” functions
- Day Running Light
- Interior lighting functions like ambient lighting (including RGB color control), illumination and dash board lighting
- LED indicators for industrial applications and instrumentation

Product validation

Qualified for Automotive Applications. Product Validation according to AEC-Q100/101.

Description

The LITIX™ Basic+ TLD1114-1EP is a single channel high-side driver IC with integrated output stage. It is designed to control LEDs with a current up to 360 mA. In typical automotive applications the device is capable of driving 3 red LEDs with a current up to 180 mA and even above, if not limited by the overall system thermal properties. Practically, the output current is controlled by an external resistor or reference source, independently from load and supply voltage changes.

Table 1 Product summary

Parameter	Symbol	Values
Operating voltage	$V_{S(nom)}$	5.5 V ... 40 V
Maximum voltage	$V_{S(max)}$ $V_{OUT(max)}$	40 V
Nominal output (load) current	$I_{OUT(nom)}$	180 mA (nominal) when using the automotive supply voltage range 8 V - 18 V. Currents up to $I_{OUT(max)}$ are possible with low thermal resistance R_{thJA}
Maximum output (load) current	$I_{OUT(max)}$	360 mA depending on R_{thJA}
Current accuracy at $R_{SET} = 10\text{ k}\Omega$	K_{RT}	900±3.33%
Current consumption in sleep mode	$I_{S(sleep, typ)}$	0.1 μ A
Maximum current consumption during fault	$I_{S(fault, ERRN)}$	850 μ A or less when fault is detected from another device (disabled via ERRN)

Type	Package	Marking
TLD1114-1EP	PG-TSDSO-14	TLD1114

Table of Contents

1	Block diagram	4
2	Pin configuration	5
2.1	Pin assignment	5
2.2	Pin definitions and functions	5
3	General product characteristics	7
3.1	Absolute maximum ratings	7
3.2	Functional range	8
3.3	Thermal resistance	9
4	Internal supply	10
4.1	Description	10
4.2	Electrical characteristics internal supply and EN pin	11
5	Power stage	13
5.1	Programmable output current accuracy	13
5.2	Power shift feature	14
5.2.1	Power shift via external MOSFET control and power resistors	15
5.2.2	Power shift components calculation	15
5.3	Protection	16
5.3.1	Thermal protection	16
5.3.2	Reverse battery protection	16
5.4	Output configuration via IN_SET, OUT_SET and PWMI pins	17
5.4.1	IN_SET pin	17
5.4.2	Output current adjustment via R_{SET}	17
5.4.3	Output control via IN_SET	17
5.4.4	IN_SET pin behavior during device overload management	19
5.4.5	OUT_SET pin	19
5.4.6	Direct control of PWMI	20
5.4.7	Timing diagrams	20
5.5	Electrical characteristics power stage	22
5.6	Electrical characteristics IN_SET, OUT_SET, PWR_SHS, PWM_SHG and PWMI pins for output settings 26	
6	Overload diagnosis	28
6.1	Error management via ERRN	28
6.1.1	ERRN pin	28
6.2	Fault management	29
6.3	Electrical characteristics: Overload management	30
7	Application information	32
8	Package outline	33
9	Revision History	34

Block diagram

1 Block diagram

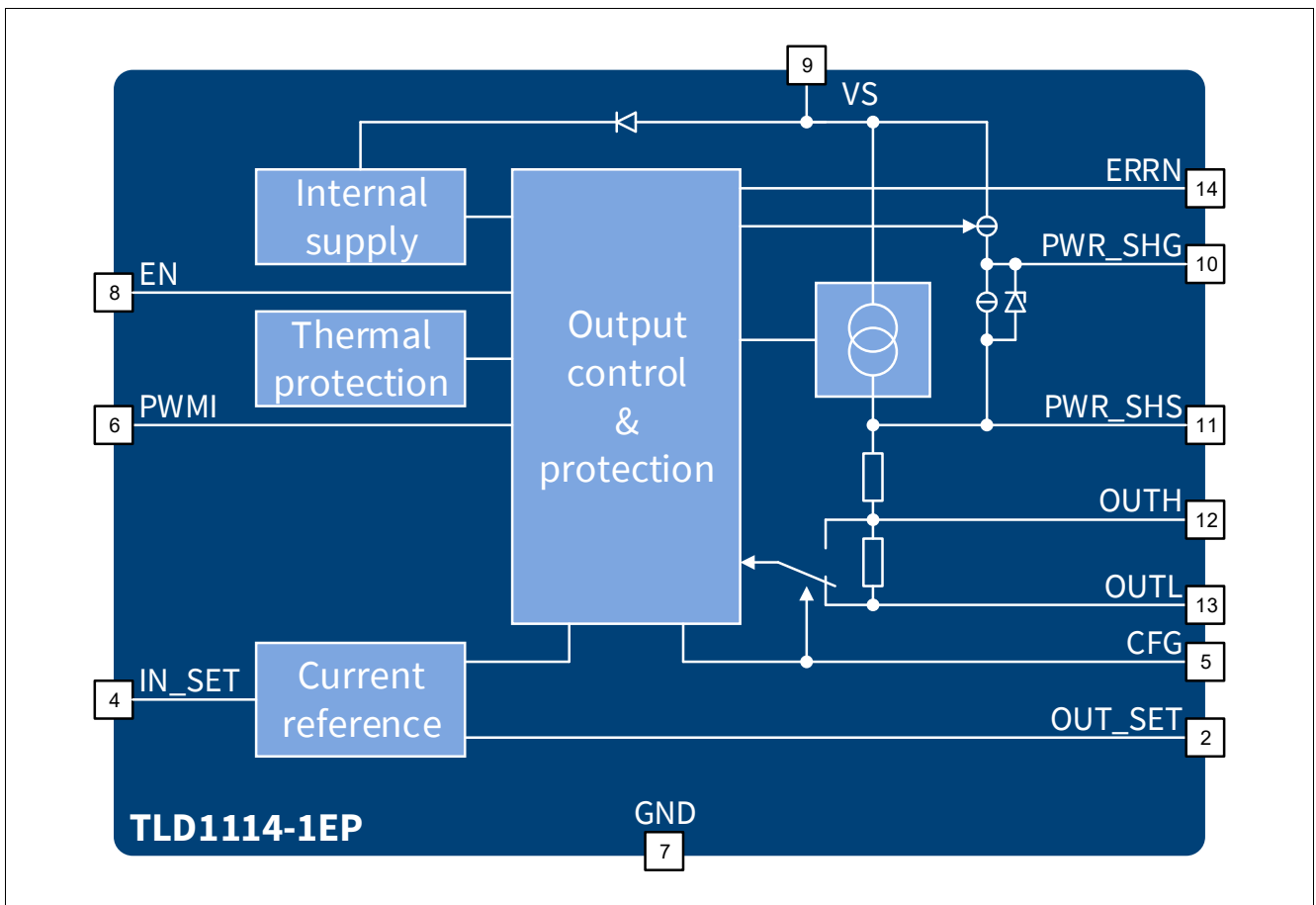

Figure 1 Block diagram

Pin configuration

2 Pin configuration

2.1 Pin assignment

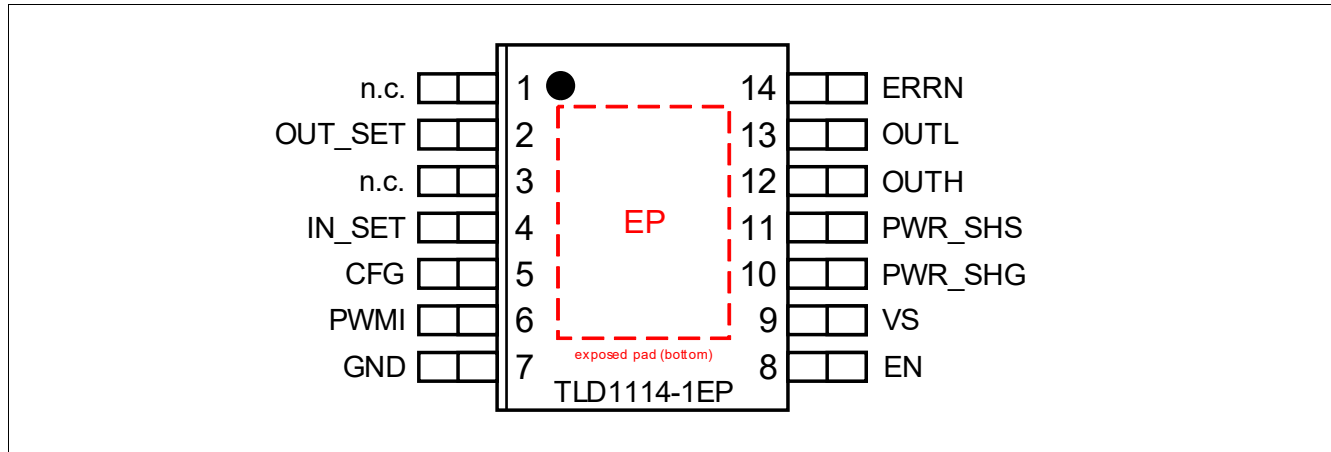

Figure 2 Pin configuration

2.2 Pin definitions and functions

Pin	Symbol	Function
9	VS	Supply voltage; Connected to battery or supply control switch, with EMC filter
7	GND	Ground; Signal ground
4	IN_SET	Control input for OUT channel; Connect to a low power resistor to adjust OUT output current. Alternatively, a different current reference (i.e. the OUT_SET of another LITIX™ Basic+ LED Driver) may be connected
2	OUT_SET	Control output for additional current source; If an additional channel or output current with same input control is needed, connect this pin to the IN_SET pin of the additional LED driver. If not used, leave the pin open
5	CFG	Configuration input for OUT current accuracy; If higher current accuracy is required to drive the target load, leave this pin open, else connect it to GND (see Chapter 5 for further details)
6	PWMI	PWM input; Connect to an external PWM controller. If not used, connect to GND
14	ERRN	ERROR flag I/O; Open drain, active low. Connect to a pull-up resistor
8	EN	Output enable control input; Connect to a control input or VS via a resistor divider or Zener diode
12	OUTH	Channel output; Connect to the target load when low V_{PS} drop at higher output current is required, otherwise leave the pin open
13	OUTL	Channel output; Connect to the target load when high resolution at lower output current is required, otherwise leave the pin open

Pin configuration

Pin	Symbol	Function
11	PWR_SHS	Power shift source control output; Connect to a power resistor or to the source of an external NMOS to allow power shift control. If not used, leave the pin open
10	PWR_SHG	Power shift gate control output; Connect to the gate of an external NMOS to allow power shift control. If not used, leave the pin open
1, 3	n.c.	Not connected; Leave these pins open
Exposed Pad	EP	Exposed Pad; Connected to GND-pin in application

General product characteristics

3 General product characteristics

3.1 Absolute maximum ratings

Table 2 Absolute maximum ratings¹⁾

$T_J = -40^\circ\text{C}$ to $+150^\circ\text{C}$; $R_{IN_SET} = 10\text{ k}\Omega$; all voltages with respect to GND, positive current flowing into input and I/O pins, positive current flowing out from output pins (unless otherwise specified)

Parameter	Symbol	Values			Unit	Note or Test Condition	Number
		Min.	Typ.	Max.			
Voltage							
Supply voltage	V_S	-18	–	40	V	–	P_4.1.1
EN voltage	V_{EN}	-18	–	40	V	–	P_4.1.3
EN voltage related to V_S : $V_{EN} - V_S$	$V_{EN(VS)}$	-40	–	18	V	–	P_4.1.4
EN voltage related to V_{OUT} : $V_{EN} - V_{OUT}$	$V_{EN(VOUT)}$	-18	–	40	V	–	P_4.1.5
PWR_SHG voltage	V_{PWR_SHG}	-1	–	40	V	–	P_4.1.6
PWR_SHS voltage related to V_{OUTH} : $V_{PWR_SHS} - V_{OUTH}$	$V_{PWR_SHS(OUTH)}$	-0.4	–	0.4	V	–	P_4.1.7
PWR_SHS voltage related to V_{OUTL} : $V_{PWR_SHS} - V_{OUTL}$	$V_{PWR_SHS(OUTL)}$	-0.8	–	0.8	V	–	P_4.1.46
PWR_SHS voltage	V_{PWR_SHIFTS}	-1	–	40	V	–	P_4.1.8
PWR_SHG voltage related to PWR_SHS: $V_{PWR_SHIFTS} - V_{PWR_SHS}$	$V_{PWR_SHIFT(GS)}$	-0.3	–	6	V	–	P_4.1.9
Output voltage	$V_{OUTL/H}$	-1	–	40	V	–	P_4.1.10
Output voltage related to V_S : $V_S - V_{OUT}$	$V_{OUT(VS)}$	-18	–	40	V	–	P_4.1.11
IN_SET voltage	V_{IN_SET}	-0.3	–	6	V	–	P_4.1.12
OUT_SET voltage	V_{OUT_SET}	-0.3	–	6	V	–	P_4.1.13
CFG voltage	V_{CFG}	-0.3	–	6	V	–	P_4.1.20
PWMI voltage	V_{PWMI}	-0.3	–	6	V	–	P_4.1.14
ERRN voltage	V_{ERRN}	-0.3	–	40	V	–	P_4.1.18
Current							
Output current	I_{OUTH}	0	–	370	mA	–	P_4.1.22
Output current	I_{OUTL}	0	–	200	mA	–	P_4.1.41
PWMI current	I_{PWMI}	-0.5	–	0.5	mA	–	P_4.1.26
IN_SET current	I_{IN_SET}	0	–	800	μA	–	P_4.1.48
OUT_SET current	I_{OUT_SET}	0	–	0.5	mA	–	P_4.1.32
Temperature							
Junction temperature	T_J	-40	–	150	$^\circ\text{C}$	–	P_4.1.33

General product characteristics

Table 2 Absolute maximum ratings¹⁾ (cont'd)

$T_J = -40^\circ\text{C}$ to $+150^\circ\text{C}$; $R_{IN_SET} = 10\text{ k}\Omega$; all voltages with respect to GND, positive current flowing into input and I/O pins, positive current flowing out from output pins (unless otherwise specified)

Parameter	Symbol	Values			Unit	Note or Test Condition	Number
		Min.	Typ.	Max.			
Storage temperature	T_{stg}	-55	–	150	°C	–	P_4.1.34

ESD susceptibility

ESD susceptibility all pins to GND	V_{ESD}	-2	–	2	kV	HBM ²⁾	P_4.1.36
ESD susceptibility all pins to GND	V_{ESD}	-500	–	500	V	CDM ³⁾	P_4.1.37
ESD susceptibility Pin 1, 7, 8, 14 (corner pins) to GND	$V_{ESD1,7,8,14}$	-750	–	750	V	CDM ³⁾	P_4.1.38

1) Not subject to production test, specified by design

2) ESD susceptibility, HBM according to ANSI/ESDA/JEDEC JS001 (1.5k Ω , 100 pF)

3) ESD susceptibility, Charged Device Model “CDM” according JEDEC JESD22-C101

Notes

1. Stresses above the ones listed here may cause permanent damage to the device. Exposure to absolute maximum rating conditions for extended periods may affect device reliability.
2. Integrated protection functions are designed to prevent IC destruction under fault conditions described in the data sheet. Fault conditions are considered as “outside” normal operating range. Protection functions are not designed for continuous repetitive operation.

3.2 Functional range

Table 3 Functional range

Parameter	Symbol	Values			Unit	Note or Test Condition	Number
		Min.	Typ.	Max.			
Voltage range for normal operation	$V_{S(nom)}$	5.5	–	18	V	–	P_4.2.1
Extended supply voltage for functional range	$V_{S(ext)}$	$V_{SUV(ON)}$	–	40	V	–	P_4.2.2
Junction temperature	T_J	-40	–	150	°C	–	P_4.2.4

Note: Within the Normal Operation range, the IC operates as described in the circuit description. Within the Extended Operation range, parameters deviations are possible. The electrical characteristics are specified within the conditions given in the Electrical Characteristics table.

General product characteristics

3.3 Thermal resistance

Note: This thermal data was generated in accordance with JEDEC JESD51 standards. For more information, go to www.jedec.org.

Table 4 Thermal resistance¹⁾

Parameter	Symbol	Values			Unit	Note or Test Condition	Number
		Min.	Typ.	Max.			
Junction to Case	R_{thJC}	–	–	10	K/W	¹⁾²⁾	P_4.3.1
Junction to Ambient 1s0p board	R_{thJA1}	–	61 56	–	K/W	¹⁾³⁾ $T_A = 85^\circ\text{C}$ $T_A = 135^\circ\text{C}$	P_4.3.3
Junction to Ambient 2s2p board	R_{thJA2}	–	45 43	–	K/W	¹⁾⁴⁾ $T_A = 85^\circ\text{C}$ $T_A = 135^\circ\text{C}$	P_4.3.4

- 1) Not subject to production test, specified by design.
- 2) Specified R_{thJC} value is simulated at natural convection on a cold plate setup (all pins and exposed pad are fixed to ambient temperature). $T_A = 85^\circ\text{C}$. Total power dissipation = 1.5 W
- 3) Specified R_{thJA} value is according to Jedec JESD51-3 at natural convection on FR4 1s0p board. The product (chip+package) was simulated on a $76.2 \times 114.3 \times 1.5$ mm board with $70 \mu\text{m}$ Cu, 300 mm^2 cooling area. Total power dissipation 1.5W distributed statically and homogenously over all power stages
- 4) Specified R_{thJA} value is according to Jedec JESD51-5,-7 at natural convection on FR4 2s2p board; The product (chip+package) was simulated on a $76.2 \times 114.3 \times 1.5$ mm board with 2 inner copper layers (2×70 mm Cu, 2×35 mm Cu). Where applicable a thermal via array under the exposed pad contacted the first inner copper layer. Total power dissipation 1.5W distributed statically and homogenously over all power stages

Internal supply

4 Internal supply

This chapter describes the internal supply in its main parameters and functionality.

4.1 Description

The internal supply principle is highlighted in the concept diagram of [Figure 3](#).

If the voltage applied at the EN pin is below $V_{EN(th)}$ the device enters sleep mode. In this state all internal functions are switched off and the current consumption is reduced to $I_{S(sleep)}$.

As soon as the voltage applied at the supply pin V_S is above $V_{SUV(ON)}$ and the voltage applied at the EN pin is above $V_{EN(th)}$, after the power-on reset time t_{POR} , the device is ready to deliver output current from the output stage. The power on reset time t_{POR} has to be taken into account also in relevant application conditions, i. e. with PWM control from V_S or EN lines.

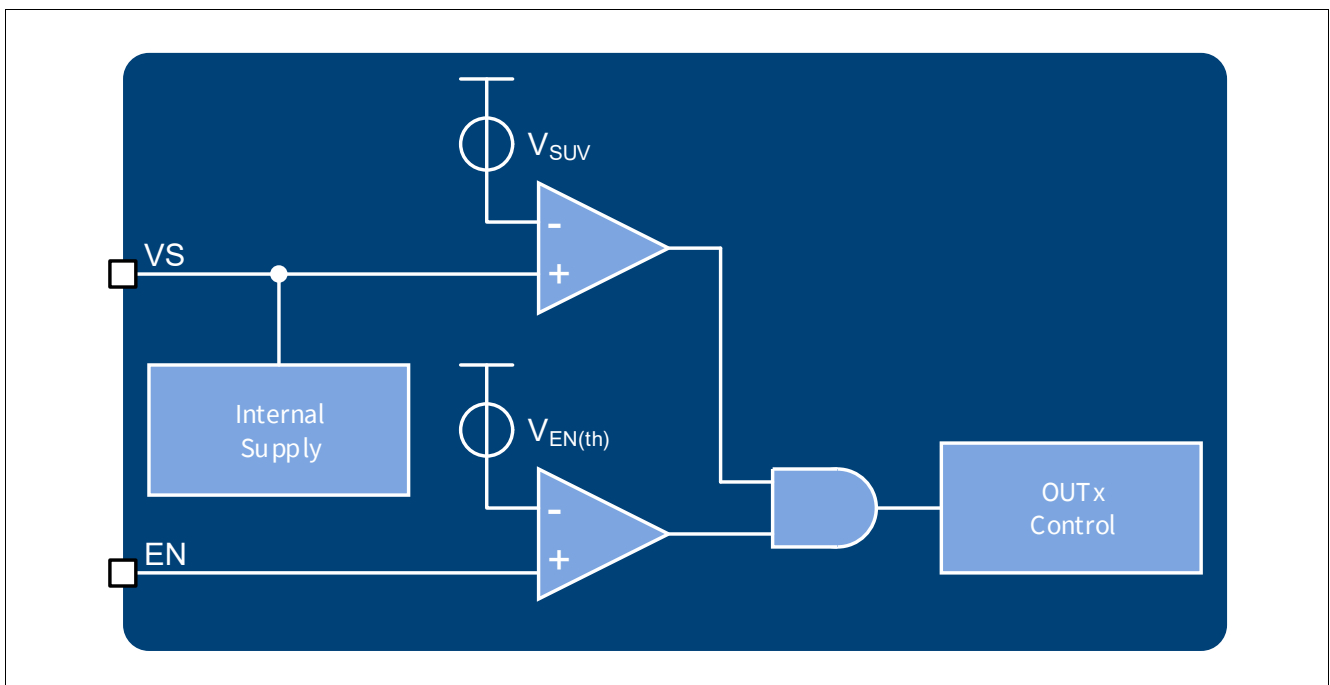

Figure 3 Internal supply

Furthermore, as soon as the voltage applied at the supply pin V_S is above $V_{SUV(ON)}$ and the voltage applied to the EN pin V_{EN} is above $V_{EN(th)}$, the device is ready to detect and report overtemperature condition via ERRN (error network pin) as described in [Chapter 6](#).

To program output enable via EN pin there are several possibilities, like a resistor divider from V_S to GND, a Zener diode from EN to V_S and also a logic control pin (e.g. from a microcontroller output).

Internal supply

4.2 Electrical characteristics internal supply and EN pin

Table 5 Electrical characteristics: Internal supply and EN pin

$T_J = -40^\circ\text{C}$ to $+150^\circ\text{C}$; $V_S = 5.5\text{ V}$ to 18 V ; $R_{IN_SET} = 10\text{ k}\Omega$; all voltages with respect to GND, positive current flowing into input and I/O pins, positive current flowing out from output pins (unless otherwise specified)

Parameter	Symbol	Values			Unit	Note or Test Condition	Number
		Min.	Typ.	Max.			
Current consumption, sleep mode	$I_{S(\text{sleep})}$	–	0.1	2	μA	¹⁾ $V_{EN} = 0\text{ V}$ $T_J < 85^\circ\text{C}$ $V_S = 18\text{ V}$ $V_{OUT} = 3.6\text{ V}$	P_5.2.1
Current consumption, active mode (no fault)	$I_{S(\text{active})}$	–	1.5	3	mA	$V_{EN} = 5.5\text{ V}$ $I_{IN_SET} = 0\ \mu\text{A}$ $T_J < 105^\circ\text{C}$ $V_S = 18\text{ V}$ $V_{OUT} = 3.6\text{ V}$	P_5.2.3
Current consumption during fault condition triggered from another device sharing ERRN bus	$I_{S(\text{fault, ERRN})}$	–	–	850	μA	$V_{EN} = 5.5\text{ V}$ $T_J < 105^\circ\text{C}$ $V_S = 18\text{ V}$ $V_{ERRN} = 0\text{ V}$ $V_{OUT} = 3.6\text{ V}$	P_5.2.4

Supply thresholds

Required supply voltage for output activation	$V_{SUV(\text{ON})}$	–	–	5.5	V	$V_{EN} = V_S$ $V_{OUT} = 3\text{ V}$ $R_{IN_SET} = 6.8\text{ k}\Omega$ $I_{OUT} > 50\% I_{OUT(\text{nom})}$	P_5.2.5
Required supply voltage for output deactivation	$V_{SUV(\text{OFF})}$	4.5	–	–	V	$V_{EN} = V_S$ $V_{OUT} = 3\text{ V}$ $R_{IN_SET} = 6.8\text{ k}\Omega$ $I_{OUT} < 50\% I_{OUT(\text{nom})}$	P_5.2.6
Supply voltage activation hysteresis: $V_{SUV(\text{ON})} - V_{SUV(\text{OFF})}$	$V_{SUV(\text{hys})}$	–	200	–	mV	¹⁾ $V_{EN} > V_{EN(\text{th})}$	P_5.2.8
EN output enable threshold	$V_{EN(\text{th})}$	1.4	1.65	1.8	V	$V_S = 5.5\text{ V}$ $V_{PS} = 2\text{ V}$ $R_{IN_SET} = 6.8\text{ k}\Omega$ $I_{OUT} = 50\% I_{OUT(\text{nom})}$	P_5.2.9
EN pull-down current	$I_{EN(\text{PD})}$	–	–	60	μA	¹⁾ $V_S > 8\text{ V}$ $V_{EN} = 2.8\text{ V}$	P_5.2.17
EN pull-down current	$I_{EN(\text{PD})}$	–	–	110	μA	¹⁾ $V_S > 8\text{ V}$ $V_{EN} = 5.5\text{ V}$	P_5.2.14
EN pull-down current	$I_{EN(\text{PD})}$	–	–	350	μA	¹⁾ $V_S > 8\text{ V}$ $V_{EN} = V_S$	P_5.2.15

Internal supply

Table 5 Electrical characteristics: Internal supply and EN pin (cont'd)

$T_J = -40^\circ\text{C}$ to $+150^\circ\text{C}$; $V_S = 5.5\text{ V}$ to 18 V ; $R_{\text{IN_SET}} = 10\text{ k}\Omega$; all voltages with respect to GND, positive current flowing into input and I/O pins, positive current flowing out from output pins (unless otherwise specified)

Parameter	Symbol	Values			Unit	Note or Test Condition	Number
		Min.	Typ.	Max.			
Timing							
Power on reset delay time	t_{POR}	–	–	25	μs	¹⁾ V_S rising from 0 V to 13.5 V $V_{\text{OUT}} = 3.6\text{ V}$ $R_{\text{IN_SET}} = 6.8\text{ k}\Omega$ $I_{\text{OUT}} = 80\% I_{\text{OUT(nom)}}$	P_5.2.13

1) Not subjected to production test: specified by design.

Power stage

5 Power stage

The output stage is realized as high-side current source with an output current up to 360mA. During off state the leakage current at the output stage is minimized in order to prevent a slightly glowing LED.

The maximum output current is limited by the power dissipation and used PCB cooling areas.

For an operating output current control loop, the supply and output voltage have to be considered according to the following parameters:

- Required supply voltage for current control $V_{S(CC)}$
- Voltage drop over through the output stage during current control $V_{PS(CC)}$
- Required output voltage for current control $V_{OUT(CC)}$

5.1 Programmable output current accuracy

In many rear light functions, a significant cost reduction is achieved increasing the number of LEDs per OUT (typically in series of three): this system implementation implies the need for low output voltage drop at low battery operative range, together with very high output current accuracy. As high output current accuracy needs an internal shunt voltage drop measurement in series to the output stage (the highest drop on the internal implies the highest accuracy), these two system requirements often result in a trade-off where, within a certain maximum output voltage drop, only a reduced range of output current can achieve the desired accuracy.

To provide high accuracy at low output currents and low output voltage drop ($V_{PSH/L}$) at high currents, the TLD1114-1EP offers the capability to select alternative output accuracy settings via the CFG output configuration pin. In this way, choosing the proper connection of the output load between OUTH and OUTL, the highest current accuracy with low drop $V_{PSH/L}$ can be achieved. When CFG is connected to GND, the device provides low V_{PSH} drop and high accuracy for the highest current ranges, provided that OUTH pin is used as output. When CFG pin is left open and the load is connected to OUTL pin, the highest current accuracy is also provided in the lowest current range.

Table 6 shows the configuration options to achieve the best system targets. Further implementation details are shown in **Chapter 7**.

Table 6 Output current accuracy configuration overview¹⁾

CFG	OUTL	OUTH	Output current accuracy	Output voltage drop
Connected to GND	Open	Connected to load	4% or better for 160 mA < $I_{OUTH(typ)} < 360 \text{ mA}^{2)}$	$V_{PSH} < 650 \text{ mV}$ for 360 mA > $I_{OUTH} > 88\% I_{OUTH(typ)}^{3)}$
Open	Connected to load	Open	4% or better for 30 mA < $I_{OUTL(typ)} < 180 \text{ mA}^{2)}$	$V_{PSL} < 650 \text{ mV}$ for 180 mA > $I_{OUTL} > 88\% I_{OUTL(typ)}^{3)}$

1) The table shows the recommended application configuration. For detailed test conditions refer to electrical characteristics (**Table 7**)

2) $T_j = 25^\circ\text{C}$, refer to parameters P_6.5.3 and P_6.5.8.

3) $T_j = -40^\circ\text{C}$, refer to parameters P_6.5.49 and P_6.5.50.

Power stage

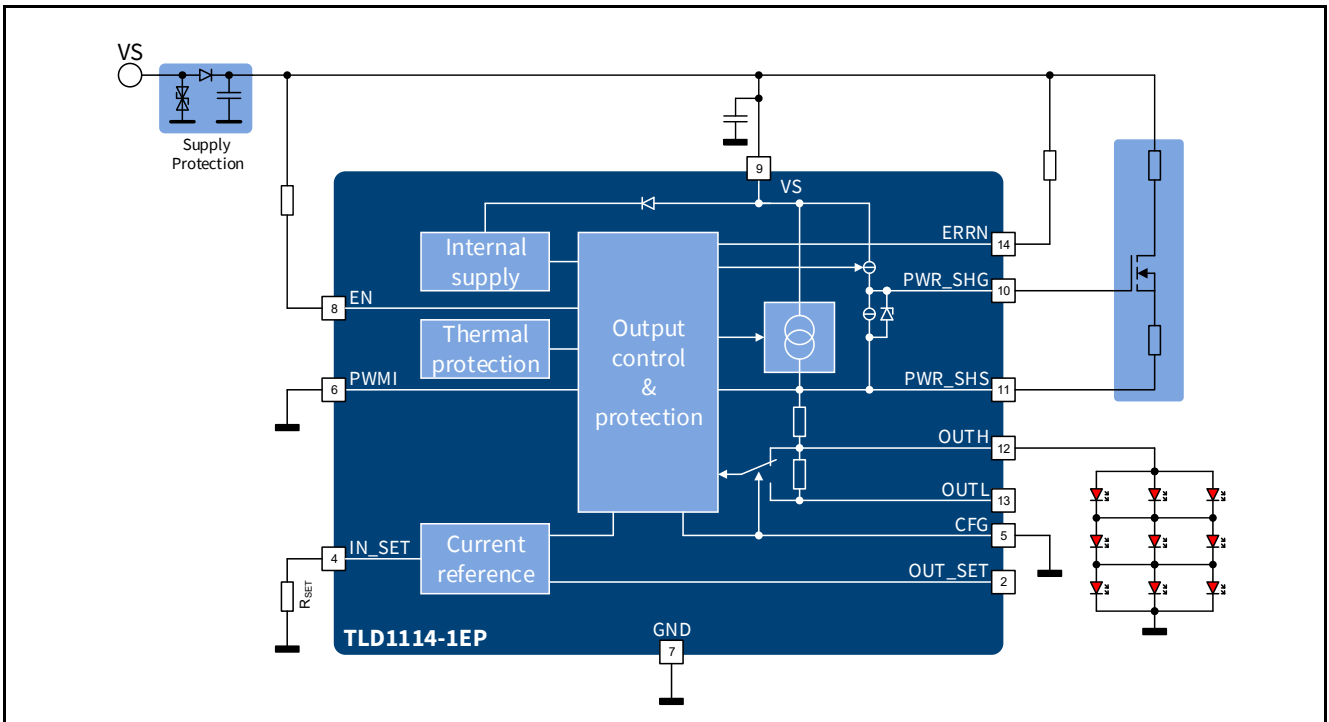

Figure 4 Configuration example with low V_{PS} drop at high current accuracy (CFG connected to GND)

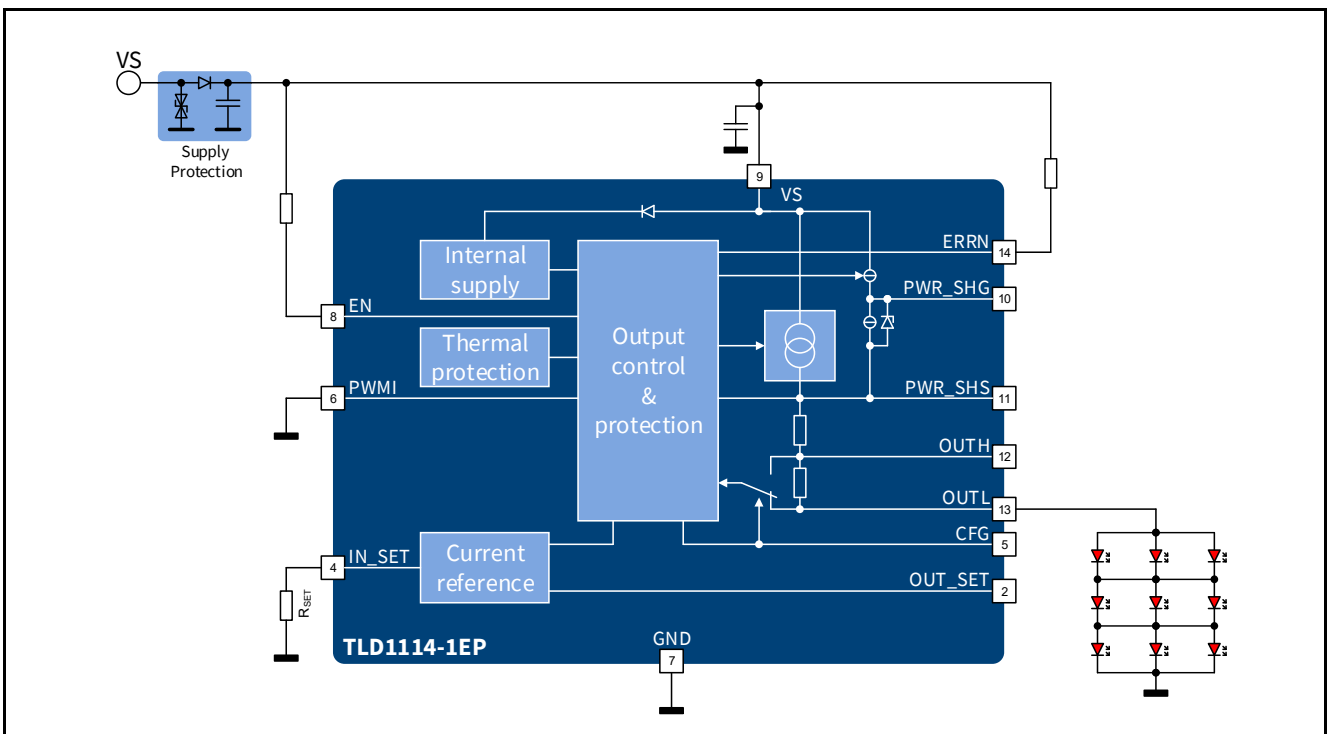

Figure 5 Configuration example with high accuracy at low current range (CFG open)

5.2 Power shift feature

Furthermore, the device provides the possibility of managing high power dissipation (higher than allowed by the thermal impedance R_{thJA} of the application) by controlling the current flow on a few external, low cost, discrete components.

Power stage

5.2.1 Power shift via external MOSFET control and power resistors

The control of power dissipation can be done via usage of PWR_SHG and PWR_SHS control pins: when V_{PS} output voltage drop exceeds the activation voltage threshold of an external switch, the voltage between PWR_SHG and PWR_SHS allows to turn it on (usually a low power external NMOS) and, in conjunction with the usage of limiting power resistors, routes most of the configured output current (in a percentage depending on external components values) outside the TLD1114-1EP. Figure 6 shows an embodiment example of the power shift feature.

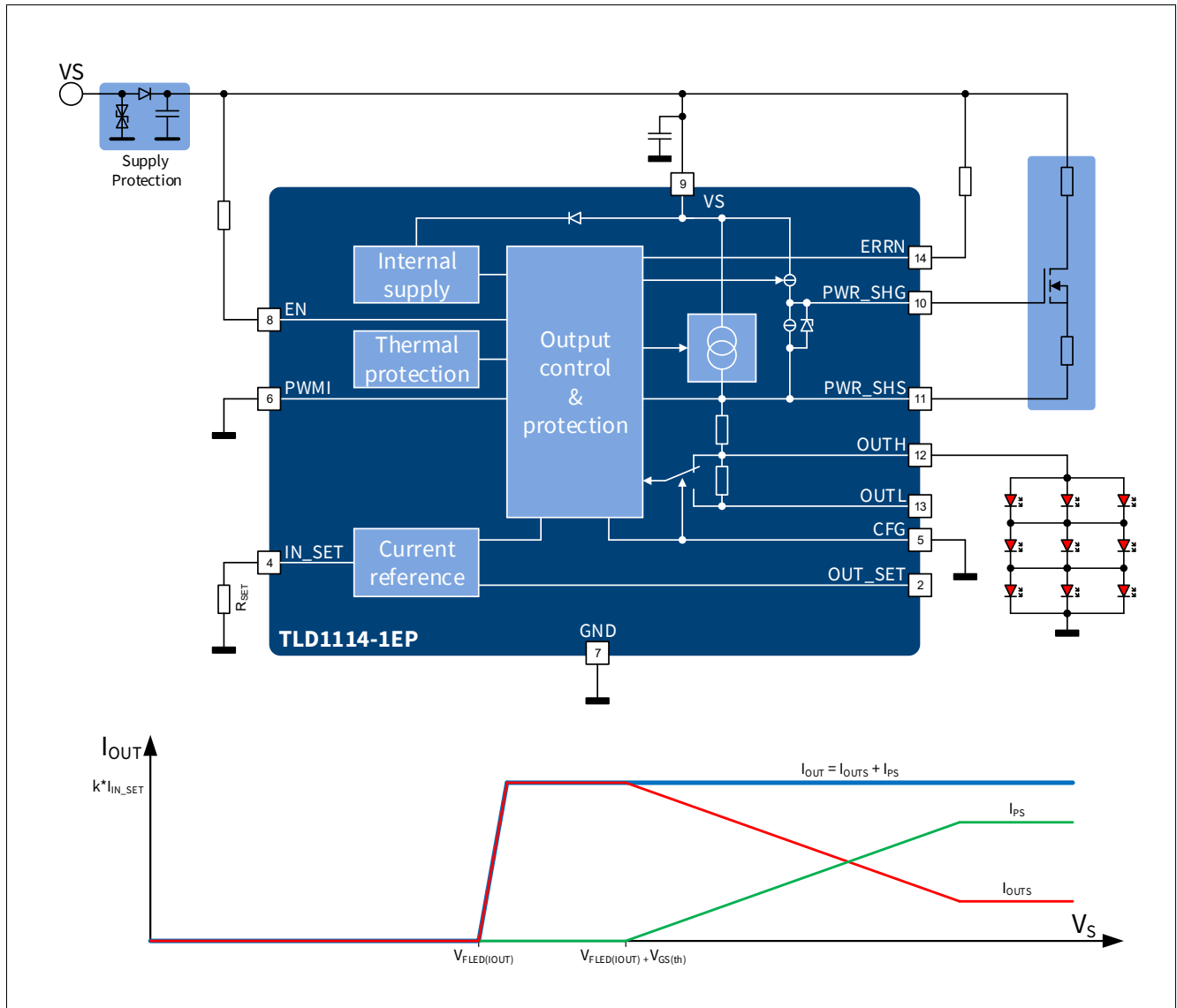

Figure 6 External MOSFET control concept

5.2.2 Power shift components calculation

Referring to the diagram example of Figure 6, in order to properly dimension the resistors values, the following parameters have to be considered:

- Minimum current $I_{OUT(int, min)}$ intended to flow through the TLD1114-1EP output stage at maximum operative supply voltage $V_{S(OP, max)}$
- Maximum current from power shift path $I_{OUT(int, max)}$ (e.g. through external NMOS and dissipation resistors) at maximum overvoltage battery stress $V_{S(OV, max)}$ in the application

Power stage

- External NMOS voltage threshold V_{GS}
- Forward voltage $V_{F(LED)}$ of the output LED load and forward voltage $V_{F(D)}$ of the reverse polarity diode D (when used).

For a safe drive of the external NMOS switch, when the OUT voltage drop V_{PS} reaches a voltage greater than $V_{GS(CL)}$, the PWR_SHG voltage is automatically limited (see P_6.6.16).

5.3 Protection

The device provides embedded protective functions, which are designed to prevent IC damage under fault conditions described in this datasheet. Fault conditions are considered as “outside” normal operating range. Protective functions are not designed for continuous nor for repetitive operations.

5.3.1 Thermal protection

A thermal protection circuitry is integrated in the device. It is realized by a temperature monitoring of the output stages.

As soon as the junction temperature exceeds the overtemperature threshold T_{JSD} the output current is disabled and the IN_SET pin goes in a weak pull-down state with a current consumption $I_{IN_SET(fault)}$. If the junction temperature cools down below $T_{JSD} - T_{J(hys)}$, the IN_SET pin rise again to $V_{IN_SET(ref)}$ (within an additional time $t_{IN_SET(del)}$) and consequently, the output current rise again (see [Chapter 6](#) for a detailed description of fault management).

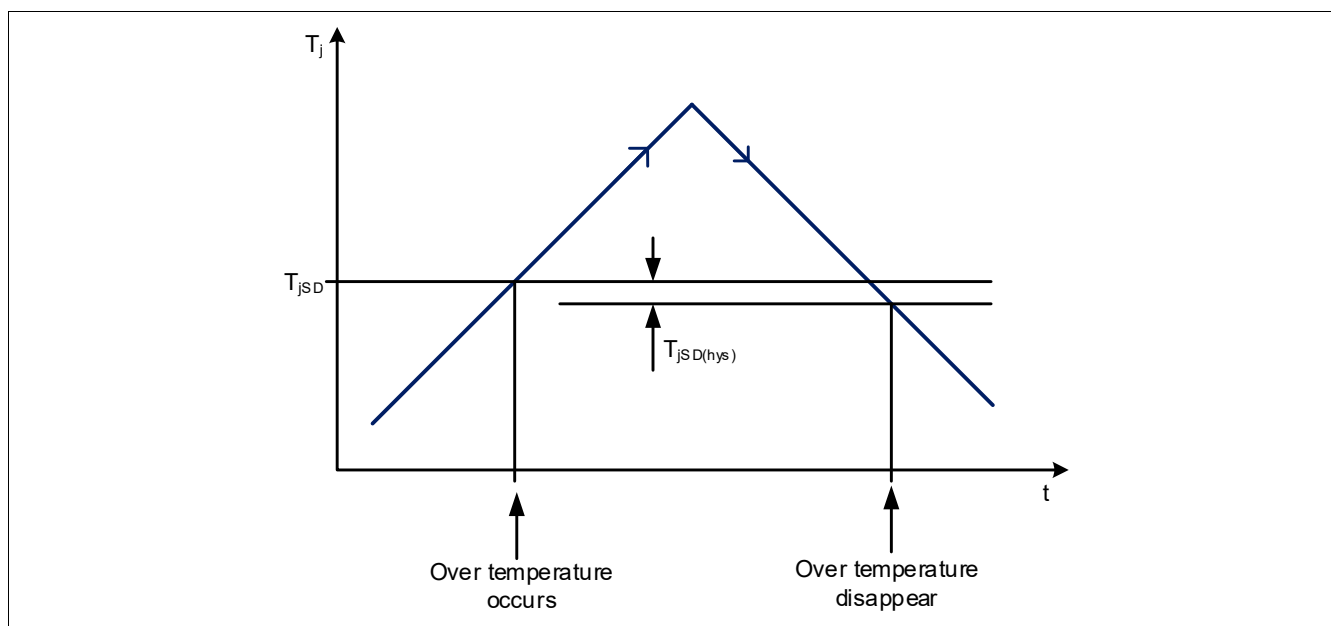

Figure 7 Overtemperature shut down auto-restart thresholds

As long as the device remains into overtemperature condition, ERRN pin remains low.

5.3.2 Reverse battery protection

The device has an integrated reverse battery protection feature. This feature protects the driver IC itself and, potentially, also connected LEDs. The output reverse current is limited to $I_{OUT(REV)}$ by the reverse battery protection.

Power stage

5.4 Output configuration via IN_SET, OUT_SET and PWMI pins

Outputs current can be defined via IN_SET and OUT_SET (to drive additional devices without further external components) pin.

5.4.1 IN_SET pin

The IN_SET pin is a multiple function pin for the output current definition and input control.

Output current definition and analog dimming control can be done defining accordingly the IN_SET current.

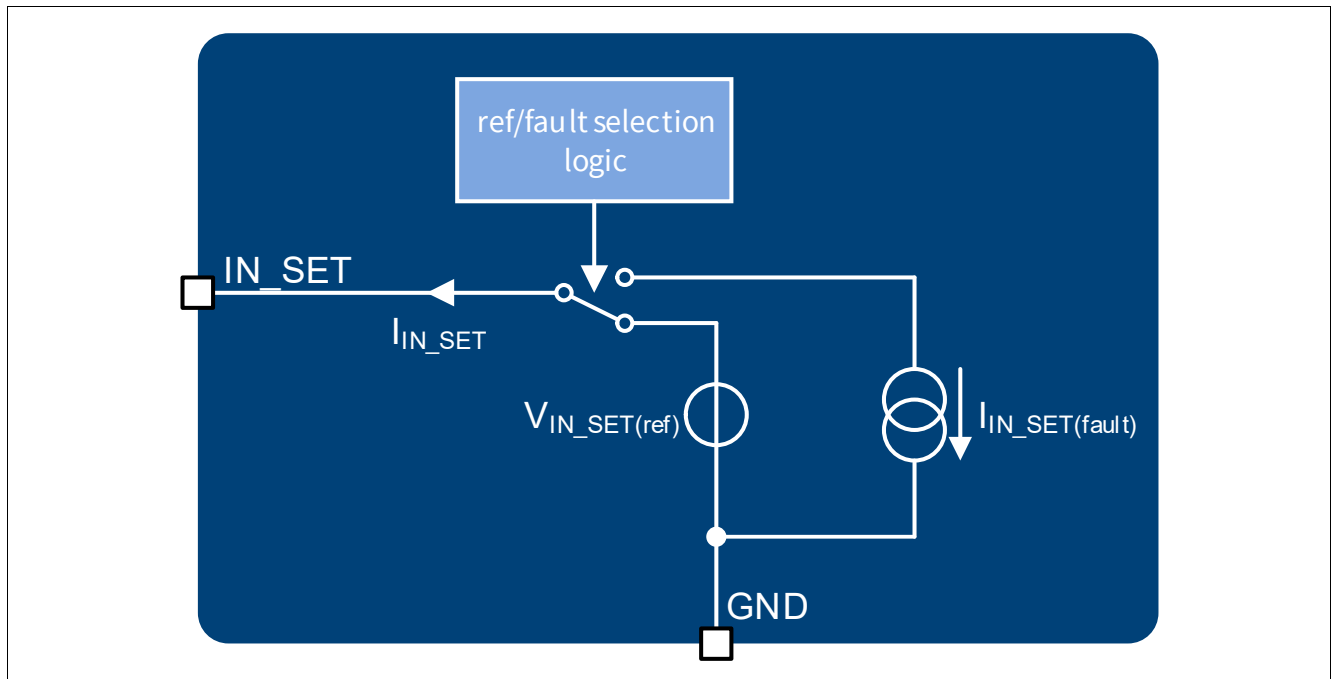

Figure 8 IN_SET pin block diagram

5.4.2 Output current adjustment via R_SET

The output current for the channel can be defined connecting a low power resistor (R_{SET}) between the IN_SET pin and GND. The dimensioning of the resistor can be done using the formula:

$$I_{OUT} = k \cdot I_{IN_SET} = k \cdot V_{IN_SET(ref)} / R_{SET} \quad (5.1)$$

The gain factor k (defined as the ratio I_{OUT}/I_{IN_SET}) is graphically described in [Figure 9](#).

The current through the R_{SET} is defined by the resistor itself and the reference voltage $V_{IN_SET(ref)}$, which is applied to the IN_SET pin when the device is supplied and the channel enabled.

5.4.3 Output control via IN_SET

The IN_SET pin can be connected via R_{SET} to the open-drain output of a microcontroller or to an external NMOS transistor as described in [Figure 11](#). This signal can be used to turn off the relative output stages of the IC.

A minimum IN_SET current of $I_{IN_SET(ACT)}$ is required to turn on the output stages. This feature is implemented to prevent glowing of LEDs caused by leakage currents on the IN_SET pin, see again [Figure 9](#) for details.

Power stage

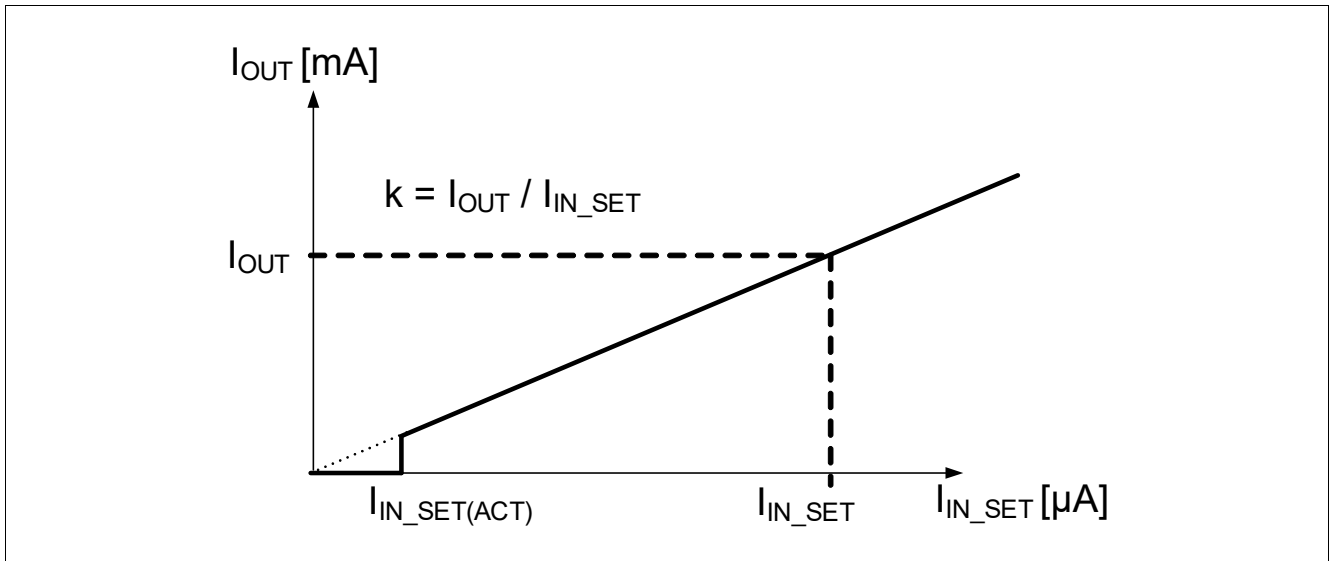

Figure 9 I_{OUT} vs I_{IN_SET}

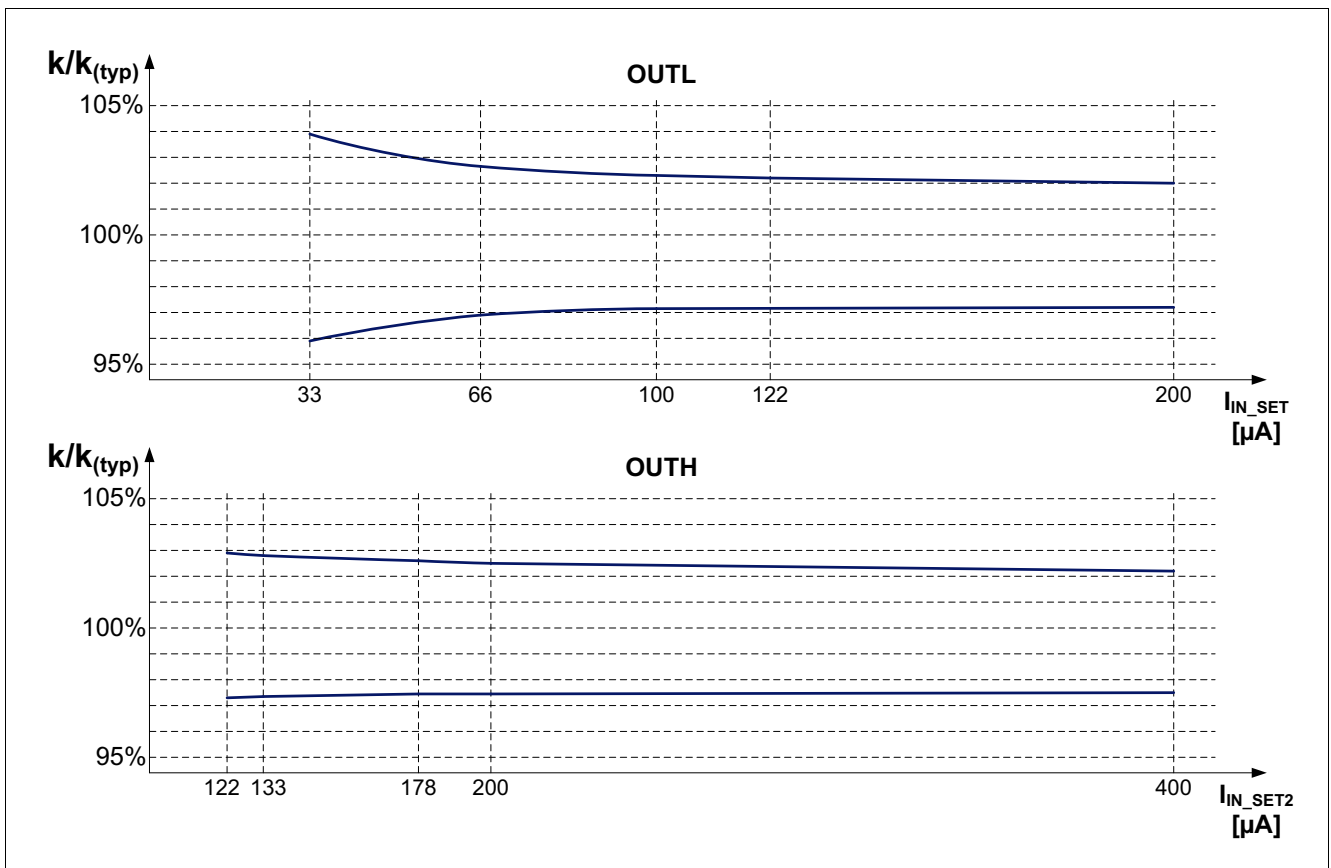

Figure 10 Typical output current accuracy I_{OUT} / I_{IN_SET} at $T_J = 25^\circ\text{C}$

Power stage

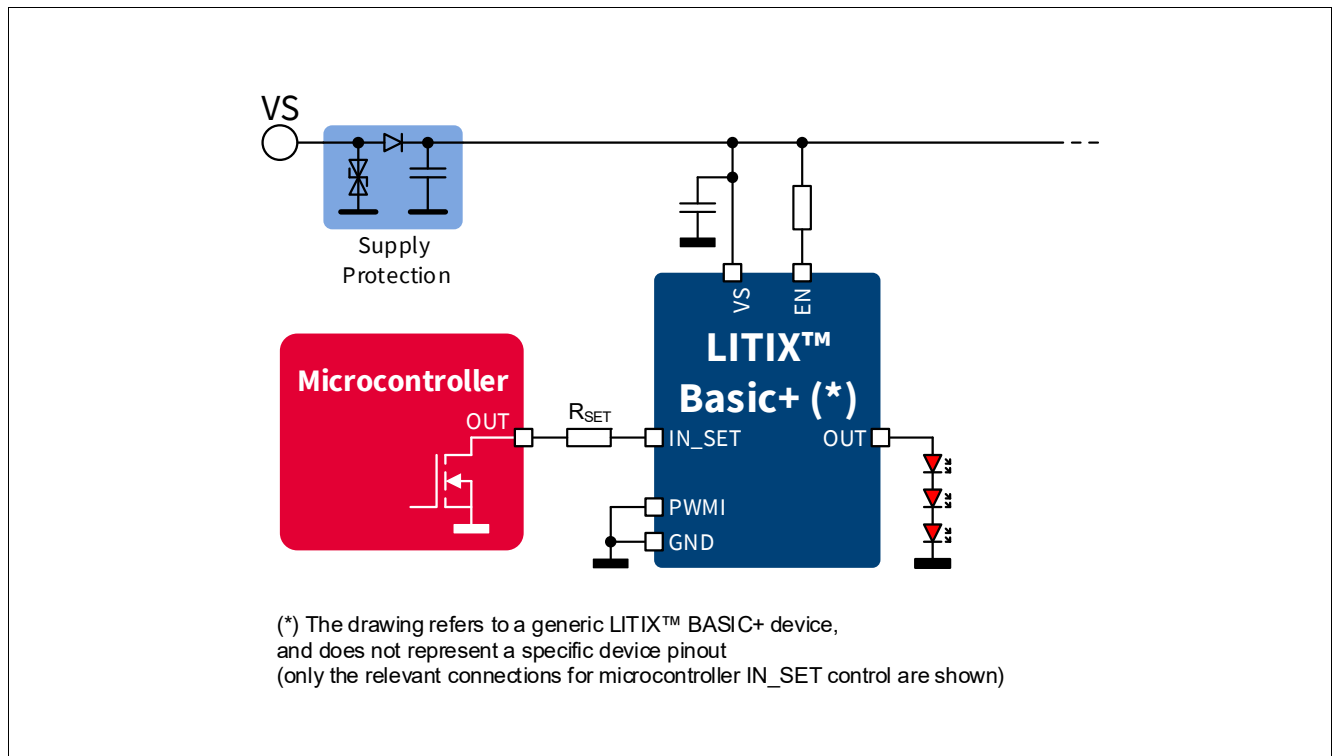

Figure 11 Output control via IN_SET pin and open-drain microcontroller out (simplified diagram)

5.4.4 IN_SET pin behavior during device overload management

If a fault condition arises on the channel controlled by the IN_SET pin, the IN_SET pin is reduced to $I_{IN_SET(fault)}$, in order to minimise the current consumption of the whole device under fault condition.

5.4.5 OUT_SET pin

The OUT_SET pin, mirroring the IN_SET current defined by the external resistor R_{SET} , can be used to define the IN_SET current of an additional companion device.

If minimum IN_SET activation current $I_{IN_SET(act)}$ is not reached the OUT_SET current is reduced to $I_{OUT_SET(OFF)}$. This allows to drive other devices via OUT_SET, even when digital dimming is required, without external components (see application drawing example in [Chapter 7](#)).

Power stage

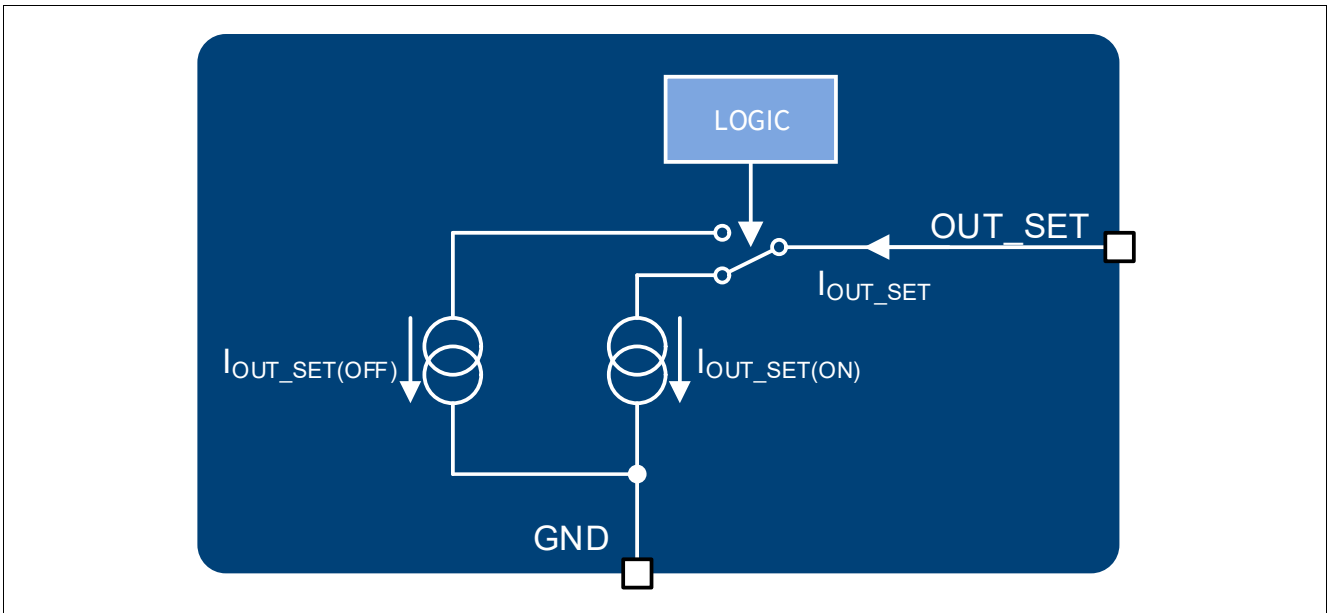

Figure 12 OUT_SET pin block diagram

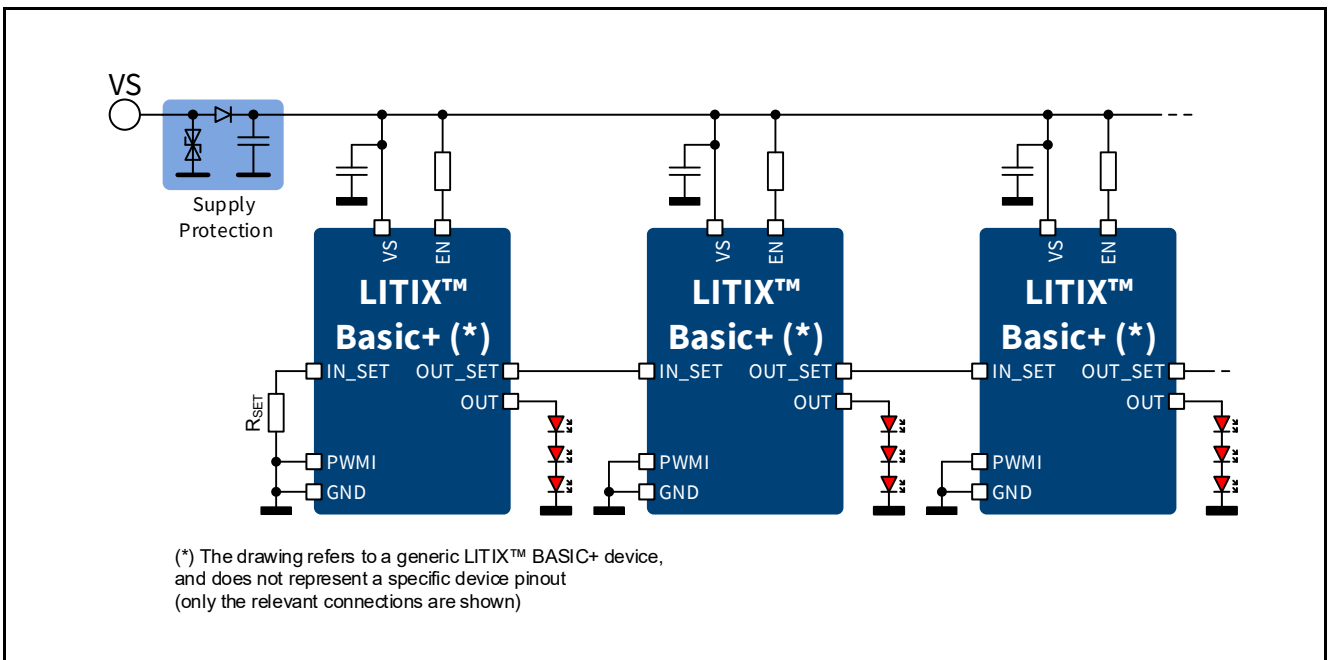

Figure 13 IN_SET to OUT_SET serial connection example

5.4.6 Direct control of PWMI

PWMI input can be controlled by the PWMO output of another device of LITIX™ Basic+ family or, alternatively, a push-pull output stage of a microcontroller: the host device decides the digital dimming characteristics by applying the proper control cycle in order to set the “on”/“off” timing, according to the chosen dimming function.

5.4.7 Timing diagrams

In the following diagram (Figure 14, Figure 16) the influences of inputs on output activation delays are shown.

Power stage

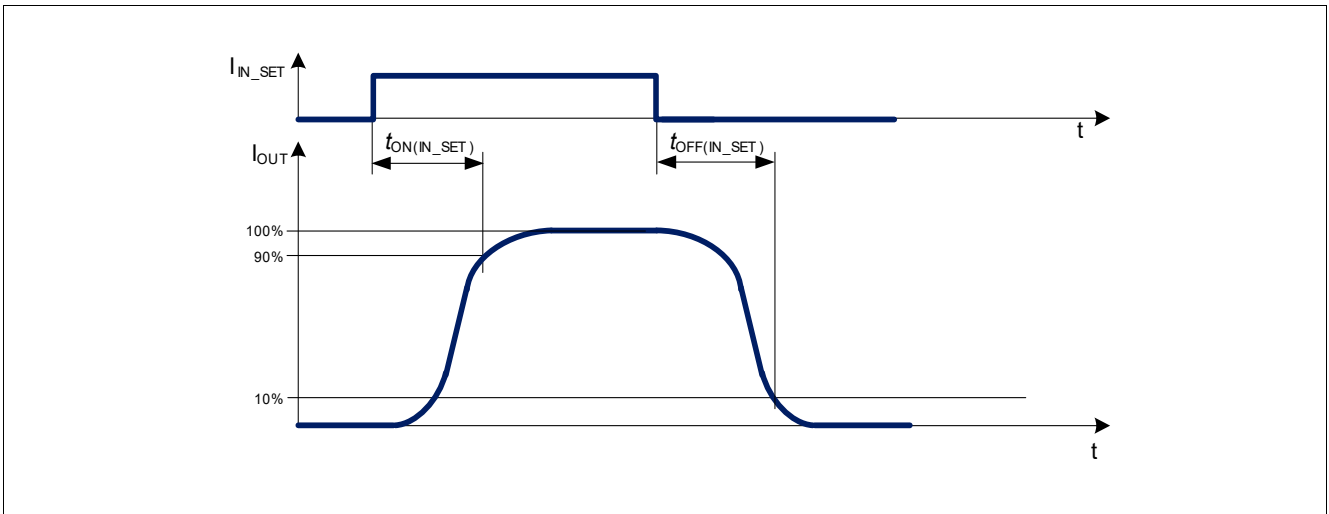

Figure 14 IN_SET turn on and turn off delay timing diagram

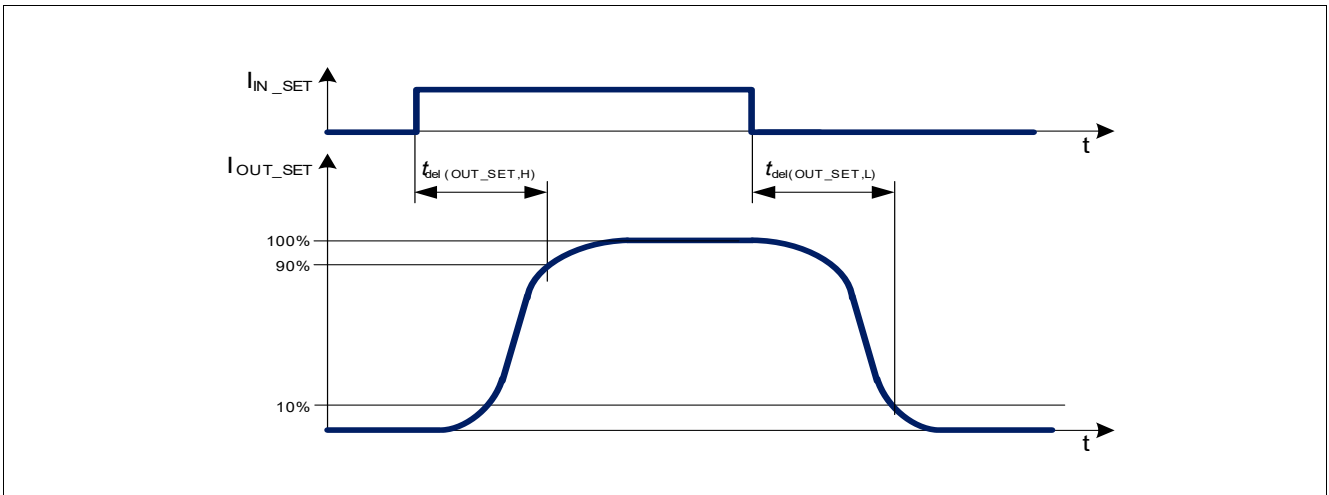

Figure 15 IN_SET to OUT_SET activation and deactivation delay timing diagram

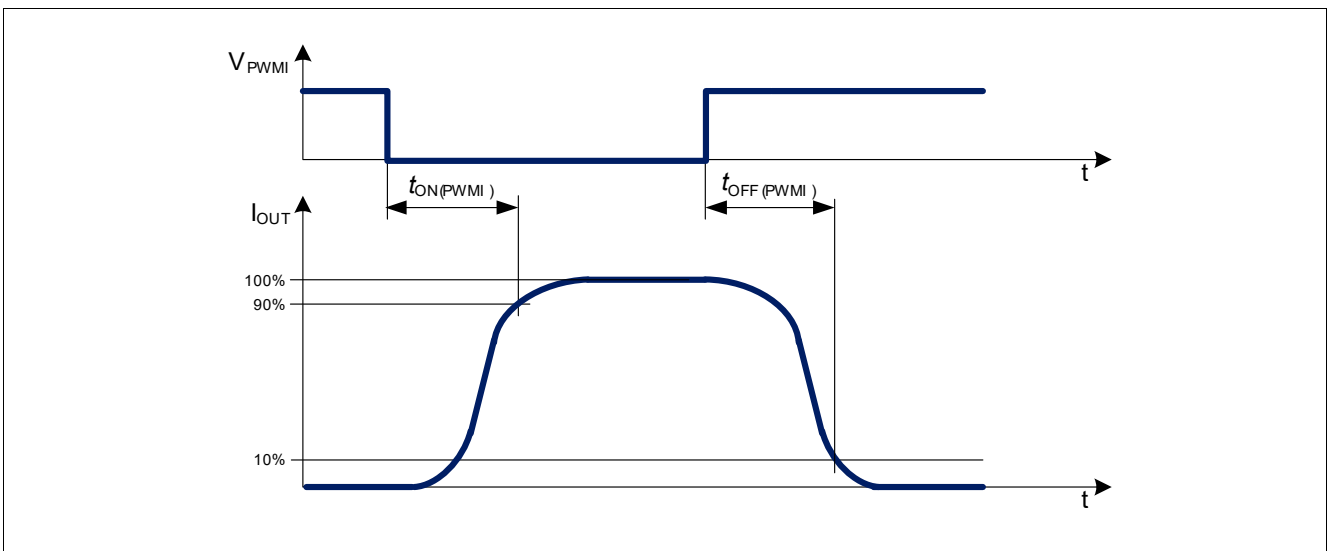

Figure 16 PWMI turn on and turn off timing diagram

Power stage

5.5 Electrical characteristics power stage

Table 7 Electrical characteristics: Power stage and CGF pin

$T_J = -40^\circ\text{C}$ to $+150^\circ\text{C}$; $V_S = 5.5\text{ V}$ to 18 V ; $R_{IN_SET} = 10\text{ k}\Omega$; all voltages with respect to GND, positive current flowing into input and I/O pins, positive current flowing out from output pins (unless otherwise specified)

Parameter	Symbol	Values			Unit	Note or Test Condition	Number
		Min.	Typ.	Max.			
Output leakage current	$I_{OUT(Leak)}$	-	-	9	μA	¹⁾ $V_{EN} = 5.5\text{ V}$ $I_{IN_SET} = 0\ \mu\text{A}$ $V_{OUT} = 2.5\text{ V}$ $T_J = 85^\circ\text{C}$	P_6.5.51
Output leakage current	$I_{OUT(Leak)}$	-	-	21	μA	¹⁾ $V_{EN} = 5.5\text{ V}$ $I_{IN_SET} = 0\ \mu\text{A}$ $V_{OUT} = 2.5\text{ V}$ $T_J = 150^\circ\text{C}$	P_6.5.60
Reverse output current	$I_{OUT(rev)}$	-	-	3	μA	¹⁾ $V_{EN} = V_S$ $V_S = -18\text{ V}$ Output load: LED with break down voltage $< -0.6\text{ V}$	P_6.5.2

Output current accuracy

Output current accuracy I_{OUTL}/I_{IN_SET}	K_{RT}	870	900	930	-	¹⁾ $T_J = 25^\circ\text{C}$ $V_S = 12.8\text{ V}$ $V_{PSL} = 2\text{ V}$ CFG open OUTH open $I_{IN_SET} = 66\ \mu\text{A}$	P_6.5.3
Output current accuracy I_{OUTL}/I_{IN_SET}	K_{LT}	846	900	954	-	¹⁾ $T_J = 25... 150^\circ\text{C}$ $V_S = 8... 18\text{ V}$ $V_{PSL} = 2\text{ V}$ CFG open OUTH open $I_{IN_SET} = 66\ \mu\text{A}$	P_6.5.4
Output current accuracy I_{OUTL}/I_{IN_SET}	K_{ALL}	837	900	963	-	¹⁾ $T_J = -40... 150^\circ\text{C}$ $V_S = 8... 18\text{ V}$ $V_{PSL} = 2\text{ V}$ CFG open OUTH open $I_{IN_SET} = 66\ \mu\text{A}$	P_6.5.5
Output current accuracy I_{OUTL}/I_{IN_SET}	K_{LT}	855	900	945	-	¹⁾ $T_J = 25... 150^\circ\text{C}$ $V_S = 8... 18\text{ V}$ $V_{PSL} = 2\text{ V}$ CFG open OUTH open $I_{IN_SET} = 100... 200\ \mu\text{A}$	P_6.5.6

Power stage

Table 7 Electrical characteristics: Power stage and CGF pin (cont'd)

$T_J = -40^\circ\text{C}$ to $+150^\circ\text{C}$; $V_S = 5.5\text{ V}$ to 18 V ; $R_{IN_SET} = 10\text{ k}\Omega$; all voltages with respect to GND, positive current flowing into input and I/O pins, positive current flowing out from output pins (unless otherwise specified)

Parameter	Symbol	Values			Unit	Note or Test Condition	Number
		Min.	Typ.	Max.			
Output current accuracy I_{OUTL}/I_{IN_SET}	K_{ALL}	842	900	958	–	¹⁾ $T_J = -40\dots 150^\circ\text{C}$ $V_S = 8\dots 18\text{ V}$ $V_{PSL} = 2\text{ V}$ CFG open OUTH open $I_{IN_SET} = 100\dots 200\ \mu\text{A}$	P_6.5.7
Output current accuracy I_{OUTH}/I_{IN_SET}	K_{RT}	861	890	919	–	¹⁾ $T_J = 25^\circ\text{C}$ $V_S = 12.8\text{ V}$ $V_{PSH} = 2\text{ V}$ $V_{CFG} = 0\text{ V}$ OUTL open $I_{IN_SET} = 133\ \mu\text{A}$	P_6.5.8
Output current accuracy I_{OUTH}/I_{IN_SET}	K_{LT}	837	890	943	–	¹⁾ $T_J = 25\dots 150^\circ\text{C}$ $V_S = 8\dots 18\text{ V}$ $V_{PSH} = 2\text{ V}$ $V_{CFG} = 0\text{ V}$ OUTL open $I_{IN_SET} = 133\ \mu\text{A}$	P_6.5.9
Output current accuracy I_{OUTH}/I_{IN_SET}	K_{ALL}	828	890	952	–	¹⁾ $T_J = -40\dots 150^\circ\text{C}$ $V_S = 8\dots 18\text{ V}$ $V_{PS} = 2\text{ V}$ $V_{CFG} = 0\text{ V}$ OUTL open $I_{IN_SET} = 133\ \mu\text{A}$	P_6.5.10
Output current accuracy I_{OUTH}/I_{IN_SET}	K_{LT}	855	890	925	–	¹⁾ $T_J = 25\dots 150^\circ\text{C}$ $V_S = 8\dots 18\text{ V}$ $V_{PSH} = 2\text{ V}$ $V_{CFG} = 0\text{ V}$ OUTL open $I_{IN_SET} = 200\dots 400\ \mu\text{A}$	P_6.5.11
Output current accuracy I_{OUTH}/I_{IN_SET}	K_{ALL}	846	890	934	–	¹⁾ $T_J = -40\dots 150^\circ\text{C}$ $V_S = 8\dots 18\text{ V}$ $V_{PSH} = 2\text{ V}$ $V_{CFG} = 0\text{ V}$ OUTL open $I_{IN_SET} = 200\dots 400\ \mu\text{A}$	P_6.5.12
Required voltage drop during current control $V_{PS(CC)} = V_S - V_{OUT}$	$V_{PS(CC)}$	1.0	–	–	V	²⁾ $V_S = 8\dots 18\text{ V}$ $I_{OUT} > 90\%$ of $K_{(typ)} * I_{IN_SET}$	P_6.5.36

Power stage

Table 7 Electrical characteristics: Power stage and CGF pin (cont'd)

$T_J = -40^\circ\text{C}$ to $+150^\circ\text{C}$; $V_S = 5.5\text{ V}$ to 18 V ; $R_{IN_SET} = 10\text{ k}\Omega$; all voltages with respect to GND, positive current flowing into input and I/O pins, positive current flowing out from output pins (unless otherwise specified)

Parameter	Symbol	Values			Unit	Note or Test Condition	Number
		Min.	Typ.	Max.			
Required voltage drop during high current control $V_{PSH(CC)} = V_S - V_{OUTH}$	$V_{PSH(CC)}$	0.65	–	–	V	$V_S = 8... 18\text{ V}$ $V_{CFG} = 0\text{ V}$ OUTL open $I_{IN_SET} = 400\ \mu\text{A}$ $I_{OUTH} > 90\%$ of $K_{(typ)} * I_{IN_SET}$ $T_J = -40^\circ\text{C}$	P_6.5.49
Required voltage drop during high current control $V_{PSH(CC)} = V_S - V_{OUTH}$	$V_{PSH(CC)}$	0.75	–	–	V	$V_S = 8... 18\text{ V}$ $V_{CFG} = 0\text{ V}$ OUTL open $I_{IN_SET} = 400\ \mu\text{A}$ $I_{OUTH} > 90\%$ of $K_{(typ)} * I_{IN_SET}$ $T_J = 25^\circ\text{C}$	P_6.5.61
Required voltage drop during high current control $V_{PSH(CC)} = V_S - V_{OUTH}$	$V_{PSH(CC)}$	0.85	–	–	V	$V_S = 8... 18\text{ V}$ $V_{CFG} = 0\text{ V}$ OUTL open $I_{IN_SET} = 400\ \mu\text{A}$ $I_{OUTH} > 90\%$ of $K_{(typ)} * I_{IN_SET}$ $T_J = 150^\circ\text{C}$	P_6.5.62
Required voltage drop during low current control $V_{PSL(CC)} = V_S - V_{OUTL}$	$V_{PSL(CC)}$	0.65	–	–	V	$V_S = 8... 18\text{ V}$ CFG open OUTH open $I_{IN_SET} = 200\ \mu\text{A}$ $I_{OUTL} > 90\%$ of $K_{(typ)} * I_{IN_SET}$ $T_J = -40^\circ\text{C}$	P_6.5.50
Required voltage drop during low current control $V_{PSL(CC)} = V_S - V_{OUTL}$	$V_{PSL(CC)}$	0.75	–	–	V	$V_S = 8... 18\text{ V}$ CFG open OUTH open $I_{IN_SET} = 200\ \mu\text{A}$ $I_{OUTL} > 90\%$ of $K_{(typ)} * I_{IN_SET}$ $T_J = 25^\circ\text{C}$	P_6.5.63
Required voltage drop during low current control $V_{PSL(CC)} = V_S - V_{OUTL}$	$V_{PSL(CC)}$	0.85	–	–	V	$V_S = 8... 18\text{ V}$ CFG open OUTH open $I_{IN_SET} = 200\ \mu\text{A}$ $I_{OUTL} > 90\%$ of $K_{(typ)} * I_{IN_SET}$ $T_J = 150^\circ\text{C}$	P_6.5.64

Power stage

Table 7 Electrical characteristics: Power stage and CGF pin (cont'd)

$T_J = -40^\circ\text{C}$ to $+150^\circ\text{C}$; $V_S = 5.5\text{ V}$ to 18 V ; $R_{IN_SET} = 10\text{ k}\Omega$; all voltages with respect to GND, positive current flowing into input and I/O pins, positive current flowing out from output pins (unless otherwise specified)

Parameter	Symbol	Values			Unit	Note or Test Condition	Number
		Min.	Typ.	Max.			
Required supply voltage for current control	$V_{S(CC)}$	5.5	–	–	V	$V_{EN} = 5.5\text{ V}$ $V_{OUT} = 3\text{ V}$ $R_{IN_SET} = 6.8\text{ k}\Omega$ $I_{OUT} > 90\%$ of $K^*I_{IN_SET}$	P_6.5.40
Required output voltage for current control	$V_{OUT(CC)}$	1.4	–	–	V	$V_S = 8\dots 18\text{ V}$ $I_{OUT} > 90\%$ of $K^*I_{IN_SET}$	P_6.5.41
CFG required voltage for low drop at high current	$V_{CFG(L)}$	–	–	1.35	V	$V_S = 8\text{ V}$ to 18 V $V_{EN} = 5.5\text{ V}$	P_6.5.46
CFG required voltage for high accuracy at low output current range	$V_{CFG(H)}$	2	–	–	V	$V_S = 8\text{ V}$ to 18 V $V_{EN} = 5.5\text{ V}$	P_6.5.47
CFG pull-up current	$I_{CFG(PU)}$	20	35	50	μA	$V_S = 8\text{ V}$ to 18 V $V_{EN} = 5.5\text{ V}$	P_6.5.48
Overtemperature shutdown threshold	T_{JSD}	150	175	190	$^\circ\text{C}$	¹⁾	P_6.5.42
Overtemperature hysteresis	$T_{J(hys)}$	–	10	–	$^\circ\text{C}$	¹⁾	P_6.5.43

1) Not subjected to production test: specified by design.

2) In these test conditions, the parameter $K_{(typ)}$ represents the typical value of output current accuracy.

Power stage

5.6 Electrical characteristics IN_SET, OUT_SET, PWR_SHS, PWM_SHG and PWMI pins for output settings

Table 8 Electrical characteristics: IN_SET, OUT_SET, PWR_SHS, PWM_SHG and PWMI pins

$T_J = -40^\circ\text{C}$ to $+150^\circ\text{C}$; $V_S = 5.5\text{ V}$ to 18 V ; $R_{IN_SET} = 10\text{ k}\Omega$; all voltages with respect to GND, positive current flowing into input and I/O pins, positive current flowing out from output pins (unless otherwise specified)

Parameter	Symbol	Values			Unit	Note or Test Condition	Number
		Min.	Typ.	Max.			
IN_SET reference voltage	$V_{IN_SET(ref)}$	1.195	1.22	1.245	V	¹⁾ $V_{EN} = 5.5\text{ V}$ $T_J = 25^\circ\text{C}$	P_6.6.1
IN_SET reference voltage	$V_{IN_SET(ref)}$	1.184	1.22	1.256	V	¹⁾ $V_{EN} = 5.5\text{ V}$	P_6.6.17
IN_SET output activation current	$I_{IN_SET(ACT)}$	–	–	15	μA	$V_{EN} = 5.5\text{ V}$ $V_{PS} = 3\text{ V}$ $I_{OUT} > 50\%$ of $K_{(typ)} * I_{IN_SET}$	P_6.6.2
OUT_SET output current matching	$\Delta I_{OUT_SET(ON)}/I_{N_SET}$	-4	–	4	%	$V_S = 8\text{ V}$ to 18 V $V_{OUT_SET} = 1.2\text{ V}$ $I_{IN_SET} = 267\text{ }\mu\text{A}$	P_6.6.3
PWR_SHG pull up current	$I_{PWR_SHG(PU)}$	100	180	260	μA	$V_S = 8\text{ V}$ to 18 V $V_{EN} = 5.5\text{ V}$ $V_{PWMI} = 1.5\text{ V}$ $V_{PS} = 3\text{ V}$ $V_{PWR_SHG} - V_{PWR_SHS} = 2\text{ V}$	P_6.6.14
PWR_SHG pull-down current	$I_{PWR_SHG(PD)}$	1.5	2.1	3	mA	$V_S = 8\text{ V}$ to 18 V $V_{EN} = 5.5\text{ V}$ $V_{PWMI} = 3\text{ V}$ $V_{PS} = 3\text{ V}$ $V_{PWR_SHG} - V_{PWR_SHS} = 0.8\text{ V}$	P_6.6.15
PWR_SHG clamping voltage $V_{PWR_SHG} - V_{PWR_SHS}$	$V_{GS(PWR_SH)}$	4.5	–	6	V	$V_S = 12\text{ V}$ to 18 V $V_{EN} = 5.5\text{ V}$ $V_{PSL/H} > 7\text{ V}$	P_6.6.16
PWMI low threshold	$V_{PWMI(L)}$	1.5	1.7	2	V	$V_S = 8\text{ V}$ to 18 V $V_{EN} = 5.5\text{ V}$	P_6.6.6
PWMI high threshold	$V_{PWMI(H)}$	2.5	2.7	3	V	$V_S = 8\text{ V}$ to 18 V $V_{EN} = 5.5\text{ V}$	P_6.6.7

Timing

IN_SET turn on time	$t_{ON(IN_SET)}$	–	–	20	μs	¹⁾²⁾ $V_S = 13.5\text{ V}$ $V_{PS} = 4\text{ V}$ I_{IN_SET} rising from 0 to $180\text{ }\mu\text{A}$ $I_{OUT} = 90\%$ of $K * I_{IN_SET}$	P_6.6.8
---------------------	-------------------	---	---	----	---------------	---	---------

Power stage

Table 8 Electrical characteristics: IN_SET, OUT_SET, PWR_SHS, PWM_SHG and PWMI pins (cont'd)

$T_J = -40^\circ\text{C}$ to $+150^\circ\text{C}$; $V_S = 5.5\text{ V}$ to 18 V ; $R_{IN_SET} = 10\text{ k}\Omega$; all voltages with respect to GND, positive current flowing into input and I/O pins, positive current flowing out from output pins (unless otherwise specified)

Parameter	Symbol	Values			Unit	Note or Test Condition	Number
		Min.	Typ.	Max.			
IN_SET turn off time	$t_{OFF(IN_SET)}$	–	–	10	μs	¹⁾²⁾ $V_S = 13.5\text{ V}$ $V_{PS} = 4\text{ V}$ I_{IN_SET} falling from 180 to 0 μA $I_{OUT} = 10\%$ of $K \cdot I_{IN_SET}$	P_6.6.9
OUT_SET activation time	$t_{del(OUT_SET,H)}$	–	–	5	μs	¹⁾³⁾ $V_S = 13.5\text{ V}$ I_{IN_SET} rising from 0 to 180 μA $I_{OUT_SET} = 90\%$ of I_{IN_SET}	P_6.6.10
OUT_SET deactivation time	$t_{del(OUT_SET,L)}$	–	–	5	μs	¹⁾³⁾ $V_S = 13.5\text{ V}$ I_{IN_SET} falling from 180 to 0 μA $I_{OUT_SET} = 10\%$ of I_{IN_SET}	P_6.6.11
PWMI turn on time	$t_{ON(PWMI)}$	–	–	15	μs	¹⁾⁴⁾ $V_S = 8\text{ V}$ to 18 V $V_{EN} = 5.5\text{ V}$ V_{PWMI} falling from 5 V to 0 V $I_{OUT} = 90\%$ of $K \cdot I_{IN_SET}$	P_6.6.12
PWMI turn off time	$t_{OFF(PWMI)}$	–	–	10	μs	¹⁾⁴⁾ $V_S = 8\text{ V}$ to 18 V $V_{EN} = 5.5\text{ V}$ $V_{PWMI} = 0$ rising from 0 V to 5 V $I_{OUT} = 10\%$ of $K \cdot I_{IN_SET}$	P_6.6.13

1) Not subjected to production test: specified by design.

2) Refer to [Figure 14](#).

3) Refer to [Figure 15](#).

4) Refer to [Figure 16](#).

6 Overload diagnosis

6.1 Error management via ERRN

6.1.1 ERRN pin

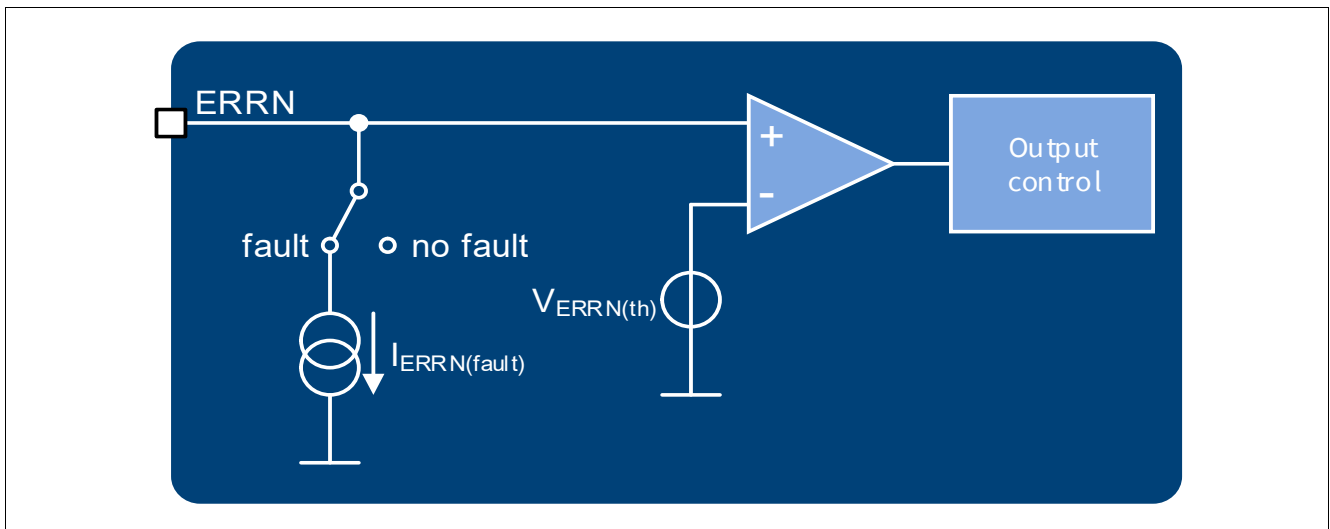

Figure 17 ERRN pin (block diagram)

The device is able to report an overtemperature failure in its driven load and react to a fault detected by another LED driver in the system if a shared error network is implemented (i. e. driving LED chains of the same light function). This is possible with the usage of an external pull-up resistor, allowing multiple devices to share the open drain diagnosis output pin ERRN. All devices sharing the common error network are capable to detect the fault from any of the channels driven by the LITIX™ Basic+ LED drivers and, if desired, to switch multiple loads off.

Overload diagnosis

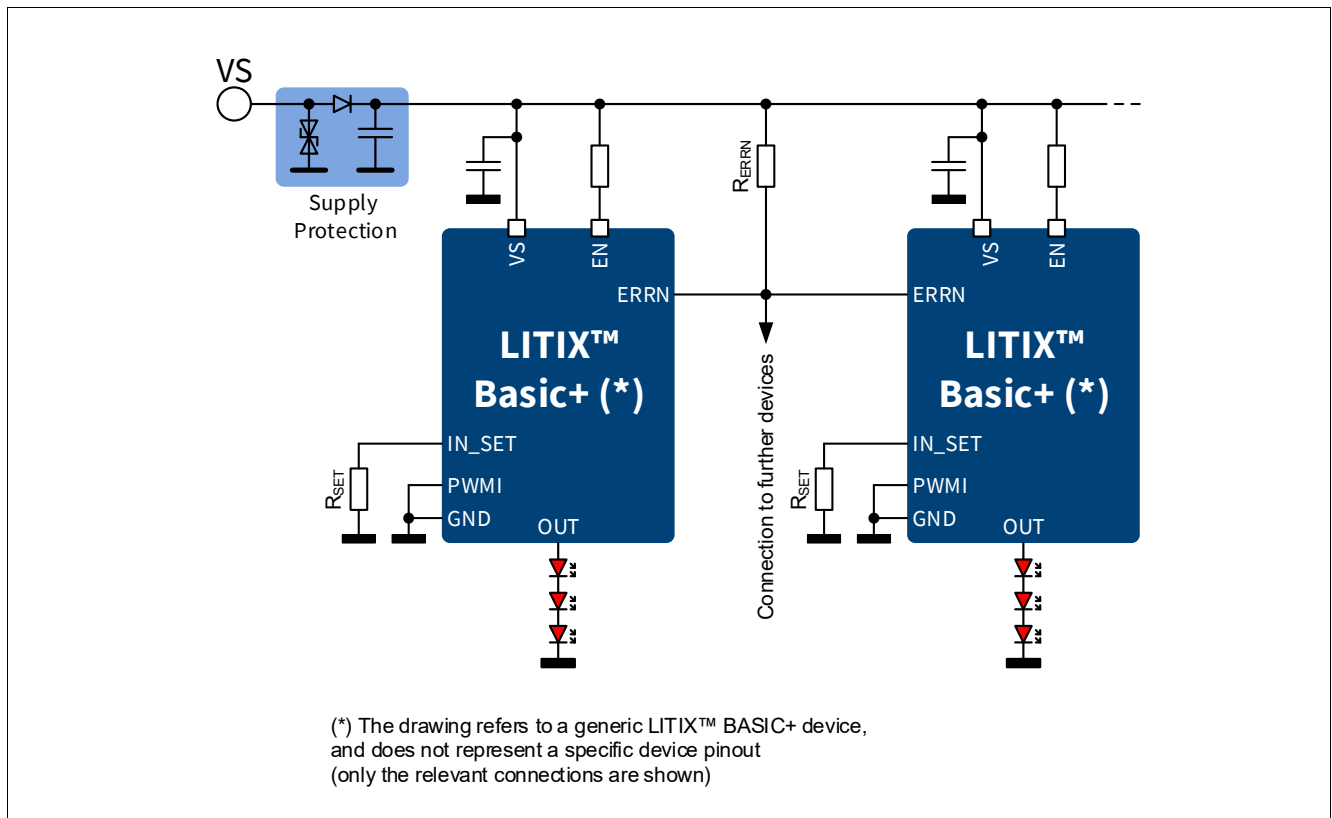

Figure 18 Shared error network principle between LITIX™ Basic+ family devices

When the channel is detected to be under fault conditions (for, at least, a filter time t_{fault}), the open-drain ERRN pin sinks a pull-down current $I_{\text{ERRN}(\text{fault})}$ toward GND. Therefore an active low state can be detected at ERRN pin when $V_{\text{ERRN}} < V_{\text{ERRN}(\text{fault})}$ and if this condition is reached, the channel is switched off. Similarly, when the fault is removed, ERRN pin is put back in high impedance state, and the channels reactivation procedure can be completed as illustrated in the timing diagrams in this chapter.

6.2 Fault management

Under overtemperature condition the ERRN pin starts sinking a current, $I_{\text{ERRN}(\text{PD})}$ to ground and the voltage level on this pin will drop below $V_{\text{ERRN}(\text{fault})}$ if the external pull-up resistor is properly dimensioned. The ERRN low voltage can also be used as input signal for a μC to perform the desired diagnosis policy. The IN_SET pin goes in a weak pull-down state with a current consumption $I_{\text{IN_SET}(\text{fault})}$ after an additional latency time $t_{\text{IN_SET}(\text{del})}$.

The fault status is not latched: as soon as the overtemperature condition is no longer present (at least for a filter time t_{fault}), ERRN goes back to high impedance and, when its voltage is above $V_{\text{ERRN}(\text{fault})}$, the IN_SET voltage goes up to $V_{\text{SET}(\text{ref})}$, again after a time $t_{\text{IN_SET}(\text{del})}$. Finally the output stage will be activated again after a time $t_{\text{ERR}(\text{reset})}$, which takes into account also the additional latency which depends on the external ERRN circuitry.

An example of error diagnosis conditions is shown in the timing diagram of [Figure 19](#).

Overload diagnosis

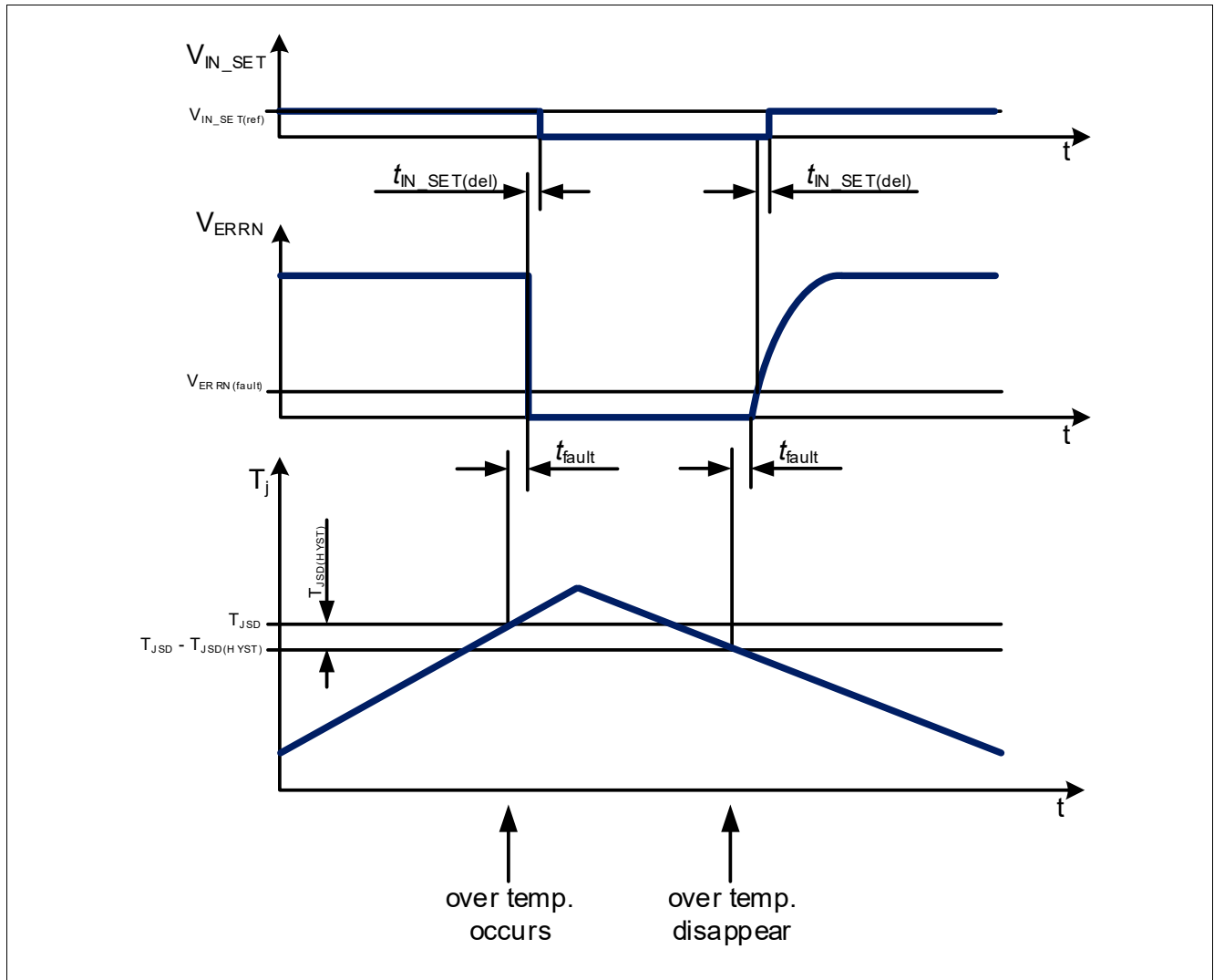

Figure 19 Overtemperature condition timing diagram example

6.3 Electrical characteristics: Overload management

Table 9 Electrical Characteristics: Fault management

$T_j = -40^{\circ}\text{C}$ to $+150^{\circ}\text{C}$; $V_S = 5.5\text{ V}$ to 18 V ; $R_{IN_SET} = 10\text{ k}\Omega$; all voltages with respect to GND, positive current flowing into input and I/O pins, positive current flowing out from output pins (unless otherwise specified)

Parameter	Symbol	Values			Unit	Note or Test Condition	Number
		Min.	Typ.	Max.			
IN_SET fault current	$I_{IN_SET(fault)}$	-	-	10	μA	¹⁾ $V_S > 8\text{ V}$ $V_{OUT} = 3.6\text{ V}$ $V_{ERRN} = 0\text{ V}$ $V_{IN_SET} = 1\text{ V}$ $V_{EN} > V_{EN(th,max)}$	P_7.5.1
ERRN fault current	$I_{ERRN(fault)}$	2	-	-	mA	¹⁾ $V_S > 8\text{ V}$ $V_{ERRN} = 0.8\text{ V}$ Overtemperature condition $V_{EN} > V_{EN(th,max)}$	P_7.5.2

Overload diagnosis

Table 9 Electrical Characteristics: Fault management (cont'd)

$T_J = -40^\circ\text{C}$ to $+150^\circ\text{C}$; $V_S = 5.5\text{ V}$ to 18 V ; $R_{\text{IN_SET}} = 10\text{ k}\Omega$; all voltages with respect to GND, positive current flowing into input and I/O pins, positive current flowing out from output pins (unless otherwise specified)

Parameter	Symbol	Values			Unit	Note or Test Condition	Number
		Min.	Typ.	Max.			
ERRN input threshold	$V_{\text{ERRN(th)}}$	0.8	–	2.0	V	¹⁾ $V_S > 8\text{ V}$	P_7.5.3

Timing

Fault deactivation delay	t_{fault}	40	–	150	μs	¹⁾ $V_S > 8\text{ V}$ ²⁾ V_{OUT} falling from 5 V to 0 V or overtemperature condition $V_{\text{EN}} > V_{\text{EN(th, max)}}$	P_7.5.19
Fault appearance/removal to IN_SET deactivation/activation delay	$t_{\text{IN_SET(del)}}$	–	–	10	μs	¹⁾ $V_S > 8\text{ V}$ ERRN falling from 5 V to 0 V $V_{\text{EN}} > V_{\text{EN(th, max)}}$	P_7.5.4

- 1) Not subjected to production test: specified by design.
- 2) ERRN status only changed during overtemperature condition

Application information

7 Application information

Note: The following information is given as a hint for the implementation of the device only and shall not be regarded as a description or warranty of a certain functionality, condition or quality of the device.

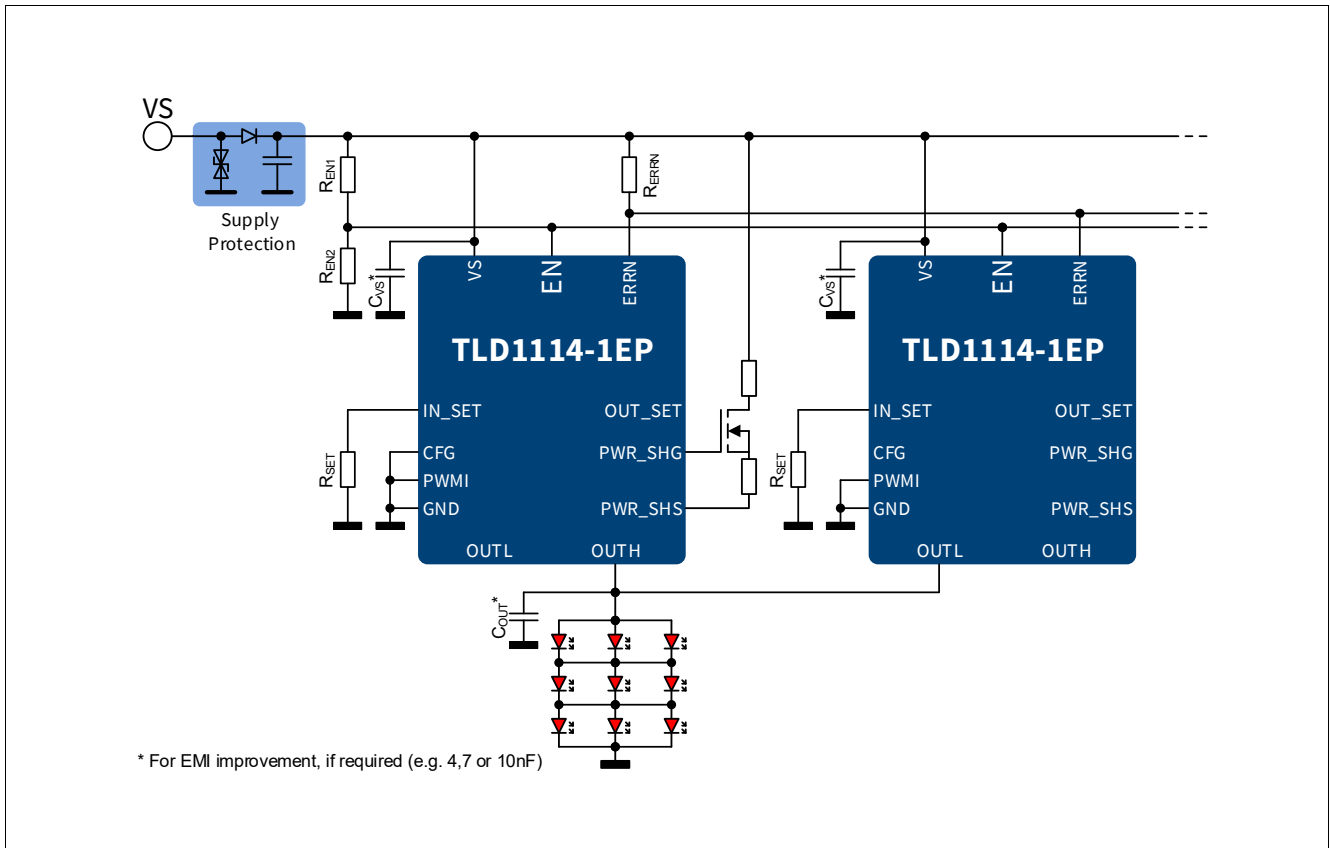

Figure 20 Application diagram example

Note: This is a very simplified example of an application circuit. The function must be verified in the real application.

Package outline

8 Package outline

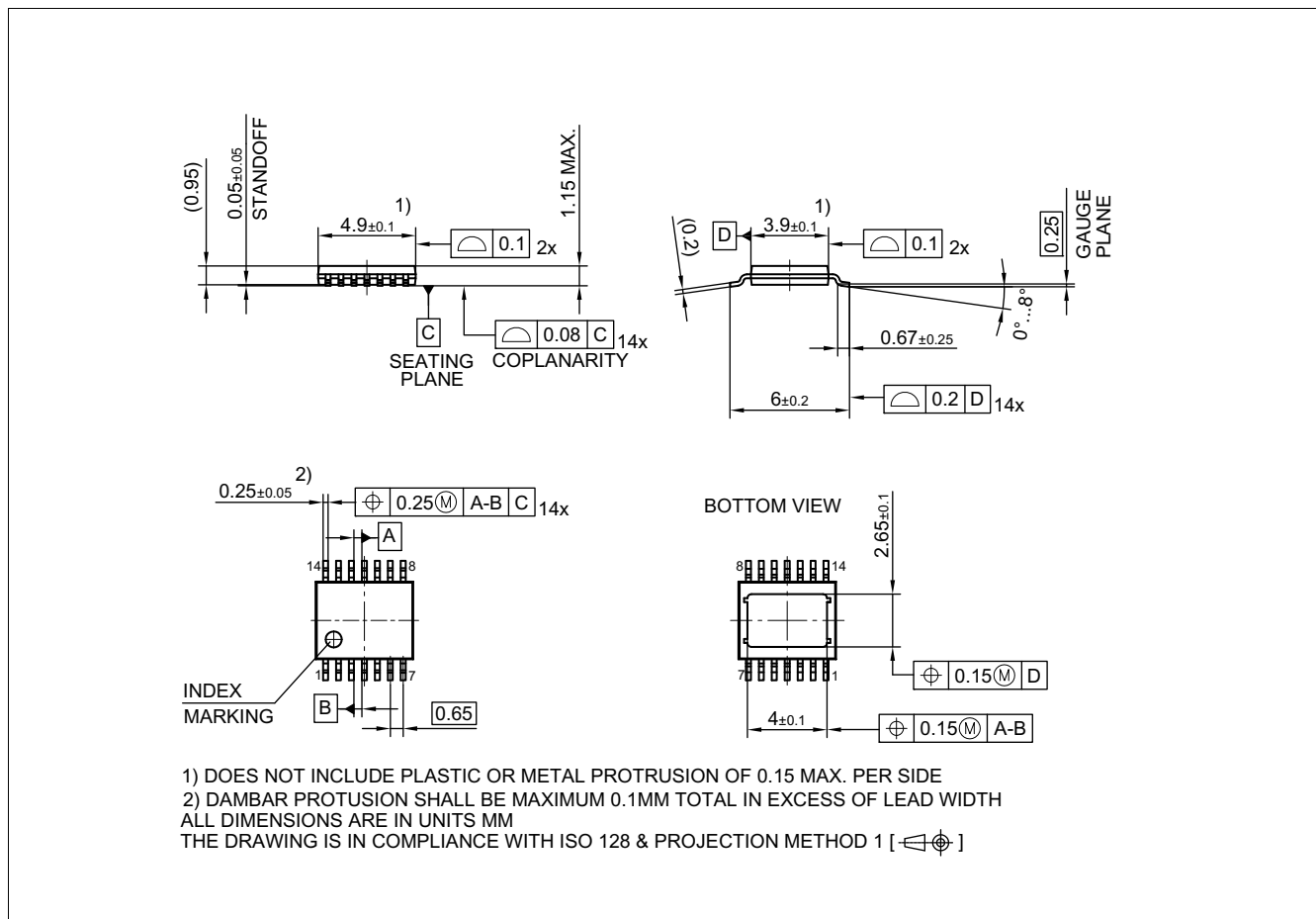

Figure 21 PG-TSDSO-14

Green product (RoHS compliant)

To meet the world-wide customer requirements for environmentally friendly products and to be compliant with government regulations the device is available as a green product. Green products are RoHS-Compliant (i.e Pb-free finish on leads and suitable for Pb-free soldering according to IPC/JEDEC J-STD-020).

Further information on packages

<https://www.infineon.com/packages>

Revision History

9 Revision History

Revision	Date	Changes
1.00	2018-10-09	Initial datasheet created

Trademarks

All referenced product or service names and trademarks are the property of their respective owners.

Edition 2018-10-09

Published by

Infineon Technologies AG

81726 Munich, Germany

© 2018 Infineon Technologies AG.

All Rights Reserved.

Do you have a question about any aspect of this document?

Email: erratum@infineon.com

Document reference

LITIX™ Basic+ TLD1114-1EP

IMPORTANT NOTICE

The information given in this document shall in no event be regarded as a guarantee of conditions or characteristics ("Beschaffheitsgarantie").

With respect to any examples, hints or any typical values stated herein and/or any information regarding the application of the product, Infineon Technologies hereby disclaims any and all warranties and liabilities of any kind, including without limitation warranties of non-infringement of intellectual property rights of any third party.

In addition, any information given in this document is subject to customer's compliance with its obligations stated in this document and any applicable legal requirements, norms and standards concerning customer's products and any use of the product of Infineon Technologies in customer's applications.

The data contained in this document is exclusively intended for technically trained staff. It is the responsibility of customer's technical departments to evaluate the suitability of the product for the intended application and the completeness of the product information given in this document with respect to such application.

For further information on technology, delivery terms and conditions and prices, please contact the nearest Infineon Technologies Office (www.infineon.com).

WARNINGS

Due to technical requirements products may contain dangerous substances. For information on the types in question please contact your nearest Infineon Technologies office.

Except as otherwise explicitly approved by Infineon Technologies in a written document signed by authorized representatives of Infineon Technologies, Infineon Technologies' products may not be used in any applications where a failure of the product or any consequences of the use thereof can reasonably be expected to result in personal injury.

X-ON Electronics

Largest Supplier of Electrical and Electronic Components

Click to view similar products for [LED Lighting Drivers](#) category:

Click to view products by [Infineon](#) manufacturer:

Other Similar products are found below :

[LV5235V-MPB-H](#) [MB39C602PNF-G-JNEFE1](#) [MIC2871YMK-T5](#) [AL1676-10BS7-13](#) [AL1676-20AS7-13](#) [AP5726WUG-7](#) [MX877RTR](#)
[ICL8201](#) [IS31BL3228B-UTLS2-TR](#) [IS31BL3506B-TTLS2-TR](#) [AL3157F-7](#) [AP5725FDCG-7](#) [AP5726FDCG-7](#) [LV52204MTTBG](#)
[AP5725WUG-7](#) [STP4CMPQTR](#) [NCL30086BDR2G](#) [CAT4004BHU2-GT3](#) [LV52207AXA-VH](#) [AP1694AS-13](#) [TLE4242EJ](#) [AS3688](#)
[IS31LT3172-GRLS4-TR](#) [TLD2311EL](#) [KTD2694EDQ-TR](#) [KTZ8864EJAA-TR](#) [IS32LT3174-GRLA3-TR](#) [ZXLD1374QESTTC](#) [MP2488DN-](#)
[LF-Z](#) [NLM0010XTSA1](#) [AL1676-20BS7-13](#) [MPQ7220GF-AEC1-P](#) [MPQ4425BGJ-AEC1-P](#) [MPQ7220GF-AEC1-Z](#) [MPQ4425BGJ-AEC1-Z](#)
[IS31FL3737B-QFLS4-TR](#) [IS31FL3239-QFLS4-TR](#) [KTD2058EUAC-TR](#) [KTD2037EWE-TR](#) [DIO5662ST6](#) [IS31BL3508A-TTLS2-TR](#)
[MAX20052CATC/V+](#) [MAX25606AUP/V+](#) [BD6586MUV-E2](#) [BD9206EFV-E2](#) [BD9416FS-E2](#) [LYT4227E](#) [LYT6079C-TL](#) [MP3394SGF-P](#)
[MP4689AGN-P](#)