

# SEPIC evaluation kit

## TLD5099EP

### About this document

#### Product description

The TLD5099EP is an AEC qualified DC/DC boost controller, especially designed to drive LEDs.

- Built in diagnosis and protection features
- Pulse width modulator to implement a dimming function with reduced color shifting
- Spread spectrum modulator to improve the EMI performance

#### Scope and purpose

Scope of this user manual is to provide to the audience instructions on usage of TLD5099EP SEPIC evaluation board.

#### Intended audience

This document is intended for engineers who need to perform measurements and check performances with TLD5099EP SEPIC evaluation board.

### Table of contents

	<b>About this document</b> .....	1
	<b>Table of contents</b> .....	1
<b>1</b>	<b>Description</b> .....	2
<b>2</b>	<b>Quick start procedure</b> .....	4
<b>3</b>	<b>Current adjustment</b> .....	5
<b>4</b>	<b>Power derating (Battery dependent current)</b> .....	6
<b>5</b>	<b>Embedded PWM engine</b> .....	7
<b>6</b>	<b>Cold crank survival circuit</b> .....	8
<b>7</b>	<b>Schematics</b> .....	9
<b>8</b>	<b>PCB layout</b> .....	12
<b>9</b>	<b>Bill of material</b> .....	13
<b>10</b>	<b>Efficiency measurements</b> .....	15
<b>11</b>	<b>Maximizing efficiency</b> .....	16
<b>12</b>	<b>Minimizing EMI emissions</b> .....	17
<b>13</b>	<b>Revision history</b> .....	18
	<b>Disclaimer</b> .....	19

## 1 Description

### 1 Description

Evaluation board for high power LED application with TLD5099EP product in SEPIC topology.

Default configuration of the board is SEPIC topology without any additional features enabled. In this configuration, it can deliver up to 21 W to the load with an efficiency above 84%. Auxiliary circuits to protect the DC/DC and the load during short to ground are present.

The board is also equipped with the following features, enabled by jumpers:

- Output current adjustment trimmer
- Power derating circuitry
- Embedded PWM engine
- Cold Crank Survival Circuit (**CCSC**)

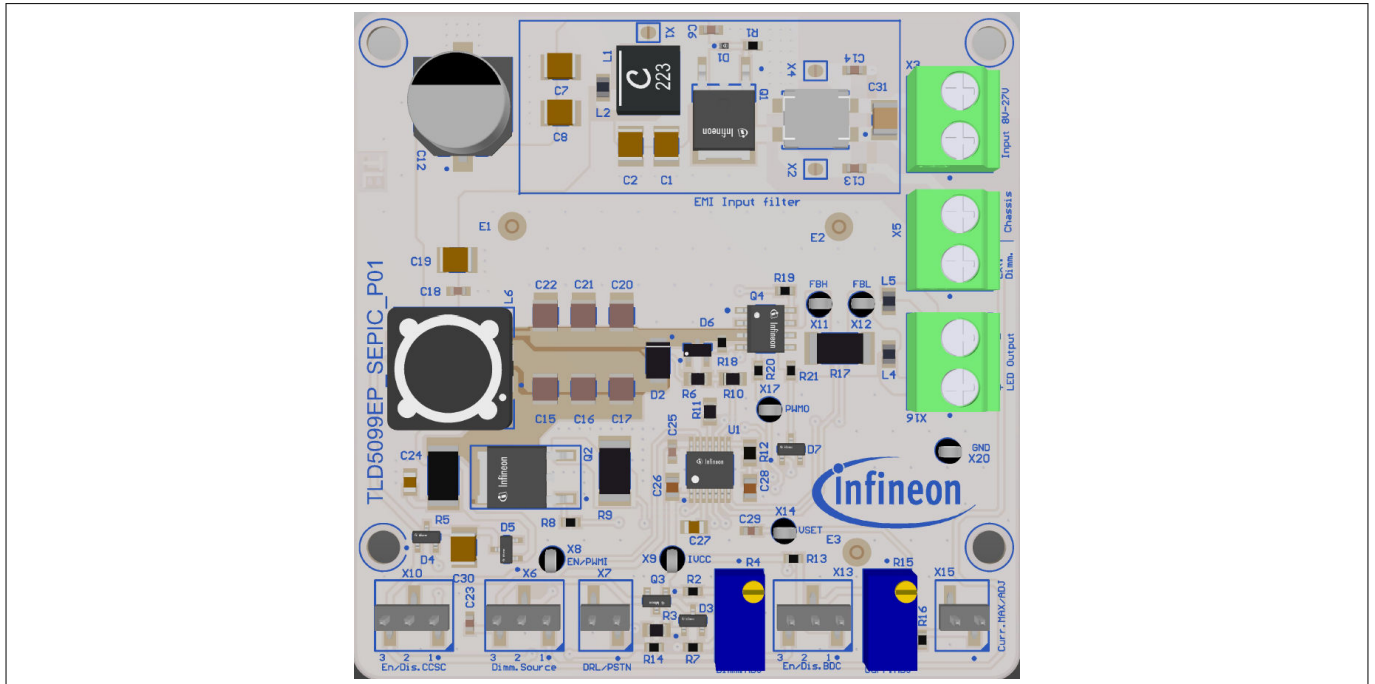
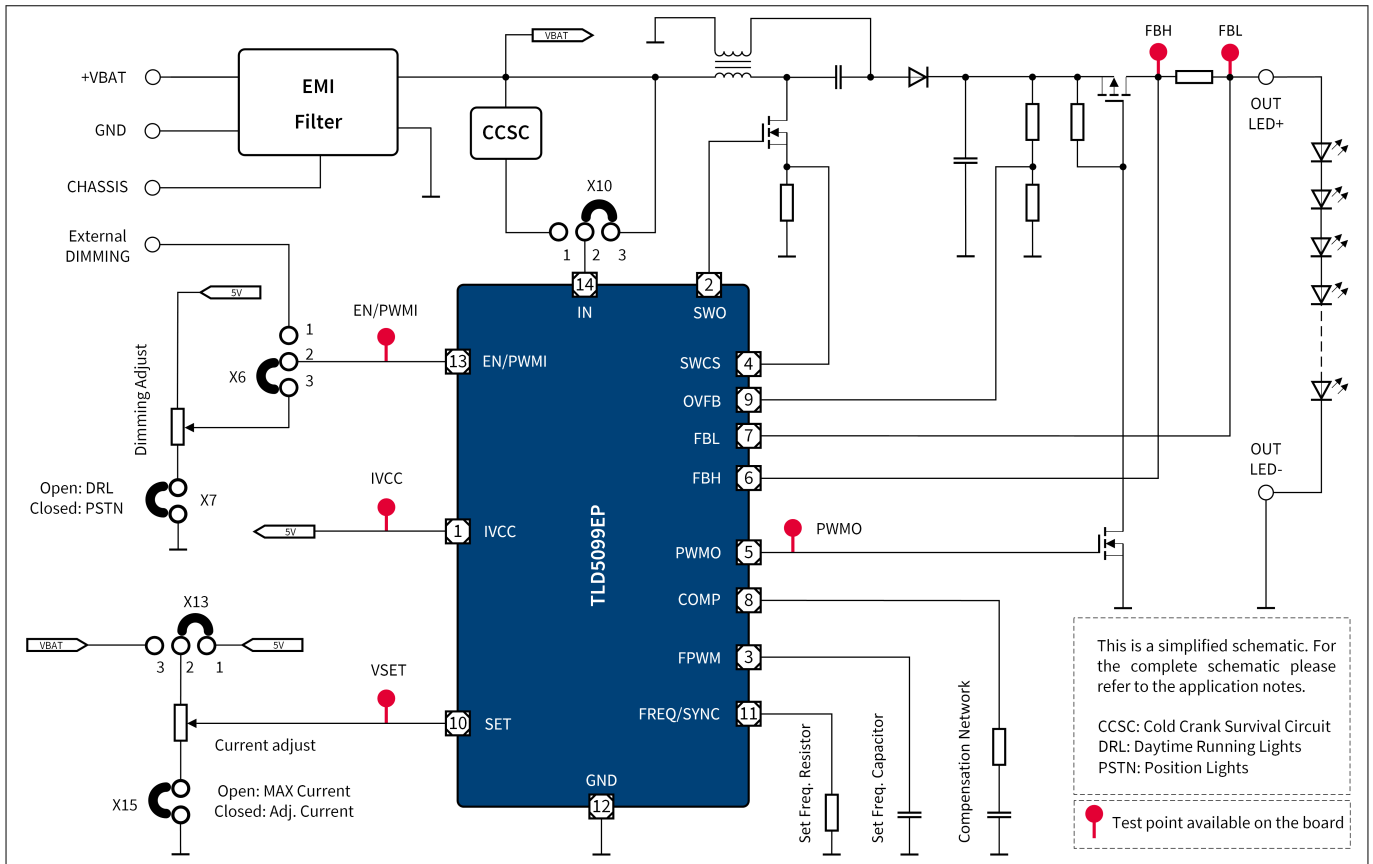

Figure 1 Board picture

**1 Description**



**Figure 2** Simplified schematic

**Table 1** Performance summary

Parameter	Conditions	Value
Input supply voltage	Jumper X10 in position 2-3 (CCSC deactivated) Parameter degradation below 6.5 V	8 V to 27 V Down to 6.5 V for less than 2 s
Input supply voltage	Jumper X10 in position 1-2 (CCSC active)	8 V to 27 V Down to 3.0 V for less than 2 s
Output current	Jumper X15 open	1 A
Switching frequency	$V_{IN} = 13.2 \text{ V}$ ; spread spectrum "on"	400 kHz
Efficiency	Measured with 7 white standard LED 3 V @ 1 A output current	> 84%
Output voltage range	Output voltage related to ground	6 V to 23 V
Output overvoltage protection	Output voltage related to ground	28 V

2 Quick start procedure

## 2 Quick start procedure

The default configuration of the board has all additional features disabled. Jumpers are populated as follows:

**Table 2 Jumper population**

Jumper number	Condition	Meaning
X10	Close 2-3	Disable CCSC
X6	Close 2-1	External dimming enabled
X13	Close 2-1	Disable battery dependent current

The default configuration is depicted below:

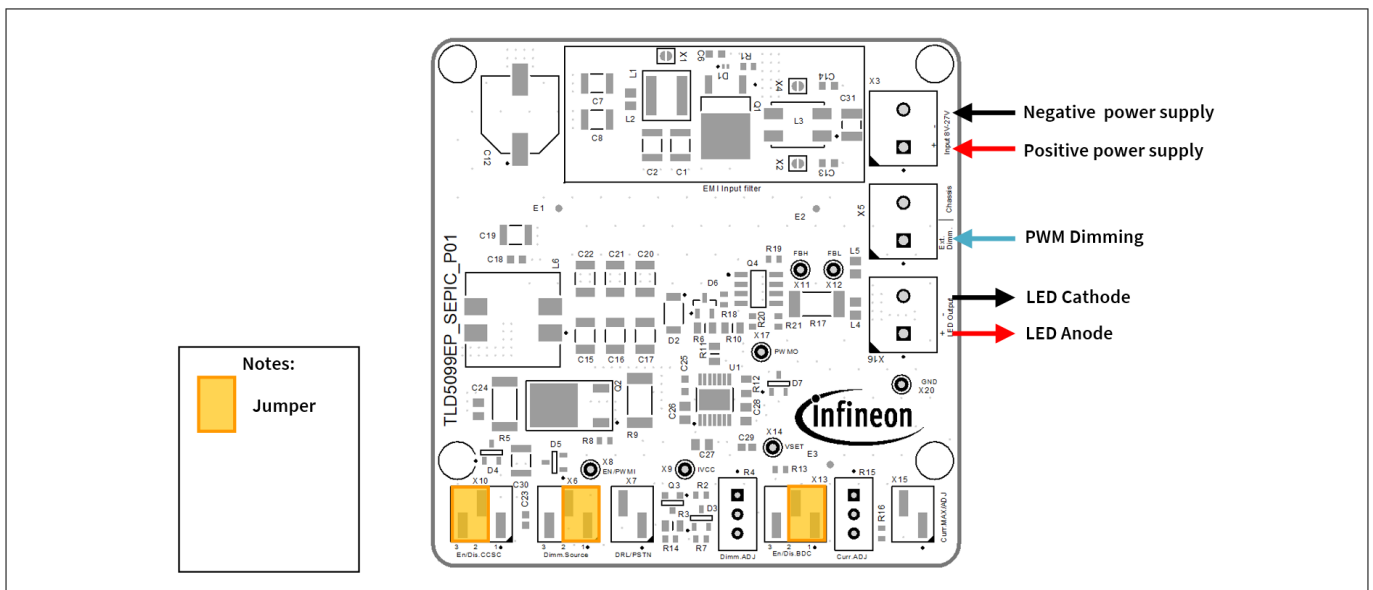

**Figure 3 Default configuration of the board**

In this configuration PWM signal has to be applied as digital signal on X5 (max 45 V), and the output current cannot be adjusted.

3 Current adjustment

### 3 Current adjustment

Output current adjustment can be performed by changing the value of trimmer R15 with a screwdriver, when X13 is closed in position 1-2 and X15 is closed. Output current can vary from 0 to 100% of the maximum output current (in this evaluation board from 0 to 1 A). By removing the X15 jumper, output current will reach its maximum value.

Jumpers are populated as follows:

**Table 3** Jumper population

Jumper number	Condition	Meaning
X10	Close 2-3	Disable CCSC
X6	Close 2-1	External dimming enabled
X13	Close 2-1	Disable battery dependent current
X15	Closed	Adjustable output current enabled

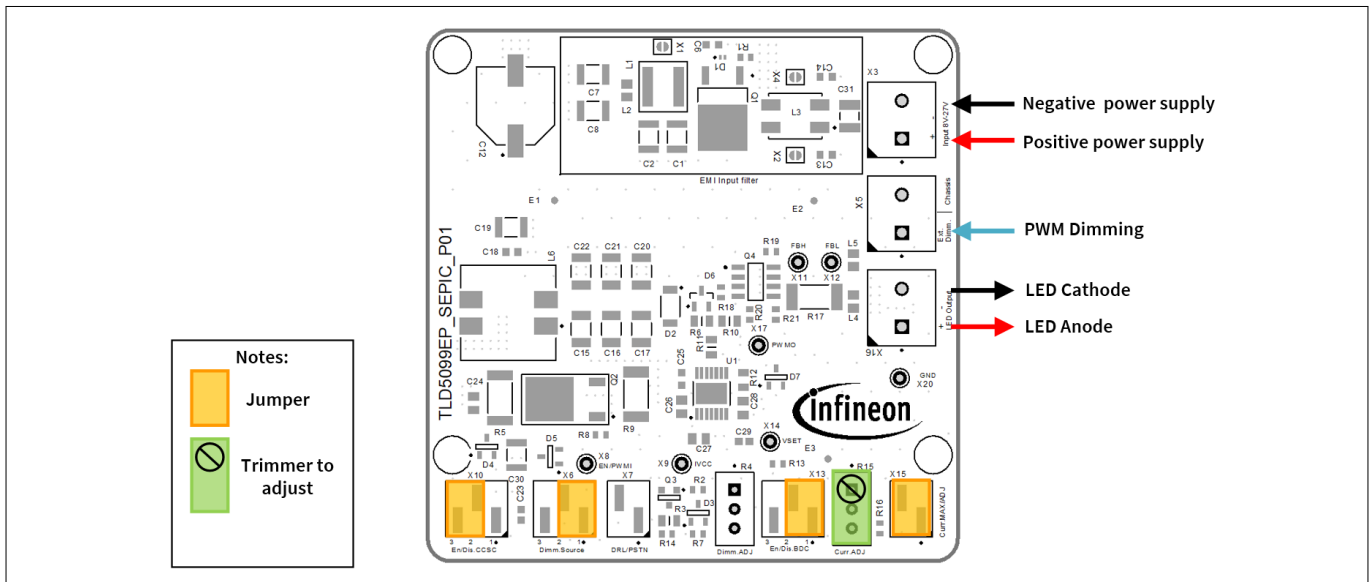

**Figure 4** Current adjustment

4 Power derating (Battery dependent current)

4 Power derating (Battery dependent current)

Power derating acts by reducing  $V_{SET}$  (and thus the output current) when the battery voltage drops below 8 V. It works better when R15 is trimmed to its maximum value, otherwise a different derating profile is applied. If a different derating profile is needed, R14 has to be changed accordingly, in order to have 1.6 V on pin SET when the battery voltage reaches the desired threshold below which the output current must decrease proportionally. A quick formula to calculate R14 is:

$$R14 = (R15 + R16) \cdot \left( \frac{V_{BATT}}{1.6} - 1 \right)$$

where  $R15 = 10\text{ k}\Omega$  and  $R16 = 560\Omega$ .

For example, if the power derating should start when the battery voltage drops under 12 V, R14 must be replaced with a 68 k $\Omega$  0603 resistor (please refer to the TLD5099EP datasheets for more information).

Jumpers are populated as follows:

Table 4 Jumper population

Jumper number	Condition	Meaning
X10	Close 2-3	Disable CCSC
X6	Close 2-1	External dimming enabled
X13	Close 2-3	Enable battery dependent current
X15	Closed	Adjustable output current enabled

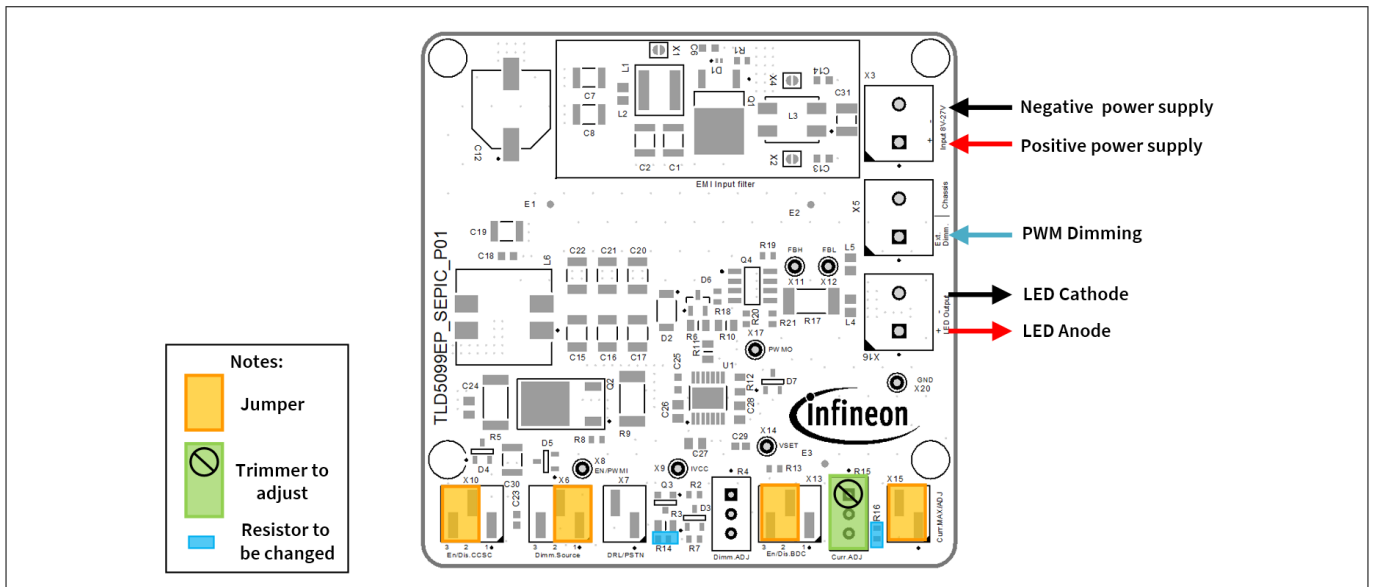

Figure 5 Power derating

5 Embedded PWM engine

## 5 Embedded PWM engine

Embedded PWM engine provides an internal PWM signal without any external dimming signal required. It is enabled when X6 is closed in position 2-3. If X7 is open, EN/PWMI/PWMA pin is biased at 5 V and then the duty cycle is 100%; closing X7, the duty cycle is adjustable through trimmer R4. The PWM frequency is set to 350 Hz; if another PWM frequency is needed, C27 must be changed to a proper value (please refer to the TLD5099EP datasheets for more information).

Jumpers are populated as follows:

**Table 5 Jumper population**

Jumper number	Condition	Meaning
X10	Close 2-3	Disable CCSC
X6	Close 2-3	Internal dimming enabled
X13	Close 2-1	Disable battery dependent current
X7	Closed	Adjustable PWM dimming for position light

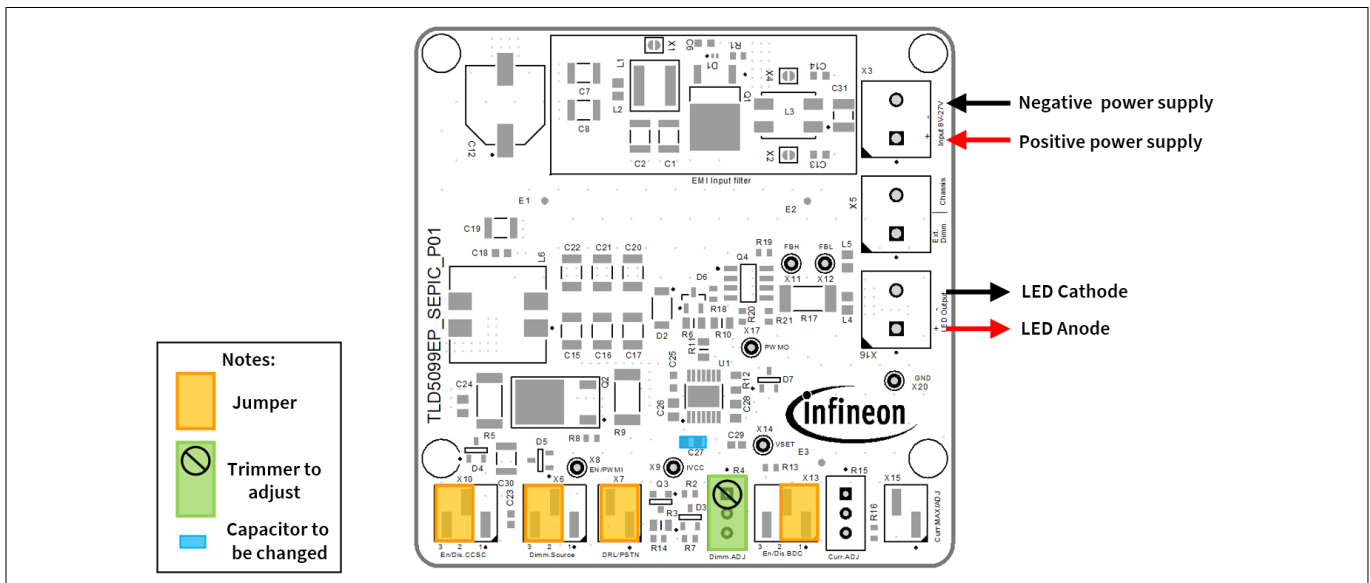

**Figure 6 Embedded PWM engine**

6 Cold crank survival circuit

## 6 Cold crank survival circuit

This feature helps the system to survive LV124 test E11 “severe test pulse”, when input voltage drops below 4.5 V that is the minimum input voltage for the TLD5099EP. This circuit feeds back the device with the output voltage when the input voltage drops. To activate this feature, close X10 in position 1-2. Other settings can be left as preferred.

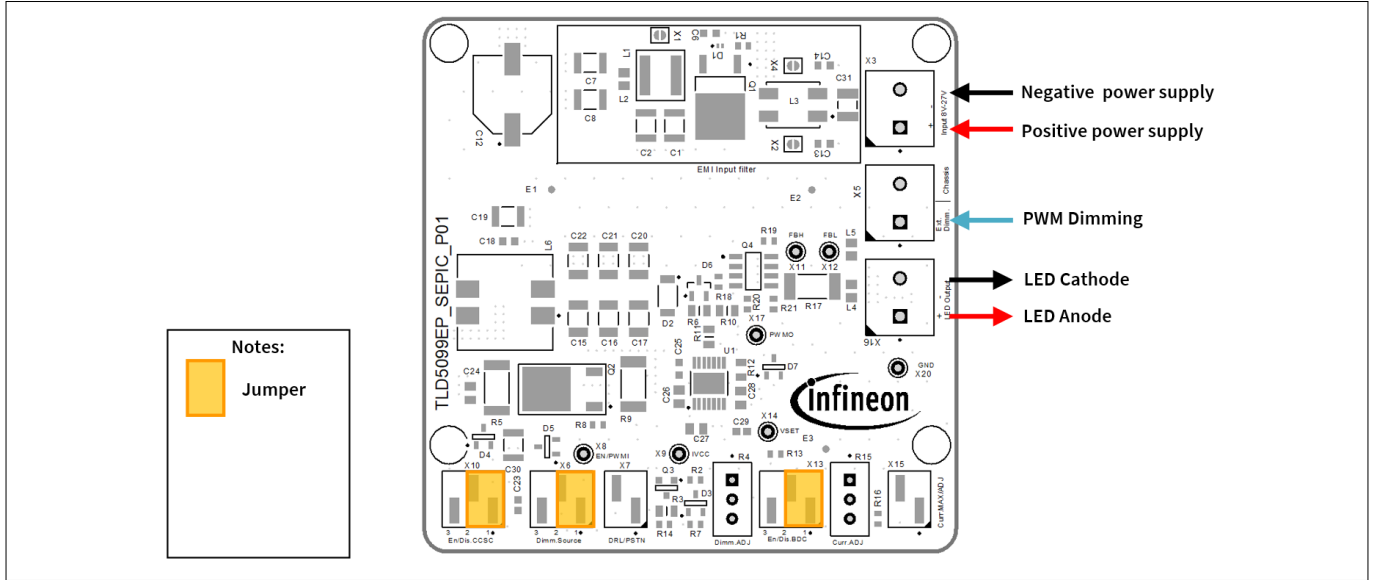

Figure 7 Cold crank survival circuit



7 Schematics

7 Schematics

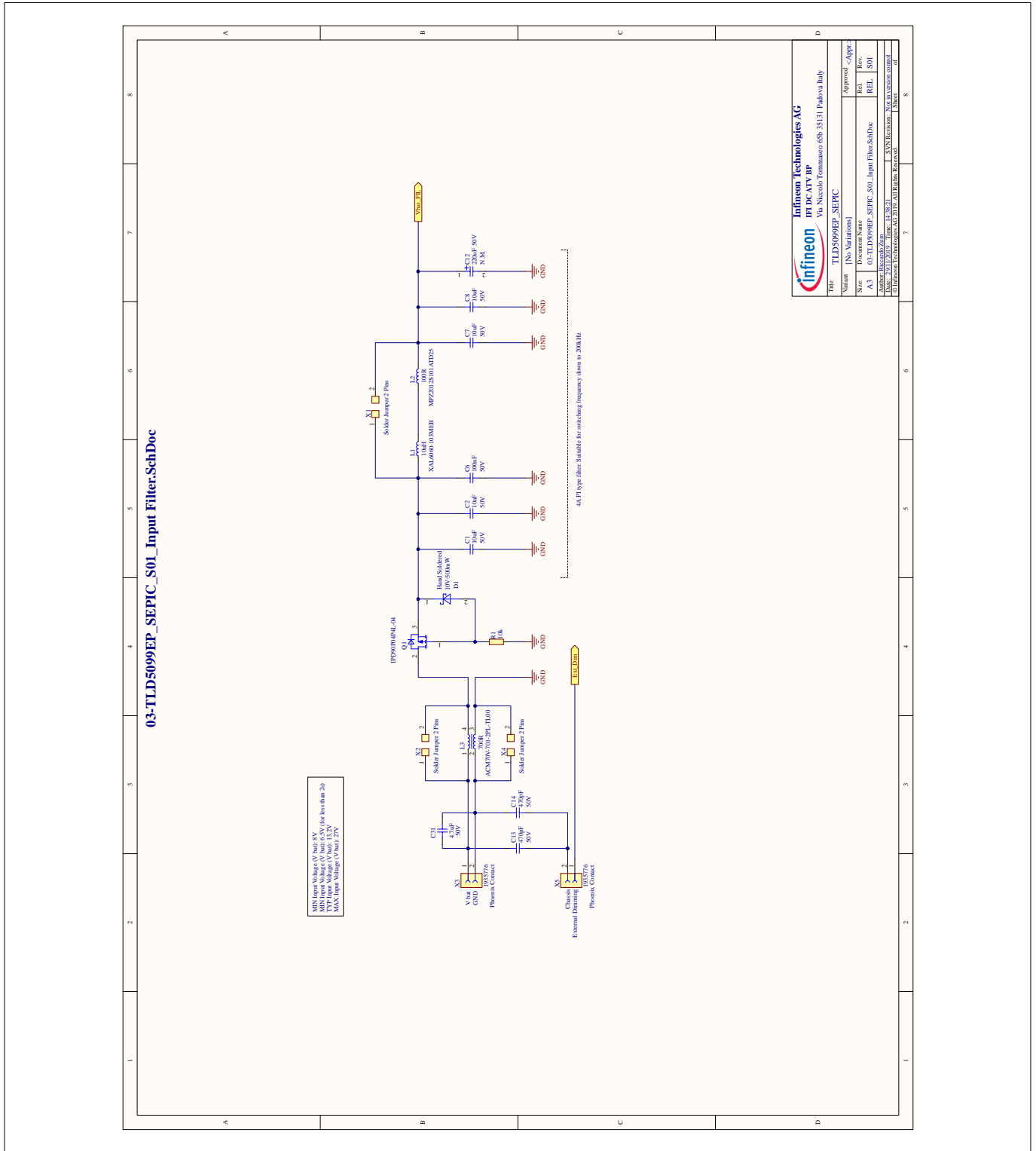

Figure 8 Input filter

7 Schematics

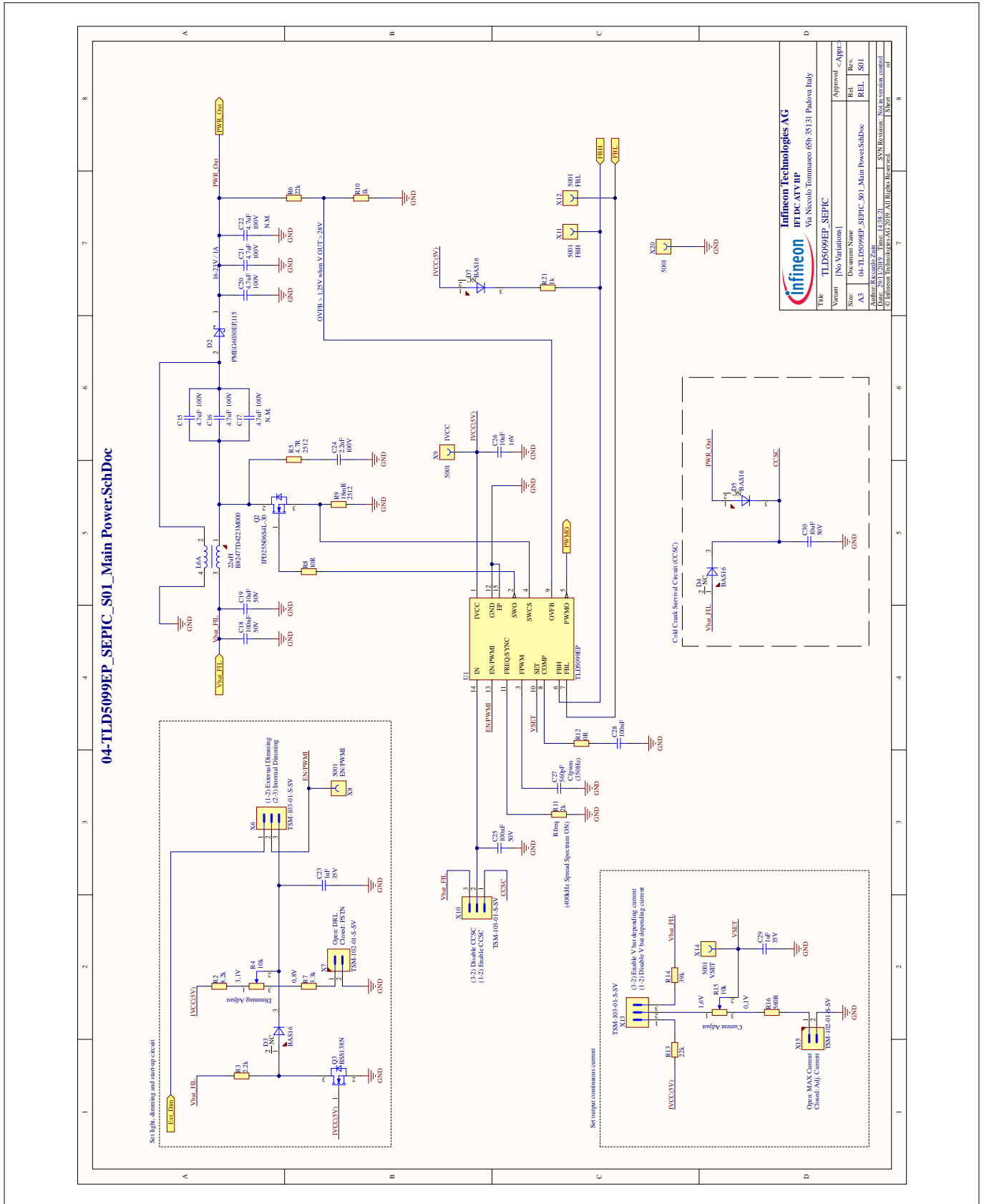

Figure 9 Main power

7 Schematics

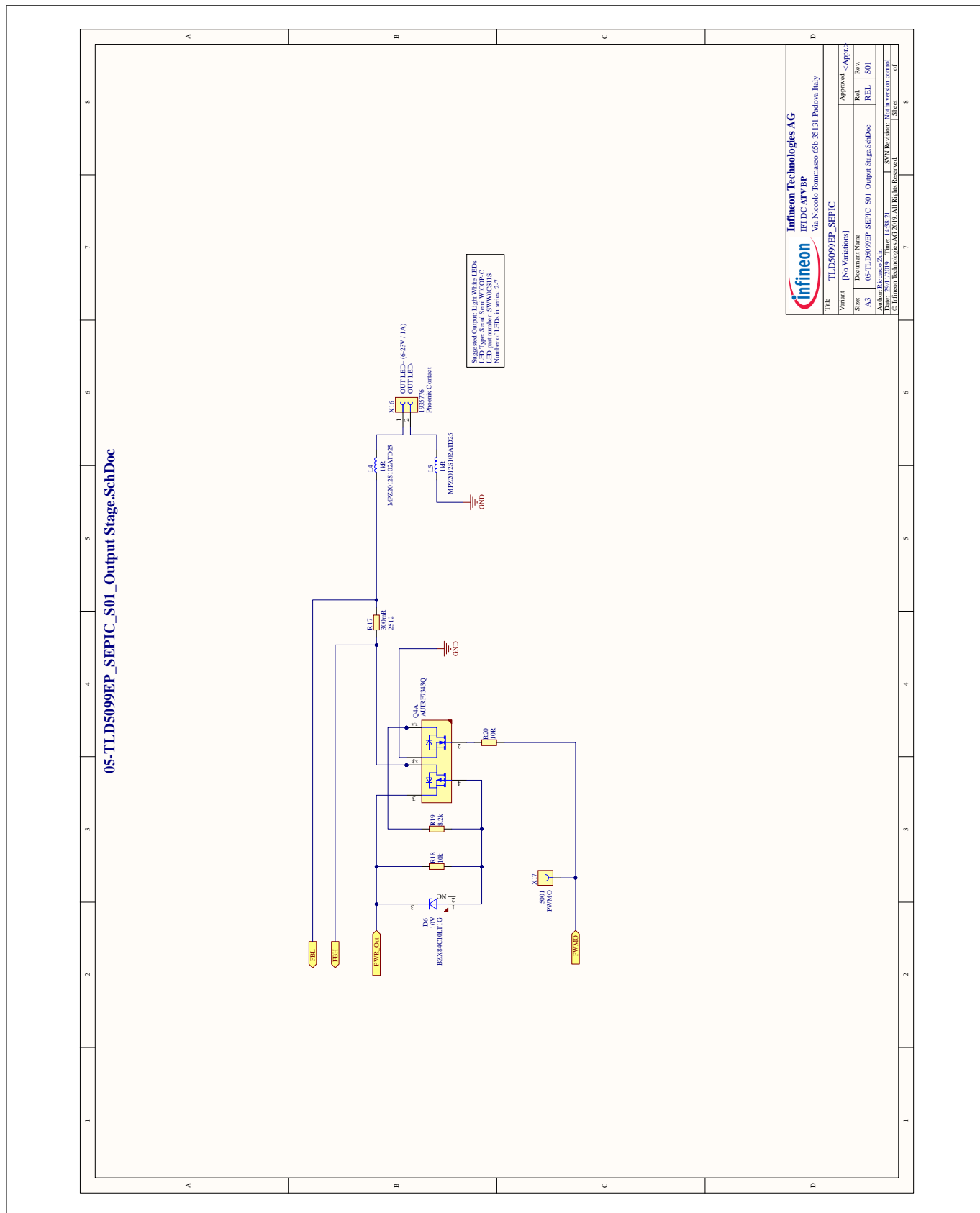

Figure 10 Output stage

8 PCB layout

8 PCB layout

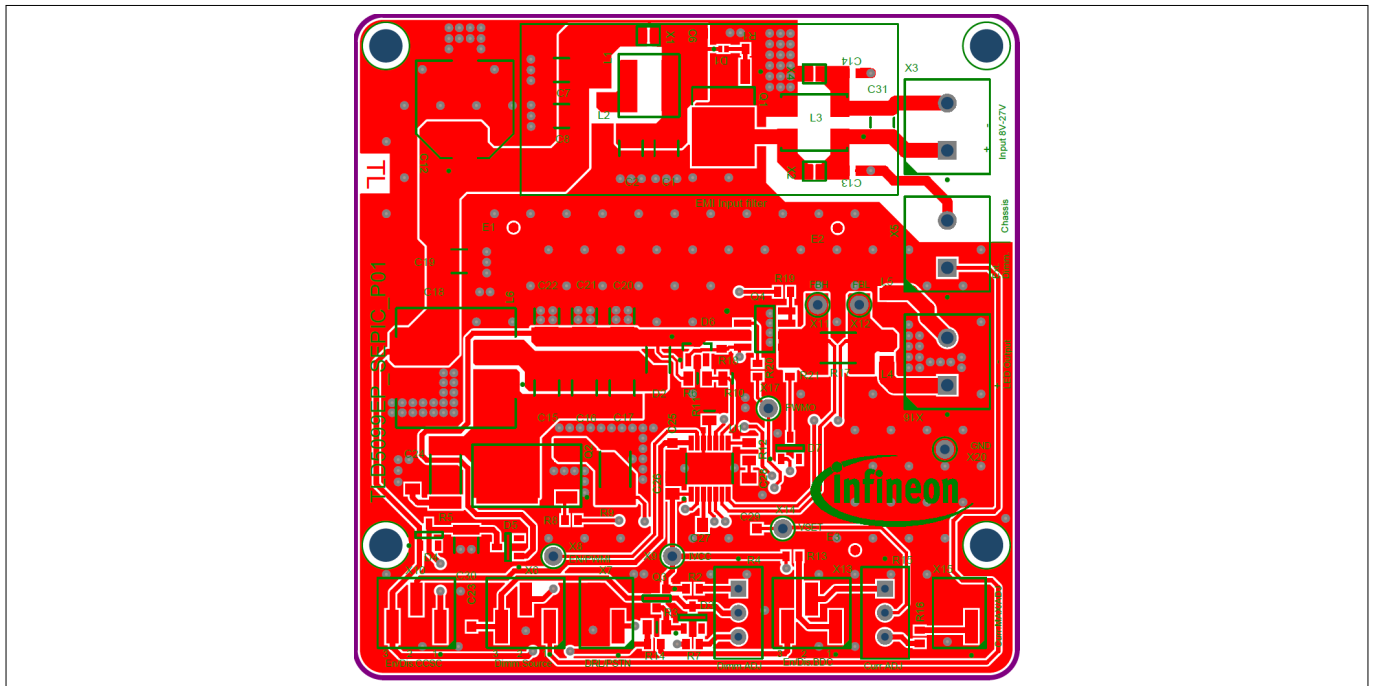

Figure 11 PCB layout top view

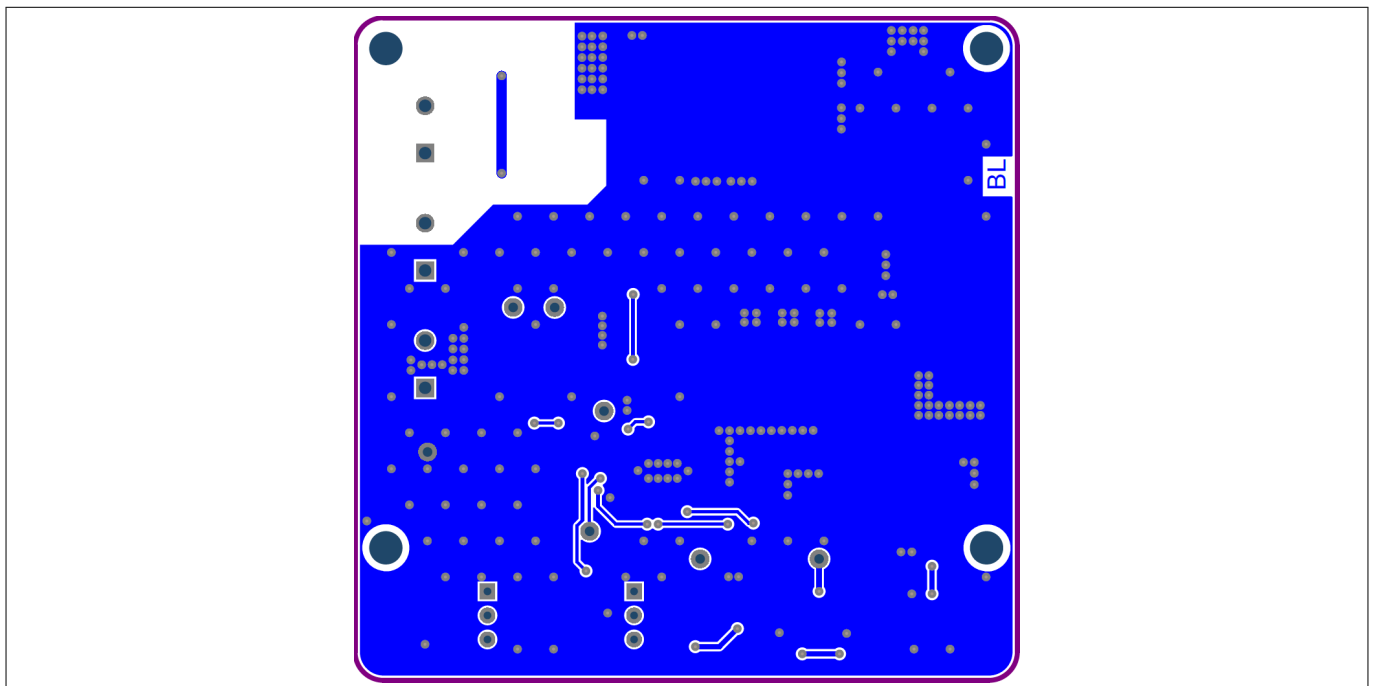

Figure 12 PCB layout bottom view

9 Bill of material

9 Bill of material

Table 6 Bill of material

Designator	Value	Manufacturer	Manufacturer order number
C1, C2, C7, C8, C19, C30	10uF	muRata	GCM32EC71H106KA03
C6, C18, C25	100nF	AVX	06035C104K4Z2A
C12	220uF	Panasonic	EEEFK1H221P
C13, C14	470pF	muRata	GCM1885C1H471JA16
C15, C16, C20, C21	4.7uF	TDK	CGA6M3X7S2A475K200AE
C17, C22	4.7uF	TDK	CGA6M3X7S2A475K200AE
C23, C29	1uF	TDK	CGA3E1X7R1V105K080AC
C24	2.2nF	MuRata	GCM2165C2A222FA16
C26	10uF	TDK	CGA4J1X7S1C106K125AC
C27	560pF	muRata	GCM2165C2A561JA16
C28	100nF	TDK	CGA4J2X7R2A104M125AE
C31	4.7uF	Kemet	C1210C475K5RACAUTO
D1	Zener 10V-500mW		
D2	PMEG6030EP,115	Nexperia	PMEG6030EP,115
D3, D4, D5, D7	BAS16	Infineon Technologies	BAS16
D6	10V	ON Semiconductor	BZX84C10LT1G
L1	10uH	Coilcraft	XAL6060-103MEB
L2	100H	TDK Corporation	MPZ2012S101ATD25
L3		TDK	ACM70V-701-2PL-TL00
L4, L5	1kH	TDK	MPZ2012S102ATD25
L6	22uH	TDK Corporation	B82477D4223M000
Q1	IPD90P04P4L-04	Infineon Technologies	IPD90P04P4L-04
Q2	IPD25N06S4L-30	Infineon Technologies	IPD25N06S4L-30
Q3	BSS138N	Infineon Technologies	BSS138N
Q4	AUIRF7343Q	Infineon Technologies	AUIRF7343Q
R1, R18	10kΩ	Vishay	CRCW060310K0FK
R2, R19	8.2kΩ	Vishay	CRCW06038K20FK
R3	2.2kΩ	Vishay	CRCW08052K20FK
R4, R15	10kΩ	Vishay	T93YA103KT20
R5	4.7Ω	Vishay	CRCW25124R70FK
R6	22kΩ	Vishay	CRCW080522K0FK
R7	3.3kΩ	Vishay	CRCW06033K30FK
R8, R20	10Ω	Vishay	CRCW060310R0FK
R9	18mΩ	Vishay	WSL2512R0180FEA18
R10	1kΩ	Vishay	CRCW08051K00FK

**9 Bill of material**

**Table 6 Bill of material (continued)**

<b>Designator</b>	<b>Value</b>	<b>Manufacturer</b>	<b>Manufacturer order number</b>
R11	2kΩ	Vishay	CRCW08052K00FK
R12	0Ω	Yageo	AC0805JR-070RL
R13	22kΩ	Vishay	CRCW060322K0FK
R14	39kΩ	Vishay	CRCW060339K0FK
R16	560Ω	Vishay	CRCW0603560RFK
R17	300mΩ	Vishay	WSL2512R3000FEA
R21	1kΩ	Vishay	CRCW06031K00FK
U1	TLD5099EP	Infineon Technologies	TLD5099EP
X1, X2, X4	Solder Jumper 2 Pins	Infineon Technologies AG	Solder Jumper 2 Pins
X3, X5, X16	1935776	Phoenix Contact	1935776
X6, X10, X13	TSM-103-01-S-SV	Samtec	TSM-103-01-S-SV
X7, X15	TSM-102-01-S-SV	Samtec	TSM-102-01-S-SV
X8, X9, X11, X12, X14, X17, X20	5001	Keystone	5001

10 Efficiency measurements

10 Efficiency measurements

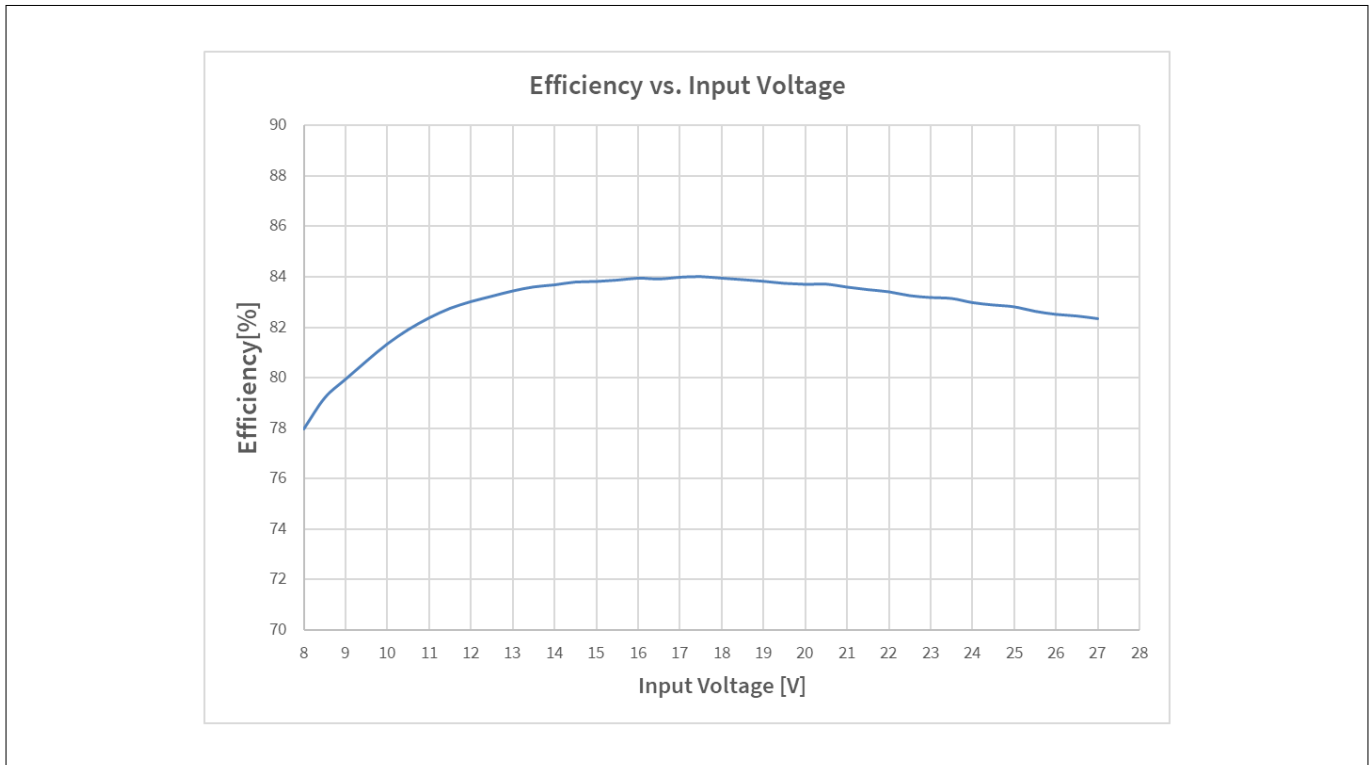

**Figure 13 Efficiency vs. input voltage**

This efficiency performance has been obtained with:

**Table 7 Parameters influencing efficiency**

Output load:	Series of 7 white standard LED with $V_j = 3\text{ V}$ kept cooled with forced air
EMI filter:	Totally bypassed by closing the jumpers X1, X2 and X4
CCSC:	Off (jumper X10 closed on 2-3)
Current adjustment:	Off (jumper X15 left open)
Dimming output:	Off (jumper X7 left open)
Power derating:	Off (jumper X13 closed on 1-2)

Efficiency performances can be increased: refer to [Chapter 11](#).

---

## 11 Maximizing efficiency

### 11 Maximizing efficiency

This evaluation board has been designed to reach a fair compromise between efficiency performance and EMI emissions compliance.

Nevertheless, if the maximum efficiency is needed, the following actions should be considered:

1. Remove the snubber circuit R5, C24 or choose a lower value for the capacitor C24 (for example 1 nF)
2. Bypass the whole EMI filter by bridging the jumpers X1, X2 and X4
3. Bypass the output ferrite beads L4 and L5
4. Replace the main inductor L6 with one that boasts a lower parasitic DC resistance, for example
  - TDK model B82477C6223M603
  - TDK model B82477D6223M603
5. Turn off the CCSC by placing the jumper X10 on position 2-3
6. Bypass the gate resistor R8



## **12 Minimizing EMI emissions**

This evaluation board has been designed to reach a fair compromise between efficiency performance and EMI emissions compliance. Furthermore, this evaluation board can fulfill the class V of the CISPR25 in conducted emissions from 150 kHz to 108 MHz.

Nevertheless, if the minimum EMI emission is required, the following actions should be considered:

- 1.** Choose a higher value for the capacitor C25 (for example 2.7 nF or 3.3 nF)
- 2.** Include the whole EMI filter by removing bridges from the jumpers X1, X2 and X4
- 3.** Increase the gate resistor value R8 with a small value such as 22  $\Omega$
- 4.** With a short piece of wire connect the CHASSIS TERMINAL to the test ground plane as close as possible to where the board is placed

---

13 Revision history

## 13 Revision history

Document version	Date of release	Description of changes
Rev. 1.00	2020-01-29	First release related to evalboard S01_P01.

## Trademarks

All referenced product or service names and trademarks are the property of their respective owners.

**Edition 2020-01-29**

**Published by**

**Infineon Technologies AG**

**81726 Munich, Germany**

**© 2020 Infineon Technologies AG**

**All Rights Reserved.**

**Do you have a question about any aspect of this document?**

**Email: [erratum@infineon.com](mailto:erratum@infineon.com)**

**Document reference**

**IFX-sel1578987058873**

## IMPORTANT NOTICE

The information contained in this application note is given as a hint for the implementation of the product only and shall in no event be regarded as a description or warranty of a certain functionality, condition or quality of the product. Before implementation of the product, the recipient of this application note must verify any function and other technical information given herein in the real application. Infineon Technologies hereby disclaims any and all warranties and liabilities of any kind (including without limitation warranties of non-infringement of intellectual property rights of any third party) with respect to any and all information given in this application note.

The data contained in this document is exclusively intended for technically trained staff. It is the responsibility of customer's technical departments to evaluate the suitability of the product for the intended application and the completeness of the product information given in this document with respect to such application.

## WARNINGS

Due to technical requirements products may contain dangerous substances. For information on the types in question please contact your nearest Infineon Technologies office.

Except as otherwise explicitly approved by Infineon Technologies in a written document signed by authorized representatives of Infineon Technologies, Infineon Technologies' products may not be used in any applications where a failure of the product or any consequences of the use thereof can reasonably be expected to result in personal injury

## X-ON Electronics

Largest Supplier of Electrical and Electronic Components

*Click to view similar products for [Power Management IC Development Tools](#) category:*

*Click to view products by [Infineon](#) manufacturer:*

Other Similar products are found below :

[EVAL-ADM1168LQEBZ](#) [EVB-EP5348UI](#) [MIC23451-AAAYFL EV](#) [MIC5281YMME EV](#) [DA9063-EVAL](#) [ADP122-3.3-EVALZ](#) [ADP130-0.8-EVALZ](#) [ADP130-1.2-EVALZ](#) [ADP130-1.5-EVALZ](#) [ADP130-1.8-EVALZ](#) [ADP1712-3.3-EVALZ](#) [ADP1714-3.3-EVALZ](#) [ADP1715-3.3-EVALZ](#) [ADP1716-2.5-EVALZ](#) [ADP1740-1.5-EVALZ](#) [ADP1752-1.5-EVALZ](#) [ADP1828LC-EVALZ](#) [ADP1870-0.3-EVALZ](#) [ADP1871-0.6-EVALZ](#) [ADP1873-0.6-EVALZ](#) [ADP1874-0.3-EVALZ](#) [ADP1882-1.0-EVALZ](#) [ADP199CB-EVALZ](#) [ADP2102-1.25-EVALZ](#) [ADP2102-1.875EVALZ](#) [ADP2102-1.8-EVALZ](#) [ADP2102-2-EVALZ](#) [ADP2102-3-EVALZ](#) [ADP2102-4-EVALZ](#) [ADP2106-1.8-EVALZ](#) [ADP2147CB-110EVALZ](#) [AS3606-DB](#) [BQ24010EVM](#) [BQ24075TEVM](#) [BQ24155EVM](#) [BQ24157EVM-697](#) [BQ24160EVM-742](#) [BQ24296MEVM-655](#) [BQ25010EVM](#) [BQ27411EVM-G1A](#) [BQ3055EVM](#) [NCV891330PD50GEVB](#) [ISLUSBI2CKIT1Z](#) [LM2744EVAL](#) [LM2854EVAL](#) [LM3658SD-AEV/NOPB](#) [LM3658SDEV/NOPB](#) [LM3691TL-1.8EV/NOPB](#) [LM4510SDEV/NOPB](#) [LM5033SD-EVAL](#)