

# TLD5190

H-Bridge DC/DC Controller  
Infineon® LITIX™ Power



<b>Package</b>	PG-VQFN-48-31	PG-TQFP-48-9
<b>Marking</b>	TLD5190QV	TLD5190QU
<b>Sales Name</b>	TLD5190QV	TLD5190QU

## 1 Overview

### Features

- Single Inductor high power Buck-Boost controller
- Wide LED forward voltage Range (2 V up to 55 V)
- Wide VIN Range (IC 4.5 V to 40 V, Power 4.5 V to 55 V)
- Switching Frequency Range from 200 kHz to 700 kHz
- Maximum Efficiency in every condition (up to 96%)
- Constant Current (LED) and Constant Voltage Regulation
- EMC optimized device: Features an auto Spread Spectrum
- Open Load, Overvoltages, Shorted LED fault and Overtemperature Diagnostic Outputs
- LED and Input current sense with dedicated monitor Outputs
- Advanced protection features for device and load
- Enhanced Dimming features: Analog and PWM dimming
- LED current accuracy +/- 3%
- Available in a small thermally enhanced PG-VQFN-48-31 or PG-TQFP-48-9 package
- Automotive AEC Qualified

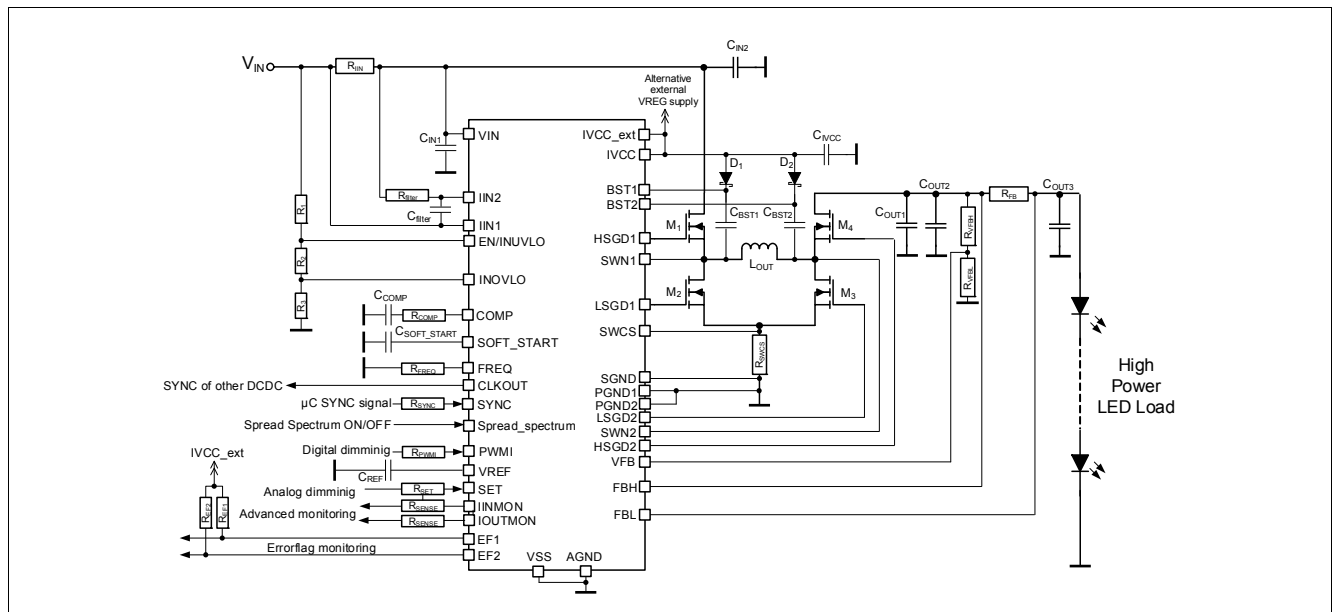
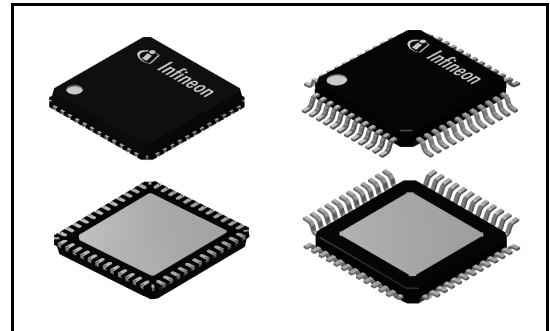

Figure 1 Application Drawing - TLD5190 as current regulator

## Overview

### Description

The TLD5190 is a synchronous MOSFET H-Bridge DC/DC controller with built in protection features. This concept is beneficial for driving high power LEDs with maximum system efficiency and minimum number of external components. The TLD5190 offers both analog and digital (PWM) dimming. The switching frequency is adjustable in the range of 200 kHz to 700 kHz. It can be synchronized to an external clock source. A built in Spread Spectrum switching frequency modulation and the forced continuous current regulation mode improve the overall EMC behavior. Furthermore the current mode regulation scheme provides a stable regulation loop maintained by small external compensation components. The adjustable soft start feature limits the current peak as well as voltage overshoot at start-up. The TLD5190 is suitable for use in the harsh automotive environment.

**Table 1 Product Summary**

Power Stage input voltage range	$V_{POW}$	4.5 V ... 55 V
Device Input supply voltage range	$V_{VIN}$	4.5 V ... 40 V
Maximum output voltage (depending by the application conditions)	$V_{OUT(max)}$	55 V as LED Driver Boost Mode 50 V as LED Driver Buck Mode 50 V as Voltage regulator
Switching Frequency range	$f_{SW}$	200 kHz... 700 kHz
Typical NMOS driver on-state resistance at $T_j = 25^\circ\text{C}$ (Gate Pull Up)	$R_{DS(ON\_PU)}$	2.3 $\Omega$
Typical NMOS driver on-state resistance at $T_j = 25^\circ\text{C}$ (Gate Pull Down)	$R_{DS(ON\_PD)}$	1.2 $\Omega$

### Protective Functions

- Over load protection of external MOSFETs
- Shorted load, open load, output overvoltage protection
- Input overvoltage and undervoltage protection
- Thermal shutdown of device with autorestart behavior
- Electrostatic discharge protection (ESD)

### Diagnostic Functions

- Diagnostic information via Error Flags
- Open load detection in ON-state
- Device Overtemperature shutdown
- Advanced diagnostic functions provide  $I_{LED}$  and  $I_{IN}$  information

### Applications

- Especially designed for driving high power LEDs in automotive applications
- Automotive Exterior Lighting: full LED headlamp assemblies (Low Beam, High Beam, Matrix Beam, Pixel Light)
- General purpose current/voltage controlled DC/DC LED driver

Block Diagram

2 Block Diagram

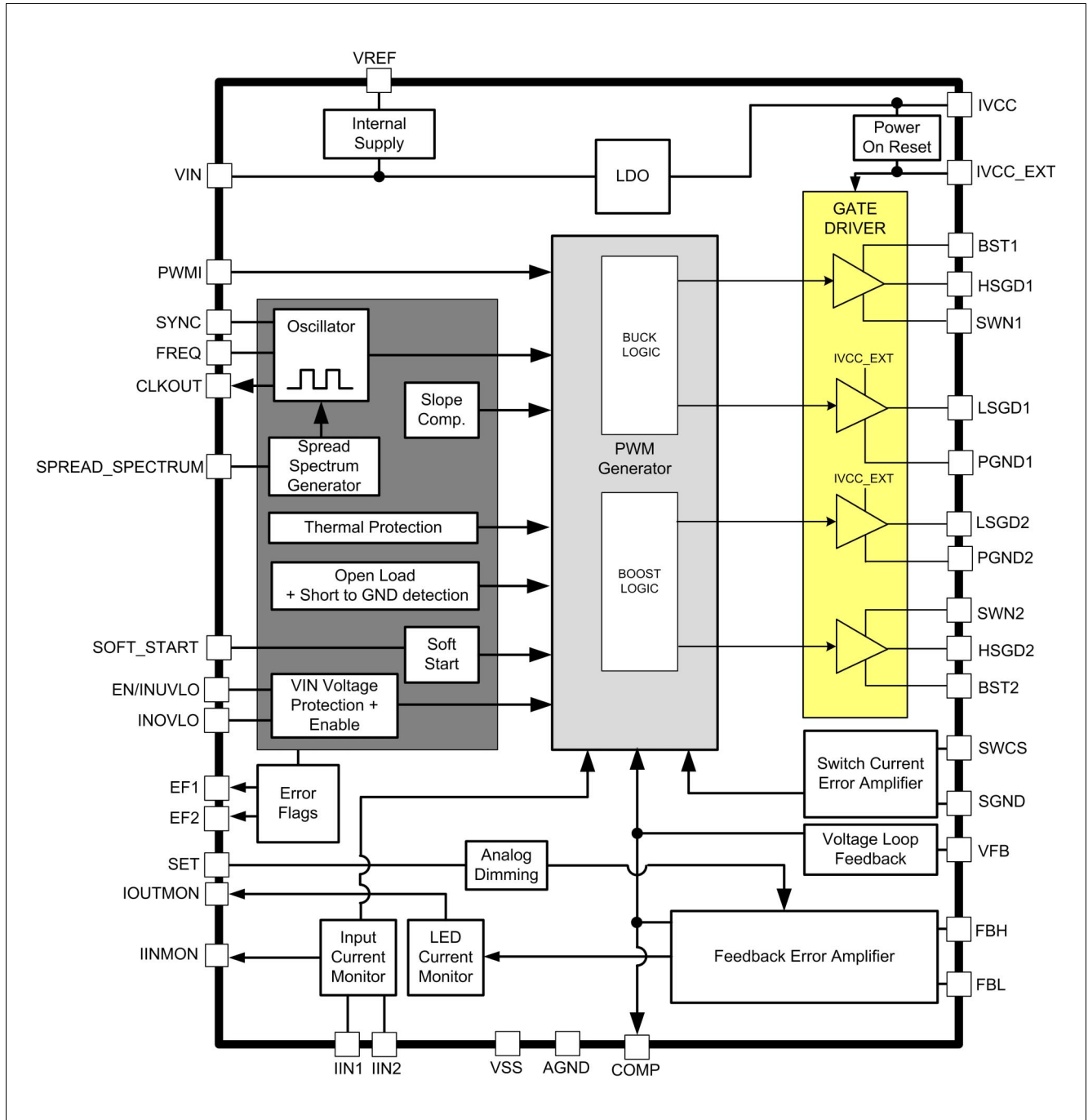

Figure 2 Block Diagram - TLD5190

Pin Configuration

### 3 Pin Configuration

#### 3.1 Pin Assignment

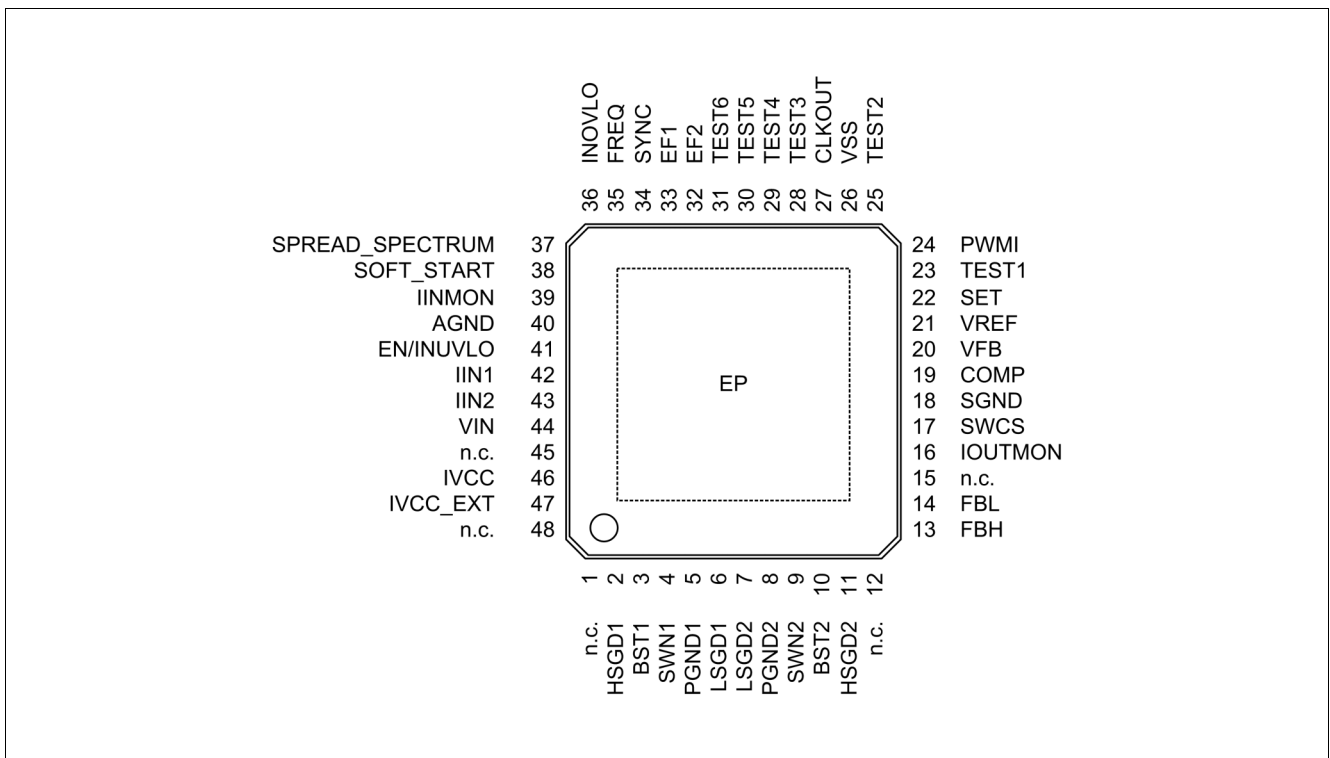

Figure 3 Pin Configuration - TLD5190

Pin Configuration

3.2 Pin Definitions and Functions

Pin	Symbol	I/O <sup>1)</sup>		Function
<b>Power Supply</b>				
1, 12, 15, 45, 48	n.c.	-		<b>Not connected, tie to AGND on the Layout;</b>
44	VIN	-		<b>Power Supply Voltage;</b> Supply for internal biasing.
47	IVCC_EXT	I	PD	<b>External LDO input;</b> Input to alternatively supply internal Gate Drivers via an external LDO. Connect to IVCC pin to use internal LDO to supply gate drivers. Must not be left open.
5, 8	PGND1, 2	-		<b>Power Ground;</b> Ground for power potential. Connect externally close to the chip.
26	VSS	-		<b>Digital GPIO Ground;</b> Ground for GPIO pins.
40	AGND	-		<b>Analog Ground;</b> Ground Reference
-	EP	-		<b>Exposed Pad;</b> Connect to external heatspreading Cu area (e.g. inner GND layer of multilayer PCB with thermal vias).
<b>Gate Driver Stages</b>				
2	HSGD1	O		<b>Highside Gate Driver Output 1;</b> Drives the top n-channel MOSFET with a voltage equal to $V_{IVCC\_EXT}$ superimposed on the switch node voltage SWN1. Connect to gate of external switching MOSFET.
11	HSGD2	O		<b>Highside Gate Driver Output 2;</b> Drives the top n-channel MOSFET with a voltage equal to $V_{IVCC\_EXT}$ superimposed on the switch node voltage SWN2. Connect to gate of external switching MOSFET.
6	LSGD1	O		<b>Lowside Gate Driver Output 1;</b> Drives the lowside n-channel MOSFET between GND and $V_{IVCC\_EXT}$ . Connect to gate of external switching MOSFET.
7	LSGD2	O		<b>Lowside Gate Driver Output 2;</b> Drives the lowside n-channel MOSFET between GND and $V_{IVCC\_EXT}$ . Connect to gate of external switching MOSFET.
4	SWN1	IO		<b>Switch Node 1;</b> SWN1 pin swings from a diode voltage drop below ground up to $V_{IN}$ .
9	SWN2	IO		<b>Switch Node 2;</b> SWN2 pin swings from ground up to a diode voltage drop above $V_{OUT}$ .
46	IVCC	O		<b>Internal LDO output;</b> Used for internal biasing and gate driver supply. Bypass with external capacitor close to the pin. Pin must not be left open.

Pin Configuration

Pin	Symbol	I/O <sup>1)</sup>		Function
<b>Inputs and Outputs</b>				
23	TEST1	-		<b>Test Pin;</b> Used for Infineon end of line test, connect to GND in application.
25	TEST2	-		<b>Test Pin;</b> Used for Infineon end of line test, connect to GND in application.
28	TEST3	-		<b>Test Pin;</b> Used for Infineon end of line test, connect to GND in application.
29	TEST4	-		<b>Test Pin;</b> Used for Infineon end of line test, connect to GND in application.
30	TEST5	-		<b>Test Pin;</b> Used for Infineon end of line test, connect to GND in application.
31	TEST6	-		<b>Test Pin;</b> Used for Infineon end of line test, connect to GND in application.
41	EN/INUVLO	I	PD	<b>Enable/Input Under Voltage Lock Out;</b> Used to put the device in a low current consumption mode, with additional capability to fix an undervoltage threshold via external components. Pin must not be left open.
35	FREQ	I		<b>Frequency Select Input;</b> Connect external resistor to GND to set frequency.
34	SYNC	I	PD	<b>Synchronization Input;</b> Apply external clock signal for synchronization.
24	PWMI	I	PD	<b>Control Input;</b> Digital input 5 V or 3.3 V.
13	FBH	I		<b>Output current Feedback Positive;</b> Non inverting Input (+).
14	FBL	I		<b>Output current Feedback Negative;</b> Inverting Input (-).
3	BST1	IO		<b>Bootstrap capacitor;</b> Used for internal biasing and to drive the Highside Switch HSGD1. Bypass to SWN1 with external capacitor close to the pin. Pin must not be left open.
10	BST2	IO		<b>Bootstrap capacitor;</b> Used for internal biasing and to drive the Highside Switch HSGD2. Bypass to SWN2 with external capacitor close to the pin. Pin must not be left open.
17	SWCS	I		<b>Current Sense Input;</b> Inductor current measurement - Non Inverting Input (+).
18	SGND	I		<b>Current Sense Ground;</b> Inductor current sense - Inverting Input (-). Route as Differential net with SWCS on the Layout.
42	IIN1	I		<b>Input Current Monitor Positive;</b> Non Inverting Input (+), connect to VIN if input current monitor is not needed.
43	IIN2	I		<b>Input Current Monitor Negative;</b> Inverting Input (-), connect to VIN if input current monitor is not needed.

### Pin Configuration

Pin	Symbol	I/O <sup>1)</sup>	Function
19	COMP	O	<b>Compensation Network Pin;</b> Connect R and C network to pin for stability phase margin adjustment.
38	SOFT_START	O	<b>Softstart configuration Pin;</b> Connect a capacitor $C_{SOFT\_START}$ to GND to fix a soft start ramp default time.
36	INOVLO	I	<b>Input Overvoltage Protection Pin;</b> Define an upper voltage threshold and switches OFF the device in case of overvoltages on the VIN supply. Must not be left open.
20	VFB	I	<b>Voltage Loop Feedback Pin;</b> VFB is intended to set output protection functions.
22	SET	I	<b>Analog current sense adjustment Pin;</b> A voltage $V_{SET}$ between 0.2 V and 1.5 V will adjust the $I_{LED}$ or $V_{OUT}$ in a linear relation.
37	SPREAD_SPECTRUM	I PD	<b>Spread Spectrum Pin;</b> This pin is enabling and disabling the SPREAD SPECTRUM function. This feature is beneficial to improve the EMC performance.
39	IINMON	O	<b>Input current monitor output;</b> Monitor pin that produces a voltage that is 20 times the voltage $V_{IN1-IN2}$ . IINMON will be equal 1 V when $V_{IN1}-V_{IN2} = 50$ mV.
16	IOUTMON	O	<b>Output current monitor output;</b> Monitor pin that produces a voltage that is 200 mV + 8 times the voltage $V_{FBH-FBL}$ . IOUTMON will be equal 1.4 V when $V_{FBH-FBL} = 150$ mV.
21	VREF	O PD	<b>Voltage Reference Output Pin;</b> Supplies an accurate 2 V output voltage for standalone analog dimming and LED temperature compensation via external resistors. Bypass with an external 100nF capacitor close to the pin. Pin must not be left open.

### Logic Outputs

27	CLKOUT	O	<b>Clock Output Pin;</b> Switching Oscillator output signal to supply additional SYNC Inputs of other DCDC devices (beneficial for standalone operations without $\mu$ C).
33	EF1	O	<b>Error Flag 1;</b> An open drain output which is pulled to LOW when an output Short to GND or Overtemperature occurs.
32	EF2	O	<b>Error Flag 2;</b> An open drain output which is pulled to LOW when an OPEN load, Overvoltages or Overtemperature occurs.

1) O: Output, I: Input,  
PD: pull-down circuit integrated,  
PU: pull-up circuit integrated

## 4 General Product Characteristics

### 4.1 Absolute Maximum Ratings

**Table 2 Absolute Maximum Ratings<sup>1)</sup>**  
 $T_J = -40^{\circ}\text{C}$  to  $+150^{\circ}\text{C}$ ; all voltages with respect to AGND, (unless otherwise specified)

Parameter	Symbol	Values			Unit	Note or Test Condition	Number
		Min.	Typ.	Max.			
<b>Supply Voltages</b>							
VIN Supply Input	$V_{VIN}$	-0.3	-	60	V	-	P_4.1.1
IVCC Internal Linear Voltage Regulator Output voltage	$V_{IVCC}$	-0.3	-	6	V	-	P_4.1.3
IVCC_EXT External Linear Voltage Regulator Input voltage	$V_{IVCC\_EXT}$	-0.3	-	6	V	-	P_4.1.4
VREF Voltage reference output	$V_{REF}$	-0.3	-	3.6	V	-	P_4.1.5
<b>Gate Driver Stages</b>							
LSGD1,2 - PGND1,2 Lowside Gatedriver voltage	$V_{LSGD1,2-}$ PGND1,2	-0.3	-	5.5	V	-	P_4.1.54
HSGD1,2 - SWN1,2 Highside Gatedriver voltage	$V_{HSGD1,2-}$ SWN1,2	-0.3	-	5.5	V	-	P_4.1.55
SWN1, SWN2 switching node voltage	$V_{SWN1,2}$	-1	-	60	V	-	P_4.1.6
(BST1-SWN1), (BST2-SWN2) Bootstrap voltage	$V_{BST1,2-}$ SWN1,2	-0.3	-	6	V	-	P_4.1.7
BST1, BST2 Bootstrap voltage related to GND	$V_{BST1,2}$	-0.3	-	65	V	-	P_4.1.8
SWCS Switch Current Sense Input voltage	$V_{SWCS}$	-0.3	-	0.3	V	-	P_4.1.9
SGND Switch Current Sense GND voltage	$V_{SGND}$	-0.3	-	0.3	V	-	P_4.1.10
SWCS-SGND Switch Current Sense differential voltage	$V_{SWCS-}$ SGND	-0.5	-	0.5	V	-	P_4.1.11
PGND1,2 Power GND voltage	$V_{PGND1,2}$	-0.3	-	0.3	V	-	P_4.1.28
<b>High voltage Pins</b>							
IIN1, IIN2 Input Current monitor voltage	$V_{IIN1,2}$	-0.3	-	60	V	-	P_4.1.12



General Product Characteristics

**Table 2 Absolute Maximum Ratings<sup>1)</sup> (cont'd)**  
 $T_J = -40^{\circ}\text{C}$  to  $+150^{\circ}\text{C}$ ; all voltages with respect to AGND, (unless otherwise specified)

Parameter	Symbol	Values			Unit	Note or Test Condition	Number
		Min.	Typ.	Max.			
IIN1-IIN2 Input Current monitor differential voltage	$V_{IIN1-IIN2}$	-0.5	-	0.5	V	-	P_4.1.13
FBH, FBL Feedback Error Amplifier voltage	$V_{FBH, FBL}$	-0.3	-	60	V	-	P_4.1.14
FBH-FBL Feedback Error Amplifier differential voltage	$V_{FBH-FBL}$	-0.5	-	0.5	V	-	P_4.1.15
EN/INUVLO Device enable/input undervoltage lockout	$V_{EN/INUVLO}$	-0.3	-	60	V	-	P_4.1.16

**Digital (I/O) Pins**

PWMI Digital Input voltage	$V_{PWMI}$	-0.3	-	5.5	V	-	P_4.1.17
SYNC Synchronization Input voltage	$V_{SYNC}$	-0.3	-	5.5	V	-	P_4.1.22
CLKOUT Clock Output voltage	$V_{CLKOUT}$	-0.3	-	5.5	V	-	P_4.1.23
SPREAD_SPECTRUM Spread Spectrum Input voltage	$V_{SPREAD\_SPECTRUM}$	-0.3	-	5.5	V	-	P_4.1.24

**Analog Pins**

VFB Loop Input voltage	$V_{VFB}$	-0.3	-	5.5	V	-	P_4.1.25
INOVLO Input overvoltage lockout	$V_{INOVLO}$	-0.3	-	5.5	V	-	P_4.1.26
EF1, 2 Error Flags output voltage	$V_{EF1,2}$	-0.3	-	5.5	V	-	P_4.1.27
SET Analog dimming Input voltage	$V_{SET}$	-0.3	-	5.5	V	-	P_4.1.29
COMP Compensation Input voltage	$V_{COMP}$	-0.3	-	3.6	V	-	P_4.1.30
SOFT_START Softstart Voltage	$V_{SOFT\_START}$	-0.3	-	3.6	V	-	P_4.1.31
FREQ Voltage at frequency selection pin	$V_{FREQ}$	-0.3	-	3.6	V	-	P_4.1.32
IINMON Voltage at input monitor pin	$V_{IINMON}$	-0.3	-	3.6	V	-	P_4.1.33
IOUTMON Voltage at output monitor pin	$V_{IOUTMON}$	-0.3	-	5.5	V	-	P_4.1.34

**Temperatures**

General Product Characteristics

**Table 2 Absolute Maximum Ratings<sup>1)</sup> (cont'd)**  
 $T_J = -40^{\circ}\text{C}$  to  $+150^{\circ}\text{C}$ ; all voltages with respect to AGND, (unless otherwise specified)

Parameter	Symbol	Values			Unit	Note or Test Condition	Number
		Min.	Typ.	Max.			
Junction Temperature	$T_J$	-40	–	150	$^{\circ}\text{C}$	–	P_4.1.35
Storage Temperature	$T_{\text{stg}}$	-55	–	150	$^{\circ}\text{C}$	–	P_4.1.36
<b>ESD Susceptibility</b>							
ESD Resistivity of all Pins	$V_{\text{ESD,HBM}}$	-2	–	2	kV	HBM <sup>2)</sup>	P_4.1.37
ESD Resistivity to GND	$V_{\text{ESD,CDM}}$	-500	–	500	V	CDM <sup>3)</sup>	P_4.1.38
ESD Resistivity of corner Pins to GND	$V_{\text{ESD,CDM\_corner}}$	-750	–	750	V	CDM <sup>3)</sup>	P_4.1.39

- 1) Not subject to production test, specified by design.
- 2) ESD susceptibility, HBM according to ANSI/ESDA/JEDEC JS001 (1.5 kV, 100 pF)
- 3) ESD susceptibility, Charged Device Model “CDM” ESDA STM5.3.1 or ANSI/ESD S.5.3.1

*Note: Stresses above the ones listed here may cause permanent damage to the device. Exposure to absolute maximum rating conditions for extended periods may affect device reliability.*

*Integrated protection functions are designed to prevent IC destruction under fault conditions described in the datasheet. Fault conditions are considered as “outside” normal operating range. Protection functions are not designed for continuous repetitive operation.*

## 4.2 Functional Range

**Table 3 Functional Range**

Parameter	Symbol	Values			Unit	Note or Test Condition	Number
		Min.	Typ.	Max.			
Device Extended Supply Voltage Range	$V_{\text{VIN}}$	4.5	–	40	V	1)	P_4.2.1
Device Nominal Supply Voltage Range	$V_{\text{VIN}}$	8	–	36	V	–	P_4.2.2
Power Stage Voltage Range	$V_{\text{POW}}$	4.5	–	55	V	1)	P_4.2.5
Junction Temperature	$T_J$	-40	–	150	$^{\circ}\text{C}$	–	P_4.2.4

- 1) Not subject to production test, specified by design.

*Note: Within the functional range the IC operates as described in the circuit description. The electrical characteristics are specified within the conditions given in the related electrical characteristics table.*

## 4.3 Thermal Resistance

*Note: This thermal data was generated in accordance with JEDEC JESD51 standards. For more information, go to [www.jedec.org](http://www.jedec.org).*

General Product Characteristics

Table 4

Parameter	Symbol	Values			Unit	Note or Test Condition	Number
		Min.	Typ.	Max.			
Junction to Case	$R_{thJC}$	–	0.9	–	K/W	<sup>1) 2)</sup>	P_4.3.1
Junction to Ambient	$R_{thJA}$	–	25	–	K/W	<sup>3)</sup> 2s2p	P_4.3.2

- 1) Not subject to production test, specified by design.
- 2) Specified  $R_{thJC}$  value is simulated at natural convection on a cold plate setup (all pins and the exposed pad are fixed to ambient temperature).  $T_a = 25^\circ\text{C}$ ; The IC is dissipating 1 W.
- 3) Specified  $R_{thJA}$  value is according to JEDEC 2s2p (JESD 51-7) + (JESD 51-5) and JEDEC 1s0p (JESD 51-3) + heatsink area at natural convection on FR4 board; The device was simulated on a 76.2 x 114.3 x 1.5 mm board. The 2s2p board has 2 outer copper layers (2 x 70  $\mu\text{m}$  Cu) and 2 inner copper layers (2 x 35  $\mu\text{m}$  Cu). A thermal via (diameter = 0.3 mm and 25  $\mu\text{m}$  plating) array was applied under the exposed pad and connected the first outer layer (top) to the first inner layer and second outer layer (bottom) of the JEDEC PCB.  $T_a = 25^\circ\text{C}$ ; The IC is dissipating 1 W.

## 5 Power Supply

The TLD5190 is supplied by the following pins:

- VIN (main supply voltage)
- IVCC\_EXT (supply for internal gate driver stages)

The VIN supply provides internal supply voltages for the analog and digital blocks.

IVCC\_EXT is the supply for the low side driver stages. This supply is used also to charge, through external Schottky diodes, the bootstrap capacitors which provide supply voltages to the high side driver stages. If no external voltage is available this pin must be shorted to IVCC, which is the output of an internal 5 V LDO.

The supply pins VIN and IVCC\_EXT have undervoltage detections.

Undervoltage on IVCC\_EXT or IVCC voltages forces a deactivation of the driver stages, thus stopping the switching activity.

Moreover the double function pin EN/INUVLO can be used as an input undervoltage protection by placing a resistor divider from VIN to GND (refer to [Chapter 10.3](#)).

If EN/INUVLO undervoltage is detected, it will turn-off the IVCC voltage regulator and stop switching.

[Figure 4](#) shows a basic concept drawing of the supply domains and interactions among pins VIN and IVCC/IVCC\_EXT.

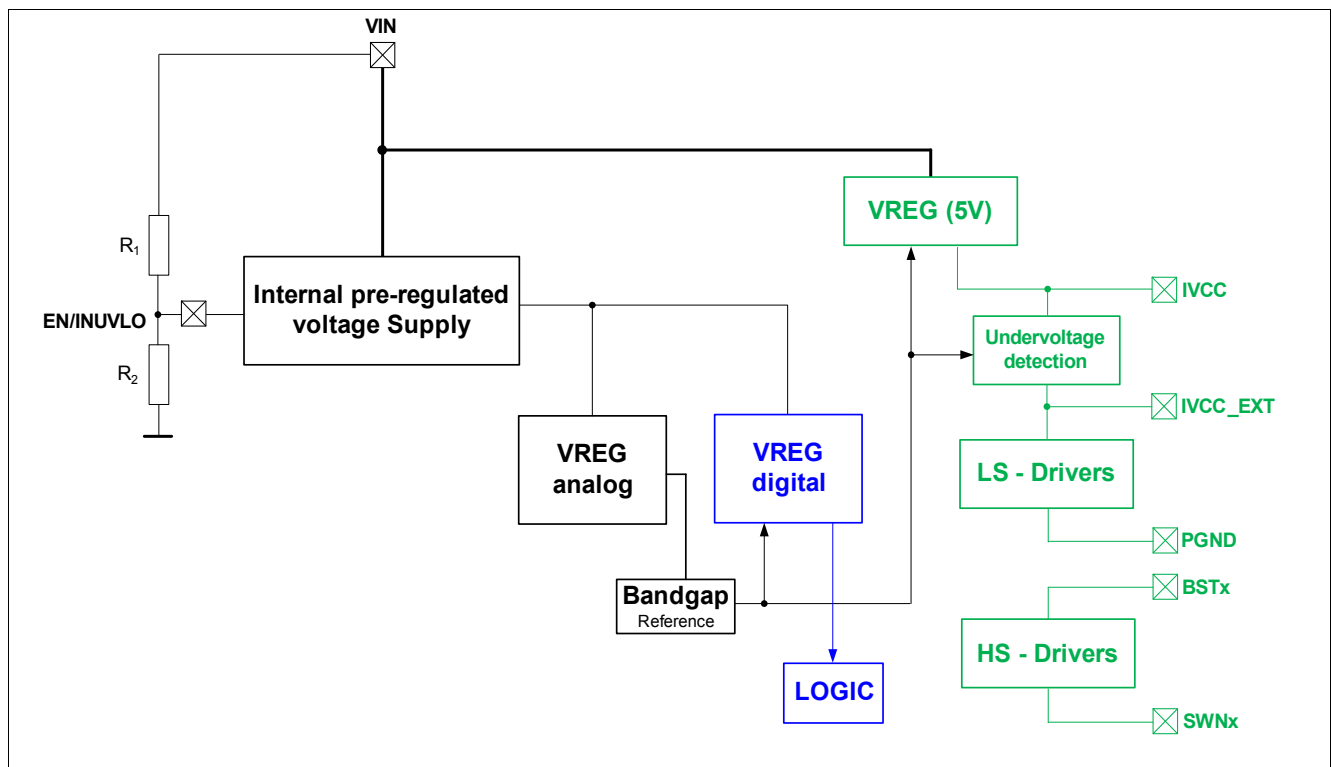

Figure 4 Power Supply Concept Drawing

Power Supply

Usage of EN/INUVLO pin in different applications

The pin EN/INUVLO is a double function pin and can be used to put the device into a low current consumption mode. An undervoltage threshold should be fixed by placing an external resistor divider (A) in order to avoid low voltage operating conditions. This pin can be driven by a  $\mu\text{C}$ -port as shown in (B).

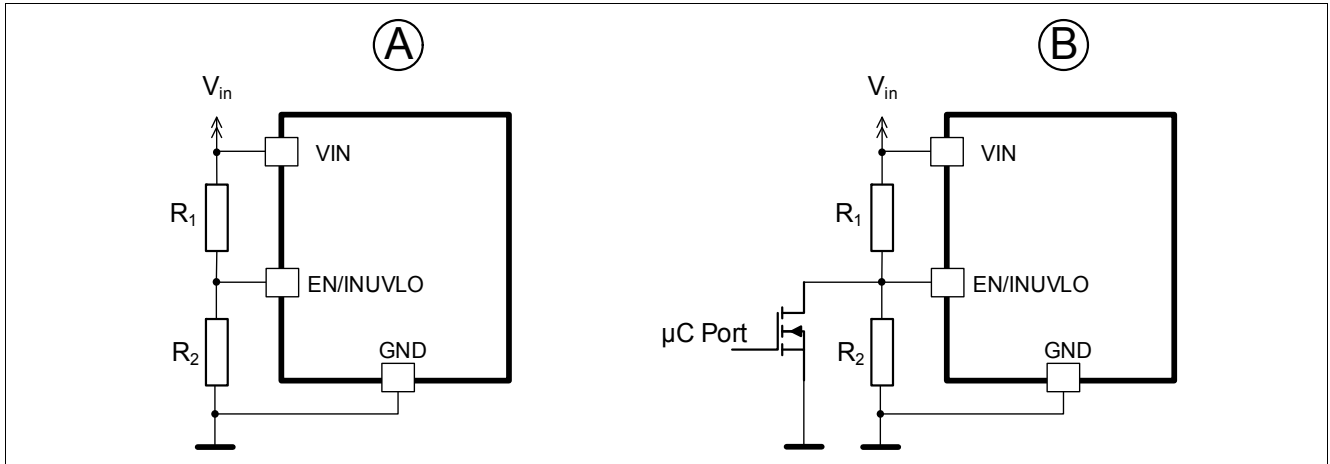

Figure 5 Usage of EN/INUVLO pin in different applications

Power Supply

### 5.1 Different Power States

TLD5190 has the following power states:

- SLEEP state
- IDLE state
- ACTIVE state

The transition between the power states is determined according to these variables after a filter time of max. 3 clock cycles:

- VIN level
- EN/INUVLO level
- IVCC level
- IVCC\_EXT level

The state diagram including the possible transitions is shown in [Figure 6](#).

The Power-up condition is entered when the supply voltage  $V_{VIN}$  exceeds its minimum supply voltage threshold  $V_{VIN(ON)}$ .

#### SLEEP

When the TLD5190 is in the SLEEP state, all outputs are OFF, independently from the supply voltages  $V_{IN}$ , IVCC and IVCC\_EXT. The current consumption is low. Refer to parameter:  $I_{VIN(SLEEP)}$ .

The transition from SLEEP to ACTIVE state requires a specified time:  $t_{ACTIVE}$ .

#### IDLE

In IDLE state the internal voltage regulator is working. Diagnosis functions are not available. The output drivers are switched OFF, independently from the supply voltages  $V_{IN}$ , IVCC and IVCC\_EXT.

#### ACTIVE

In active state the device will start switching activity to provide power at the output only when PWMI = HIGH. To start the Highside gate drivers HSGD1,2 the voltage level  $V_{BST1,2} - V_{SWN1,2}$  needs to be above the threshold  $V_{BST1,2} - V_{SWN1,2\_UVth}$ . In ACTIVE state the device current consumption via  $V_{IN}$  is dependent on the external MOSFET used and the switching frequency  $f_{SW}$ .

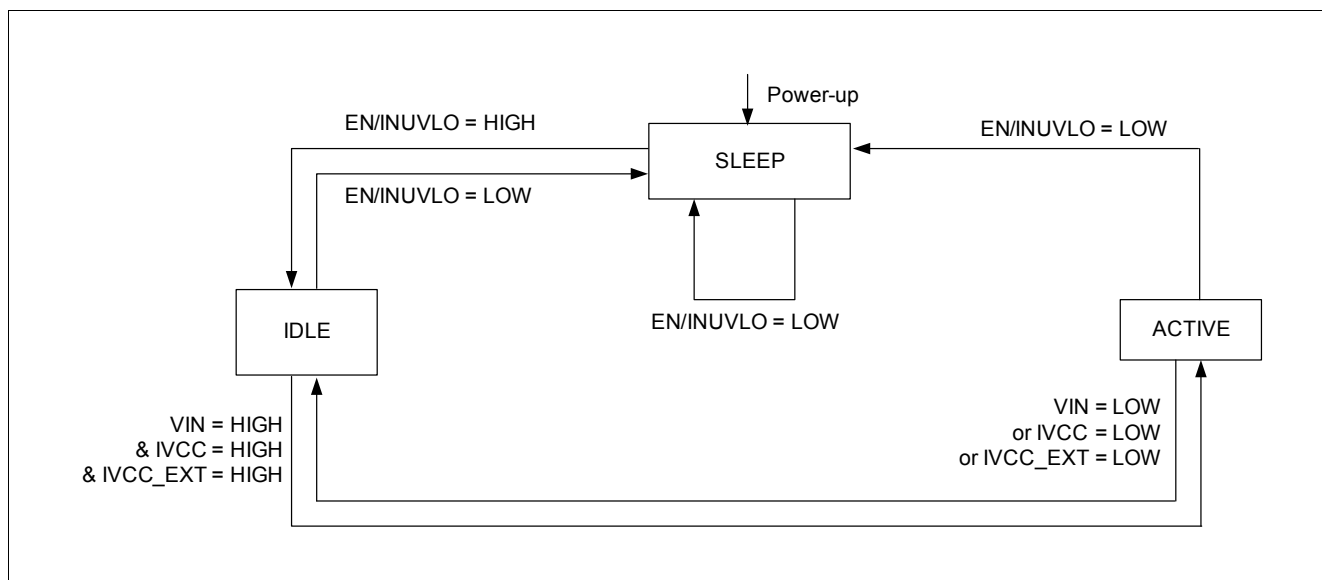

Figure 6 Simplified State Diagram

Power Supply

5.2 Electrical Characteristics

Table 5 EC Power Supply

$V_{IN} = 8\text{ V to }36\text{ V}$ ,  $T_J = -40^\circ\text{C to }+150^\circ\text{C}$ , all voltages with respect to AGND; (unless otherwise specified)

Parameter	Symbol	Values			Unit	Note or Test Condition	Number
		Min.	Typ.	Max.			
<b>Power Supply <math>V_{IN}</math></b>							
Input Voltage Startup	$V_{VIN(ON)}$	–	–	4.7	V	$V_{IN}$ increasing; $V_{EN/INUVLO} = \text{HIGH}$ ; $IVCC = IVCC\_EXT = 10\text{ mA}$ ;	P_5.3.1
Input Undervoltage switch OFF	$V_{VIN(OFF)}$	–	–	4.5	V	$V_{IN}$ decreasing; $V_{EN/INUVLO} = \text{HIGH}$ ; $IVCC = IVCC\_EXT = 10\text{ mA}$ ;	P_5.3.14
Device operating current	$I_{VIN(ACTIVE)}$	–	4.4	6	mA	<sup>1)</sup> ACTIVE mode; CLKOUT freq. 300 KHz; $V_{PWMI} = 0\text{ V}$ ;	P_5.3.2
$V_{IN}$ Sleep mode supply current	$I_{VIN(SLEEP)}$	–	–	1.5	$\mu\text{A}$	$V_{EN/INUVLO} = 0\text{ V}$ ; $V_{IN} = 13.5\text{ V}$ ; $V_{IVCC} = V_{IVCC\_EXT} = 0\text{ V}$ ;	P_5.3.3
<b>EN/INUVLO Pin characteristics</b>							
Input Undervoltage falling Threshold	$V_{EN/INUVLOth}$	1.6	1.75	1.9	V	–	P_5.3.7
EN/INUVLO Rising Hysteresis	$V_{EN/INUVLO(hyst)}$	–	90	–	mV	<sup>1)</sup>	P_5.3.8
EN/INUVLO input Current LOW	$I_{EN/INUVLO(LOW)}$	0.45	0.89	1.34	$\mu\text{A}$	$V_{EN/INUVLO} = 0.8\text{ V}$ ;	P_5.3.9
EN/INUVLO input Current HIGH	$I_{EN/INUVLO(HIGH)}$	1.1	2.2	3.3	$\mu\text{A}$	$V_{EN/INUVLO} = 2\text{ V}$ ;	P_5.3.10
<b>Timings</b>							
SLEEP mode to ACTIVE time	$t_{ACTIVE}$	–	–	0.7	ms	<sup>1)</sup> $V_{IVCC} = V_{IVCC\_EXT}$ ; $C_{IVCC} = 10\text{ }\mu\text{F}$ ; $V_{IN} = 13.5\text{ V}$ ;	P_5.3.11

1) Not subject to production test, specified by design.

## 6 Regulator Description

The TLD5190 includes all of the functions necessary to provide constant current to the output as usually required to drive LEDs. A voltage mode regulation can also be implemented (Refer to [Chapter 6.6](#)).

It is designed to control 4 gate driver outputs in a H-Bridge topology by using only one inductor and 4 external MOSFETs. This topology is able to operate in high power BOOST, BUCK-BOOST and BUCK mode applications with maximum efficiency.

The transition between the different regulation modes is done automatically by the device itself, with respect to the application boundary conditions.

The transition phase between modes is seamless.

### 6.1 Regulator Diagram Description

The TLD5190 includes two analog current control inputs (IIN1, IIN2) to limit the maximum Input current (Block A1 and A7 in [Figure 7](#)).

A second analog current control loop (A5, A6 with compressive gain =  $IFBx_{gm}$ ) connected to the sensing pins FBL, FBH regulates the output current.

The regulator function is implemented by a pulse width modulated (PWM) current mode controller. The error in the output current loop is used to determine the appropriate duty cycle to get a constant output current.

An external compensation network ( $R_{COMP}$ ,  $C_{COMP}$ ) is used to adjust the control loop to various application boundary conditions.

The inductor current for the current mode loop is sensed by the  $R_{SWCS}$  resistor.

$R_{SWCS}$  is used also to limit the maximum external switches / inductor current.

If the Voltage across  $R_{SWCS}$  exceeds its overcurrent threshold ( $V_{SWCS\_buck}$  or  $V_{SWCS\_boost}$  for buck or boost operation respectively) the device reduces the duty cycle in order to bring the switches current below the imposed limit.

The current mode controller has a built-in slope compensation as well to prevent sub-harmonic oscillations.

The control loop logic block (LOGIC) provides a PWM signal to four internal gate drivers. The gate drivers (HSGD1,2 and LSGD1,2) are used to drive external MOSFETs in an H-Bridge setup . Once the soft start expires a forced CCM regulation mode is performed.

The control loop block diagram displayed in [Figure 7](#) shows a typical constant current application. The voltage across  $R_{FB}$  sets the output current.  $R_{IN}$  is used to fix the maximum input current.



Regulator Description

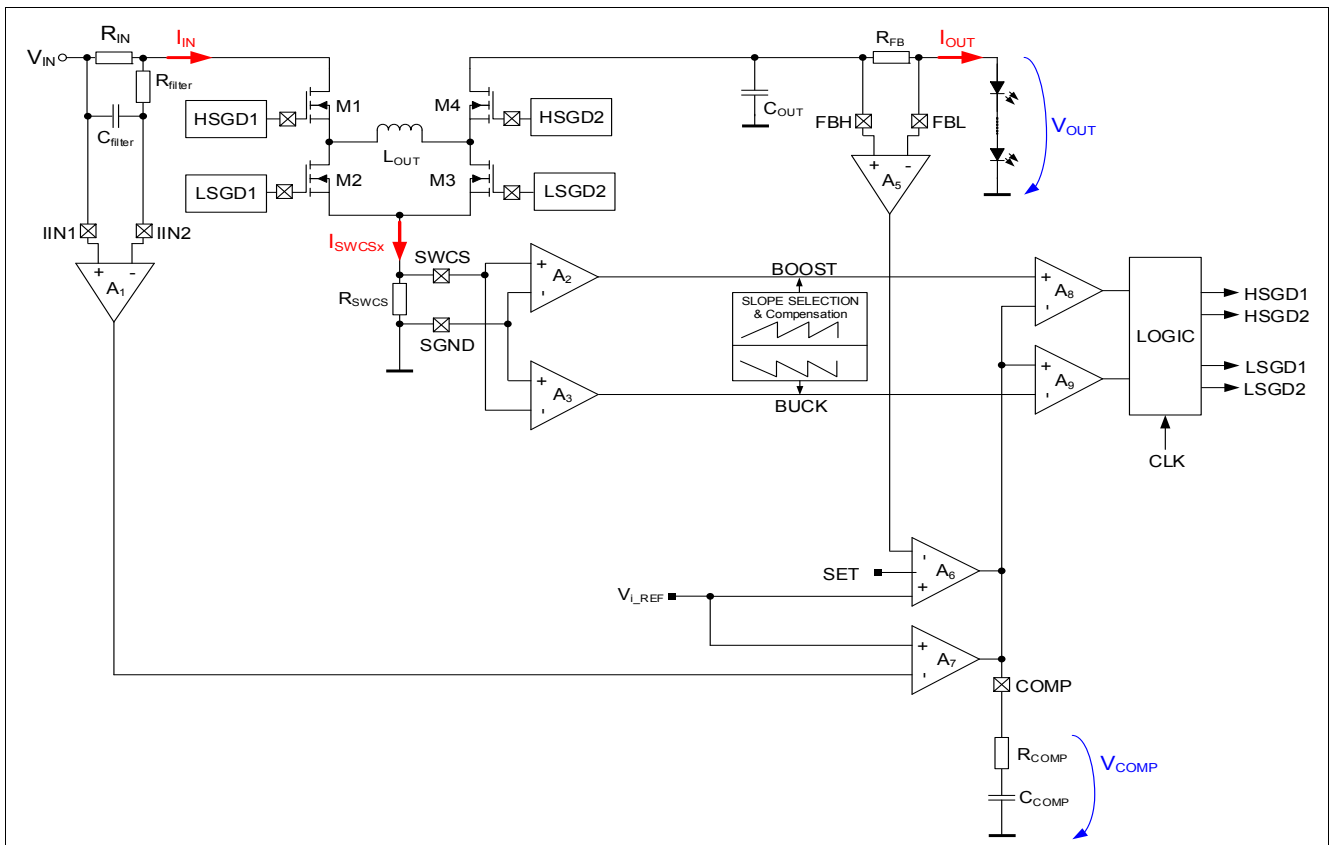

Figure 7 Regulator Block Diagram - TLD5190

## Regulator Description

### 6.2 Adjustable Soft Start Ramp

The soft start routine limits the current through the inductor and the external MOSFET switches during initialization to minimize potential overshoots at the output.

The soft start routine is applied:

- At first turn on (first PWM rise after EN = High)
- After Output Short to GND or Open Load detection
- After Input Overvoltage detection

The soft start rising edge gradually increases the current of the inductor ( $L_{OUT}$ ) over  $t_{SOFT\_START}$  by clamping the COMP voltage. The soft start ramp is defined by a capacitor placed at the SOFT\_START pin.

Selection of the SOFT\_START capacitor ( $C_{SOFT\_START}$ ) can be done according to the approximate formula described in [Equation \(6.1\)](#):

$$t_{SOFT\_START} = \frac{V_{ss\_th\_eff}}{I_{SOFT\_START(PU)}} \cdot C_{SOFT\_START} \quad (6.1)$$

*Note:*  $V_{ss\_th\_eff}$  is the soft start effectiveness threshold, that depends on load condition. Its value is about 0.7 V for the buck mode and 1.4 V for the boost mode

The SOFT START pin is also used to implement a fault mask and wait-before-retry time, on rising and falling edge respectively, see and chapter [Chapter 10.2](#) for details.

If an open load or a short on the output is detected, a pull-down current source  $I_{SOFT\_START\_PD}$  (P\_6.4.20) is activated. Through a pull-up resistor connected from VREF to the SOFT START pin it is possible to source a current higher than  $I_{SOFT\_START\_PD}$ , the TLD5190 will latch OFF until the EN/INUVLO pin is toggled. Without any resistor to VREF the pull-down current decreases until  $V_{SOFT\_START\_RESET}$  (P\_6.4.22) is reached (the pull-up current source turns on again). If the fault condition hasn't been removed until  $V_{SOFT\_START\_LOFF}$  (P\_6.4.21) is reached, the pull-down current source  $I_{SOFT\_START\_PD}$  turns on again initiating a new cycle. This will continue until the fault is removed.

If an input overvoltage is detected the soft start is kept low as long as the overvoltage remains.

At first PWM rise after EN = High, the internal PWM is extended till one of the 2 following condition is reached:

- Until  $V_{SOFT\_START}$  exceeds  $V_{Soft\_Start1,2\_LOFF}$
- Until  $V_{FBH-FBL}$  exceeds  $V_{FBH-FBL\_OL}$

Regulator Description

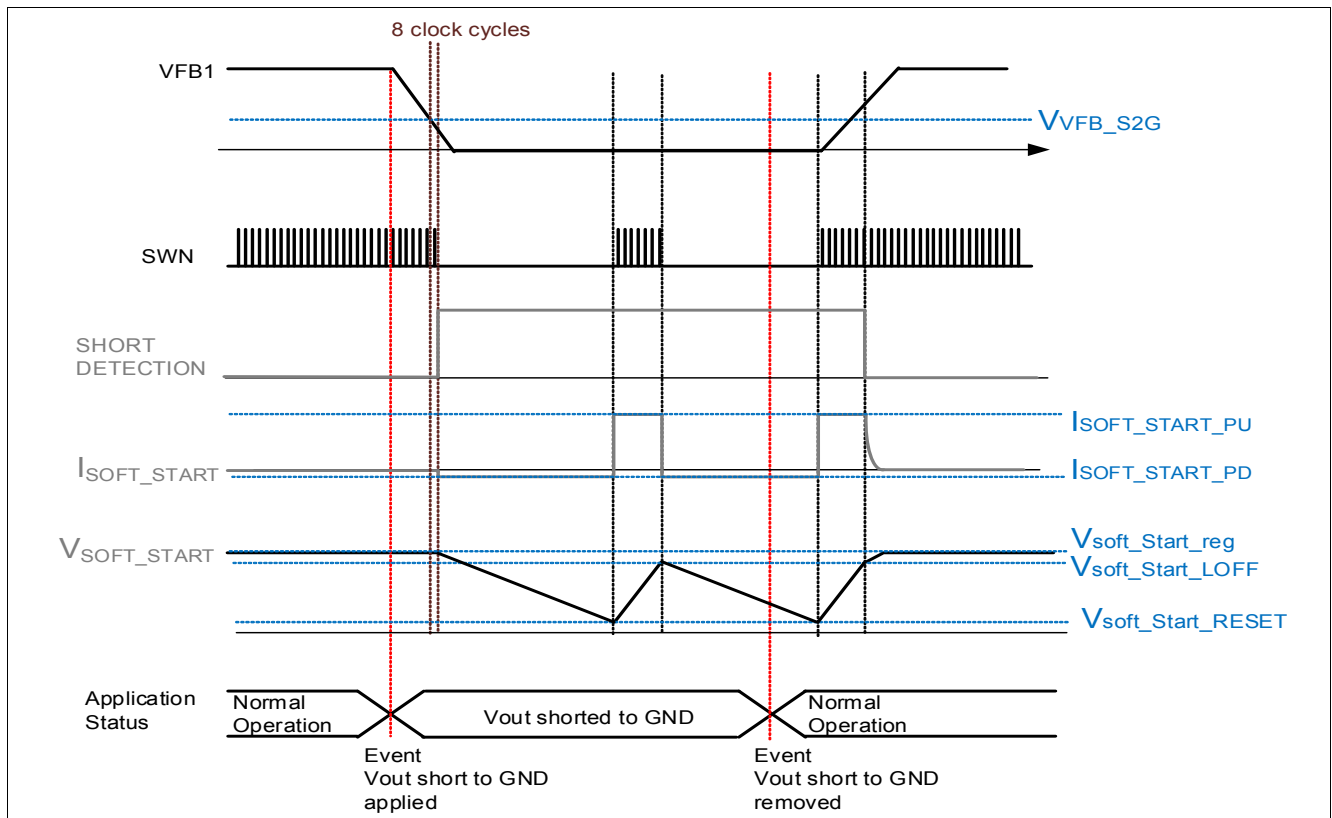

Figure 8 Soft Start timing diagram on a short to ground detected by the VFB pin

### 6.3 Switching Frequency setup

The switching frequency can be set from 200 kHz to 700 kHz by an external resistor connected from the FREQ pin to GND or by supplying a sync signal as specified in chapter [Chapter 11.2](#). Select the switching frequency with an external resistor according to the graph in [Figure 9](#) or the following approximate formulas.

$$f_{SW} [kHz] = 5375 * (R_{FREQ} [k\Omega])^{-0.8} \tag{6.2}$$

$$R_{FREQ} [k\Omega] = 46023 * (f_{SW} [kHz])^{-1.25} \tag{6.3}$$

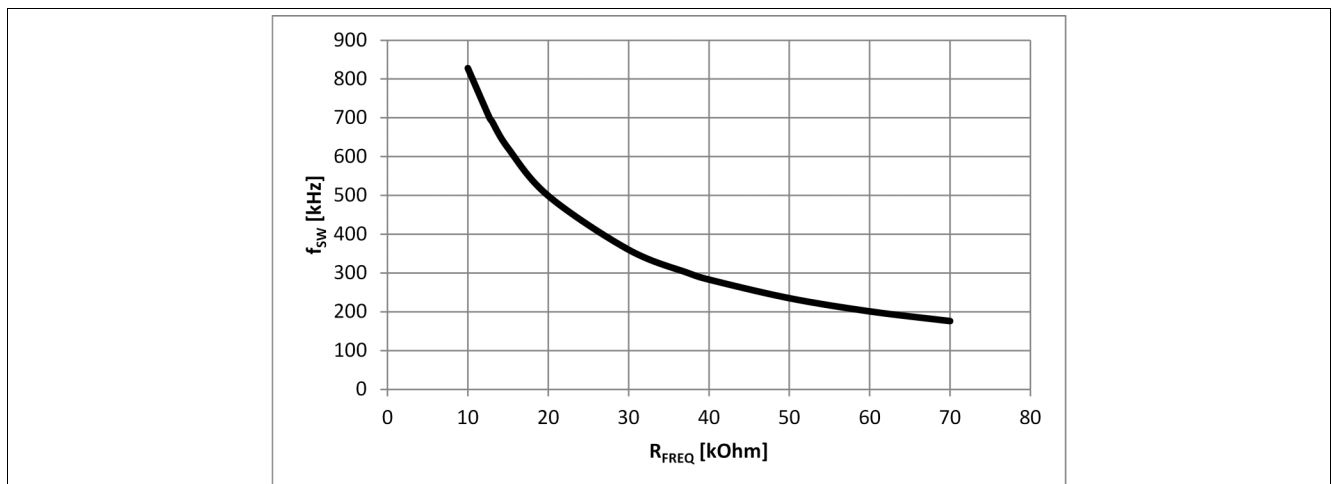

Figure 9 Switching Frequency  $f_{sw}$  versus Frequency Select Resistor to GND  $R_{FREQ}$

Regulator Description

### 6.4 Operation of 4 switches H-Bridge architecture

Inductor  $L_{OUT}$  connects in an H-Bridge configuration with 4 external N channel MOSFETs (M1, M2, M3 & M4)

- Transistor M1 and M3 provides a path between  $V_{IN}$  and ground through  $L_{OUT}$  in one direction (Driven by top and bottom gate drivers HSGD1 and LSGD2)
- Transistor M2 and M4 provides a path between  $V_{OUT}$  and ground through  $L_{OUT}$  in the other direction (Driven by top and bottom gate drivers HSGD2 and LSGD1)
- Nodes SWN1, SWN2, voltage across  $R_{SWCS}$ , input and load currents are also monitored by the TLD5190

	BOOST MODE	BUCK-BOOST MODE	BUCK MODE
M1	ON	PWM	PWM
M2	OFF	PWM	PWM
M3	PWM	PWM	OFF
M4	PWM	PWM	ON

Figure 10 4 switches H-Bridge architecture Transistor Status summary

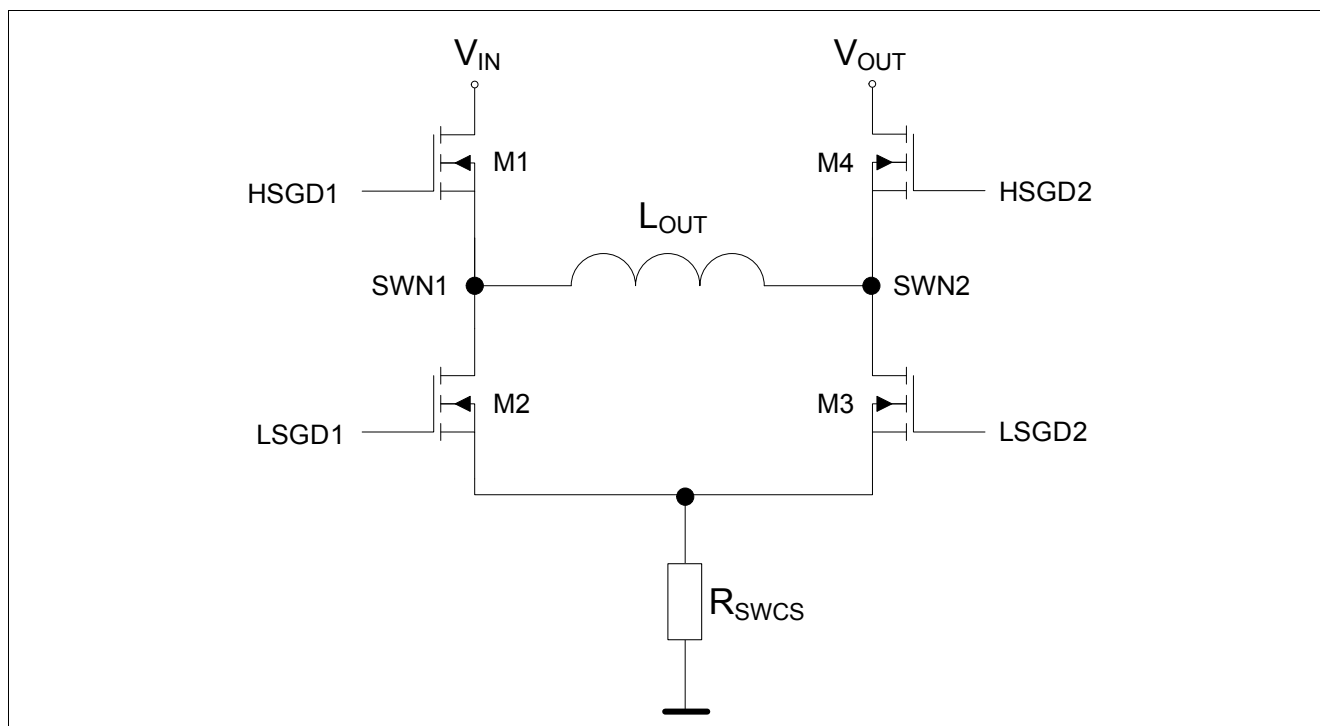

Figure 11 4 switches H-Bridge architecture overview

#### 6.4.1 Boost mode ( $V_{IN} < V_{OUT}$ )

- M1 is always ON, M2 is always OFF
- Every cycle M3 turns ON first and inductor current is sensed (peak current control)
- M3 stays ON until the upper reference threshold is reached across  $R_{SWCS}$  (Energizing)

Regulator Description

- M3 turns OFF, M4 turns ON until the end of the cycle (Recirculation)
- Switches M3 and M4 alternate, behaving like a typical synchronous boost Regulator (see Figure 12)

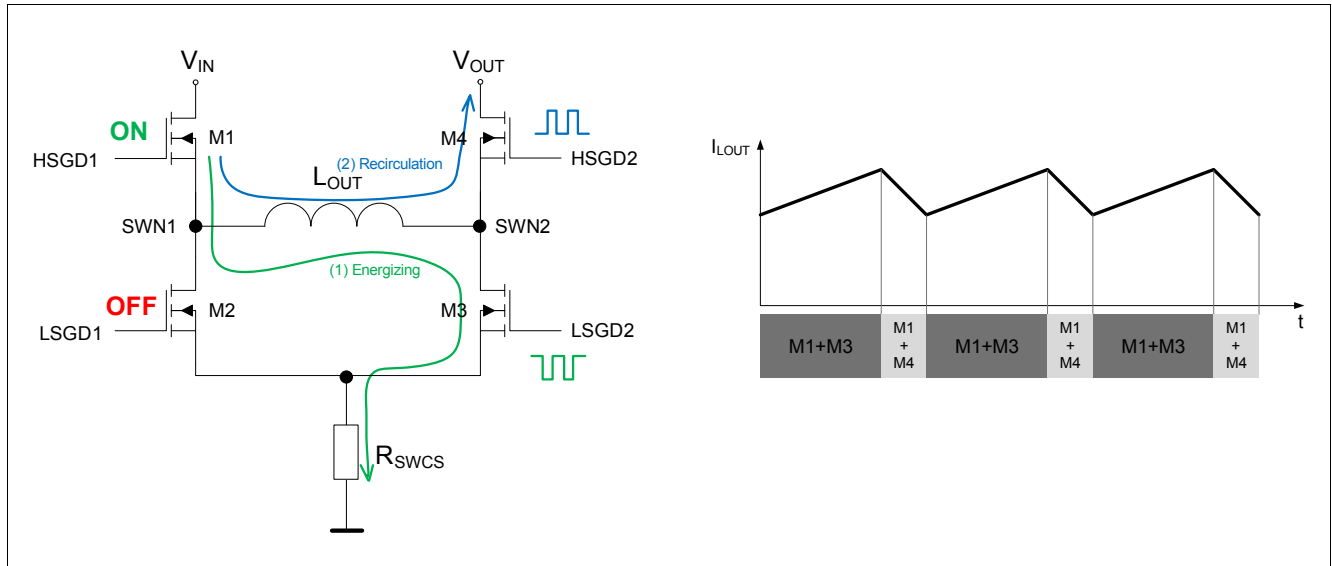

Figure 12 4 switches H-Bridge architecture in BOOST mode

Simplified comparison of 4 switches H-Bridge architecture to traditional asynchronous Boost approach.

- M2 is always OFF in this mode (open)
- M1 is always ON in this mode (closed connection of inductor to  $V_{IN}$ )
- M4 acts as a synchronous diode, with significantly lower conduction power losses ( $I^2 \times R_{DS(ON)}$  vs.  $0.7 V \times I$ )

Note: Diode is source of losses and lower system efficiency!

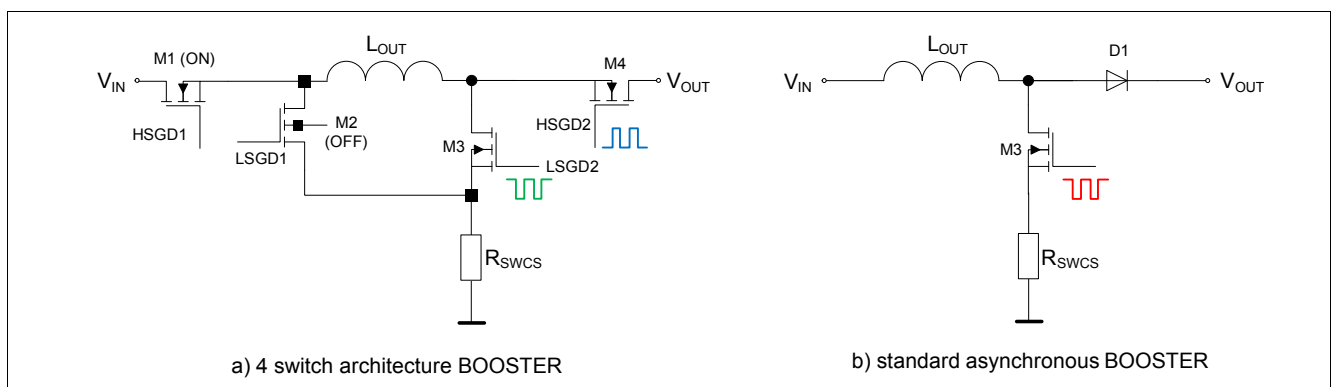

Figure 13 4 switches H-Bridge architecture in BOOST mode compared to standard async Booster

6.4.2 Buck mode ( $V_{IN} > V_{OUT}$ )

- M4 is always ON, M3 is always OFF
- Every cycle M2 turns ON and inductor current is sensed (valley current control)
- M2 stays ON until the lower reference threshold is reached across  $R_{SWCS}$  (Recirculation)

Regulator Description

- M2 turns OFF, M1 turns ON until the end of the cycle (Energizing)
- Switches M1 and M2 alternate, behaving like a typical synchronous BUCK Regulator (see [Figure 14](#))

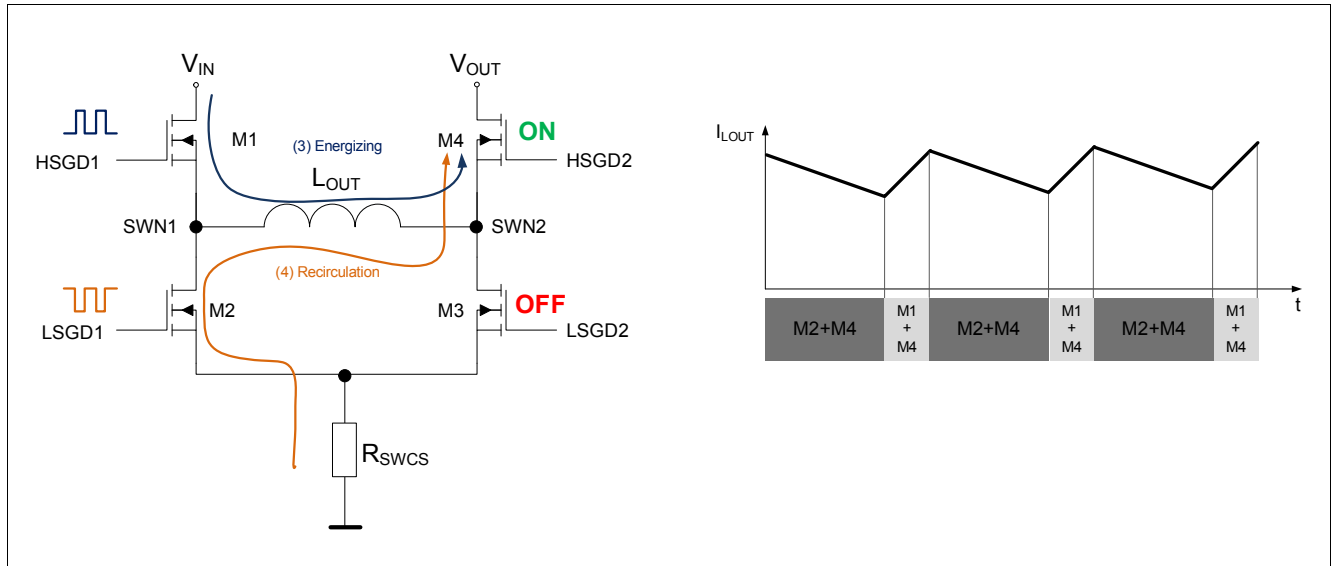

Figure 14 4 switches H-Bridge architecture in BUCK mode

Simplified comparison of 4 switches architecture to traditional asynchronous Buck approach.

- M3 is always OFF in this mode (open).
- M4 is always ON in this mode (closed connection inductor to  $V_{OUT}$ ).
- M2 acts as a synchronous diode, with significantly lower conduction losses ( $I^2 \times R_{DS(ON)}$  vs.  $0.7 V \times I$ )

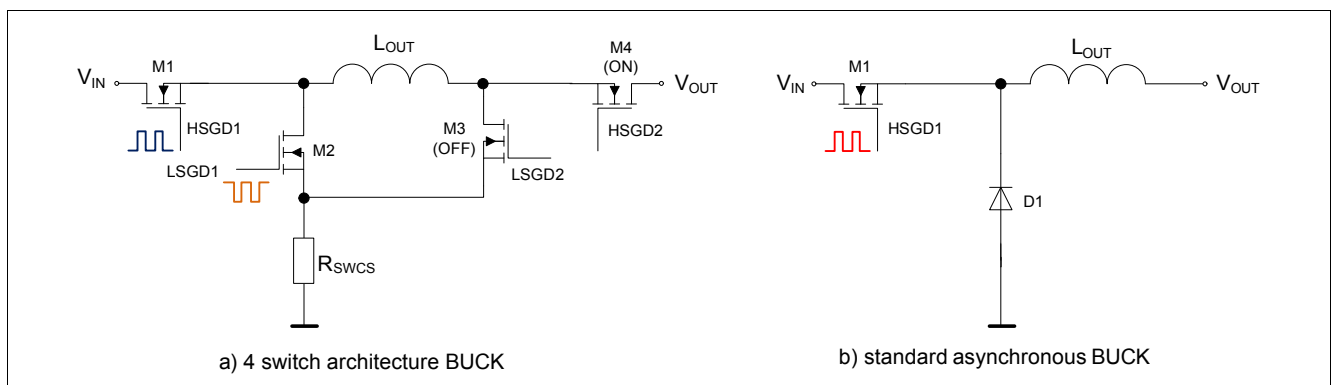

Figure 15 4 switches H-Bridge architecture in BUCK mode compared to standard async BUCK

6.4.3 Buck-Boost mode ( $V_{IN} \sim V_{OUT}$ )

- When  $V_{IN}$  is close to  $V_{OUT}$  the controller is in Buck-Boost operation
- All switches are switching in buck-boost operation. The direct energy transfer from the Input to the output ( $M1+M4 = ON$ ) is beneficial to reduce ripple current and improves the energy efficiency of the Buck-Boost control scheme
- The two buck boost waveforms and switching behaviors are displayed in [Figure 16](#) below

Regulator Description

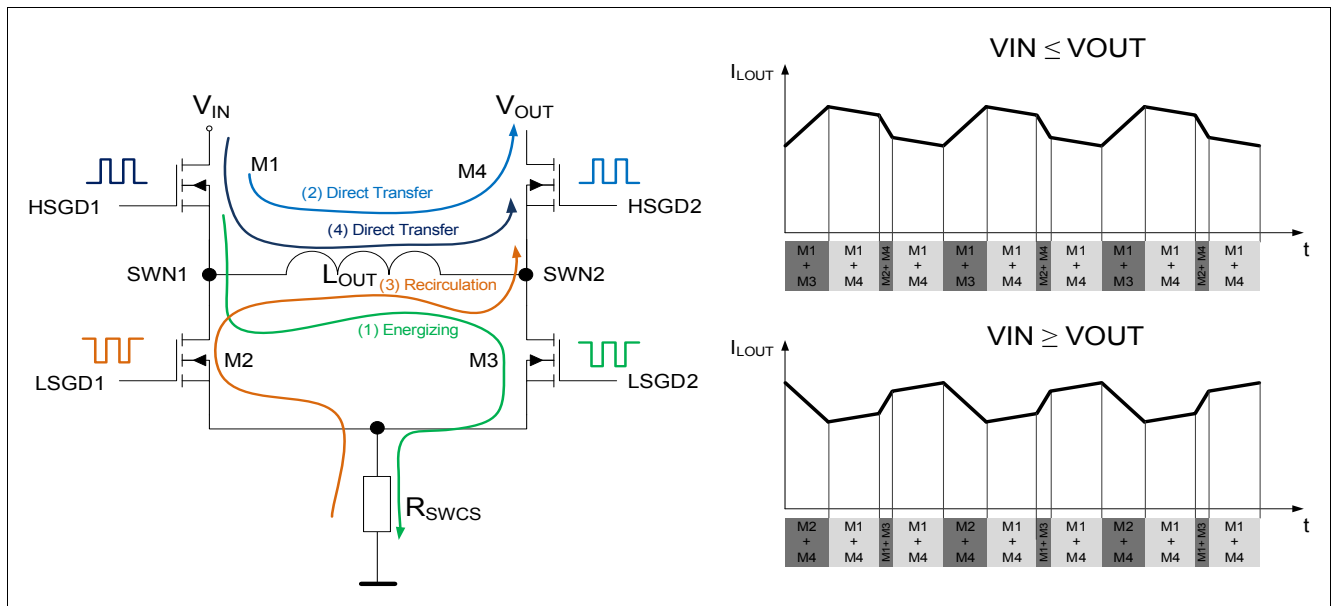

Figure 16 4 switches H-Bridge architecture in BUCK-BOOST mode

### 6.5 Flexible current sense

The flexible current sense implementation enables highside and lowside current sensing.

The [Figure 17](#) displays the application examples for the highside and lowside current sense concept.

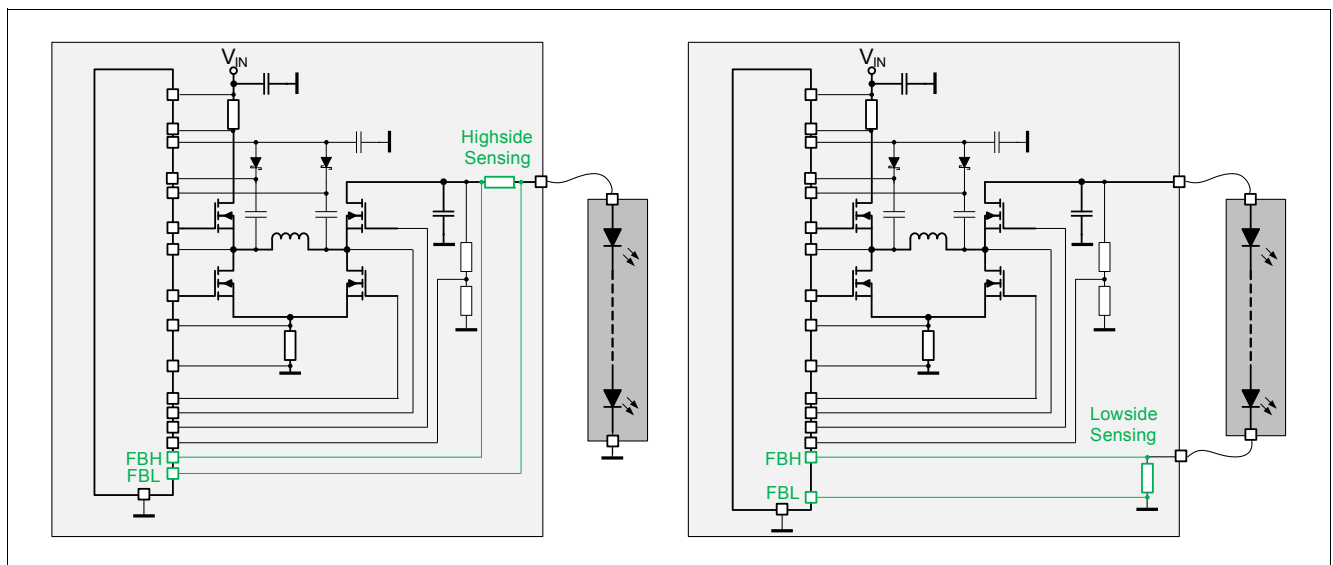

Figure 17 Highside and lowside current sensing - TLD5190

Regulator Description

### 6.6 Programming Output Voltage (Constant Voltage Regulation)

For a voltage regulator, the output voltage can be set by selecting the values  $R_{FB1}$ ,  $R_{FB2}$  and  $R_{FB3}$  according to the following [Equation \(6.4\)](#):

$$V_{OUT} = \left( I_{FBH} + \frac{V_{FBH-FBL}}{R_{FB2}} \right) \cdot R_{FB1} + \left( \frac{V_{FBH-FBL}}{R_{FB2}} - I_{FBL} \right) \cdot R_{FB3} + V_{FBH-FBL} \quad (6.4)$$

If Analog dimming is performed, due to the variations on the  $I_{FBL}$  ( $I_{FBL\_HSS}$  (P\_6.4.9) and  $I_{FBL\_LSS}$  (P\_6.4.40)) current on the entire voltage spanning, a non linearity on the output voltage may be observed. To minimize this effect RFBx resistors should be properly dimensioned.

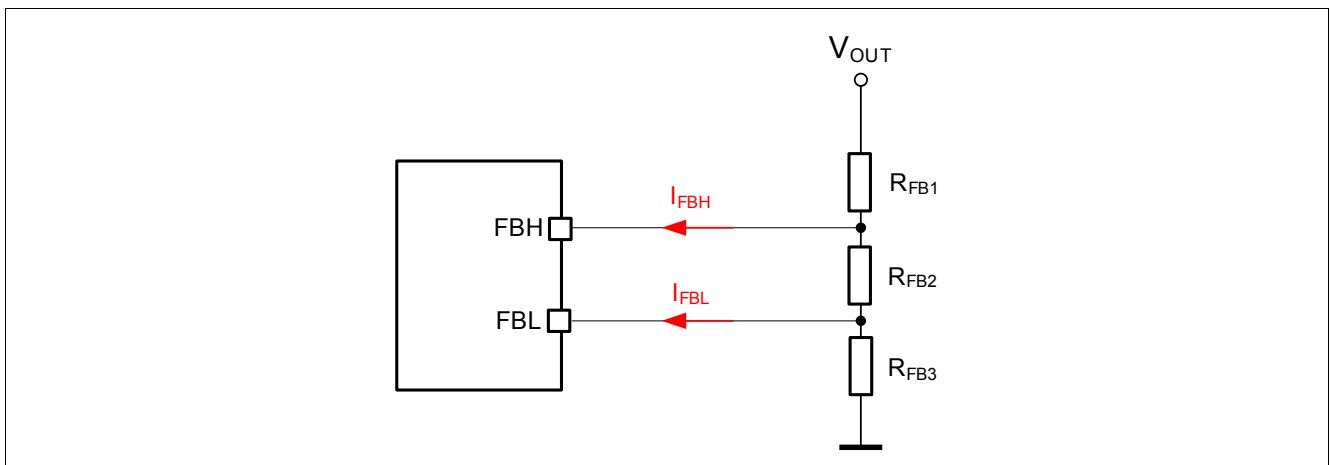

Figure 18 Programming Output Voltage (Constant Voltage Regulation)



Regulator Description

6.7 Electrical Characteristics

Table 6 EC Regulator

$V_{IN} = 8\text{ V to }36\text{ V}$ ,  $T_J = -40^\circ\text{C to }+150^\circ\text{C}$ , all voltages with respect to AGND (unless otherwise specified)

Parameter	Symbol	Values			Unit	Note or Test Condition	Number
		Min.	Typ.	Max.			
<b>Regulator:</b>							
$V_{(FBH-FBL)}$ threshold	$V_{(FBH-FBL)}$	145.5	150	154.5	mV	$V_{SET} = 2\text{ V}$ ;	P_6.4.1
$V_{(FBH-FBL)}$ threshold @ analog dimming 10%	$V_{(FBH-FBL)_10}$	10	15	20	mV	$V_{SET} = 0.32\text{ V}$ ;	P_6.4.6
FBH Bias current @ highside sensing setup	$I_{FBH\_HSS}$	65	110	155	$\mu\text{A}$	<sup>1)</sup> $V_{FBL} = 7\text{ V}$ ; $V_{FBH-FBL} = 150\text{ mV}$ ;	P_6.4.8
FBL Bias current @ highside sensing setup	$I_{FBL\_HSS}$	17	30	43	$\mu\text{A}$	<sup>1)</sup> $V_{FBL} = 7\text{ V}$ ; $V_{FBH-FBL} = 150\text{ mV}$ ;	P_6.4.9
FBH Bias current @ lowside sensing setup	$I_{FBH\_LSS}$	-7.5	-4	-2.5	$\mu\text{A}$	<sup>1)</sup> $V_{FBL} = 0\text{ V}$ ; $V_{FBH-FBL} = 150\text{ mV}$ ;	P_6.4.39
FBL Bias current @ lowside sensing setup	$I_{FBL\_LSS}$	-45	-30	-20	$\mu\text{A}$	<sup>1)</sup> $V_{FBL} = 0\text{ V}$ ; $V_{FBH-FBL} = 150\text{ mV}$ ;	P_6.4.40
FBH-FBL High Side sensing entry threshold	$V_{FBH\_HSS\_inc}$	-	2	-	V	<sup>1)</sup> $V_{FBH1}$ increasing;	P_6.9.1
FBH-FBL High Side sensing exit threshold	$V_{FBH\_HSS\_dec}$	-	1.75	-	V	<sup>1)</sup> $V_{FBH}$ decreasing;	P_6.9.2
OUT Current sense Amplifier $g_m$	$IFBx_{gm}$	-	890	-	$\mu\text{S}$	<sup>1)</sup>	P_6.4.10
Output Monitor Voltage	$V_{IOUTMON}$	1.33	1.4	1.47	V	$V_{FBH-FBL} = 150\text{ mV}$ ;	P_6.4.11
Maximum BOOST Duty Cycle	$D_{BOOST\_MAX}$	89	91	93	%	<sup>1)</sup> $f_{sw} = 300\text{ kHz}$ ;	P_6.4.12
Input Current Sense threshold $V_{IIN1-IIN2}$	$V_{IIN1-IIN2}$	46	50	54	mV	-	P_6.4.13
Input Current sense Amplifier $g_m$	$I_{IN\_gm}$	-	2.12	-	mS	<sup>1)</sup>	P_6.4.14
Input current Monitor Voltage	$V_{IINMON}$	0.95	1	1.05	V	<sup>1)</sup> $V_{IIN1-IIN2} = 50\text{ mV}$ ; $V_{IIN1} = V_{VIN(ON)}$ to 55 V;	P_6.4.15
Switch Peak Over Current Threshold - BOOST	$V_{SWCS\_boost}$	40	50	60	mV	<sup>1)</sup>	P_10.8.15
Switch Peak Over Current Threshold - BUCK	$V_{SWCS\_buck}$	-60	-50	-40	mV	<sup>1)</sup>	P_10.8.16
<b>Soft Start</b>							
Soft Start pull up current	$I_{Soft\_Start\_PU}$	22	26	32	$\mu\text{A}$	$V_{Soft\_Start} = 1\text{ V}$ ;	P_6.4.19
Soft Start pull down current	$I_{Soft\_Start\_PD}$	2.2	2.6	3.2	$\mu\text{A}$	$V_{Soft\_Start} = 1\text{ V}$ ;	P_6.4.20

Regulator Description

**Table 6 EC Regulator (cont'd)**

$V_{IN} = 8\text{ V to }36\text{ V}$ ,  $T_j = -40^\circ\text{C to }+150^\circ\text{C}$ , all voltages with respect to AGND (unless otherwise specified)

Parameter	Symbol	Values			Unit	Note or Test Condition	Number
		Min.	Typ.	Max.			
Soft Start Latch-OFF Threshold	$V_{\text{Soft\_Start\_L OFF}}$	1.65	1.75	1.85	V	–	P_6.4.21
Soft Start Reset Threshold	$V_{\text{Soft\_Start\_R ESET}}$	0.1	0.2	0.3	V	–	P_6.4.22
Soft Start Voltage during regulation	$V_{\text{Soft\_Start\_r eg}}$	1.9	2	2.1	V	<sup>1)</sup> No Faults	P_6.9.3

**Oscillator**

Switching Frequency	$f_{\text{SW}}$	285	300	315	kHz	$T_j = 25^\circ\text{C}$ ; $R_{\text{FREQ}} = 37.4\text{ k}\Omega$ ;	P_6.4.23
SYNC Frequency	$f_{\text{SYNC}}$	200	–	700	kHz	–	P_6.4.24
SYNC Turn On Threshold	$V_{\text{SYNC,ON}}$	2	–	–	V	–	P_6.4.25
SYNC Turn Off Threshold	$V_{\text{SYNC,OFF}}$	–	–	0.8	V	–	P_6.4.26
SYNC High Input Current	$I_{\text{SYNC,H}}$	15	30	45	$\mu\text{A}$	$V_{\text{SYNC}} = 2.0\text{ V}$ ;	P_6.4.62
SYNC Low Input Current	$I_{\text{SYNC,L}}$	6	12	18	$\mu\text{A}$	$V_{\text{SYNC}} = 0.8\text{ V}$ ;	P_6.4.63

**Gate Driver for external Switch**

Gate Driver undervoltage threshold $V_{\text{BST1,2}} - V_{\text{SWN1,2\_UVth}}$	$V_{\text{BST1,2}} - V_{\text{SWN1,2\_UVth}}$	3.4	–	4	V	$V_{\text{BST1,2}} - V_{\text{SWN1,2}}$ decreasing;	P_6.4.64
HSGD1,2 NMOS driver on-state resistance (Gate Pull Up)	$R_{\text{DS(ON\_PU) HS}}$	1.4	2.3	3.7	$\Omega$	$V_{\text{BST1,2}} - V_{\text{SWN1,2}} = 5\text{ V}$ ; $I_{\text{source}} = 100\text{ mA}$ ;	P_6.4.28
HSGD1,2 NMOS driver on-state resistance (Gate Pull Down)	$R_{\text{DS(ON\_PD) HS}}$	0.6	1.2	2.2	$\Omega$	$V_{\text{BST1,2}} - V_{\text{SWN1,2}} = 5\text{ V}$ ; $I_{\text{sink}} = 100\text{ mA}$ ;	P_6.4.29
LSGD1,2 NMOS driver on-state resistance (Gate Pull Up)	$R_{\text{DS(ON\_PU) LS}}$	1.4	2.3	3.7	$\Omega$	$V_{\text{IVCC\_EXT}} = 5\text{ V}$ ; $I_{\text{source}} = 100\text{ mA}$ ;	P_6.4.30
LSGD1,2 NMOS driver on-state resistance (Gate Pull Down)	$R_{\text{DS(ON\_PD) L S}}$	0.4	1.2	1.8	$\Omega$	$V_{\text{IVCC\_EXT}} = 5\text{ V}$ ; $I_{\text{sink}} = 100\text{ mA}$ ;	P_6.4.31
HSGD1,2 Gate Driver peak sourcing current	$I_{\text{HSGD1,2\_SR C}}$	380	–	–	mA	<sup>1)</sup> $V_{\text{HSGD1,2}} - V_{\text{SWN1,2}} = 1\text{ V to }4\text{ V}$ ; $V_{\text{BST1,2}} - V_{\text{SWN1,2}} = 5\text{ V}$	P_6.4.32
HSGD1,2 Gate Driver peak sinking current	$I_{\text{HSGD1,2\_SN K}}$	410	–	–	mA	<sup>1)</sup> $V_{\text{HSGD1,2}} - V_{\text{SWN1,2}} = 4\text{ V to }1\text{ V}$ ; $V_{\text{BST1,2}} - V_{\text{SWN1,2}} = 5\text{ V}$	P_6.4.33

Regulator Description

**Table 6** EC Regulator (cont'd)

$V_{IN} = 8\text{ V to }36\text{ V}$ ,  $T_J = -40^\circ\text{C to }+150^\circ\text{C}$ , all voltages with respect to AGND (unless otherwise specified)

Parameter	Symbol	Values			Unit	Note or Test Condition	Number
		Min.	Typ.	Max.			
LSGD1,2 Gate Driver peak sourcing current	$I_{\text{LSGD1,2\_SRC}}$	370	–	–	mA	<sup>1)</sup> $V_{\text{LSGD1,2}} = 1\text{ V to }4\text{ V};$ $V_{\text{IVCC\_EXT}} = 5\text{ V};$	P_6.4.34
LSGD1,2 Gate Driver peak sinking current	$I_{\text{LSGD1,2\_SNK}}$	550	–	–	mA	<sup>1)</sup> $V_{\text{LSGD1,2}} = 4\text{ V to }1\text{ V};$ $V_{\text{IVCC\_EXT}} = 5\text{ V};$	P_6.4.35
LSGD1,2 OFF to HSGD1,2 ON delay	$t_{\text{LSOFF-HSON\_delay}}$	15	30	40	ns	<sup>1)</sup>	P_6.4.36
HSGD1,2 OFF to LSGD1,2 ON delay	$t_{\text{HSOFF-LSON\_delay}}$	35	60	75	ns	<sup>1)</sup>	P_6.4.37

<sup>1)</sup> Not subject to production test, specified by design

## Digital Dimming Function

### 7 Digital Dimming Function

PWM dimming is adopted to vary LEDs brightness with greatly reduced chromaticity shift. PWM dimming achieves brightness reduction by varying the duty cycle of a constant current in the LED string.

#### 7.1 Description

A PWM signal can be transmitted to the TLD5190 as described below.

##### PWM via direct interface

The PWMI pin can be fed with a pulse width modulated (PWM) signals, this enables when HIGH and disables when LOW the gate drivers of the main switches.

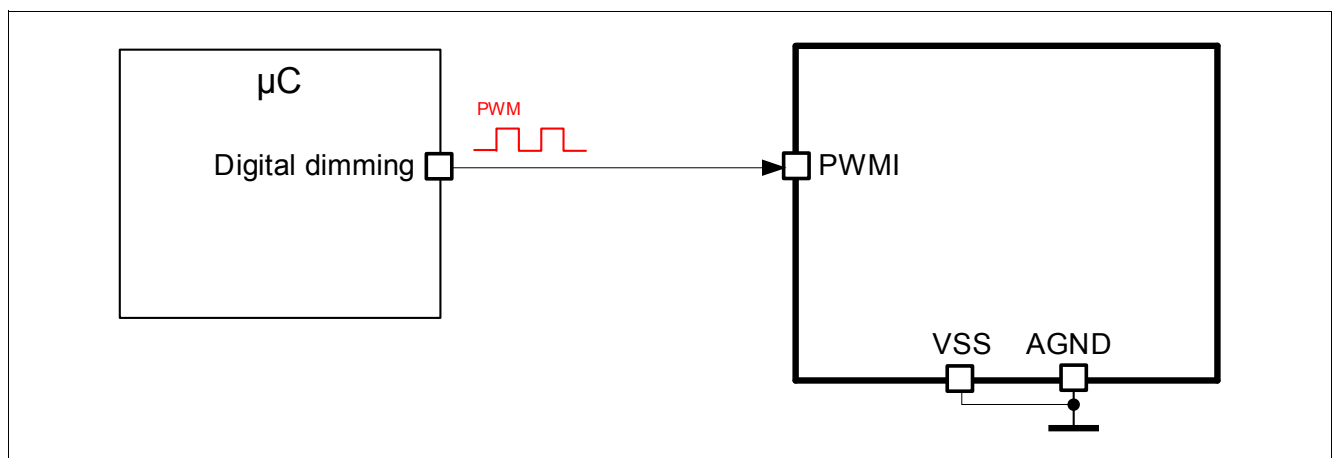

Figure 19 Digital Dimming Overview

To avoid unwanted output overshoots due to not soft start assisted startups, PWM dimming in LOW state should not be used to suspend the output current for long time intervals. To stop in a safe manner EN/INUVLO=LOW can be used.

Digital Dimming Function

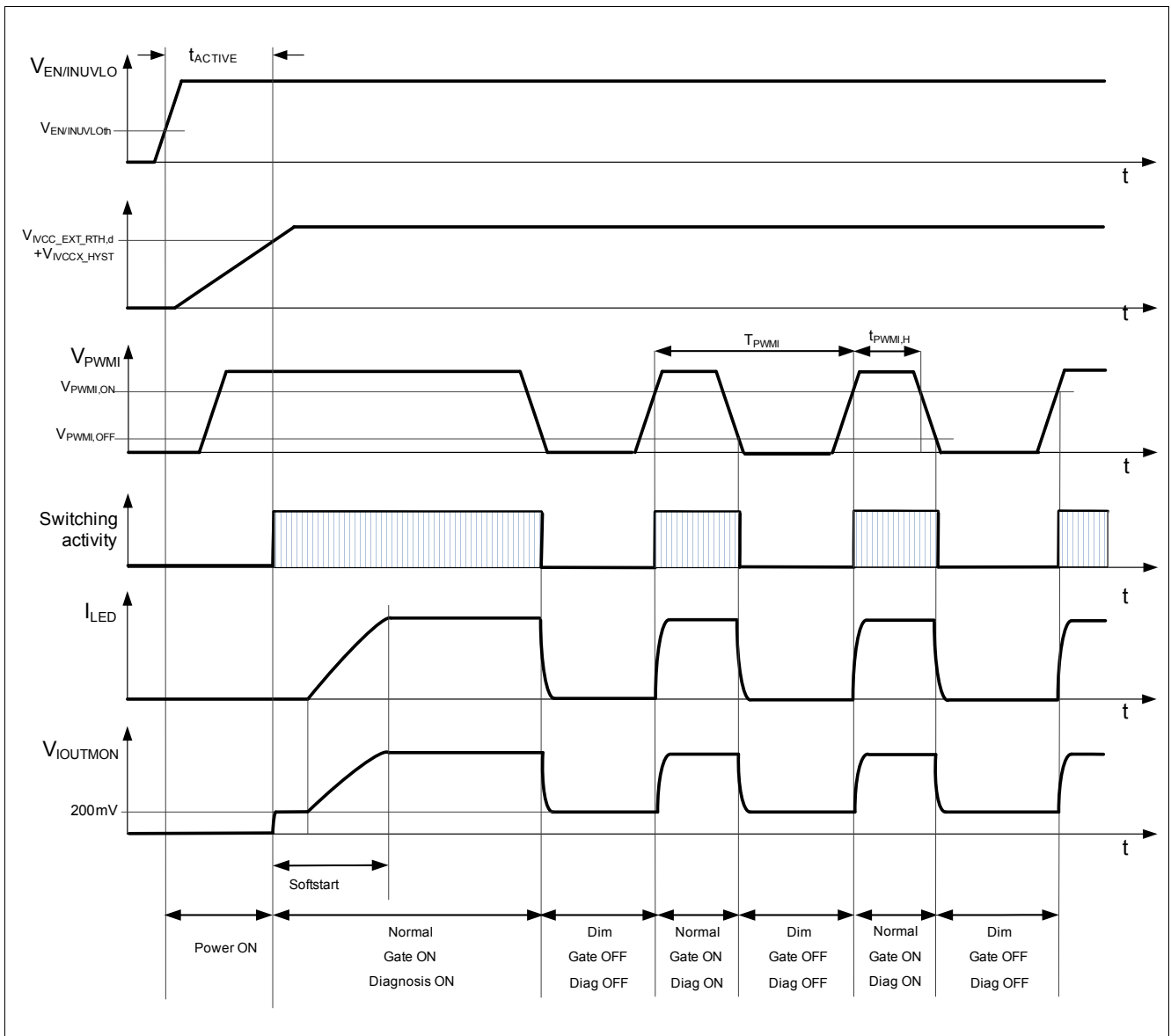

Figure 20 Timing Diagram LED Dimming and Start up behavior example ( $V_{VIN}$  stable in the functional range and not during startup)

Digital Dimming Function

## 7.2 Electrical Characteristics

**Table 7 EC Digital Dimming**

$V_{IN} = 8\text{ V to }36\text{ V}$ ,  $T_J = -40^\circ\text{C to }+150^\circ\text{C}$ , all voltages with respect to AGND; (unless otherwise specified)

Parameter	Symbol	Values			Unit	Note or Test Condition	Number
		Min.	Typ.	Max.			
<b>PWMI Input:</b>							
PWMI Turn On Threshold	$V_{PWMI,ON}$	2	–	–	V	–	P_7.2.1
PWMI Turn Off Threshold	$V_{PWMI,OFF}$	–	–	0.8	V	–	P_7.2.2
PWMI High Input Current	$I_{PWMI,H}$	15	30	45	$\mu\text{A}$	$V_{PWMI} = 2.0\text{ V}$ ;	P_7.2.4
PWMI Low Input Current	$I_{PWMI,L}$	6	12	18	$\mu\text{A}$	$V_{PWMI} = 0.8\text{ V}$ ;	P_7.2.5

## 8 Analog Dimming

The analog dimming feature allows further control of the output current. This approach is used to:

- Reduce the default current in a narrow range to adjust to different binning classes of the used LEDs.
- Adjust the load current to enable the usage of one hardware for several LED types where different current levels are required.
- Reduce the current at high temperatures (protect LEDs from overtemperature).
- Reduce the current at low input voltages (for example, cranking-pulse breakdown of the supply or power derating).

### 8.1 Description

The analog dimming feature is adjusting the average load current level via the control of the feedback error Amplifier voltage ( $V_{FBH-FBL}$ ).

The SET pin is used to adjust the mean output current/voltage. The  $V_{SET}$  range where analog dimming is enabled is from 200 mV to 1.5 V. Different application scenarios are described in [Figure 22](#).

#### Using the SET pin to adjust the output current:

For the calculation of the output current  $I_{OUT}$  the following [Equation \(8.1\)](#) is used:

$$I_{OUT} = \frac{V_{FBH} - V_{FBL}}{R_{FB}} \quad (8.1)$$

A decrease of the average output current can be achieved by controlling the voltage at the SET pin ( $V_{SET}$ ) between 0.2 V and 1.4 V. The mathematical relation is given in the [Equation \(8.2\)](#) below:

$$I_{OUT} = \frac{V_{SET} - 200 \text{ mV}}{R_{FB} \cdot 8} \quad (8.2)$$

If  $V_{SET}$  is 200 mV (typ.) the LED current is only determined by the internal offset voltages of the comparators. To assure the switching activity is stopped and  $I_{OUT} = 0$ ,  $V_{SET}$  has to be < 100 mV, see [Figure 21](#).

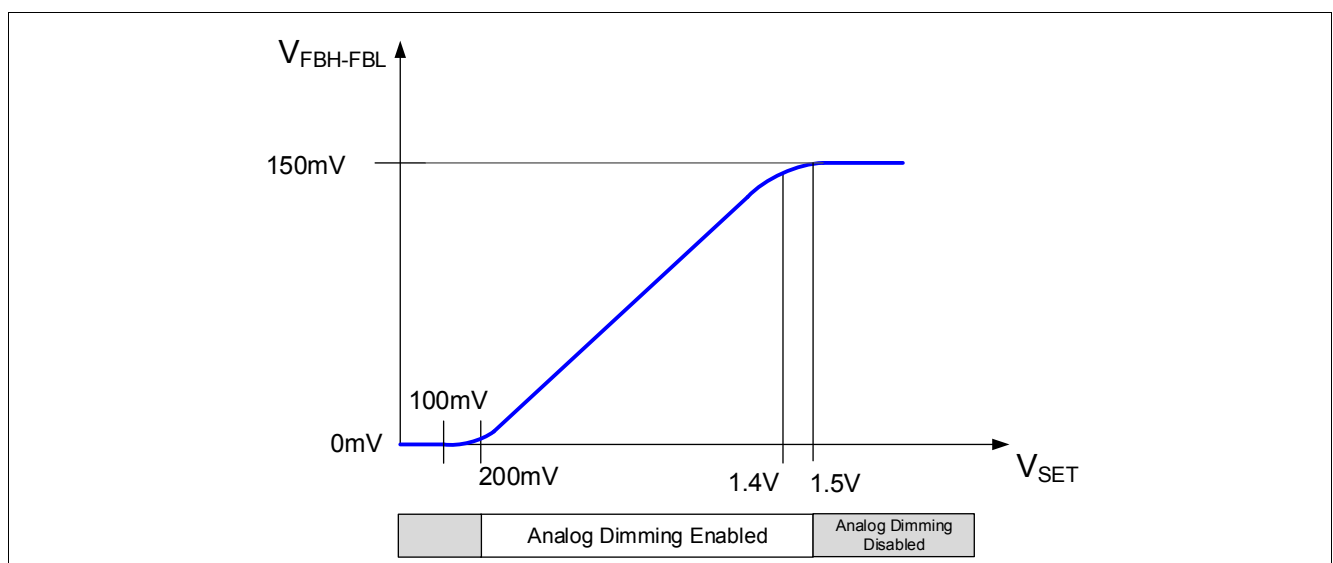

**Figure 21** Analog Dimming Overview

Analog Dimming

Multi-purpose usage of the Analog dimming feature

- 1) A  $\mu\text{C}$  integrated digital analog converter (DAC) output or a stand alone DAC can be used to supply the SET pin of the TLD5190.
- 2) The usage of an external resistor divider connected between  $V_{\text{REF}}$  (accurate regulated supply output) SET and GND can be chosen for systems without  $\mu\text{C}$  on board. The concept allows control of the LED current by placing low power resistors.
- 3) Furthermore a temperature sensitive resistor (Thermistor) to protect the LED loads from thermal destruction can be connected.
- 4) If the analog dimming feature is not needed, the SET pin should be connected to the VREF pin.
- 5) Instead of a DAC, the  $\mu\text{C}$  can provide a PWM signal and an external R-C filter to produce a constant voltage for the analog dimming. The voltage level depends on the PWM frequency ( $f_{\text{PWM}}$ ) and duty cycle which can be controlled by the  $\mu\text{C}$  software after reading the coding resistor placed on the LED module.

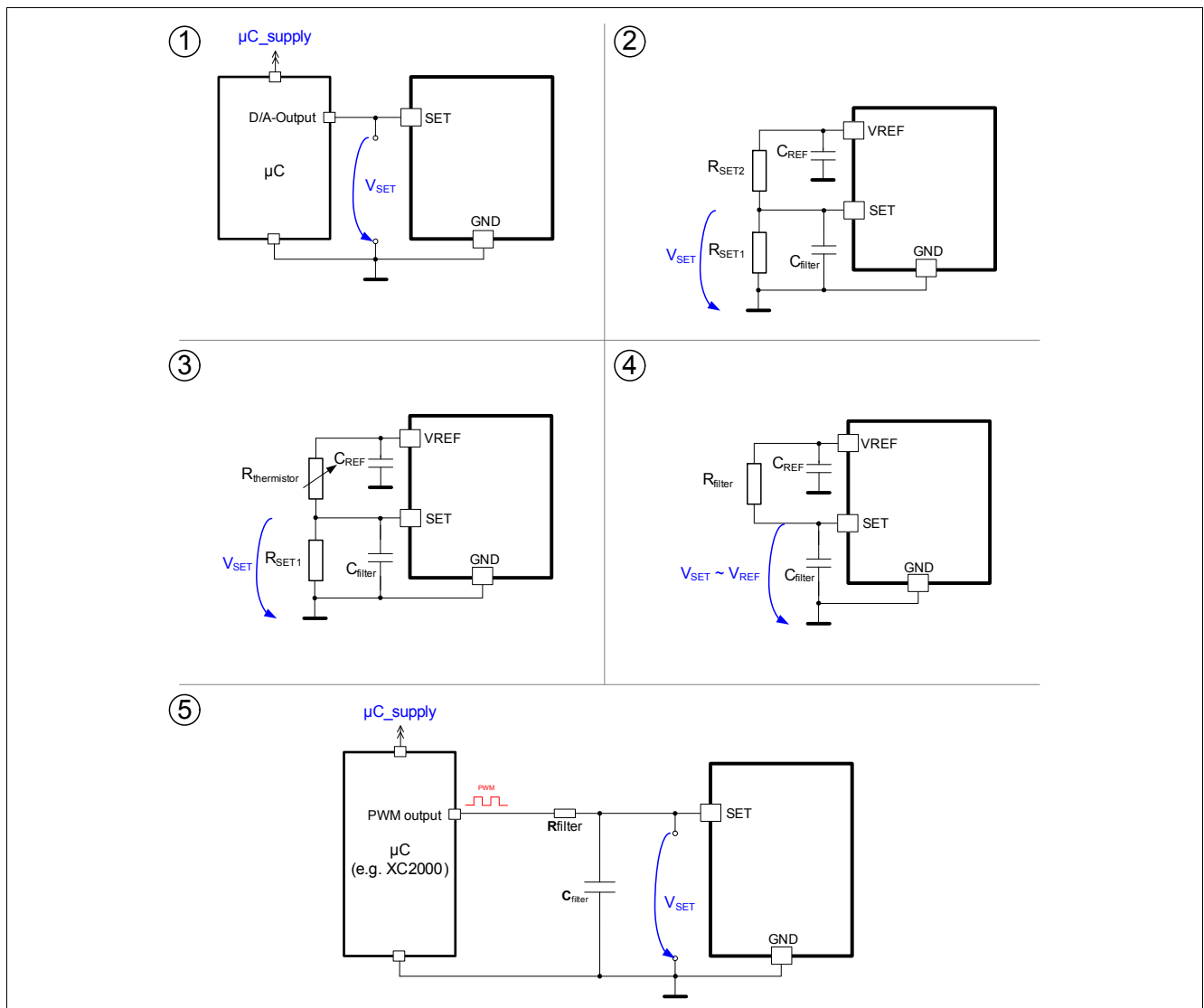

Figure 22 Different use cases for analog dimming pin SET

8.2 Electrical Characteristics



Analog Dimming

**Table 8 EC Analog Dimming**

$V_{IN} = 8\text{ V to }36\text{ V}$ ,  $T_J = -40^\circ\text{C to }+150^\circ\text{C}$ , all voltages with respect to AGND; (unless otherwise specified)

Parameter	Symbol	Values			Unit	Note or Test Condition	Number
		Min.	Typ.	Max.			
Source current on SET Pin	$I_{SET\_source}$	–	–	1	$\mu\text{A}$	<sup>1)</sup> $V_{SET} = 0.2\text{ V to }1.4\text{ V}$ ; <b>P_8.3.4</b>	

1) Specified by design: not subject to production test.

## 9 Linear Regulator

The TLD5190 features an integrated voltage regulator for the supply of the internal gate driver stages. Furthermore an external voltage regulator can be connected to the IVCC\_EXT pin to achieve an alternative gate driver supply if required.

### 9.1 IVCC Description

When the IVCC pin is connected to the IVCC\_EXT pin, the internal linear voltage regulator supplies the internal gate drivers with a typical voltage of 5 V and current up to  $I_{LIM}$  (P\_9.2.2). An external output capacitor with low ESR is required on pin IVCC for stability and buffering transient load currents. During normal operation the external MOSFET switches will draw transient currents from the linear regulator and its output capacitor (Figure 23, drawing A). Proper sizing of the output capacitor must be considered to supply sufficient peak current to the gate of the external MOSFET switches. A minimum capacitance value is given in parameter  $C_{IVCC}$  (P\_9.2.4).

#### Alternative IVCC\_EXT Supply Concept:

The IVCC\_EXT pin can be used for an external voltage supply to alternatively supply the MOSFET Gate drivers. This concept is beneficial in the high input voltage range to avoid power losses in the IC (Figure 23, drawing B).

#### Integrated undervoltage protection for the external switching MOSFET:

An integrated undervoltage reset threshold circuit monitors the linear regulator output voltage. This undervoltage reset threshold circuit will turn OFF the gate drivers in case the IVCC or IVCC\_EXT voltage falls below their undervoltage Reset switch OFF Thresholds  $V_{IVCC\_RTH,d}$  (P\_9.2.9) and  $V_{IVCC\_EXT\_RTH,d}$  (P\_9.2.5).

The Undervoltage Reset threshold for the IVCC and the IVCC\_EXT pins help to protect the external switches from excessive power dissipation by ensuring the gate drive voltage is sufficient to enhance the gate of the external logic level N-channel MOSFETs.

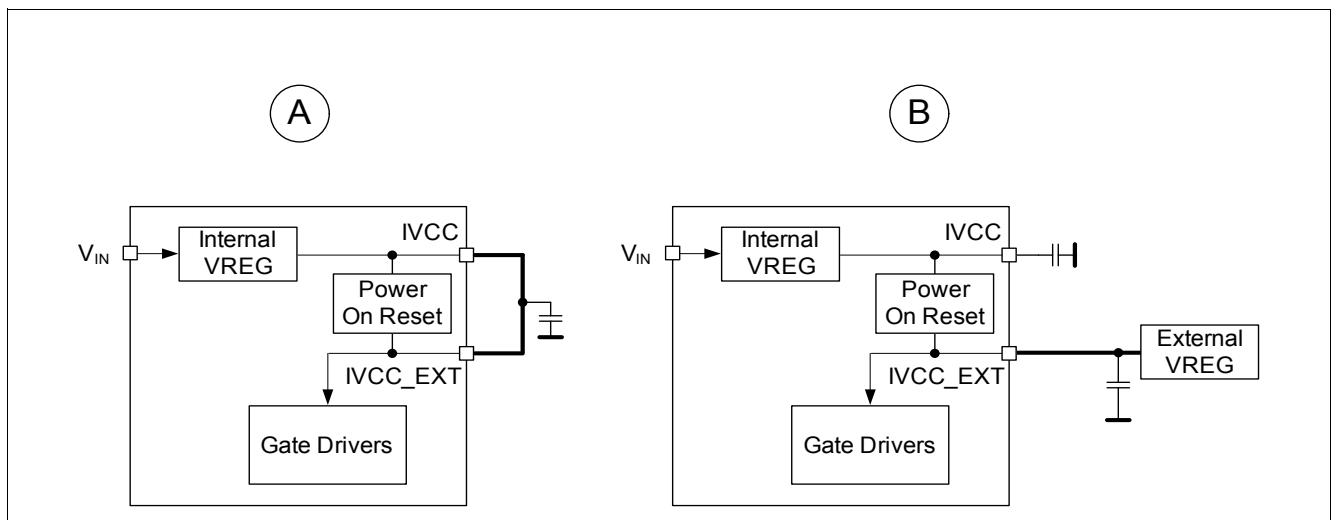

Figure 23 Voltage Regulator Configurations

Linear Regulator

## 9.2 Electrical Characteristics

**Table 9 EC Line Regulator**

$V_{IN} = 8\text{ V to }36\text{ V}$ ,  $T_J = -40^\circ\text{C to }+150^\circ\text{C}$ , all voltages with respect to AGND; (unless otherwise specified)

Parameter	Symbol	Values			Unit	Note or Test Condition	Number
		Min.	Typ.	Max.			
<b>IVCC</b>							
Output Voltage	$V_{IVCC}$	4.8	5	5.2	V	$V_{IN} = 13.5\text{ V};$ $0.1\text{ mA} \leq I_{IVCC} \leq 50\text{ mA};$	P_9.2.1
Output Current Limitation	$I_{LIM}$	70	90	110	mA	<sup>1)</sup> $V_{IVCC} = 4\text{ V};$	P_9.2.2
Drop out Voltage ( $V_{IN} - V_{IVCC}$ )	$V_{DR}$	–	200	350	mV	$V_{IN} = 5\text{ V};$ $I_{IVCC} = 10\text{ mA};$	P_9.2.3
IVCC Buffer Capacitor	$C_{IVCC}$	10	–	–	$\mu\text{F}$	<sup>1) 2)</sup>	P_9.2.4
IVCC_EXT Undervoltage Reset switch OFF Threshold	$V_{IVCC\_EXT\_R_{TH,d}}$	3.7	3.9	4.1	V	<sup>3)</sup> $V_{IVCC\_EXT}$ decreasing;	P_9.2.5
IVCC Undervoltage Reset switch OFF Threshold	$V_{IVCC\_RTH,d}$	3.7	3.9	4.1	V	<sup>3)</sup> $V_{IVCC}$ decreasing;	P_9.2.9
IVCC and IVCC_EXT Undervoltage Hysterisis	$V_{IVCCX\_HYST}$	0.3	0.33	0.36	V	$V_{IVCC}$ increasing; $V_{IVCC\_EXT}$ increasing;	P_9.2.6
VREF voltage	$V_{REF}$	1.94	2	2.06	V	$0 \leq I_{VREF} \leq 200\ \mu\text{A};$	P_9.2.8

1) Not subject to production test, specified by design

2) Minimum value given is needed for regulator stability; application might need higher capacitance than the minimum. Use capacitors with LOW ESR.

3) Selection of external switching MOSFET is crucial.  $V_{IVCC\_EXT\_RTH,d}$  and  $V_{IVCC\_RTH,d}$  min. as worst case  $V_{GS}$  must be considered.

## 10 Protection and Diagnostic Functions

### 10.1 Description

The TLD5190 has integrated circuits to diagnose and protect against overvoltage, open load, short circuits of the load and overtemperature faults.

In IDLE state, only the Over temperature Shut Down, Over Temperature Warning, IVCC or IVCC\_EXT Undervoltage Monitor or  $V_{EN/INUVLO}$  Undervoltage Monitor are reported according to specifications.

In [Figure 24](#) a summary of the protection, diagnostic and monitor functions is displayed.

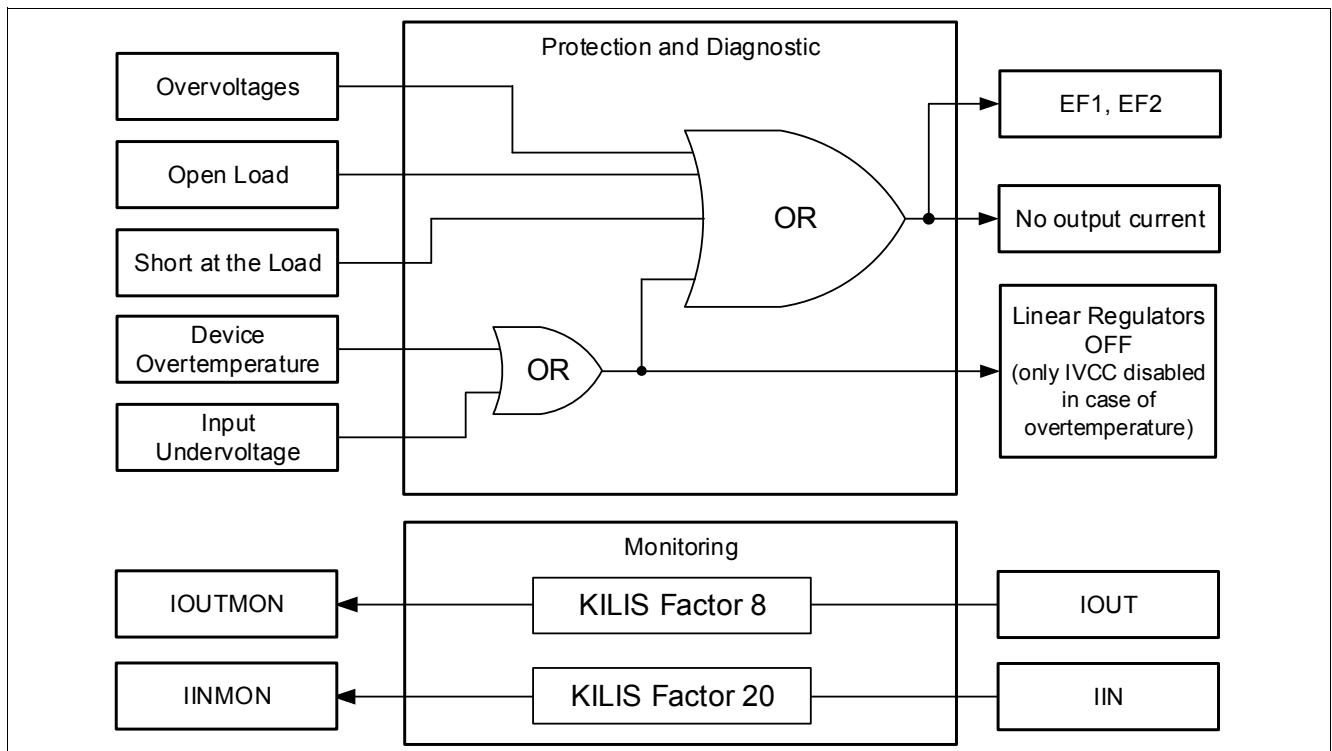

Figure 24 Protection, Diagnostic and Monitoring Overview - TLD5190

Input		Output			
Condition	Level*	EF1	EF2	Gate Drivers	IVCC
Open Load / Overvoltages	False	H	H	Sw*	Active
	True	H	L	L	Active
Shorted LED fault	False	H	H	Sw*	Active
	True	L	H	L	Active
Overtemperature	False	H	H	Sw*	Active
	True	L	L	L	Shutdown

\*Note:  
Sw = Switching  
False = Condition does not exist  
True = Condition does exist

Figure 25 Diagnostic Truth Table - TLD5190

Note: A device Overtemperature event overrules all other fault events!

## 10.2 Output Overvoltage, Open Load, Short circuit protection

The VFB pin measures the voltage on the application output and in accordance with the populated resistor divider, short to ground, open load and output overvoltage thresholds are set. Refer to [Figure 26](#) for more details.

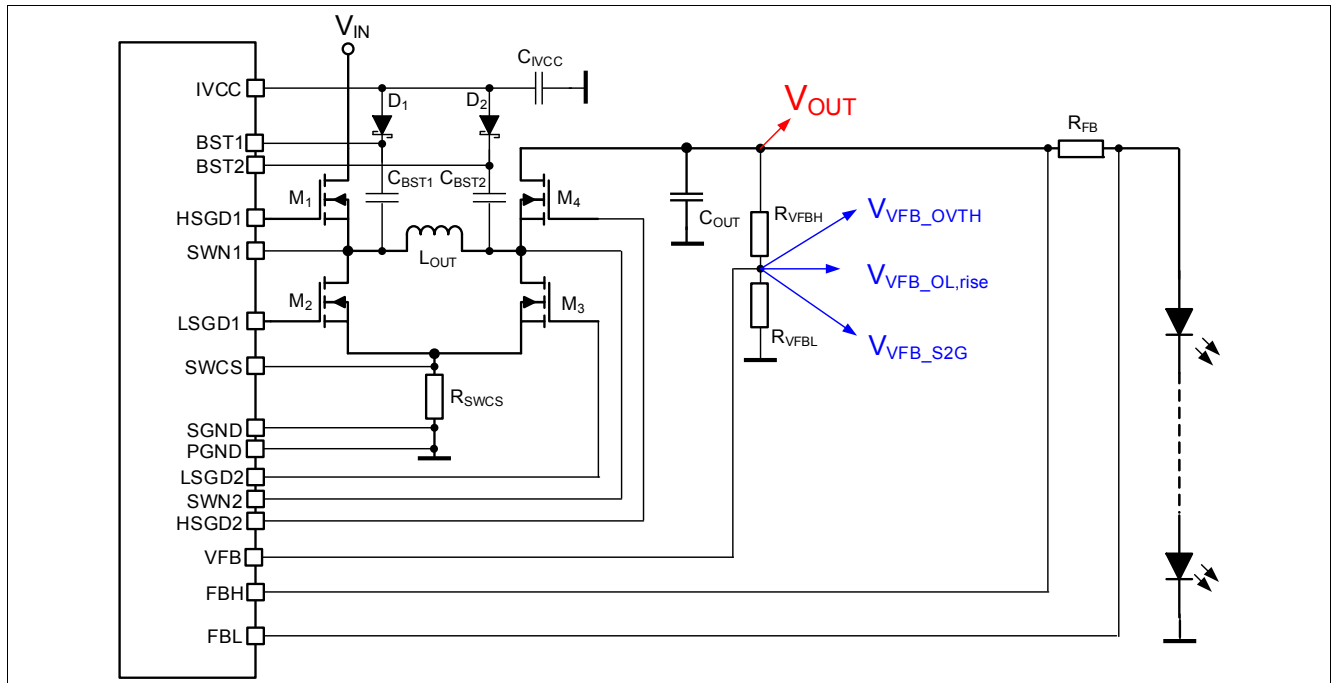

Figure 26 VFB Protection Pin - Overview

### 10.2.1 Short Circuit protection

The device detects a short circuit at the output if this condition is verified:

- The pin VFB falls below the threshold voltage  $V_{VFB\_S2G}$  for at least 8 clock cycles

During the rising edge of the Soft Start the short circuit detection via VFB is ignored until  $V_{SOFT\_START\_LOFF}$  (see [Figure 8](#)).

A voltage divider between  $V_{OUT}$ , VFB pin and AGND is used to adjust the application short circuit thresholds following [Equation \(10.1\)](#).

$$V_{short\_led} = V_{VFB\_S2G} \cdot \frac{R_{VFBH} + R_{VFBL}}{R_{VFBL}} \quad (10.1)$$

The TLD5190 provides an open-drain status pin, EF1, which pulls low when the short circuit is detected. The only time the FB pin will be below  $V_{VFB\_S2G}$  is during start-up or if the LEDs are shorted. During start-up the TLD5190 ignores the detection of a short circuit or an open load until the soft-start capacitor reaches 1.75 V. To prevent false tripping after startup, a large enough soft-start capacitor must be used to allow the output to get up to approximately 50% of the final value.

*Note: If the short circuit condition disappears, the device will re-start with the soft start routine as described in [Chapter 6.2](#).*

### 10.2.2 Overvoltage Protection

A voltage divider between  $V_{OUT}$ , VFB pin and AGND is used to adjust the overvoltage protection threshold (refer to [Figure 26](#)).

## Protection and Diagnostic Functions

To fix the overvoltage protection threshold the following [Equation \(10.2\)](#) is used:

$$V_{OUT\_OV\_protected} = V_{VFB\_OVTH} \cdot \frac{R_{VFBH} + R_{VFB_L}}{R_{VFB_L}} \quad (10.2)$$

In case of overvoltage event at the output, the open-drain status pin EF2 will toggle to LOW, while EF1 will stay at HIGH. After the overvoltage event disappeared the device will auto restart and the status pin EF2 will toggle to HIGH.

### 10.2.3 Open Load Protection

To reliably detect an open load event, two conditions need to be observed:

- 1) Voltage threshold:  $V_{VFB} > V_{VFB\_OL,rise}$
- 2) Output current information:  $V_{(FBH-FBL)} < V_{FBH\_FBL\_OL}$

During the rising edge of the Soft Start the open load detection is ignored until  $V_{SOFT\_START\_LOFF}$ .

The TLD5190 provides an open-drain status pin, EF2, which pulls low when the VFB pin is above  $V_{VFB\_OL,rise}$  threshold and the voltage across  $V_{(FBH-FBL)}$  is less than  $V_{FBH\_FBL\_OL}$ . If the open LED clamp voltage is programmed correctly using the VFB pin, then the VFB pin should never exceed 1.28 V ( $V_{VFBOL,fall}$  when the LEDs are connected).

After an Open Load error the TLD5190 is autorestarting the output control accordingly to the implemented Softstart routine. An Open Load error causes an increase of the output voltage as well. An Overvoltage condition could be reported in combination with an Open Load error (in general, multiple error detection may happen if more error detection thresholds are reached during the autorestart function, as possible consequence of reactive behavior at the output node during open load).

The COMP capacitor is discharged during an Open Load condition to prevent spikes if load reconnects. This measure could artificially generate Short Circuit detections after open loads events.

### 10.3 Input voltage monitoring, protection and power derating

Input overvoltage and undervoltage shutdown levels can both be defined through an external resistor divider, as shown in [Figure 27](#).

Both INOVLO and EN/INUVLO pin voltages are internally compared to their respective thresholds by means of hysteretic comparators.

Protection and Diagnostic Functions

Neglecting the hysteresis, the following equations hold:

$$UV_{th} = \left(1 + \frac{R_1}{R_2 + R_3}\right) \cdot EN / INUVLO_{th} \tag{10.3}$$

$$OV_{th} = \left(1 + \frac{R_1 + R_2}{R_3}\right) \cdot INOVLO_{th} \tag{10.4}$$

$$P_{IN} = \frac{V_{OUT} \cdot I_{OUT}}{\eta} \tag{10.5}$$

$$V_{IN\_boundary} = \frac{\left(\frac{V_{OUT} \cdot I_{OUT}}{\eta}\right)}{\eta} \tag{10.6}$$

$$I_{IN} = \frac{V_{IN1} - V_{IN2}}{R_{IN}} \tag{10.7}$$

$$I_{OUT} = \frac{V_{FBH} - V_{FBL}}{R_{FB}} \tag{10.8}$$

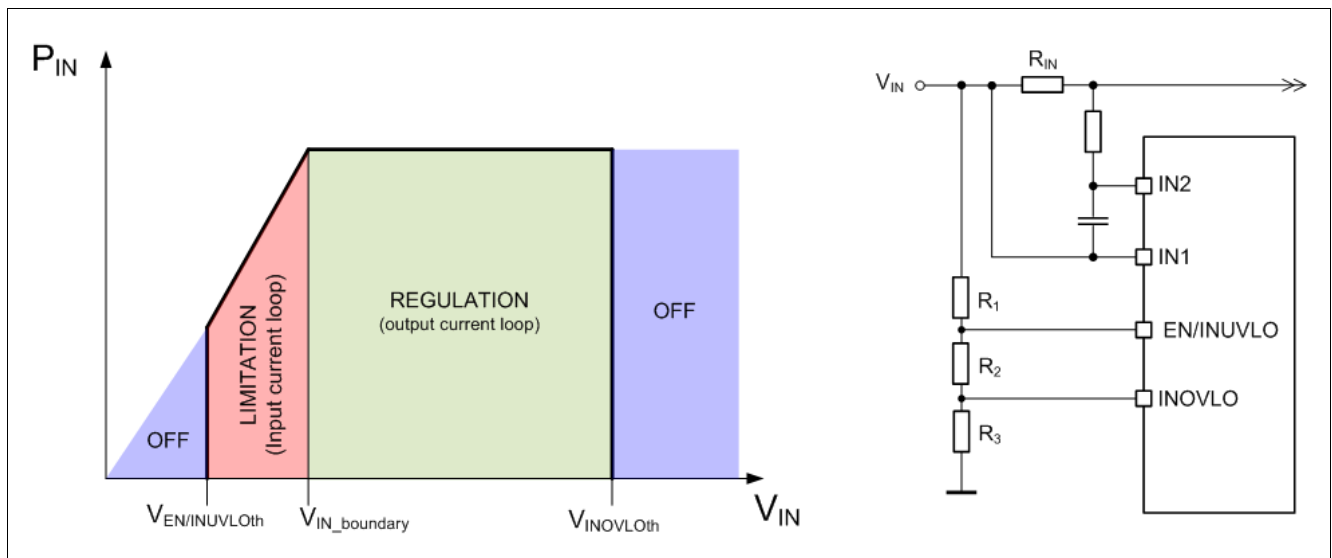

Figure 27 Input Voltage Protection

In case of overvoltage event at the input, the open-drain status pin EF2 will toggle to LOW, while EF1 will stay at HIGH. The softstart capacitor will be discharged by an internal pull down switch.

After the overvoltage event disappeared the device will auto restart with the softstart function, and the status pin EF2 will toggle to HIGH.

### 10.4 Input current Monitoring and Limiter

The two inputs (IIN1, IIN2) can be used to limit and monitor the Input current (Block A1 and A7 in [Figure 7](#)).

## Protection and Diagnostic Functions

The control loop reduces the Comp voltage when the voltage across the pins reaches Input Current Sense threshold  $V_{IIN1-IIN2}$  to keep the input current below  $I_{IN}Max$  [Equation \(10.9\)](#)

$$I_{IN}Max = \frac{V_{IIN1-IIN2}}{R_{IIN}} \quad (10.9)$$

The IINMON pin provides a linear indication of the current flowing through the input. The following [Equation \(10.10\)](#) is applicable:

$$V_{IINMON} = I_{IN} \cdot R_{IN} \cdot 20 \quad (10.10)$$

*Note: If the  $R_{IN}$  value is chosen in a way that the current limitation is much bigger than the nominal input current during the application the current measurement becomes inaccurate. Best results for an accurate current measurement via the  $V_{IINMON}$  pin is to set the current limit only slightly above the specific application related nominal input current.*

### 10.5 Output current Monitoring

The IOUTMON pin provides a linear indication of the current flowing through the LEDs. The following [Equation \(10.11\)](#) is applicable:

$$V_{IOUTMON} = 200 \text{ mV} + I_{OUT} \cdot R_{FB} \cdot 8 \quad (10.11)$$



### 10.6 Device Temperature Monitoring

A temperature sensor is integrated on the chip. The temperature monitoring circuit compares the measured temperature to the shutdown threshold.

If the internal temperature sensor reaches the shut-down temperature, the Gate Drivers plus the IVCC regulator are shut down as described in [Figure 28](#).

The CLKOUT function is disabled during an overtemperature event and will autorestart when the device cooled down and IVCC is present again.

*Note: The Device will start up with a soft start routine after a overtemperature condition disappear.*

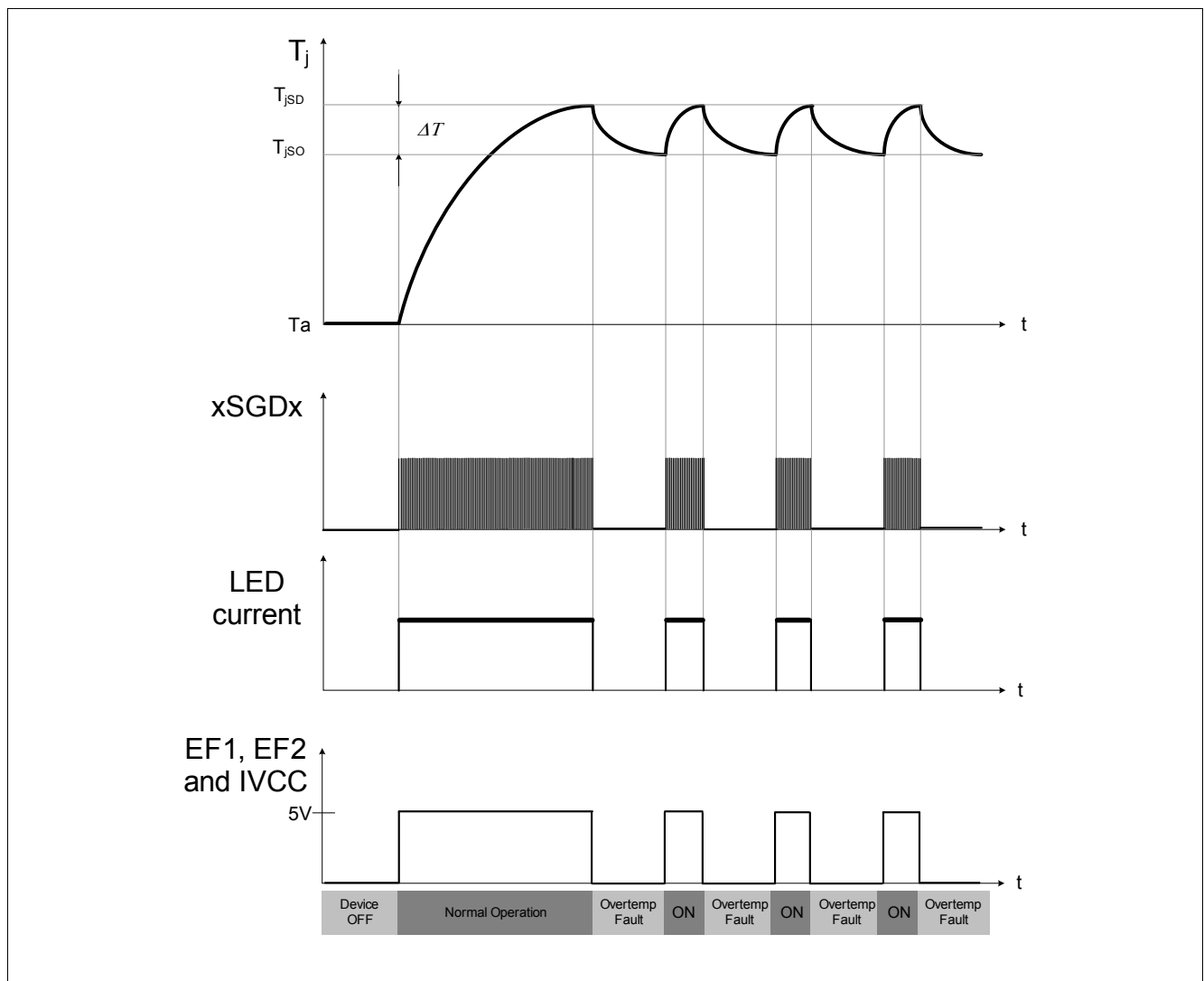

**Figure 28** Device Overtemperature Protection Behavior

Protection and Diagnostic Functions

10.7 Electrical Characteristics

Table 10 EC Protection and Diagnosis

$V_{IN} = 8\text{ V to }36\text{ V}$ ,  $T_J = -40^\circ\text{C to }+150^\circ\text{C}$ , all voltages with respect to AGND; (unless otherwise specified)

Parameter	Symbol	Values			Unit	Note or Test Condition	Number
		Min.	Typ.	Max.			
<b>Short Circuit Protection</b>							
Short to GND threshold	$V_{VFB\_S2G}$	0.53	0.563	0.59	V	$V_{VFB}$ decreasing;	P_10.8.1
<b>Temperature Protection:</b>							
Over Temperature Shutdown	$T_{j,SD}$	160	175	190	$^\circ\text{C}$	<sup>1)</sup>	P_10.8.4
Over Temperature Shutdown Hysteresis	$T_{j,SD,hyst}$	–	10	–	$^\circ\text{C}$	<sup>1)</sup>	P_10.8.5
<b>Overvoltage Protection:</b>							
VFB Over Voltage Feedback Threshold	$V_{VFB\_OVTH}$	1.42	1.46	1.50	V		P_10.8.6
Output Over Voltage Feedback Hysteresis	$V_{VFB\_OVTH,HYS}$	25	40	58	mV	Output Voltage decreasing;	P_10.8.7
<b>Open Load and Open Feedback Diagnostics</b>							
Open Load rising Threshold	$V_{VFB\_OL,rise}$	1.29	1.34	1.39	V	$V_{FBH-FBL} = 0\text{ V}$ ;	P_10.8.9
Open Load reference Voltage $V_{FBH-FBL}$	$V_{FBH-FBL\_OL}$	–	15	22.5	mV	$V_{FB} = 1.4\text{ V}$ ;	P_10.8.10
Open Load falling Threshold	$V_{VFB\_OL,fall}$	1.23	1.28	1.33	V	$V_{FBH-FBL} = 0\text{ V}$ ;	P_10.8.11
<b>Input Overvoltage protection</b>							
Input Overvoltage rising Threshold	$V_{INOVLOth}$	1.9	2	2.1	V	–	P_10.8.12
Input Overvoltage Threshold Hysteresis	$V_{INOVLO(hys)}$ t)	18	40	62	mV	–	P_10.8.13
<b>Error Flags</b>							
EF1,2 Pin Output Impedance	$R_{EF12}$	–	2.1	–	k $\Omega$	<sup>1)</sup> Fault Condition $I=100\mu\text{A}$	P_10.8.14

1) Specified by design; not subject to production test.

**Note:** *Integrated protection functions are designed to prevent IC destruction under fault conditions described in the datasheet. Fault conditions are considered as “outside” normal operating range. Protection functions are not designed for continuous repetitive operation.*

## 11 Infineon FLAT SPECTRUM Feature set

### 11.1 Description

The Infineon FLAT SPECTRUM feature set has the target to minimize external additional filter circuits. The goal is to provide several beneficial concepts to provide easy adjustments for EMC improvements after the layout is already done and the HW designed.

### 11.2 Synchronization Function

The TLD5190 features a SYNC input pin which can be used by a  $\mu\text{C}$  pin to define an oscillator switching frequency. The  $\mu\text{C}$  is responsible to synchronize with various devices by applying appropriate SYNC signals to the dedicated DC/DC devices in the system. Refer to [Figure 29](#)

*Note: The Synchronization function can not be used when the Spread Spectrum is active.*

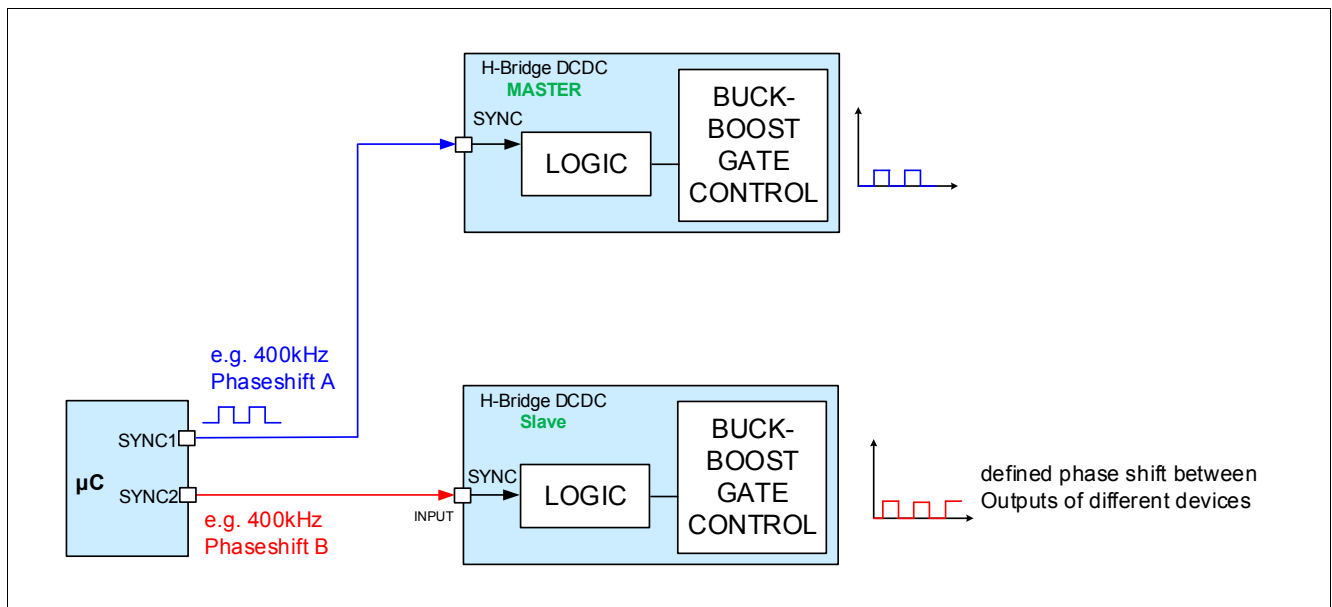

Figure 29 Synchronization Overview

### 11.3 CLKOUT Function

The CLKOUT pin provides an in-phase clock signal provided by the internal oscillator. This signal can be used to synchronize two devices for extending output power capability.

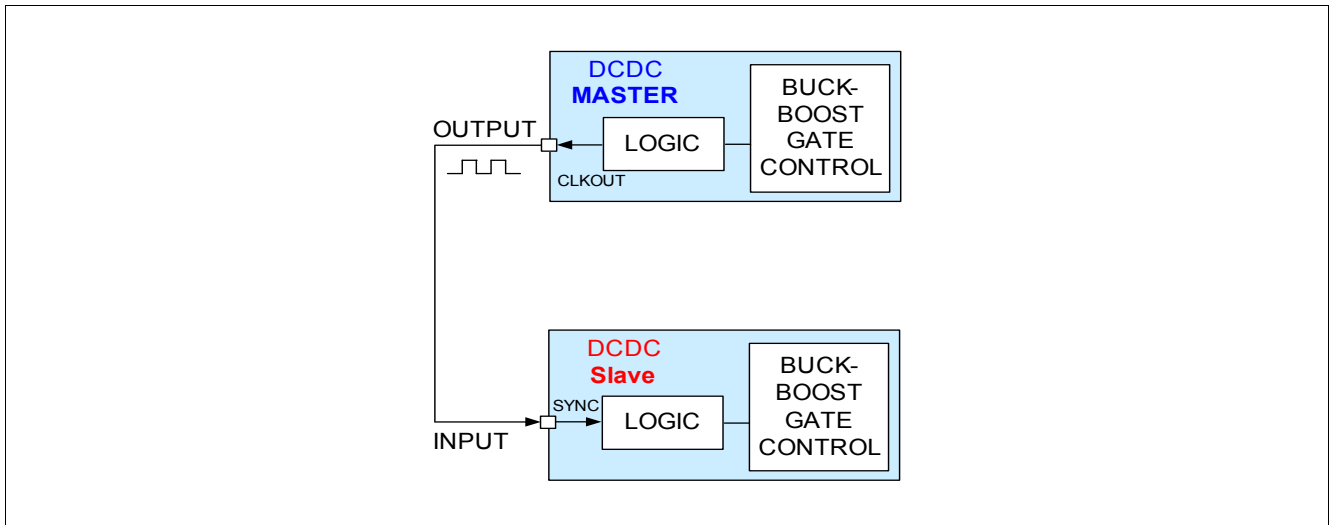

Figure 30 CLKOUT Overview

## 11.4 Spread Spectrum

The Spread Spectrum modulation technique significantly improves the lower frequency range of the spectrum ( $f < 30$  MHz).

By using the spread spectrum technique, it is possible to optimize the input filter only for the peak limits, and also pass the average limits (average emission limits are -20dB lower than the peak emission limits). By using spread spectrum, the need for low ESR input capacitors is relaxed because the input capacitor series resistor is important for the low frequency filter characteristic. This can be an economic benefit if there is a strong requirement for average limits.

The TLD5190 features a built in Spread Spectrum function which can be enabled via an external Pin ( $\text{SPREAD\_SPECTRUM} = \text{HIGH}$ ). The modulation frequency  $f_{FM}$ , P\_11.6.3 and the deviation frequency  $f_{dev}$ , P\_11.6.2 are internally fixed. Refer to [Figure 31](#) for more details.

*Note: The Spread Spectrum function can not be used when the synchronization pin is used.*

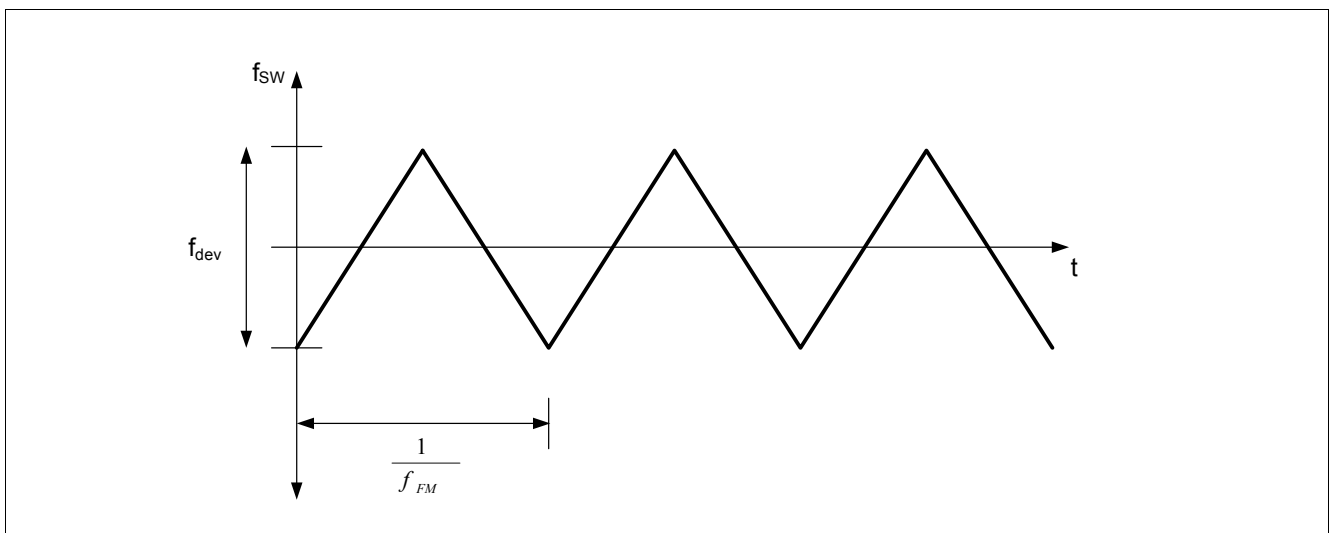
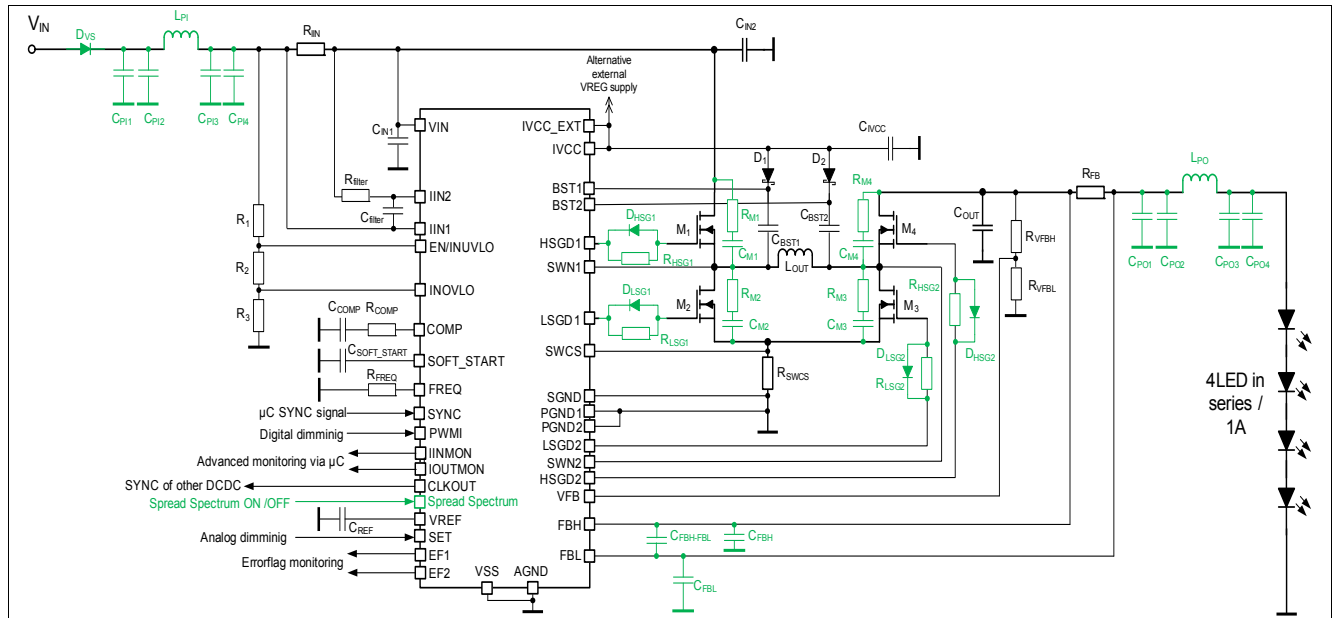

Figure 31 Spread Spectrum Overview

### 11.5 EMC optimized schematic

**Figure 32** below displays the Application circuit with additional external components for improved EMC behavior.



**Figure 32** Application Drawing Including Additional Components for an Improved EMC Behavior

*Note: The following information is given as a hint for the implementation of the device only and shall not be regarded as a description or warranty of a certain functionality, condition or quality of the device.*

## 11.6 Electrical Characteristics

**Table 11 EC Spread Spectrum**

$V_{IN} = 8\text{ V to }36\text{ V}$ ,  $T_J = -40^\circ\text{C to }+150^\circ\text{C}$ , all voltages with respect to AGND; (unless otherwise specified)

Parameter	Symbol	Values			Unit	Note or Test Condition	Number
		Min.	Typ.	Max.			
<b>Spread Spectrum Parameters</b>							
Frequency Deviation	$f_{dev}$	–	±16	–	%	1) SPREAD_SPECTRUM = HIGH;;	P_11.6.2
Frequency Modulation	$f_{FM}$	–	12	–	kHz	1) SPREAD_SPECTRUM = HIGH;	P_11.6.3
<b>Input Characteristics (SPREAD_SPECTRUM)</b>							
SPREAD_SPECTRUM Turn On Threshold	$V_{SPREAD\_SPECTRUM,ON}$	2	–	–	V	–	P_11.6.5
SPREAD_SPECTRUM Turn Off Threshold	$V_{SPREAD\_SPECTRUM,OFF}$	–	–	0.8	V	–	P_11.6.6
SPREAD_SPECTRUM High Input Current	$I_{SPREAD\_SPECTRUM,H}$	15	30	45	μA	$V_{SPREAD\_SPECTRUM} = 2.0\text{ V};$	P_11.6.8
SPREAD_SPECTRUM Low Input Current	$I_{SPREAD\_SPECTRUM,L}$	6	12	18	μA	$V_{SPREAD\_SPECTRUM} = 0.8\text{ V};$	P_11.6.9
<b>Output Characteristics (CLKOUT)</b>							
L level output voltage	$V_{CLKOUT(L)}$	0	–	0.4	V	$I_{CLKOUT} = -2\text{ mA};$	P_11.6.10
H level output voltage	$V_{CLKOUT(H)}$	$V_{VCC} - 0.4\text{ V}$	–	$V_{VCC}$	V	$I_{CLKOUT} = 2\text{ mA};$	P_11.6.11

1) Specified by design; not subject to production test.

## 12 Application Information

*Note:* The following information is given as a hint for the implementation of the device only and shall not be regarded as a description or warranty of a certain functionality, condition or quality of the device.

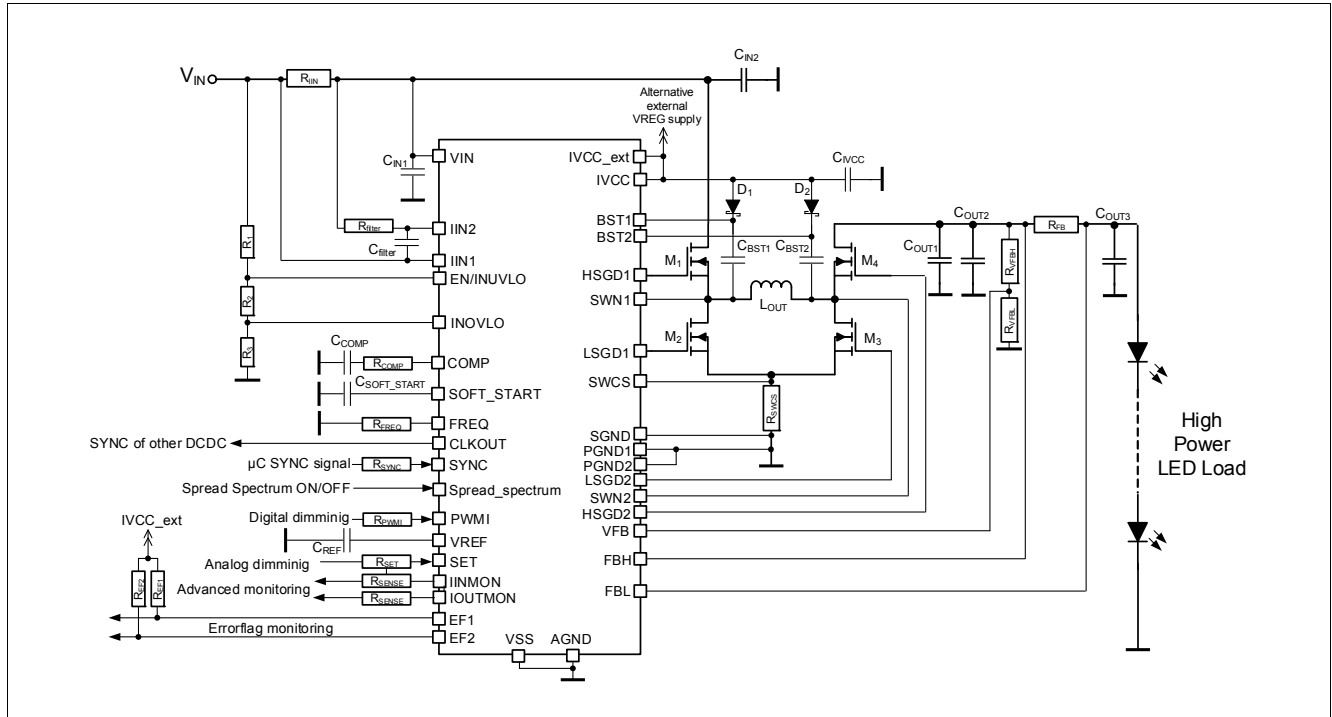

**Figure 33** Application Drawing - TLD5190 as current regulator

**Table 12** BOM - TLD5190 as current regulator ( $I_{OUT} = 1\text{ A}$ ,  $f_{SW} = 300\text{ kHz}$ )

Reference Designator	Value	Manufacturer	Part Number	Type
$D_1, D_2$	BAT46WJ	--	BAT46WJ	Diode
$C_{IN1}$	1 $\mu\text{F}$ , 100 V	TDK	X7R	Capacitor
$C_{IN2}$	4.7 $\mu\text{F}$ , 100 V	TDK	X7R	Capacitor
$C_{filter}$	470 nF, 6.3 V	TDK	X7R	Capacitor
$C_{COMP}$	22 nF, 16 V	TDK	X7R	Capacitor
$C_{SOFT\_START}$	22 nF, 16 V	TDK	X7R	Capacitor
$C_{OUT1}$	4.7 $\mu\text{F}$ , 100 V	TDK	X7R	Capacitor
$C_{OUT2}, C_{OUT3}, C_{REF}$	100 nF, 100 V	TDK	X7R	Capacitor
$C_{IV}$	10 $\mu\text{F}$ , 10 V	TDK	X7R	Capacitor
$C_{BST1}, C_{BST2}$	100 nF, 16 V	TDK	X7R	Capacitor
$IC_1$	--	Infineon	TLD5190	IC
$L_{OUT}$	10 $\mu\text{H}$	Coilcraft	XAL1010-103MEC	Inductor
$R_{filter}$	50 $\Omega$ , 1%	Panasonic	--	Resistor
$R_{FB}$	0.150 $\Omega$ , 1%	Panasonic	--	Resistor
$R_{IN}$	0.003 $\Omega$ , 1%	Panasonic	--	Resistor



Application Information

Table 12 BOM - TLD5190 as current regulator ( $I_{OUT} = 1\text{ A}$ ,  $f_{SW} = 300\text{ kHz}$ )

Reference Designator	Value	Manufacturer	Part Number	Type
$R_1, R_2, R_3, R_{EN}, R_{PWM1}, R_{Sense1}, R_{Sense2}, R_{SYNC}, R_{EF1}, R_{EF2}, R_{SET}$	XX k $\Omega$ , 1%	Panasonic	--	Resistor
$R_{VFB1}, R_{VFBH}$	1.5 k $\Omega$ , 56 k $\Omega$ , 1%	Panasonic	--	Resistor
$R_{COMP}$	0 $\Omega$	Panasonic	--	Resistor
$R_{FREQ}$	37.4 k $\Omega$ , 1%	Panasonic	--	Resistor
$R_{SWCS}$	0.005 $\Omega$ , 1%	Panasonic	ERJB1CFRO5U	Resistor
$M_1, M_2, M_3, M_4$	Dual MOSFET: 100 V / 35 m $\Omega$ , N-ch	Infineon	IPG20N10S4L-35	Transistor

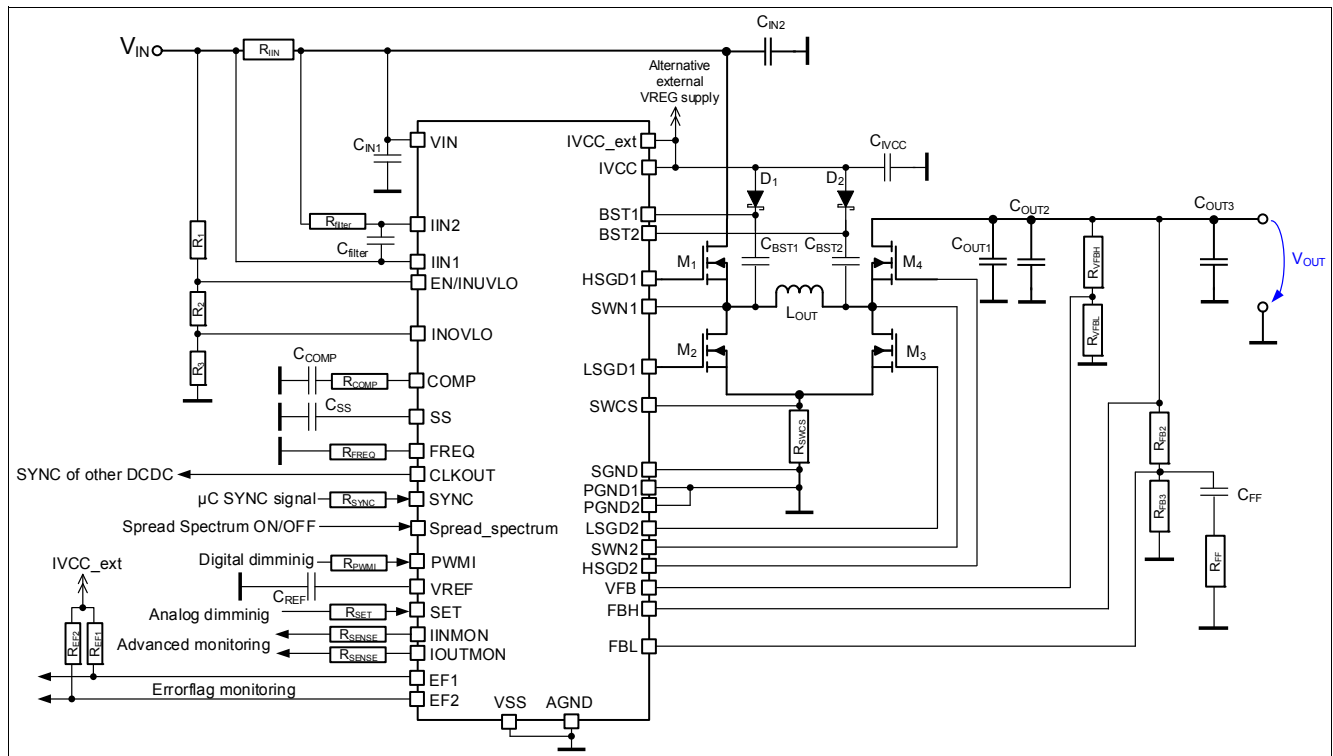

Figure 34 Application Drawing - TLD5190 as 10V voltage regulator

Table 13 BOM - TLD5190 as voltage regulator ( $I_{OUT} = 1\text{ A}$ ,  $f_{SW} = 300\text{ kHz}$ )

Reference Designator	Value	Manufacturer	Part Number	Type
$D_1, D_2$	BAT46WJ	--	BAT46WJ	Diode
$C_{IN1}$	1 $\mu\text{F}$ , 100 V	TDK	X7R	Capacitor
$C_{IN2}$	4.7 $\mu\text{F}$ , 100 V	TDK	X7R	Capacitor
$C_{filter}$	470 nF, 6.3 V	TDK	X7R	Capacitor
$C_{COMP}$	22 nF, 16 V	TDK	X7R	Capacitor
$C_{FF}$	10 nF, 50 V	TDK	X7R	Capacitor
$C_{SOFT\_START}$	22 nF, 16 V	TDK	X7R	Capacitor
$C_{OUT1}$	4.7 $\mu\text{F}$ , 100 V	TDK	X7R	Capacitor

Application Information

Table 13 BOM - TLD5190 as voltage regulator ( $I_{OUT} = 1\text{ A}$ ,  $f_{SW} = 300\text{ kHz}$ )

Reference Designator	Value	Manufacturer	Part Number	Type
$C_{OUT2}, C_{OUT3}, C_{REF}$	100 nF, 100 V	TDK	X7R	Capacitor
$C_{IVCC}$	10 $\mu\text{F}$ , 10 V	TDK	X7R	Capacitor
$C_{BST1}, C_{BST2}$	100 nF, 16 V	TDK	X7R	Capacitor
$IC_1$	--	Infineon	TLD5190	IC
$L_{OUT}$	10 $\mu\text{H}$	Coilcraft	XAL1010-103MEC	Inductor
$R_{filter}$	50 $\Omega$ , 1%	Panasonic	--	Resistor
$R_{FB2}, R_{FB3}$	150 $\Omega$ , 10.1k $\Omega$ , 1%	Panasonic	--	Resistor
$R_{FF}$	1.5 k $\Omega$ , 1%	Panasonic	--	Resistor
$R_{IN}$	0.003 $\Omega$ , 1%	Panasonic	--	Resistor
$R_1, R_2, R_3, R_{EN}, R_{PWM1}, R_{Sense1}, R_{Sense2}, R_{SYNC}, R_{EF1}, R_{EF2}, R_{SET}$	XX k $\Omega$ , 1%	Panasonic	--	Resistor
$R_{VFBL}, R_{VFBH}$	1.5 k $\Omega$ , 56 k $\Omega$ , 1%	Panasonic	--	Resistor
$R_{COMP}$	0 $\Omega$	Panasonic	--	Resistor
$R_{FREQ}$	37.4 k $\Omega$ , 1%	Panasonic	--	Resistor
$R_{SWCS}$	0.005 $\Omega$ , 1%	Panasonic	ERJB1CFRO5U	Resistor
$M_1, M_2, M_3, M_4$	Dual MOSFET: 100 V / 35 m $\Omega$ , N-ch	Infineon	IPG20N10S4L-35	Transistor

## 12.1 Further Application Information

### Typical Performance Characteristics of Device

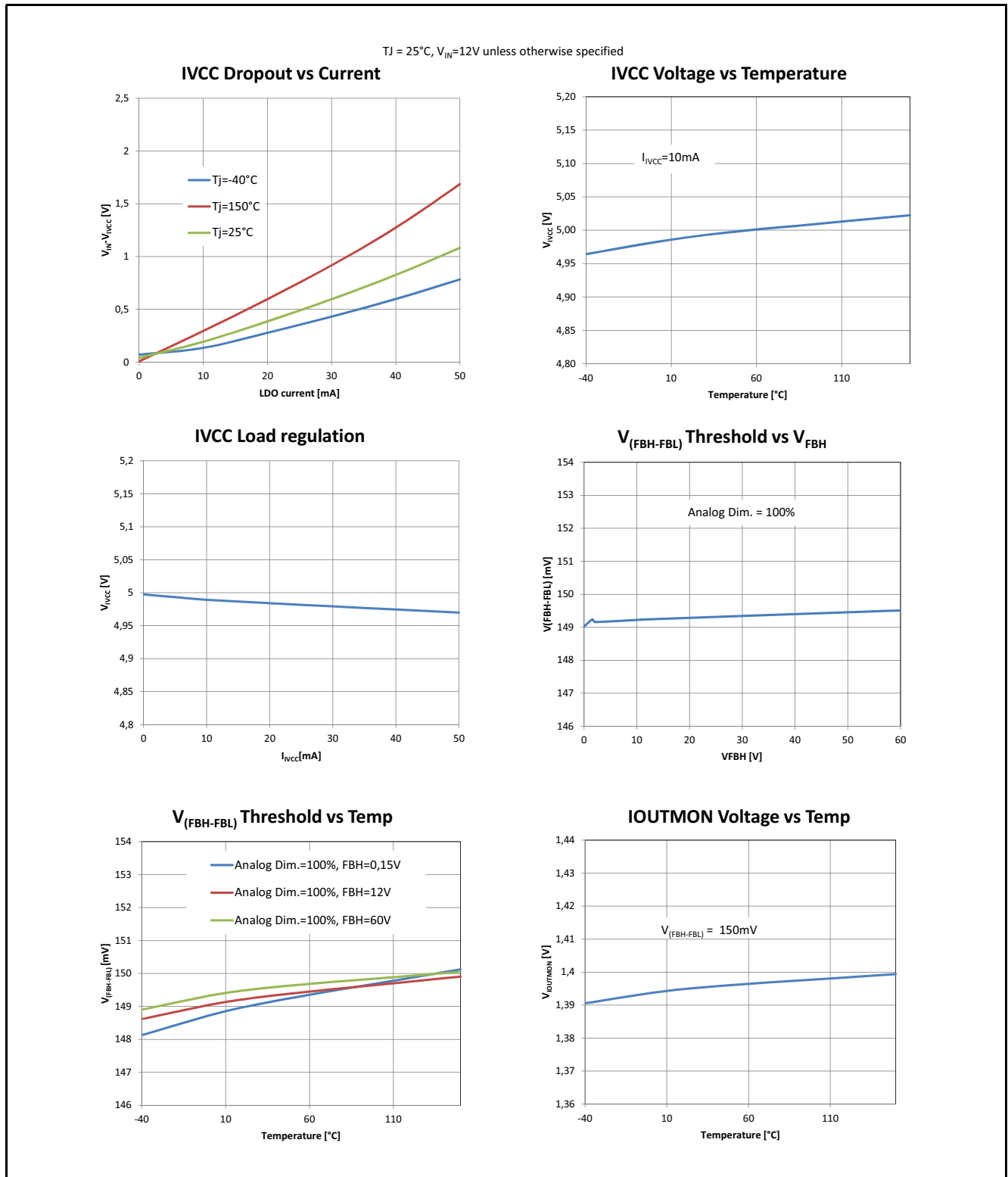

Figure 35 Characterization Diagrams 1

Application Information

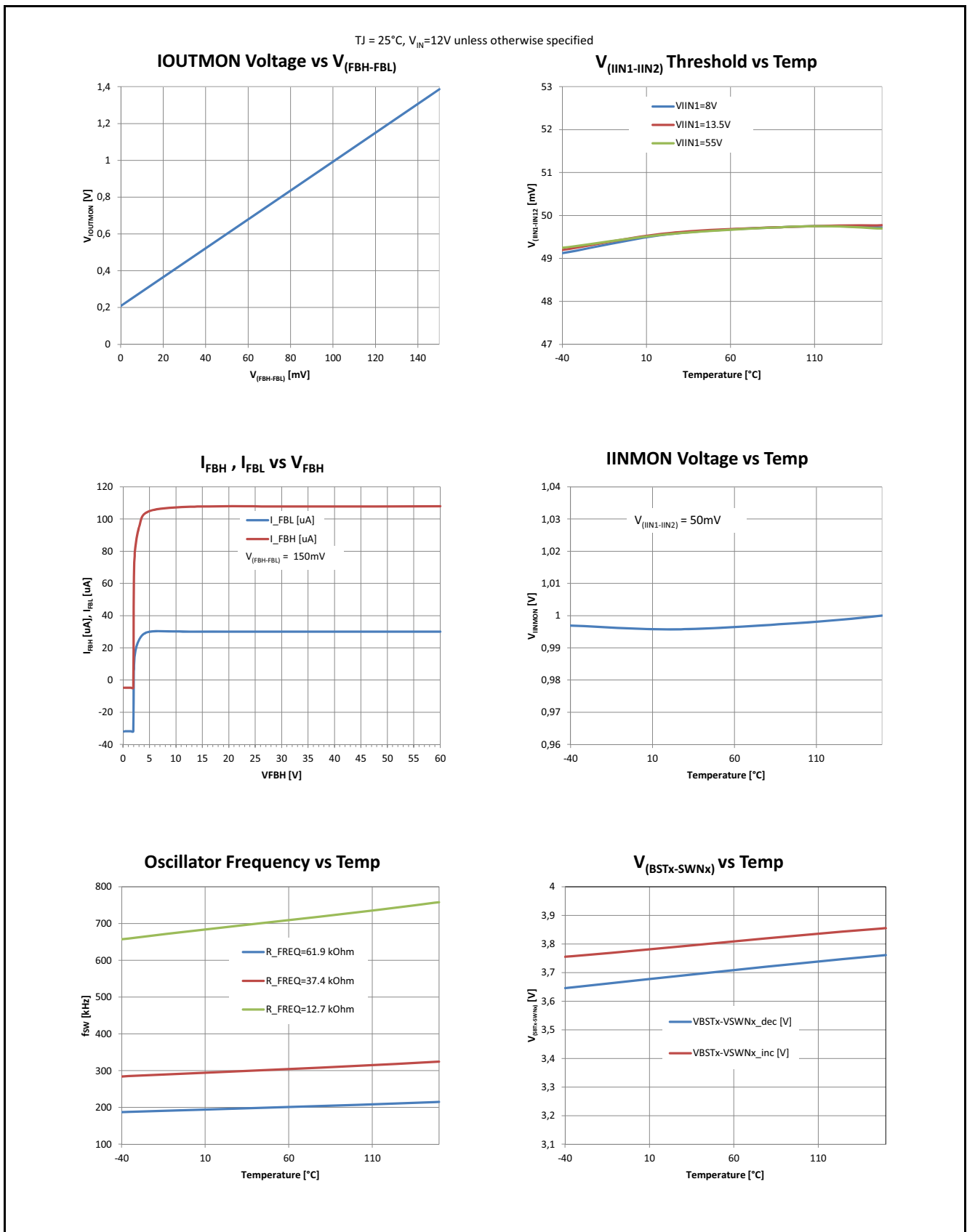

Figure 36 Characterization Diagrams 2

Application Information

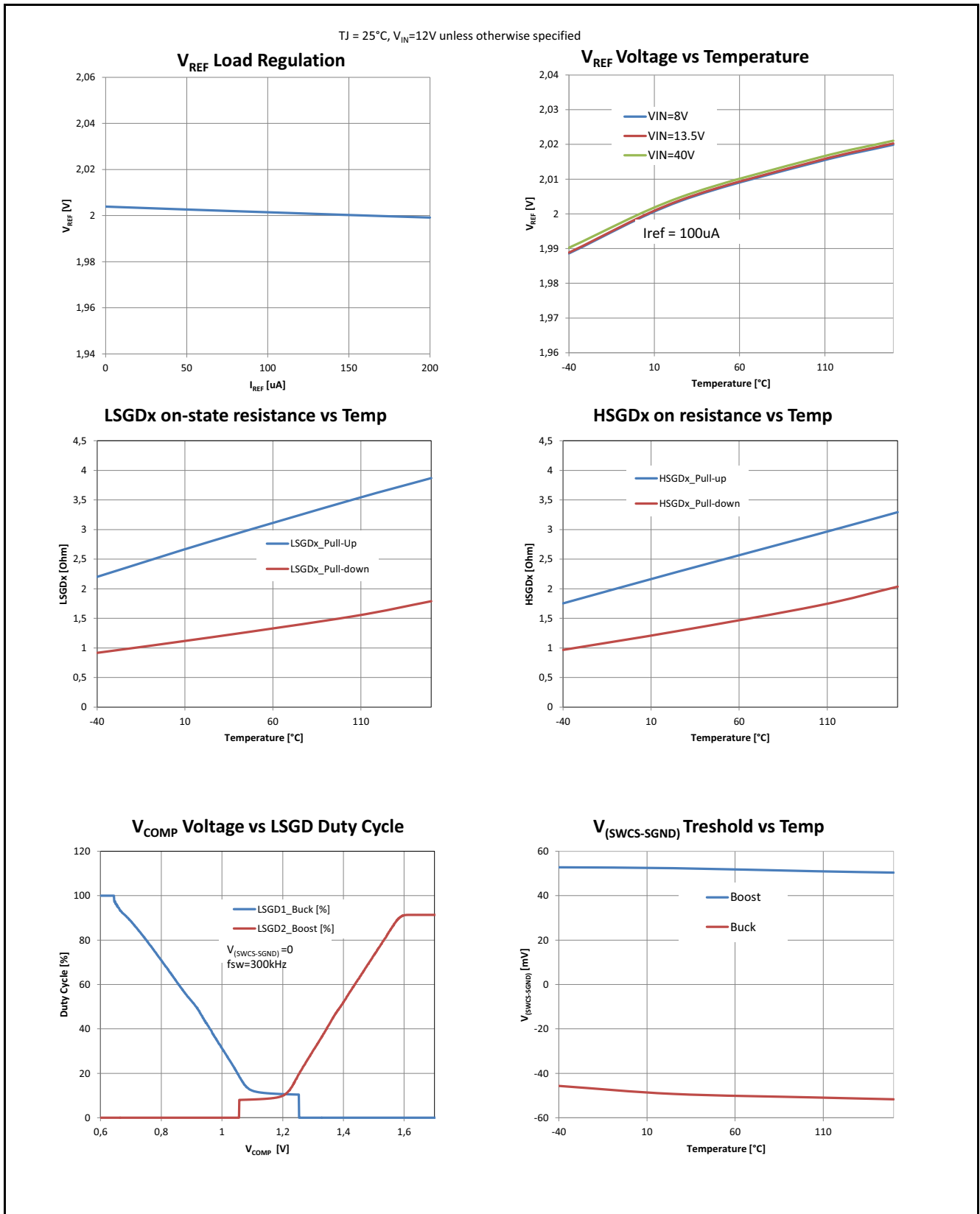

Figure 37 Characterization Diagrams 3

- For further information you may contact <http://www.infineon.com/>



Package Outlines

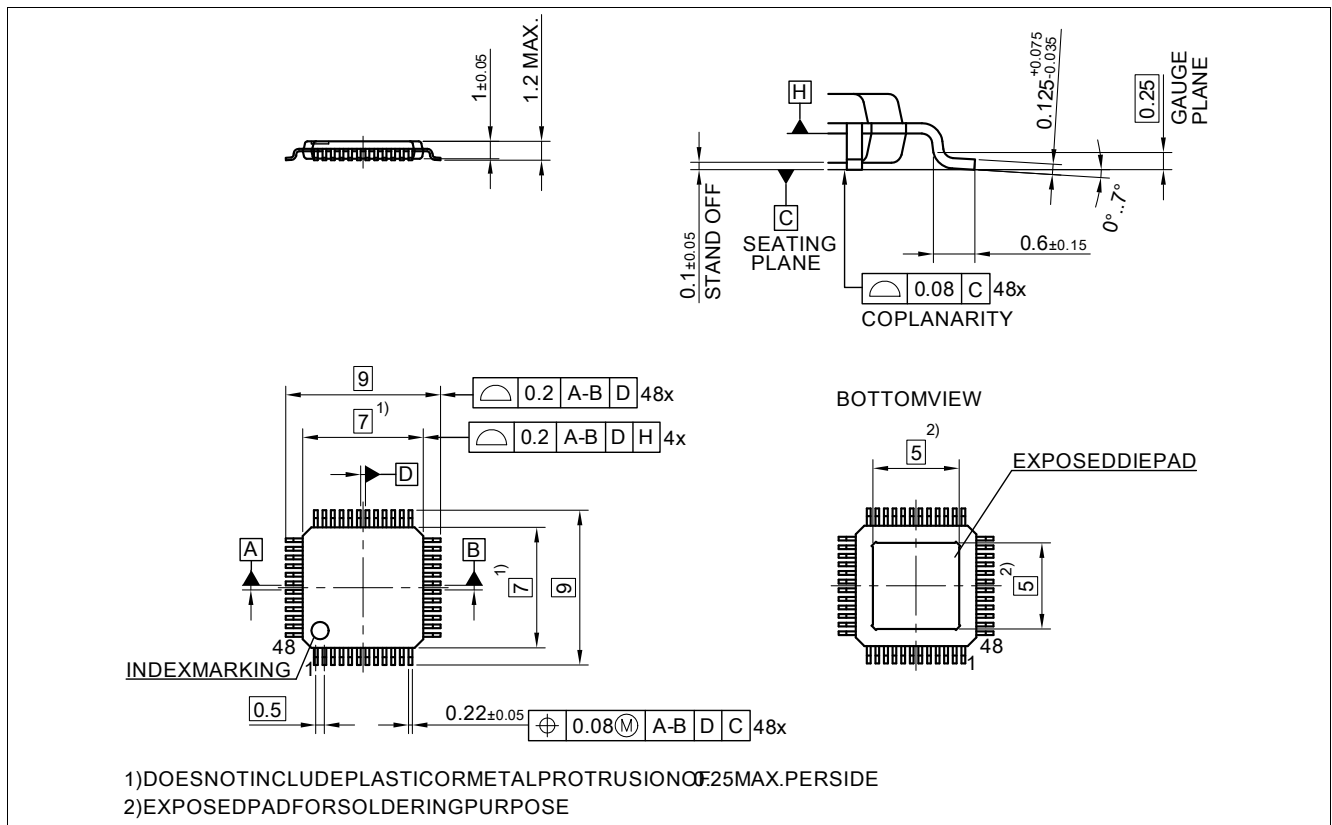

Figure 39 PG-TQFP-48-9

**Green Product (RoHS compliant)**

To meet the world-wide customer requirements for environmentally friendly products and to be compliant with government regulations the device is available as a green product. Green products are RoHS-Compliant (i.e Pb free finish on leads and suitable for Pb-free soldering according to IPC/JEDEC J-STD-020).

Revision History

## 14 Revision History

Revision	Date	Changes
Rev. 1.0	2016-05-20	Released Datasheet
Rev. 1.1	2018-02-08	Added: CCM on regulator description <a href="#">Chapter 6.1</a>
Rev. 1.1	2018-02-08	Added TQFP package
Rev. 1.1	2018-02-08	Corrected graph $V_{COMP}$ vs DUTY
Rev. 1.1	2018-02-08	Corrected soft start behavior <a href="#">Chapter 6.2</a> “if an open load”
Rev. 1.1	2018-02-08	Divided In and out overvoltage protection def. <a href="#">Chapter 10.2</a> <a href="#">Chapter 10.3</a>
Rev. 1.1	2018-02-08	Removed “Flex” from Family name. <a href="#">Chapter 1</a>
Rev. 1.1	2018-02-08	Specified Complessive gain of error amp <a href="#">Chapter 6.1</a>
Rev. 1.1	2018-02-08	Improved description of soft start <a href="#">Chapter 6.2</a>
Rev. 1.1	2018-02-08	Added Soft Start mask in the Short circuit description <a href="#">Chapter 10.2</a>
Rev. 1.1	2018-02-08	Added input current limiter description <a href="#">Chapter 10.4</a>
Rev. 1.1	2018-02-08	Removed Parameter 6.4.2 covered now by updated 6.4.1 <a href="#">Chapter 6.6</a>



## Table of Content

<b>1</b>	<b>Overview</b> .....	<b>1</b>
<b>2</b>	<b>Block Diagram</b> .....	<b>3</b>
<b>3</b>	<b>Pin Configuration</b> .....	<b>4</b>
3.1	Pin Assignment .....	4
3.2	Pin Definitions and Functions .....	5
<b>4</b>	<b>General Product Characteristics</b> .....	<b>8</b>
4.1	Absolute Maximum Ratings .....	8
4.2	Functional Range .....	10
4.3	Thermal Resistance .....	10
<b>5</b>	<b>Power Supply</b> .....	<b>12</b>
5.1	Different Power States .....	14
5.2	Electrical Characteristics .....	15
<b>6</b>	<b>Regulator Description</b> .....	<b>16</b>
6.1	Regulator Diagram Description .....	16
6.2	Adjustable Soft Start Ramp .....	18
6.3	Switching Frequency setup .....	19
6.4	Operation of 4 switches H-Bridge architecture .....	20
6.4.1	Boost mode ( $V_{IN} < V_{OUT}$ ) .....	20
6.4.2	Buck mode ( $V_{IN} > V_{OUT}$ ) .....	21
6.4.3	Buck-Boost mode ( $V_{IN} \sim V_{OUT}$ ) .....	22
6.5	Flexible current sense .....	23
6.6	Programming Output Voltage (Constant Voltage Regulation) .....	24
6.7	Electrical Characteristics .....	25
<b>7</b>	<b>Digital Dimming Function</b> .....	<b>28</b>
7.1	Description .....	28
7.2	Electrical Characteristics .....	30
<b>8</b>	<b>Analog Dimming</b> .....	<b>31</b>
8.1	Description .....	31
8.2	Electrical Characteristics .....	32
<b>9</b>	<b>Linear Regulator</b> .....	<b>34</b>
9.1	IVCC Description .....	34
9.2	Electrical Characteristics .....	35
<b>10</b>	<b>Protection and Diagnostic Functions</b> .....	<b>36</b>
10.1	Description .....	36
10.2	Output Overvoltage, Open Load, Short circuit protection .....	37
10.2.1	Short Circuit protection .....	37
10.2.2	Overvoltage Protection .....	37
10.2.3	Open Load Protection .....	38
10.3	Input voltage monitoring, protection and power derating .....	38
10.4	Input current Monitoring and Limiter .....	39
10.5	Output current Monitoring .....	40
10.6	Device Temperature Monitoring .....	41
10.7	Electrical Characteristics .....	42
<b>11</b>	<b>Infineon FLAT SPECTRUM Feature set</b> .....	<b>43</b>
11.1	Description .....	43

11.2	Synchronization Function .....	43
11.3	CLKOUT Function .....	43
11.4	Spread Spectrum .....	45
11.5	EMC optimized schematic .....	46
11.6	Electrical Characteristics .....	47
<b>12</b>	<b>Application Information .....</b>	<b>48</b>
12.1	Further Application Information .....	51
<b>13</b>	<b>Package Outlines .....</b>	<b>54</b>
<b>14</b>	<b>Revision History .....</b>	<b>56</b>
	<b>Table of Content .....</b>	<b>57</b>

#### Trademarks of Infineon Technologies AG

$\mu$ HVIC™,  $\mu$ IPM™,  $\mu$ PFC™, AU-ConvertIR™, AURIX™, C166™, CanPAK™, CIPOS™, CIPURSE™, CoolDP™, CoolGaN™, COOLiR™, CoolMOS™, CoolSET™, CoolSiC™, DAVE™, DI-POL™, DirectFET™, DrBlade™, EasyPIM™, EconoBRIDGE™, EconoDUAL™, EconoPACK™, EconoPIM™, EiceDRIVER™, eupec™, FCOS™, GaNpowIR™, HEXFET™, HITFET™, HybridPACK™, iMOTION™, IRAM™, ISOFACE™, IsoPACK™, LEDriviR™, LITIX™, MIPAQ™, ModSTACK™, my-d™, NovalithIC™, OPTIGA™, OptiMOS™, ORIGA™, PowIRaudio™, PowIRstage™, PrimePACK™, PrimeSTACK™, PROFET™, PRO-SIL™, RASIC™, REAL3™, SmartLEWIS™, SOLID FLASH™, SPOC™, StrongIRFET™, SupIRBuck™, TEMPFET™, TRENCHSTOP™, TriCore™, UHVIC™, XHP™, XMC™.

Trademarks updated November 2015

#### Other Trademarks

All referenced product or service names and trademarks are the property of their respective owners.

**Edition 2018-02-08**

**Published by**

**Infineon Technologies AG**

**81726 Munich, Germany**

**© 2018 Infineon Technologies AG.**

**All Rights Reserved.**

**Do you have a question about any aspect of this document?**

**Email: [erratum@infineon.com](mailto:erratum@infineon.com)**

**Document reference (doc\_number)**

#### IMPORTANT NOTICE

The information given in this document shall in no event be regarded as a guarantee of conditions or characteristics ("Beschaffheitsgarantie").

With respect to any examples, hints or any typical values stated herein and/or any information regarding the application of the product, Infineon Technologies hereby disclaims any and all warranties and liabilities of any kind, including without limitation warranties of non-infringement of intellectual property rights of any third party.

In addition, any information given in this document is subject to customer's compliance with its obligations stated in this document and any applicable legal requirements, norms and standards concerning customer's products and any use of the product of Infineon Technologies in customer's applications.

The data contained in this document is exclusively intended for technically trained staff. It is the responsibility of customer's technical departments to evaluate the suitability of the product for the intended application and the completeness of the product information given in this document with respect to such application.

For further information on technology, delivery terms and conditions and prices, please contact the nearest Infineon Technologies Office ([www.infineon.com](http://www.infineon.com)).

#### WARNINGS

Due to technical requirements products may contain dangerous substances. For information on the types in question please contact your nearest Infineon Technologies office.

Except as otherwise explicitly approved by Infineon Technologies in a written document signed by authorized representatives of Infineon Technologies, Infineon Technologies' products may not be used in any applications where a failure of the product or any consequences of the use thereof can reasonably be expected to result in personal injury.

## X-ON Electronics

Largest Supplier of Electrical and Electronic Components

*Click to view similar products for [LED Lighting Drivers](#) category:*

*Click to view products by [Infineon](#) manufacturer:*

Other Similar products are found below :

[LV5235V-MPB-H](#) [AP5726WUG-7](#) [IS31BL3228B-UTLS2-TR](#) [IS31BL3506B-TTLS2-TR](#) [AP5725FDCG-7](#) [AP5726FDCG-7](#) [SLG7NT4082V](#)  
[SLG7NT4082VTR](#) [AP5725WUG-7](#) [BD1604MVV-E2](#) [MAX16840ATB+](#) [CAT4004BHU2-GT3](#) [TLE4242EJ](#) [IS31LT3172-GRLS4-TR](#)  
[IS32LT3174-GRLA3-TR](#) [ZXLD1374QESTTC](#) [NCV78825DQ0R2G](#) [MP4425AGQB-P](#) [MP3367GR-P](#) [MPQ3369GR-P](#) [MPQ7220GF-AEC1-P](#)  
[MP3362GJ-Z](#) [DIO5662ST6](#) [IS31BL3508A-TTLS2-TR](#) [DIO5661TST6](#) [NJW4617DL3-TE1](#) [BD2802GU-E2](#) [BD6583MUV-E2](#)  
[NCV7693DB0R2G](#) [LV52207NXA-VH](#) [NCL30076AADR2G](#) [NCL30486B2DR2G](#) [NCL30488B4DR2G](#) [NCV78763MW4AR2G](#)  
[BD18353EFV-ME2](#) [A6217KLJTR-T](#) [LT3761EMSE#TRPBF](#) [TLD2132-1EP](#) [TLD2331-3EP](#) [MPM6010GQV-AEC1-Z](#) [MPQ4425MGQB-](#)  
[AEC1-Z](#) [MPQ3326GR-AEC1-Z](#) [MPQ7230GLE-AEC1-Z](#) [MP2341GTL-Z](#) [BCR602](#) [IS31FL3236-TQLS2-TR](#) [TLD700216ESXUMA1](#)  
[LM3405AXMYX/NOPB](#) [LM36273YFFR](#) [MP46885DN-LF-Z](#)