

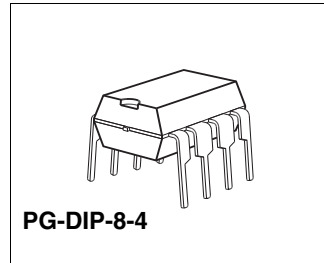

1 Overview

1.1 Features

- Optimized for headlight beam control applications
- Delivers up to 0.8 A
- Low saturation voltage;
typ. 1.2 V total @ 25 °C; 0.4 A
- Output protected against short circuit
- Overtemperature protection with hysteresis
- Over- and undervoltage lockout
- No crossover current
- Internal clamp diodes
- Green Product (RoHS compliant)
- AEC Qualified



1.2 Description

The TLE 4209A is a protected H-Bridge Driver designed specifically for automotive headlight beam control and industrial servo control applications.

The part is built using Infineons bipolar high voltage power technology DOPL.

The device is available in a PG-DIP-8-4 package.

The servo-loop-parameter pos.- and neg. Hysteresis, pos.- and neg. deadband and angle-amplification are programmable with external resistors.

An internal window-comparator controls the input line. In the case of a fault condition, like short circuit to GND, short circuit to supply-voltage, and broken wire, the TLE 4209A stops the motor immediately (brake condition).

Furthermore the built in features like over- and undervoltage-lockout, short-circuit-protection and over-temperature-protection will open a wide range of automotive- and industrial applications.

Type	Package
TLE 4209A	PG-DIP-8-4

1.3 Pin Definitions and Functions

Pin No. PG-DIP-8-4	Symbol	Function
1	FB	Feedback Input
2	HYST	Hysteresis I/O
3	OUT1	Power Output 1
4	V_S	Power Supply Voltage
5	OUT2	Power Output 2
6	GND	Ground
7	RANGE	Range Input
8	REF	Reference Input

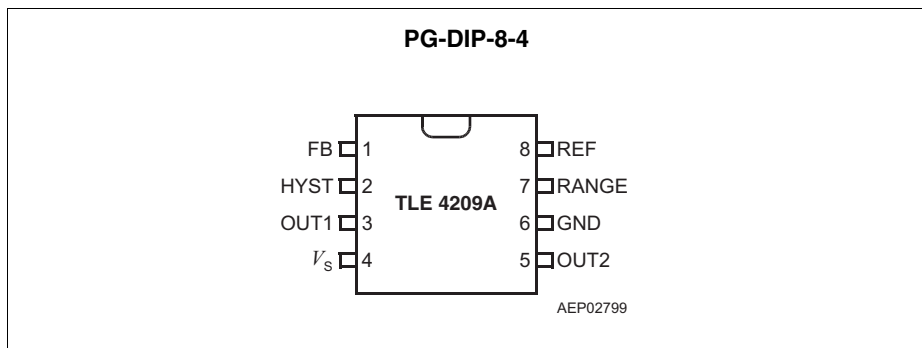

Figure 1 Pin Configuration
(top view)

1.4 Functional Block Diagram

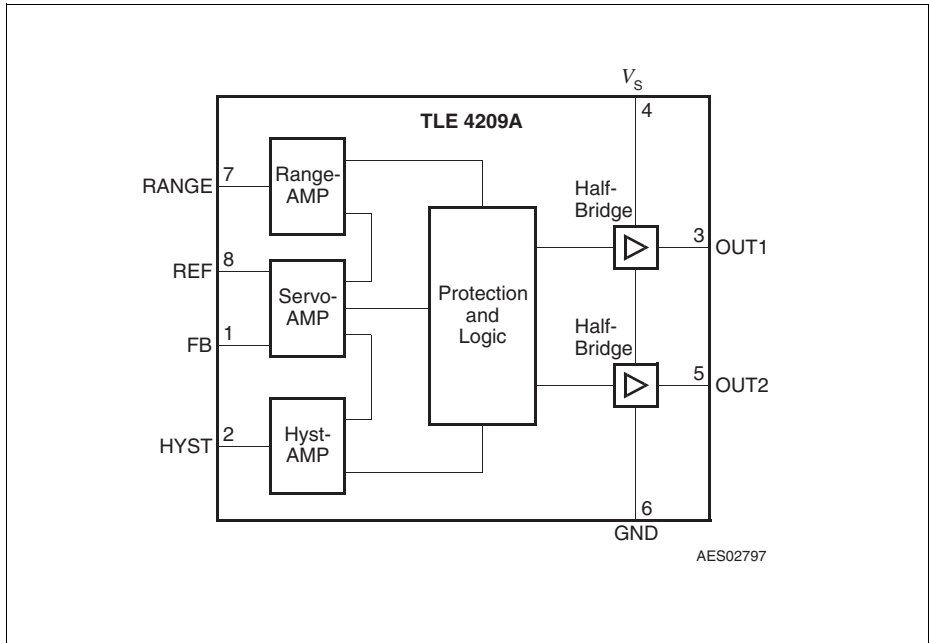

Figure 2 Block Diagram

1.5 Absolute Maximum Ratings

Parameter	Symbol	Limit Values		Unit	Remarks
		min.	max.		

Voltages

Supply voltage	V_S	- 0.3	45	V	-
Supply voltage	V_S	- 1	-	V	$t < 0.5 \text{ s}; I_S > - 2 \text{ A}$
Logic input voltages (FB, REF, RANGE, HYST)	V_I	- 0.3	20	V	-

Currents

Output current (OUT1, OUT2)	I_{OUT}	-	-	A	internally limited
Output current (Diode)	I_{OUT}	- 1	1	A	-
Input current (FB, REF, RANGE, HYST)	I_{IN}	- 2 - 6	2 6	mA mA	$t < 2 \text{ ms}; t/T < 0.1$

Temperatures

Junction temperature	T_j	- 40	150	°C	-
Storage temperature	T_{stg}	- 50	150	°C	-

Thermal Resistances

Junction ambient (PG-DIP-8-4)	R_{thjA}		100	K/W	-
-------------------------------	------------	--	-----	-----	---

Note: Stresses above those listed here may cause permanent damage to the device. Exposure to absolute maximum rating conditions for extended periods may affect device reliability.

1.6 Operating Range

Parameter	Symbol	Limit Values		Unit	Remarks
		min.	max.		
Supply voltage	V_S	8	18	V	After V_S rising above $V_{UV\ ON}$
Supply voltage increasing	V_S	- 0.3	$V_{UV\ ON}$	V	Outputs in tristate
Supply voltage decreasing	V_S	- 0.3	$V_{UV\ OFF}$	V	Outputs in tristate
Output current	I_{OUT1-2}	- 0.8	0.8	A	-
Input current (FB, REF)	I_{IN}	- 50	500	μ A	-
Junction temperature	T_j	- 40	150	$^{\circ}$ C	-

Note: In the operating range, the functions given in the circuit description are fulfilled.

1.7 Electrical Characteristics

$8\text{ V} < V_S < 18\text{ V}$; $I_{OUT1-2} = 0\text{ A}$; $-40\text{ }^{\circ}\text{C} < T_j < 150\text{ }^{\circ}\text{C}$ (unless otherwise specified)

Parameter	Symbol	Limit Values			Unit	Test Condition
		min.	typ.	max.		

Current Consumption

Supply current	I_S	-	12	20	mA	-
Supply current	I_S	-	20	30	mA	$I_{OUT1} = 0.4\text{ A}$ $I_{OUT2} = -0.4\text{ A}$
Supply current	I_S	-	30	50	mA	$I_{OUT1} = 0.8\text{ A}$ $I_{OUT2} = -0.8\text{ A}$

Over- and Under Voltage Lockout

UV Switch ON voltage	$V_{UV\ ON}$	-	7.4	8	V	V_S increasing
UV Switch OFF voltage	$V_{UV\ OFF}$	6.3	6.9	-	V	V_S decreasing
UV ON/OFF Hysteresis	V_{UVHY}	-	0.5	-	V	$V_{UV\ ON} - V_{UV\ OFF}$
OV Switch OFF voltage	$V_{OV\ OFF}$	-	20.5	23	V	V_S increasing
OV Switch ON voltage	$V_{OV\ ON}$	17.5	20	-	V	V_S decreasing
OV ON/OFF Hysteresis	V_{OVHY}	-	0.5	-	V	$V_{OV\ OFF} - V_{OV\ ON}$

1.7 Electrical Characteristics (cont'd)
 $8\text{ V} < V_S < 18\text{ V}; I_{\text{OUT}1-2} = 0\text{ A}; -40\text{ }^\circ\text{C} < T_j < 150\text{ }^\circ\text{C}$ (unless otherwise specified)

Parameter	Symbol	Limit Values			Unit	Test Condition
		min.	typ.	max.		

Outputs OUT1-2
Saturation Voltages

Source (upper) $I_{\text{OUT}} = -0.2\text{ A}$	$V_{\text{SAT U}}$	–	0.85	1.15	V	$T_j = 25\text{ }^\circ\text{C}$
Source (upper) $I_{\text{OUT}} = -0.4\text{ A}$	$V_{\text{SAT U}}$	–	0.90	1.20	V	$T_j = 25\text{ }^\circ\text{C}$
Sink (upper) $I_{\text{OUT}} = -0.8\text{ A}$	$V_{\text{SAT U}}$	–	1.10	1.50	V	$T_j = 25\text{ }^\circ\text{C}$
Sink (lower) $I_{\text{OUT}} = 0.2\text{ A}$	$V_{\text{SAT L}}$	–	0.15	0.23	V	$T_j = 25\text{ }^\circ\text{C}$
Sink (lower) $I_{\text{OUT}} = 0.4\text{ A}$	$V_{\text{SAT L}}$	–	0.25	0.40	V	$T_j = 25\text{ }^\circ\text{C}$
Sink (lower) $I_{\text{OUT}} = 0.8\text{ A}$	$V_{\text{SAT L}}$	–	0.45	0.75	V	$T_j = 25\text{ }^\circ\text{C}$

Total drop $I_{\text{OUT}} = 0.2\text{ A}$	V_{SAT}	–	1.0	1.4	V	$V_{\text{SAT}} = V_{\text{SAT U}} + V_{\text{SAT L}}$
Total drop $I_{\text{OUT}} = 0.4\text{ A}$	V_{SAT}	–	1.2	1.7	V	$V_{\text{SAT}} = V_{\text{SAT U}} + V_{\text{SAT L}}$
Total drop $I_{\text{OUT}} = 0.8\text{ A}$	V_{SAT}	–	1.6	2.5	V	$V_{\text{SAT}} = V_{\text{SAT U}} + V_{\text{SAT L}}$

Clamp Diodes

Forward voltage; upper	V_{FU}	–	1.0	1.5	V	$I_F = 0.4\text{ A}$
Upper leakage current	I_{LKU}	–		5	mA	$I_F = 0.4\text{ A}$
Forward voltage; lower	V_{FL}	–	0.9	1.4	V	$I_F = 0.4\text{ A}$

1.7 Electrical Characteristics (cont'd)
 $8\text{ V} < V_S < 18\text{ V}; I_{\text{OUT}1-2} = 0\text{ A}; -40\text{ }^\circ\text{C} < T_j < 150\text{ }^\circ\text{C}$ (unless otherwise specified)

Parameter	Symbol	Limit Values			Unit	Test Condition
		min.	typ.	max.		

Input-Interface
Input REF

Quiescent voltage	V_{REFq}	–	200	240	mV	$I_{\text{REF}} = 0\text{ }\mu\text{A}$
Input resistance	R_{REF}	4.5	6.0	7.5	k Ω	$0\text{ V} < V_{\text{REF}} < 0.5\text{ V}$

Input FB

Quiescent voltage	V_{FBq}	–	200	240	mV	$I_{\text{FB}} = 0\text{ }\mu\text{A}$
Input resistance	R_{FB}	4.5	6.0	7.5	k Ω	$0\text{ V} < V_{\text{FB}} < 0.5\text{ V}$

Input/Output HYST

Current Offset	$I_{\text{HYSTIO}250}$	– 2	0.35	3	μA	$I_{\text{REF}} = I_{\text{FB}} = 250\text{ }\mu\text{A}$ $V_{\text{HYST}} = V_S / 2$
	$I_{\text{HYSTIO}40}$	– 1.3	0	1.3	μA	$I_{\text{REF}} = I_{\text{FB}} = 40\text{ }\mu\text{A}$ $V_{\text{HYST}} = V_S / 2$
Current Amplification $A_{\text{HYST}} = I_{\text{HYST}} / (I_{\text{REF}} - I_{\text{FB}})$	A_{HYST}	0.8	0.95	1.1	–	$-20\text{ }\mu\text{A} < I_{\text{HYST}} < -10\text{ }\mu\text{A};$ $10\text{ }\mu\text{A} < I_{\text{HYST}} < 20\text{ }\mu\text{A};$ $I_{\text{REF}} = 250\text{ }\mu\text{A}$ $V_{\text{HYST}} = V_S / 2$
Current Gain $G_{\text{HYST}} = (I_{\text{HYST}} - I_{\text{HYSTIO}40}) / (I_{\text{REF}} - I_{\text{FB}})$	G_{HYST}	0.8	0.95	1.1	–	$I_{\text{HYST}} = \pm 2\text{ }\mu\text{A};$ $I_{\text{REF}} = 40\text{ }\mu\text{A};$ $V_{\text{HYST}} = V_S / 2$
Threshold voltage High	V_{HYH} / V_S	51	52	54	%	–
Deadband voltage High	V_{DBH} / V_S	50	50.4	51	%	–

1.7 Electrical Characteristics (cont'd)
 $8\text{ V} < V_S < 18\text{ V}; I_{\text{OUT}1-2} = 0\text{ A}; -40\text{ }^\circ\text{C} < T_j < 150\text{ }^\circ\text{C}$ (unless otherwise specified)

Parameter	Symbol	Limit Values			Unit	Test Condition
		min.	typ.	max.		
Deadband voltage Low	V_{DBL} / V_S	49	49.6	50	%	–
Threshold voltage Low	V_{HYL} / V_S	46	48	49	%	–
Hysteresis Window	V_{HYW} / V_S	3.0	4.0	5.0	%	$(V_{\text{HYH}} - V_{\text{HYL}}) / V_S$
Deadband Window	V_{DBW} / V_S	0.4	0.8	1.2	%	$(V_{\text{DBH}} - V_{\text{DBL}}) / V_S$

Input RANGE

Input current	I_{RANGE}	– 1	–	1	μA	$0\text{ V} < V_{\text{RANGE}} < V_S$
Switch-OFF voltage High	V_{OFFH}	-25	0	100	mV	refer to V_S
Switch-OFF voltage Low	V_{OFFL}	300	400	500	mV	refer to GND

Thermal Shutdown

Thermal shutdown junction temperature	T_{jSD}	150	175	200	$^\circ\text{C}$	–
Thermal switch-on junction temperature	T_{jSO}	120	–	170	$^\circ\text{C}$	–
Temperature hysteresis	ΔT	–	30		K	–

Note: The listed characteristics are ensured over the operating range of the integrated circuit. Typical characteristics specify mean values expected over the production spread. If not otherwise specified, typical characteristics apply at $T_A = 25\text{ }^\circ\text{C}$ and the given supply voltage.

2 Diagrams

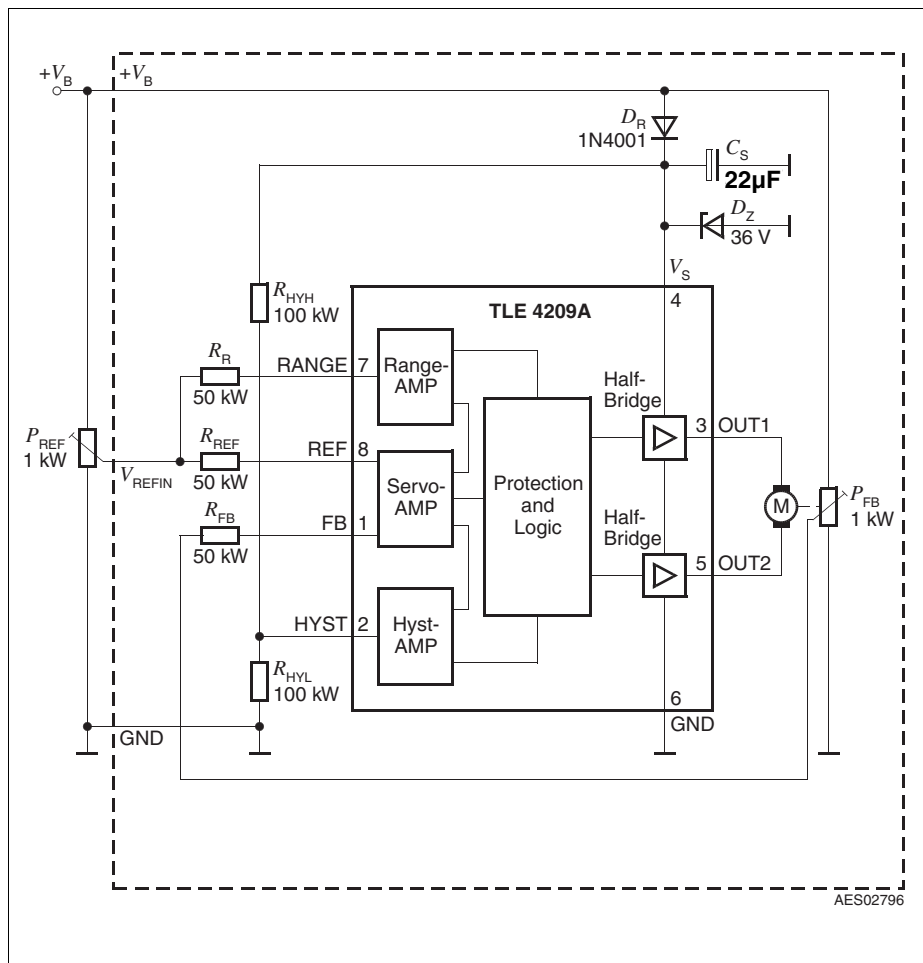

Figure 3 Application Circuit

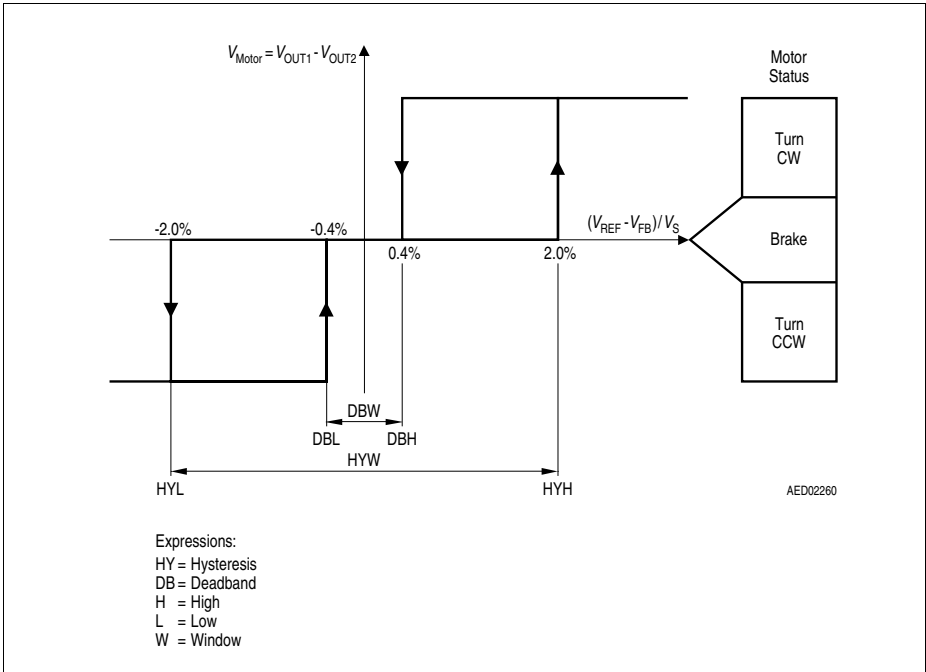

Figure 4 Hysteresis, Phaselag and Deadband-Definitions

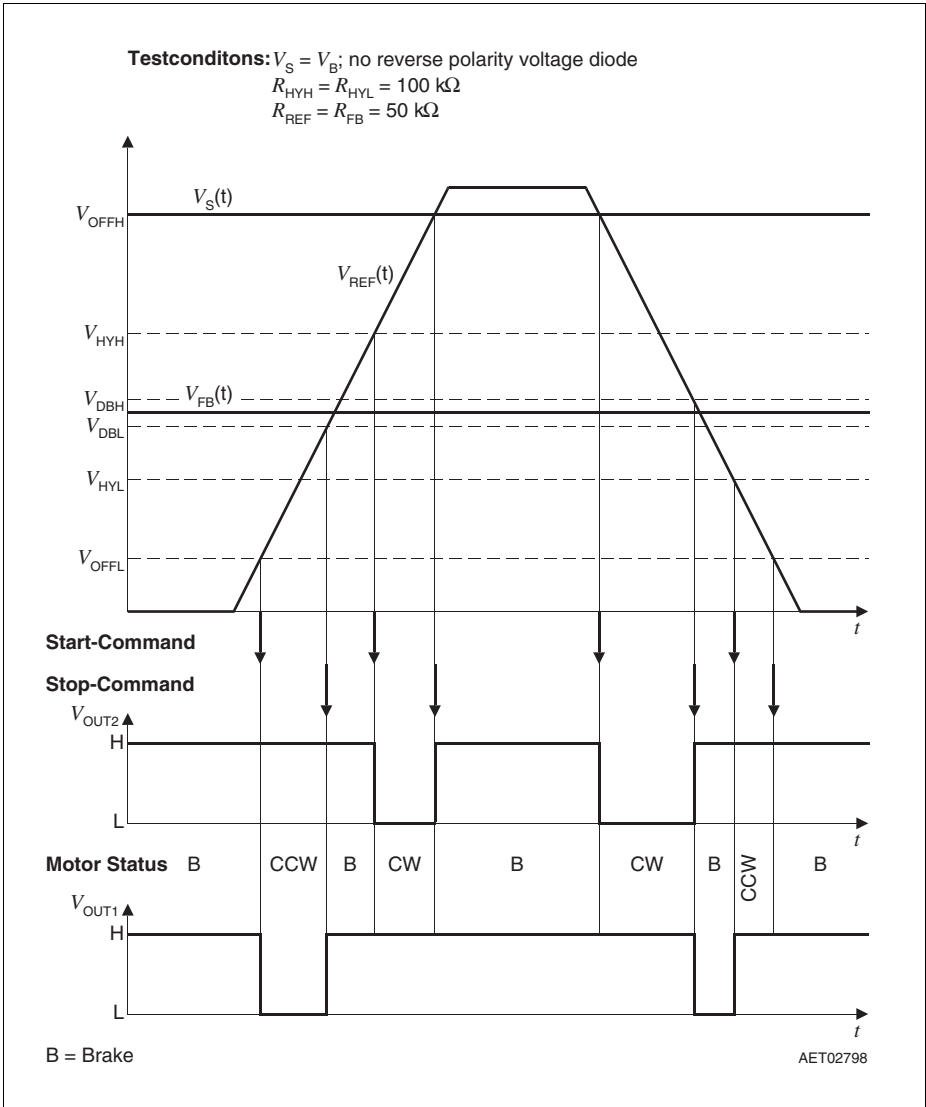

Figure 5 Timing and Phase-Lag

3 Package Outlines

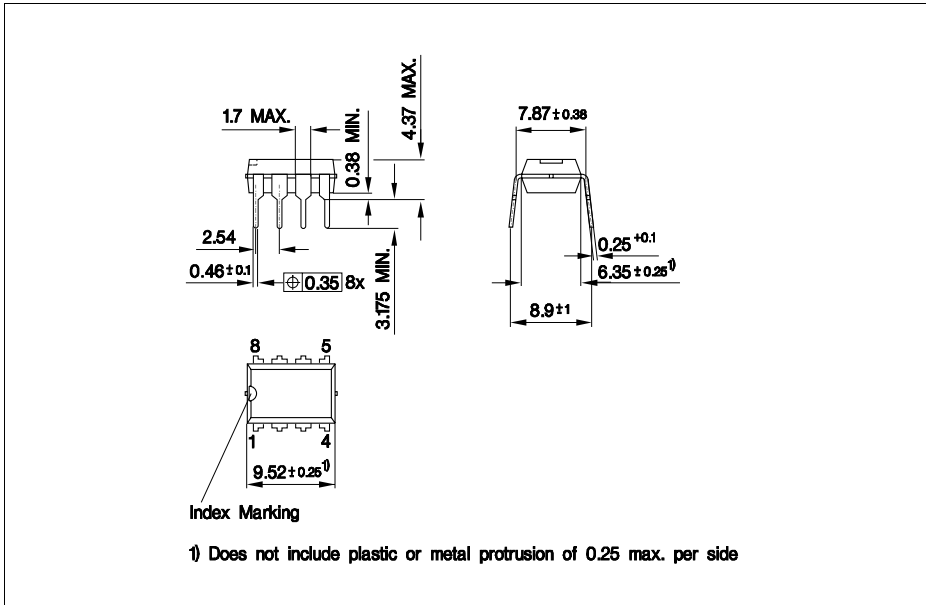

Figure 6 PG-DIP-8-4 (Plastic Dual In-line Package)

Green Product (RoHS compliant)

To meet the world-wide customer requirements for environmentally friendly products and to be compliant with government regulations the device is available as a green product. Green products are RoHS-Compliant (i.e Pb-free finish on leads and suitable for Pb-free soldering according to IPC/JEDEC J-STD-020).

Revision History

Revision	Date	Changes
Rev. 1.2	2016-07-25	<p>Page 8: Corrected specification of Switch-OFF voltage High (VOFFH): Previous specification min./typ./max.: 160 / 200 / 240 mV Corrected specification min./typ./max.: -25 / 0 / 100 mV</p> <p>Page 1: Editorial change: deleted "fully" (The term "fully protected" often leads to misunderstandings as it is unclear with respect to which parameters).</p>
Rev. 1.1	2007-07-23	<p>Page 1: added Green Product and AEC logo feature list:: deleted Pb-free Lead finish.... added Green Product and AEC Qualified</p>
		<p>Page 12: added Green Product description</p>
		<p>Page 14: updated disclaimer</p>
Rev. 1.0	2006-04-10	<p>Page1: Package name changed from P-DIP-8-4 to PG-DIP-8-4 (G stands for Green Package, Pb free lead finish) Changed package drawing) Expand feature List: Pb-free Lead finish (100% matte Sn)</p>
		<p>Page 12</p>
		<p>Page 13</p>
		<p>Page 14</p>
Prev. Rev.	2000-09-05	

Edition 2016-07-25

**Published by
Infineon Technologies AG
81726 Munich, Germany**

**© 2016 Infineon Technologies AG
All Rights Reserved.**

Legal Disclaimer

The information given in this document shall in no event be regarded as a guarantee of conditions or characteristics. With respect to any examples or hints given herein, any typical values stated herein and/or any information regarding the application of the device, Infineon Technologies hereby disclaims any and all warranties and liabilities of any kind, including without limitation, warranties of non-infringement of intellectual property rights of any third party.

Information

For further information on technology, delivery terms and conditions and prices, please contact the nearest Infineon Technologies Office (www.infineon.com).

Warnings

Due to technical requirements, components may contain dangerous substances. For information on the types in question, please contact the nearest Infineon Technologies Office.

Infineon Technologies components may be used in life-support devices or systems only with the express written approval of Infineon Technologies, if a failure of such components can reasonably be expected to cause the failure of that life-support device or system or to affect the safety or effectiveness of that device or system. Life support devices or systems are intended to be implanted in the human body or to support and/or maintain and sustain and/or protect human life. If they fail, it is reasonable to assume that the health of the user or other persons may be endangered.

X-ON Electronics

Largest Supplier of Electrical and Electronic Components

Click to view similar products for [Motor/Motion/Ignition Controllers & Drivers](#) category:

Click to view products by [Infineon](#) manufacturer:

Other Similar products are found below :

[FSB50550TB2](#) [FSBF15CH60BTH](#) [MSVCPM2-63-12](#) [MSVGW45-14-2](#) [MSVGW54-14-3](#) [MSVGW54-14-5](#) [NTE7043](#) [LA6565VR-TLM-E](#)
[LB11650-E](#) [LB1837M-TLM-E](#) [LB1845DAZ-XE](#) [LC898300XA-MH](#) [SS30-TE-L-E](#) [26700](#) [LV8281VR-TLM-H](#) [BA5839FP-E2](#) [IRAM236-1067A](#) [LA6584JA-AH](#) [LB11847L-E](#) [NCV70501DW002R2G](#) [AH293-PL-B](#) [STK672-630CN-E](#) [TND315S-TL-2H](#) [FNA23060](#) [FSB50250AB](#)
[FNA41060](#) [MSVB54](#) [MSVBTC50E](#) [MSVCPM3-54-12](#) [MSVCPM3-63-12](#) [MSVCPM4-63-12](#) [MSVTA120](#) [FSB50550AB](#)
[NCV70501DW002G](#) [LC898301XA-MH](#) [LV8413GP-TE-L-E](#) [MSVGW45-14-3](#) [MSVGW45-14-4](#) [MSVGW45-14-5](#) [MSVGW54-14-4](#)
[STK984-091A-E](#) [SLA7026M](#) [MP6519GQ-Z](#) [LB11651-E](#) [IRSM515-025DA4](#) [LV8127T-TLM-H](#) [NCP81382MNTXG](#) [TDA21801](#)
[LB11851FA-BH](#) [NCV70627DQ001R2G](#)