

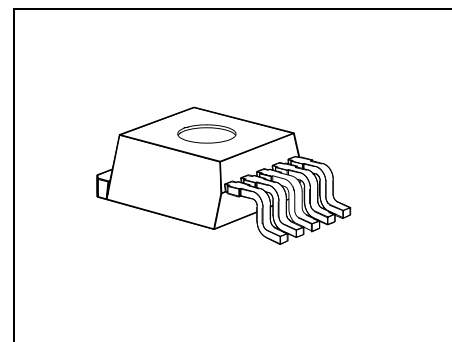

Features

- Output tracking tolerance $\leq \pm 0.2\%$
- 400 mA output current capability
- Enable Function
- Very low current consumption in OFF mode
- Wide operation range: up to 40 V
- Wide temperature range: $-40\text{ }^{\circ}\text{C} \leq T_j \leq 150\text{ }^{\circ}\text{C}$
- Output protected against short circuit
- Overtemperature protection
- Reverse polarity proof
- Green Product (RoHS compliant)
- AEC Qualified

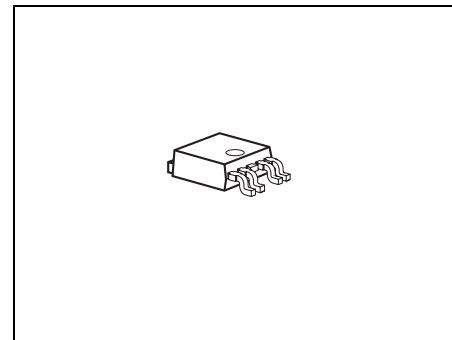

Functional Description

The **TLE 4251** is a monolithic integrated low drop voltage tracker in the very small SMD package PG-TO252-5-1. It is designed to supply e.g. sensors under the severe conditions of automotive applications. Therefore the device is equipped with additional protection functions against overload, short circuit and reverse polarity.

Supply voltages up to 40 V are tracked to a reference voltage given to the adjust input via an external resistor.

The output is able to drive loads up to 400 mA while it follows e.g. the 5 V output of a main voltage regulator within an accuracy of 0.5%. For loads up to 300 mA the tracking accuracy is 0.2%.

The **TLE 4251** can be switched in stand-by mode via the enable EN input which causes the current consumption to drop to very low values. This feature makes the IC suitable for low power battery applications.

Type	Package
TLE 4251 D	PG-TO252-5-11
TLE 4251 G	PG-TO263-5-1

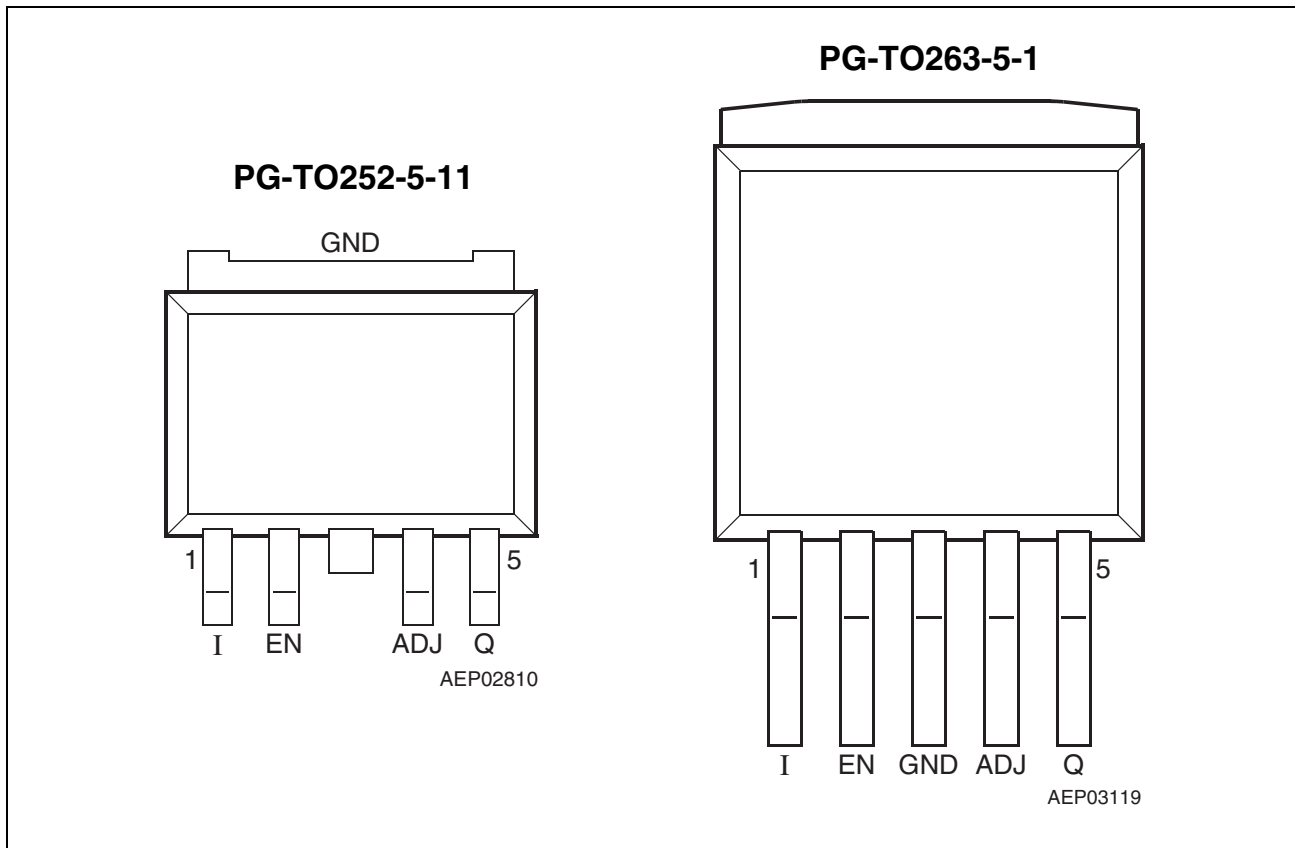

Figure 1 Pin Configuration (top view)

Table 1 Pin Definitions and Functions

Pin No.	Symbol	Function
1	I	Input voltage
2	EN	Enable; high-active input
3	GND	Ground
4	ADJ	Adjust; connect directly to the reference or with a voltage divider to the reference (for reference-proportional output voltages, $V_Q < V_{ref}$).....
5	Q	Output voltage; must be blocked by a capacitor $C_Q \geq 22 \mu F$, $ESR \leq 3 \Omega$ to GND

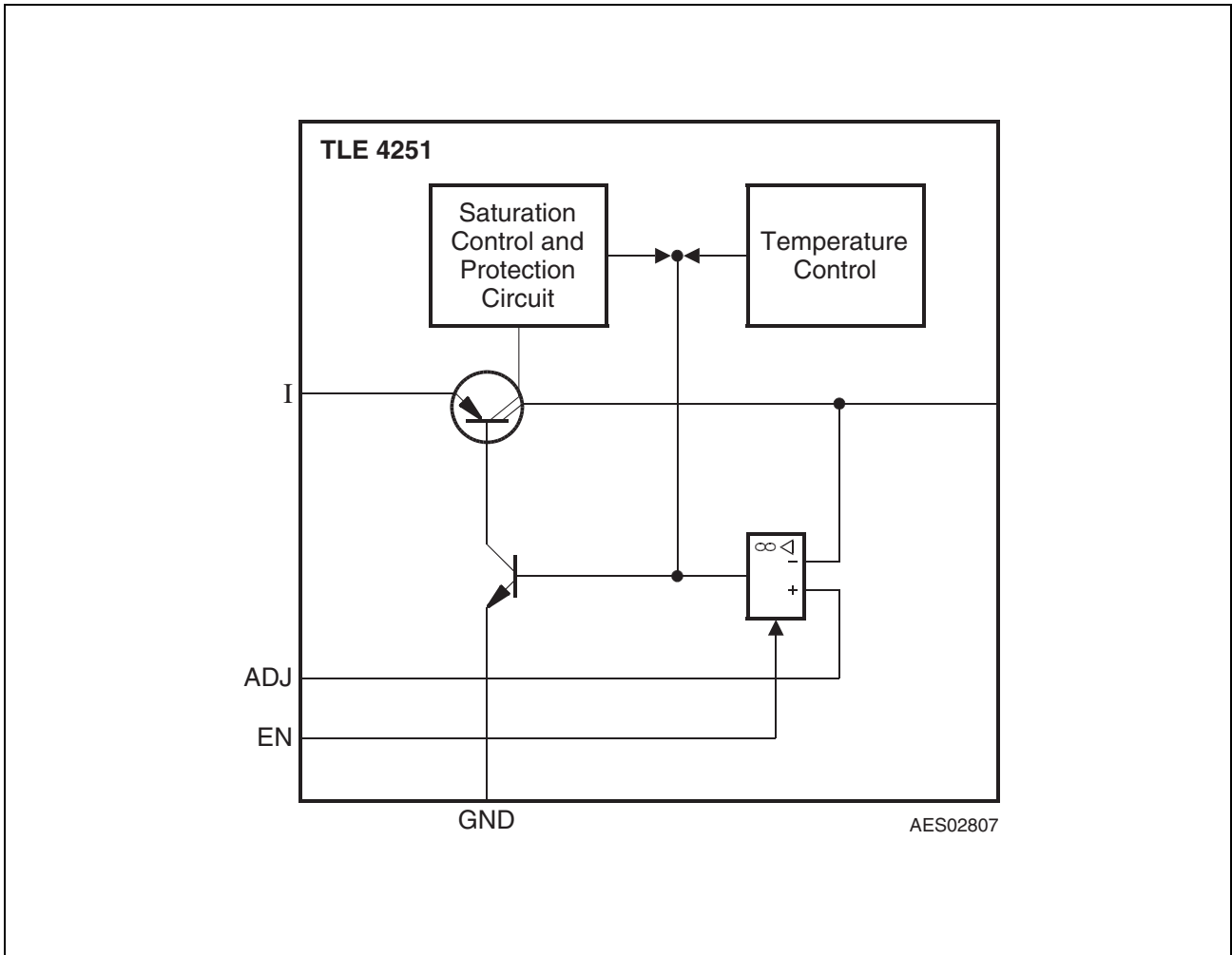

Figure 2 **Block Diagram**

Table 2 Absolute Maximum Ratings
 $-40\text{ °C} < T_j < 150\text{ °C}$

Parameter	Symbol	Limit Values		Unit	Remarks
		Min.	Max.		
Input					
Voltage	V_I	-42	45	V	–
Current	I_I	–	–	mA	internally limited
Output					
Voltage	V_Q	-2	45	V	–
Current	I_Q	–	–	mA	internally limited
Adjust					
Voltage	V_{ADJ}	-42	45	V	–
Current	I_{ADJ}	–	–	μA	internally limited
Enable					
Voltage	V_{EN}	-42	45	V	–
Current	I_{EN}	–	–	μA	internally limited
Temperatures					
Junction temperature	T_j	-40	150	$^{\circ}\text{C}$	–
Storage temperature	T_{stg}	-50	150	$^{\circ}\text{C}$	–
Thermal Resistances					
Junction case	R_{thjc}	–	4	K/W	TLE 4251 D
Junction ambient	R_{thja}	–	78	K/W	TLE 4251 D ¹⁾
Junction case	R_{thjc}	–	3	K/W	TLE 4251 G
Junction ambient	R_{thja}	–	52	K/W	TLE 4251 G ¹⁾

1) Worst case, regarding peak temperature; zero airflow; mounted on a PCB $80 \times 80 \times 1.5\text{ mm}^3$, heat sink area 300 mm^2 .

Note: Maximum ratings are absolute ratings; exceeding any one of these values may cause irreversible damage to the integrated circuit.

Table 3 Operating Range

Parameter	Symbol	Limit Values		Unit	Remarks
		Min.	Max.		
Input voltage	V_I	4 ¹⁾	40	V	–
Adjust input voltage	V_{ADJ}	2.5	40	V	–
Adjust input voltage	V_{ADJ}	0	2.5	V	$V_Q \leq V_{ADJ} + \Delta V_Q$
Enable input voltage	V_{EN}	0	40	V	–
Junction temperature	T_j	-40	150	°C	–

1) $V_I > V_{ADJ} + V_{DR}$

Table 4 Electrical Characteristics
 $V_1 = 13.5 \text{ V}; 2.5 \text{ V} \leq V_{\text{ADJ}} \leq V_1 - 0.5 \text{ V}; -40 \text{ }^\circ\text{C} < T_j < 150 \text{ }^\circ\text{C};$ unless otherwise specified

Parameter	Symbol	Limit Values			Unit	Test Condition
		Min.	Typ.	Max.		
Output						
Output voltage tracking accuracy $\Delta V_Q = V_{\text{ADJ}} - V_Q$	ΔV_Q	-10	–	10	mV	$V_1 < 13.5 \text{ V};$ $-40 \text{ }^\circ\text{C} < T_j < 125 \text{ }^\circ\text{C};$ $1 \text{ mA} < I_Q < 300 \text{ mA}$
Output voltage tracking accuracy	ΔV_Q	-10	–	10	mV	$6 \text{ V} < V_1 < 40 \text{ V};$ $5 \text{ mA} < I_Q < 200 \text{ mA}$
Output voltage tracking accuracy	ΔV_Q	-25	–	25	mV	$6 \text{ V} < V_1 < 28 \text{ V};$ $1 \text{ mA} < I_Q < 300 \text{ mA}$
Drop voltage	V_{dr}	–	280	520	mV	$I_Q = 300 \text{ mA};$ $V_{\text{ADJ}} > 4 \text{ V};$ Enable ON ¹⁾
Output current	I_Q	400	450	800	mA	$T_j \leq 125 \text{ }^\circ\text{C}^{1)}$
Output capacitor	C_Q	22	–	–	μF	$\text{ESR} \leq 3 \text{ } \Omega$ at 10 kHz
Current consumption $I_q = I_1 - I_Q$	I_q	–	10	20	mA	$I_Q = 300 \text{ mA}$
Current consumption $I_q = I_1 - I_Q$	I_q	–	230	300	μA	$I_Q < 1 \text{ mA}; T_j < 85 \text{ }^\circ\text{C};$ V_{EN} in ON state
Quiescent current (stand-by) $I_q = I_1 - I_Q$	I_q	–	0	2	μA	$V_{\text{EN}} = 0 \text{ V}; T_j < 85 \text{ }^\circ\text{C}$
Regulator Performance						
Load regulation	ΔV_Q	-35	± 5	35	mV	$5 \text{ mA} < I_Q < 300 \text{ mA};$ $V_1 = 6 \text{ V}; V_{\text{ADJ}} = 5 \text{ V}$
Line regulation	ΔV_Q	-25	± 10	25	mV	$12 \text{ V} < V_1 < 32 \text{ V};$ $I_Q = 5 \text{ mA}$
Power Supply Ripple Rejection	$PSRR$	60	–	–	dB	$f_r = 100 \text{ Hz};$ $V_r = 0.5 \text{ Vpp};$ $V_{\text{ADJ}} = 5 \text{ V};$ $C_Q = 22 \text{ } \mu\text{F}$ Tantalum
Adjust Input						
Input biasing current	I_{ADJ}	–	0.1	0.5	μA	$V_{\text{ADJ}} = 5 \text{ V}$

Table 4 Electrical Characteristics (cont'd)

$V_I = 13.5\text{ V}$; $2.5\text{ V} \leq V_{ADJ} \leq V_I - 0.5\text{ V}$; $-40\text{ }^\circ\text{C} < T_j < 150\text{ }^\circ\text{C}$; unless otherwise specified

Parameter	Symbol	Limit Values			Unit	Test Condition
		Min.	Typ.	Max.		
Enable						
Enable on voltage range	$V_{EN\ ON}$	2	–	–	V	$V_Q\ ON$
Enable off voltage range	$V_{EN\ OFF}$	–	–	0.5	V	$V_Q \leq 0.1\text{ V}$
Input current	I_{EN}	5	40	70	μA	$V_{EN} = 5\text{ V}$

1) Measured when the output voltage V_Q has dropped 100 mV from the nominal value.

Application Information

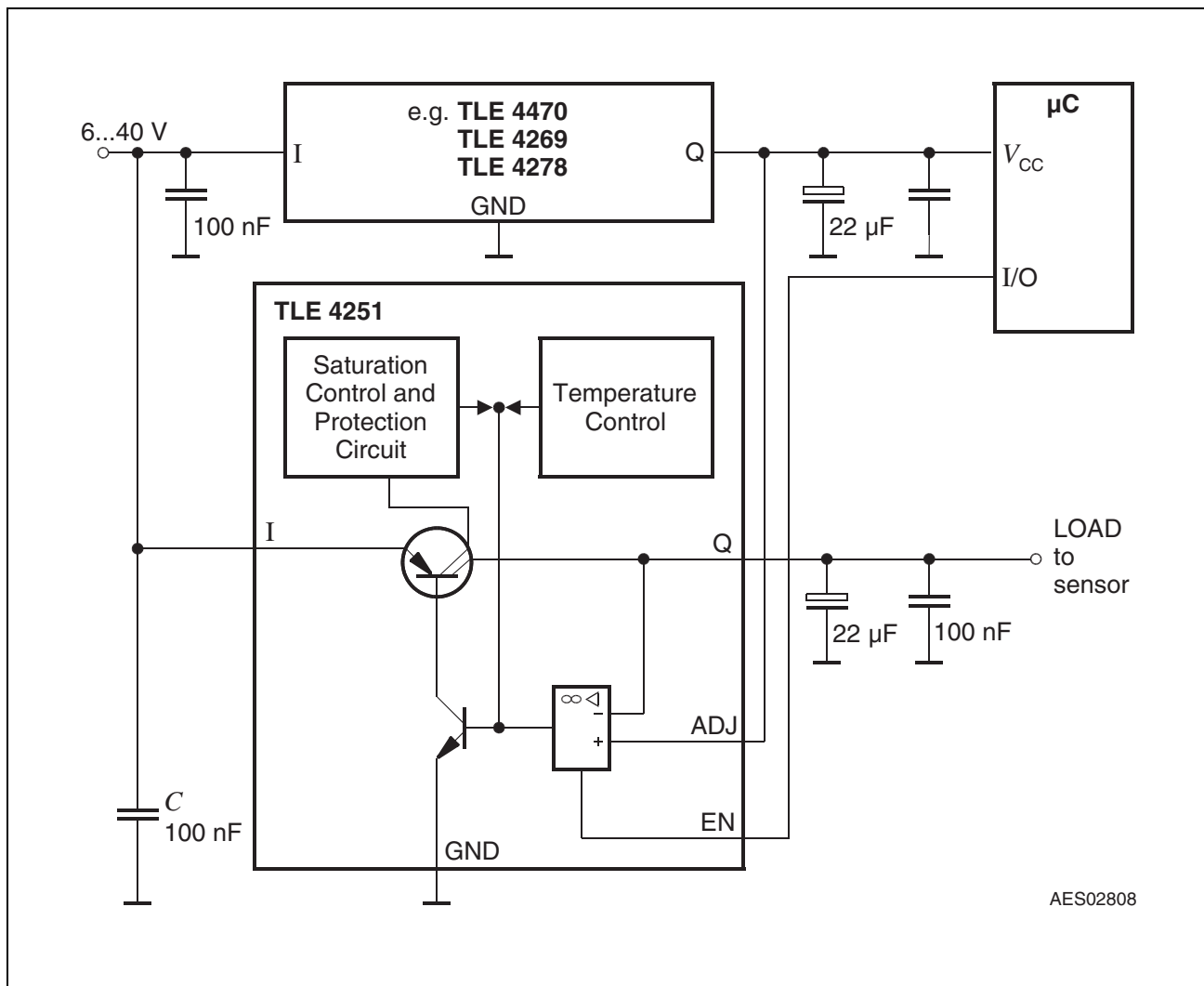
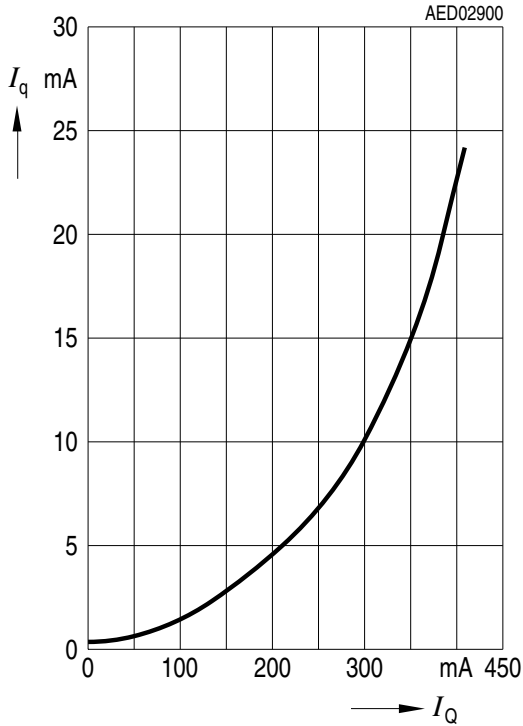
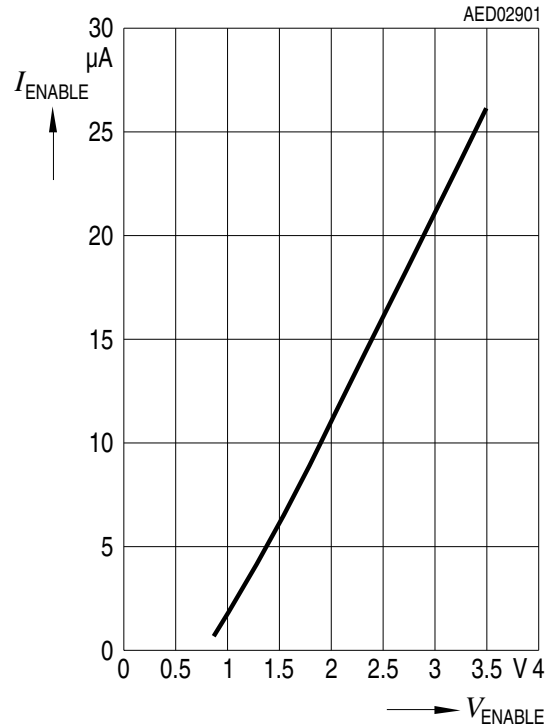

Figure 3 Application Circuit

Quiescent Current I_q versus Output Current I_Q



Enable Current I_{EN} versus Enable Voltage V_{EN}



Tracking Accuracy ΔV_Q versus Temperature T_j , $V_{ADJ} = 5 V$

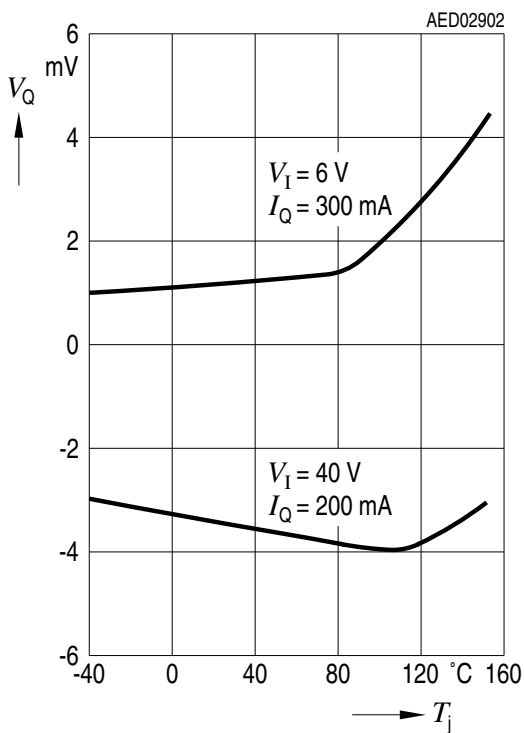

Current Consumption I_q versus Input Voltage V_I , $V_{ADJ} = 5 V$

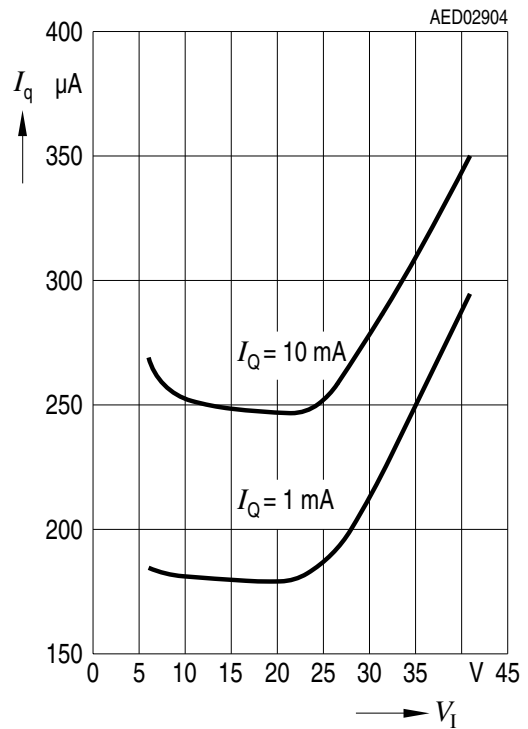

Tracking Accuracy ΔV_Q versus Output Current I_Q

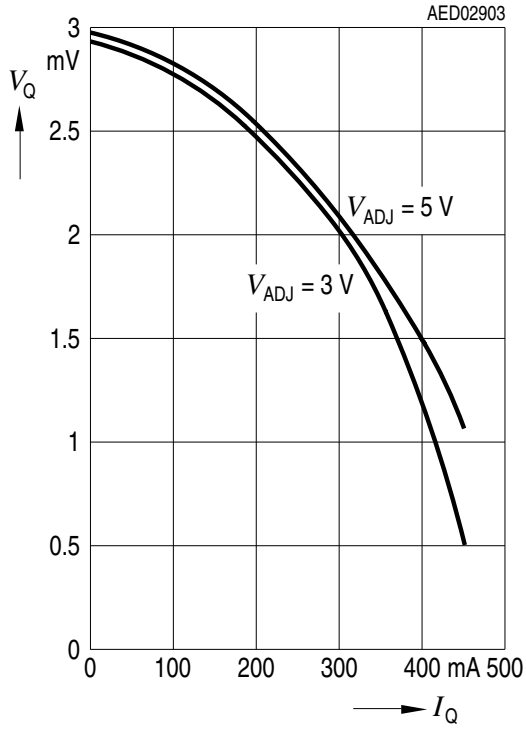

Package Outlines

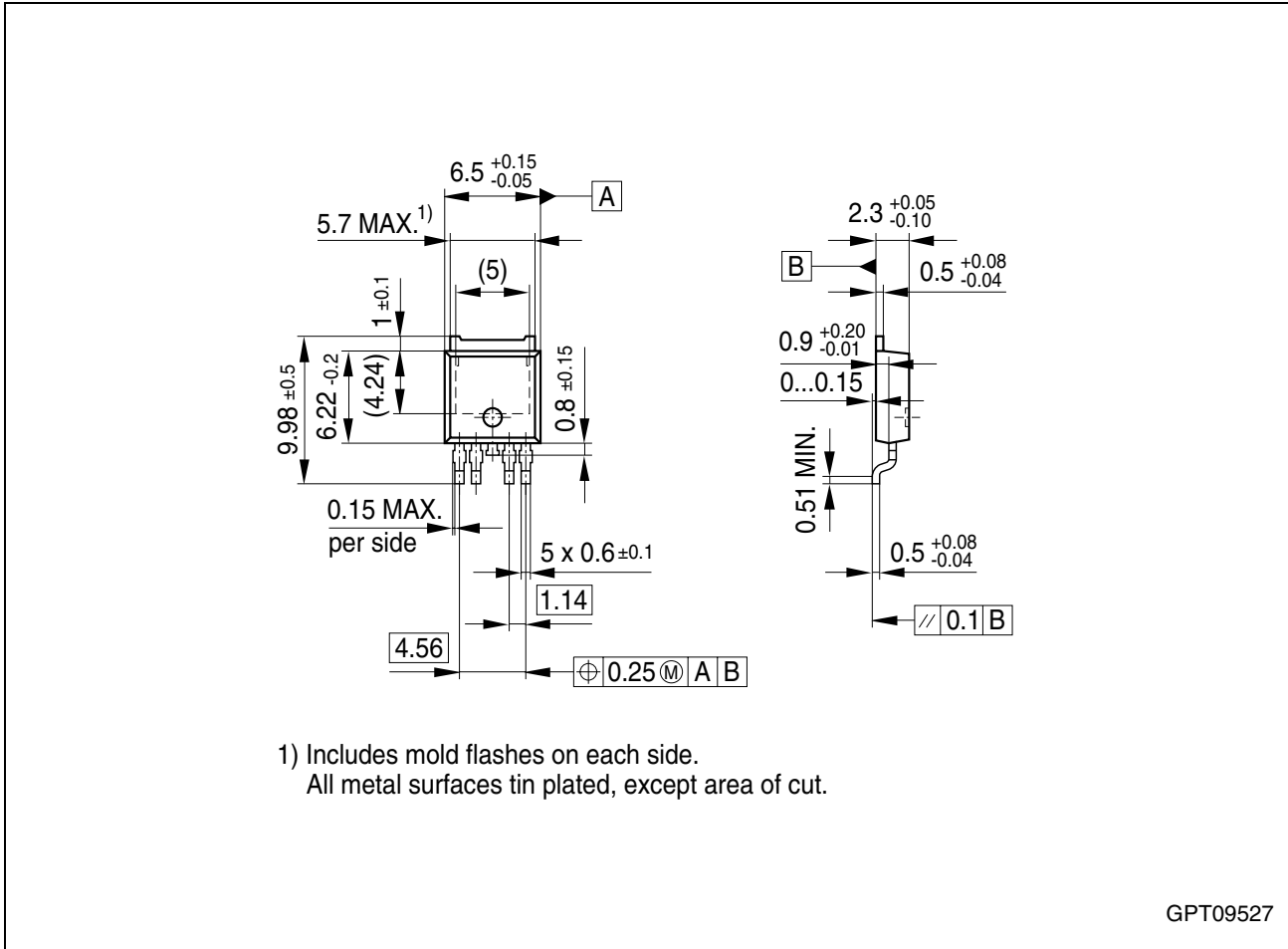

Figure 4 PG-T0252-5-11 (Plastic Transistor Single Outline)

Green Product (RoHS compliant)

To meet the world-wide customer requirements for environmentally friendly products and to be compliant with government regulations the device is available as a green product. Green products are RoHS-Compliant (i.e Pb-free finish on leads and suitable for Pb-free soldering according to IPC/JEDEC J-STD-020).

You can find all of our packages, sorts of packing and others in our Infineon Internet Page "Products": <http://www.infineon.com/products>.

SMD = Surface Mounted Device

Dimensions in mm

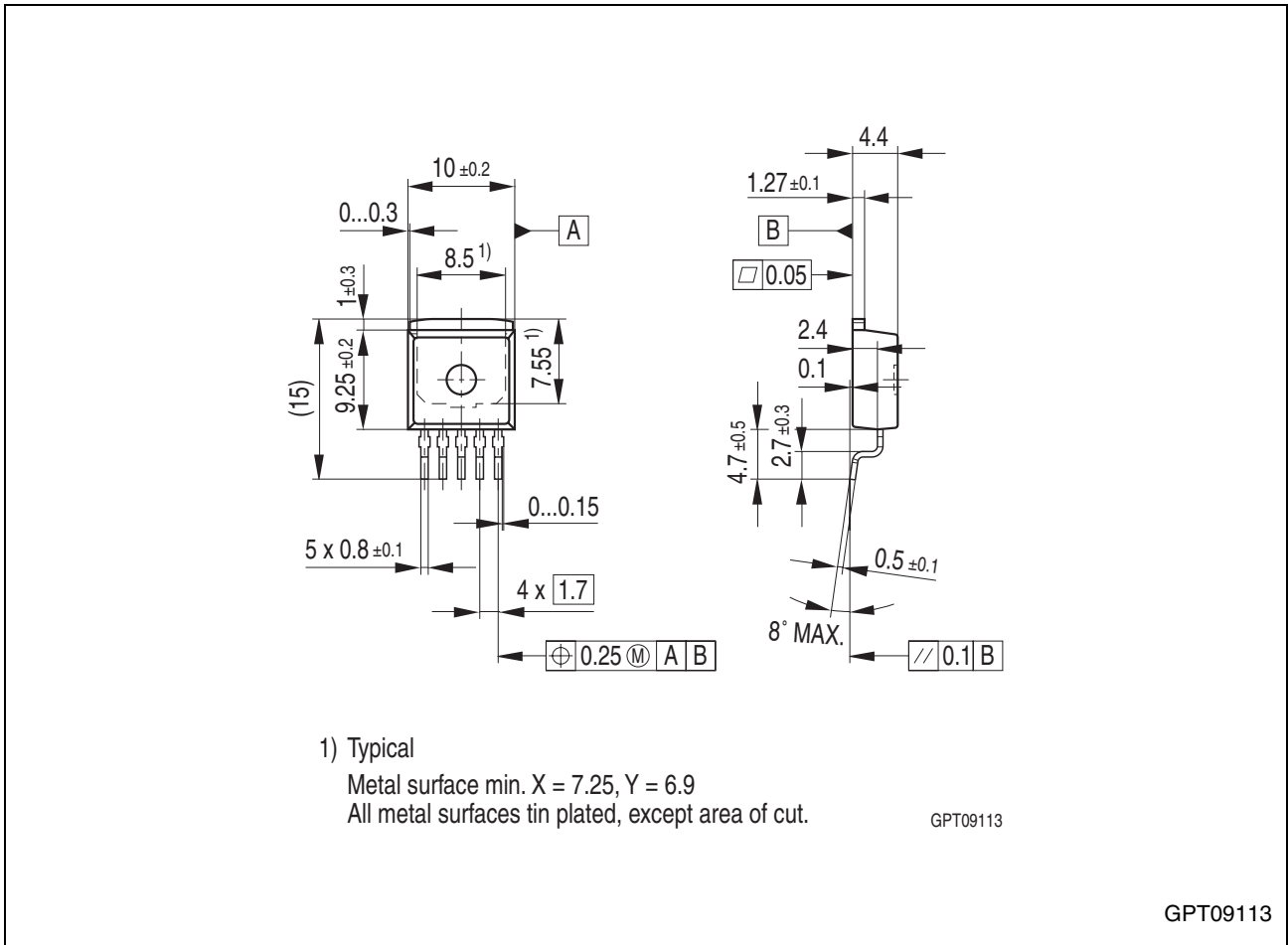

Figure 5 PG-TO263-5-1 (Plastic Transistor Single Outline)

Green Product (RoHS compliant)

To meet the world-wide customer requirements for environmentally friendly products and to be compliant with government regulations the device is available as a green product. Green products are RoHS-Compliant (i.e Pb-free finish on leads and suitable for Pb-free soldering according to IPC/JEDEC J-STD-020).

You can find all of our packages, sorts of packing and others in our Infineon Internet Page "Products": <http://www.infineon.com/products>.

SMD = Surface Mounted Device

Dimensions in mm

Revision History

Version	Date	Changes
Rev. 2.9	2007-03-20	Initial version of RoHS-compliant derivate of TLE 4251 Page 1 : AEC certified statement added Page 1 and Page 10 : RoHS compliance statement and Green product feature added Page 1 and Page 10 : Package changed to RoHS compliant version Legal Disclaimer updated

Edition 2007-03-20

**Published by
Infineon Technologies AG
81726 Munich, Germany**

**© 2007 Infineon Technologies AG
All Rights Reserved.**

Legal Disclaimer

The information given in this document shall in no event be regarded as a guarantee of conditions or characteristics. With respect to any examples or hints given herein, any typical values stated herein and/or any information regarding the application of the device, Infineon Technologies hereby disclaims any and all warranties and liabilities of any kind, including without limitation, warranties of non-infringement of intellectual property rights of any third party.

Information

For further information on technology, delivery terms and conditions and prices, please contact the nearest Infineon Technologies Office (www.infineon.com).

Warnings

Due to technical requirements, components may contain dangerous substances. For information on the types in question, please contact the nearest Infineon Technologies Office.

Infineon Technologies components may be used in life-support devices or systems only with the express written approval of Infineon Technologies, if a failure of such components can reasonably be expected to cause the failure of that life-support device or system or to affect the safety or effectiveness of that device or system. Life support devices or systems are intended to be implanted in the human body or to support and/or maintain and sustain and/or protect human life. If they fail, it is reasonable to assume that the health of the user or other persons may be endangered.

X-ON Electronics

Largest Supplier of Electrical and Electronic Components

Click to view similar products for [LDO Voltage Regulators](#) category:

Click to view products by [Infineon](#) manufacturer:

Other Similar products are found below :

[AP7363-SP-13](#) [NCV8664CST33T3G](#) [L79M05TL-E](#) [AP7362-HA-7](#) [PT7M8202B12TA5EX](#) [TCR3DF185,LM\(CT](#) [TLF4949EJ](#)
[NCP4687DH15T1G](#) [NCV8703MX30TCG](#) [LP2951CN](#) [NCV4269CPD50R2G](#) [AP7315-25W5-7](#) [NCV47411PAAJR2G](#) [AP2111H-1.2TRG1](#)
[ZLDO1117QK50TC](#) [AZ1117ID-ADJTRG1](#) [NCV4263-2CPD50R2G](#) [NCP114BMX075TCG](#) [MC33269T-3.5G](#) [TLE4471GXT](#) [AP7315-33SA-](#)
[7](#) [NCV4266-2CST33T3G](#) [NCP715SQ15T2G](#) [NCV8623MN-50R2G](#) [NCV563SQ18T1G](#) [NCV8664CDT33RKG](#) [NCV4299CD250R2G](#)
[NCP715MX30TBG](#) [NCV8702MX25TCG](#) [TLE7270-2E](#) [NCV562SQ25T1G](#) [AP2213D-3.3TRG1](#) [AP2202K-2.6TRE1](#)
[NCV8170BMX300TCG](#) [NCV8152MX300180TCG](#) [NCP700CMT45TBG](#) [AP7315-33W5-7](#) [NCP154MX180300TAG](#) [AP2113AMTR-G1](#)
[NJV4104U2-33A-TE1](#) [MP2013AGG-5-P](#) [NCV8775CDT50RKG](#) [NJM2878F3-45-TE1](#) [S-19214B00A-V5T2U7](#) [S-19214B50A-V5T2U7](#) [S-](#)
[19213B50A-V5T2U7](#) [S-19214BC0A-E8T1U7*1](#) [S-19213B00A-V5T2U7](#) [S-19213B33A-V5T2U7](#) [S-19213BC0A-V5T2U7](#)