

TLE42764

Low Dropout Linear Voltage Regulator

TLE42764GV50
TLE42764DV50
TLE42764EV50
TLE42764GV
TLE42764DV

Data Sheet

Rev. 1.3, 2013-07-30

Automotive Power



1 Overview

Features

- Very Low Current Consumption
- Adjustable and 5 V Fixed Output Voltage $\pm 2\%$
- Output Current up to 400 mA
- Enable Input
- Very Low Dropout Voltage
- Output Current Limitation
- Overtemperature Shutdown
- Reverse Polarity Protection
- Wide Temperature Range From $-40\text{ }^{\circ}\text{C}$ up to $150\text{ }^{\circ}\text{C}$
- Green Product (RoHS compliant)
- AEC Qualified

Description

The TLE42764 is a monolithic integrated low dropout voltage regulator for load currents up to 400 mA. An input voltage up to 40 V is regulated to an adjustable or 5 V fixed voltage with a precision of $\pm 2\%$. The device is designed for the harsh environment of automotive applications. Therefore it is protected against overload, short circuit and overtemperature conditions by the implemented output current limitation and the overtemperature shutdown circuit. The TLE42764 can be also used in all other applications requiring a stabilized voltage between 2.5 V and 20 V.

Due to its very low quiescent current the TLE42764 is dedicated for use in applications permanently connected to V_{BAT} . In addition the device can be switched off via the Enable input reducing the current consumption to less than $10\text{ }\mu\text{A}$.

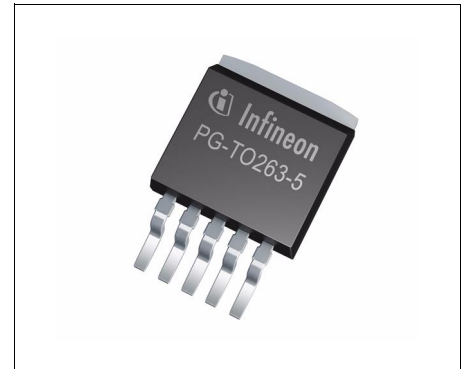

PG-TO263-5

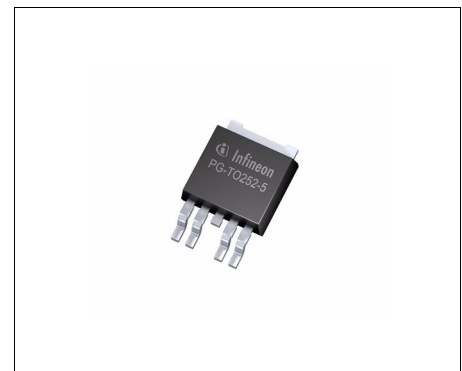

PG-TO252-5

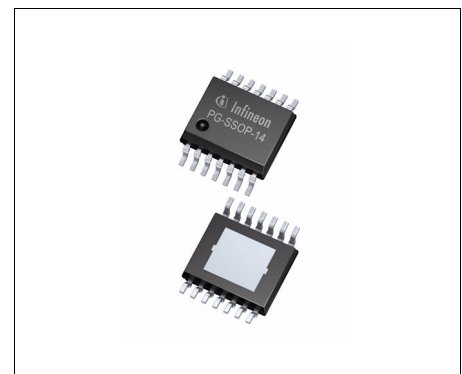

PG-SSOP-14 exposed pad

Type	Package	Marking
TLE42764GV50	PG-TO263-5	42764V5
TLE42764DV50	PG-TO252-5	42764V5
TLE42764GV	PG-TO263-5	42764V
TLE42764DV	PG-TO252-5	42764V
TLE42764EV50	PG-SSOP-14 exposed pad	42764V5

2 Block Diagram

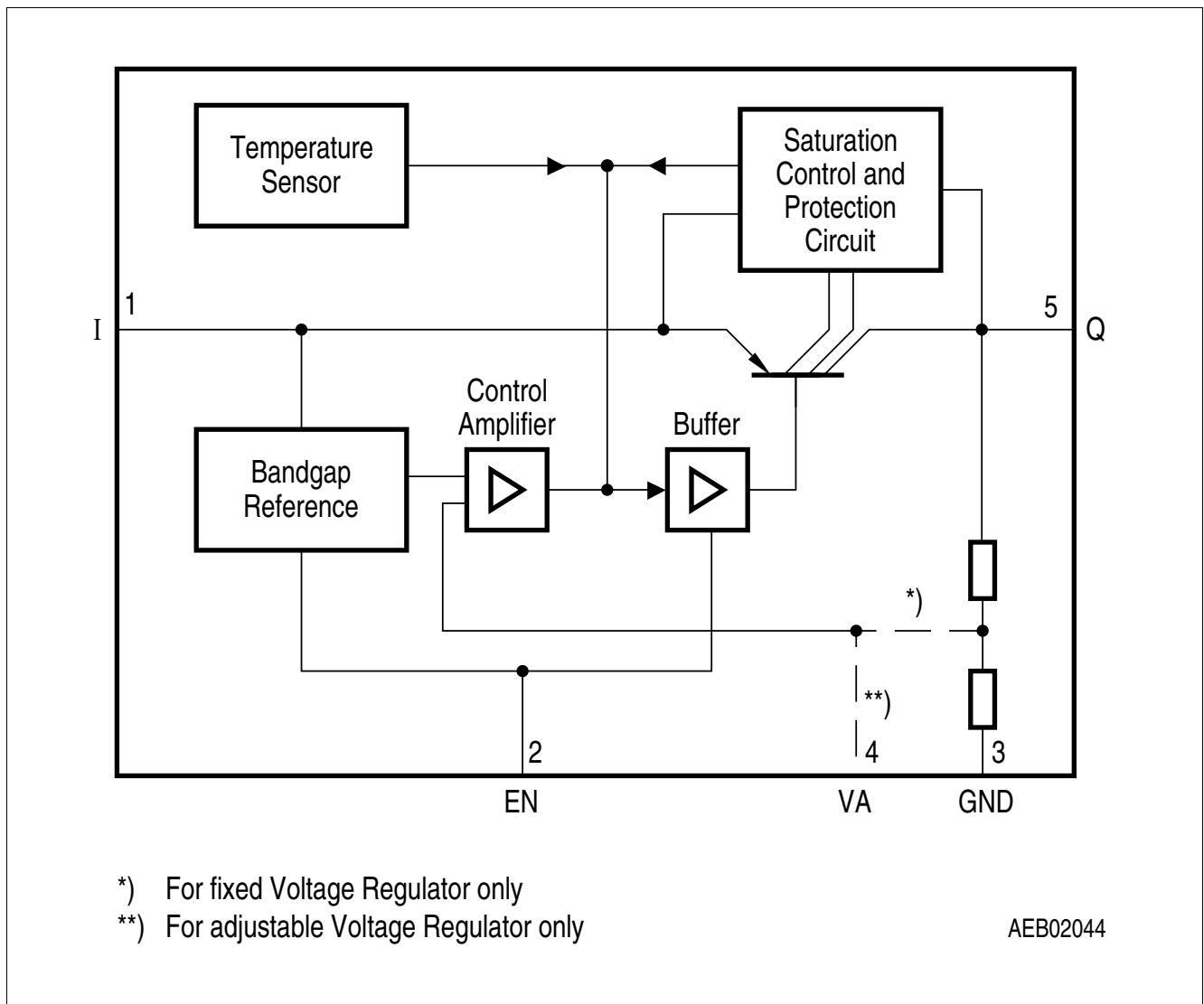

Figure 1 Block Diagram

3 Pin Configuration

3.1 Pin Assignment PG-TO263-5, PG-TO252-5

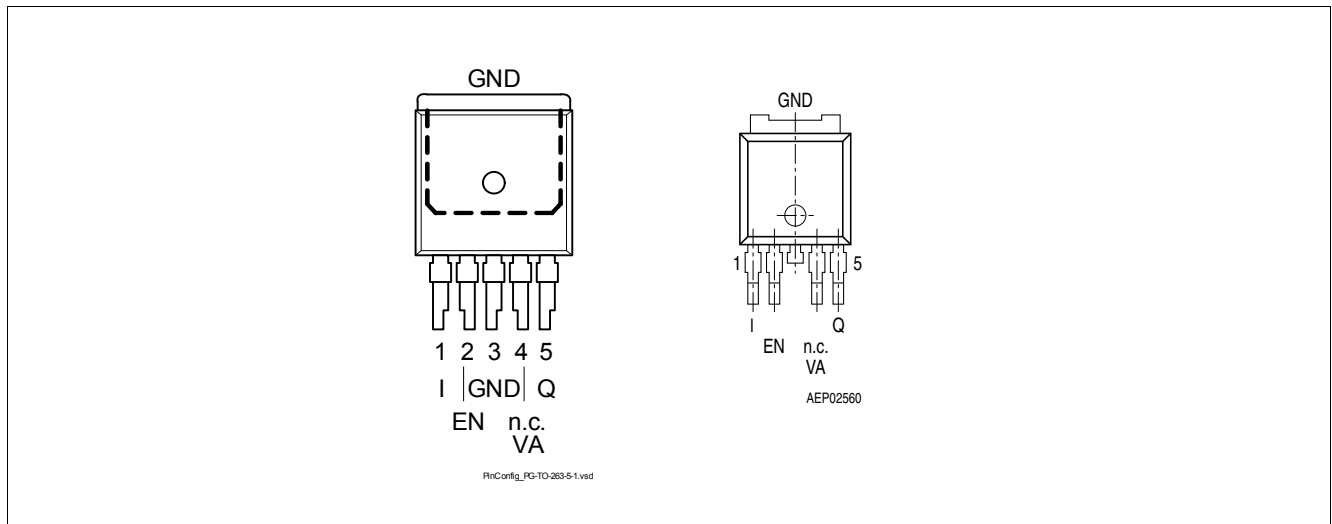

Figure 2 Pin Configuration (top view)

3.2 Pin Definitions and Functions PG-TO263-5, PG-TO252-5

Pin No.	Symbol	Function
1	I	Input block to ground directly at the IC with a ceramic capacitor
2	EN	Enable Input high level input signal enables the IC; low level input signal disables the IC; integrated pull-down resistor
3	GND	Ground internally connected to heat slug
4	n.c. VA	not connected for TLE42764GV50, TLE42764DV50 can be open or connected to GND Voltage Adjust Input for TLE42764GV, TLE42764DV connect external voltage divider to configure the output voltage
5	Q	Output block to ground with a capacitor close to the IC terminals, respecting the values given for its capacitance and ESR in “Functional Range” on Page 7
Heat Slug	–	Heat Slug internally connected to GND; connect to GND and heatsink area

3.3 Pin Assignment PG-SSOP-14 exposed pad

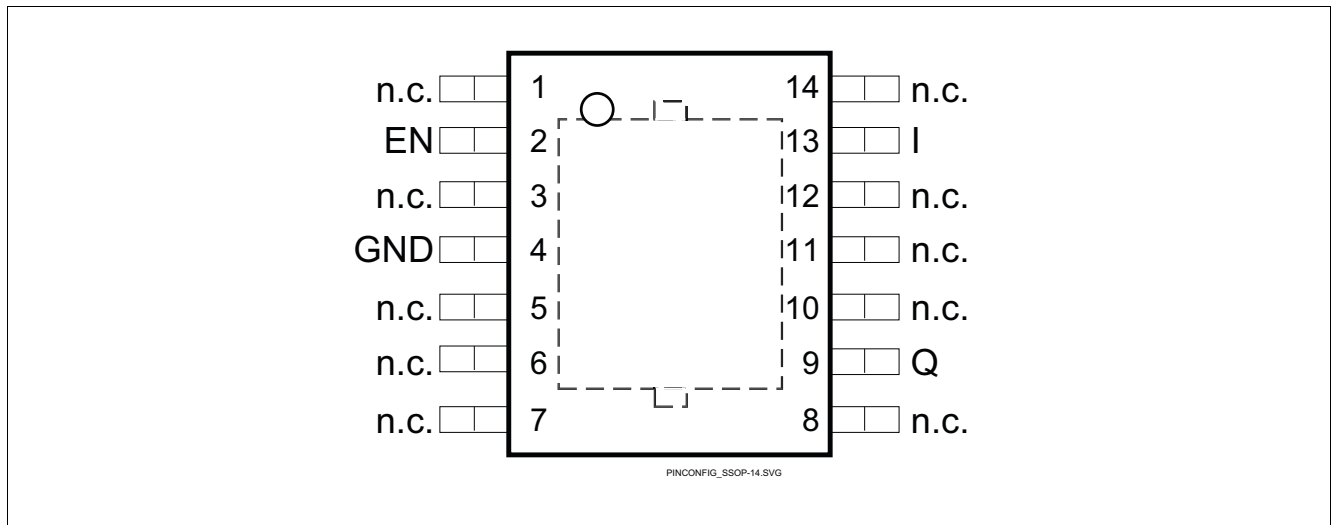

Figure 3 Pin Configuration (top view)

3.4 Pin Definitions and Functions PG-SSOP-14 exposed pad

Pin No.	Symbol	Function
1, 3, 5-7	n.c.	non connected can be open or connected to GND
2	EN	Enable Input high level input signal enables the IC; low level input signal disables the IC; integrated pull-down resistor
4	GND	Ground
8, 10-12, 14	n.c.	non connected can be open or connected to GND
9	Q	Output block to ground with a capacitor close to the IC terminals, respecting the values given for its capacitance and ESR in “Functional Range” on Page 7
13	I	Input block to ground directly at the IC with a ceramic capacitor
Exposed Pad	–	Exposed Pad connect to GND and heatsink area

4 General Product Characteristics

4.1 Absolute Maximum Ratings

Table 1 Absolute Maximum Ratings¹⁾

$T_j = -40\text{ °C}$ to 150 °C ; all voltages with respect to ground, (unless otherwise specified)

Pos.	Parameter	Symbol	Limit Values		Unit	Test Condition
			Min.	Max.		
Input I, Enable EN						
4.1.1	Voltage	V_I	-42	45	V	–
Voltage Adjust Input VA						
4.1.2	Voltage	V_{VA}	-0.3	10	V	–
Output Q						
4.1.3	Voltage	V_Q	-1	40	V	–
Temperature						
4.1.4	Junction temperature	T_j	-40	150	°C	–
4.1.5	Storage temperature	T_{stg}	-50	150	°C	–
ESD Susceptibility						
4.1.6	ESD Absorption	$V_{ESD,HBM}$	-3	3	kV	Human Body Model (HBM) ²⁾
4.1.7		$V_{ESD,CDM}$	-1000	1000	V	Charge Device Model (CDM) ³⁾ at all pins

1) not subject to production test, specified by design

2) ESD susceptibility Human Body Model “HBM” according to AEC-Q100-002 - JESD22-A114

3) ESD susceptibility Charged Device Model “CDM” according to ESDA STM5.3.1

Note: Stresses above the ones listed here may cause permanent damage to the device. Exposure to absolute maximum rating conditions for extended periods may affect device reliability.

Note: Integrated protection functions are designed to prevent IC destruction under fault conditions described in the data sheet. Fault conditions are considered as “outside” normal operating range. Protection functions are not designed for continuous repetitive operation.

4.2 Functional Range

Table 2 Functional Range

Pos.	Parameter	Symbol	Limit Values		Unit	Remarks
			Min.	Max.		
4.2.1	Input voltage	V_I	5.5	40	V	TLE42764GV50, TLE42764DV50, TLE42764EV50
4.2.2	Input voltage	V_I	$V_Q + 0.5$	40	V	TLE42764GV, TLE42764DV; $V_Q > 4\text{ V}$
4.2.3	Input voltage	V_I	4.5	40	V	TLE42764GV, TLE42764DV; $V_Q < 4\text{ V}$
4.2.4	Output Capacitor's	C_Q	22	–	μF	¹⁾
4.2.5	Requirements for Stability	$ESR(C_Q)$	–	3	Ω	²⁾
4.2.6	Junction temperature	T_j	-40	150	$^{\circ}\text{C}$	–

1) The minimum output capacitance requirement is applicable for a worst case capacitance tolerance of 30%

2) Relevant ESR value at $f = 10\text{ kHz}$

Note: Within the functional or operating range, the IC operates as described in the circuit description. The electrical characteristics are specified within the conditions given in the Electrical Characteristics table.

4.3 Thermal Resistance

Note: This thermal data was generated in accordance with JEDEC JESD51 standards. For more information, go to www.jedec.org.

Table 3 Thermal Resistance

Pos.	Parameter	Symbol	Limit Values			Unit	Conditions
			Min.	Typ.	Max.		
TLE42764GV, TLE42764GV50 (PG-TO263-5)							
4.3.1	Junction to Case ¹⁾	R_{thJC}	–	3.6	–	K/W	measured to heat slug
4.3.2	Junction to Ambient ¹⁾	R_{thJA}	–	22	–	K/W	²⁾
4.3.3			–	74	–	K/W	footprint only ³⁾
4.3.4			–	42	–	K/W	300 mm ² heatsink area ³⁾
4.3.5			–	34	–	K/W	600 mm ² heatsink area ³⁾
TLE42764DV, TLE42764DV50 (PG-TO252-5)							
4.3.6	Junction to Case ¹⁾	R_{thJC}	–	3.6	–	K/W	measured to heat slug
4.3.7	Junction to Ambient ¹⁾	R_{thJA}	–	27	–	K/W	²⁾
4.3.8			–	115	–	K/W	footprint only ³⁾
4.3.9			–	52	–	K/W	300 mm ² heatsink area ³⁾
4.3.10			–	40	–	K/W	600 mm ² heatsink area ³⁾
TLE42764EV50 (PG-SSOP-14 exposed pad)							
4.3.11	Junction to Case ¹⁾	R_{thJC}	–	7	–	K/W	–
4.3.12	Junction to Ambient ¹⁾	R_{thJA}	–	41	–	K/W	²⁾
4.3.13			–	130	–	K/W	footprint only ³⁾
4.3.14			–	60	–	K/W	300 mm ² heatsink area on PCB ³⁾
4.3.15			–	50	–	K/W	600 mm ² heatsink area on PCB ³⁾

1) Not subject to production test, specified by design.

2) Specified R_{thJA} value is according to Jedec JESD51-2,-5,-7 at natural convection on FR4 2s2p board; The Product (Chip+Package) was simulated on a 76.2 x 114.3 x 1.5 mm³ board with 2 inner copper layers (2 x 70µm Cu, 2 x 35µm Cu). Where applicable a thermal via array under the exposed pad contacted the first inner copper layer.

3) Specified R_{thJA} value is according to Jedec JESD 51-3 at natural convection on FR4 1s0p board; The Product (Chip+Package) was simulated on a 76.2 x 114.3 x 1.5 mm³ board with 1 copper layer (1 x 70µm Cu).

5 Electrical Characteristics

5.1 Electrical Characteristics Voltage Regulator

Table 4 Electrical Characteristics

 $V_I = 13.5 \text{ V}$; $T_j = -40 \text{ }^\circ\text{C}$ to $150 \text{ }^\circ\text{C}$; all voltages with respect to ground (unless otherwise specified)

Pos.	Parameter	Symbol	Limit Values			Unit	Measuring Condition
			Min.	Typ.	Max.		
Output Q							
5.1.1	Output Voltage	V_Q	4.9	5.0	5.1	V	TLE42764GV50, TLE42764DV50, TLE42764EV50 $5 \text{ mA} < I_Q < 400 \text{ mA}$ $6 \text{ V} < V_I < 28 \text{ V}$
5.1.2	Output Voltage	V_Q	4.9	5.0	5.1	V	TLE42764GV50, TLE42764DV50, TLE42764EV50 $5 \text{ mA} < I_Q < 200 \text{ mA}$ $6 \text{ V} < V_I < 40 \text{ V}$
5.1.3	Output Voltage ¹⁾	ΔV_Q	-2	–	2	%	TLE42764GV, TLE42764DV; $R_2 < 50 \text{ k}\Omega$; $V_Q + 1 \text{ V} < V_I < 28 \text{ V}$; $V_I > 4.5 \text{ V}$; $5 \text{ mA} \leq I_Q \leq 400 \text{ mA}$
		ΔV_Q	-2	–	2	%	TLE42764GV, TLE42764DV; $R_2 < 50 \text{ k}\Omega$; $V_Q + 1 \text{ V} < V_I < 40 \text{ V}$; $V_I > 4.5 \text{ V}$; $5 \text{ mA} \leq I_Q \leq 200 \text{ mA}$
5.1.4	Output Voltage Adjustable Range ³⁾	$V_{Q,range}$	2.5	–	20	V	TLE42764GV, TLE42764DV; see Page 14
5.1.5	Dropout Voltage	V_{dr}	–	250	500	mV	TLE42764GV50, TLE42764DV50, TLE42764EV50; $I_Q = 250 \text{ mA}$ $V_{dr} = V_I - V_Q$ ²⁾
5.1.6	Dropout Voltage	V_{dr}	–	250	500	mV	TLE42764GV, TLE42764DV; $I_Q = 250 \text{ mA}$; $V_I > 4.5 \text{ V}$; $V_{dr} = V_I - V_Q$ ²⁾
5.1.7	Load Regulation	$\Delta V_{Q,lo}$	–	5	35	mV	$I_Q = 5 \text{ mA}$ to 400 mA ; $V_I = 6 \text{ V}$ TLE42764GV50, TLE42764DV50, TLE42764EV50; $V_I = 4.5 \text{ V}$ TLE42764GV, TLE42764DV

Table 4 Electrical Characteristics
 $V_I = 13.5 \text{ V}$; $T_j = -40 \text{ }^\circ\text{C}$ to $150 \text{ }^\circ\text{C}$; all voltages with respect to ground (unless otherwise specified)

Pos.	Parameter	Symbol	Limit Values			Unit	Measuring Condition
			Min.	Typ.	Max.		
5.1.8	Line Regulation	$\Delta V_{Q, li}$	–	15	25	mV	$V_I = 12 \text{ V}$ to 32 V $I_Q = 5 \text{ mA}$
5.1.9	Output Current Limitation	I_Q	400	600	1100	mA	²⁾
5.1.10	Power Supply Ripple Rejection ³⁾	$PSRR$	–	54	–	dB	$f_r = 100 \text{ Hz}$; $V_r = 0.5 \text{ Vpp}$
5.1.11	Temperature Output Voltage Drift ³⁾	$\frac{dV_Q}{dT}$	–	0.5	–	mV/K	–

Current Consumption

5.1.12	Current Consumption, Regulator Disabled	I_q	–	–	10	μA	$V_{EN} = 0 \text{ V}$ $T_j \leq 100 \text{ }^\circ\text{C}$
5.1.13	Quiescent Current $I_q = I_I - I_Q$	I_q	–	100	220	μA	$I_Q = 1 \text{ mA}$; $V_{EN} = 5 \text{ V}$
5.1.14	Current Consumption $I_q = I_I - I_Q$	I_q	–	5	10	mA	$I_Q = 250 \text{ mA}$; $V_{EN} = 5 \text{ V}$
5.1.15	Current Consumption $I_q = I_I - I_Q$	I_q	–	15	25	mA	$I_Q = 400 \text{ mA}$; $V_{EN} = 5 \text{ V}$

1) influence of resistor divider on precision neglected

2) Measured when the output voltage V_Q has dropped 100 mV from the nominal value obtained at $V_I = 13.5 \text{ V}$.

3) not subject to production test, specified by design

5.2 Typical Performance Characteristics Voltage Regulator

Current Consumption I_q versus Output Current I_Q

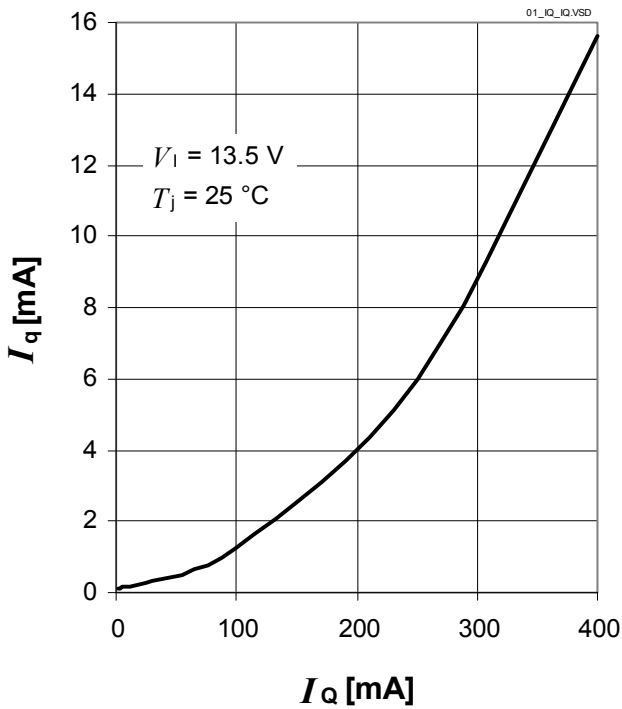

Current Consumption I_q versus Low Output Current I_Q

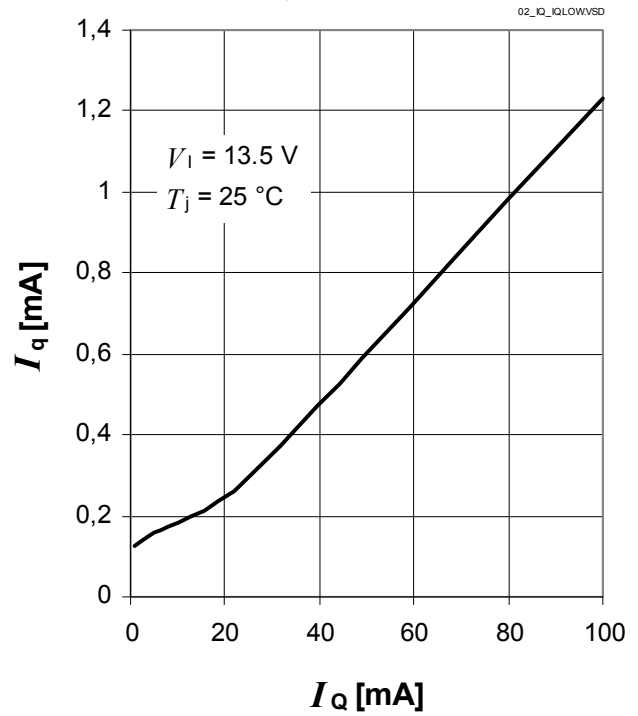

Output Voltage V_Q versus Junction Temperature T_j

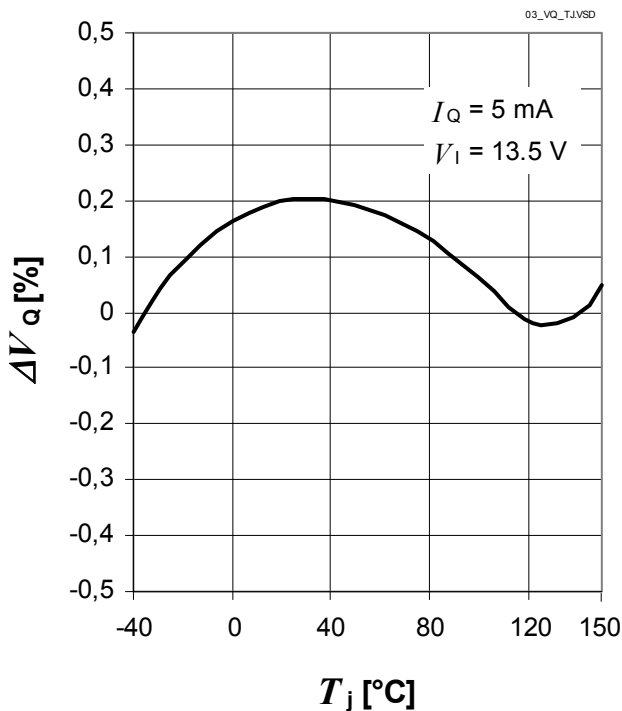

Dropout Voltage V_{dr} versus Output Current I_Q

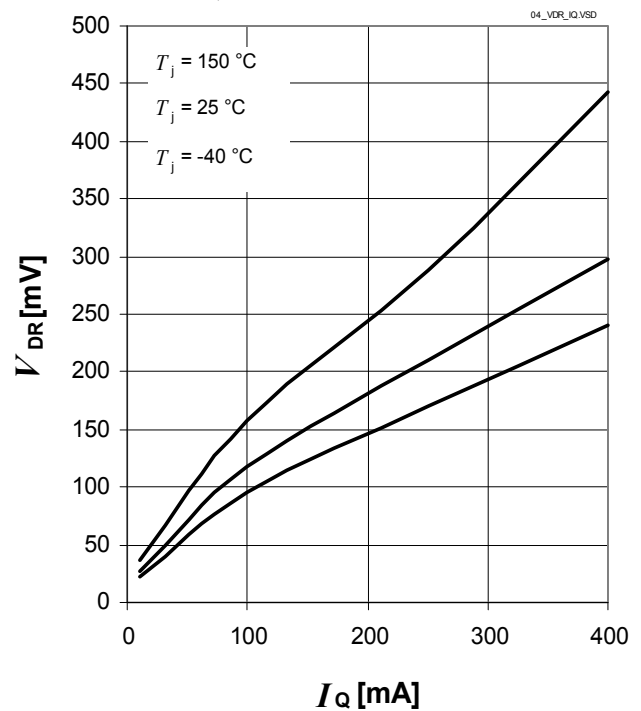

Dropout Voltage V_{dr} versus Junction Temperature

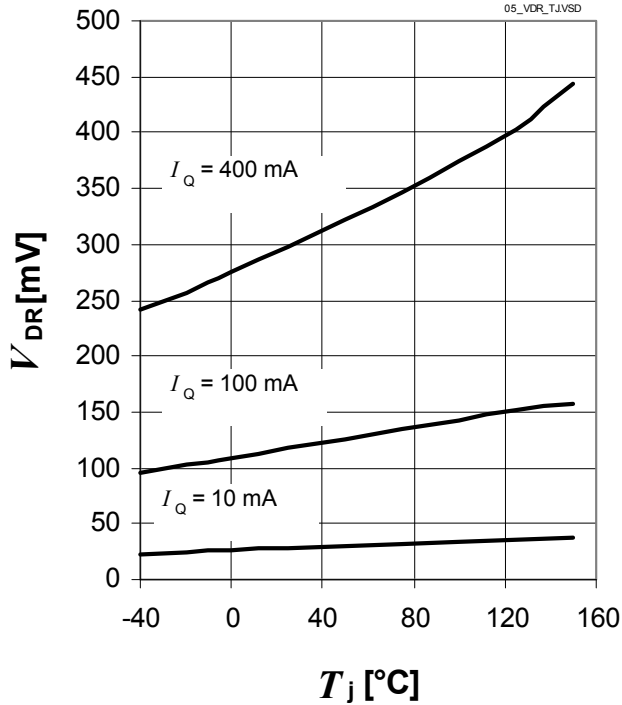

Maximum Output Current I_Q versus Input Voltage V_I

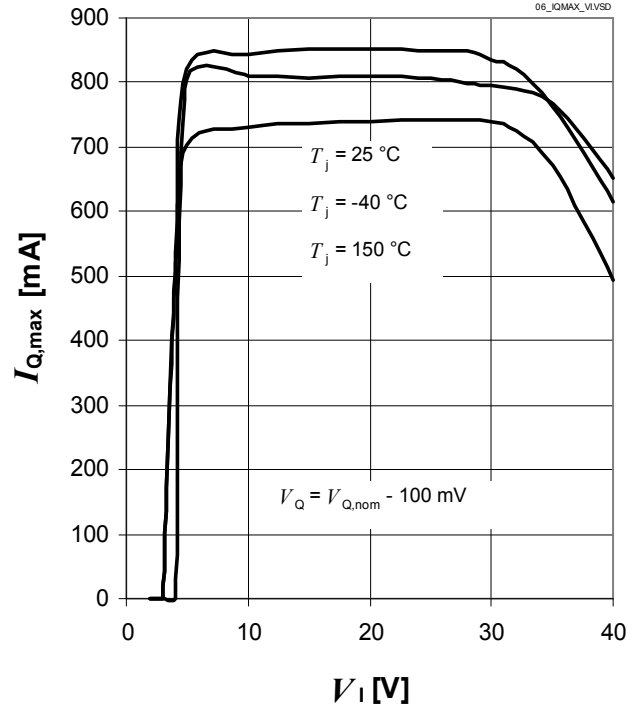

Region Of Stability: Output Capacitor's ESR $ESR(C_Q)$ versus Output Current I_Q

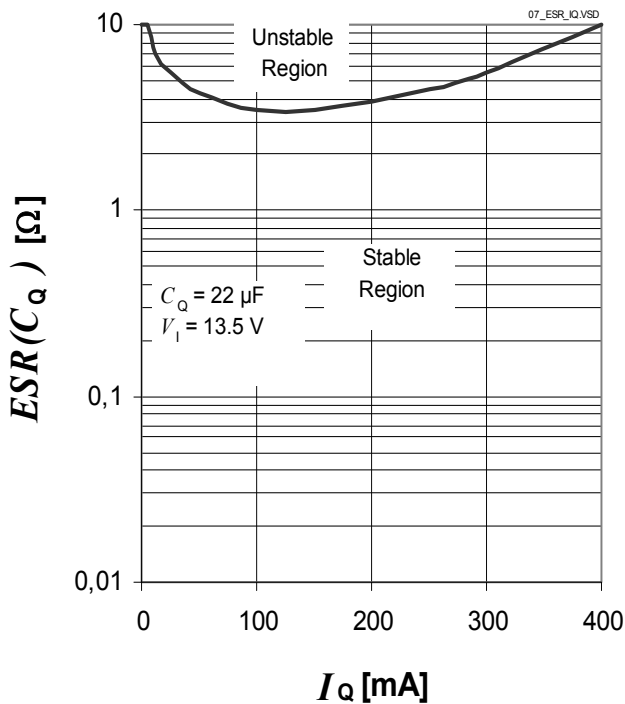

5.3 Electrical Characteristics Enable Function

The Enable Function allows disabling/enabling the regulator via the input pin EN. The regulator is turned on in case the pin EN is connected to a voltage higher than $V_{EN,H}$. This can be e.g. the battery voltage, whereby no additional pull-up resistor is needed. The regulator can be turned off by connecting the pin EN to a voltage less than $V_{EN,L}$, e.g. GND.

Table 5 Electrical Characteristics Enable

$V_I=13.5\text{ V}$; $T_j = -40\text{ °C}$ to 150 °C ; all voltages with respect to ground, positive current flowing into pin (unless otherwise specified)

Pos.	Parameter	Symbol	Limit Values			Unit	Measuring Condition
			Min.	Typ.	Max.		
5.3.16	High Level Input Voltage	$V_{EN,H}$	3.5	–	–	V	$V_Q \geq 4.9\text{ V}$
5.3.17	Low Level Input Voltage	$V_{EN,L}$	–	–	0.5	V	$V_Q \leq 0.1\text{ V}$
5.3.18	High Level Input Current	$I_{EN,H}$	5	10	20	μA	$V_{EN} = 5\text{ V}$

5.4 Typical Performance Characteristics Enable Function

Enabled Input Current I_{EN} versus Input Voltage V_I , EN=Off

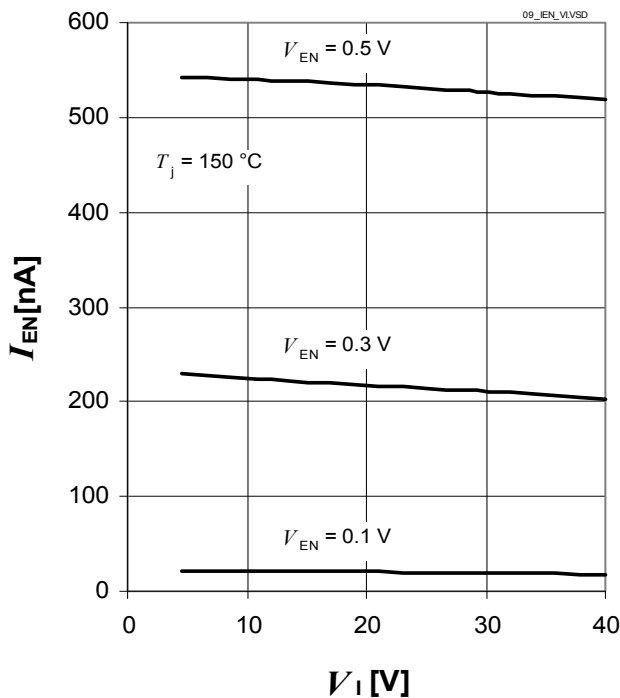

Enabled Input Current I_{EN} versus Enabled Input Voltage V_{EN}

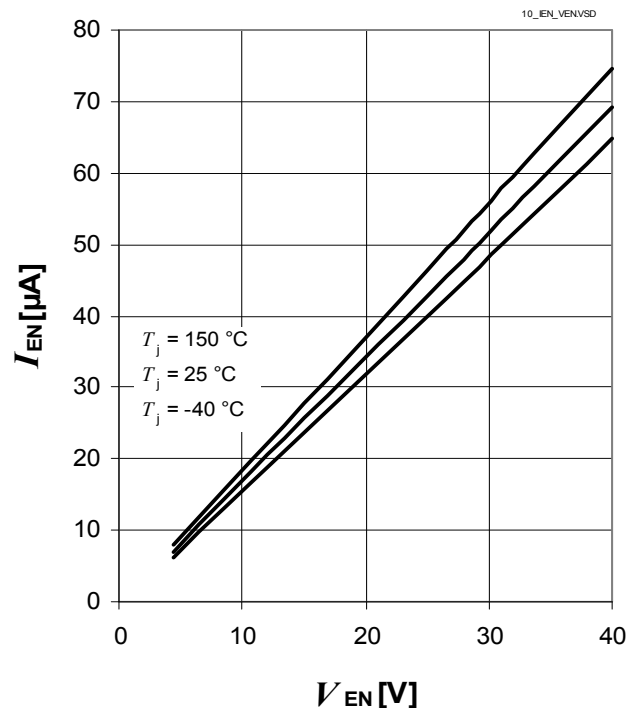

6 Application Information

Note: The following information is given as a hint for the implementation of the device only and shall not be regarded as a description or warranty of a certain functionality, condition or quality of the device.

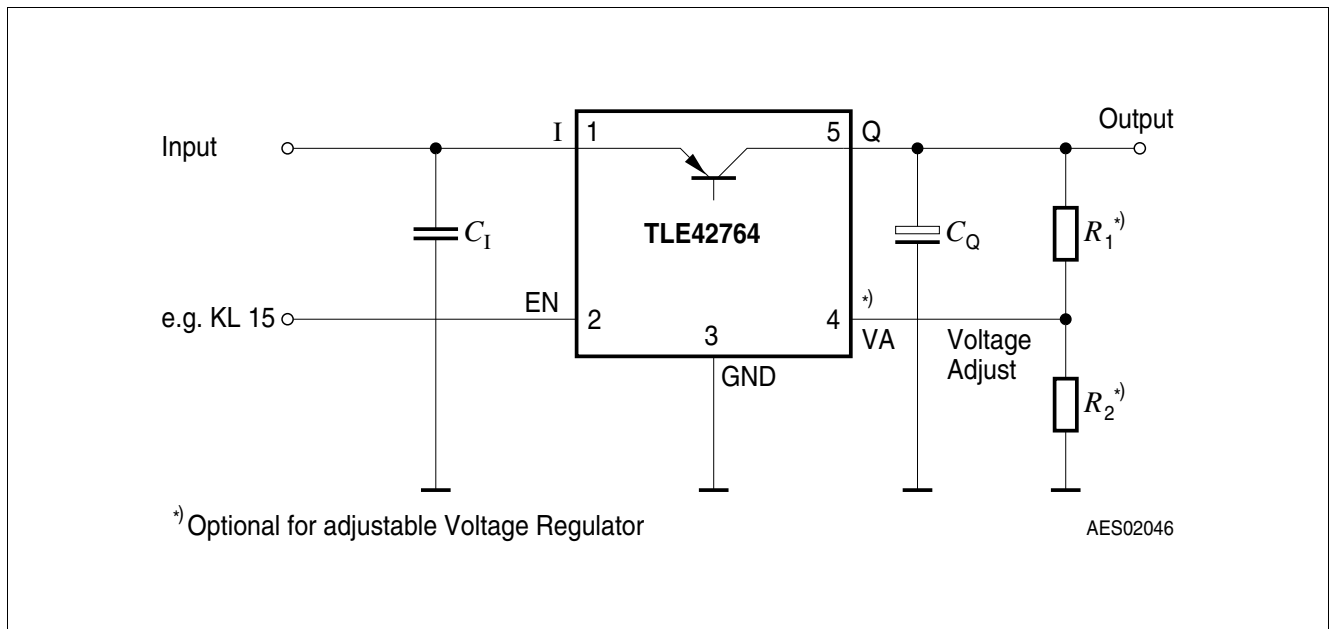

Figure 4 Application Diagram

A typical application circuit of the TLE42764 is shown in [Figure 4](#). It shows a generic configuration of the voltage regulator, with the recommendable minimum number of components one should use. Theoretically, if there is no risk of high frequency noise at all, even the small input filter capacitor can be omitted. For a normal operation mode of the device the only required device is the output capacitor, for the TLE42764GV and the TLE42764DV additionally the resistor divider. However, depending on the application's environment, additional components like an input buffer capacitor or a reverse polarity protection diode can be considered as well.

Input Filter Capacitor

A small ceramic capacitor (e.g. 100nF in [Figure 4](#)) at the device's input helps filtering high frequency noise. To reach the best filter effect, this capacitor should be placed as close as possible to the device's input pin. The input filter capacitor does not have an influence on the stability of the device's regulation loop.

Output Capacitor C_Q

The output capacitor is the only external component that is required in any case as it is a part of the device's regulating loop. To maintain stability of this loop, the TLE42764 requires an output capacitor respecting the values given in "[Functional Range](#)" on [Page 7](#).

Adjusting the Output Voltage of Variable Output Regulators TLE42764GV, TLE42764DV

The output voltage of the TLE42764GV and the TLE42764DV can be adjusted between 2.5 V and 20 V by an external resistor divider, connected to the voltage adjust pin VA.

The pin VA is connected to the error amplifier comparing the voltage at this pin with the internal reference voltage of typically 2.5 V.

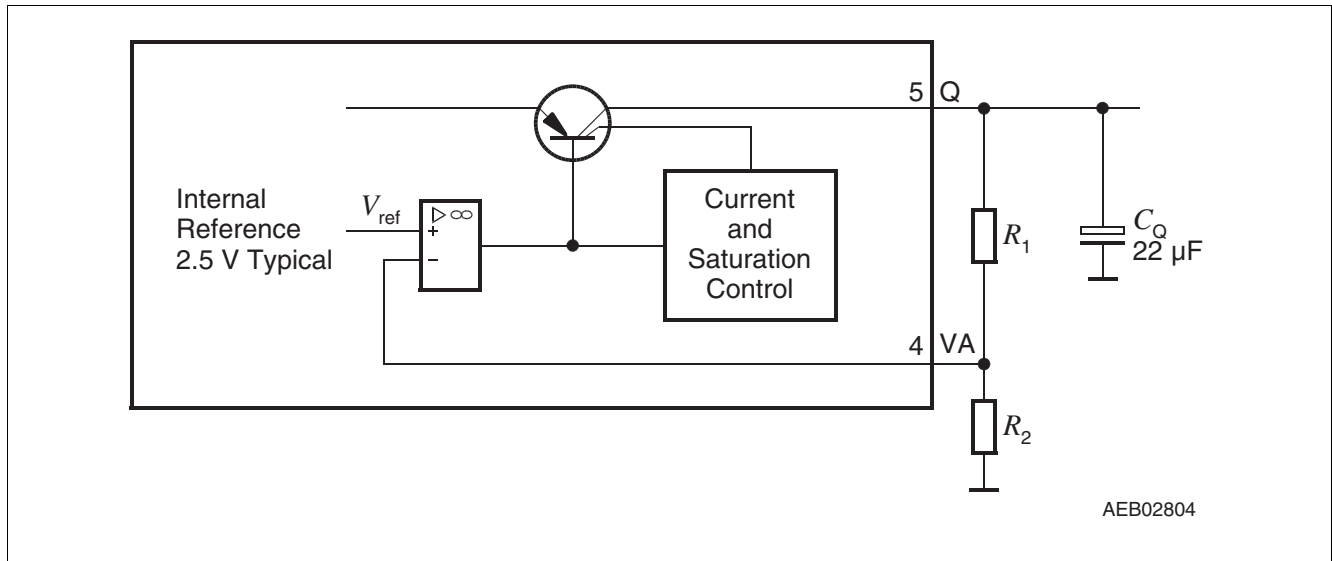

Figure 5 External Components at Output for Variable Voltage Regulator

The output voltage can be easily calculated, neglecting the current flowing into the VA pin:

$$V_Q = \frac{R_1 + R_2}{R_2} \times V_{ref}$$

where

$$R_2 < 50 \text{ k}\Omega \quad \text{to neglect the current flowing into the VA pin,}$$

with:

- V_{ref} : internal reference voltage, typically 2.5V
- R_1 : resistor between regulator output Q and voltage adjust pin VA
- R_2 : resistor between voltage adjust pin VA and GND

For a 2.5 V output voltage the output pin Q has to be directly connected to the adjust pin VA.

Take into consideration, that the accuracy of the resistors R_1 and R_2 adds an additional error to the output voltage tolerance.

7 Package Outlines

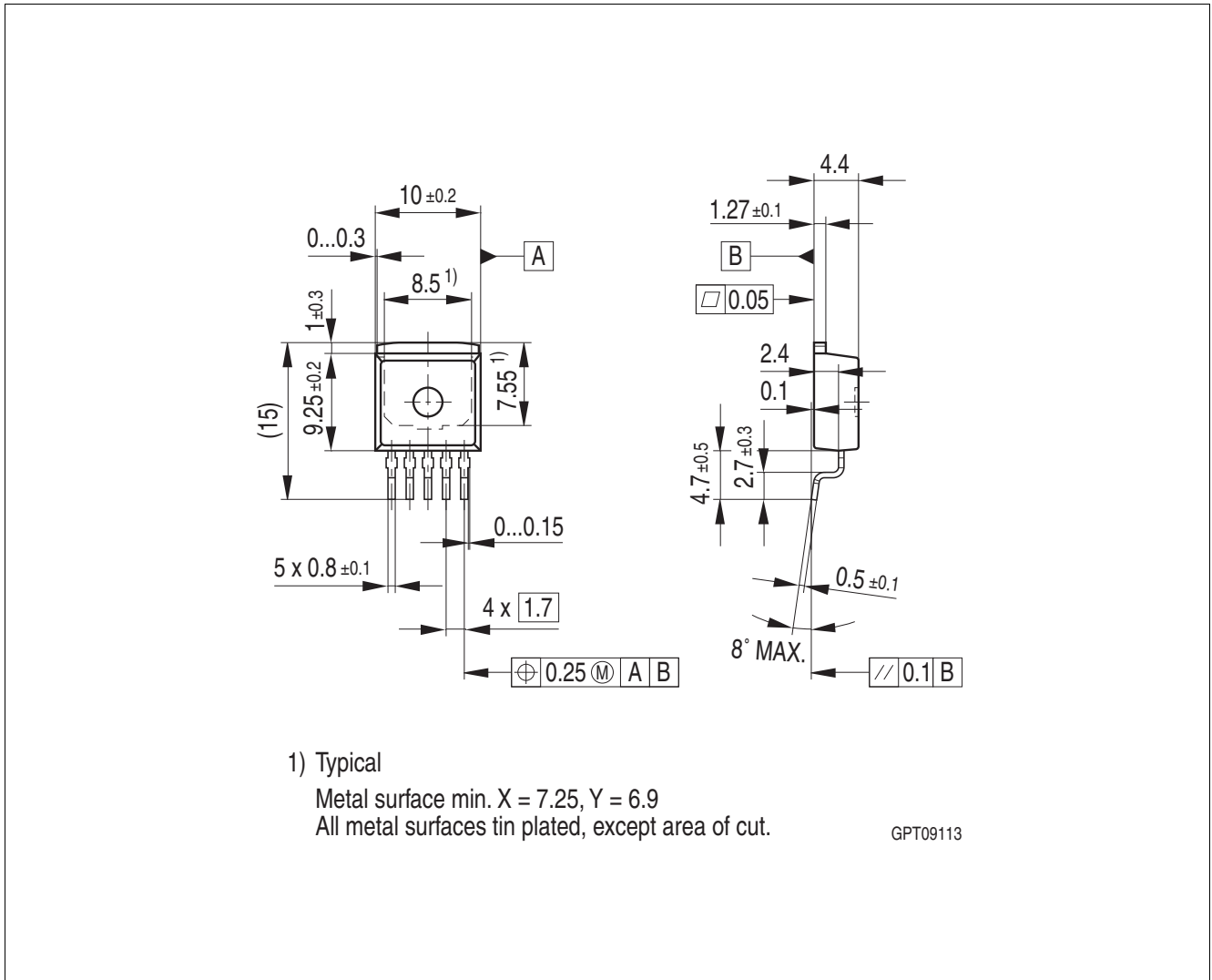

Figure 6 PG-TO263-5

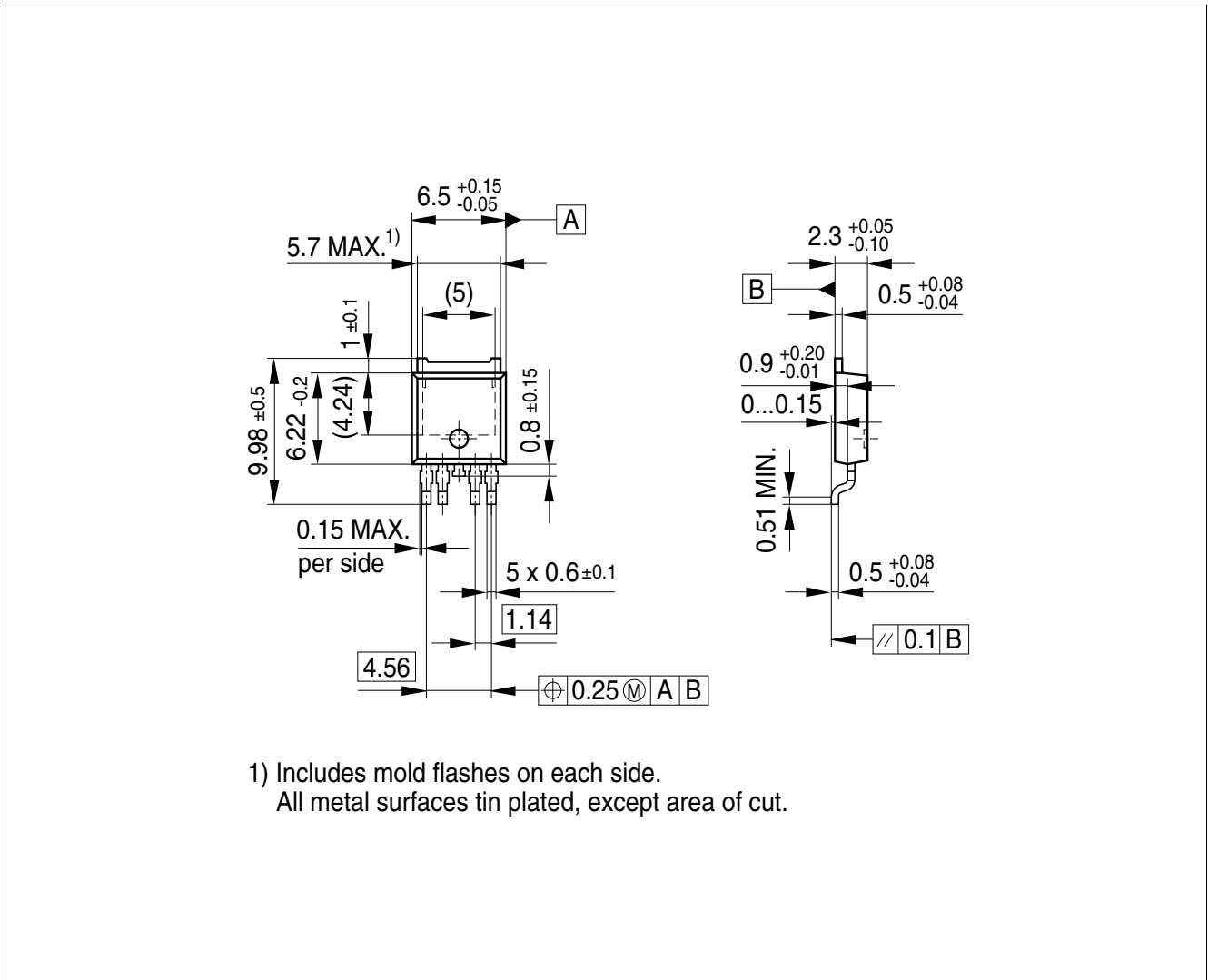

Figure 7 PG-TO252-5

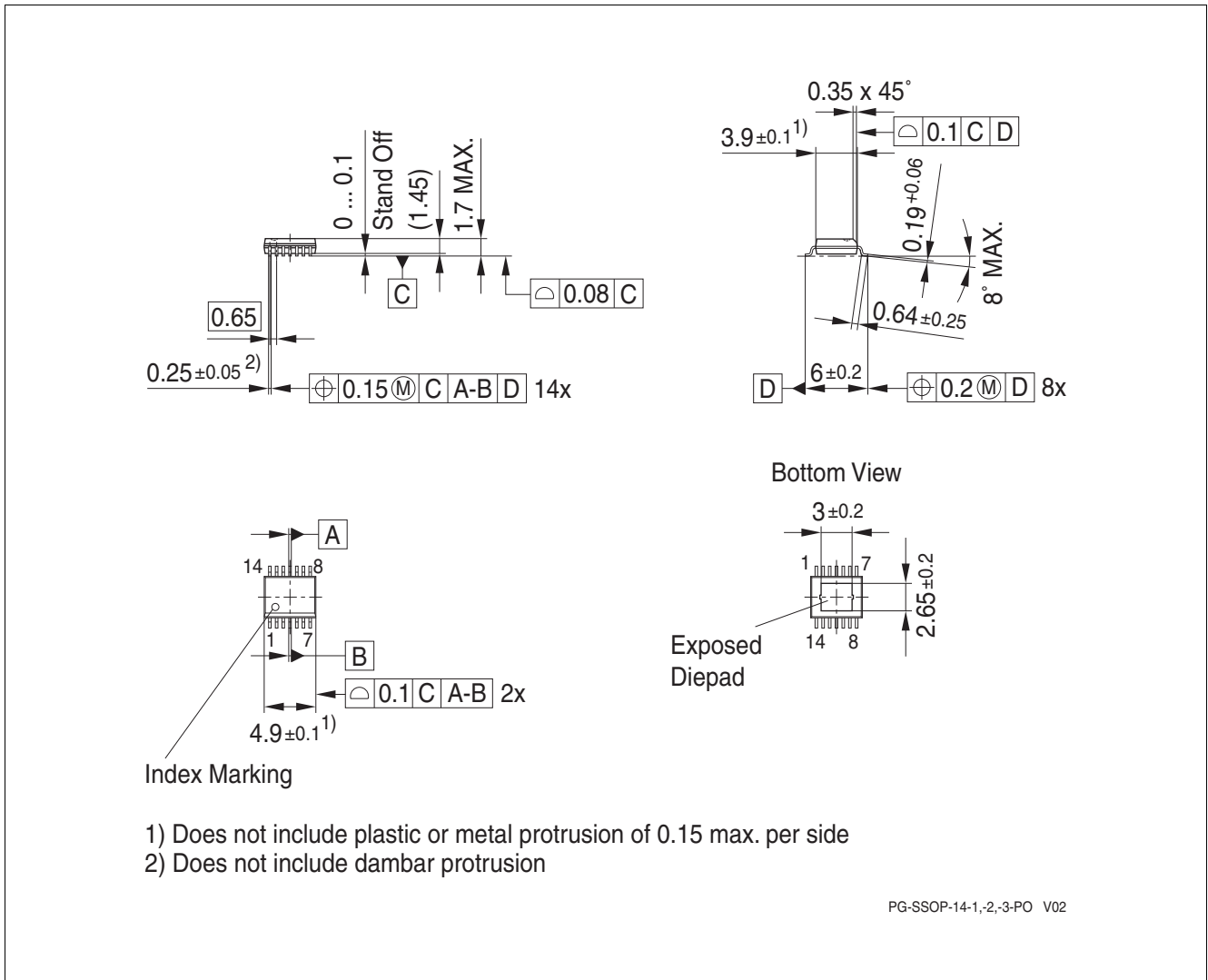

Figure 8 PG-SSOP-14 exposed pad

Green Product (RoHS compliant)

To meet the world-wide customer requirements for environmentally friendly products and to be compliant with government regulations the device is available as a green product. Green products are RoHS-Compliant (i.e Pb-free finish on leads and suitable for Pb-free soldering according to IPC/JEDEC J-STD-020).

For further information on alternative packages, please visit our website:
<http://www.infineon.com/packages>.

Dimensions in mm

8 Revision History

Revision	Date	Changes
1.3	2013-07-30	Split of the Accuracy Specification for the adjustable variants TLE42764GV and TLE42764DV (5.1.3) into two different conditions. For high input voltages up to 40V and output current up to 200mA the accuracy is specified with +-2%. For input voltages up to 28V, the output current is allowed to go up to 400mA to achieve an accuracy of +-2% according to the specification.
1.2	2011-02-15	Updated Version final Data Sheet: 5V Version TLE42764EV50 in PG-SSOP-14 exposed pad package and all related description added
1.1	2009-10-09	Updated Version final Data Sheet: 5V Versions in PG-TO252-5 and PG-TO263-5 package and all related description added
		In “Features” on Page 2 in text “and 5 V Fixed “added
		In “Description” on Page 2 “or 5 V fixed “added
		In table on bottom of page “Overview” on Page 2 2 product versions including package and marking added
		In “Functional Range” on Page 7 Item 4.2.1 added
		In “Electrical Characteristics Voltage Regulator” on Page 9 Item 5.1.1, Item 5.1.2 and Item 5.1.5 added; In Conditions of Item 5.1.7 “ $V_I = 6\text{ V}$ TLE42764GV50, TLE42764DV50;” added
1.0	2008-01-14	Initial Version final Data Sheet

Edition 2013-07-30

**Published by
Infineon Technologies AG
81726 Munich, Germany**

**© 2013 Infineon Technologies AG
All Rights Reserved.**

Legal Disclaimer

The information given in this document shall in no event be regarded as a guarantee of conditions or characteristics. With respect to any examples or hints given herein, any typical values stated herein and/or any information regarding the application of the device, Infineon Technologies hereby disclaims any and all warranties and liabilities of any kind, including without limitation, warranties of non-infringement of intellectual property rights of any third party.

Information

For further information on technology, delivery terms and conditions and prices, please contact the nearest Infineon Technologies Office (www.infineon.com).

Warnings

Due to technical requirements, components may contain dangerous substances. For information on the types in question, please contact the nearest Infineon Technologies Office.

Infineon Technologies components may be used in life-support devices or systems only with the express written approval of Infineon Technologies, if a failure of such components can reasonably be expected to cause the failure of that life-support device or system or to affect the safety or effectiveness of that device or system. Life support devices or systems are intended to be implanted in the human body or to support and/or maintain and sustain and/or protect human life. If they fail, it is reasonable to assume that the health of the user or other persons may be endangered.

X-ON Electronics

Largest Supplier of Electrical and Electronic Components

Click to view similar products for [LDO Voltage Regulators](#) category:

Click to view products by [Infineon](#) manufacturer:

Other Similar products are found below :

[M38D29FFHP#U1](#) [702103A](#) [717726C](#) [742457H](#) [MP20051DN-LF-Z](#) [R5F111PGGFB#30](#) [AP7363-SP-13](#) [NCP103AMX285TCG](#)
[NCV8664CST33T3G](#) [NCV8752AMX28TCG](#) [L9454](#) [AP7362-HA-7](#) [LX13043CLD](#) [TCR3DF185,LM\(CT](#) [TCR3DF24,LM\(CT](#)
[TCR3DF285,LM\(CT](#) [TCR3DF31,LM\(CT](#) [TCR3DF45,LM\(CT](#) [TLF4949EJ](#) [L9708](#) [L970813TR](#) [030014BB](#) [059985X](#) [EAN61387601](#)
[EAN61573601](#) [NCP121AMX173TCG](#) [NCP4687DH15T1G](#) [NCV8703MX30TCG](#) [701326R](#) [702087BB](#) [755078E](#) [TCR2EN28,LF\(S](#)
[LM1117DT-1.8/NO](#) [LT1086CM#TRPBF](#) [AZ1085S2-1.5TRE1](#) [MAX15101EWL+T](#) [NCV8170AXV250T2G](#) [SCD337BTG](#)
[TCR3DF27,LM\(CT](#) [TCR3DF19,LM\(CT](#) [TCR3DF125,LM\(CT](#) [TCR2EN18,LF\(S](#) [MAX15103EWL+T](#) [TS2937CZ-5.0 C0](#) [MAX8878EUK30-](#)
[T](#) [MAX663CPA](#) [NCV4269CPD50R2G](#) [NCV8716MT30TBG](#) [AZ1117IH-1.2TRG1](#) [MP2013GQ-P](#)