

# OPTIREG™ Linear TLE4278G

## 5 V low drop fixed voltage regulator



### Features

- Output voltage tolerance  $\leq \pm 2\%$
- Very low current consumption
- Separated reset and watchdog output
- Low-drop voltage
- Watchdog
- Adjustable watchdog activating threshold
- Adjustable reset threshold
- Overtemperature protection
- Reverse polarity protection
- Short-circuit proof
- Suitable for use in automotive electronics
- Wide temperature range
- Green Product (RoHS compliant)

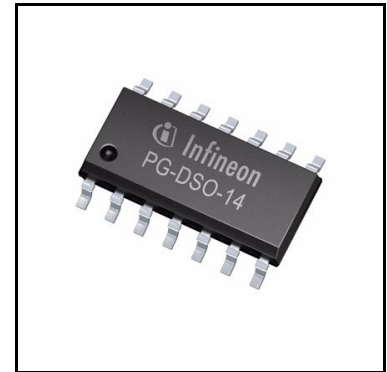

### Potential applications

General automotive applications.

### Product validation

Qualified for automotive applications. Product validation according to AEC-Q100/101.

### Description

The OPTIREG™ Linear TLE4278G is a monolithic integrated low-drop fixed output voltage regulator supplying loads up to 200 mA. The IC is available in a PG-DSO-14 package. It is designed to supply microprocessor systems under the severe conditions of automotive applications and therefore equipped with additional protection functions against over- load, short circuit and overtemperature. The TLE4278 can also be used in other applications where a stabilized voltage is required.

Type	Package	Marking
TLE4278G	PG-DSO-14	TLE4278G

## Table of contents

	<b>Features</b> .....	<b>1</b>
	<b>Potential applications</b> .....	<b>1</b>
	<b>Product validation</b> .....	<b>1</b>
	<b>Description</b> .....	<b>1</b>
	<b>Table of contents</b> .....	<b>2</b>
<b>1</b>	<b>Block diagram</b> .....	<b>3</b>
<b>2</b>	<b>Pin configuration</b> .....	<b>4</b>
<b>3</b>	<b>General product characteristics</b> .....	<b>5</b>
3.1	Absolute maximum ratings .....	5
3.2	Functional range .....	6
3.3	Thermal resistance .....	6
<b>4</b>	<b>Functional description</b> .....	<b>7</b>
4.1	Electrical characteristics .....	8
4.2	Test circuit .....	10
4.3	Typical performance characteristics .....	11
<b>5</b>	<b>Application information</b> .....	<b>13</b>
5.1	Input, output .....	13
5.2	Reset timing .....	14
5.3	Reset switching threshold .....	15
5.4	Watchdog activating .....	16
5.5	Watchdog timing .....	17
5.6	Hints for unused pins .....	18
<b>6</b>	<b>Package information</b> .....	<b>19</b>
<b>7</b>	<b>Revision history</b> .....	<b>20</b>

**Block diagram**

**1 Block diagram**

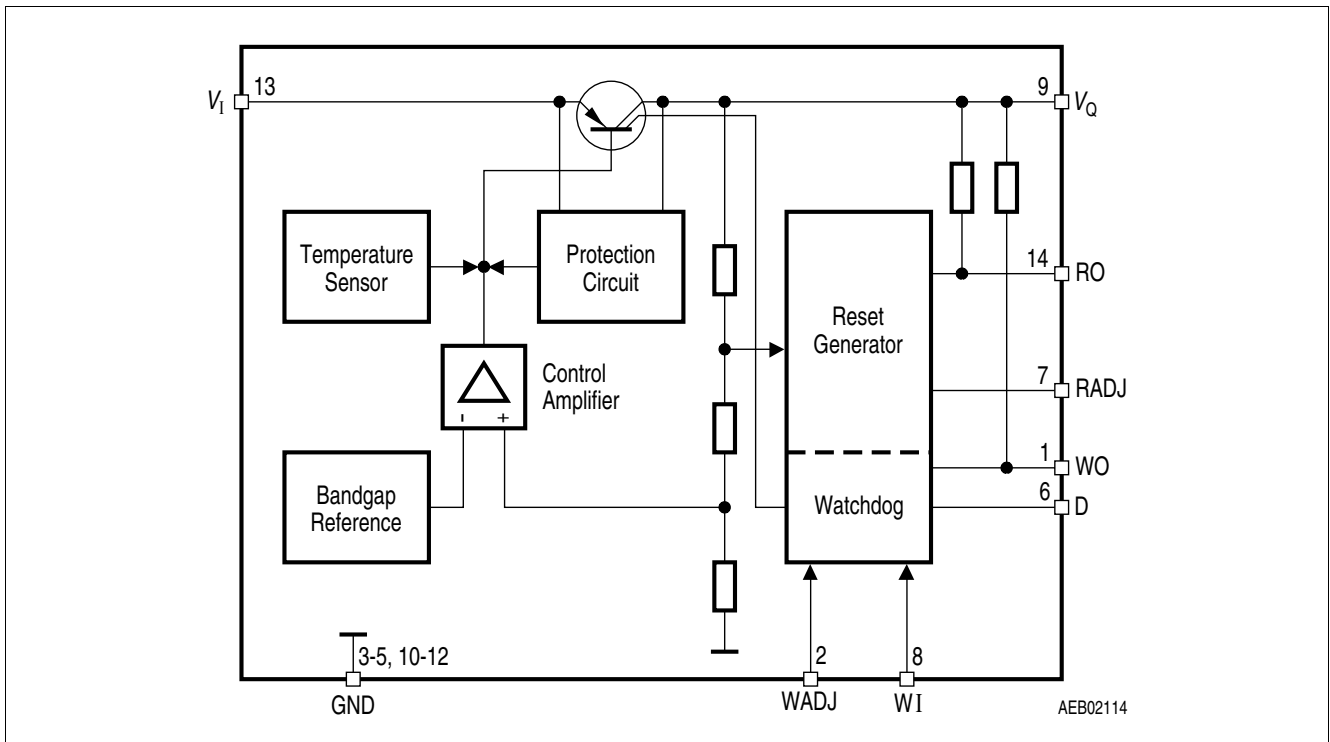

**Figure 1 Block diagram**

**Pin configuration**

**2 Pin configuration**

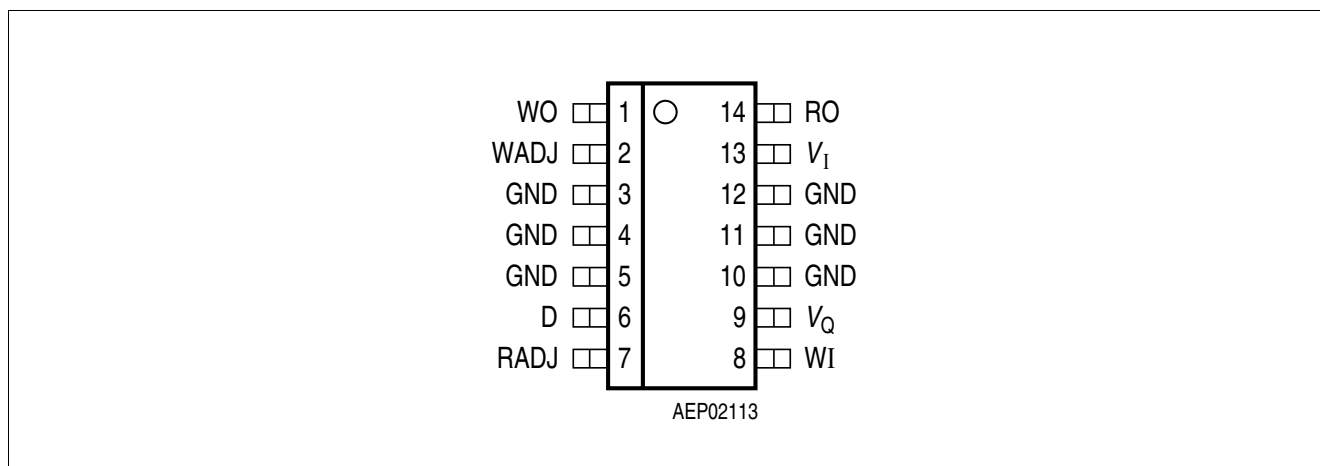

**Figure 2 Pin configuration PG-DSO-14 (top view)**

**Table 1 Pin definitions and functions**

Pin	Symbol	Function
1	WO	<b>Watchdog output;</b> the open collector output is connected to the 5 V output via an integrated resistor of 30 kΩ.
2	WADJ	<b>Watchdog adjust;</b> an external resistor to GND determines the watchdog activating threshold.
3, 4, 5, 10, 11, 12	GND	<b>Ground</b>
6	D	<b>Reset delay;</b> connect a capacitor to ground for delay time adjustment.
7	RADJ	<b>Reset switching threshold adjust;</b> for setting the switching threshold, connect a voltage divider from output to ground. If this input is connected to ground, the reset is triggered at the internal threshold.
8	WI	<b>Watchdog input;</b> rising edge-triggered input for monitoring a microcontroller.
9	Q	<b>5 V output voltage;</b> block to ground with min. 10 μF capacitor, ESR ≤ 5 Ω.
13	I	<b>Input voltage;</b> block to ground directly on the IC with ceramic capacitor.
14	RO	<b>Reset output;</b> the open collector output is connected to the 5 V output via an integrated resistor of 30 kΩ.

General product characteristics

### 3 General product characteristics

#### 3.1 Absolute maximum ratings

**Table 2 Absolute maximum ratings**

$T_j = -40^\circ\text{C}$  to  $150^\circ\text{C}$

Parameter	Symbol	Values			Unit	Note or Test Condition
		Min.	Typ.	Max.		
<b>Input voltage I</b>						
Voltage	$V_I$	-42	-	45	V	-
Current	$I_I$	-	-	-	mA	Internally limited
<b>Output voltage Q</b>						
Voltage	$V_Q$	-1	-	25	V	-
Current	$I_Q$	-	-	-	mA	Internally limited
<b>Reset output RO</b>						
Voltage	$V_{RO}$	-0.3	-	25	V	-
Current	$I_{RO}$	-5	-	5	mA	-
<b>Reset delay D</b>						
Voltage	$V_D$	-0.3	-	7	V	-
Current	$I_D$	-2	-	2	mA	-
<b>Reset switching threshold adjust RADJ</b>						
Voltage	$V_{RADJ}$	-0.3	-	7	V	-
Current	$I_{RADJ}$	-	-	-	mA	Internally limited
<b>Watchdog input WI</b>						
Voltage	$V_{WI}$	-0.3	-	7	V	-
Current	$I_{WI}$	-	-	-	mA	Internally limited
<b>Watchdog output WO</b>						
Voltage	$V_{WO}$	-0.3	-	25	V	-
Current	$I_{WO}$	-5	-	5	mA	-
<b>Watchdog adjust WADJ</b>						
Voltage	$V_{WADJ}$	-0.3	-	7	V	-
Current	$I_{WADJ}$	-	-	-	mA	Internally limited
<b>Ground GND</b>						
Current	$I_{GND}$	-100	-	50	mA	-
<b>Temperatures</b>						
Junction temperature	$T_j$	-50	-	150	$^\circ\text{C}$	-
Storage temperature	$T_{stg}$	-50	-	150	$^\circ\text{C}$	-

**General product characteristics**

*Note: ESD protection according to MIL Std. 883: ±2 kV.  
 Maximum ratings are absolute ratings; exceeding any one of these values may cause irreversible damage to the integrated circuit.*

**3.2 Functional range**

**Table 3 Functional range**

Parameter	Symbol	Values			Unit	Note or Test Condition
		Min.	Typ.	Max.		
Input voltage	$V_I$	5.5	–	45	V	–
Junction temperature	$T_j$	-40	–	150	°C	–

*Note: In the functional range the functions given in the circuit description are fulfilled.*

**3.3 Thermal resistance**

**Table 4 Thermal resistance**

Parameter	Symbol	Values			Unit	Note or Test Condition
		Min.	Typ.	Max.		
Junction ambient	$R_{thj-a}$	–	–	80	K/W	<sup>1)</sup>
Junction pin	$R_{thj-pin}$	–	–	30	K/W	Measured to pin 4

1) Package mounted on PCB 80 × 80 × 1.5 mm<sup>3</sup>; 35 μm Cu; 5 μm Sn; Heat Sink Area 6 cm<sup>2</sup>; zero airflow.

## Functional description

### 4 Functional description

The TLE4278 is a monolithic integrated low-drop fixed output voltage regulator supplying loads up to 200 mA. An input voltage  $V_I$  in the range of  $5.5 \text{ V} \leq V_I \leq 45 \text{ V}$  is regulated to  $V_{Q,\text{nom}} = 5 \text{ V}$  with an accuracy of  $\pm 2\%$ .

The device operates in the wide temperature range of  $T_j = -40^\circ\text{C}$  to  $150^\circ\text{C}$ .

Two additional features are implemented in the TLE4278 a load dependent watchdog function as well as a sophisticated reset function including power on reset, under voltage reset, adjustable reset delay time and adjustable reset switching threshold.

The watchdog function monitors the microcontroller, including time base failures. In case of a missing rising edge within a certain pulse repetition time the watchdog output is set to “low”. Programming of the max. repetition time can be done easily by an external reset delay capacitor. To prevent a reset in case of missing pulses, the watchdog output WO is separate from the reset output RO for the TLE4278. The watchdog output can be used as an interrupt signal for the microcontroller. In any case it is possible to connect pin WO and pin RO externally.

When the controller is set to sleep mode or low power mode its current consumption drops and no watchdog pulses are created. In order to avoid unnecessary wake-up signals due to missing pulses at pin WI the watchdog feature can be disabled as a function of the load current. The switch off threshold is set by an external resistor to pin WADJ. The watchdog function can also be used as a timer, which periodically wakes up the controller. Therefore the pin WADJ must be connected to the output Q.

The power on reset feature is necessary for a defined start of the microprocessor when switching on the application. The reset signal at pin RO goes “high” after a certain delay timed  $t_{rd}$  when the output voltage of the regulator has surpassed the reset threshold. The delay time is set by the external delay capacitor. An under voltage reset circuit supervises the output voltage. In case  $V_Q$  falls below the reset threshold the reset output is set to “low” after a short reset reaction time  $t_{rr}$ . The reset “low” signal is generated down to an output voltage  $V_Q$  of 1 V. In addition the reset switching threshold can be adjusted by an external voltage divider. This feature is useful with microprocessors which ensure a safe operation down to voltages below the internally set reset threshold of 4.65 V typical.

**Functional description**

**4.1 Electrical characteristics**

**Table 5 Electrical characteristics**

$V_I = 13.5\text{ V}$ ;  $-40^\circ\text{C} \leq T_j \leq 125^\circ\text{C}$  (unless otherwise specified)

Parameter	Symbol	Values			Unit	Note or Test Condition
		Min.	Typ.	Max.		
Output voltage	$V_Q$	4.90	5.00	5.10	V	$0\text{ mA} \leq I_Q \leq 150\text{ mA}$ ; $6\text{ V} \leq V_I \leq 28\text{ V}$
Output voltage	$V_Q$	4.8	5.0	5.2	V	$1\text{ mA} \leq I_Q \leq 50\text{ mA}$ ; $28\text{ V} \leq V_I \leq 45\text{ V}$
Output current limiting	$I_Q$	200	400	–	mA	$V_Q = 4.8\text{ V}$
Current consumption $I_q = I_I - I_Q$	$I_{q,o}$	–	180	200	$\mu\text{A}$	$T_j = 25^\circ\text{C}$ ; $I_Q = 0\text{ mA}$
Current consumption $I_q = I_I - I_Q$	$I_{q,o}$	–	210	230	$\mu\text{A}$	$I_Q = 0\text{ mA}$ ; $T_j = 85^\circ\text{C}$
Current consumption $I_q = I_I - I_Q$	$I_{q,150}$	–	5	12	mA	$I_Q = 150\text{ mA}$
Drop voltage $V_{DR} = V_I - V_Q$	$V_{dr}$	–	0.25	0.5	V	$I_Q = 150\text{ mA}^{1)}$
Load regulation	$\Delta V_{Q,lo}$	-30	-5	–	mV	$I_Q = 5\text{ to }150\text{ mA}$ ; $V_I = 6\text{ V}$
Line regulation	$\Delta V_{Q,li}$	–	5	20	mV	$V_I = 6\text{ to }28\text{ V}$ ; $I_Q = 5\text{ mA}$

**Reset generator**

Reset threshold	$V_{Q,rt}$	4.5	4.65	4.8	V	RADJ connected to GND
Reset headroom	$\Delta V_{Q,rt} = (V_{Q,nom} - V_{Q,rt})$	180	350	–	mV	$I_Q = 10\text{ mA}$
Reset adjust threshold	$V_{RADJ,th}$	1.28	1.35	1.45	V	$V_Q \geq 3.5\text{ V}$
Reset low voltage	$V_{RO,l}$	–	0.20	0.40	V	$R_{ext} = 10\text{ k}\Omega$ to $V_Q$ ; $V_Q \geq 1\text{ V}$
Reset high voltage	$V_{RO,h}$	4.5	–	–	V	–
Reset pull-up	$R_{RO}$	20	30	45	k $\Omega$	Internal connected to $V_Q$
Charging current	$I_{D,c}$	2	5	8	$\mu\text{A}$	$V_D = 1.0\text{ V}$
Upper timing threshold	$V_{DU}$	1.5	1.9	2.3	V	–
Lower reset timing threshold	$V_{DRL}$	0.2	0.3	0.4	V	–
Delay time	$t_{rd}$	12	20	28	ms	$C_D = 47\text{ nF}$
Reset reaction time	$t_{rr}$	0.4	1.0	2.0	$\mu\text{s}$	$C_D = 47\text{ nF}$



**Functional description**

**Table 5 Electrical characteristics (cont'd)**

$V_I = 13.5\text{ V}$ ;  $-40^\circ\text{C} \leq T_j \leq 125^\circ\text{C}$  (unless otherwise specified)

Parameter	Symbol	Values			Unit	Note or Test Condition
		Min.	Typ.	Max.		
<b>Watchdog</b>						
Activating threshold	$V_{WADJ,th}$	1.28	1.35	1.45	V	Voltage at WADJ
Current ratio	$I_Q/I_{WADJ}$	650	720	800	–	$I_Q \leq 10\text{ mA}$
Slew rate	$dV_{WI}/dt$	5	–	–	V/ $\mu\text{s}$	From 20% up to 80% $V_Q$
Watchdog low voltage	$V_{WOL}$	–	0.2	0.4	V	$R_{ext} > 10\text{ k}\Omega$ to $V_Q$
Watchdog high voltage	$V_{WOH}$	4.5	–	–	V	–
Watchdog pull-up	$R_{WO}$	20	30	45	k $\Omega$	Internal connected to $V_Q$
Charge current	$I_{D,wc}$	2	5	8	$\mu\text{A}$	$V_D = 1.0\text{ V}$
Discharge current	$I_{D,wd}$	0.6	1.3	2.0	$\mu\text{A}$	$V_D = 1.0\text{ V}$
Upper timing threshold	$V_{DU}$	1.5	1.9	2.3	V	–
Lower watchdog timing threshold	$V_{DWL}$	0.5	0.7	0.9	V	–
Watchdog output pulse period	$T_{WD,p}$	42	60	80	ms	$C_d = 47\text{ nF}$
Watchdog output low time	$t_{WD,l}$	7	13	19	ms	$V_Q > V_{RT}$
Watchdog trigger time	$T_{WI,tr}$	35	47	61	ms	$C_d = 47\text{ nF}$

1) Measured when the output voltage  $V_Q$  has dropped 100 mV from the nominal value.

**Functional description**

**4.2 Test circuit**

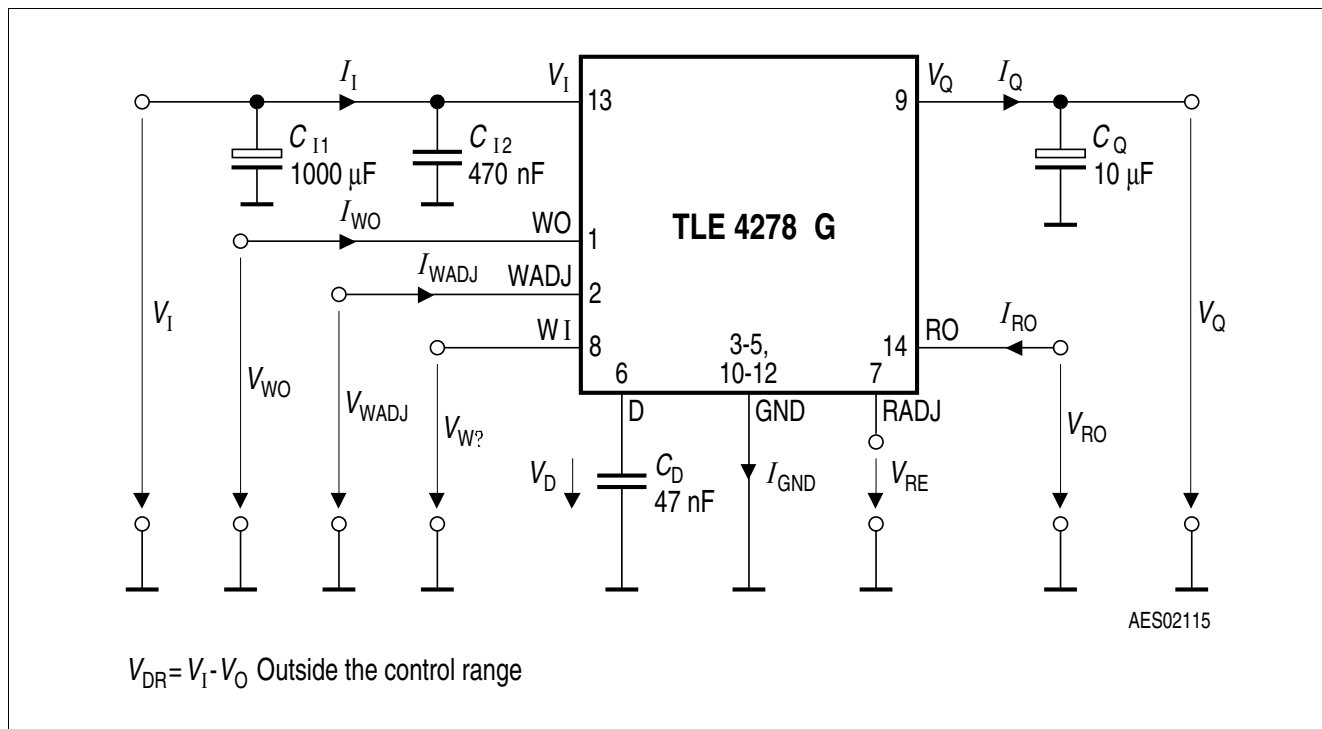
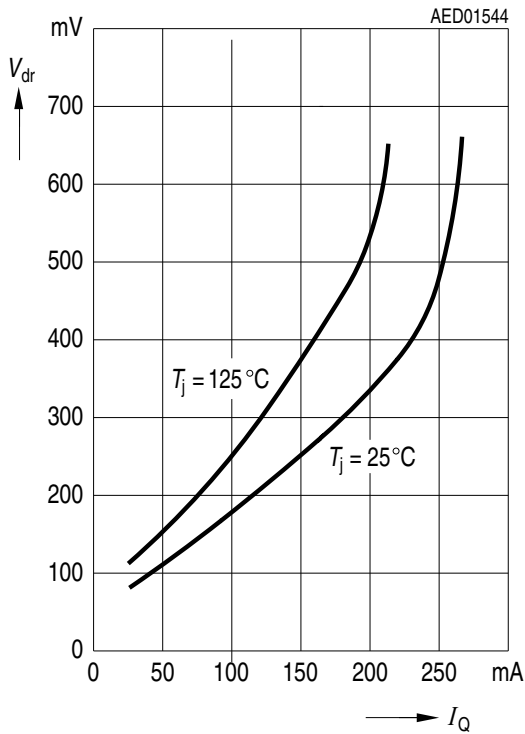

**Figure 3 Test circuit**

**Functional description**

**4.3 Typical performance characteristics**

**Drop voltage  $V_{dr}$  versus output current  $I_Q$**



**Current consumption  $I_q$  versus output current  $I_Q$**

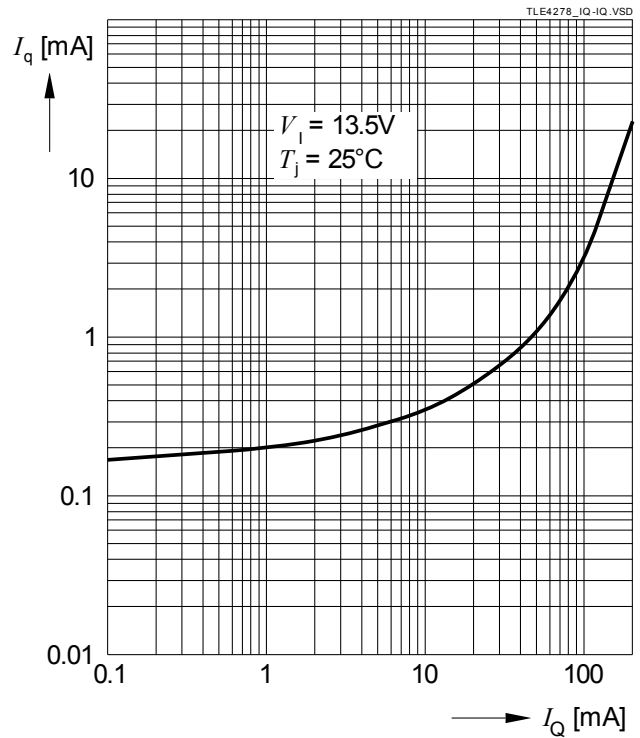

**Current consumption  $I_q$  versus input voltage  $V_i$**

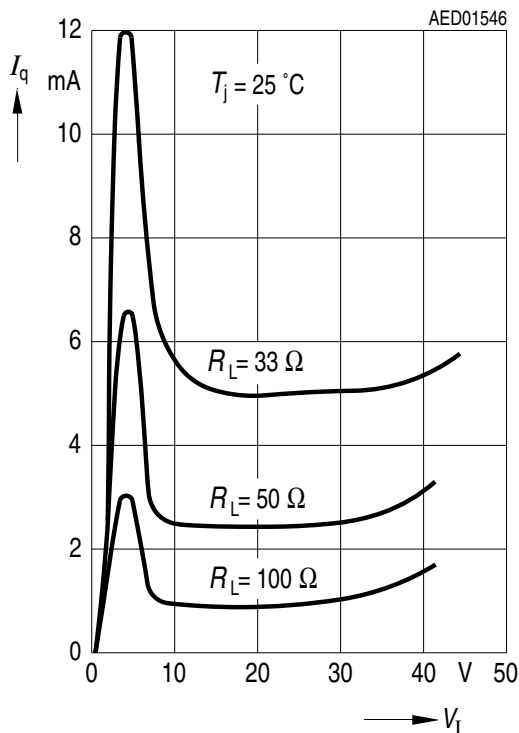

**Output voltage  $V_Q$  versus input voltage  $V_i$**

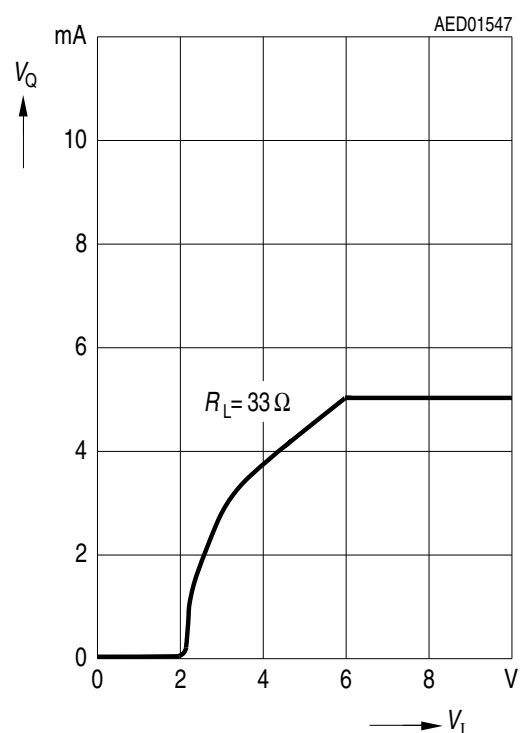

**Functional description**

**Charge current  $I_{D,wc}$  and discharge current  $I_{D,wd}$  versus temperature  $T_j$**

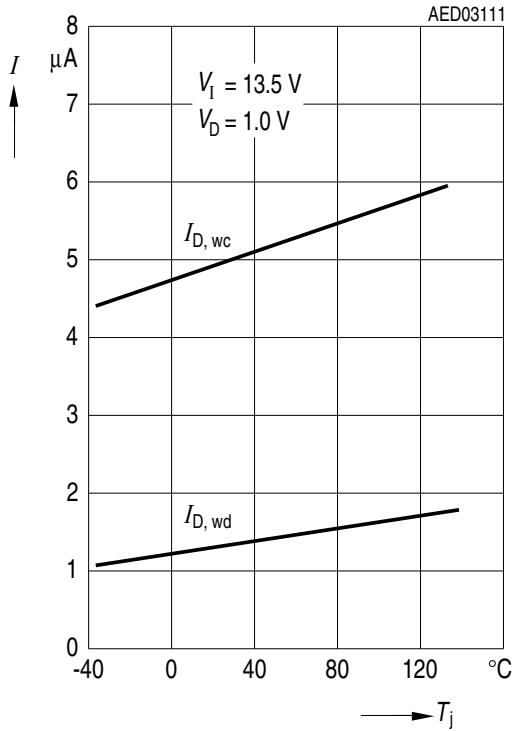

**Switching voltage  $V_{DU}$ ,  $V_{DWL}$  and  $V_{DRL}$  versus temperature  $T_j$**

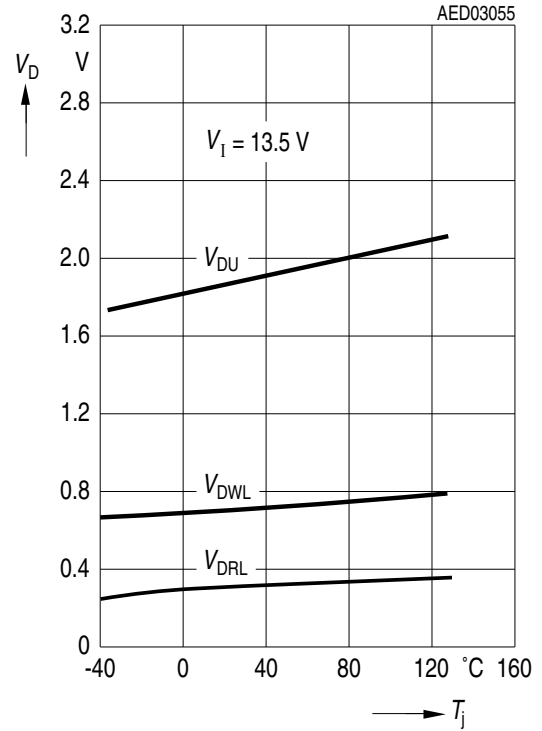

**Output voltage  $V_Q$  versus temperature  $T_j$**

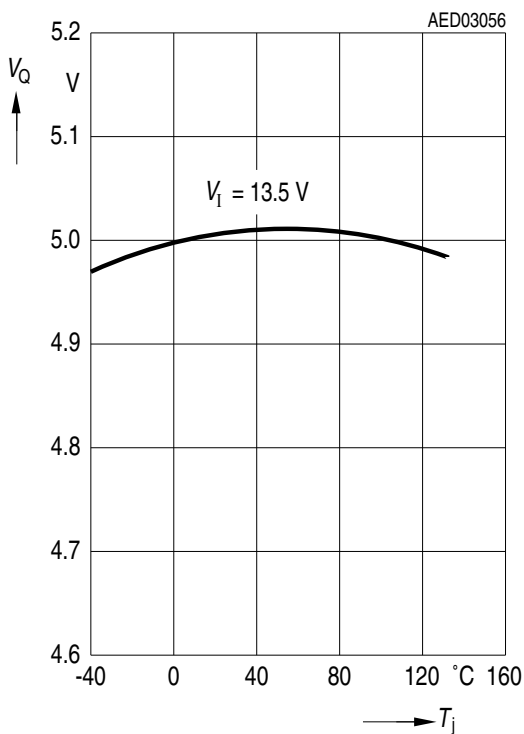

**Output current limit  $I_Q$  versus input voltage  $V_I$**

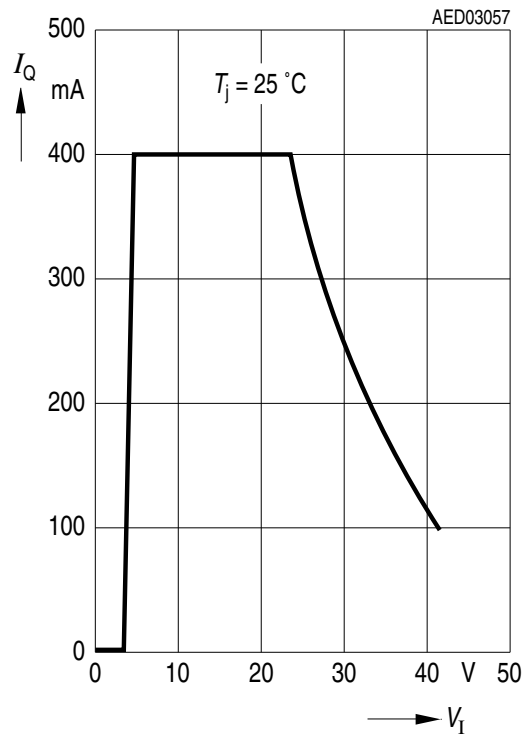

## 5 Application information

### 5.1 Input, output

The input capacitors  $C_{I1}$  and  $C_{I2}$  are necessary for compensating line influences. Using a resistor of approx.  $1\ \Omega$  in series with  $C_{I1}$ , the LC circuit of input inductance and input capacitance can be damped. To stabilize the regulation circuit the output capacitor  $C_Q$  is necessary. Stability is ensured at values  $C_Q \geq 10\ \mu\text{F}$  with an  $\text{ESR} \leq 5\ \Omega$  within the operating temperature range.

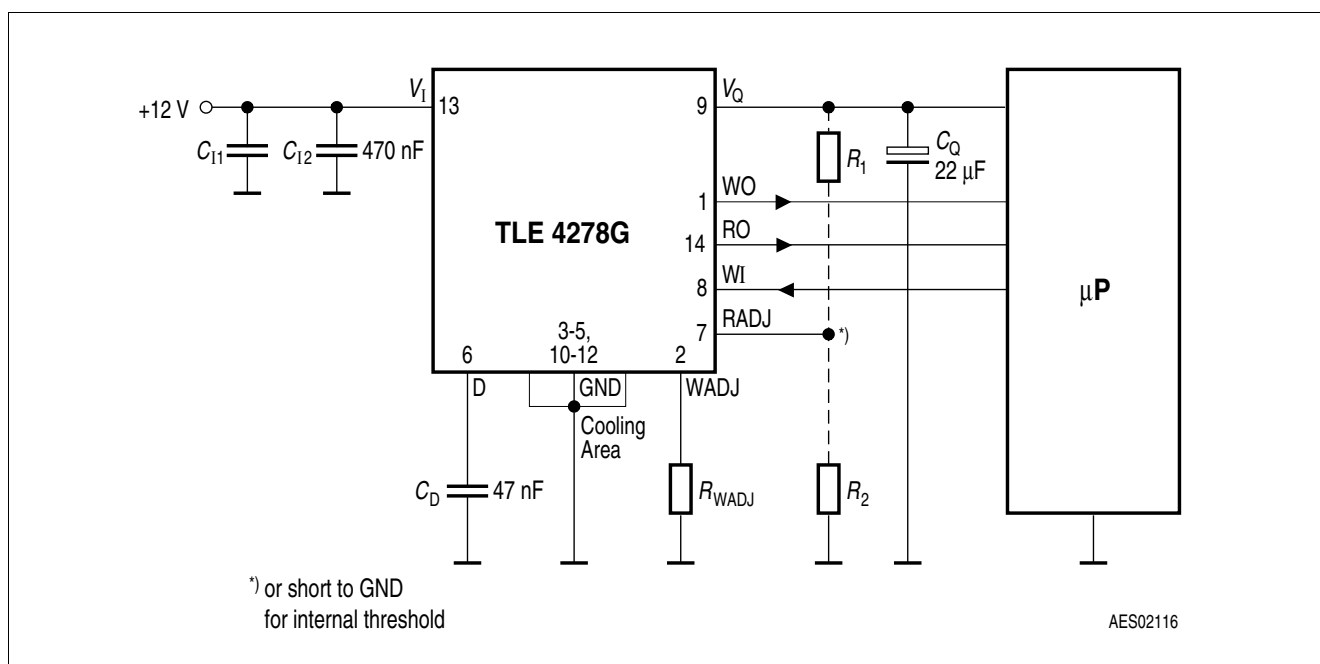

**Figure 4 Application circuit**

**Application information**

**5.2 Reset timing**

The power-on reset delay time is defined by the charging time of an external capacitor  $C_D$  which can be calculated as follows:

$$C_D = (\Delta t_{rd} \times I_{D,c}) / \Delta V \tag{5.1}$$

Definitions:

- $C_D$  = delay capacitor
- $\Delta t_{rd}$  = delay time
- $I_{D,c}$  = charge current, typical 5  $\mu$ A
- $\Delta V = V_{DU}$ , typical 1.9 V
- $V_{DU}$  = upper delay switching threshold at  $C_D$  for reset delay time

The reset reaction time  $t_{rr}$  is the time it takes the voltage regulator to set the reset out “low” after the output voltage has dropped below the reset threshold. It is typically 1  $\mu$ s for delay capacitor of 47 nF. For other values for  $C_D$  the reaction time can be estimated using **Equation (5.2)**:

$$t_{rr} \approx 20 \text{ s/F} \times C_D \tag{5.2}$$

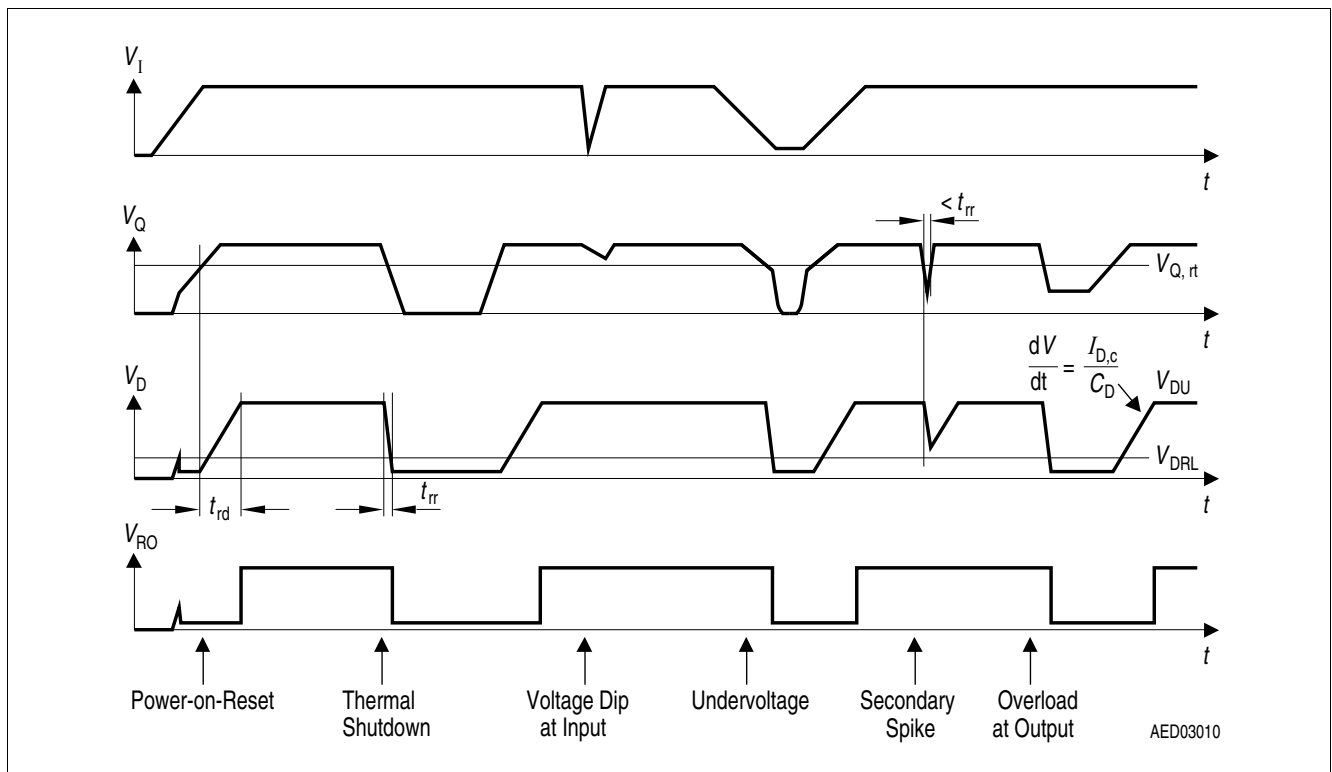

**Figure 5 Reset timing (watchdog disabled)**

**Application information**

**5.3 Reset switching threshold**

The present default value is 4.65 V. When using the TLE4278 the reset threshold can be set to  $3.5\text{ V} < V_{Q,rt} < 4.6\text{ V}$  by connecting an external voltage divider to pin RADJ. The calculation can be easily done since the reset adjust input current can be neglected. If this feature is not needed, the pin must be connected to GND.

$$V_{Q,rt} = V_{ref} \times (1 + R_1/R_2) \tag{5.3}$$

Definitions:

- $V_{Q,rt}$  = Reset threshold
- $V_{ref}$  = comparator reference voltage, typical 1.35 V  
 (Reset adjust input current  $\approx 50\text{ nA}$ )

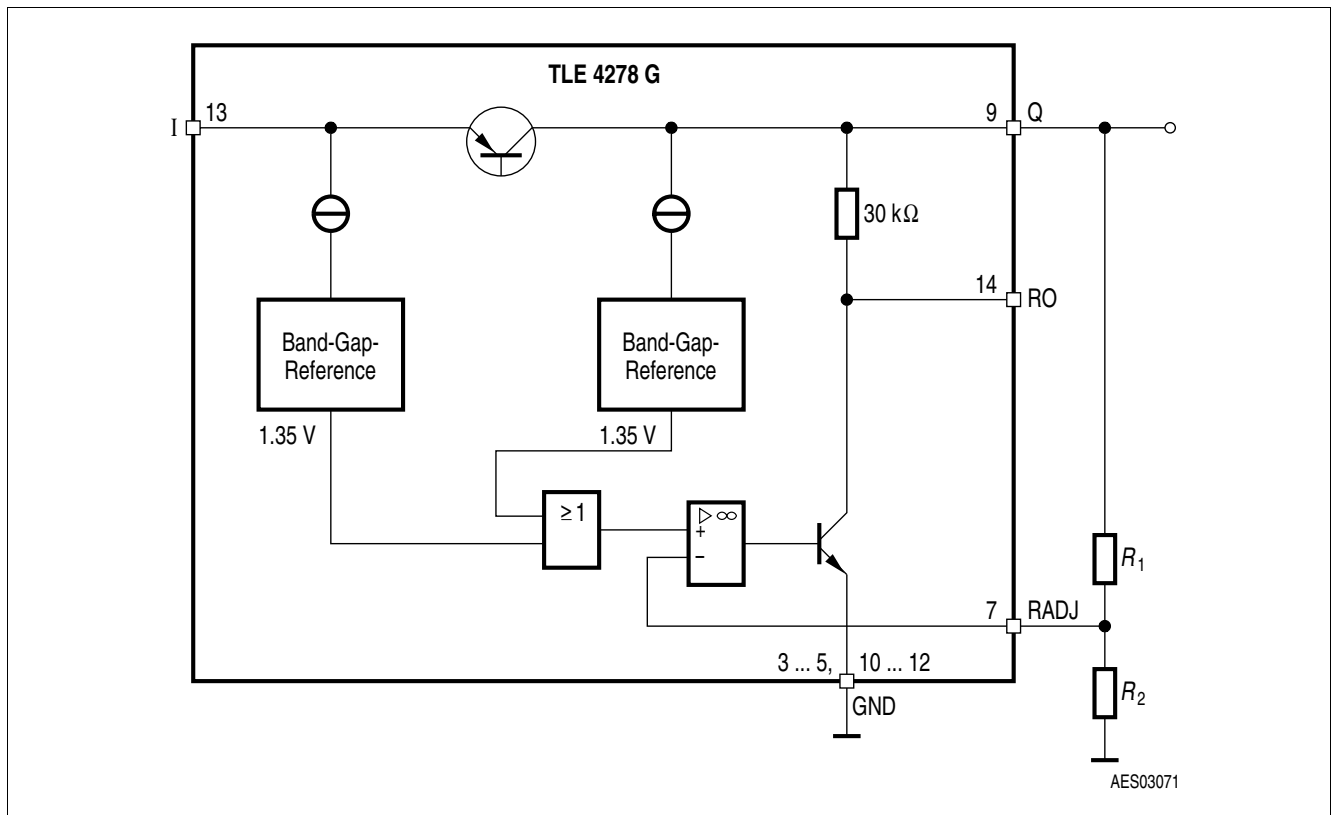

**Figure 6 Reset switching threshold**

The reset output pin is internally connected to the 5 V output Q via a 30 kΩ pull-up resistor. Down to an output voltage  $V_Q$  of typical 1 V the reset “low” signal at pin RO is generated.

For the timing of the reset feature please refer to [Figure 5](#).

**Application information**

**5.4 Watchdog activating**

The calculation of the external resistor which adjusts the watchdog switch off threshold can be done by **Equation (5.4)**:

$$R_{WADJ} = V_{WADJ,th} \times (I_Q/I_{WADJ})/I_{Q,act} \tag{5.4}$$

Definitions:

- $V_{WADJ,th}$  = switch off threshold, typical 1.35 V
- $I_Q/I_{WADJ}$  = current ratio, typical 720
- $I_{Q,act}$  = switch off load current

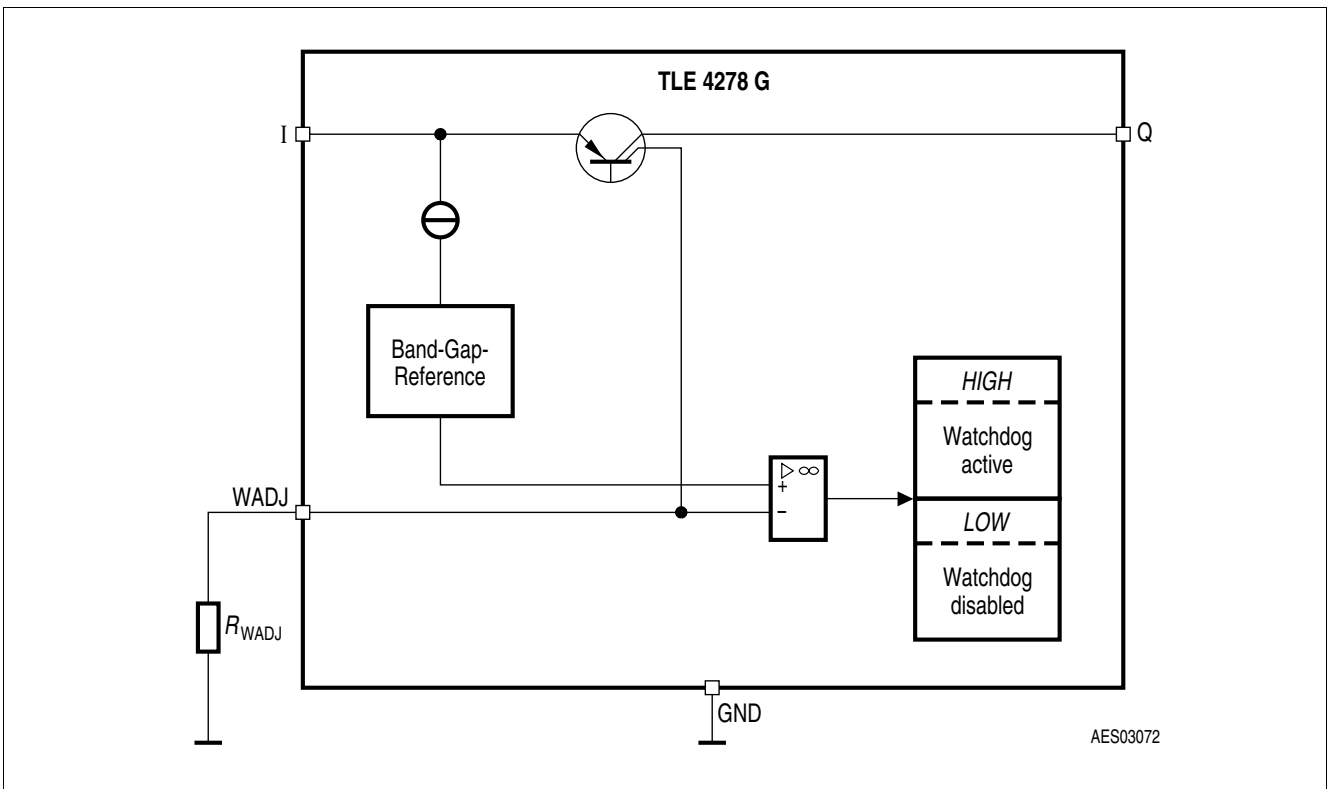

**Figure 7 Watchdog activating**



**Application information**

**5.5 Watchdog timing**

The frequency of the watchdog pulses must be higher than the minimum pulse sequence which is set by the external reset delay capacitor  $C_D$ . Calculation can be done according to the formulas given in **Figure 8**.

The watchdog output is internally connected to the output Q via a 30 kΩ pull-up resistor. To generate a watchdog created reset signal for the microcontroller the pin WO can be connected to the reset input of the microcontroller. It is also allowed to parallel the watchdog out to the reset out.

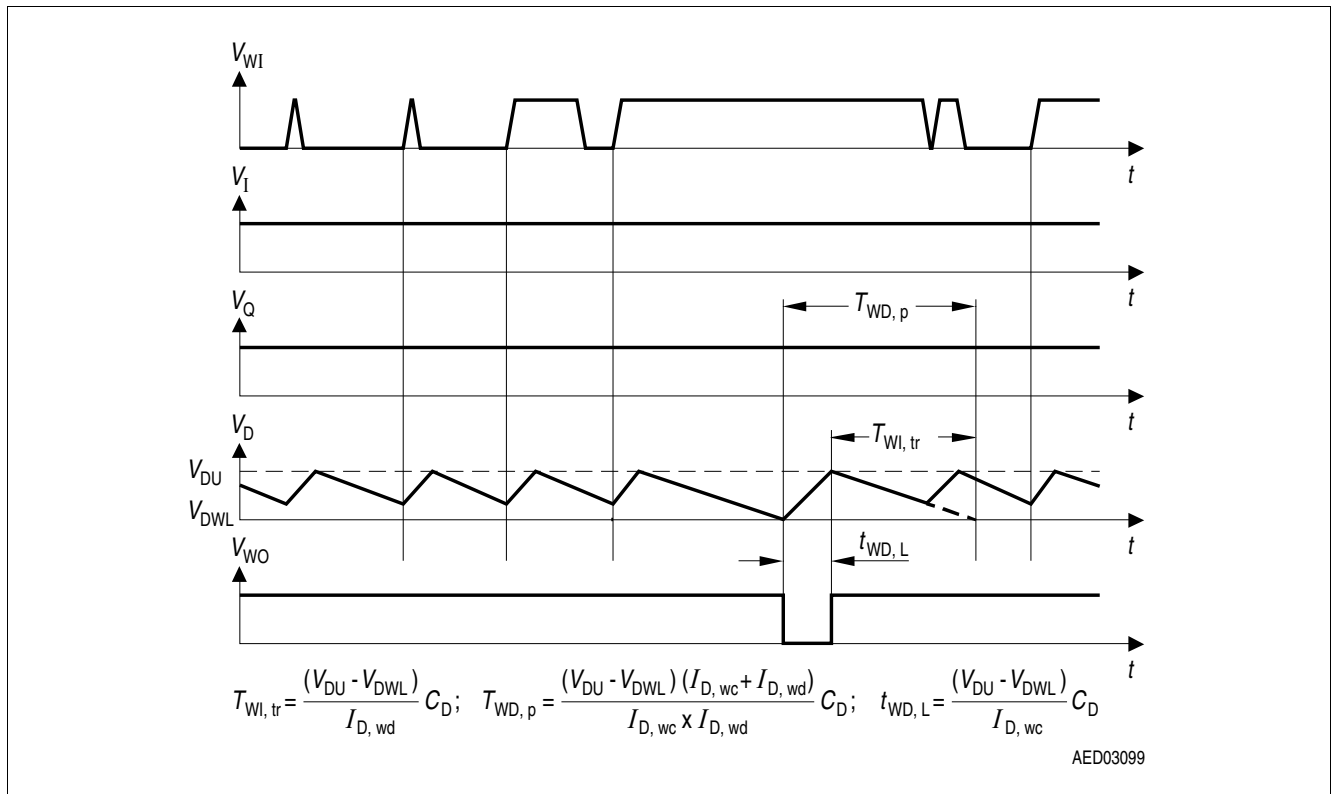

**Figure 8 Timing of the watchdog function**

**Application information**

**5.6 Hints for unused pins**

**Table 6 Hints for unused pins**

<b>Symbol</b>	<b>Function</b>	<b>Connect to</b>
RO	Reset output	Open
D	Reset delay	Open or to output Q
RADJ	Reset switching threshold adjust	GND
WI	Watchdog input	GND
WO	Watchdog output	Open
WADJ	Watchdog adjust	<sup>1)</sup> To output Q via a 270 kΩ resistor: Watchdog always active <sup>2)</sup> To GND: Watchdog disabled

## 6 Package information

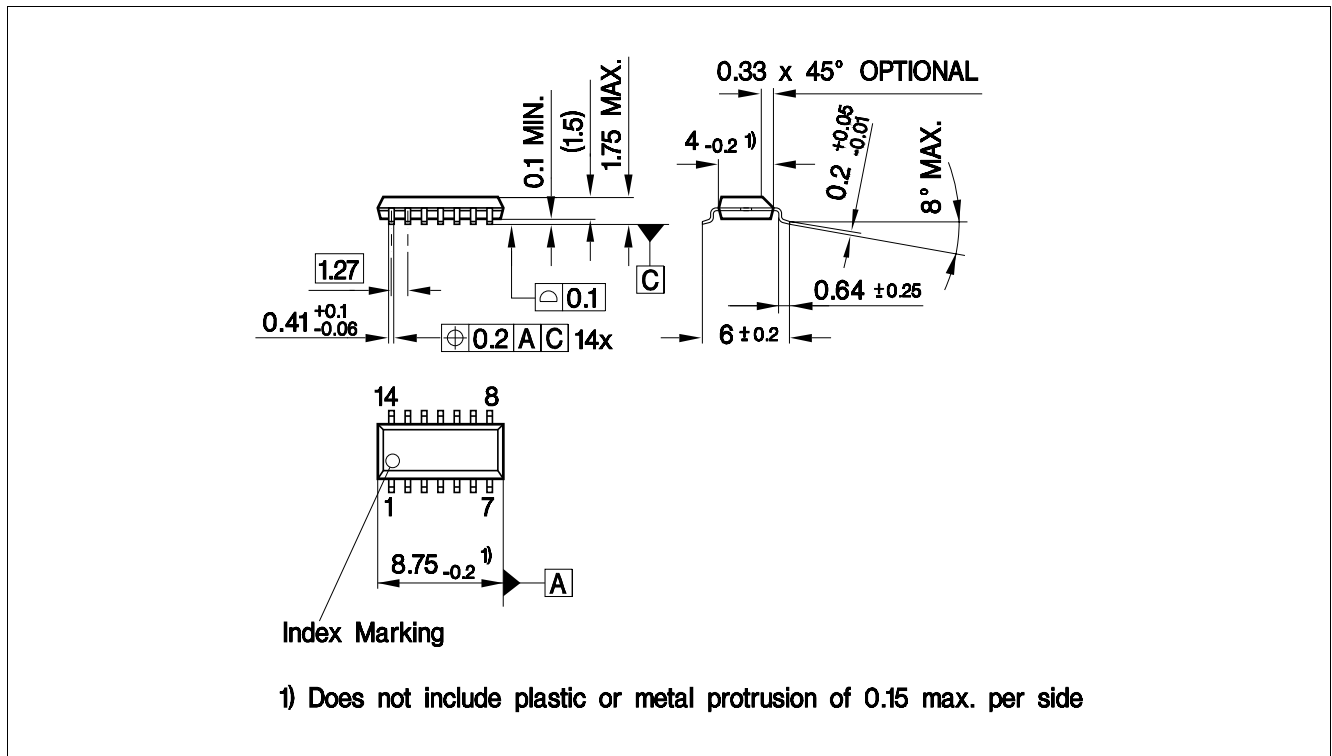

**Figure 9 PG-DSO-14 (Plastic Dual Small Outline) <sup>1)</sup>**

### Green Product (RoHS compliant)

To meet the world-wide customer requirements for environmentally friendly products and to be compliant with government regulations the device is available as a green product. Green products are RoHS-Compliant (i.e Pb-free finish on leads and suitable for Pb-free soldering according to IPC/JEDEC J-STD-020).

### Further information on packages

<https://www.infineon.com/packages>

1) Dimension in mm

**Revision history**

## **7 Revision history**

<b>Revision</b>	<b>Date</b>	<b>Changes</b>
1.5	2018-09-10	Updated layout and structure Updated packaged drawing “PG-DSO-14” Editorial changes

## Trademarks

All referenced product or service names and trademarks are the property of their respective owners.

**Edition 2018-09-10**

**Published by**

**Infineon Technologies AG**

**81726 Munich, Germany**

**© 2018 Infineon Technologies AG.**

**All Rights Reserved.**

**Do you have a question about any aspect of this document?**

**Email: [erratum@infineon.com](mailto:erratum@infineon.com)**

**Document reference**

**Z8F55294583**

## IMPORTANT NOTICE

The information given in this document shall in no event be regarded as a guarantee of conditions or characteristics ("Beschaffheitsgarantie").

With respect to any examples, hints or any typical values stated herein and/or any information regarding the application of the product, Infineon Technologies hereby disclaims any and all warranties and liabilities of any kind, including without limitation warranties of non-infringement of intellectual property rights of any third party.

In addition, any information given in this document is subject to customer's compliance with its obligations stated in this document and any applicable legal requirements, norms and standards concerning customer's products and any use of the product of Infineon Technologies in customer's applications.

The data contained in this document is exclusively intended for technically trained staff. It is the responsibility of customer's technical departments to evaluate the suitability of the product for the intended application and the completeness of the product information given in this document with respect to such application.

For further information on technology, delivery terms and conditions and prices, please contact the nearest Infineon Technologies Office ([www.infineon.com](http://www.infineon.com)).

## WARNINGS

Due to technical requirements products may contain dangerous substances. For information on the types in question please contact your nearest Infineon Technologies office.

Except as otherwise explicitly approved by Infineon Technologies in a written document signed by authorized representatives of Infineon Technologies, Infineon Technologies' products may not be used in any applications where a failure of the product or any consequences of the use thereof can reasonably be expected to result in personal injury.

## X-ON Electronics

Largest Supplier of Electrical and Electronic Components

*Click to view similar products for [LDO Voltage Regulators](#) category:*

*Click to view products by [Infineon](#) manufacturer:*

Other Similar products are found below :

[M38D29FFHP#U1](#) [702103A](#) [717726C](#) [742457H](#) [MP20051DN-LF-Z](#) [R5F111PGGFB#30](#) [AP7363-SP-13](#) [NCP103AMX285TCG](#)  
[NCV8664CST33T3G](#) [NCV8752AMX28TCG](#) [L9454](#) [AP7362-HA-7](#) [LX13043CLD](#) [TCR3DF185,LM\(CT](#) [TCR3DF24,LM\(CT](#)  
[TCR3DF285,LM\(CT](#) [TCR3DF31,LM\(CT](#) [TCR3DF45,LM\(CT](#) [TLF4949EJ](#) [MP2013GQ-33-Z](#) [L9708](#) [L970813TR](#) [030014BB](#) [059985X](#)  
[NCP121AMX173TCG](#) [NCP4687DH15T1G](#) [701326R](#) [702087BB](#) [755078E](#) [TCR2EN28,LF\(S](#) [LM1117DT-1.8/NO](#) [LT1086CM#TRPBF](#)  
[AZ1085S2-1.5TRE1](#) [MAX15101EWL+T](#) [NCV8170AXV250T2G](#) [TCR3DF27,LM\(CT](#) [TCR3DF19,LM\(CT](#) [TCR3DF125,LM\(CT](#)  
[TCR2EN18,LF\(S](#) [MAX15103EWL+T](#) [TS2937CZ-5.0 C0](#) [MAX8878EUK30-T](#) [MAX663CPA](#) [NCV4269CPD50R2G](#) [NCV8716MT30TBG](#)  
[AZ1117IH-1.2TRG1](#) [MP2013GQ-P](#) [AP2112R5A-3.3TRG1](#) [AP7315-25W5-7](#) [MAX15102EWL+T](#)