

OPTIREG™ Linear TLE4279

5V low drop fixed voltage regulator



Features

- Output voltage tolerance $\leq \pm 2\%$
- 150 mA current capability
- Very low current consumption
- Early warning
- Reset output low down to $V_Q = 1\text{ V}$
- Overtemperature protection
- Reverse polarity proof
- Adjustable reset threshold
- Very low-drop voltage
- Wide temperature range
- Green Product (RoHS compliant)

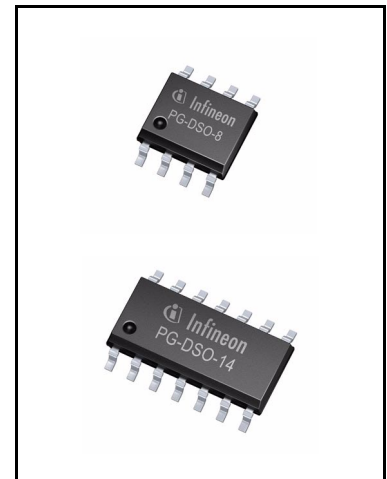

Potential applications

General automotive applications.

Product validation

Qualified for Automotive Applications. Product Validation according to AEC-Q100/101

Description

The OPTIREG™ Linear TLE4279 is an automotive voltage regulator with a 5 V fixed output, in a PG-DSO-8 or PG-DSO-14 package. The maximum operating voltage is 45 V. The output is able to drive 150 mA load. The device features short-circuit protection. The thermal shutdown feature switches the output off when the junction temperature exceeds 150°C to ensure the device is not damaged by overheating. A reset signal is generated when the output voltage drops below $V_Q < 4.65\text{ V}$. The reset threshold voltage can be decreased by an external connection of a voltage divider. The reset delay time can be set by an external capacitor. If the application requires pull-up resistors at the logic outputs (Reset, Sense Out) the TLE4269 with integrated resistors can be used. It is also possible to supervise the input voltage by using an integrated comparator to give a low voltage warning.

Type	Package	Marking
TLE4279G	PG-DSO-8	TLE4279
TLE4279GM	PG-DSO-14	TLE 4279

Table of Contents

1	Block diagram	3
2	Pin configuration	4
3	General product characteristics	6
3.1	Absolute maximum ratings	6
3.2	Electrical characteristics	8
4	Functional description	9
5	Application description	10
5.1	Typical performance characteristics	12
6	Package information	15
7	Revision History	16

Block diagram

1 Block diagram

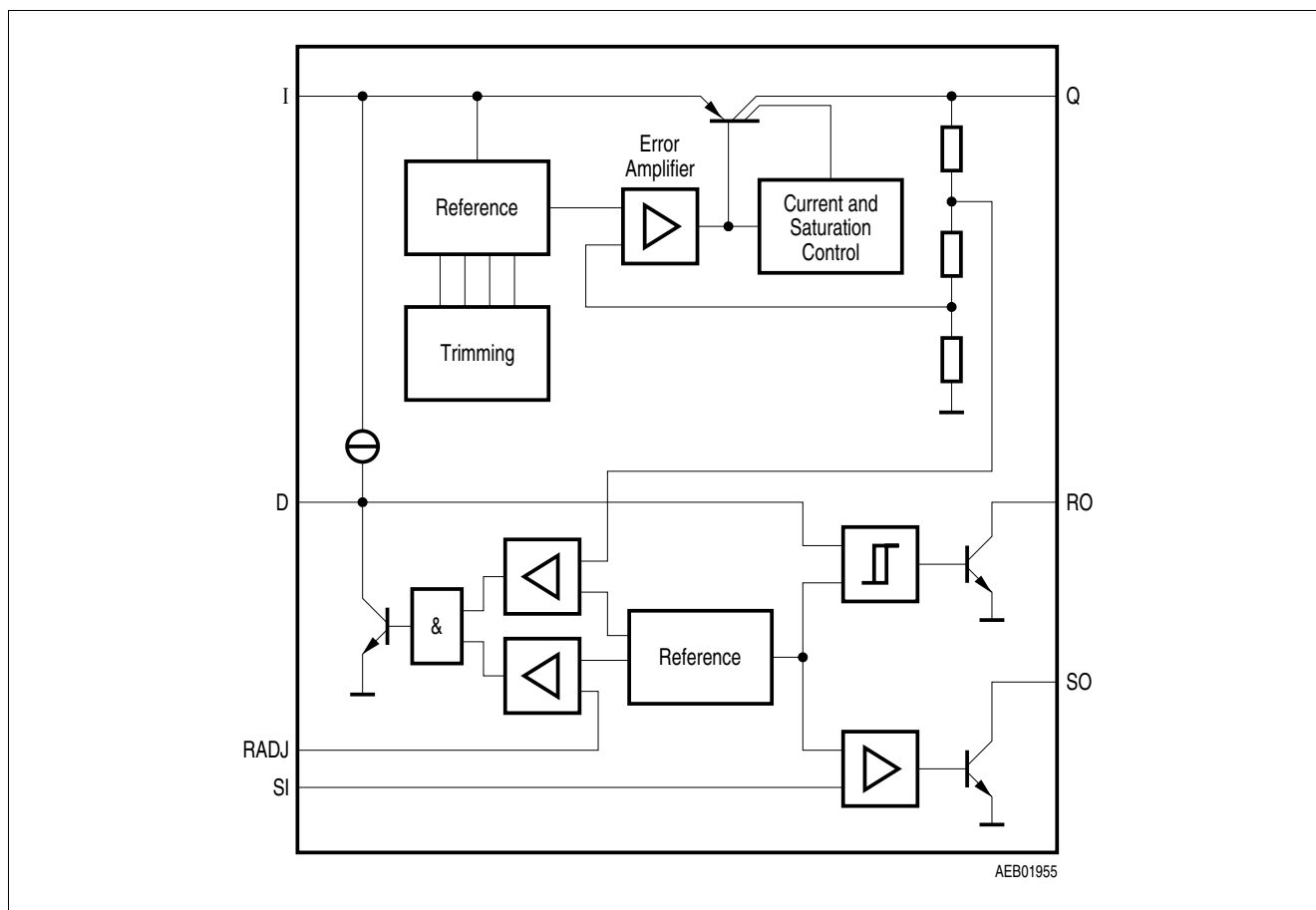

Figure 1 Block diagram

Pin configuration

2 Pin configuration

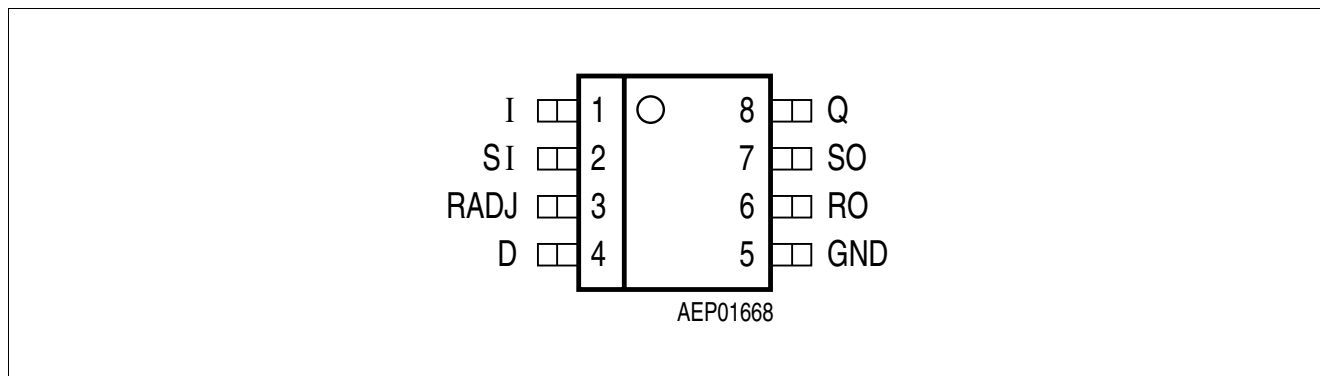

Figure 2 Pin configuration PG-DSO-8 (top view)

Table 1 Pin definitions and functions (TLE4279G)

Pin No.	Symbol	Function
1	I	Input ; block to GND directly at the IC with a ceramic capacitor
2	SI	Sense input ; if not needed connect to Q
3	RADJ	Reset threshold adjust ; if not needed connect to ground
4	D	Reset delay ; to select the delay time, connect to GND via external capacitor
5	GND	Ground
6	RO	Reset output ; open-collector output. Keep open, if not needed
7	SO	Sense output ; open-collector output. Keep open, if not needed
8	Q	5-V output ; connect to GND with a 10 μF capacitor, ESR < 10 Ω

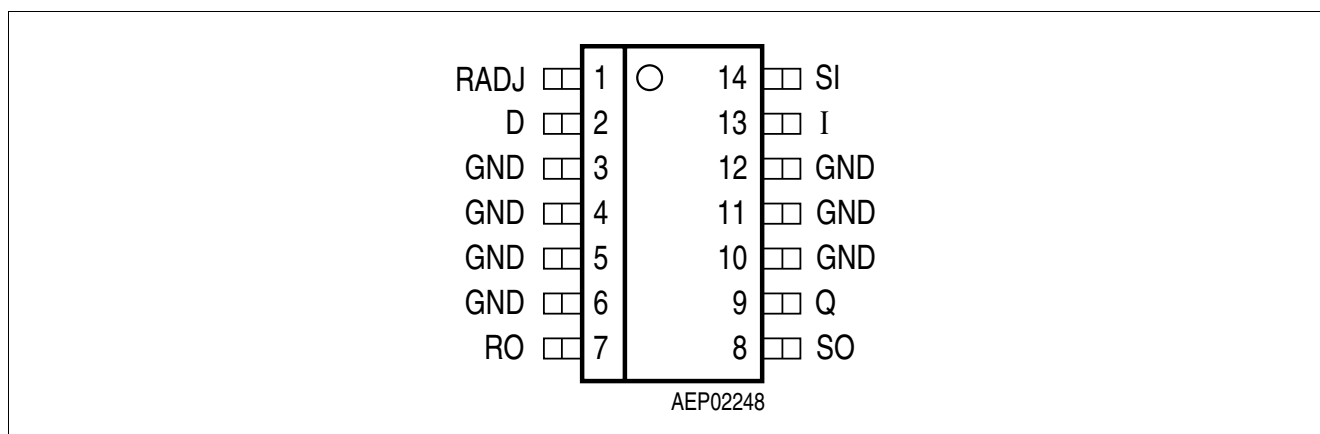

Figure 3 Pin configuration PG-DSO-14 (top view)

Table 2 Pin definitions and functions (TLE4279GM)

Pin No.	Symbol	Function
1	RADJ	Reset threshold adjust ; if not needed connect to GND
2	D	Reset delay ; connect to GND via external delay capacitor for setting delay time
3, 4, 5, 6	GND	Ground

Pin configuration

Table 2 Pin definitions and functions (TLE4279GM) (cont'd)

Pin No.	Symbol	Function
7	RO	Reset output; open-collector output. Keep open, if not needed
8	SO	Sense output; open-collector output. Keep open, if not needed
9	Q	5-V output; connect to GND via 10 μ F capacitor, ESR < 10 Ω
10, 11, 12	GND	Ground
13	I	Input; block to GND directly at the IC by a ceramic capacitor
14	SI	Sense input; if not needed connect to Q

General product characteristics

3 General product characteristics

3.1 Absolute maximum ratings

Table 3 Absolute maximum ratings

$T_j = -40$ to 150 °C

Parameter	Symbol	Values			Unit	Note or Test Condition
		Min.	Typ.	Max.		
Input						
Input voltage	V_I	-40	-	45	V	-
Input current	I_I	-	-	-	-	internal limited
Sense input						
Input voltage	V_{SI}	-40	-	45	V	-
Input current	I_{SI}	1	-	1	mA	-
Reset threshold						
Voltage	V_{RADJ}	-40	-	7	V	-
Current	I_{RADJ}	-10	-	10	mA	-
Reset delay						
Voltage	V_D	-0.3	-	7	V	-
Current	I_D	-	-	-	-	internal limited
Ground						
Current	I_{GND}	50	-	-	mA	-
Reset output						
Voltage	V_R	-0.3	-	7	V	-
Current	I_R	-	-	-	-	internal limited
Sense output						
Voltage	V_{SO}	-0.3	-	7	V	-
Current	I_{SO}	-	-	-	-	internal limited
5-V Output						
Output voltage	V_Q	-0.5	-	7	V	-
Output current	I_Q	-10	-	-	mA	-
Temperature						
Junction temperature	T_j	-	-	150	°C	-
Storage temperature	T_{Stg}	-50	-	150	°C	-

General product characteristics

Table 3 Absolute maximum ratings (cont'd)

$T_j = -40$ to 150 °C

Parameter	Symbol	Values			Unit	Note or Test Condition
		Min.	Typ.	Max.		
Operating range						
Input voltage	V_I	–	–	45	V	–
Junction temperature	T_j	-40	–	150	°C	–
Thermal data						
Junction-ambient	R_{thja}	–	–	200	K/W	PG-DSO-8
		–	–	70	K/W	PG-DSO-14
Junction-pin	R_{thjp}	–	–	30	K/W	PG-DSO-14 ¹⁾

1) measured to Pin 4

General product characteristics

3.2 Electrical characteristics

Table 4 Electrical characteristics

$V_I = 13.5\text{ V}; -40\text{ °C} \leq T_j \leq 125\text{ °C}$

Parameter	Symbol	Values			Unit	Note or Test Condition
		Min.	Typ.	Max.		
Output voltage	V_Q	4.90	5.00	5.10	V	$1\text{ mA} \leq I_Q \leq 100\text{ mA}$ $6\text{ V} \leq V_I \leq 16\text{ V}$
Current limit	I_Q	150	200	500	mA	–
Current consumption; $I_q = I_I - I_Q$	I_q	–	150	300	μA	$I_Q \leq 1\text{ mA}, T_j < 85\text{ °C}$
Current consumption; $I_q = I_I - I_Q$	I_q	–	250	700	μA	$I_Q = 10\text{ mA}$
Current consumption; $I_q = I_I - I_Q$	I_q	–	2	8	mA	$I_Q = 50\text{ mA}$
Drop voltage	V_{dr}	–	0.25	0.5	V	$I_Q = 100\text{ mA}^{1)}$
Load regulation	ΔV_Q	–	10	30	mV	$I_Q = 5\text{ mA to } 100\text{ mA}$
Line regulation	ΔV_Q	–	10	40	mV	$V_I = 6\text{ V to } 26\text{ V}$ $I_Q = 1\text{ mA}$

Reset generator

Switching threshold	V_{RT}	4.50	4.65	4.80	V	–
Reset adjust switching voltage	$V_{RADJ,TH}$	1.26	1.35	1.44	V	$V_Q > 3.5\text{ V}$
Reset low voltage	$V_{RO,SAT}$	–	0.1	0.4	V	$R_{\text{extern}} = 20\text{ k}\Omega$
Upper delay switching threshold	V_{UD}	1.4	1.8	2.2	V	–
Lower delay switching threshold	V_{LD}	0.3	0.45	0.60	V	–
Reset delay low voltage	$V_{D,SAT}$	–	–	0.1	V	$V_Q < V_{RT}$
Charge current	I_D	3.0	6.5	9.5	μA	$V_D = 1\text{ V}$
Delay time L → H	t_d	17	28	–	ms	$C_D = 100\text{ nF}$
Delay time H → L	t_t	–	1	–	μs	$C_D = 100\text{ nF}$

Input voltage sense

Sense threshold high	$V_{SI,high}$	1.24	1.31	1.38	V	–
Sense threshold low	$V_{SI,low}$	1.16	1.20	1.28	V	–
Sense output low voltage	$V_{SO,low}$	–	0.1	0.4	V	$V_{SI} < 1.20\text{ V};$ $V_Q > 3\text{ V};$ $R_{\text{extern}} = 20\text{ k}\Omega$
Sense input current	I_{SI}	-1	0.1	1	μA	–

1) Drop voltage = $V_I - V_Q$ (measured when the output voltage has dropped 100 mV from the nominal value obtained at 13.5 V input.)

Functional description

4 Functional description

The control amplifier compares a reference voltage, made highly accurate by resistance balancing, with a voltage proportional to the output voltage and drives the base of the series PNP transistor via a buffer. Saturation control as a function of the load current prevents any over-saturation of the power element.

The reset output RO is in high-state if the voltage on the delay capacitor C_D is greater or equal V_{UD} . The delay capacitor C_D is charged with the current I_D for output voltages greater than the reset threshold V_{RT} . If the output voltage gets lower than V_{RT} ('reset condition') a fast discharge of the delay capacitor C_D sets in and as soon as V_D gets lower than V_{LD} the reset output RO is set to low-level.

The time gap for the delay capacitor discharge is the reset reaction time t_{RR} .

The reset threshold V_{RT} can be decreased via an external voltage divider connected to the pin RADJ. In this case the reset condition is reached if $V_Q < V_{RT}$ and $V_{RADJ} < V_{RAQDJ,TH}$. Dimensioning the voltage divider (see **Figure 4**) according to:

(4.1)

$$V_{THRES} = \frac{V_{RAD(J, TH)} \times (R_{ADJ1} + R_{ADJ2})}{R_{ADJ2}}$$

the reset threshold can be decreased down to 3.5 V. If the reset-adjust-option is not needed the RADJ-pin should be connected to GND causing the reset threshold to go to its default value (typ. 4.65 V).

A built in comparator compares the signal of the pin SI, normally fed by a voltage divider from the input voltage, with the reference and gives an early warning on the pin SO. It is also possible to superwise another voltage e.g. of a second regulator, or to build a watchdog circuit with few external components.

Application information

5 Application information

The input capacitor C_1 is necessary for compensating line influences. Using a resistor of approx. $1\ \Omega$ in series with C_1 , the oscillating circuit consisting of input inductivity and input capacitance can be damped. The output capacitor C_Q is necessary for the stability of the regulating circuit. Stability is guaranteed at values $\geq 10\ \mu\text{F}$ and an $\text{ESR} \leq 10\ \Omega$ within the operating temperature range. Both reset output and sense output are open collector outputs and have to be connected to 5 V output via external pull-up resistors $\geq 10\ \text{k}\Omega$. For small tolerances of the reset delay the spread of the capacitance of the delay capacitor and its temperature coefficient should be noted.

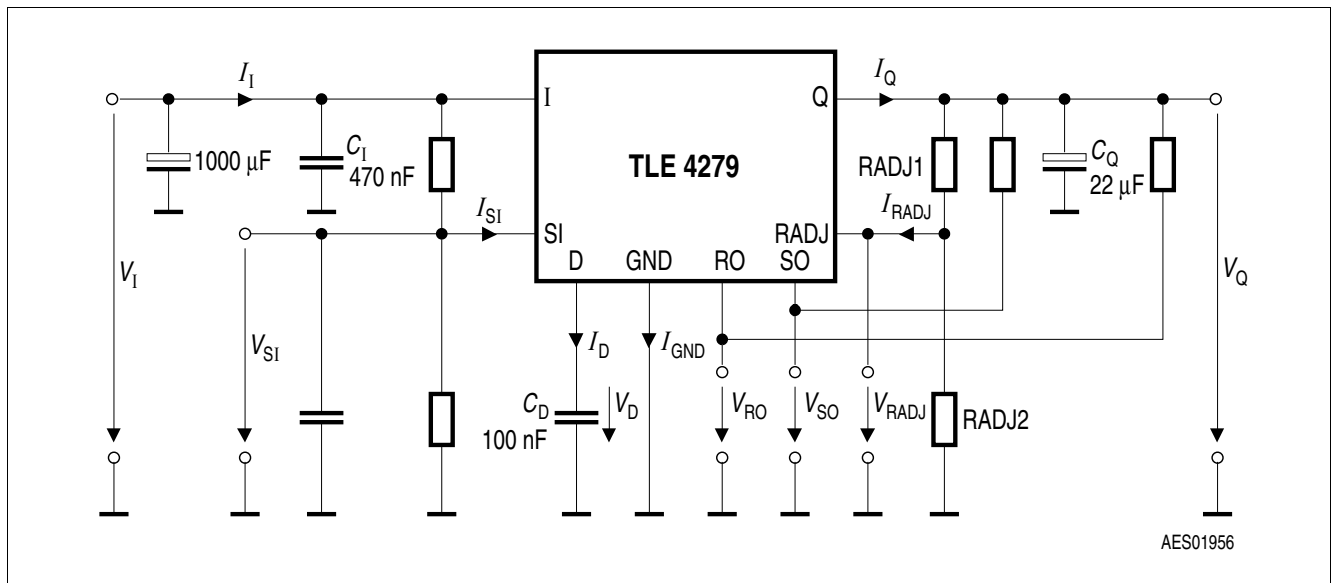

Figure 4 Measuring circuit

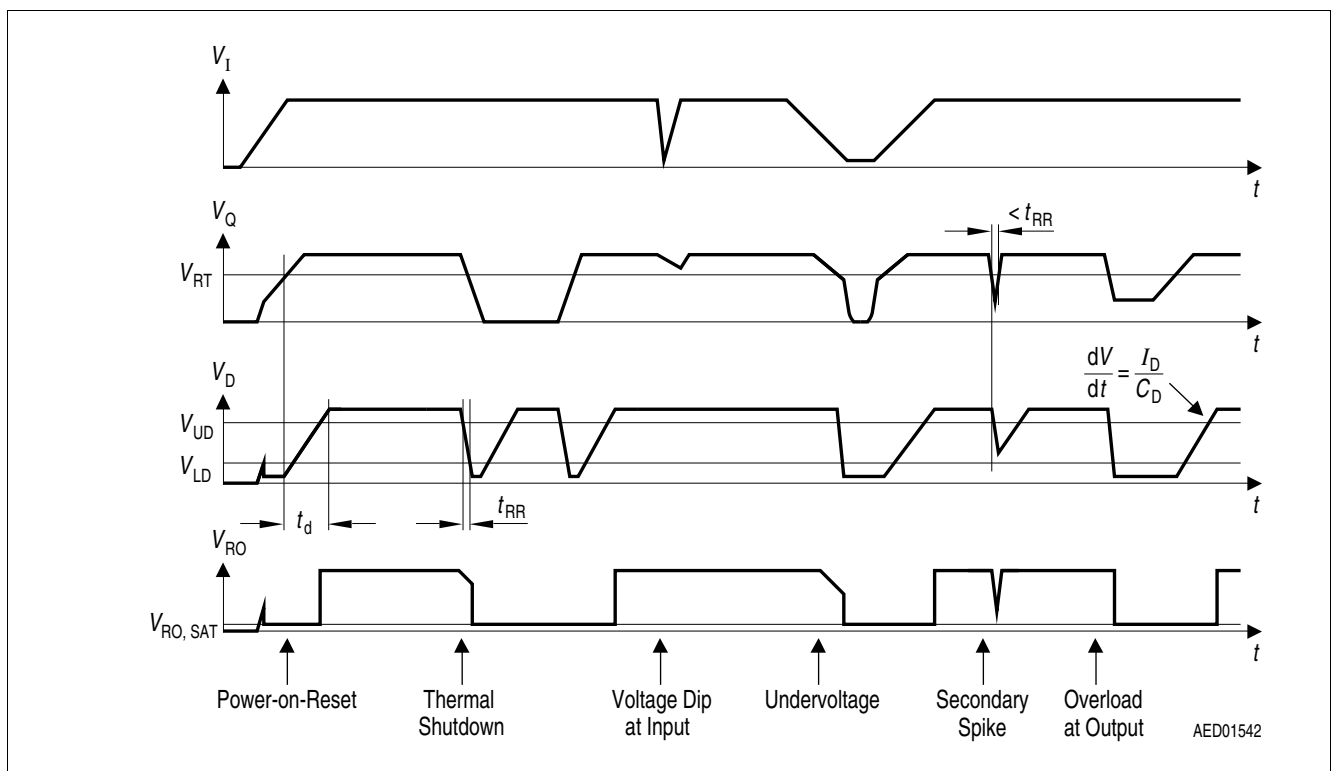

Figure 5 Reset timing diagram

Application information

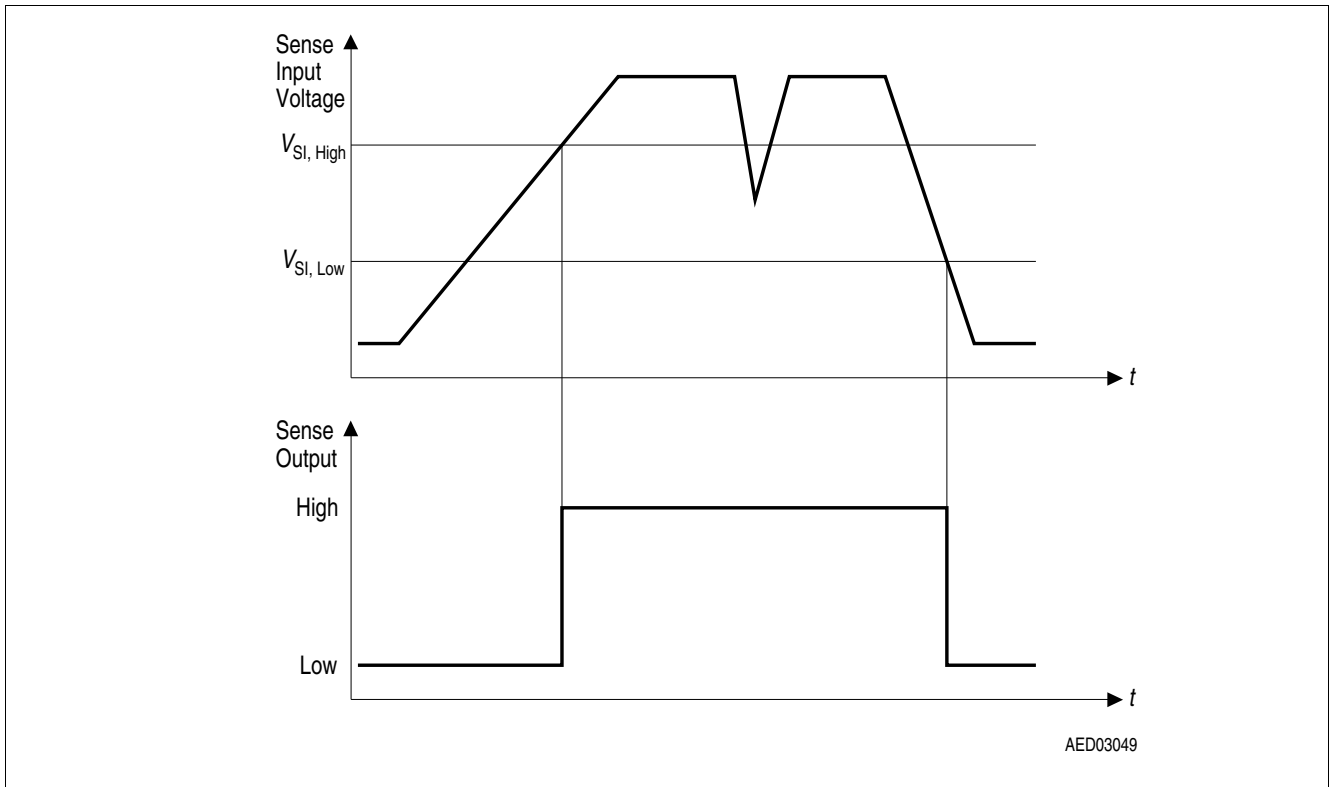
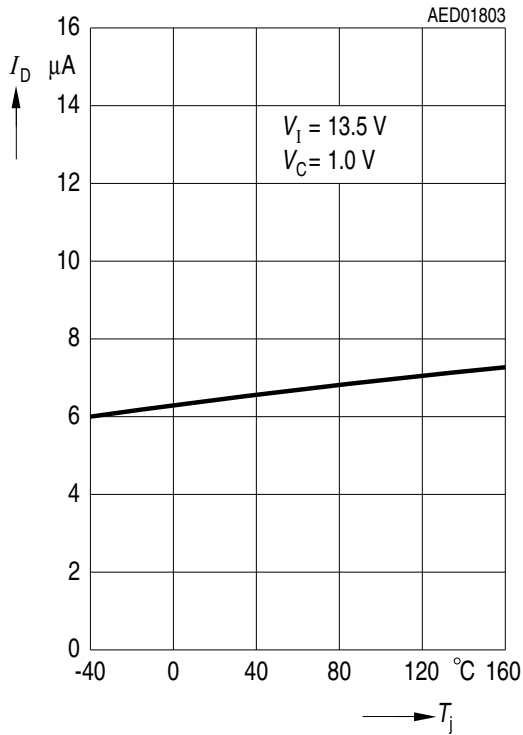

Figure 6 Sense input timing diagram

Application information

5.1 Typical performance characteristics

Charge current I_D versus temperature T_j



Drop voltage V_{dr} versus output current I_Q

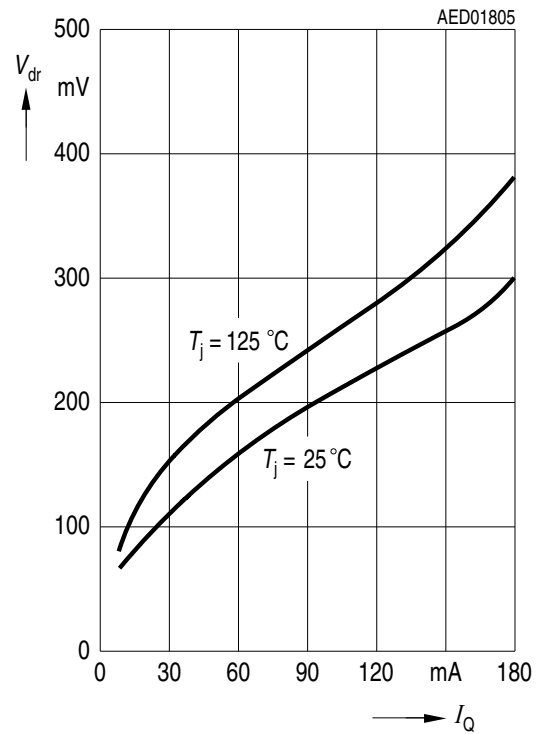

Switching voltage V_{UD} and V_{LD} versus temperature T_j

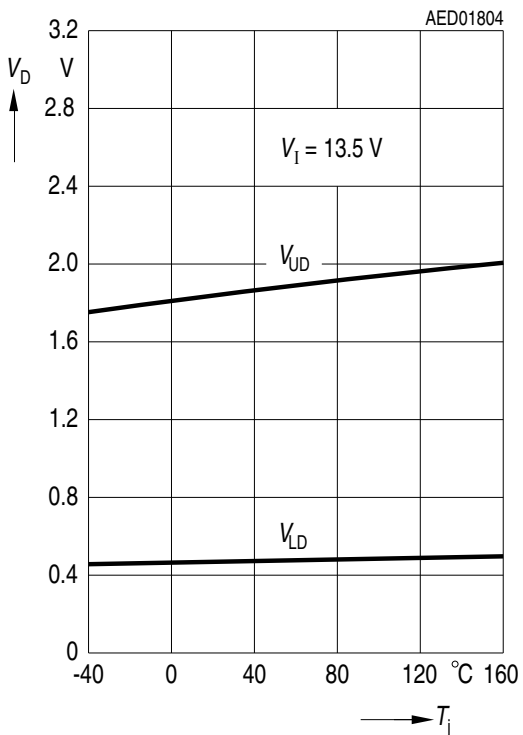

Reset adjust switching threshold $V_{RADJ,TH}$ versus temperature T_j

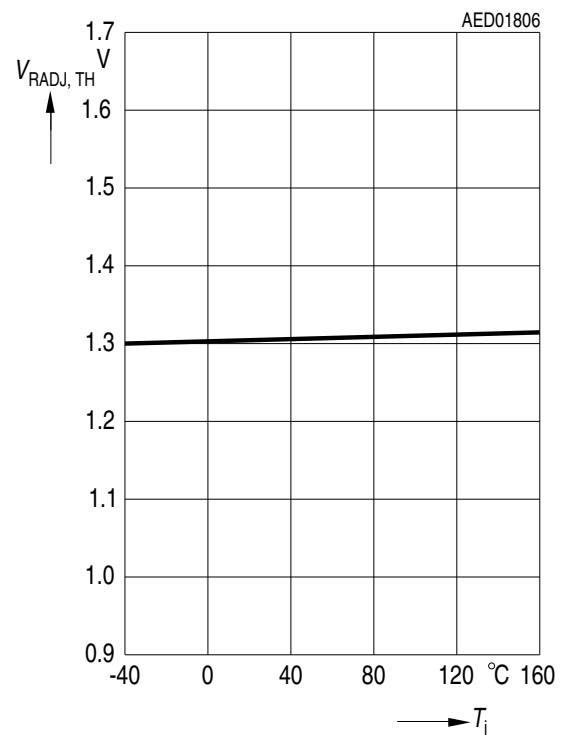

Application information

Current consumption I_Q versus input voltage V_I

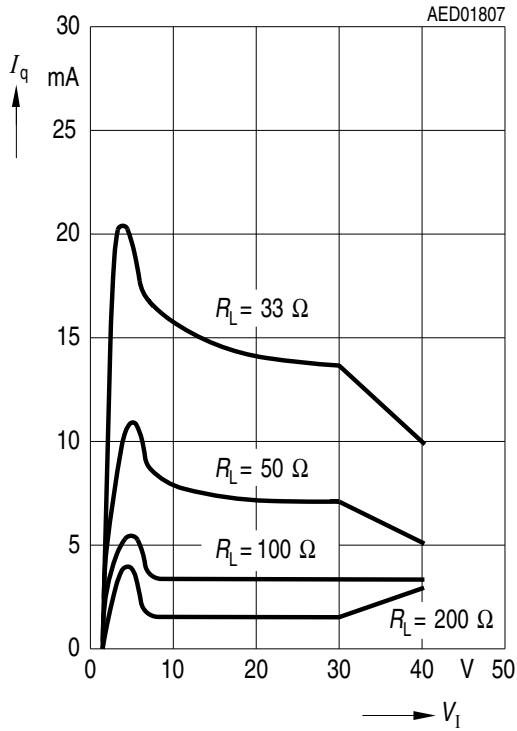

Sense threshold V_{SI} versus temperature T_j

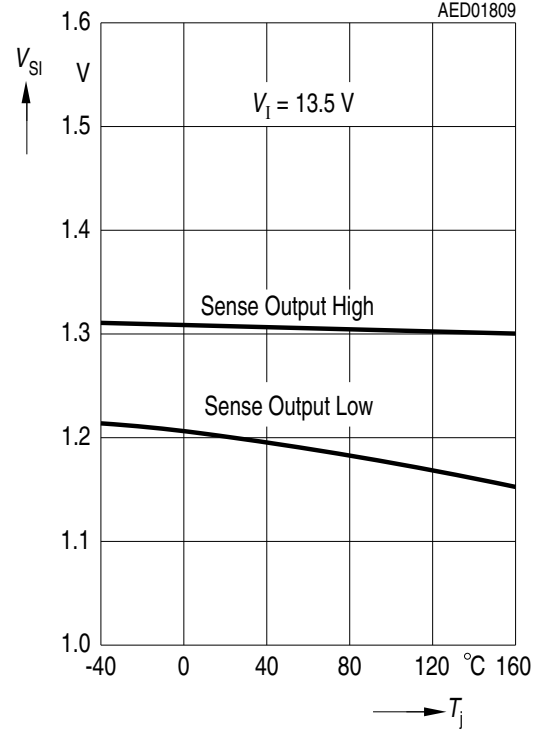

Output voltage V_Q versus input voltage V_I

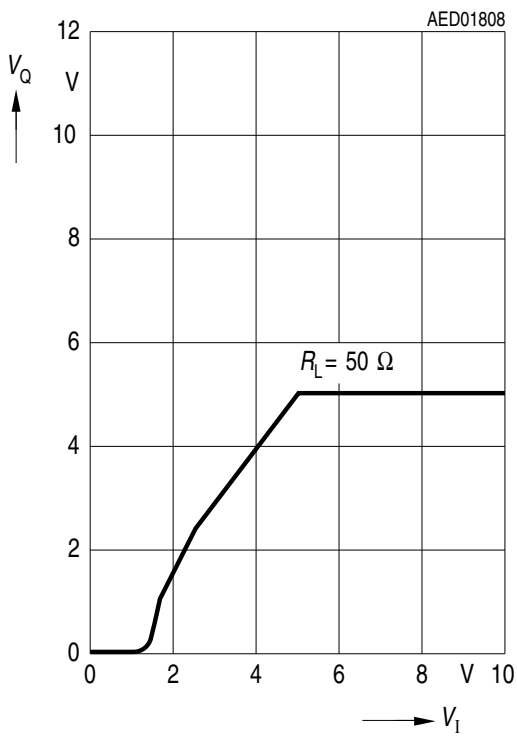

Output voltage V_Q versus temperature T_j

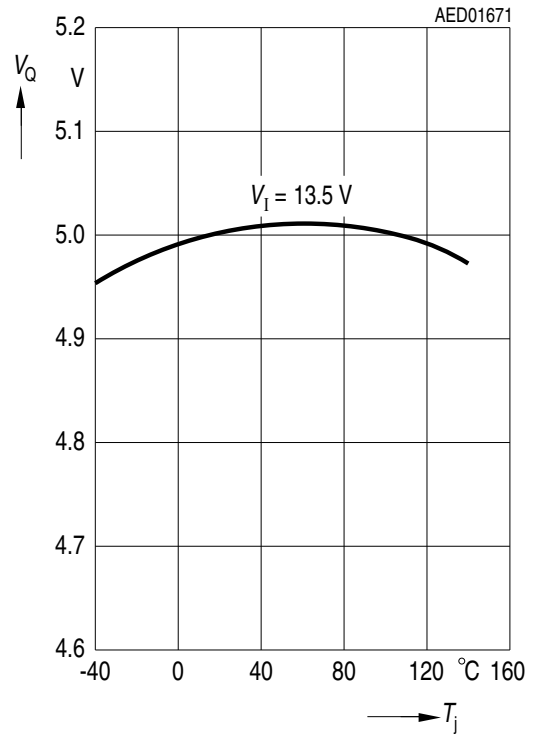

Application information

Output current I_Q versus input voltage V_I

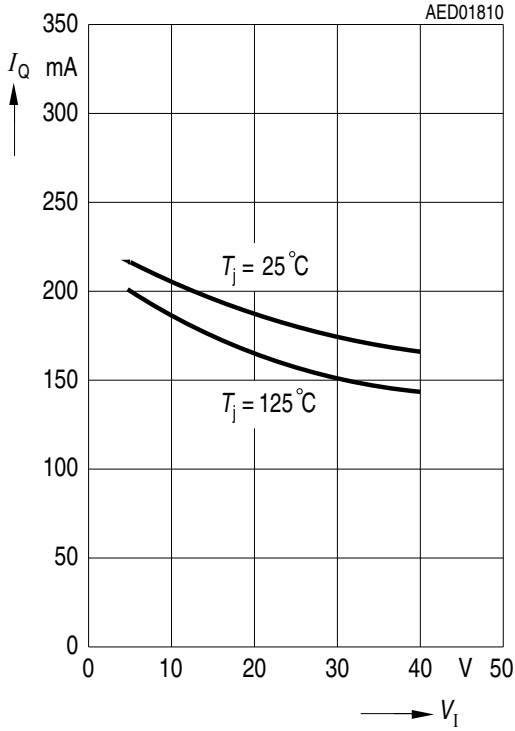

Current consumption I_q versus output current I_Q

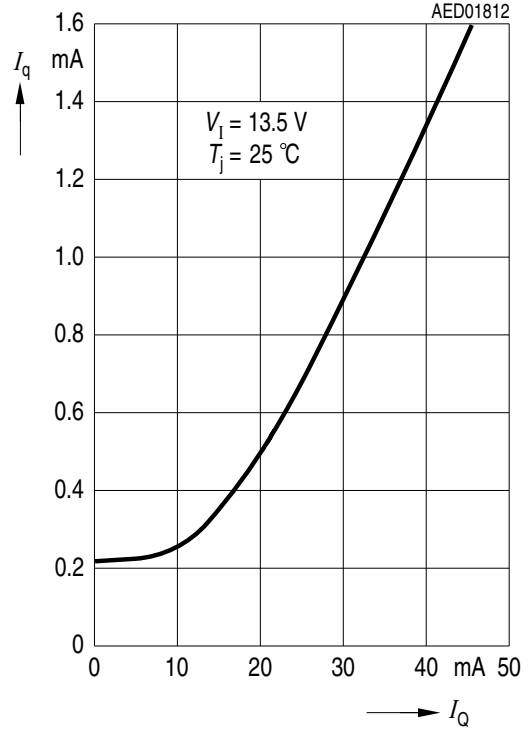

Current consumption I_q versus output current I_Q

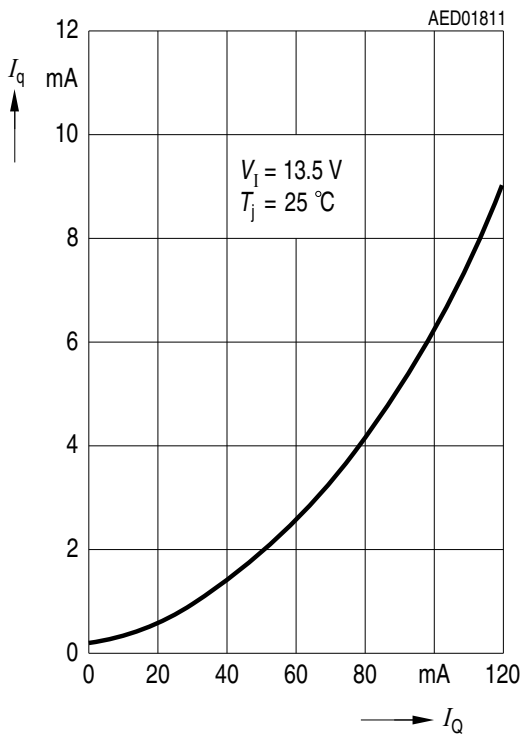

Package information

6 Package information

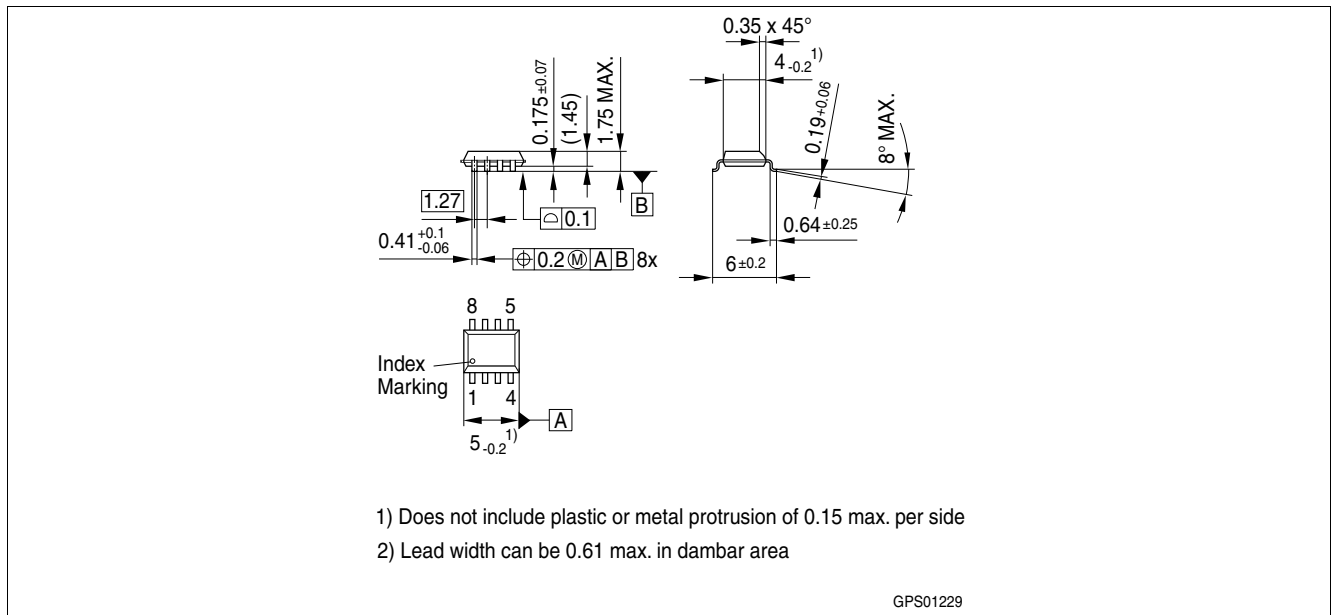

Figure 7 PG-DSO-8 (Plastic Dual Small Outline)¹⁾

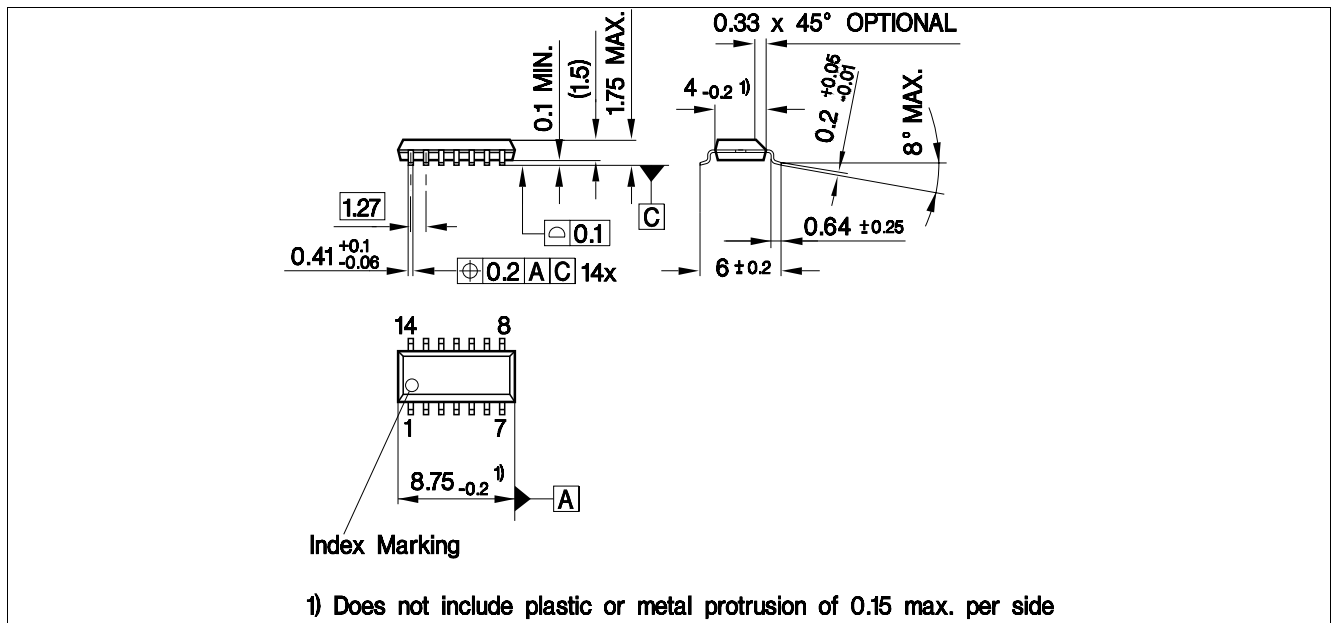

Figure 8 PG-DSO-14

Green Product (RoHS compliant)

To meet the world-wide customer requirements for environmentally friendly products and to be compliant with government regulations the device is available as a green product. Green products are RoHS-Compliant (i.e Pb-free finish on leads and suitable for Pb-free soldering according to IPC/JEDEC J-STD-020).

Further information on packages

<https://www.infineon.com/packages>

1) Dimensions in mm

Revision history

7 Revision history

Revision	Date	Changes
2.5	2018-11-19	Updated package drawing “PG-DSO-14” Editorial changes
2.4	2007-03-20	Initial version of RoHS-compliant derivate of TLE4279 Page 1: AEC certified statement added Page1 and 15: RoHS compliance statement and Green product feature added Package changed to RoHS compliant version Legal disclaimer updated

Trademarks

All referenced product or service names and trademarks are the property of their respective owners.

Edition 2018-11-19

Published by

Infineon Technologies AG

81726 Munich, Germany

© 2018 Infineon Technologies AG.

All Rights Reserved.

Do you have a question about any aspect of this document?

Email: erratum@infineon.com

Document reference

Z8F55294584

IMPORTANT NOTICE

The information given in this document shall in no event be regarded as a guarantee of conditions or characteristics ("Beschaffheitsgarantie").

With respect to any examples, hints or any typical values stated herein and/or any information regarding the application of the product, Infineon Technologies hereby disclaims any and all warranties and liabilities of any kind, including without limitation warranties of non-infringement of intellectual property rights of any third party.

In addition, any information given in this document is subject to customer's compliance with its obligations stated in this document and any applicable legal requirements, norms and standards concerning customer's products and any use of the product of Infineon Technologies in customer's applications.

The data contained in this document is exclusively intended for technically trained staff. It is the responsibility of customer's technical departments to evaluate the suitability of the product for the intended application and the completeness of the product information given in this document with respect to such application.

For further information on technology, delivery terms and conditions and prices, please contact the nearest Infineon Technologies Office (www.infineon.com).

WARNINGS

Due to technical requirements products may contain dangerous substances. For information on the types in question please contact your nearest Infineon Technologies office.

Except as otherwise explicitly approved by Infineon Technologies in a written document signed by authorized representatives of Infineon Technologies, Infineon Technologies' products may not be used in any applications where a failure of the product or any consequences of the use thereof can reasonably be expected to result in personal injury.

X-ON Electronics

Largest Supplier of Electrical and Electronic Components

Click to view similar products for [LDO Voltage Regulators](#) category:

Click to view products by [Infineon](#) manufacturer:

Other Similar products are found below :

[AP7363-SP-13](#) [L79M05TL-E](#) [PT7M8202B12TA5EX](#) [TCR3DF185,LM\(CT](#) [MP2013GQ-33-Z](#) [059985X](#) [NCP4687DH15T1G](#) [701326R](#)
[TCR2EN28,LF\(S](#) [NCV8170AXV250T2G](#) [TCR2EN18,LF\(S](#) [AP7315-25W5-7](#) [IFX30081LDVGRNXUMA1](#) [NCV47411PAAJR2G](#)
[AP2113KTR-G1](#) [AP2111H-1.2TRG1](#) [ZLDO1117QK50TC](#) [AZ1117IH-1.8TRG1](#) [TCR3DG12,LF](#) [MIC5514-3.3YMT-T5](#) [MIC5512-1.2YMT-](#)
[T5](#) [MIC5317-2.8YM5-T5](#) [SCD7912BTG](#) [NCP154MX180270TAG](#) [SCD33269T-5.0G](#) [NCV8170BMX330TCG](#) [NCV8170AMX120TCG](#)
[NCP706ABMX300TAG](#) [NCP153MX330180TCG](#) [NCP114BMX075TCG](#) [MC33269T-3.5G](#) [CAT6243-ADJCMT5T](#) [TCR3DG33,LF](#)
[AP2127N-1.0TRG1](#) [TCR4DG35,LF](#) [LT1117CST-3.3](#) [LT1117CST-5](#) [TAR5S15U\(TE85L,F\)](#) [TAR5S18U\(TE85L,F\)](#) [TCR3UG19A,LF](#)
[TCR4DG105,LF](#) [NCV8170AMX360TCG](#) [MIC94310-NYMT-T5](#) [TLE4268GSXUMA2](#) [NCV8186BMN175TAG](#) [NCP715SQ15T2G](#)
[MIC5317-3.0YD5-T5](#) [NCV563SQ18T1G](#) [MIC5317-2.8YD5-T5](#) [NCP715MX30TBG](#)