



Features

- Output voltage $5\text{ V} \pm 2\%$
- Very low current consumption
- 450 mA current capability
- Power Good Feature
- Very low-drop voltage
- Short-circuit-proof
- Reverse polarity proof
- Suitable for use in automotive electronics
- Green Product (RoHS compliant)
- AEC Qualified

Functional Description

The TLE 4290 is a monolithic integrated low drop voltage regulator which can supply loads up to 450 mA with power good feature. An input voltage up to 42 V is regulated to $V_{Q,nom} = 5.0\text{ V}$. The device is designed to supply μ -controllers in the severe environment of automotive applications. Therefore it is protected against overload, short circuit and over temperature conditions. Of course the TLE 4290 can be used also in all other applications, where a stabilized 5 V voltage is required.

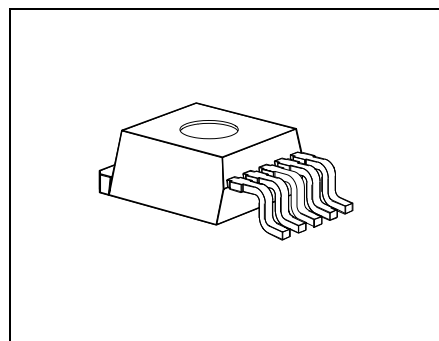
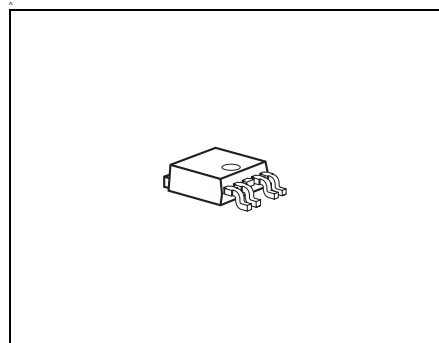

Type	Package
TLE 4290 D	PG-TO252-5-11
TLE 4290 G	PG-TO263-5-1

Power Good

The Power Good PG pin informs e.g. the microcontroller in case the output voltage has fallen below the lower threshold $V_{Q,pgt-d}$ of typ. 3.65 V. Connecting the regulator to a battery voltage at first the power good signal remains LOW. When the output voltage has reached the higher threshold $V_{Q,pgt-i}$ the power good output remains still LOW for the power good delay time t_{rd} . Afterwards the power good output turns HIGH. The delay time can be set by the user with an external capacitor at pin D according to the requirements of the application.

The Power Good circuitry supervises the output voltage. In case V_Q falls below the lower Power Good switching threshold $V_{Q,pgt-d}$ the PG output is set LOW after the Power Good reaction time. The Power Good LOW signal is generated down to an output voltage V_Q to 1 V. A LOW signal at the Power Good pin informs that the battery was lost and memory is no longer valid.

The feature should be used in combination with a microcontroller with internal reset.

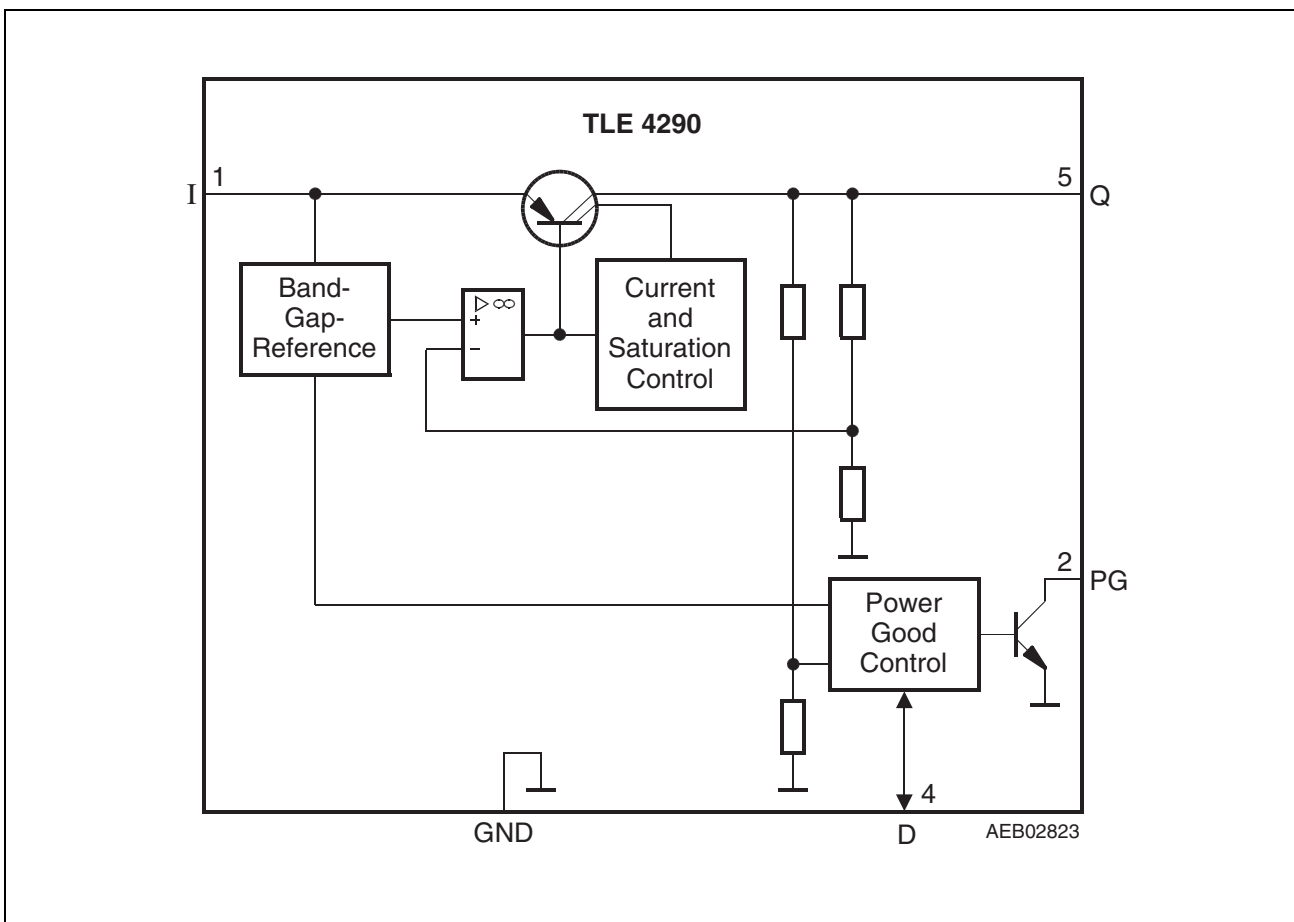

Figure 1 Block Diagram

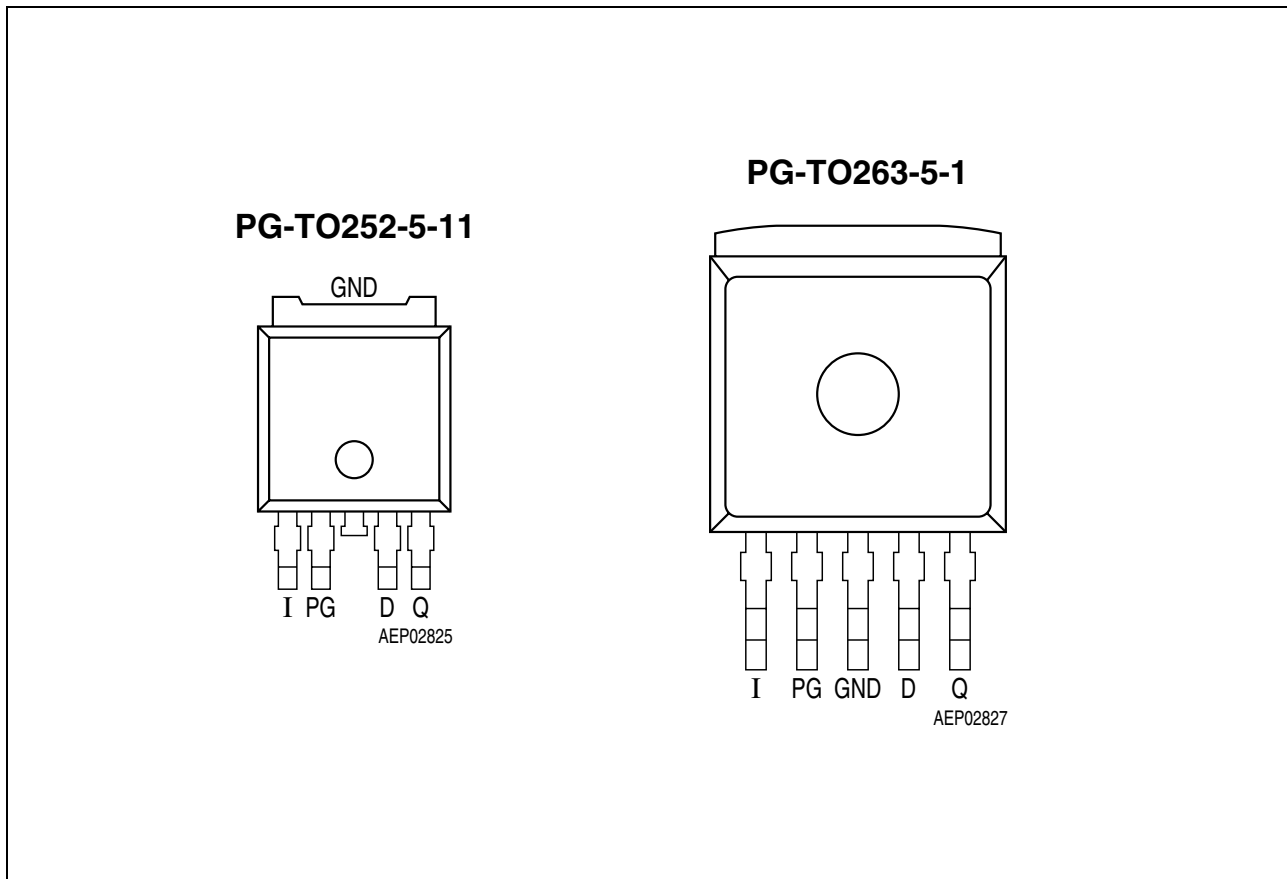

Figure 2 Pin Configuration (top view)

Table 1 Pin Definitions and Functions

Pin No.	Symbol	Function
1	I	Input; block to ground directly at the IC with a ceramic capacitor.
2	PG	Power Good; open collector output. Add a pull-up resistor of > 5 kΩ to pin Q.
3	GND	Ground; Pin 3 internally connected to heatsink.
4	D	Delay; connect a capacitor to GND for setting power good delay time.
5	Q	Output; block to ground with a capacitor, $C \geq 22 \mu\text{F}$ ESR < 5 Ω at 10 kHz.

Table 2 Absolute Maximum Ratings

Parameter	Symbol	Limit Values		Unit	Test Condition
		Min.	Max.		
Input I					
Voltage	V_I	-42	45	V	–
Current	I_I	–	–	–	Internally limited
Output Q					
Voltage	V_Q	-1.0	16	V	–
Current	I_Q	–	–	–	Internally limited
Power Good Output PG					
Voltage	V_{PG}	-0.3	25	V	–
Current	I_{PG}	-5	5	mA	–
Delay D					
Voltage	V_D	-0.3	7	V	–
Current	I_D	-2	2	mA	–
Temperature					
Junction temperature	T_j	-40	150	°C	–
Storage temperature	T_{stg}	-50	150	°C	–

Note: Stresses above those listed here may cause permanent damage to the device. Exposure to absolute maximum rating conditions for extended periods may affect device reliability.

Table 3 Operating Range

Parameter	Symbol	Limit Values		Unit	Remarks
		Min.	Max.		
Input voltage	V_I	5.5	42	V	–
Junction temperature	T_j	-40	150	°C	–

Thermal Resistance

Junction case	R_{thj-c}	–	4	K/W	–
Junction ambient	R_{thj-a}	–	53	K/W	TO263 ¹⁾
Junction ambient	R_{thj-a}	–	78	K/W	TO252 ¹⁾

1) Worst case, regarding peak temperature; zero airflow; mounted on a PCB FR4, 80 × 80 × 1.5 mm³, heat sink area 300 mm²

Note: In the operating range, the functions given in the circuit description are fulfilled.

Table 4 Characteristics
 $V_I = 13.5 \text{ V}; -40 \text{ }^\circ\text{C} < T_j < 150 \text{ }^\circ\text{C}$ (unless otherwise specified)

Parameter	Symbol	Limit Values			Unit	Measuring Condition
		Min.	Typ.	Max.		
Output						
Output voltage	V_Q	4.9	5.0	5.1	V	$5 \text{ mA} < I_Q < 400 \text{ mA};$ $6 \text{ V} < V_I < 28 \text{ V}$
Output voltage	V_Q	4.9	5.0	5.1	V	$5 \text{ mA} < I_Q < 200 \text{ mA};$ $6 \text{ V} < V_I < 40 \text{ V}$
Output current limitation	I_Q	450	700	–	mA	1)
Current consumption; $I_q = I_I - I_Q$	I_q	–	200	230	μA	$I_Q = 1 \text{ mA};$ $T_j = 25 \text{ }^\circ\text{C}$
Current consumption; $I_q = I_I - I_Q$	I_q	–	200	255	μA	$I_Q = 1 \text{ mA};$ $T_j \leq 85 \text{ }^\circ\text{C}$
Current consumption; $I_q = I_I - I_Q$	I_q	–	5	12	mA	$I_Q = 250 \text{ mA}$
Current consumption; $I_q = I_I - I_Q$	I_q	–	12	25	mA	$I_Q = 400 \text{ mA}$
Drop voltage	V_{dr}	–	250	500	mV	$I_Q = 300 \text{ mA}$ $V_{dr} = V_I - V_Q$ 1)
Load regulation	$\Delta V_{Q,lo}$	-30	15	30	mV	$V_I = 6 \text{ V};$ $I_Q = 5 \text{ mA to } 400 \text{ mA}$
Line regulation	$\Delta V_{Q,li}$	-15	5	15	mV	$V_I = 8 \text{ V to } 32 \text{ V};$ $I_Q = 5 \text{ mA}$
Power supply ripple rejection	$PSRR$	–	60	–	dB	$f_r = 100 \text{ Hz};$ $V_r = 0.5 \text{ Vpp}$
Temperature output voltage drift	dV_Q/dT	–	0.5	–	mV/K	–
Output Capacitor	C_Q	22	–	–	μF	ESR < 5 Ω in the operation range
Power Good Output PG and Delay Timing D						
Power Good switching threshold	$V_{Q,pgt-i}$	4.45	4.65	4.80	V	V_Q increasing
Power Good switching threshold	$V_{Q,pgt-d}$	3.50	3.65	3.80	V	V_Q decreasing

Table 4 Characteristics (cont'd)
 $V_I = 13.5\text{ V}; -40\text{ }^\circ\text{C} < T_j < 150\text{ }^\circ\text{C}$ (unless otherwise specified)

Parameter	Symbol	Limit Values			Unit	Measuring Condition
		Min.	Typ.	Max.		
Power Good output low voltage	V_{PGL}	–	0.2	0.4	V	$R_{PG} \geq 5\text{ k}\Omega;$ $V_Q > 1\text{ V}$
Power Good output leakage current	I_{PGH}	–	0	2	μA	$V_{PG} > 4.5\text{ V}$
Power Good charging current	$I_{D,c}$	3	6	9	μA	$V_D = 1\text{ V}$
Upper timing threshold	V_{DU}	1.5	1.8	2.2	V	–
Lower timing threshold	V_{DL}	0.60	0.85	1.10	V	–
Power Good delay time	t_{rd}	10	16	22	ms	$C_D = 47\text{ nF}$
Power Good reaction time	t_{rr}	0.2	0.5	2.0	μs	$C_D = 47\text{ nF}$

 1) Measured when the output voltage V_Q has dropped 100 mV from the nominal value obtained at $V_I = 13.5\text{ V}$.

Note: The listed characteristics are ensured over the operating range of the integrated circuit. Typical characteristics specify mean values expected over the production spread. If not otherwise specified, typical characteristics apply at $T_a = 25\text{ }^\circ\text{C}$ and the given supply voltage.

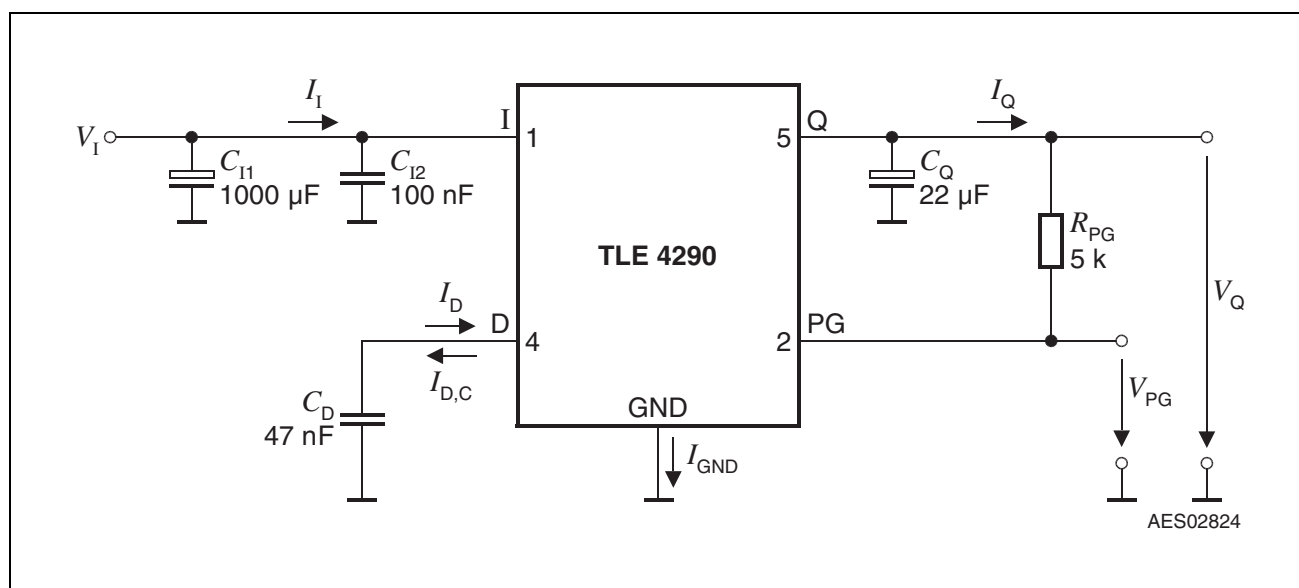
Figure 3 Test Circuit

Application Information

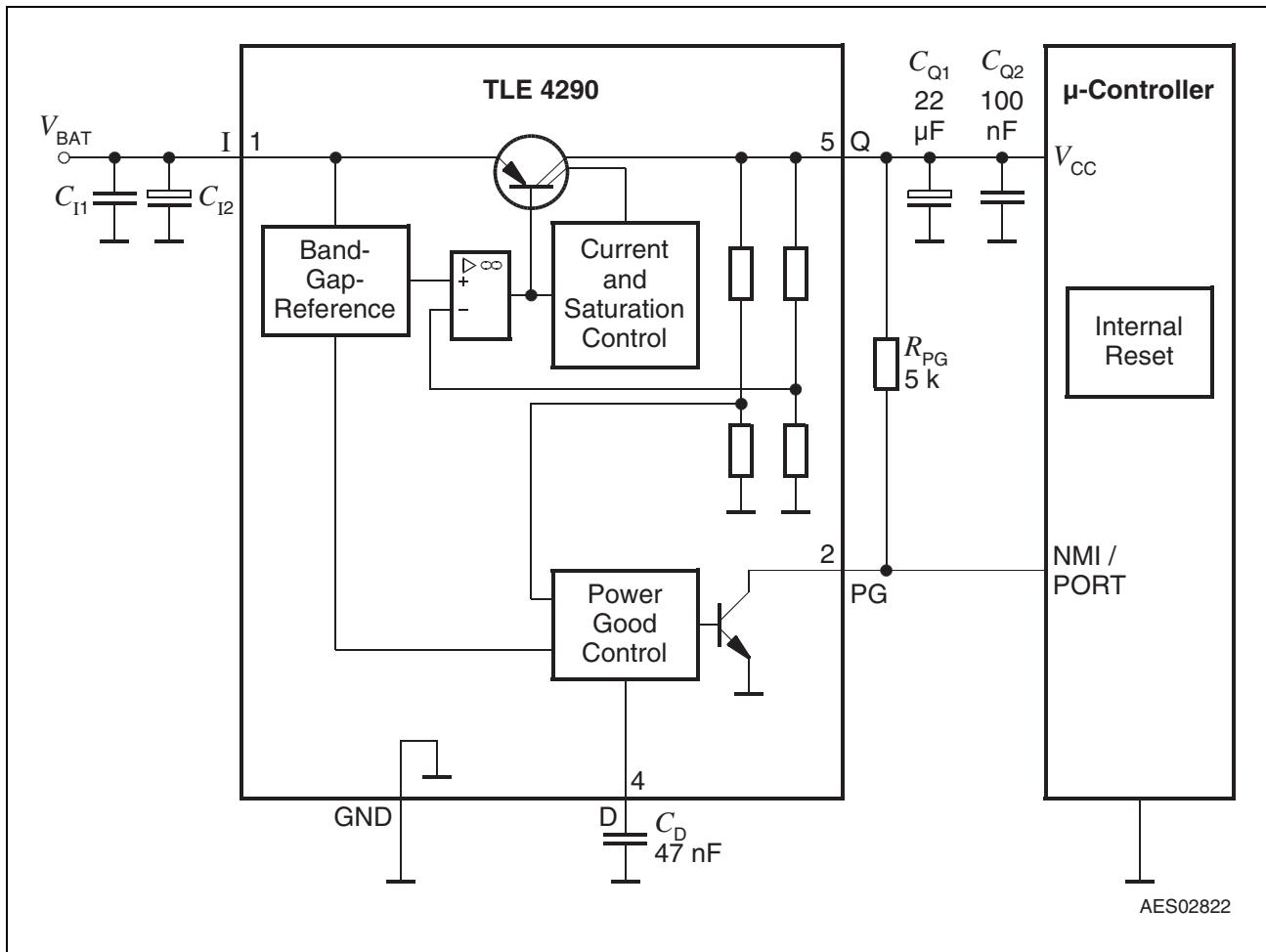

Figure 4 Application Diagram

Input, Output

An input capacitor is necessary for damping line influences. A resistor of approx. 1 Ω in series with C_I , can damp the LC of the input inductivity and the input capacitor.

The TLE 4290 requires an output capacitor of at least 22 μF with an ESR below 5 Ω for stability.

Power Good

The Power Good pin informs e.g. the micro-controller in case the output voltage has fallen below a threshold of typ. 3.65 V. When the battery voltage is supplied the Power Good signal indicates a loss of memory due to missing power. After the Memory Good switching threshold is reached the Power Good output remains low for the Power Good delay time. This time can be set by the user with an external capacitor at pin D according to the requirements of the application, e.g. the time until the microcontroller is initialized and ready to receive any information.

The power good circuit supervises the output voltage. In case V_Q falls below the Power Good switching threshold the Power Good output PG is set LOW after the power good reaction time. The power good LOW signal is generated down to an output voltage V_Q to 1 V. A LOW signal at the power good pin informs that the battery was lost and memory is no longer valid.

The feature should only be used in combination to a microcontroller with internal reset. For the power good delay time after the output voltage of the regulator is above the reset threshold, the reset signal is set High again. The reset delay time is defined by the reset delay capacitor C_D at pin D.

The Power Good delay time is defined by the charging time of an external delay capacitor C_D .

$$C_D = (t_{rd} \times I_{D,c}) / \Delta V \tag{1}$$

With:

- C_D = Power Good delay capacitor
- t_{rd} = Power Good delay time
- $\Delta V = V_{DU}$, typical 1.8 V
- $I_{D,c}$ = Charge current typical 6 μA

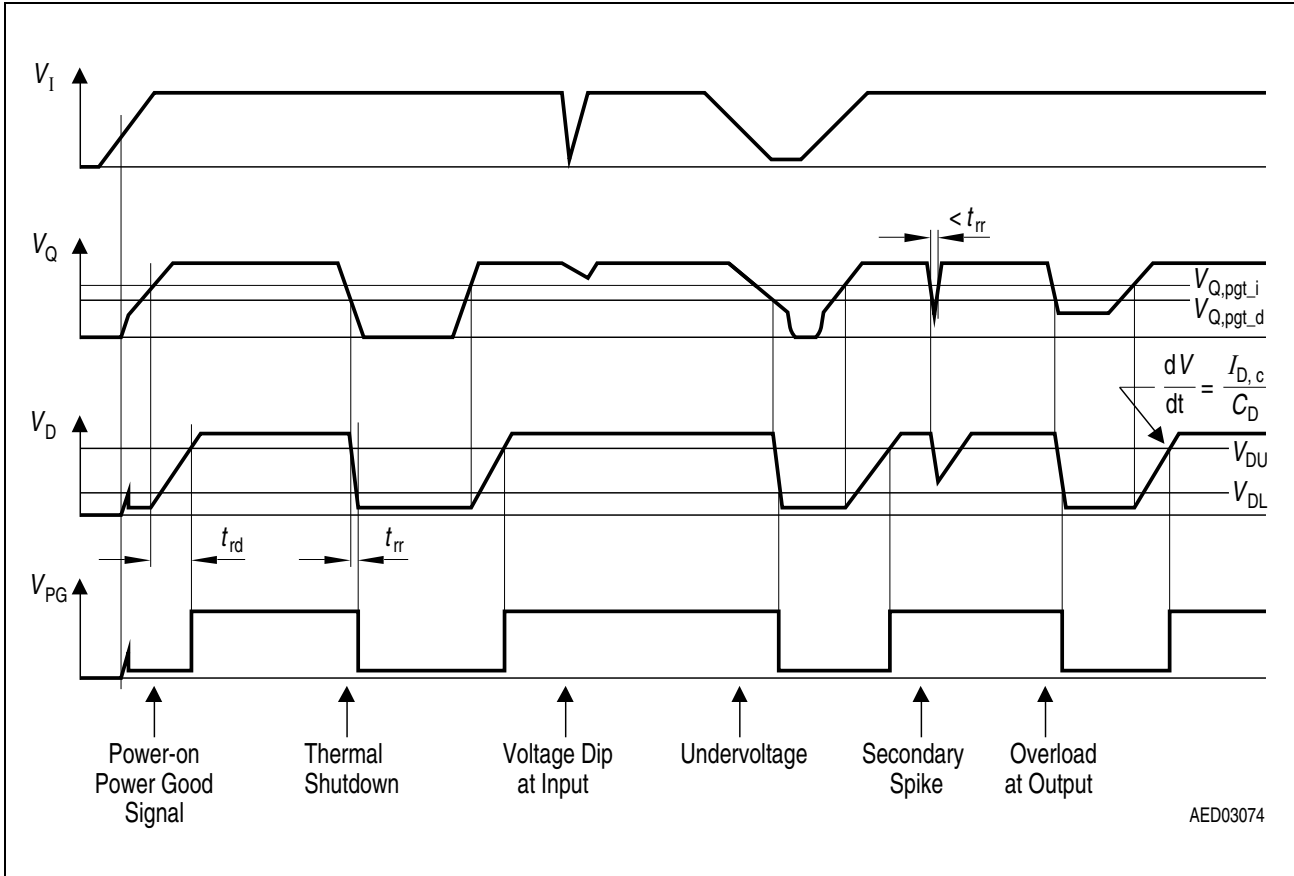

Figure 5 Power Good Timing

The power good reaction time t_{rr} is the time it takes the voltage regulator to set power good output PG LOW after the output voltage has dropped below the power good switching threshold. It is typically 0.5 μ s for delay capacitor of 47 nF. For other values for C_D the reaction time can be estimated using the following equation:

$$t_{rr} = 10 \text{ ns/nF} \times C_D \quad (2)$$

The Power Good output is an open collector output. It requires externally a pull-up resistor of at least 5 k Ω to Q.

Typical Performance Characteristics

Output Voltage V_Q versus Temperature T_j

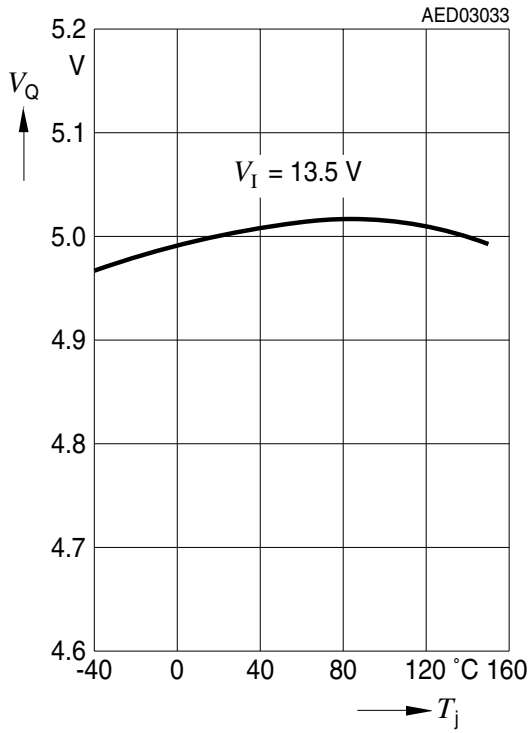

Output Voltage V_Q versus Input Voltage V_I

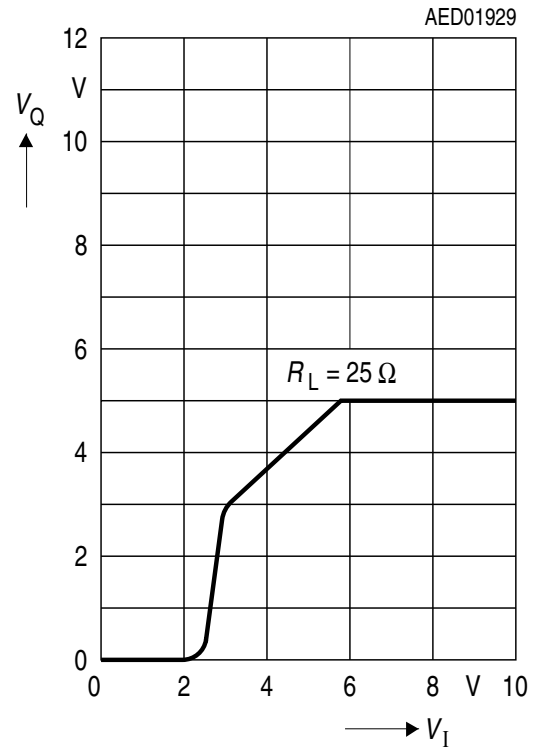

Output Current I_Q versus Temperature T_j

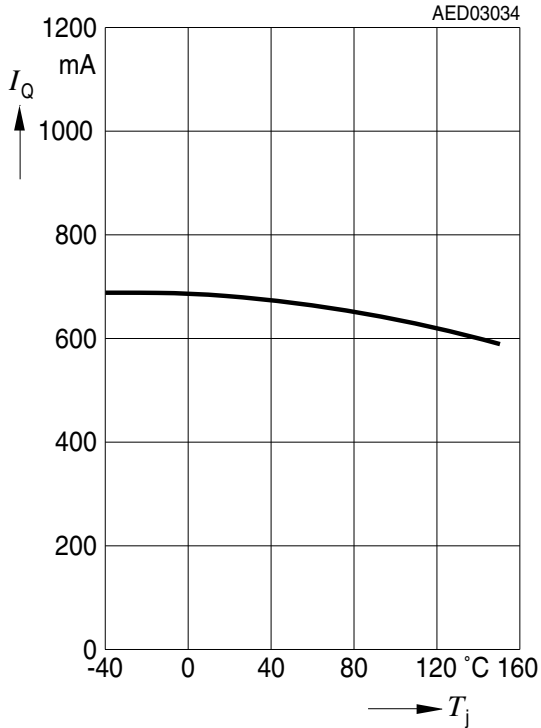

Output Current I_Q versus Input Voltage V_I

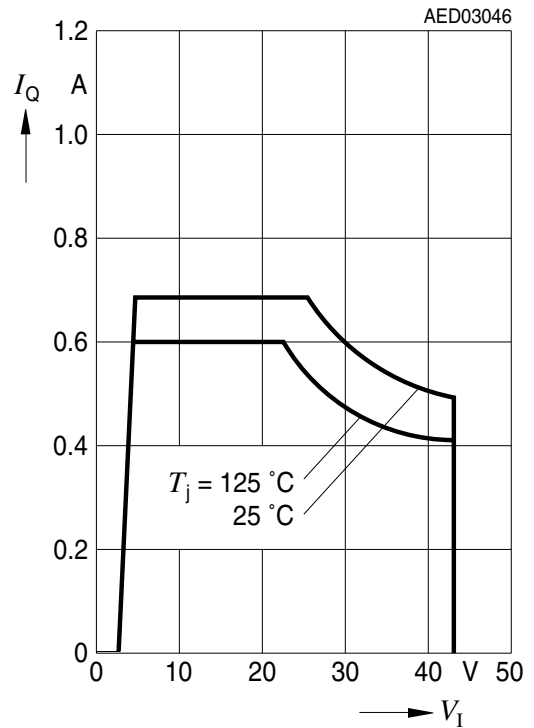

Current Consumption I_q versus Output Current I_Q ; $T_j = 25$ °C

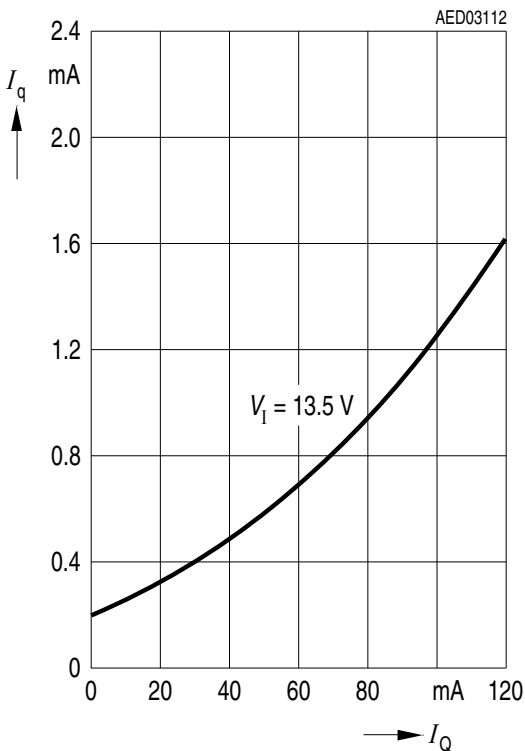

Current Consumption I_q versus Output Current I_Q

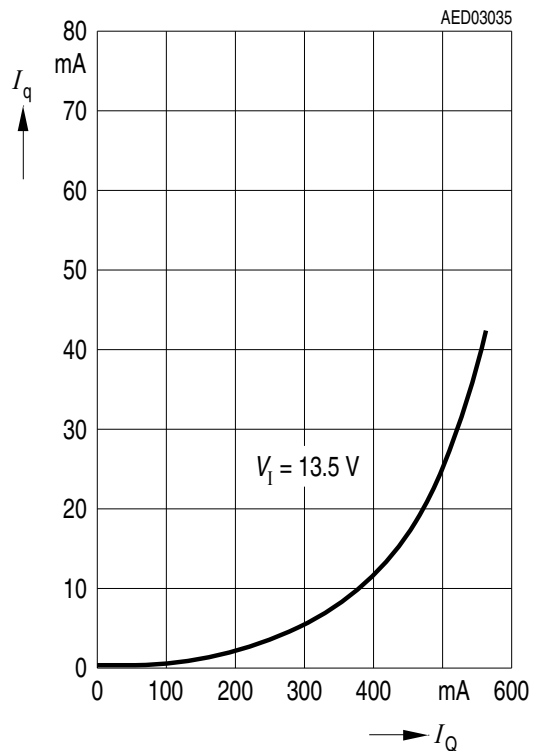

Drop Voltage V_{dr} versus Output Current I_Q

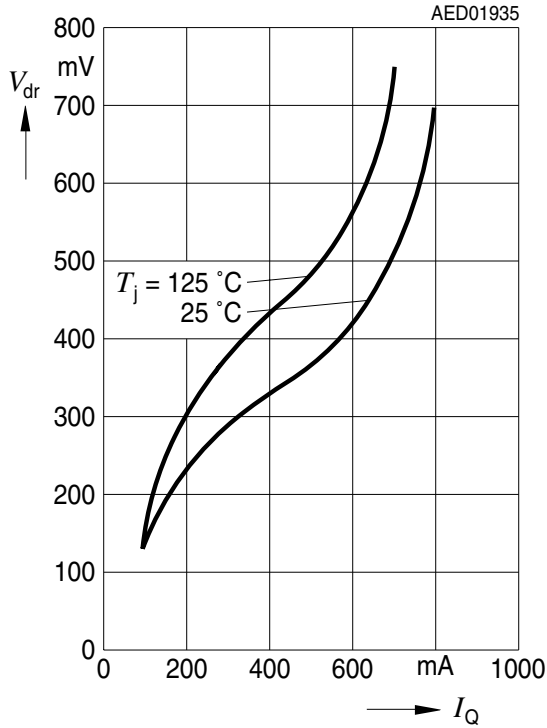

Charge Current $I_{D,c}$ versus Temperature T_j

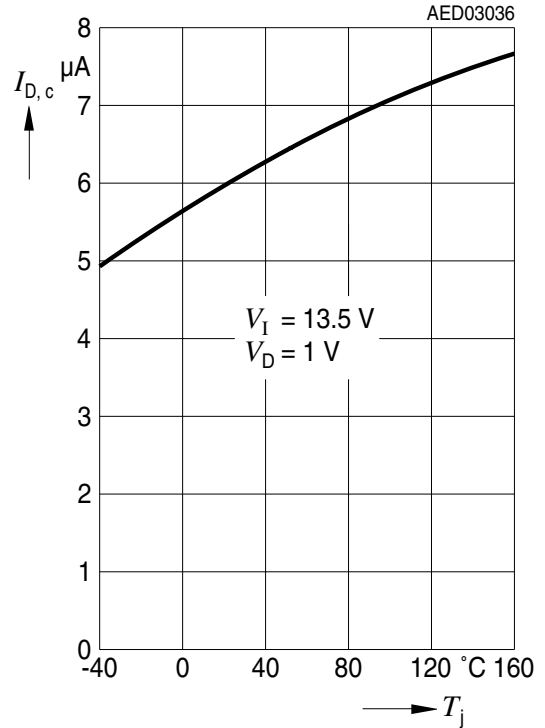

Upper Timing Threshold V_{DU} versus Temperature T_j

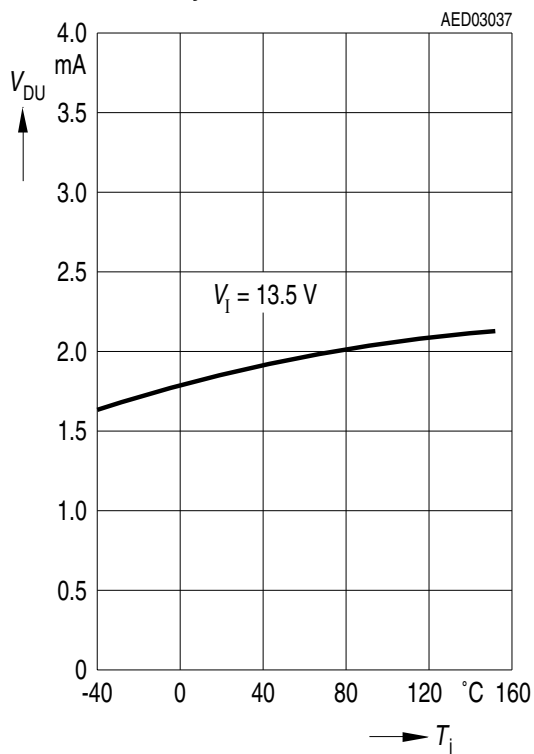

Package Outlines

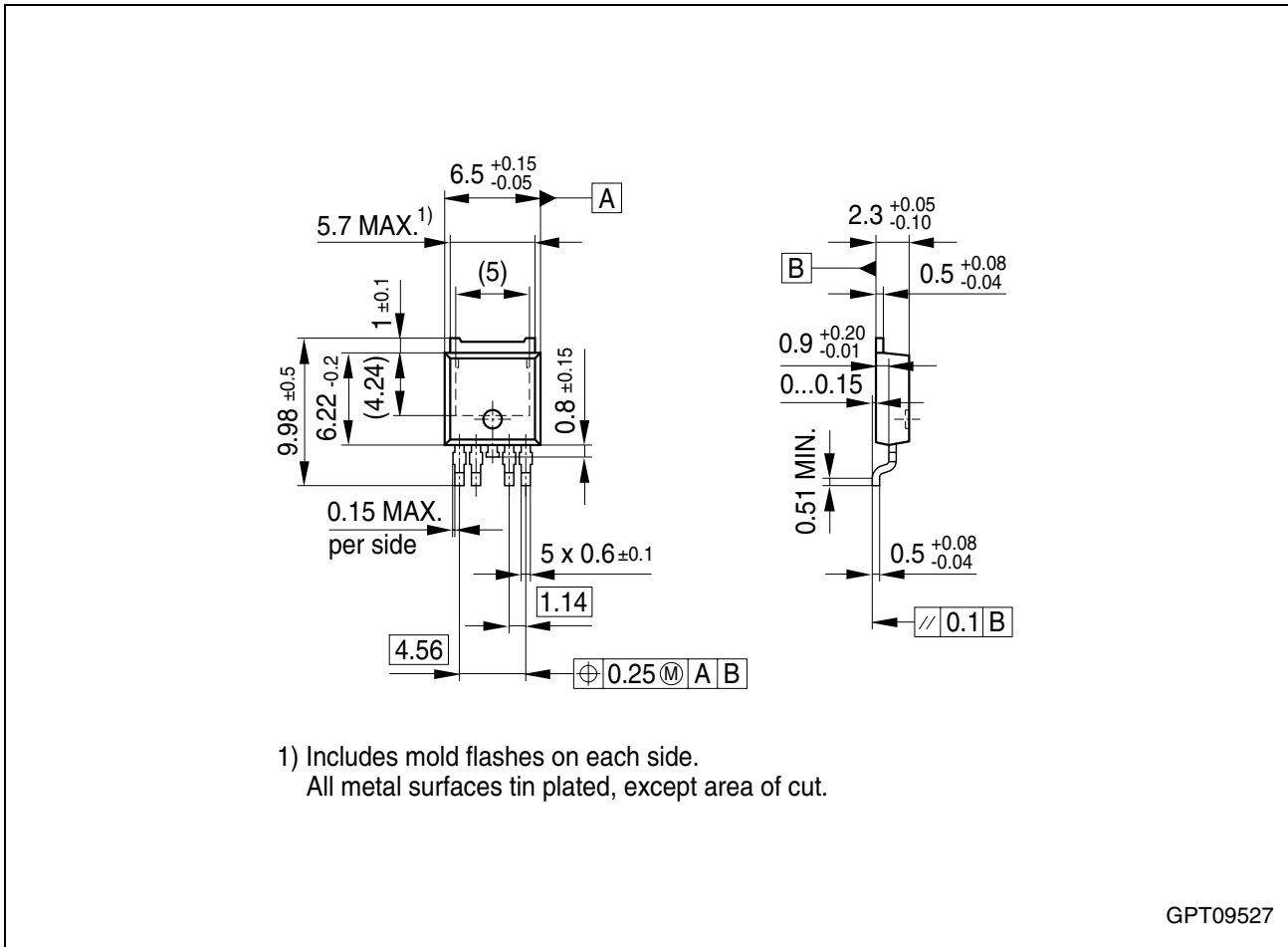

Figure 6 PG-TO252-5-11 (Plastic Transistor Single Outline)

Green Product (RoHS compliant)

To meet the world-wide customer requirements for environmentally friendly products and to be compliant with government regulations the device is available as a green product. Green products are RoHS-Compliant (i.e Pb-free finish on leads and suitable for Pb-free soldering according to IPC/JEDEC J-STD-020).

You can find all of our packages, sorts of packing and others in our Infineon Internet Page "Products": <http://www.infineon.com/products>.

SMD = Surface Mounted Device

Dimensions in mm

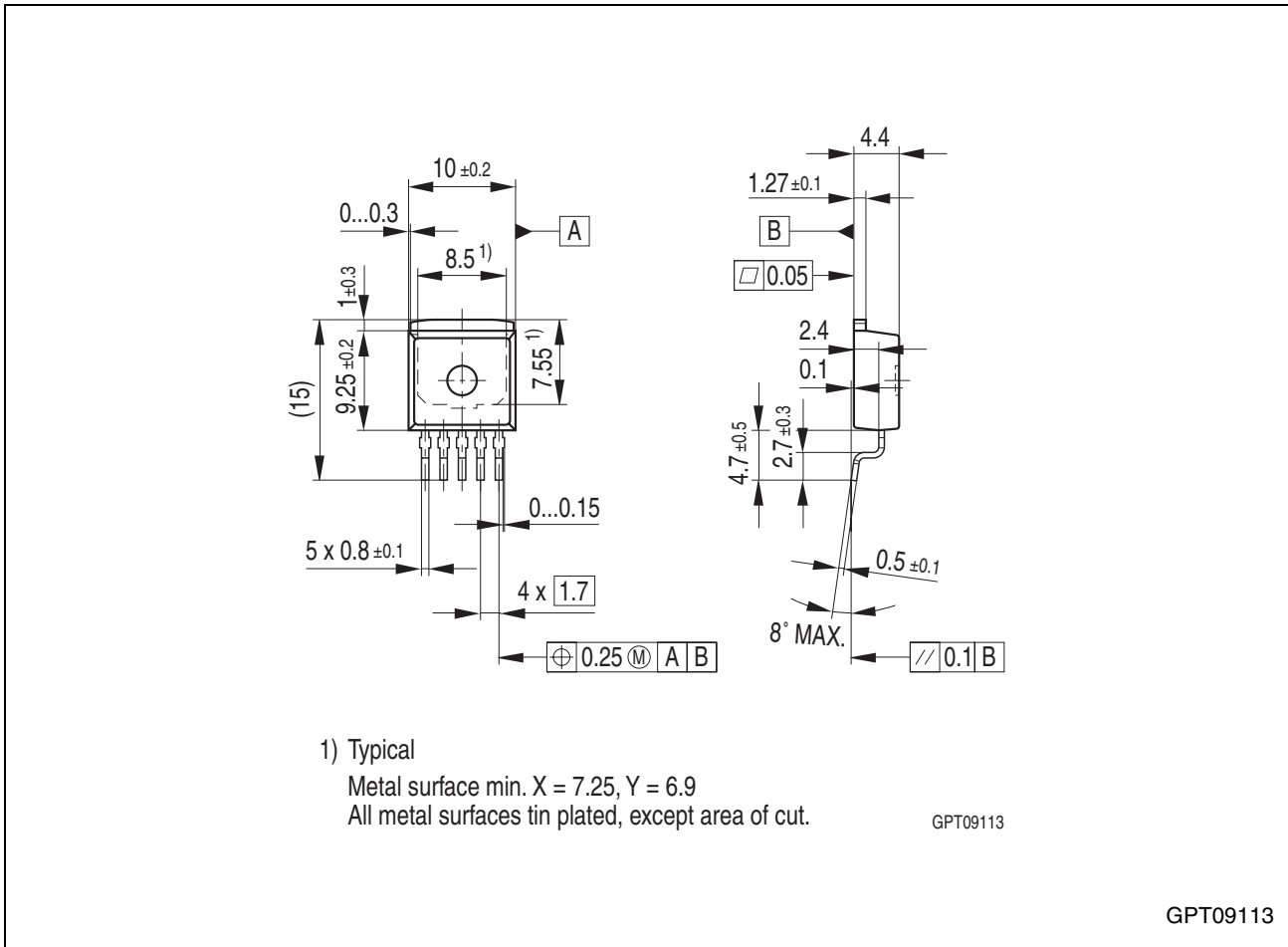

Figure 7 PG-TO263-5-1 (Plastic Transistor Single Outline)

Green Product (RoHS compliant)

To meet the world-wide customer requirements for environmentally friendly products and to be compliant with government regulations the device is available as a green product. Green products are RoHS-Compliant (i.e Pb-free finish on leads and suitable for Pb-free soldering according to IPC/JEDEC J-STD-020).

You can find all of our packages, sorts of packing and others in our Infineon Internet Page "Products": <http://www.infineon.com/products>.

SMD = Surface Mounted Device

Dimensions in mm

Revision History

Version	Date	Changes
Rev. 1.7	2007-03-20	Initial version of RoHS-compliant derivate of TLE 4290 Page 1 : AEC certified statement added Page 1 and Page 14 : RoHS compliance statement and Green product feature added Page 1 and Page 14 : Package changed to RoHS compliant version Legal Disclaimer updated

Edition 2007-03-20

**Published by
Infineon Technologies AG
81726 Munich, Germany**

**© 2007 Infineon Technologies AG
All Rights Reserved.**

Legal Disclaimer

The information given in this document shall in no event be regarded as a guarantee of conditions or characteristics. With respect to any examples or hints given herein, any typical values stated herein and/or any information regarding the application of the device, Infineon Technologies hereby disclaims any and all warranties and liabilities of any kind, including without limitation, warranties of non-infringement of intellectual property rights of any third party.

Information

For further information on technology, delivery terms and conditions and prices, please contact the nearest Infineon Technologies Office (www.infineon.com).

Warnings

Due to technical requirements, components may contain dangerous substances. For information on the types in question, please contact the nearest Infineon Technologies Office.

Infineon Technologies components may be used in life-support devices or systems only with the express written approval of Infineon Technologies, if a failure of such components can reasonably be expected to cause the failure of that life-support device or system or to affect the safety or effectiveness of that device or system. Life support devices or systems are intended to be implanted in the human body or to support and/or maintain and sustain and/or protect human life. If they fail, it is reasonable to assume that the health of the user or other persons may be endangered.

X-ON Electronics

Largest Supplier of Electrical and Electronic Components

Click to view similar products for [LDO Voltage Regulators](#) category:

Click to view products by [Infineon](#) manufacturer:

Other Similar products are found below :

[M38D29FFHP#U1](#) [702103A](#) [717726C](#) [742457H](#) [MP20051DN-LF-Z](#) [R5F111PGGFB#30](#) [AP7363-SP-13](#) [NCP103AMX285TCG](#)
[NCV8664CST33T3G](#) [NCV8752AMX28TCG](#) [L9454](#) [AP7362-HA-7](#) [LX13043CLD](#) [TCR3DF185,LM\(CT](#) [TCR3DF24,LM\(CT](#)
[TCR3DF285,LM\(CT](#) [TCR3DF31,LM\(CT](#) [TCR3DF45,LM\(CT](#) [TLF4949EJ](#) [MP2013GQ-33-Z](#) [L9708](#) [L970813TR](#) [030014BB](#) [059985X](#)
[EAN61387601](#) [EAN61573601](#) [NCP121AMX173TCG](#) [NCP4687DH15T1G](#) [NCV8703MX30TCG](#) [701326R](#) [702087BB](#) [755078E](#)
[TCR2EN28,LF\(S](#) [LM1117DT-1.8/NO](#) [LT1086CM#TRPBF](#) [AZ1085S2-1.5TRE1](#) [MAX15101EWL+T](#) [NCV8170AXV250T2G](#)
[TCR3DF27,LM\(CT](#) [TCR3DF19,LM\(CT](#) [TCR3DF125,LM\(CT](#) [TCR2EN18,LF\(S](#) [MAX15103EWL+T](#) [TS2937CZ-5.0 C0](#) [MAX8878EUK30-](#)
[T](#) [MAX663CPA](#) [NCV4269CPD50R2G](#) [NCV8716MT30TBG](#) [AZ1117IH-1.2TRG1](#) [MP2013GQ-P](#)