

TLE4678-2

Low Drop Out Linear Voltage Regulator

5 V Fixed Output Voltage
TLE4678-2LD

Data Sheet

Rev. 1.0, 2014-03-03

Table of Contents

1	Overview	3
2	Block Diagram	4
3	Pin Configuration	5
3.1	Pin Configuration PG-TSON10	5
4	General Product Characteristics	7
4.1	Absolute Maximum Ratings	7
4.2	Functional Range	8
4.3	Thermal Resistance	8
5	Voltage Regulator	9
5.1	Description Voltage Regulator	9
5.2	Electrical Characteristics Voltage Regulator	10
5.3	Typical Performance Characteristics Voltage Regulator	11
6	Current Consumption	14
6.1	Electrical Characteristics Current Consumption	14
6.2	Typical Performance Characteristics Current Consumption	15
7	Reset Function	16
7.1	Description Reset Function	16
7.2	Electrical Characteristics Reset Function	19
7.3	Typical Performance Characteristics Reset Function	21
8	Watchdog Function	22
8.1	Description	22
8.2	Electrical Characteristics Watchdog Function	25
8.3	Typical Performance Characteristics Standard Watchdog Function	27
9	Application Information	28
9.1	Application Diagram	28
9.2	Selection of External Components	28
9.3	Thermal Considerations	29
9.4	Reverse Polarity Protection	30
9.5	Further Application Information	30
10	Package Outlines	31
11	Revision History	32



1 Overview

Features

- Output Voltage $5\text{ V} \pm 2\%$
- Current Capability 200 mA
- Ultra Low Current Consumption
- Very Low Drop Out Voltage
- Watchdog Circuit for Monitoring a Microprocessor with Programmable Load-dependent Activating Threshold
- Reset Circuit Sensing the Output Voltage with Programmable Switching Threshold and Delay Time
- Reset Output Active Low Down to $V_{\text{O}} = 1\text{ V}$
- Separated Reset and Watchdog Output
- Excellent Line Transient Robustness
- Maximum Input Voltage $-14\text{ V} \leq V_{\text{I}} \leq +45\text{ V}$
- Reverse Polarity Protection
- Short Circuit Protected
- Overtemperature Shutdown
- Automotive Temperature Range $-40\text{ }^{\circ}\text{C} \leq T_{\text{j}} \leq 150\text{ }^{\circ}\text{C}$
- Available in a small thermally enhanced PG-TSON10 package
- Green Product (RoHS Compliant)
- AEC Qualified



PG-TSON10

Description

The TLE4678-2 is a monolithic integrated low drop out fixed output voltage regulator for loads up to 200 mA. An input voltage of up to 45 V is regulated to an output voltage of 5 V. The integrated reset and watchdog function, as well as several protection circuits, combined with a wide operating temperature range offered by the TLE4678-2 make it suitable for supplying microprocessor systems in automotive environments.

The watchdog circuitry will be disabled in case the output current drops below a programmable threshold, enabling a microcontroller to switch in stand-by mode. Modifying the reset threshold is possible by an optional resistor divider.

The TLE4678-2 is available in the tiny thermally enhanced PG-TSON10 exposed pad package.

Type	Package	Marking
TLE4678-2LD	PG-TSON10	46782LD

2 Block Diagram

For details on the circuit blocks see the respective section in this data sheet.

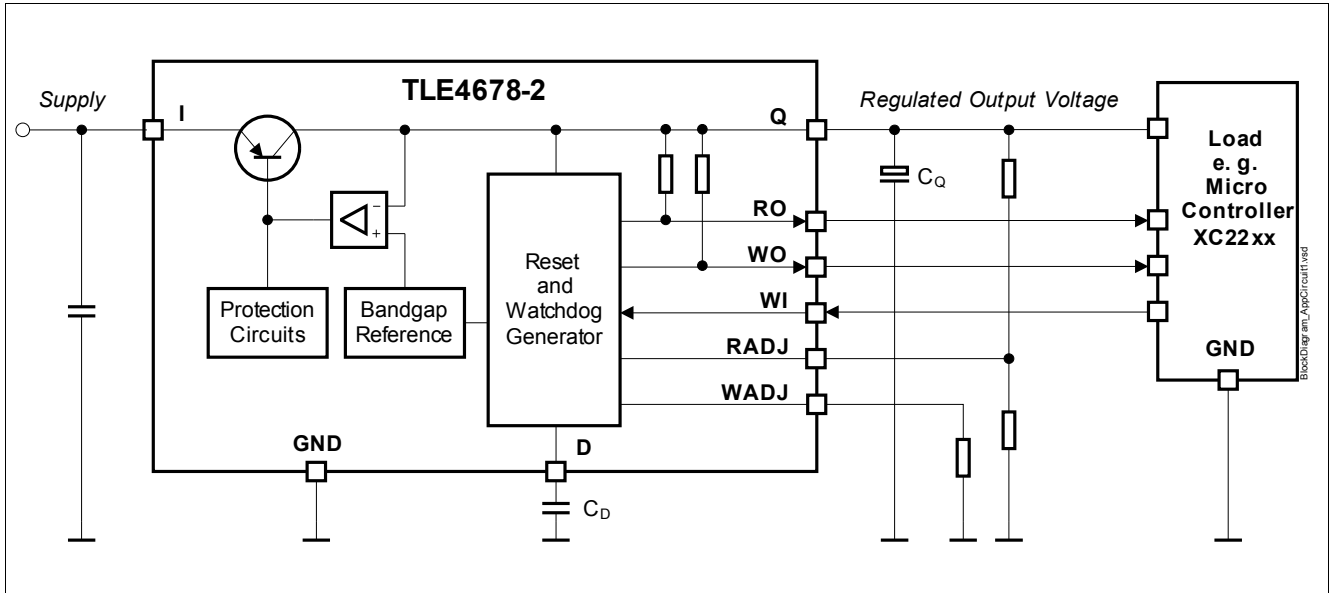

Figure 1 Block Diagram and Simplified Application Circuit

3 Pin Configuration

3.1 Pin Configuration PG-TSON10

3.1.1 Pin Assignment

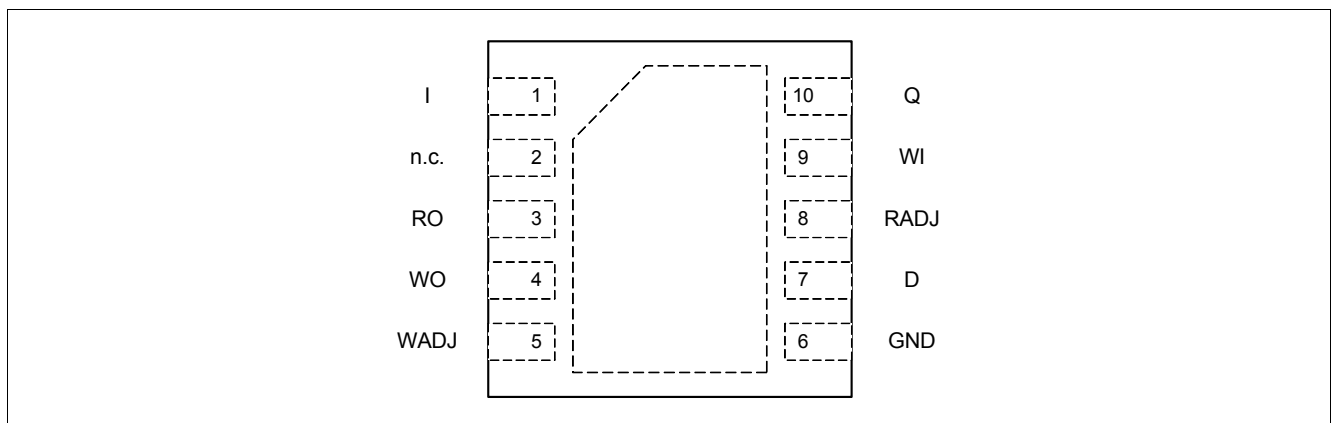

Figure 2 Pin Assignment Package

3.1.2 Pin Definitions and Functions PG-TSON10

Pin	Symbol	Function
1	I	Regulator Input and IC Supply For compensating line influences, a capacitor to GND close to the IC pins is recommended.
3	RO	Reset Output Open collector output with an internal pull-up resistor to the output Q. An additional external pull-up resistor to the output Q is optional. Leave open if the reset function is not needed.
4	WO	Watchdog Output Open collector output with an internal pull-up resistor to the output Q. An additional external pull-up resistor to the output Q is optional. Leave open if the watchdog function is not needed.
5	WADJ	Watchdog Activating Threshold Adjust An external resistor to GND determines the watchdog activating threshold. Connect directly to GND for disabling the watchdog. Connect directly to GND if the watchdog function is not needed. Connect to output Q via 270 kΩ resistor for permanently activating the watchdog.
6	GND	IC Ground Interconnect with the exposed pad and heatsink area on PCB.

Pin Configuration

Pin	Symbol	Function
7	D	<p>Reset Delay and Watchdog Timing Connect a ceramic capacitor D (pin 6) to GND for reset delay and watchdog timing adjustment. Leave only open if both, the reset and the watchdog function are not needed.</p>
8	RADJ	<p>Reset Switching Threshold Adjust For reset threshold adjustment connect to a voltage divider from output Q to GND. For triggering the reset at the internally determined threshold, connect this pin directly to GND. Connect directly to GND if the reset function is not needed.</p>
9	WI	<p>Watchdog Input Positive edge triggered input, usable for microcontroller monitoring. Connect to GND if the watchdog function is not needed.</p>
10	Q	<p>5 V Regulator Output Block to GND with a capacitor close to the IC pins, respecting capacitance and ESR requirements given in the Chapter 4.2.</p>
2	n. c.	<p>Internally not connected Connection to GND on PCB recommended.</p>
Exposed pad		<p>Connect to heat sink area on PCB. Interconnect with GND.</p>

4 General Product Characteristics

4.1 Absolute Maximum Ratings

Note: Stresses above the ones listed here may cause permanent damage to the device. Exposure to absolute maximum rating conditions for extended periods may affect device reliability.

1. Integrated protection functions are designed to prevent IC destruction under fault conditions described in the data sheet. Fault conditions are considered as “outside” normal operating range. Protection functions are not designed for continuous repetitive operation.

Table 1 Absolute Maximum Ratings¹⁾

$T_j = -40^\circ\text{C}$ to $+150^\circ\text{C}$; all voltages with respect to ground, positive current flowing into pin (unless otherwise specified)

Parameter	Symbol	Values			Unit	Note / Test Condition	Number
		Min.	Typ.	Max.			
Voltage Rating							
Regulator Input and IC Supply I	V_I	-14	–	45	V	–	P_4.1.1
Regulator Output Q	V_Q	-1	–	7	V	–	P_4.1.2
Reset Output RO	V_{RO}	-0.3	–	7	V	–	P_4.1.3
Reset Delay and Watchdog Timing D	V_D	-0.3	–	7	V	–	P_4.1.4
Reset Switching Threshold Adjust RADJ	V_{RADJ}	-0.3	–	7	V	–	P_4.1.5
Watchdog Input WI	V_{WI}	-0.3	–	7	V	–	P_4.1.6
Watchdog Output WO	V_{WO}	-0.3	–	7	V	–	P_4.1.7
Watchdog Activating Threshold Adjust WADJ	V_{WADJ}	-0.3	–	7	V	–	P_4.1.8
Temperature							
Junction Temperature	T_j	-40	–	150	$^\circ\text{C}$	–	P_4.1.9
Storage Temperature	T_{stg}	-55	–	150	$^\circ\text{C}$	–	P_4.1.10
ESD Susceptibility							
ESD Susceptibility	$V_{ESD,1}$	-3	–	3	kV	HBM ²⁾ ; Pin 1 (Input) only.	P_4.1.11
ESD Susceptibility	V_{ESD}	-2	–	2	kV	HBM ²⁾ All pins except pin 1 (Input)	P_4.1.12
ESD Susceptibility all pins	V_{ESD}	-1	–	1	kV	CDM ³⁾	P_4.1.13

1) Not subject to production test, specified by design.

2) ESD susceptibility, HBM according to ANSI/ESDA/JEDEC JS001 (1.5k Ω , 100 pF)

3) ESD susceptibility, Charged Device Model “CDM” according JEDEC JESD22-C101.

Note: Stresses above the ones listed here may cause permanent damage to the device. Exposure to absolute maximum rating conditions for extended periods may affect device reliability.

Integrated protection functions are designed to prevent IC destruction under fault conditions described in the data sheet. Fault conditions are considered as “outside” normal operating range. Protection functions are not designed for continuous repetitive operation.

4.2 Functional Range

Table 2 Functional Range

Parameter	Symbol	Values			Unit	Note / Test Condition	Number
		Min.	Typ.	Max.			
Input Voltage Range for Normal Operation	$V_{I(nor)}$	$V_Q + V_{dr}$	–	45	V	¹⁾	P_4.2.1
Extended Input Voltage Range	$V_{I(ext)}$	3.3	–	45	V	²⁾	P_4.2.2
Input Voltage Transient Immunity	dV_I/dt	-10	–	20	V/ μ s	$dV_I \leq 10$ V; $V_I > 9$ V; No trigger of WO, RO. ³⁾	P_4.2.3
Junction Temperature	T_j	-40	–	150	°C	–	P_4.2.4
Output Capacitor Requirements	C_Q	10	–	–	μ F	⁴⁾	P_4.2.5
Output Capacitor Requirements	ESR_{CQ}	–	–	3	Ω	⁵⁾	P_4.2.6

1) For specification of the output voltage V_Q and the drop out voltage V_{dr} , see [Chapter 5](#).

2) The output voltage V_Q will follow the input voltage, but is outside the specified range. For details see [Chapter 5](#).

3) Transient measured directly at the input pin. Not subject to production test, specified by design.

4) The minimum output capacitance requirement is applicable for a worst case capacitance tolerance of 30%.

5) Relevant ESR value at $f = 10$ kHz.

Note: Within the functional range the IC operates as described in the circuit description. The electrical characteristics are specified within the conditions given in the related electrical characteristics table.

4.3 Thermal Resistance

Note: This thermal data was generated in accordance with JEDEC JESD51 standards. For more information, go to www.jedec.org.

Table 3 Thermal Resistance

Parameter	Symbol	Values			Unit	Note / Test Condition	Number
		Min.	Typ.	Max.			
TLE4678-2LD (Package Versions PG-TSON10)							
Junction to Case ¹⁾	R_{thJC}	–	16	–	K/W	–	P_4.3.1
Junction to Ambient	R_{thJA}	–	190	–	K/W	footprint only ²⁾	P_4.3.2
Junction to Ambient	R_{thJA}	–	80	–	K/W	300 mm ² heatsink area on PCB ²⁾	P_4.3.3
Junction to Ambient	R_{thJA}	–	70	–	K/W	600 mm ² heatsink area on PCB ²⁾	P_4.3.4
Junction to Ambient	R_{thJA}	–	67	–	K/W	2s2p PCB ²⁾	P_4.3.5

1) Not subject to production test, specified by design

2) Specified R_{thJA} value is according to JEDEC JESD51-2,-5,-7 at natural convection on FR4 2s2p board; The Product (Chip+Package) was simulated on a 76.2 x 114.3 x 1.5 mm³ board with 2 inner copper layers (2 x 70 μ m Cu, 2 x 35 μ m Cu). Where applicable a thermal via array under the exposed pad contacted the first inner copper layer.

5 Voltage Regulator

5.1 Description Voltage Regulator

The output voltage V_Q is controlled by comparing a portion of it to an internal reference and driving a PNP pass transistor accordingly. Saturation control as a function of the load current prevents any oversaturation of the pass element. The control loop stability depends on the output capacitor C_Q , the load current, the chip temperature and the poles/zeros introduced by the integrated circuit. To ensure stable operation, the output capacitor's capacitance and its equivalent series resistor ESR requirements given in the chapter [Chapter 4.2](#) have to be maintained. For details see also the typical performance graph "Output Capacitor Series Resistor ESR_{CQ} vs. Output Current I_Q ". Also, the output capacitor shall be sized to buffer load transients.

An input capacitor C_I is not needed for the control loop stability, but recommended to buffer line influences. Connect the capacitors close to the IC terminals.

Protection circuitry prevent the IC as well as the application from destruction in case of catastrophic events. These safeguards contain output current limitation, reverse polarity protection as well as thermal shutdown in case of overtemperature.

In order to avoid excessive power dissipation that could never be handled by the pass element and the package, the maximum output current is decreased at input voltages above $V_I = 22\text{ V}$.

The thermal shutdown circuit prevents the IC from immediate destruction under fault conditions (e.g. output continuously short-circuited) by switching off the power stage. After the chip has cooled down, the regulator restarts. This leads to an oscillatory behavior of the output voltage until the fault is removed. However, a junction temperature above $150\text{ }^\circ\text{C}$ is outside the maximum rating and therefore reduces the IC lifetime.

The TLE4678-2 allows a negative supply voltage. However, several small currents are flowing into the IC increasing its junction temperature. This has to be considered for the thermal design, respecting that the thermal protection circuit is not operating during reverse polarity condition.

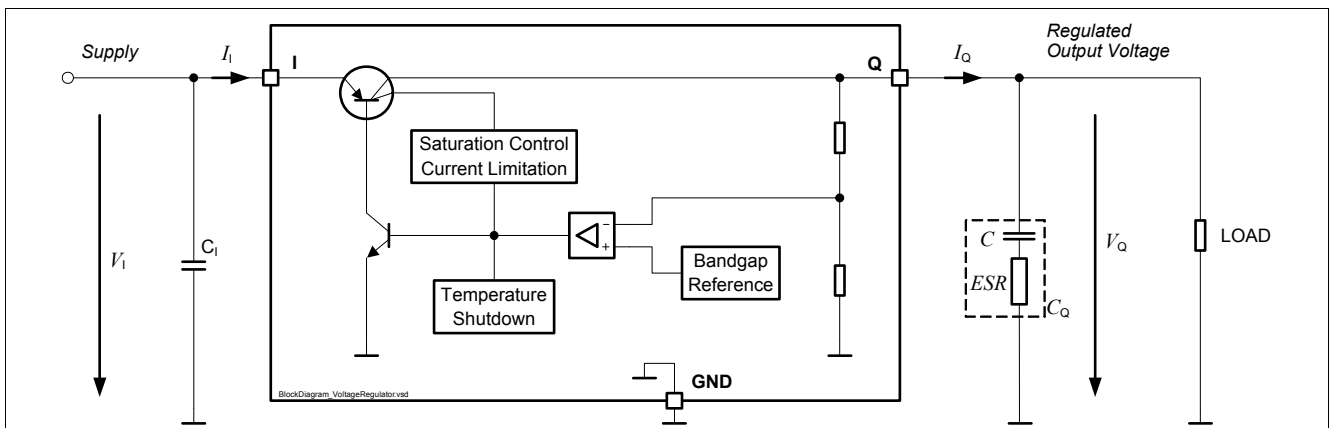

Figure 3 Block Diagram Voltage Regulator Circuit

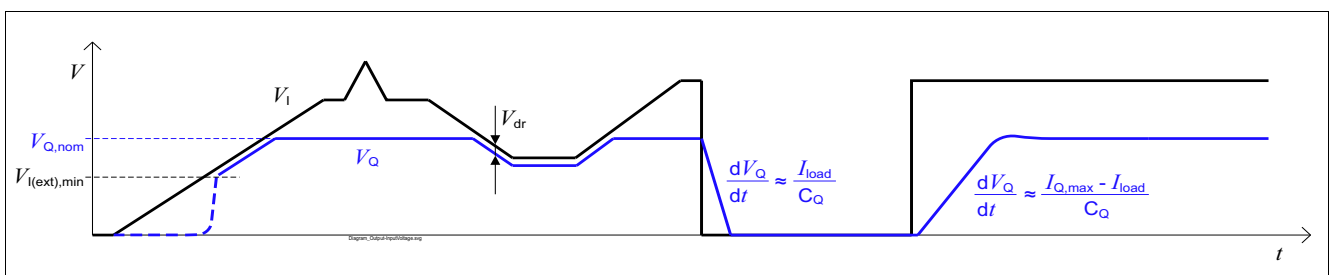

Figure 4 Output Voltage vs. Input Voltage

5.2 Electrical Characteristics Voltage Regulator

Table 4 Electrical Characteristics: Voltage Regulator
 $V_1 = 13.5 \text{ V}$, $T_j = -40^\circ\text{C}$ to $+150^\circ\text{C}$,

 all voltages with respect to ground, direction of currents as shown in **Figure 3** (unless otherwise specified)

Parameter	Symbol	Values			Unit	Note / Test Condition	Number
		Min.	Typ.	Max.			
Output Voltage	V_Q	4.9	5.0	5.1	V	$0 \text{ mA} \leq I_Q \leq 200 \text{ mA}$; $8 \text{ V} \leq V_1 \leq 18 \text{ V}$	P_5.2.1
Output Voltage	V_Q	4.9	5.0	5.1	V	$0 \text{ mA} \leq I_Q \leq 150 \text{ mA}$; $6 \text{ V} \leq V_1 \leq 18 \text{ V}$	P_5.2.2
Output Voltage	V_Q	4.9	5.0	5.1	V	$0 \text{ mA} \leq I_Q \leq 100 \text{ mA}$; $18 \text{ V} \leq V_1 \leq 32 \text{ V}$ $T_j \leq 105^\circ\text{C}$ ^{1) 2)}	P_5.2.3
Output Voltage	V_Q	4.9	5.0	5.1	V	$0 \text{ mA} \leq I_Q \leq 10 \text{ mA}$; $32 \text{ V} \leq V_1 \leq 45 \text{ V}$ $T_j \leq 105^\circ\text{C}$ ^{1) 2)}	P_5.2.4
Output Voltage	V_Q	4.9	5.0	5.1	V	$0.3 \text{ mA} \leq I_Q \leq 100 \text{ mA}$; $18 \text{ V} \leq V_1 \leq 32 \text{ V}$ ¹⁾	P_5.2.5
Output Voltage	V_Q	4.9	5.0	5.1	V	$0.3 \text{ mA} \leq I_Q \leq 10 \text{ mA}$; $32 \text{ V} \leq V_1 \leq 45 \text{ V}$ ¹⁾	P_5.2.6
Load Regulation steady-state	$ dV_{Q,\text{load}} $	–	5	30	mV	$I_Q = 1 \text{ mA}$ to 150 mA ; $V_1 = 6 \text{ V}$	P_5.2.7
Line Regulation steady-state	$ dV_{Q,\text{line}} $	–	5	20	mV	$V_1 = 6 \text{ V}$ to 32 V ; $I_Q = 5 \text{ mA}$	P_5.2.8
Power Supply Ripple Rejection	$PSRR$	60	65	–	dB	$f_{\text{ripple}} = 100 \text{ Hz}$; $V_{\text{ripple}} = 1 \text{ Vpp}$ ²⁾	P_5.2.9
Drop out Voltage $V_{\text{dr}} = V_1 - V_Q$	V_{dr}	–	80	170	mV	$I_Q = 50 \text{ mA}$ ³⁾	P_5.2.10
Drop out Voltage $V_{\text{dr}} = V_1 - V_Q$	V_{dr}	–	120	300	mV	$I_Q = 150 \text{ mA}$ ³⁾	P_5.2.11
Output Current Limitation	$I_{Q,\text{max}}$	201	350	500	mA	$0 \text{ V} \leq V_Q \leq 4.8 \text{ V}$	P_5.2.12
Reverse Current	I_Q	-1.5	-0.7	–	mA	$V_1 = 0 \text{ V}$; $V_Q = 5 \text{ V}$	P_5.2.13
Reverse Current at Negative Input Voltage	I_1	-2	-1	–	mA	$V_1 = -14 \text{ V}$; $V_Q = 0 \text{ V}$	P_5.2.14
Overtemperature Shutdown Threshold	$T_{j,\text{sd}}$	151	–	200	$^\circ\text{C}$	T_j increasing ²⁾	P_5.2.15
Overtemperature Shutdown Threshold Hysteresis	$T_{j,\text{hy}}$	–	20	–	K	T_j decreasing ²⁾	P_5.2.16

1) See typical performance graph for details.

2) Parameter not subject to production test; specified by design.

 3) Measured when the output voltage V_Q has dropped 100 mV from its nominal value.

5.3 Typical Performance Characteristics Voltage Regulator

Output Voltage V_Q versus Junction Temperature T_j

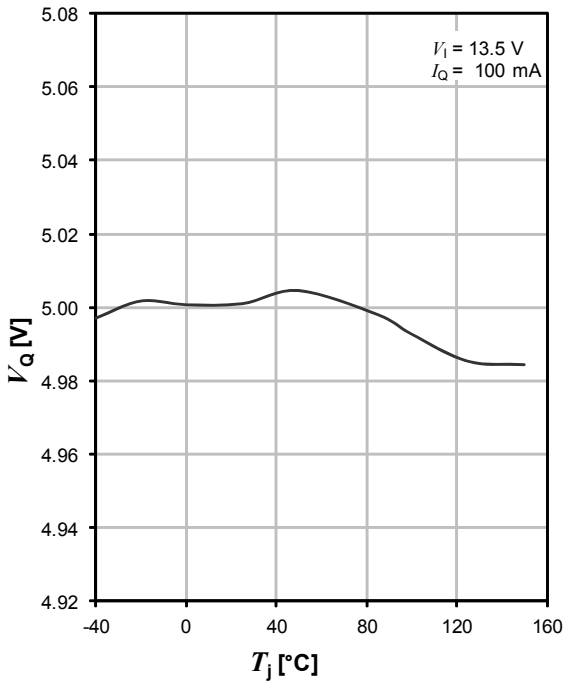

Output Current Limitation $I_{Q,max}$ versus Input Voltage V_I

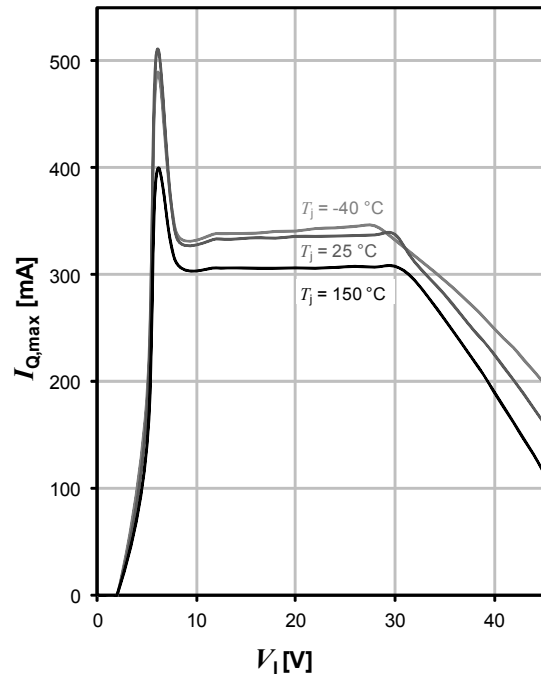

Dropout Voltage V_{dr} versus Junction Temperature T_j

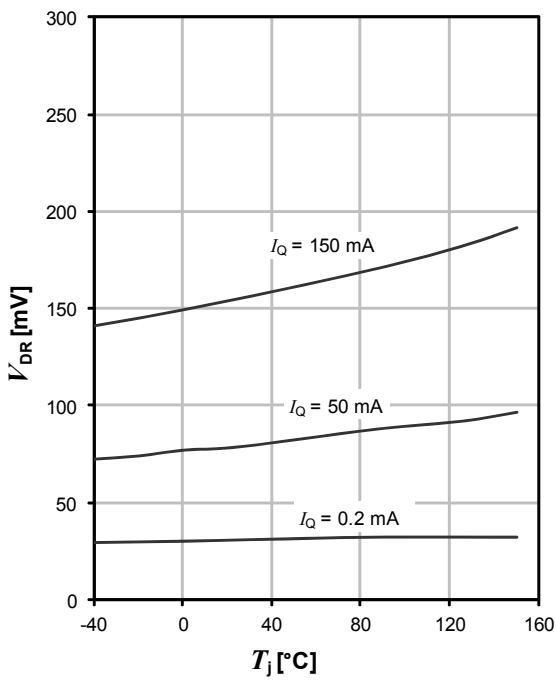

Dropout Voltage V_{dr} versus Output Current I_Q

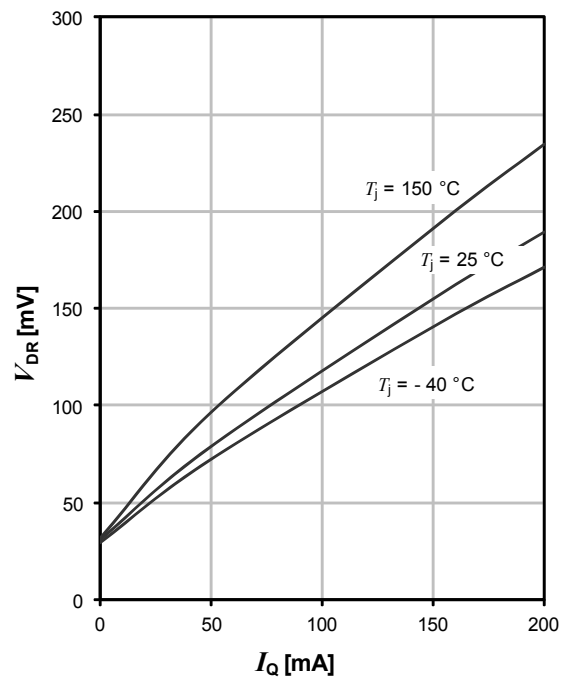

Reverse Output Current I_Q versus Output Voltage V_Q

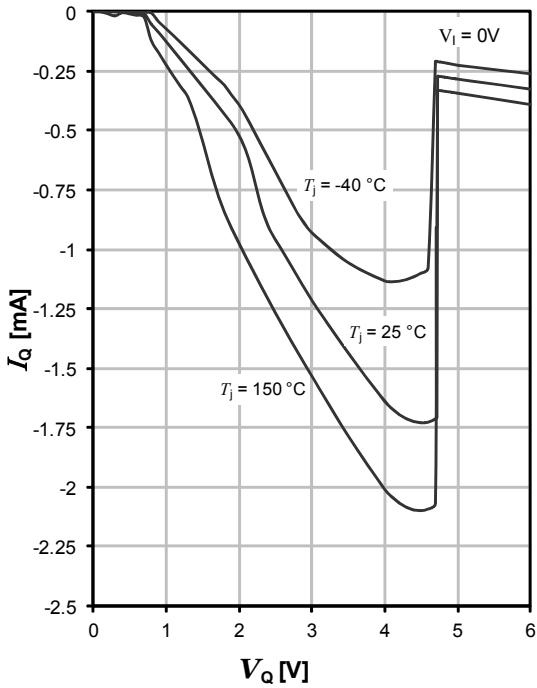

Output Capacitor Series Resistor ESR_{C_Q} versus Output Current I_Q

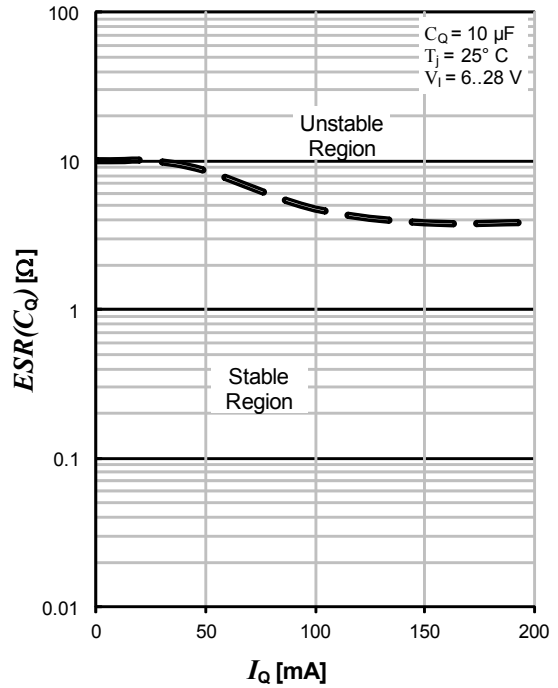

Reverse Current I_I versus Input Voltage V_I

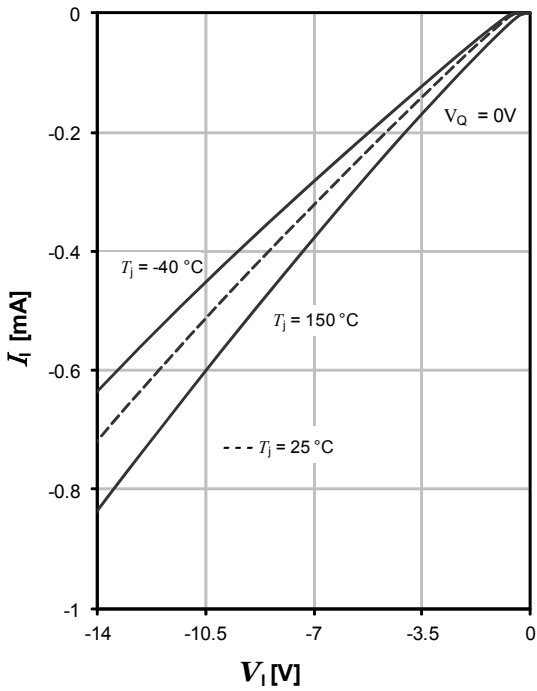

Power Supply Ripple Rejection $PSRR$ versus Frequency f

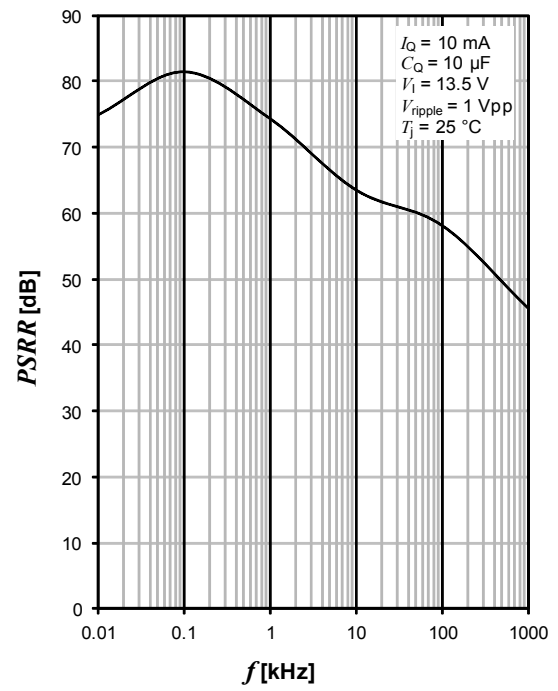

Output Voltage ΔV_Q versus Output Current I_Q

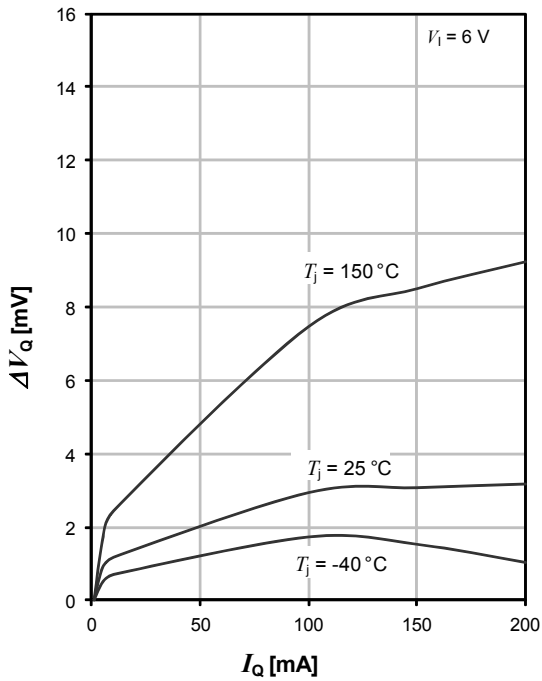

Load Transient Response

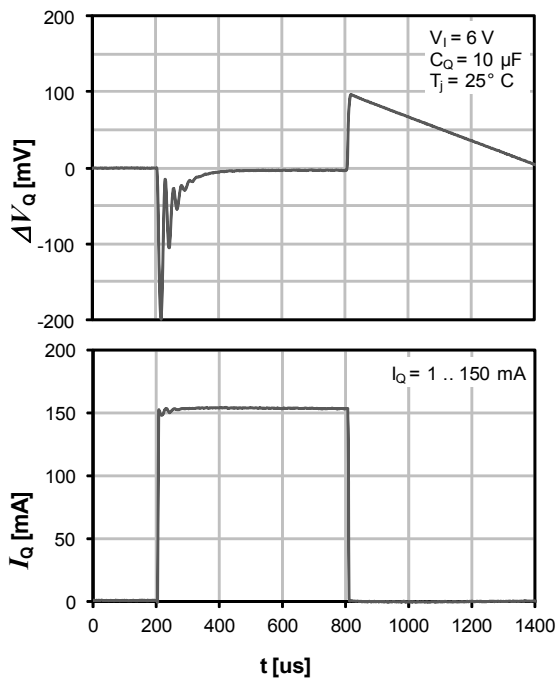

Output Voltage ΔV_Q versus Input Voltage V_1

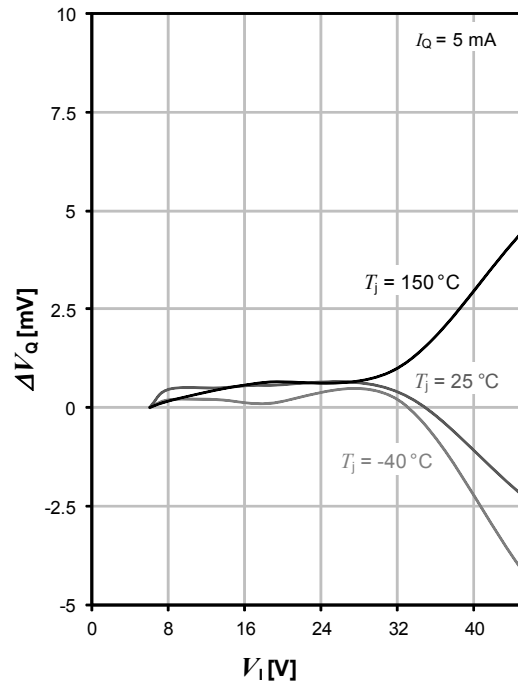

Line Transient Response

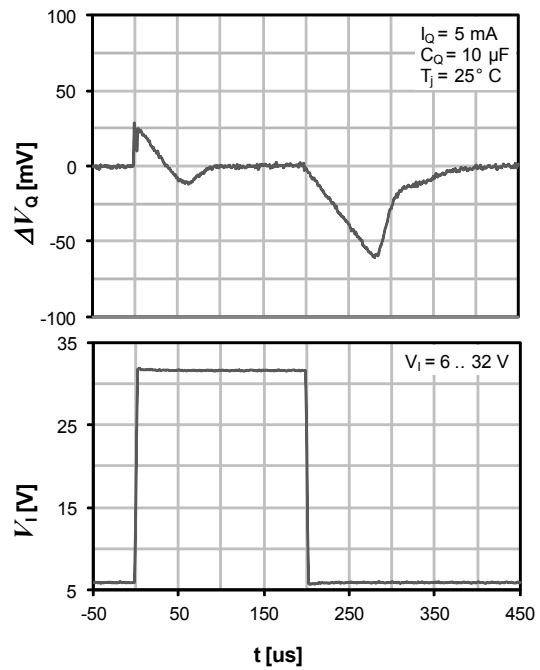

6 Current Consumption

6.1 Electrical Characteristics Current Consumption

Table 5 Electrical Characteristics: Current Consumption

$V_1 = 13.5\text{ V}$, $T_j = -40^\circ\text{C}$ to $+150^\circ\text{C}$,

all voltages with respect to ground, direction of currents as shown in **Figure 5** (unless otherwise specified).

Parameter	Symbol	Values			Unit	Note / Test Condition	Number
		Min.	Typ.	Max.			
Current Consumption Watchdog Deactivated $I_q = I_1 - I_Q$	I_{q1}	–	60	80	μA	$I_Q \leq 200\ \mu\text{A}$; $T_j \leq 25^\circ\text{C}$ Watchdog deactivated	P_6.1.1
Current Consumption Watchdog Deactivated $I_q = I_1 - I_Q$	I_{q1}	–	70	85	μA	$I_Q \leq 200\ \mu\text{A}$; $T_j \leq 85^\circ\text{C}$ Watchdog deactivated	P_6.1.2
Current Consumption $I_q = I_1 - I_Q$	I_{q2}	–	110	140	μA	$I_Q \leq 2\ \text{mA}$; $T_j \leq 25^\circ\text{C}$ Watchdog activated	P_6.1.3
Current Consumption $I_q = I_1 - I_Q$	I_{q2}	–	120	155	μA	$I_Q \leq 2\ \text{mA}$; $T_j \leq 85^\circ\text{C}$ Watchdog activated	P_6.1.4
Current Consumption $I_q = I_1 - I_Q$	I_{q2}	–	0.6	1.6	mA	$I_Q = 50\ \text{mA}$	P_6.1.5
Current Consumption $I_q = I_1 - I_Q$	I_{q2}	–	2	6	mA	$I_Q = 150\ \text{mA}$	P_6.1.6

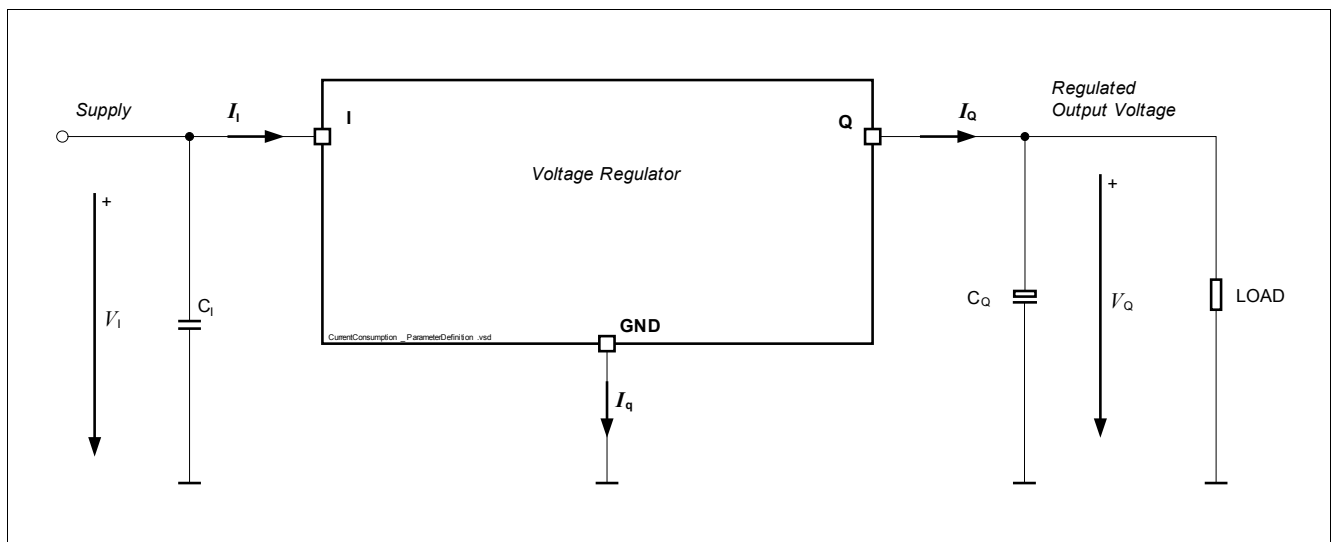
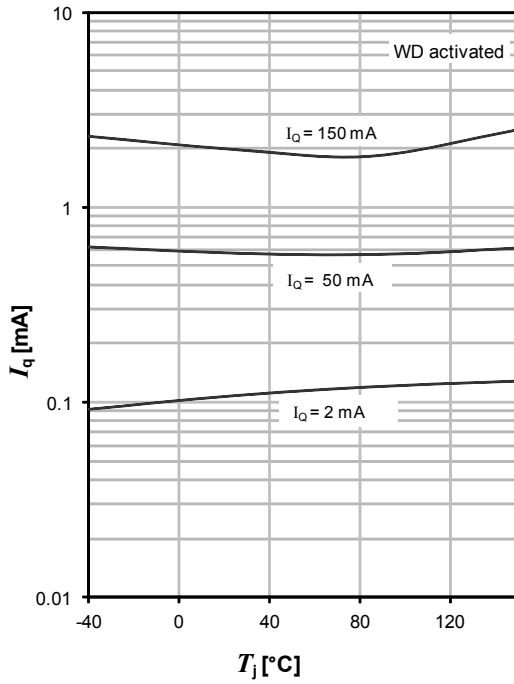

Figure 5 Parameter Definition

6.2 Typical Performance Characteristics Current Consumption

Current Consumption I_q versus Junction Temperature T_j



Current Consumption I_q versus Output Current I_Q

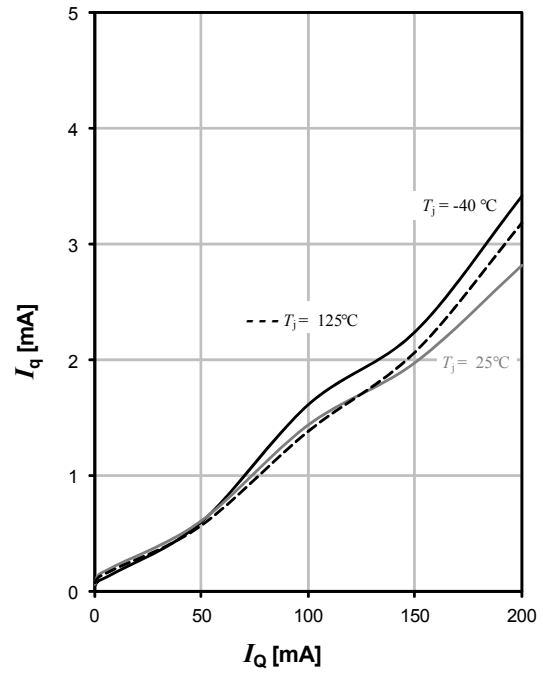

Current Consumption I_q versus Junction Temperature T_j

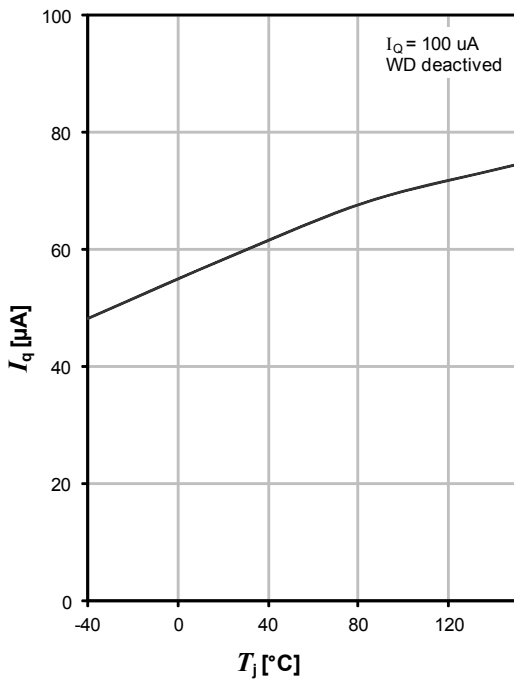

Current Consumption I_q versus Input Voltage V_I

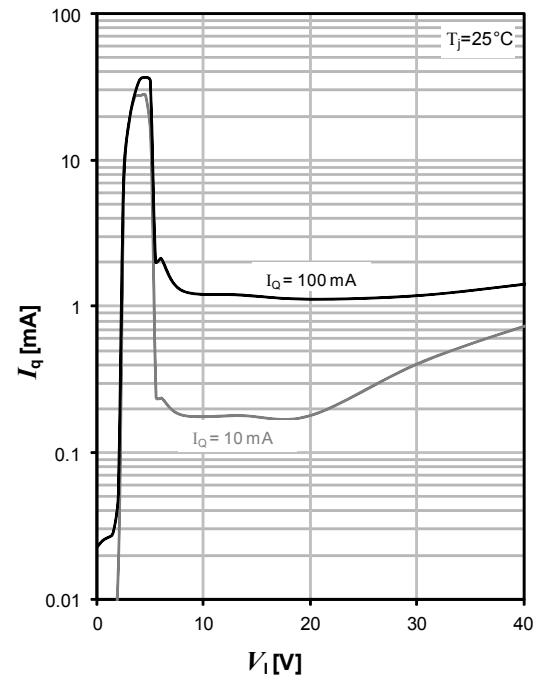

7 Reset Function

7.1 Description Reset Function

The reset function provides several features:

Output Undervoltage Reset:

An output undervoltage condition is indicated by setting the Reset Output "RO" to "low". This signal might be used to reset a microcontroller during low supply voltage.

Power-On Reset Delay Time

The power-on reset delay time $t_{d,PWR-ON}$ allows a microcontroller and oscillator to start up. This delay time is the time period from exceeding the upper reset switching threshold $V_{RT,hi}$ until the reset is released by switching the reset output "RO" from "low" to "high". The power-on reset delay time $t_{d,PWR-ON}$ is defined by an external delay capacitor C_D connected to pin "D" which is charged up by the delay capacitor charge current $I_{D,ch}$ starting from $V_D = 0$ V.

In case a power-on reset delay time $t_{d,PWR-ON}$ different from the value for $C_D = 100$ nF is required, the delay capacitor's value can be derived from the specified value given in [Table "Power-on Reset Delay Time" on Page 20](#):

$$C_D = 100\text{nF} \times t_{d,PWR-ON} / t_{d,PWR-ON,100\text{nF}} \quad (1)$$

with

- $t_{d,PWR-ON}$: Desired power-on reset delay time
- $t_{d,PWR-ON,100\text{nF}}$: Power-on reset delay time specified in [Table "Power-on Reset Delay Time" on Page 20](#)
- C_D : Delay capacitor required.

The formula is valid for $C_D \geq 10$ nF. For precise timing calculations consider also the delay capacitor's tolerance.

Undervoltage Reset Delay Time

Unlike the power-on reset delay time, the undervoltage reset delay time t_d considers a short output undervoltage event where the delay capacitor C_D is assumed to be discharged to $V_D = V_{DST,lo}$ only before the charging sequence starts. Therefore, the undervoltage reset delay time t_d is defined by the delay capacitor charge current $I_{D,ch}$ starting from $V_D = V_{DST,lo}$ and the external delay capacitor C_D .

A delay capacitor C_D for a different undervoltage reset delay time as specified in [Table "Undervoltage Reset Delay Time" on Page 19](#) can be calculated similar as above:

$$C_D = 100\text{nF} \times t_d / t_{d,100\text{nF}} \quad (2)$$

with:

- t_d : Desired undervoltage reset delay time
- $t_{d,100\text{nF}}$: Power-on reset delay time specified in [Table "Undervoltage Reset Delay Time" on Page 19](#)
- C_D : Delay capacitor required

The formula is valid for $C_D \geq 10$ nF. For precise timing calculations consider also the delay capacitor's tolerance.

Reset Reaction Time

In case the output voltage of the regulator drops below the output undervoltage lower reset threshold $V_{RT,lo}$, the delay capacitor C_D is discharged rapidly. Once the delay capacitor's voltage has reached the lower delay switching threshold $V_{DST,lo}$, the reset output "RO" will be set to "low". In case of a very short drop of output voltage, may the delay capacitor voltage doesn't reach the lower delay switching threshold and therefore no "RO" = "low" will be set. This prevents a microcontroller reset because of a very short distortion on output voltage. Typically the time of this filter effect is about 550 ns ($t_{rr,blank}$). See also timing diagram on [Page 18](#)

Additionally to the delay capacitor discharge time $t_{rr,d}$, an internal reaction time $t_{rr,int}$ applies. Hence, the total reset reaction time $t_{rr,total}$ becomes:

$$t_{rr,total} = t_{rr,int} + t_{rr,d} \quad (3)$$

with

- $t_{rr,total}$: Total reset reaction time
- $t_{rr,int}$: Internal reset reaction time; see [Table "Internal Reset Reaction Time" on Page 20](#).
- $t_{rr,d}$: Delay capacitor discharge time. For a capacitor C_D different from the value specified in [Table "Delay Capacitor Discharge Time" on Page 20](#), see typical performance graphs.

Reset Output "RO"

The reset output "RO" is an open collector output with an integrated pull-up resistor. In case a lower-ohmic "RO" signal is desired, an external pull-up resistor to the output "Q" can be connected. Since the maximum "RO" sink current is limited, the optional external resistor $R_{RO,ext}$ must not be below as specified in [Table "Reset Output" on Page 19](#).

Reset Output "RO" Low for $V_Q \geq 1$ V

In case of an undervoltage reset condition reset output "RO" is held "low" for $V_Q \geq 1$ V, even if the input voltage V_I is 0 V. This is achieved by supplying the reset circuit from the output capacitor.

Reset Adjust Function

The undervoltage reset switching threshold can be adjusted according to the application's needs by connecting an external voltage divider ($R_{ADJ,1}$, $R_{ADJ,2}$) at pin "RADJ". For selecting the default threshold connect pin "RADJ" to GND. The reset adjustment range is given in [Table "Reset Adjustment Range" on Page 19](#).

When dimensioning the voltage divider, take into consideration that there will be an additional current constantly flowing through the resistors.

With a voltage divider connected, the reset switching threshold $V_{RT,new}$ is calculated as follows (neglecting the Reset Adjust Pin Current I_{RADJ}):

$$V_{RT,new} = V_{RADJ,th} \times (R_{ADJ,1} + R_{ADJ,2}) / R_{ADJ,2} \quad (4)$$

with

- $V_{RT,new}$: Desired reset switching threshold.
- $R_{ADJ,1}$, $R_{ADJ,2}$: Resistors of the external voltage divider, see [Figure 6](#).
- $V_{RADJ,th}$: Reset adjust switching threshold given in [Table "Reset Adjust" on Page 19](#).

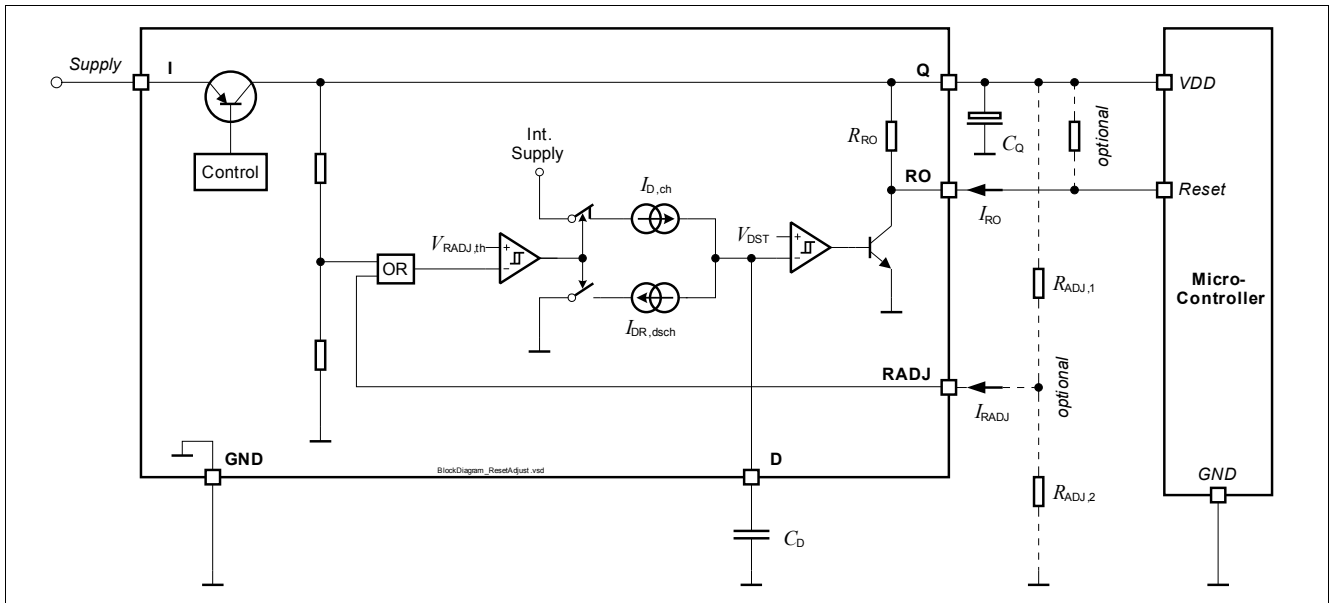

Figure 6 Block Diagram Reset Circuit

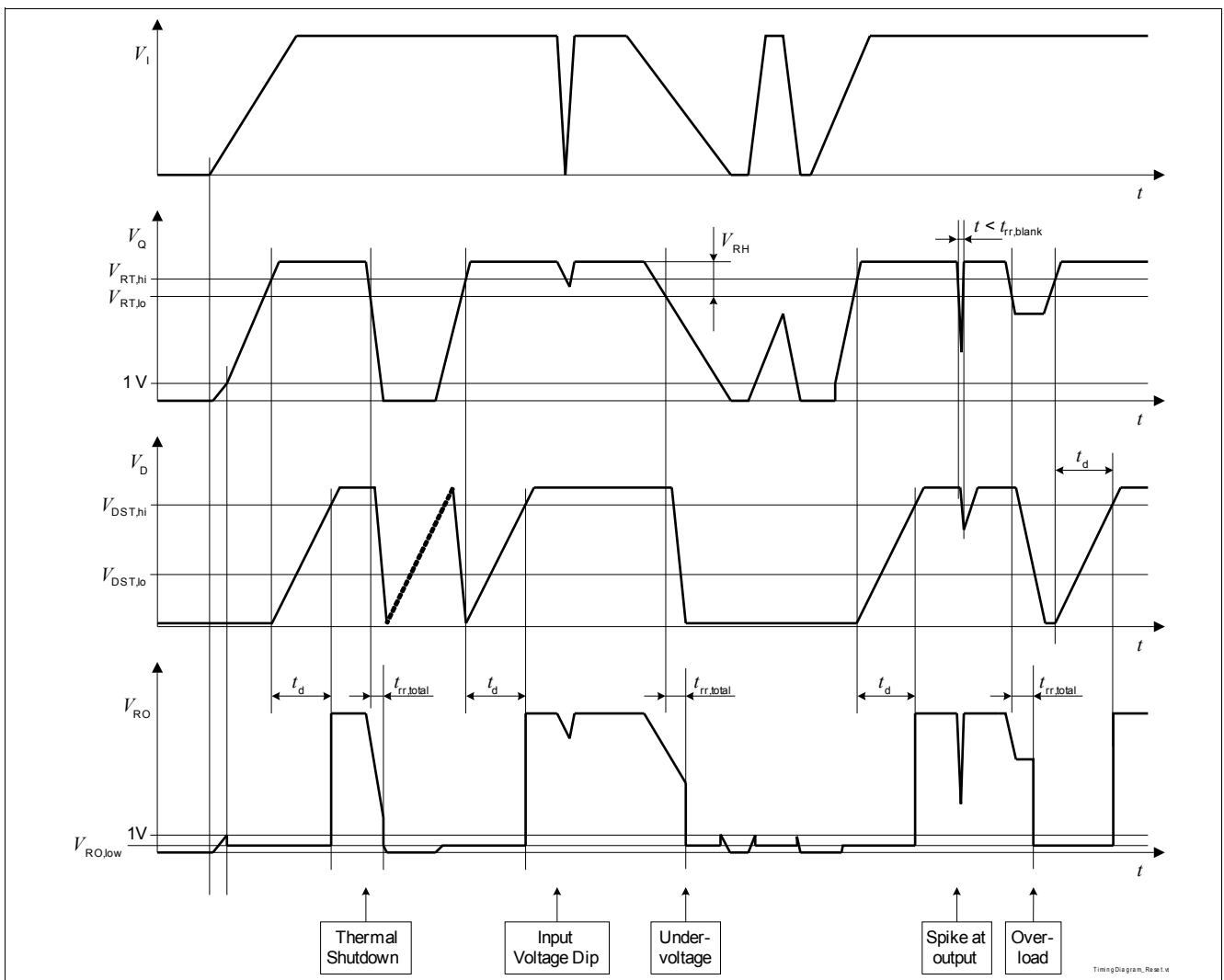

Figure 7 Timing Diagram Reset

7.2 Electrical Characteristics Reset Function

Table 6 Electrical Characteristics: Reset Function
 $V_I = 13.5 \text{ V}$, $T_j = -40^\circ\text{C}$ to $+150^\circ\text{C}$,

all voltages with respect to ground, direction of currents as shown in [Figure 6](#) (unless otherwise specified).

Parameter	Symbol	Values			Unit	Note / Test Condition	Number
		Min.	Typ.	Max.			
Output Undervoltage Reset Comparator Default Values (Pin RADJ = GND)							
Output Undervoltage Reset Lower Switching Threshold	$V_{RT,lo}$	4.6	4.7	4.8	V	$V_I = 0 \text{ V}$ V_Q decreasing RADJ = GND	P_7.2.1
Output Undervoltage Reset Upper Switching Threshold	$V_{RT,hi}$	4.7	4.8	4.9	V	V_I within operating range V_Q increasing RADJ = GND	P_7.2.2
Output Undervoltage Reset Switching Hysteresis	$V_{RT,hy}$	60	120	–	mV	V_I within operating range RADJ = GND.	P_7.2.3
Output Undervoltage Reset Headroom	V_{RH}	250	300	–	mV	Calculated Value: $V_Q - V_{RT,lo}$ V_I within operating range $I_Q = 50 \text{ mA}$ RADJ = GND	P_7.2.4
Reset Threshold Adjustment							
Reset Adjust Lower Switching Threshold	$V_{RADJ,th}$	1.176	1.20	1.224	V	$V_I = 0 \text{ V}$ $3.2 \text{ V} \leq V_Q < 4.6 \text{ V}$	P_7.2.5
Reset Adjustment Range ¹⁾	$V_{RT,range}$	3.20	–	4.60	V	–	P_7.2.6
Reset Output RO							
Reset Output Low Voltage	$V_{RO,low}$	–	0.2	0.4	V	$V_I = 0 \text{ V}$; $1 \text{ V} \leq V_Q \leq V_{RT,low}$ $R_{RO,ext} = 3.3 \text{ k}\Omega$	P_7.2.8
Reset Output External Pull-up Resistor to Q	$R_{RO,ext}$	3	–	–	k Ω	$V_I = 0 \text{ V}$; $1 \text{ V} \leq V_Q \leq V_{RT,low}$ $V_{RO} = 0.4 \text{ V}$	P_7.2.9
Reset Output Internal Pull-up Resistor	R_{RO}	20	30	45	k Ω	internally connected to Q	P_7.2.10
Reset Delay Timing							
Upper Delay Switching Threshold	$V_{DST,hi}$	–	1.21	–	V	–	P_7.2.11
Lower Delay Switching Threshold	$V_{DST,lo}$	–	0.30	–	V	–	P_7.2.12
Delay Capacitor Charge Current	$I_{D,ch}$	–	2.8	–	μA	$V_D = 1 \text{ V}$	P_7.2.13
Delay Capacitor Reset Discharge Current	$I_{DR,dsch}$	–	80	–	mA	$V_D = 1 \text{ V}$	P_7.2.14
Undervoltage Reset Delay Time	$t_{d,100nF}$	20	31	45	ms	Calculated value; $C_D = 100 \text{ nF}$ ²⁾ ; C_D discharged to $V_{DST,lo}$	P_7.2.15

Table 6 Electrical Characteristics: Reset Function (cont'd)

$V_1 = 13.5\text{ V}$, $T_j = -40^\circ\text{C}$ to $+150^\circ\text{C}$,

all voltages with respect to ground, direction of currents as shown in [Figure 6](#) (unless otherwise specified).

Parameter	Symbol	Values			Unit	Note / Test Condition	Number
		Min.	Typ.	Max.			
Power-on Reset Delay Time	$t_{d,PWR-ON,100nF}$	28	43	64	ms	Calculated value; $C_D = 100\text{ nF}^{2)}$; C_D discharged to 0 V;	P_7.2.16
Internal Reset Reaction Time	$t_{rr,int}$	–	9	15	μs	$C_D = 0\text{ nF}$	P_7.2.17
Delay Capacitor Discharge Time	$t_{rr,d,100nF}$	–	1.5	3	μs	$C_D = 100\text{ nF}^{2)}$	P_7.2.18
Total Reset Reaction Time	$t_{rr,total,100nF}$	–	10.5	18	μs	Calculated Value: $t_{rr,d,100nF} + t_{rr,int}$; $C_D = 100\text{ nF}^{2)}$	P_7.2.19

1) Related Parameters ($V_{RT,hi}$, $V_{RT,hy}$) are scaled linear when the Reset Switching Threshold is modified.

2) For programming a different delay and reset reaction time, see [Chapter 7.1](#).

7.3 Typical Performance Characteristics Reset Function

Undervoltage Reset Switching Thresholds
 $V_{RT,LOW}$, $V_{RT,HIGH}$ versus Junction Temperature T_j

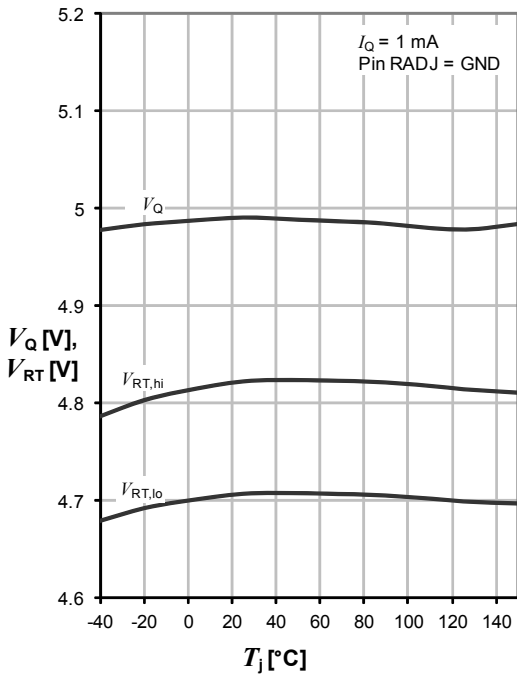

Reset Delay Time t_d , $t_{d,PWR-ON}$ versus Delay Capacitor C_D

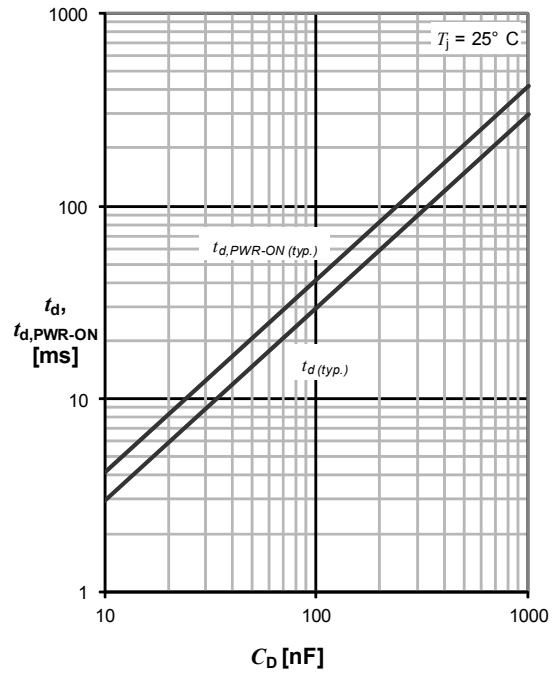

8 Watchdog Function

8.1 Description

The TLE4678-2 features a load dependent watchdog function with a programmable activating threshold as well as a programmable watchdog timing.

The watchdog function monitors a microcontroller, including time base failures. In case of a missing rising edge within a certain pulse repetition time, the watchdog output is set to 'low'. The programming of the expected watchdog pulse repetition time can be easily done by an external reset delay capacitor.

The watchdog output "WO" is separated from the reset output "RO". Hence, the watchdog output might be used as an interrupt signal for the microcontroller independent from the reset signal. It is possible to interconnect pin "WO" and pin "RO" in order to establish a wire-or function with a dominant low signal.

Programmable Watchdog Activation Threshold and Hysteresis

In case a microcontroller is set to sleep mode or to low power mode, its current consumption is very low and the controller might not be able to send any watchdog pulses to the regulators watchdog input "WI". In order to avoid unwanted wake-up signals due to missing edges at pin "WI", the TLE4678-2 watchdog function can be activated dependent on the regulator's output current. The TLE4678-2 comprises a default watchdog activating threshold $I_{Q,WDact,th}$ with a small hysteresis $I_{Q,WDact,hy}$ which is modifiable by an external resistor $R_{WADJ,ext}$ connected to the pin "WADJ". For using the default watchdog activating threshold, leave pin "WADJ" open.

The following table shows the external resistor $R_{WADJ,ext}$ that is needed at pin "WADJ" for activating/deactivating the watchdog at a desired output current $I_{Q,WDact,th}$, $I_{Q,WDdeact,th}$.

Table 7

$R_{WADJ,ext}$ [kOhm]	$I_{Q,WDact,th}$ [mA]	$I_{Q,WDdeact,th}$ [mA]	$I_{Q,WDact,hy}$ [μ A]
4000	1.015	0.987	28
470	1.339	1.310	29
220	1.761	1.700	61
100	2.728	2.612	116
50	4.435	4.217	219
33	6.333	6.016	318
20	9.792	9.310	482
10	18.523	17.838	685
7.5	24.198	23.472	725

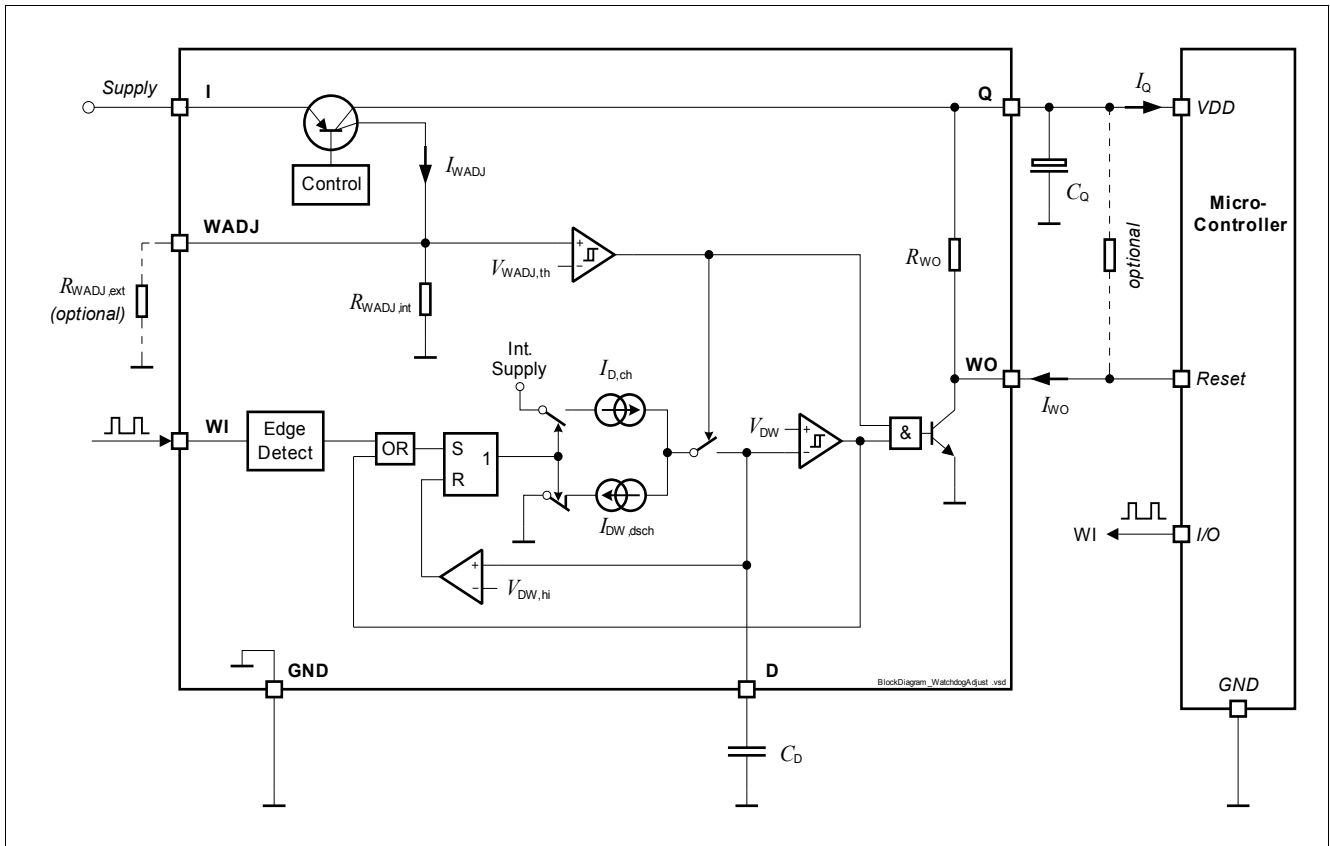

Figure 8 Block Diagram Watchdog Circuit

Watchdog Output “WO”

The watchdog output “WO” is an open collector output with an integrated pull-up resistor. In case a lower-ohmic “WO” signal is desired, an external pull-up resistor to the output “Q” can be connected. Since the maximum “WO” sink current is limited, the optional external resistor $R_{WO,ext}$ needs to be sized to comply with the watchdog output sink current (see [Table “Watchdog Output Low Voltage” on Page 25](#) and [Table “Watchdog Output Maximum Sink Current” on Page 25](#)).

Watchdog Input “WI”

The watchdog is triggered by an positive edge at the watchdog input “WI”. The signal is filtered by a bandpass filter and therefore its amplitude and slope has to comply with the specification [Table “Watchdog Input” on Page 25](#) to [Table “Watchdog Input Signal Slew Rate” on Page 25](#). For details on the test pulse applied, see [Figure 9](#).

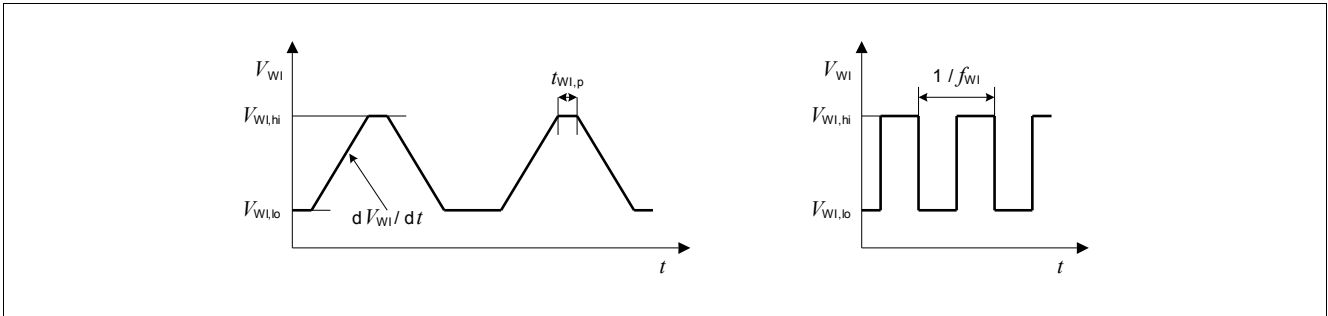

Figure 9 Test Pulses Watchdog Input WI

Watchdog Timing

Positive edges at the watchdog input pin “WI” are expected within the watchdog trigger time frame $t_{WI,tr}$, otherwise a low signal at pin “WO” is generated. If a watchdog low signal at pin “WO” is generated, it remains low for $t_{WD,lo}$. All watchdog timings are defined by charging and discharging the capacitor C_D at pin “D”. Thus, the watchdog timing can be programmed by selecting C_D . For timing details see also [Figure 10](#).

In case a watchdog trigger time period $t_{WI,tr}$ different from the value for $C_D = 100\text{nF}$ is required, the delay capacitor’s value can be derived from the specified value given in [Table “Watchdog Trigger Time” on Page 26](#):

$$C_D = 100\text{nF} \times t_{WI,tr} / t_{WI,tr,100\text{nF}} \tag{5}$$

The watchdog output low time $t_{WD,lo}$ and the watchdog period $t_{WD,p}$ then becomes:

$$t_{WD,lo} = t_{WD,lo,100\text{nF}} \times C_D / 100\text{nF} \tag{6}$$

$$t_{WD,p} = t_{WI,tr} + t_{WD,lo} \tag{7}$$

The formula is valid for $C_D \geq 10\text{nF}$. For precise timing calculations consider also the delay capacitor’s tolerance.

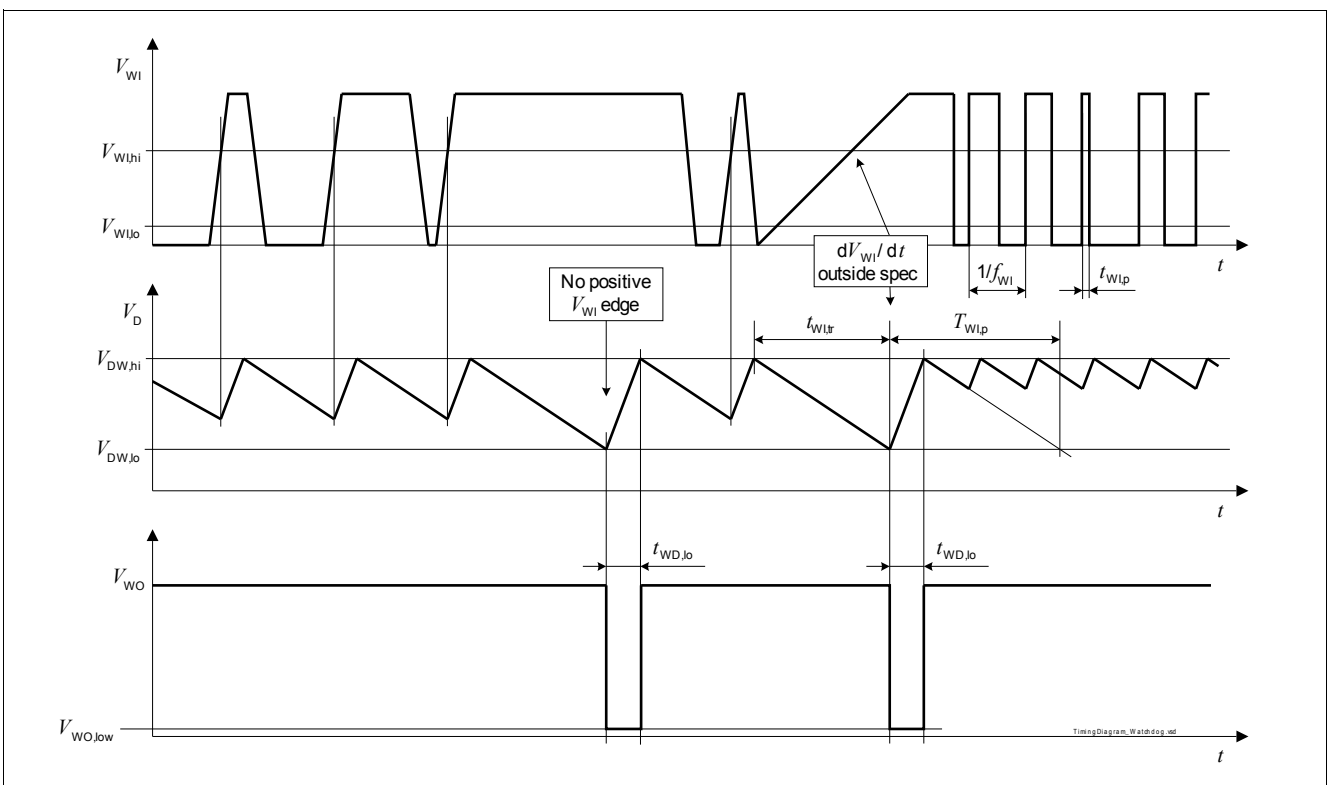

Figure 10 Timing Diagram Watchdog

8.2 Electrical Characteristics Watchdog Function

Table 8 Electrical Characteristics: Watchdog Function
 $V_1 = 13.5 \text{ V}$, $T_j = -40^\circ\text{C}$ to $+150^\circ\text{C}$,

all voltages with respect to ground, direction of currents as shown in [Table 8](#) (unless otherwise specified).

Parameter	Symbol	Values			Unit	Note / Test Condition	Number
		Min.	Typ.	Max.			
Default Watchdog Activating Threshold (pin WADJ left open)							
Watchdog Activating Threshold	$I_{Q,WDact,th}$	0.65	1.1	1.65	mA	I_Q increasing	P_8.2.1
Watchdog Deactivating Threshold	$I_{Q,WDdeact,th}$	0.55	0.9	–	mA	I_Q decreasing	P_8.2.2
Watchdog Activating Threshold Hysteresis	$I_{Q,WDact,hy}$	–	26	–	μA	–	P_8.2.3
Adjustable Watchdog Activating Threshold (external resistor connected to pin WADJ)							
Watchdog Activating Threshold	$I_{Q,WDact,th}$	–	1.76	–	mA	I_Q increasing $R_{WADJ,ext} = 220 \text{ k}\Omega^{1) 2)}$	P_8.2.4
Watchdog Deactivating Threshold	$I_{Q,WDdeact,th}$	–	1.70	–	mA	I_Q decreasing $R_{WADJ,ext} = 220 \text{ k}\Omega^{1) 2)}$	P_8.2.5
Watchdog Activating Threshold Hysteresis	$I_{Q,WDact,hy}$	–	60	–	μA	$R_{WADJ,ext} = 220 \text{ k}\Omega^{1) 2)}$	P_8.2.6
Watchdog Input WI							
Watchdog Input Low Signal Valid	$V_{WI,lo}$	–	–	0.8	V	– ³⁾	P_8.2.7
Watchdog Input High Signal Valid	$V_{WI,hi}$	2.6	–	–	V	– ³⁾	P_8.2.8
Watchdog Input High Signal Pulse Length	$t_{WI,p}$	0.5	–	–	μs	$V_{WI} \geq V_{WI,high}^{3)}$	P_8.2.9
Watchdog Input Signal Slew Rate	dV_{WI}/dt	1	–	–	V/ μs	$V_{WI,low} \leq V_{WI} \leq V_{WI,high}^{3)}$	P_8.2.10
Watchdog Input Signal Frequency Capture Range	f_{WI}	–	–	1	MHz	Square Wave, 50% Duty Cycle ³⁾	P_8.2.11
Watchdog Output WO							
Watchdog Output Low Voltage	$V_{WO,low}$	–	0.2	0.4	V	$I_{WO} = 1 \text{ mA}$; Watchdog active; $V_{WI} = 0 \text{ V}$	P_8.2.12
Watchdog Output Maximum Sink Current	$I_{WO,max}$	1.5	13	30	mA	$V_{WO} = 0.8 \text{ V}$; Watchdog active; $V_{WI} = 0 \text{ V}$	P_8.2.13
Watchdog Output Internal Pull-up Resistor	R_{WO}	20	30	45	k Ω	–	P_8.2.14
Watchdog Timing							
Delay Capacitor Charge Current	I_D	–	2.78	–	μA	$V_D = 1 \text{ V}$	P_8.2.15
Delay capacitor watchdog discharge current	$I_{DW,disch}$	–	1.39	–	μA	$V_D = 1 \text{ V}$	P_8.2.16

Table 8 Electrical Characteristics: Watchdog Function (cont'd)

$V_1 = 13.5\text{ V}$, $T_j = -40^\circ\text{C}$ to $+150^\circ\text{C}$,

all voltages with respect to ground, direction of currents as shown in [Table 8](#) (unless otherwise specified).

Parameter	Symbol	Values			Unit	Note / Test Condition	Number
		Min.	Typ.	Max.			
Upper watchdog timing threshold	$V_{DW,hi}$	–	1.2	–	V	–	P_8.2.17
Lower watchdog timing threshold	$V_{DW,lo}$	–	0.7	–	V	–	P_8.2.18
Watchdog Trigger Time	$t_{WI,tr,100nF}$	24	36	54	ms	Calculated value; $C_D = 100\text{ nF}$ ⁴⁾	P_8.2.19
Watchdog Output Low Time	$t_{WD,lo,100nF}$	12	18	27	ms	Calculated value; $C_D = 100\text{ nF}$ ⁴⁾ $V_Q > V_{RT,lo}$	P_8.2.20
Watchdog Period	$t_{WD,p,100nF}$	36	54	81	ms	Calculated value; $t_{WI,tr,100nF} + t_{WD,lo,100nF}$ $C_D = 100\text{ nF}$ ⁴⁾	P_8.2.21

- 1) For details see Table 7.
- 2) Not subject to production test, specified by design.
- 3) For details on the test pulse applied, see [Figure 9](#).
- 4) For programming a different watchdog timing, see [Chapter 8.1](#)..

8.3 Typical Performance Characteristics Standard Watchdog Function

Watchdog Activating Threshold $I_{Q,WDact,th}$ versus External Resistor $R_{WADJ,ext}$

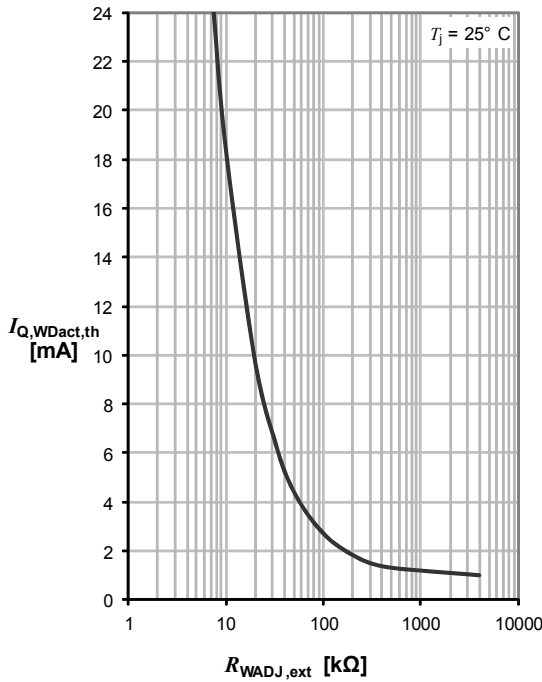

Watchdog Deactivating Threshold $I_{Q,WDdeact,th}$ versus External Resistor $R_{WADJ,ext}$

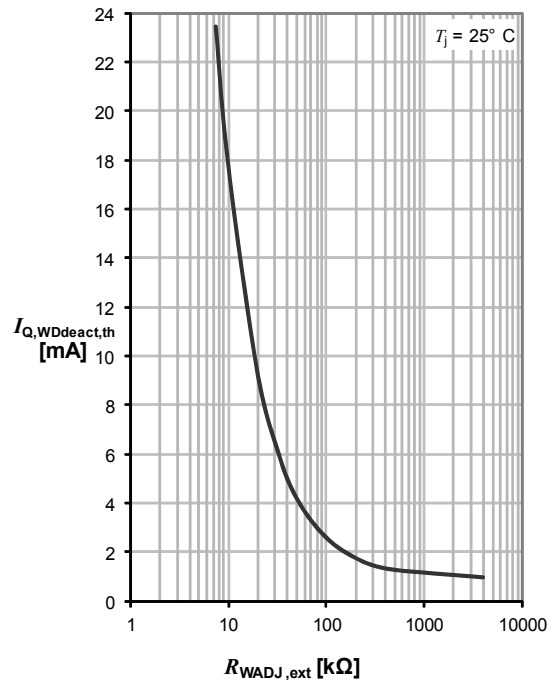

Watchdog Trigger Time $t_{WI,tr}$ versus Delay Capacitor C_D

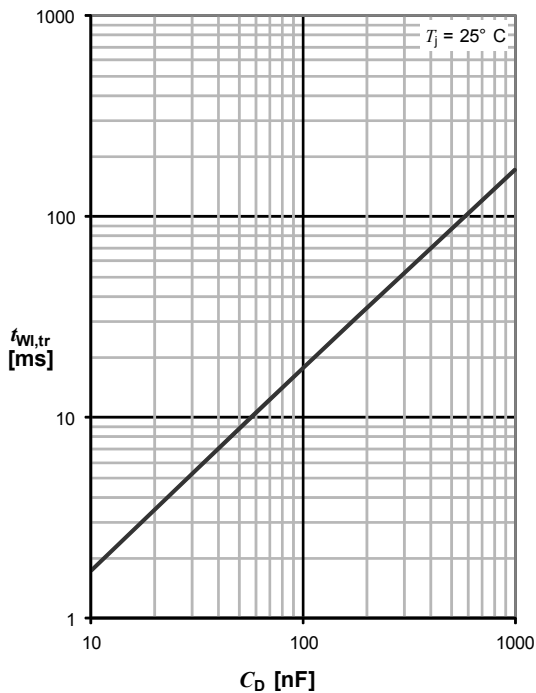

Watchdog Activation Threshold Hysteresis $I_{Q,WDact,hy}$ versus External Resistor $R_{WADJ,ext}$

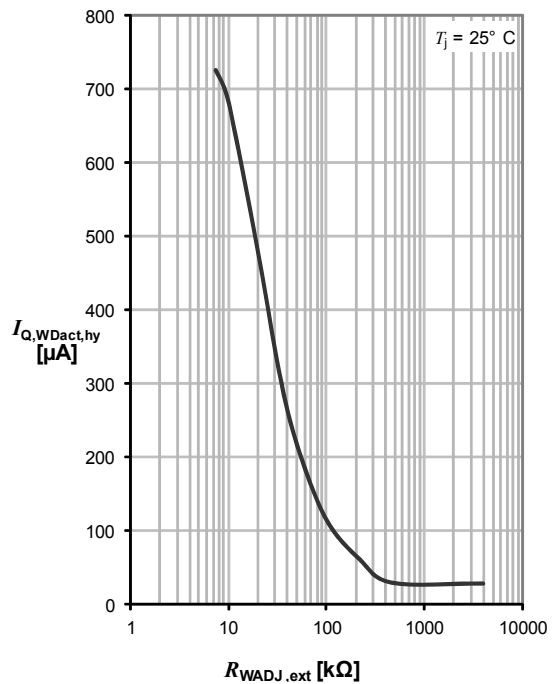

9 Application Information

Note: The following information is given as a hint for the implementation of the device only and shall not be regarded as a description or warranty of a certain functionality, condition or quality of the device.

9.1 Application Diagram

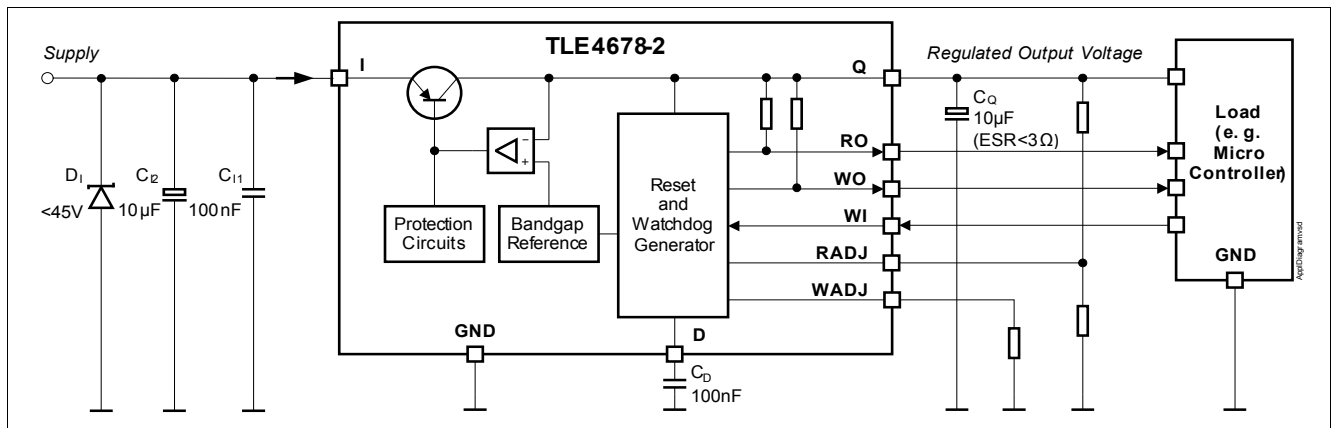

Figure 11 Application Diagram

9.2 Selection of External Components

9.2.1 Input Pin

The typical input circuitry for a linear voltage regulator is shown in the application diagram above.

A ceramic capacitor at the input, in the range of 100nF to 470nF, is recommended to filter out the high frequency disturbances imposed by the line e.g. ISO pulses 3a/b. This capacitor must be placed very close to the input pin of the linear voltage regulator on the PCB.

An aluminum electrolytic capacitor in the range of 10µF to 470µF is recommended as an input buffer to smooth out high energy pulses, such as ISO pulse 2a. This capacitor should be placed close to the input pin of the linear voltage regulator on the PCB.

An overvoltage suppressor diode can be used to further suppress any high voltage beyond the maximum rating of the linear voltage regulator and protect the device against any damage due to over-voltage above 45 V.

The external components at the input are not mandatory for the operation of the voltage regulator, but they are recommended in case of possible external disturbances.

9.2.2 Output Pin

An output capacitor is mandatory for the stability of linear voltage regulators.

The requirement to the output capacitor is given in **“Functional Range” on Page 8**. The graph **“Output Capacitor Series Resistor ESR_{CQ} versus Output Current I_Q” on Page 12** shows the stable operation range of the device.

TLE4678-2 is designed to be stable with extremely low ESR capacitors. According to the automotive requirements, ceramic capacitors with X5R or X7R dielectrics are recommended.

The output capacitor should be placed as close as possible to the regulator’s output and GND pins and on the same side of the PCB as the regulator itself.

In case of rapid transients of input voltage or load current, the capacitance should be dimensioned in accordance and verified in the real application that the output stability requirements are fulfilled.

9.3 Thermal Considerations

Knowing the input voltage, the output voltage and the load profile of the application, the total power dissipation can be calculated:

$$P_D = (V_I - V_Q) \times I_Q + V_I \times I_q \quad (8)$$

with

- P_D : continuous power dissipation
- V_I : input voltage
- V_Q : output voltage
- I_Q : output current
- I_q : quiescent current

The maximum acceptable thermal resistance R_{thJA} can then be calculated:

$$R_{thJA,max} = (T_{j,max} - T_a) / P_D \quad (9)$$

with

- $T_{j,max}$: maximum allowed junction temperature
- T_a : ambient temperature

Based on the above calculation the proper PCB type and the necessary heat sink area can be determined with reference to the specification in [“Thermal Resistance” on Page 8](#).

Example

Application conditions:

$$V_I = 13.5V$$

$$V_Q = 5V$$

$$I_Q = 50mA$$

$$T_a = 85^\circ C$$

Calculation of $R_{thJA,max}$:

$$\begin{aligned} P_D &= (V_I - V_Q) \times I_Q + V_I \times I_q \\ &= (13.5V - 5V) \times 50mA + 13.5V \times 1.6mA \\ &= 0.425W + 0.022W \\ &= 0.447W \end{aligned}$$

$$\begin{aligned} R_{thJA,max} &= (T_{j,max} - T_a) / P_D \\ &= (150^\circ C - 85^\circ C) / 0.447W = 145.41K/W \end{aligned}$$

As a result, the PCB design must ensure a thermal resistance R_{thJA} lower than 145.41 K/W. According to [“Thermal Resistance” on Page 8](#), at least 300 mm² heatsink area is needed on the FR4 1s0p PCB, or the FR4 2s2p board can be used.

9.4 Reverse Polarity Protection

TLE4678-2 is self protected against reverse polarity faults and allows negative supply voltage. External reverse polarity diode is not needed. However, the absolute maximum ratings of the device as specified in **“Absolute Maximum Ratings” on Page 7** must be kept.

The reverse voltage causes several small currents to flow into the IC hence increasing its junction temperature. As the thermal shut down circuitry does not work in the reverse polarity condition, designers have to consider this in their thermal design.

9.5 Further Application Information

- For further information you may contact <http://www.infineon.com/>

10 Package Outlines

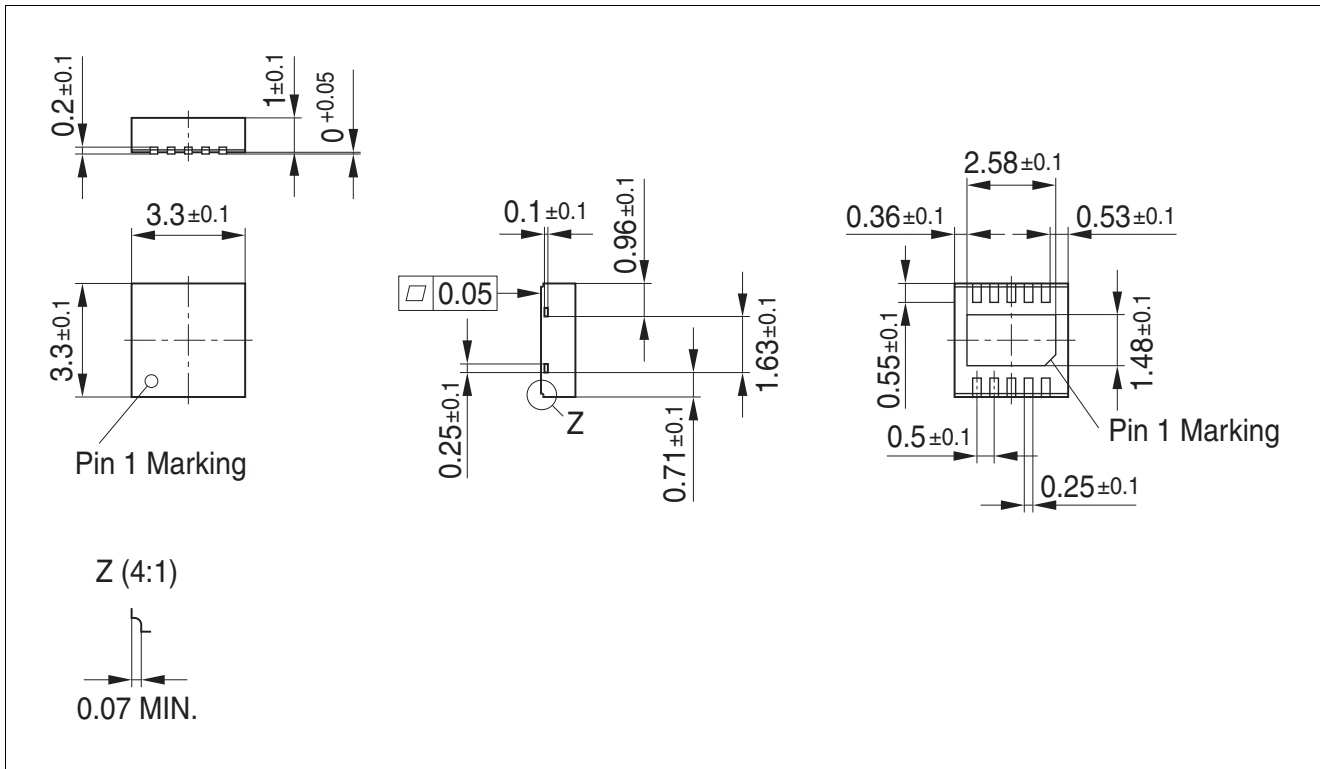

Figure 12 PG-TSON10

Green Product (RoHS compliant)

To meet the world-wide customer requirements for environmentally friendly products and to be compliant with government regulations the device is available as a green product. Green products are RoHS-Compliant (i.e Pb-free finish on leads and suitable for Pb-free soldering according to IPC/JEDEC J-STD-020).

11 Revision History

Revision	Date	Changes
1.0	2014-03-03	Initial version

Edition 2014-03-03

**Published by
Infineon Technologies AG
81726 Munich, Germany**

**© 2014 Infineon Technologies AG
All Rights Reserved.**

Legal Disclaimer

The information given in this document shall in no event be regarded as a guarantee of conditions or characteristics. With respect to any examples or hints given herein, any typical values stated herein and/or any information regarding the application of the device, Infineon Technologies hereby disclaims any and all warranties and liabilities of any kind, including without limitation, warranties of non-infringement of intellectual property rights of any third party.

Information

For further information on technology, delivery terms and conditions and prices, please contact the nearest Infineon Technologies Office (www.infineon.com).

Warnings

Due to technical requirements, components may contain dangerous substances. For information on the types in question, please contact the nearest Infineon Technologies Office.

Infineon Technologies components may be used in life-support devices or systems only with the express written approval of Infineon Technologies, if a failure of such components can reasonably be expected to cause the failure of that life-support device or system or to affect the safety or effectiveness of that device or system. Life support devices or systems are intended to be implanted in the human body or to support and/or maintain and sustain and/or protect human life. If they fail, it is reasonable to assume that the health of the user or other persons may be endangered.

X-ON Electronics

Largest Supplier of Electrical and Electronic Components

Click to view similar products for [LDO Voltage Regulators](#) category:

Click to view products by [Infineon](#) manufacturer:

Other Similar products are found below :

[AP7363-SP-13](#) [L79M05TL-E](#) [PT7M8202B12TA5EX](#) [TCR3DF185,LM\(CT](#) [TCR3DF24,LM\(CT](#) [TCR3DF285,LM\(CT](#) [TCR3DF31,LM\(CT](#)
[TCR3DF45,LM\(CT](#) [MP2013GQ-33-Z](#) [059985X](#) [NCP4687DH15T1G](#) [701326R](#) [TCR2EN28,LF\(S](#) [NCV8170AXV250T2G](#)
[TCR3DF125,LM\(CT](#) [TCR2EN18,LF\(S](#) [AP7315-25W5-7](#) [IFX30081LDVGRNXUMA1](#) [NCV47411PAAJR2G](#) [AP2113KTR-G1](#) [AP2111H-](#)
[1.2TRG1](#) [ZLDO1117QK50TC](#) [AZ1117IH-1.8TRG1](#) [TCR3DG12,LF](#) [MIC5514-3.3YMT-T5](#) [MIC5512-1.2YMT-T5](#) [MIC5317-2.8YM5-T5](#)
[SCD7912BTG](#) [NCP154MX180270TAG](#) [SCD33269T-5.0G](#) [NCV8170BMX330TCG](#) [NCV8170AMX120TCG](#) [NCP706ABMX300TAG](#)
[NCP153MX330180TCG](#) [NCP114BMX075TCG](#) [MC33269T-3.5G](#) [CAT6243-ADJCMT5T](#) [TCR3DG33,LF](#) [AP2127N-1.0TRG1](#)
[TCR4DG35,LF](#) [LT1117CST-3.3](#) [LT1117CST-5](#) [TAR5S15U\(TE85L,F\)](#) [TAR5S18U\(TE85L,F\)](#) [TCR3UG19A,LF](#) [TCR4DG105,LF](#)
[NCV8170AMX360TCG](#) [MIC94310-NYMT-T5](#) [TLE4268GSXUMA2](#) [NCV8186BMN175TAG](#)