

TLE4953x

Differential Hall Effect Transmission Speed Sensors

TLE4953C
TLE4953

Data Sheet

Version 4.1, 2018-01-02

Edition 2018-01-02

**Published by
Infineon Technologies AG
81726 Munich, Germany**

**© 2018 Infineon Technologies AG
All Rights Reserved.**

Legal Disclaimer

The information given in this document shall in no event be regarded as a guarantee of conditions or characteristics. With respect to any examples or hints given herein, any typical values stated herein and/or any information regarding the application of the device, Infineon Technologies hereby disclaims any and all warranties and liabilities of any kind, including without limitation, warranties of non-infringement of intellectual property rights of any third party.

Information

For further information on technology, delivery terms and conditions and prices, please contact the nearest Infineon Technologies Office (www.infineon.com).

Warnings

Due to technical requirements, components may contain dangerous substances. For information on the types in question, please contact the nearest Infineon Technologies Office.

Infineon Technologies components may be used in life-support devices or systems only with the express written approval of Infineon Technologies, if a failure of such components can reasonably be expected to cause the failure of that life-support device or system or to affect the safety or effectiveness of that device or system. Life support devices or systems are intended to be implanted in the human body or to support and/or maintain and sustain and/or protect human life. If they fail, it is reasonable to assume that the health of the user or other persons may be endangered.

Revision History

Page or Item	Subjects (major changes since previous revision)
Previous Version 4.0, 2010-04	
7	Ordering Code changed
11	Number of power on cycles added

Trademarks of Infineon Technologies AG

AURIX™, C166™, CanPAK™, CIPOS™, CIPURSE™, EconoPACK™, CoolMOS™, CoolSET™, CORECONTROL™, CROSSAVE™, DAVE™, DI-POL™, EasyPIM™, EconoBRIDGE™, EconoDUAL™, EconoPIM™, EconoPACK™, EiceDRIVER™, eupec™, FCOS™, HITFET™, HybridPACK™, I²RF™, ISOFACE™, IsoPACK™, MIPAQ™, ModSTACK™, my-d™, NovalithIC™, OptiMOS™, ORIGA™, POWERCODE™, PRIMARION™, PrimePACK™, PrimeSTACK™, PRO-SIL™, PROFET™, RASIC™, ReverSave™, SatRIC™, SIEGET™, SINDRION™, SIPMOS™, SmartLEWIS™, SOLID FLASH™, TEMPFET™, thinQ!™, TRENCHSTOP™, TriCore™.

Other Trademarks

Advance Design System™ (ADS) of Agilent Technologies, AMBA™, ARM™, MULTI-ICE™, KEIL™, PRIMECELL™, REALVIEW™, THUMB™, μVision™ of ARM Limited, UK. AUTOSAR™ is licensed by AUTOSAR development partnership. Bluetooth™ of Bluetooth SIG Inc. CAT-ig™ of DECT Forum. COLOSSUS™, FirstGPS™ of Trimble Navigation Ltd. EMV™ of EMVCo, LLC (Visa Holdings Inc.). EPCOS™ of Epcos AG. FLEXGO™ of Microsoft Corporation. FlexRay™ is licensed by FlexRay Consortium. HYPERTERMINAL™ of Hilgraeve Incorporated. IEC™ of Commission Electrotechnique Internationale. IrDA™ of Infrared Data Association Corporation. ISO™ of INTERNATIONAL ORGANIZATION FOR STANDARDIZATION. MATLAB™ of MathWorks, Inc. MAXIM™ of Maxim Integrated Products, Inc. MICROTEC™, NUCLEUS™ of Mentor Graphics Corporation. MIPI™ of MIPI Alliance, Inc. MIPS™ of MIPS Technologies, Inc., USA. muRata™ of MURATA MANUFACTURING CO., MICROWAVE OFFICE™ (MWO) of Applied Wave Research Inc., OmniVision™ of OmniVision Technologies, Inc. Openwave™ Openwave Systems Inc. RED HAT™ Red Hat, Inc. RFMD™ RF Micro Devices, Inc. SIRIUS™ of Sirius Satellite Radio Inc. SOLARIS™ of Sun Microsystems, Inc. SPANSION™ of Spansion LLC Ltd. Symbian™ of Symbian Software Limited. TAIYO YUDEN™ of Taiyo Yuden Co. TEAKLITE™ of CEVA, Inc. TEKTRONIX™ of Tektronix Inc. TOKO™ of TOKO KABUSHIKI KAISHA TA. UNIX™ of X/Open Company Limited. VERILOG™, PALLADIUM™ of Cadence Design Systems, Inc. VLYNQ™ of Texas Instruments Incorporated. VXWORKS™, WIND RIVER™ of WIND RIVER SYSTEMS, INC. ZETEX™ of Diodes Zetex Limited.

Last Trademarks Update 2011-11-11

Table of Contents

	Table of Contents	4
	List of Figures	5
	List of Tables	6
1	General	7
1.1	Target Application	7
1.2	Features	7
2	Functional Description	8
2.1	Circuit description	9
2.2	Speed signal circuitry	9
2.3	Uncalibrated mode	9
2.4	Direction signal circuitry	10
2.5	Vibration suppression algorithm	10
3	Specifications	11
3.1	Absolute Maximum Ratings	11
3.2	ESD Robustness	12
3.3	Operating Range	12
3.4	Electrical Characteristics	13
3.5	Timing Characteristics	14
3.6	Electro Magnetic Compatibility	16
4	Package Information	18

List of Figures

Figure 2-1	Block Diagram	8
Figure 2-2	Output Pulses on magnetic rising edge	8
Figure 2-3	Definition of Rotation Direction	9
Figure 3-1	Definition of PWM Current Interface	15
Figure 3-2	Definition of Rise and Fall Time	15
Figure 3-3	EMC test circuit	17
Figure 4-1	Pin Configuration (top view)	18
Figure 4-2	Package Outline	18
Figure 4-3	PG-SSO-2-1 (Plastic Single Small Outline Package)	19
Figure 4-4	PG-SSO-2-4 (Plastic Single Small Outline Package)	20

List of Tables

Table 3-1	Absolute Maximum Ratings	11
Table 3-2	ESD Protection	12
Table 3-3	Operating Range	12
Table 3-4	Electrical Characteristics	13
Table 3-5	Timing Characteristics	15
Table 3-6	Conducted Pulses	16
Table 3-7	Coupled Pulses	16
Table 3-8	TEM-cell measurement	16

1 General

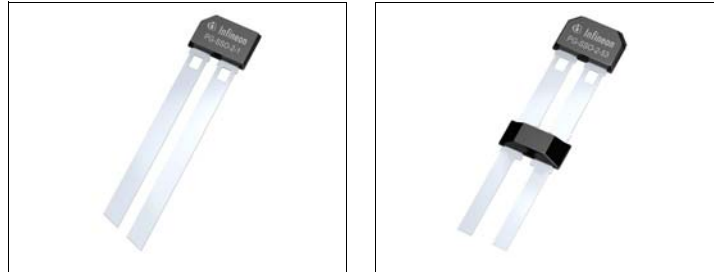

1.1 Target Application

The differential Hall Effect sensor TLE4953 is designed to provide information about rotational speed and direction of rotation to modern transmission and ABS systems. The output has been designed as a two wire current interface based on a Pulse Width Modulation principle. The sensor operates without external components and combines a fast power-up time with a wide frequency range. Excellent accuracy and sensitivity is specified for harsh automotive requirements as a wide temperature range, high ESD robustness and high EMC resilience. State-of-the-art BiCMOS technology is used for monolithic integration of the active sensor areas and the signal conditioning. Finally, the optimized piezo compensation and the integrated dynamic offset compensation enable easy manufacturing and elimination of magnetic offsets. Adaptive hysteresis concept increases the noise immunity. The TLE4953C is additionally provided with an overmolded 1.8 nF capacitor for improved EMI performance.

1.2 Features

- Two-wire PWM current interface
- Detection of rotation direction
- Dynamic self-calibration principle & high sensitivity
- Adaptive hysteresis
- Single chip solution - no external components
- Vibration suppression in calibrated mode
- South and north pole pre-induction possible
- High resistance to piezo effects
- Large operating air-gaps
- Wide operating temperature range
- From zero speed up to 12 kHz
- 1.8 nF overmolded capacitor
- For coarse transmission target wheels
- Module style package with integrated overmolded capacitor¹⁾
 - 1.8nF between V_{DD} and GND
- AEC-Q100 qualified

Product Name	Ordering Code	Marking	Package
TLE4953C	SP001952920	53C1R	PG-SSO-2-4
TLE4953	SP000278512	53	PG-SSO-2-1

1) Value capacitor: 1.8nF +/-10% (excluded drift because of temperature and over lifetime); ceramic: X8R; maximum voltage: 50V

2 Functional Description

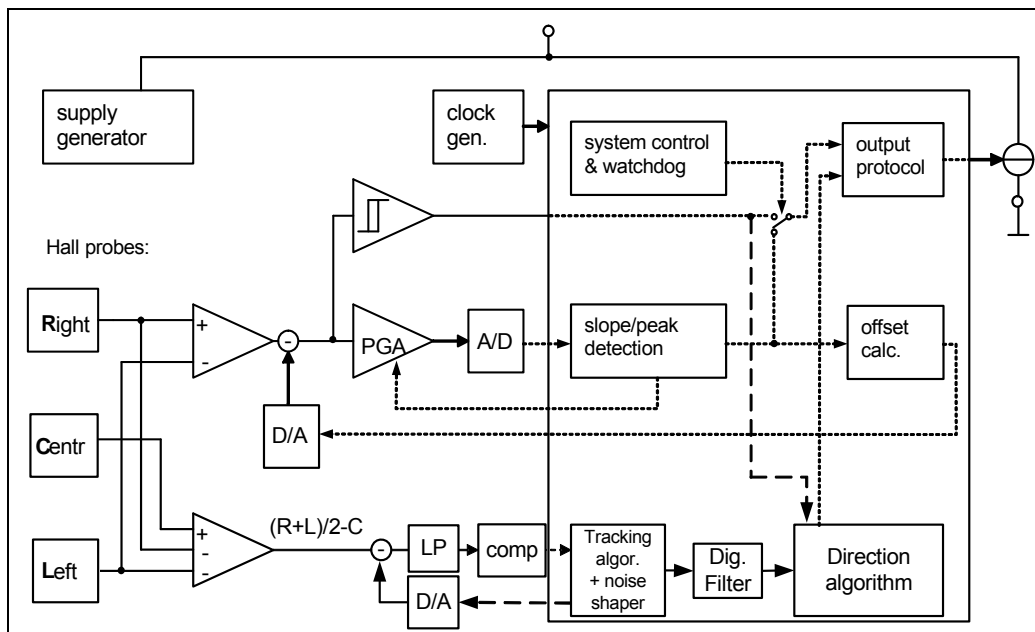

Figure 2-1 Block Diagram

The differential Hall Effect IC detects the motion of ferromagnetic or permanent magnet structures by measuring the differential flux density of the magnetic field. To detect the motion of ferromagnetic objects the magnetic field must be provided by a backbiasing permanent magnet. Either the South or North pole of the magnet can be attached to the rear, unmarked side (remark: rear side may contain data matrix code) of the IC package.

Magnetic offsets of up to ± 20 mT and mechanical offsets are cancelled out through a self-calibration algorithm. Only 2 transitions are necessary for the self-calibration procedure. After the initial self-calibration sequence switching occurs when the input signal crosses the adaptive threshold on the rising magnetic edge.

The ON and OFF state of the IC are indicated by High and Low current consumption. Each rising magnetic edge of the magnetic input signal triggers an output pulse.

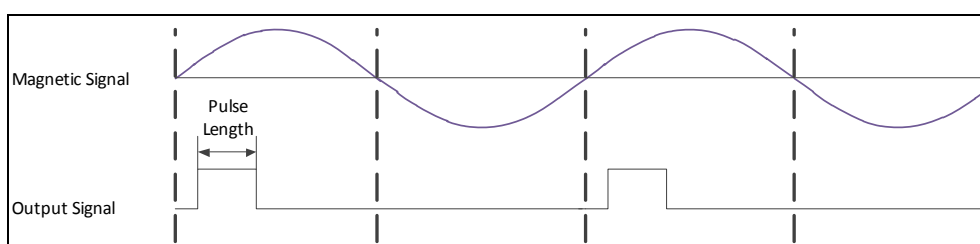

Figure 2-2 Output Pulses on magnetic rising edge

In addition to the speed signal, the following information is provided by varying the length of the output pulses (PWM modulation):

Speed signal = **S**

The speed signal is issued at the first output pulse after start up and when the magnetic frequency is above 1kHz.

Direction of rotation left = **DR-L**

DR-L information is issued in the output pulse length when the active target wheel in front of the Hall Effect IC moves from the pin VCC to the pin GND.

Direction of rotation right = **DR-R**

DR-R information is issued in the output pulse length when the active target wheel in front of the Hall Effect IC moves from the pin GND to the pin VCC.

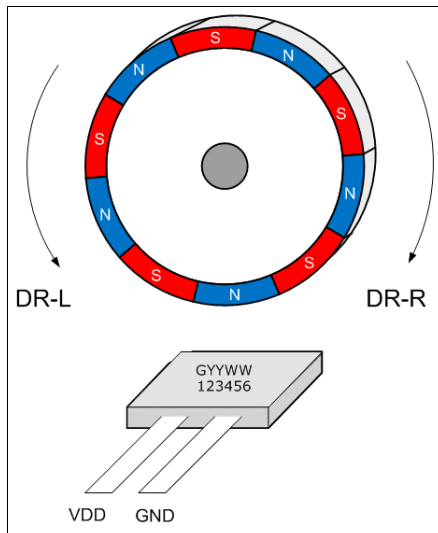

Figure 2-3 Definition of Rotation Direction

2.1 Circuit description

The circuit internally is supplied by a voltage regulator. A 2 MHz on-chip oscillator serves as a clock generator for the DSP and the output encoder.

2.2 Speed signal circuitry

TLE4953 speed signal path comprises a pair of Hall Effect probes, separated from each other by 2.5 mm, a differential amplifier including noise limiting low-pass filter, and a comparator triggering a switched current output stage. An offset cancellation feedback loop is provided through a signal-tracking A/D converter, a digital signal processor (DSP), and an offset cancellation D/A converter.

2.3 Uncalibrated mode

Occasionally a short initial offset settling time $t_{d,input}$ might delay the detection of the input signal. (The sensor is "blind"). During the startup phase (un-calibrated mode) the output is disabled ($I = I_{Low}$). The magnetic input signal is tracked by the speed ADC and monitored within the digital circuit. For detection the signal needs to exceed a threshold (digital noise constant $d1$). When the signal slope is identified as a rising edge, a trigger pulse is issued to a comparator. A second trigger pulse is issued as soon as the next rising edge is detected.

Between the start-up of the magnetic input signal and the time when its second extreme is reached, the PGA (programmable gain amplifier) will switch to its appropriate position. This value is determined by the signal amplitude and initial offset value. The digital noise constant value is changing accordingly ($d1 \rightarrow d2$, related to the corresponding PGA states), leading to a change in phase shift between magnetic input signal and output signal. After that consecutive output edges should have a nominal delay of about 360° . During the uncalibrated mode the offset value is calculated by the peak detection algorithm as described below.

The differential input signal is digitized in the speed A/D converter and fed into the DSP part of the circuit. The minimum and maximum values of the input signal are extracted and their corresponding arithmetic mean value is calculated. The offset of this mean value is determined and fed into the offset cancellation DAC.

The offset update takes place when two valid extremes are found and the direction of the update has the same orientation as the magnetic slope (valid for calibrated mode). For example an positive offset update is only possible on a rising magnetic edge. The offset update is done independant from the output switching.

After successful correction of the offset, the output switching is in calibrated mode. Switching occurs at adaptive threshold-crossover. It is only affected by the propagation delay time of the signal path, which is mainly determined by the noise limiting filter. Signals which are below a predefined threshold ΔB_{Limit} are not detected. This prevents unwanted switching.

The adaptive hysteresis is linked to the PGA state. Therefore the system is able to suppress switching if vibration or noise signals are smaller than the adaptive hysteresis.

The switching and direction information is fed into the DSP and the output encoder. The pulse length of the High output current is generated according to the rotational speed and the direction of rotation

2.4 Direction signal circuitry

The differential signal between a third Hall probe and the mean value of the differential Hall probe pair is obtained from the direction input amplifier. This signal is digitized by the direction ADC and fed into the digital circuitry. There, the phase of the signal referring to the speed signal is analyzed and the direction information is forwarded to the output encoder. The phase is identified by calculating the size of the direction signal at two consecutive zero crossings of the speed signal. This is done by subtracting the current direction signal from the internal stored value which has been taken from the previous magnetic edge.

Depending on the phase shift between the direction signal and the speed signal a positive or a negative value occur. The information if the new direction calculation takes place at a rising or a falling magnetic edge allows together with the algebraic sign of the calculated direction signal a reliable direction detection.

The first pulse after power is always a speed pulse as there is no stored direction information available.

2.5 Vibration suppression algorithm

The magnetic signal amplitude and the direction information is used for detection of parasitic magnetic signals. Unwanted magnetic signals can be caused by angular or airgap vibrations for instance. If an input signal is clearly detected as a vibration signal, the output of pulses will be suppressed.

A magnetic input signal is classified as parasitic vibration signal if

- a. the speed signal amplitude is smaller than the internal hysteresis or
- b. the direction signal amplitude is smaller than the internal limit or
- c. the direction signal consists of alternating left/right information

The quality of vibration suppression (according a & b) depends on the hysteresis limits and on the magnitude of the magnetic signal. The bigger the hysteresis the better the suppression of parasitic signals.

For parasitic signals where items above (a. to c.) are not clearly applicable or at other more rare cases (e.g. IC startup) vibration suppression is not guaranteed. The performance of the direction detection and vibration suppression algorithm depends on the used magnetic circuit and as well on the used target wheel and need to be evaluated.

Please ask for application support if you have questions on the vibration suppression algorithm.

3 Specifications

Attention: Stresses above the max. values listed here may cause permanent damage to the device. Exposure to absolute maximum rating conditions for extended periods may affect device reliability. Maximum ratings are absolute ratings; exceeding only one of these values may cause irreversible damage to the integrated circuit

3.1 Absolute Maximum Ratings

Table 3-1 Absolute Maximum Ratings

Parameter	Symbol	Values		Unit	Note / Test Condition
		Min.	Max.		
Supply voltage	V_{DD}	-0.3		V	$T_j \leq 80\text{ }^\circ\text{C}$
			16.5	V	$T_j = 170\text{ }^\circ\text{C}$
			20	V	$T_j = 150\text{ }^\circ\text{C}$
			22	V	$t = 10 \times 5\text{ min.}$
			24	V	$t = 10 \times 5\text{ min.}; R_M \geq 75\ \Omega$ included in V_{CC}
			27	V	$t = 400\text{ms}, R_M \geq 75\ \Omega$, included in V_{CC}
Junction temperature	T_j	-	150	$^\circ\text{C}$	5000 h, $V_{CC} \leq 16.5\text{ V}$
		-	160	$^\circ\text{C}$	2500 h, $V_{CC} \leq 16.5\text{ V}$ (not additive)
		-	170	$^\circ\text{C}$	500 h, $V_{CC} \leq 16.5\text{ V}$ (not additive)
		-	190	$^\circ\text{C}$	4 x 1 h, $V_{CC} \leq 16.5\text{ V}$
Number of power on cycles	n_{po}	10^6		cycles	
Reverse polarity current	I_{rev}	-	200	mA	External current limitation required, $t \leq 4\text{ h}^1)$
Active lifetime ²⁾	$t_{B,active}$	-	10000	h	$-40\text{ }^\circ\text{C}$ to $125\text{ }^\circ\text{C}$
Thermal resistance (PG-SSO-2-53)	R_{thJA}		190	K/W	³⁾

- 1) This allows together with an external serial resistor (75 or 100 Ohm) reverse polarity voltage for a short duration. This resistor is usually present in the ECU of the application circuit
- 2) Life time shall be considered as anticipation and will not extend the agreed warranty period
- 3) Can be improved significantly by further processing like overmolding

Note: Stress in excess of those listed here may cause permanent damage to the device. Exposure to absolute maximum rating conditions for extended periods may affect device reliability.

3.2 ESD Robustness

Characterized according to Human Body Model (HBM) test in compliance with standard EIA/JESD22-A114-B HBM (covers MIL STD 883D)

Table 3-2 ESD Protection

Parameter	Symbol	Values		Unit	Note
		min.	max.		
ESD-Protection TLE4953C TLE4953	V_{ESD}	-	± 12	kV	$R = 1.5 \text{ k}\Omega$, $C = 100 \text{ pF}$

3.3 Operating Range

All parameters specified in the following sections refer to these operating conditions unless otherwise noticed

Table 3-3 Operating Range

Parameter	Symbol	Values			Unit	Note / Test Condition
		Min.	Typ.	Max.		
Supply voltage	V_{CC}	4.5		20	V	Directly on the IC leads excludes the R_M voltage drop
Supply voltage	V_{CC}	4.0		4.5	V	Directly on the IC leads excludes the R_M voltage drop ¹⁾
Supply voltage ripple	V_{AC}	-		6	Vpp	$V_{CC} = 13 \text{ V}$ $0 \leq f \leq 50 \text{ kHz}$
Jjunction temperature	T_j or	-10		150	°C	
				170	°C	500h $V_{CC} \leq 16.5 \text{ V}^2)$
Pre-induction	B_0	-500		+500	mT	
Pre-induction offset between outer probes	$\Delta B_{stat., l/r}$	-20		+20	mT	L-R
Pre-induction offset between mean of outer probes and center probe	$\Delta B_{stat., m/o}$	-20		20	mT	(L+R)/2-C
Differential	ΔB	-120		+120	mT	

1) Reduced performance possible for jitter/phase accuracy and power supply rejection ratio (EMC). Current levels will typically decrease but will be within specification limits. This voltage range is not recommended for continuous operation and should cover the function during short voltage drops which may occur at cranking of engine / test pulse 4.

2) Increased jitter and reduced phase accuracy permissible between 150 and 170°C junction temperature.

Note: Within the operating range the functions given in the circuit description are fulfilled.

3.4 Electrical Characteristics

All values specified at constant amplitude and offset of input signal, over operating range, unless otherwise specified. Typical values correspond to $V_{DD} = 12\text{ V}$ and $T_j = 25\text{ °C}$

Table 3-4 Electrical Characteristics

Parameter	Symbol	Values			Unit	Note / Test Condition
		Min.	Typ.	Max.		
Supply current low	I_{Low}	5.9	7	8.4	mA	
Supply current high	I_{High}	11.8	14	16.8	mA	
Supply current ratio	I_{High}/I_{Low}	1.9	-	-		
Output rise/fall slew rate TLE4953	t_r, t_f	12	-	26	mA/ μ s	$R_M = 75\ \Omega$, $T_j \leq 170\text{ °C}$
Output rise/fall slew rate TLE4953C	t_r, t_f	8	-	26	mA/ μ s	$R_M = 75\ \Omega$, $T_j \leq 170\text{ °C}$
Current ripple dI_x/dV_{cc}	I_x	-	-	90	μ A/V	Only valid for TLE4953
Limit threshold speed $0\text{ Hz} \leq f \leq 2500\text{ Hz}$ $2500\text{ Hz} \leq f \leq 12000\text{ Hz}$	ΔB_{Limit}	0.35	0.8	1.5 1.75	mT	Peak to peak value 50% criteria ¹⁾
Limit differential direction signal $0\text{ Hz} \leq f \leq 1100\text{ Hz}$	ΔB_{Dir}		0.35	0.73	mT	Peak to peak value 99% criteria ¹⁾²⁾
Initial calibration delay time	$t_{d,input}$	-	300	345	μ s	Additional to n_{start}
Magnetic edges required for first output pulse (no previous vibration detected) ⁵⁾	n_{start}	-	-	2	magn. edges	pulse occurs only on rising magnetic edge
Number of pulse in uncalibrated mode ⁵⁾	$n_{DZ-Startup}$			2	pulses	3 rd pulse calibrated
Number of emitted pulses with invalid direction Information ³⁾	$n_{DR-Start}$	-	-	2 ⁴⁾	pulses	3 rd pulse correct
Frequency	f	0	-	12000	Hz	4)
Systematic phase error of output edges during start- up and uncalibrated mode		-88		+88	°	Systematical phase error of "uncal" pulse; nth vs. n+1th pulse (does not include jitter)
Phase shift during transition from uncalibrated to calibrated mode	$\Delta\Phi_{switch}$	-90		+90	°	
Phase shift change during PGA switching in calibrated mode		0		80	°	Due to adaptive hysteresis. Depending on signal shape.

Table 3-4 Electrical Characteristics (cont'd)

Parameter	Symbol	Values			Unit	Note / Test Condition
		Min.	Typ.	Max.		
Magnetic differential field change required for startup with 1st rising edge	$\Delta B_{\text{Limit,early startup}}$					peak to peak value
$\Delta B_{\text{Limit,early startup}}$				3.5	mT	
Period Jitter ⁵⁾ , $f \leq 2500$ Hz	$S_{\text{Jit-far}}, T_j \leq 150$ °C			± 2	%	⁵⁾ 1σ value, $V_{\text{DD}} = 12$ V, $\Delta B_{\text{speed}} \geq 4$ mT peak to peak
	$S_{\text{Jit-far}}, T_j \leq 170$ °C			± 3	%	
Period Jitter ⁵⁾ , $2500\text{Hz} < f \leq 12000$ Hz	$S_{\text{Jit-far}}, T_j \leq 150$ °C			± 3	%	⁵⁾ 1σ value, $V_{\text{DD}} = 12$ V, $\Delta B_{\text{speed}} \geq 4$ mT peak to peak
	$S_{\text{Jit-far}}, T_j \leq 170$ °C			± 4.5	%	
Jitter at board net ripple ⁵⁾	$S_{\text{Jit-AC}}$	-	-	± 2	%	$V_{\text{CC}} = 13$ V ± 3 Vpp; $0 \leq f \leq 50$ kHz $\Delta B_{\text{speed}} = 15$ mT

- 1) ΔB_{Limit} is calculated out of measured sensitivity.
- 2) 99% criterion stands for 1 out of 100 pulses is missing.
- 3) The first 2 pulses may contain only direction information if the direction signal is above DB_{Dir} . The first pulse after starting will be the speed pulse.
- 4) High frequency behaviour not subject to production test - verified by design/characterization.
- 5) Not subject to production test, verified by design/characterization.

3.5 Timing Characteristics

PWM Current Interface

Between each magnetic transition and the rising edge of the corresponding output pulse the output current is Low for $t_{\text{pre-low}}$ in order to allow reliable internal conveyance. Following the signal pulse (current is High) is output. If the magnetic direction field exceeds ΔB_{Dir} , the output pulse lengths are 60 μs or 120 μs respectively, depending on the direction of rotation. If the magnitude of the magnetic direction field is below ΔB_{Dir} , the output pulses are suppressed when the frequency is below $f_{\text{DR,max}}$ (see section vibration suppression). For magnitudes of the magnetic differential field below ΔB_{Limit} the signal is lost. Speed pulse occur only at the first pulse after start up or above $f_{\text{DR,max}}$. If no magnetic differential signal change is detected the IC will remain in calibrated mode. No internal reset are generated - therefore a zero speed operation is possible.

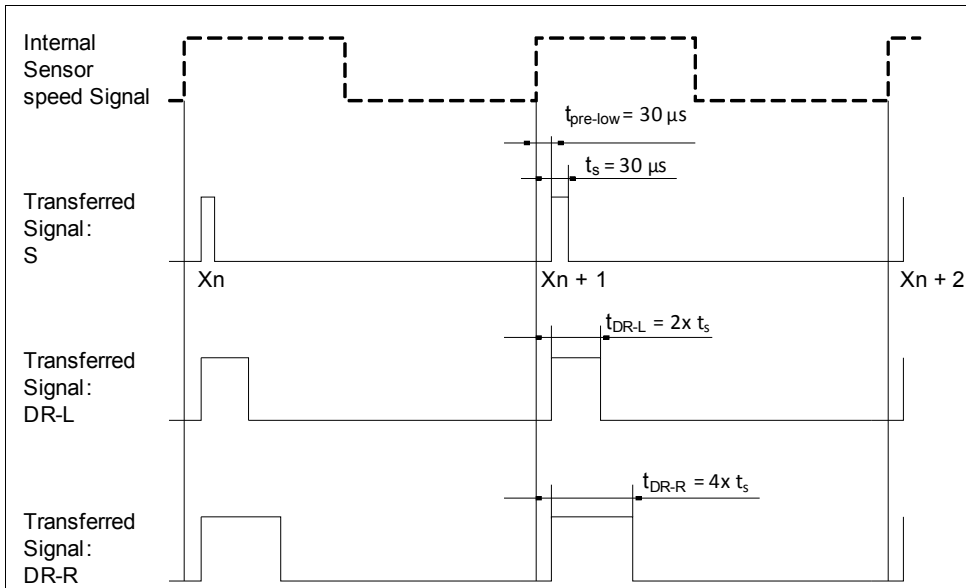

Figure 3-1 Definition of PWM Current Interface

Table 3-5 Timing Characteristics

Parameter	Symbol	Values			Unit	Note / Test Condition
		Min.	Typ.	Max.		
Pre-low length	$t_{pre-low}$	24	30	36	μs	
Speed signal	t_s	24	30	36	μs	
Length of DR-L pulse	t_{DR-L}	50	60	70	μs	
Length of DR-R pulse	t_{DR-R}	102	120	138	μs	
Output of DR-L/R pulse, maximum frequency	$f_{DR,max}$				Hz	Internal hysteresis of direction signal ¹⁾
From low - high frequency		935	1100	1265		
From high - low frequency		850	1000	1150		

1) Not possible overlap, 10% difference verified by design/characterization. Frequencies not subject to production test verified by design/characterization

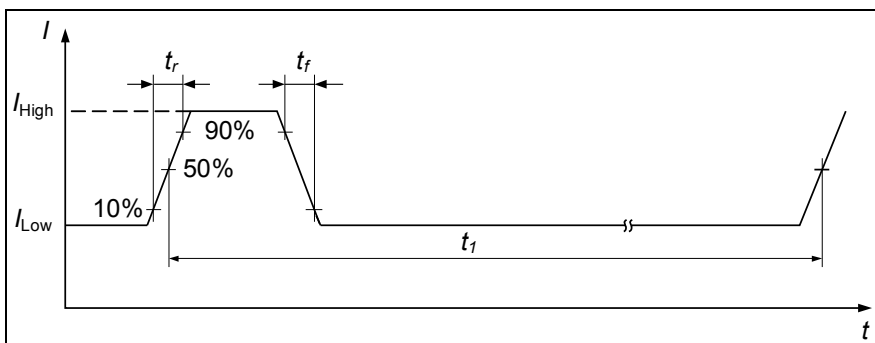

Figure 3-2 Definition of Rise and Fall Time

3.6 Electro Magnetic Compatibility

Electro Magnetic Compatibility (values depends on R_M !).

Note: Characterization of Electro Magnetic Compatibility is carried out on samples based on one qualification lot. Not all specification parameters have been monitored during EMC exposure. Only key parameters e.g. switching current have been monitored.

1. Ref. ISO 7637-1; test circuit 1;
 $\Delta B = 2 \text{ mT}$ (amplitude of sinus signal); $V_{CC} = 13.5\text{V}$, $f_B = 100 \text{ Hz}$; $T = 25 \text{ }^\circ\text{C}$; $R_M \geq 75 \text{ } \Omega$

Table 3-6 Conducted Pulses

Parameter	Symbol	Level/Type	Status
Ref. ISO 7637-1; test circuit 1; $\Delta B = 2 \text{ mT}$ (amplitude of sinus signal); $V_{CC} = 13.5\text{V}$, $f_B = 100 \text{ Hz}$; $T = 25 \text{ }^\circ\text{C}$; $R_M \geq 75 \text{ } \Omega$			
Testpulse 1	V_{EMC}	IV / -100 V	C ¹⁾
Testpulse 2		IV / 100 V	C ¹⁾
Testpulse 3a		IV / -150 V	A
Testpulse 3b		IV / 100 V	A
Testpulse 4		IV / -7 V	B ²⁾
Testpulse 5		IV / 86.5 ³⁾ V	C

- 1) According to 7637-1 the supply switched "OFF" for $t = 200 \text{ ms}$.
- 2) According to 7637-1 for test pulse 4 the test voltage shall be $12 \text{ V} \pm 0.2 \text{ V}$. Measured with $R_M = 75\text{W}$ only. Mainly the current consumption will decrease. Status C with test circuit 1.
- 3) Applying in the board net a suppressor diode with sufficient energy absorption capability.

Table 3-7 Coupled Pulses

Parameter	Symbol	Level/Typ	Status
Ref. ISO 7637-3; test circuit 1; $\Delta B = 2 \text{ mT}$ (amplitude of sinus signal); $V_{CC} = 13.5\text{V}$, $f_B = 100 \text{ Hz}$; $T = 25 \text{ }^\circ\text{C}$; $R_M \geq 75 \text{ } \Omega$			
Testpulse 1	V_{EMC}	IV / -30 V	A
Testpulse 2		IV / 30 V	A
Testpulse 3a		IV / -60 V	A
Testpulse 3b		IV / 40 V	A

Table 3-8 TEM-cell measurement

Parameter	Symbol	Level/Typ	Status
Ref. ISO 11452-3; test circuit 1; measured in TEM-cell $\Delta B = 2 \text{ mT}$; $V_{CC} = 13.5\text{V}$, $f_B = 100 \text{ Hz}$; $T = 25 \text{ }^\circ\text{C}$			
EMC field strength (TLE4953)	$E_{TemCell}$	IV / 200 V/m	AM = 80% $f = 1 \text{ kHz}$
EMC field strength (TLE4953C)	$E_{TemCell}$	IV / 250 V/m	AM=80% $f = 1 \text{ kHz}$

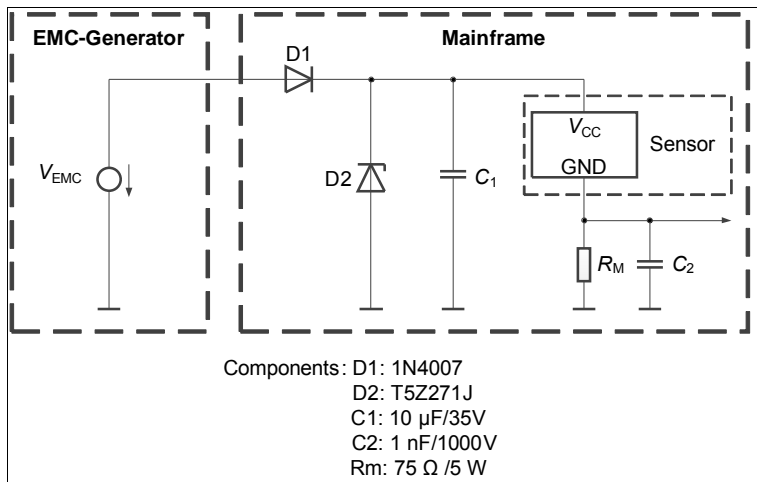

Figure 3-3 EMC test circuit

4 Package Information

Pure tin covering (green lead plating) is used. Lead frame material is Wieland K62 (UNS: C18090) and contains CuSn1CrNiTi. Product is RoHS (Restriction of Hazardous Substances) compliant and marked with letter G in front of the data code marking and may contain a data matrix code on the rear side of the package (see also information note 136/03). Please refer to your key account team or regional sales if you need further information.

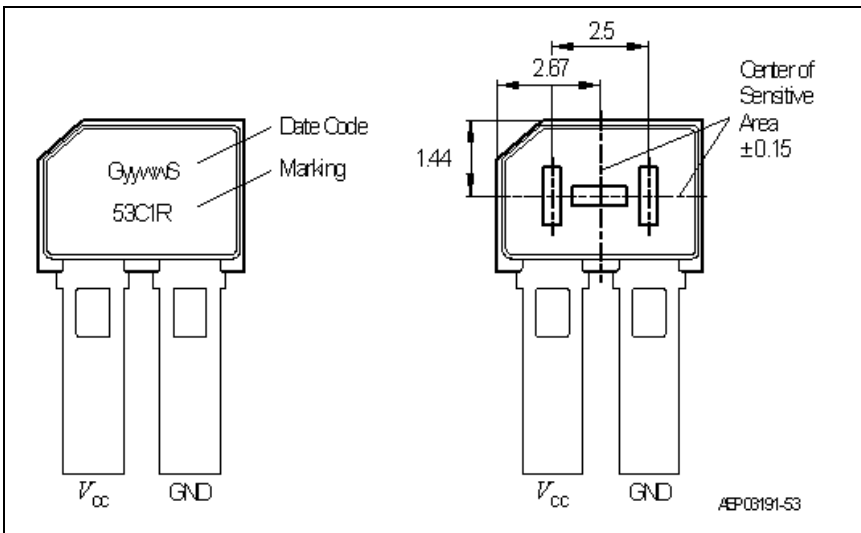

Figure 4-1 Pin Configuration (top view)

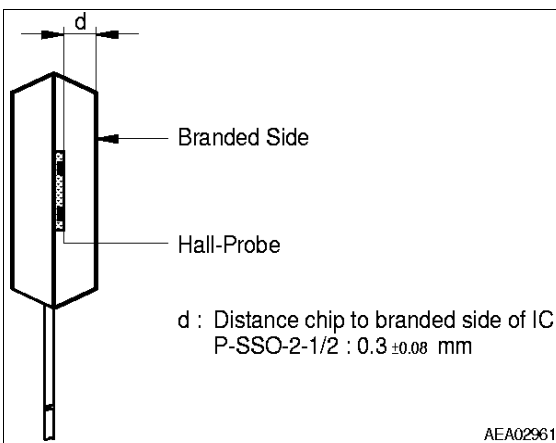

Figure 4-2 Package Outline

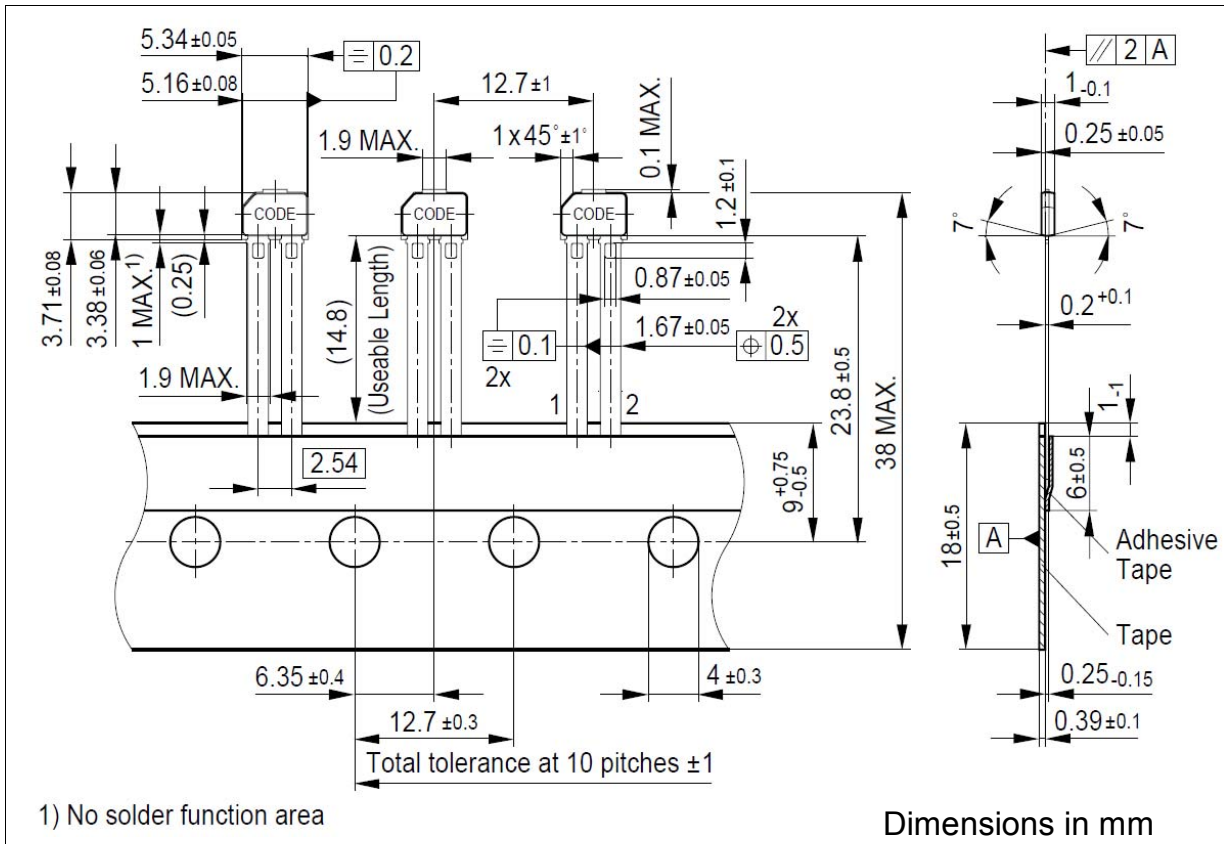

Figure 4-3 PG-SSO-2-1 (Plastic Single Small Outline Package)

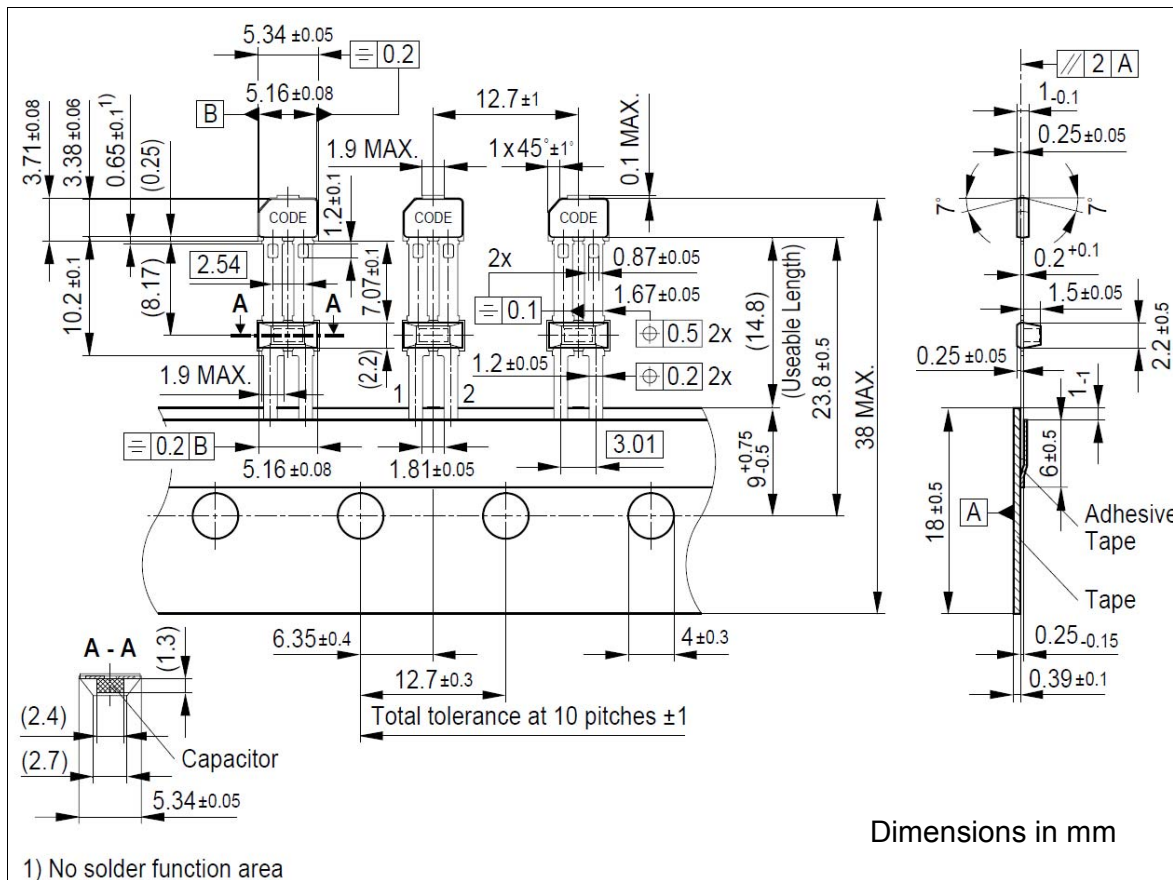

Figure 4-4 PG-SSO-2-4 (Plastic Single Small Outline Package)

For additional packages information, sort of packing and others, please see Infineon internet web page <http://www.infineon.com/products>

www.infineon.com

Published by Infineon Technologies AG

X-ON Electronics

Largest Supplier of Electrical and Electronic Components

Click to view similar products for [Board Mount Hall Effect/Magnetic Sensors](#) category:

Click to view products by [Infineon](#) manufacturer:

Other Similar products are found below :

[HGPRDT005A](#) [AH1808-P-A](#) [AH277AZ4-AG1](#) [AV-10379](#) [AV-10448](#) [SS41C](#) [AH1894-Z-7](#) [ATS601LSGTN-HT-WU4-T](#) [ATS601LSGTN-LT-WU4-T](#) [TLE4917](#) [50017859-003](#) [TY-13101](#) [SS85CA](#) [AH277AZ4-BG1](#) [TLE49614MXTSA1](#) [AH3382-P-B](#) [AH3377-P-B](#) [AH9250-W-7](#) [AH211Z4-AG1](#) [AH3360-FT4-7](#) [SS460S-100SAMPLE](#) [50065820-03](#) [TLE4941PLUSCB](#) [AH374-P-A](#) [AH1806-P-A](#) [AH374-W-7](#) [SS460P-T2](#) [AH1912-FA-7](#) [SS413F](#) [TLE5046ICAKLRHALA1](#) [TLE49421CHAMA2](#) [TLE4941PLUSCXAMA1](#) [AH1912-W-EVM](#) [AH1903-FA-EVM](#) [AH3774-W-EVM](#) [AH49FNTR-EVM](#) [MMC5633NJL](#) [AH3360-FA-EVM](#) [AH8502-FDC-EVM](#) [AH3366Q-SA-EVM](#) [AH3774-P-EVM](#) [KTH1601SU-ST3](#) [MG910](#) [MG910M](#) [MG911](#) [MG610](#) [MW921](#) [MW922](#) [TLE4998S3XALA1](#) [TLE5011FUMA1](#)