

TLE4966L

High Precision Hall-Effect Switch with Direction Detection

About this document

Features

- 2.7 V to 24 V supply voltage operation
- Operation from unregulated power supply
- High sensitivity and high stability of the magnetic switching points
- High resistance to mechanical stress by active error compensation
- Reverse battery protection (-18 V)
- Superior temperature stability
- Peak temperatures up to 195°C without damage
- Low jitter (typically 1 μ s)
- Digital output signals
- Bipolar version
- Excellent matching between the 2 Hall probes
- Hall plate distance 1.45 mm
- Direction & speed information
- Direction signal switches before the speed signal



Target applications

The TLE4966L is an integrated circuit double Hall-effect sensor designed specifically for highly accurate applications. Precise magnetic switching points and high temperature stability are achieved by active compensation circuits and chopper techniques on chip. The IC provides a speed signal at Q2 for every magnetic pole pair and a direction information at Q1, which is provided before the speed signal.

Product type	Package
TLE4966L	PG-SSO-4-1

Table of contents

	About this document	1
	Table of contents	2
1	Functional description	3
1.1	Pin configuration (top view)	3
2	General	4
2.1	Block diagram	4
2.2	Circuit description	4
3	Maximum ratings	5
3.1	Absolute maximum ratings	5
4	Operating range	6
5	Electrical and magnetic parameters	7
6	Timing diagrams for the speed and direction	9
7	Package information	11
7.1	Package marking	11
7.2	Distance between chip and package surface	11
7.3	Package outlines	12
8	Revision history	13
	Disclaimer	14

1 Functional description

1 Functional description

1.1 Pin configuration (top view)

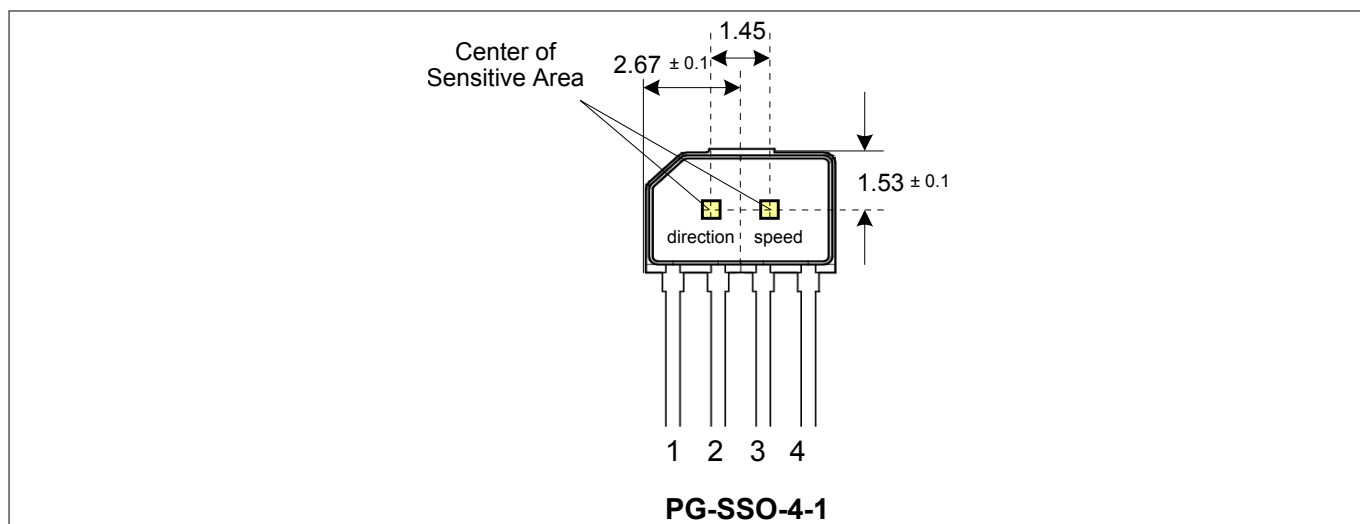

Figure 1 Pin definition and center of sensitive area

Table 1 Pin definitions and functions

Pin No.	Symbol	Function
1	V_S	Supply voltage
2	$Q1$	Direction
3	$Q2$	Speed
4	GND	Ground

2 General

2 General

2.1 Block diagram

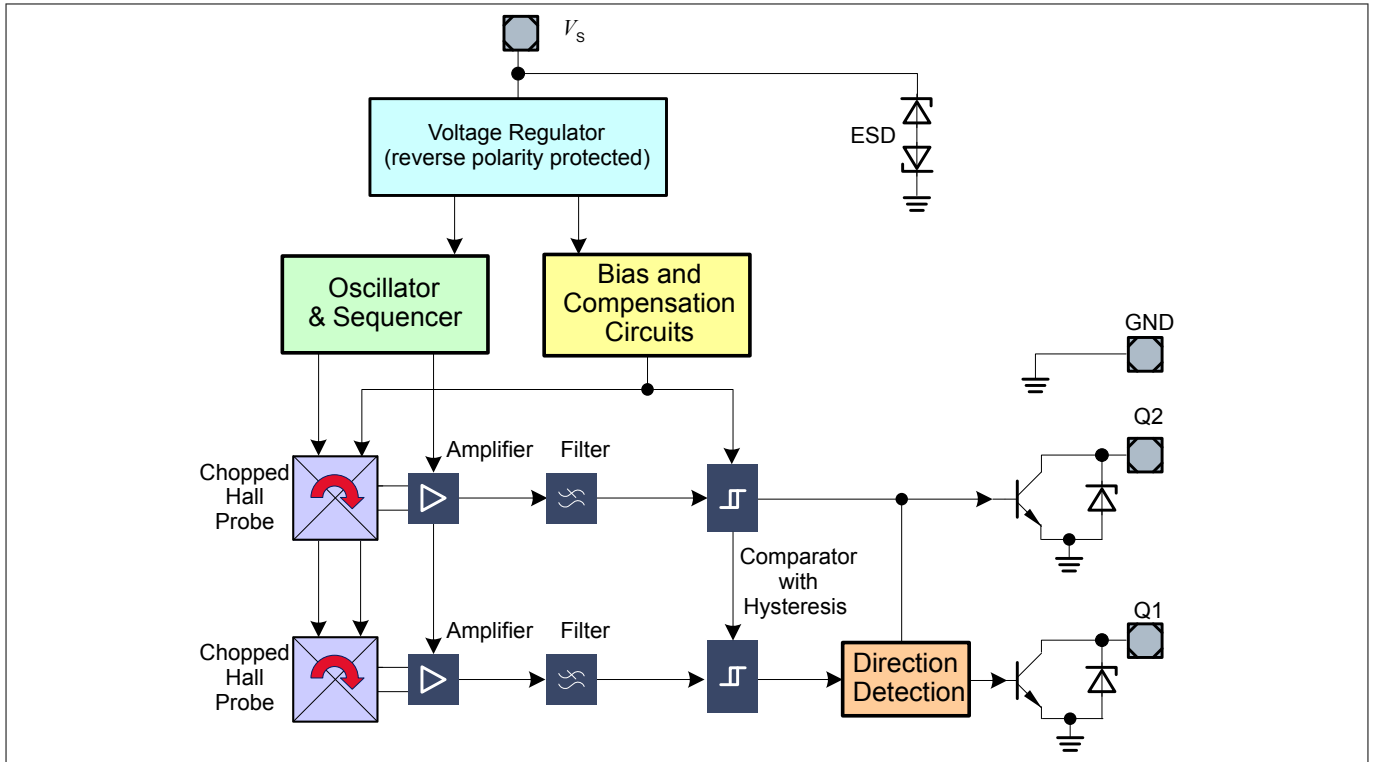

Figure 2 Block diagram

2.2 Circuit description

The chopped Double Hall Switch comprises two Hall probes, bias generator, compensation circuits, oscillator, and output transistors.

The bias generator provides currents for the Hall probes and the active circuits. Compensation circuits stabilize the temperature behavior and reduce technology variations.

The Active Error Compensation rejects offsets in signal stages and the influence of mechanical stress to the Hall probes caused by molding and soldering processes and other thermal stresses in the package. This chopper technique together with the threshold generator and the comparator ensures high accurate magnetic switching points.

3 Maximum ratings

3 Maximum ratings

3.1 Absolute maximum ratings

Table 2 Absolute maximum ratings

$T_j = -40^\circ\text{C}$ to 150°C

Parameter	Symbol	Limit Values		Unit	Conditions
		Min.	Max.		
Supply voltage	V_S	-18	18	V	for 1 h, $R_S \geq 200 \Omega$ for 5 min, $R_S \geq 200 \Omega$
		-18	24		
		-18	26		
Supply current through protection device	I_S	-50	50	mA	
Output voltage	V_Q	-0.7	18	V	for 5 min @ 1.2 k Ω pull up
		-0.7	26		
Continuous output current	I_Q	-50	50	mA	
Junction temperature	T_j	-	155	$^\circ\text{C}$	for 2000 h (not additive)
		-	165		for 1000 h (not additive)
		-	175		for 168 h (not additive)
		-	195		for 3 x 1 h (additive)
Storage temperature	T_S	-40	150	$^\circ\text{C}$	
Magnetic flux density	B	-	unlimited	mT	

Note: Stresses above those listed here may cause permanent damage to the device. Exposure to absolute maximum rating conditions for extended periods may affect device reliability.

Table 3 ESD Protection⁽¹⁾

Parameter	Symbol	Limit Values		Unit	Notes
		Min.	Max.		
ESD voltage	V_{ESD}	-	± 4	kV	HBM, $R = 1.5 \text{ k}\Omega$, $C = 100 \text{ pF}$ $T_A = 25^\circ\text{C}$

⁽¹⁾ Human Body Model (HBM) tests according to: EOS/ESD Association Standard S5.1-1993 and Mil. Std. 883D method 3015.7

4 Operating range

4 Operating range

Table 4 Operating range

Parameter	Symbol	Limit Values			Unit	Conditions
		Min.	Typ.	Max.		
Supply voltage	V_S	2.7	–	18	V	
		–	–	24		1 h with $R_S \geq 200 \Omega$
		–	–	26		for 5 min $R_S \geq 200 \Omega$
Output voltage	V_Q	-0.7	–	18	V	
Junction temperature	T_j	-40	–	150	°C	
		–	–	175		for 168 h
Output current	I_Q	0	–	10	mA	

5 Electrical and magnetic parameters

5 Electrical and magnetic parameters

Table 5 Electrical characteristics⁽¹⁾

Parameter	Symbol	Limit Values			Unit	Conditions
		Min.	Typ.	Max.		
Supply current	I_S	4	5.2	7	mA	$V_S = 2.7 \text{ V} \dots 18 \text{ V}$
Reverse current	I_{SR}	0	0.2	1	mA	$V_S = -18 \text{ V}$
Output saturation voltage	V_{QSAT}	-	0.3	0.6	V	$I_Q = 10 \text{ mA}$
Output leakage current	I_{QLEAK}	-	0.05	10	μA	for $V_Q = 18 \text{ V}$
Output fall time	t_f	-	0.2	1	μs	$R_L = 1.2 \text{ k}\Omega$; $C_L < 50 \text{ pF}$ see Figure 3
Output rise time	t_r	-	0.2	1		
Chopper frequency	f_{OSC}	-	320	-	kHz	
Switching frequency	f_{SW}	0	-	15 ⁽²⁾	kHz	
Delay time ⁽³⁾	t_d	-	13	-	μs	
Count Signal Delay	t_{dc}	50	200	1000	ns	
Output jitter ⁽⁴⁾	t_{QJ}	-	1	-	μs_{RMS}	Typ. value for squarewave signal 1 kHz
Repeatability of magnetic thresholds ⁽⁵⁾	B_{REP}	-	40	-	μT_{RMS}	Typ. value for $\Delta B / \Delta t > 12 \text{ mT/ms}$
Power-on time ⁽⁶⁾	t_{PON}	-	13	-	μs	$V_S \geq 2.7 \text{ V}$
Distance of hall plates	d_{HALL}	-	1.45		mm	
Thermal resistance ⁽⁷⁾	R_{thJA}	-	-	-190	K/W	PG-SSO-4-1

- (1) over operating range, unless otherwise specified. Typical values correspond to $V_S = 12 \text{ V}$ and $T_A = 25^\circ\text{C}$
- (2) To operate the sensor at the max. switching frequency, the magnetic signal amplitude must be 1.4 times higher than for static fields. This is due to the -3 dB corner frequency of the low pass filter in the signal path.
- (3) Systematic delay between magnetic threshold reached and output switching
- (4) Jitter is the unpredictable deviation of the output switching delay
- (5) BREP is equivalent to the noise constant
- (6) Time from applying $V_S \geq 2.7 \text{ V}$ to the sensor until the output state is valid
- (7) Thermal resistance from junction to ambient

Calculation of the ambient temperature:

e.g. for $V_S = 12.0 \text{ V}$, $I_{Styp} = 5.5 \text{ mA}$, $V_{QSATtyp} = 0.3 \text{ V}$ and $2 \times I_Q = 10 \text{ mA}$:
 Power Dissipation: $P_{DIS} = 72.0 \text{ mW}$.
 In $T_A = T_j - (R_{thJA} \times P_{DIS}) = 175^\circ\text{C} - (190 \text{ K/W} \times 0.072 \text{ W})$
 Resulting max. ambient temperature: $T_A = 161.3^\circ\text{C}$

5 Electrical and magnetic parameters

Table 6 **Magnetic characteristics⁽¹⁾**

Parameter	Symbol	T _j [°C]	Limit Values			Unit	Conditions
			Min.	Typ.	Max.		
Operate point	B _{OP}	-40	5.2	7.7	10.3	mT	
		25	5.0	7.5	10.0		
		150	4.7	7.1	9.5		
Release point	B _{RP}	-40	-10.3	-7.7	-5.2	mT	
		25	-10.0	-7.5	-5.0		
		150	-9.5	-7.1	-4.7		
Hysteresis	B _{HYS}	-40	-	-	-	mT	
		25	10.0	15.0	20.0		
		150	-	-	-		
Magnetic matching	B _{MATCH}	-40	-	-	-	mT	Valid for B _{OP1} - B _{OP2} and B _{RP1} - B _{RP2}
		25	-2.0	0	2.0		
		150	-	-	-		
Magnetic offset	B _{OFF}	-40	-	-	-	mT	(B _{OP} + B _{RP}) / 2
		25	-2.0	0	2.0		
		150	-	-	-		
Temperature compensation of magnetic thresholds	TC	-	-	-350	-	ppm/°C	

(1) over operating range, unless otherwise specified. Typical values correspond to V_S = 12 V

Note: *Typical characteristics specify mean values expected over the production spread*

Field Direction Definition

Positive magnetic fields related with south pole of magnet to the branded side of package.

6 Timing diagrams for the speed and direction

6 Timing diagrams for the speed and direction

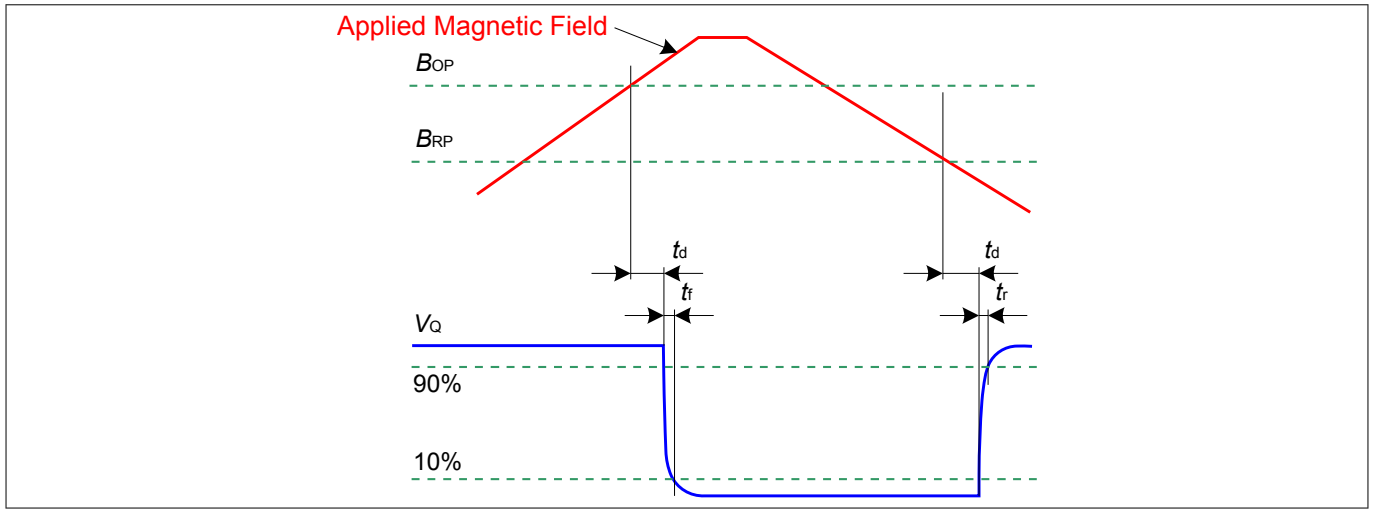

Figure 3 Timing definition of the speed signal

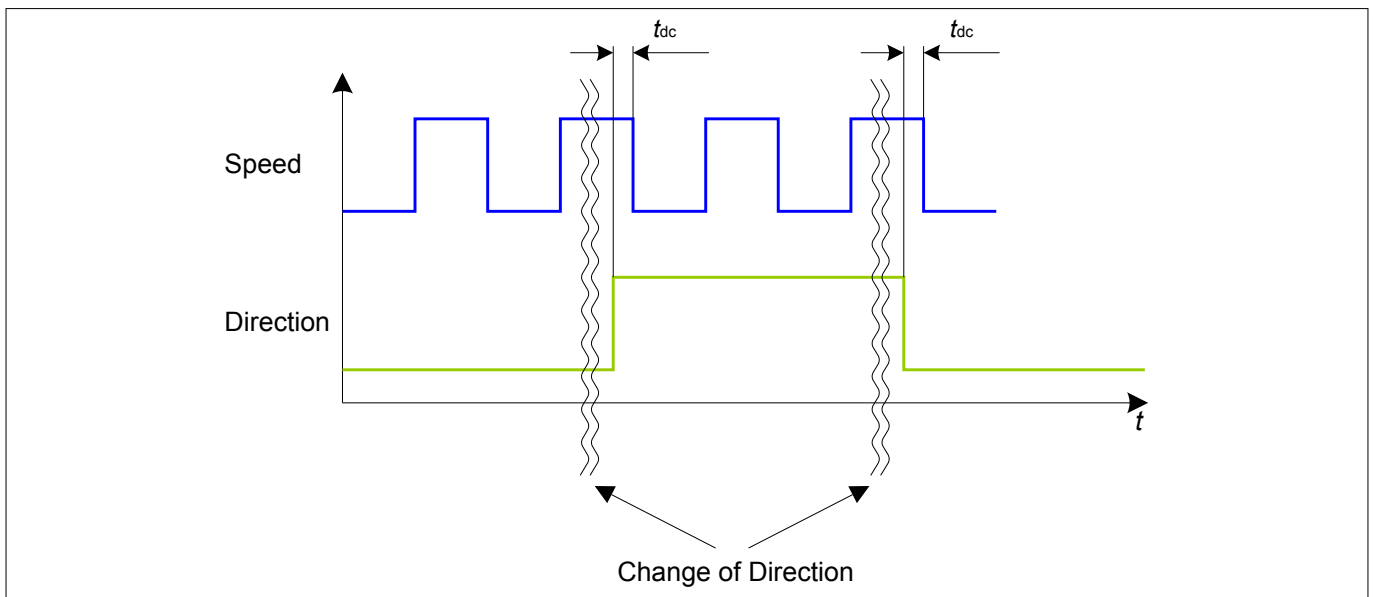

Figure 4 Timing definition of the direction signal

6 Timing diagrams for the speed and direction

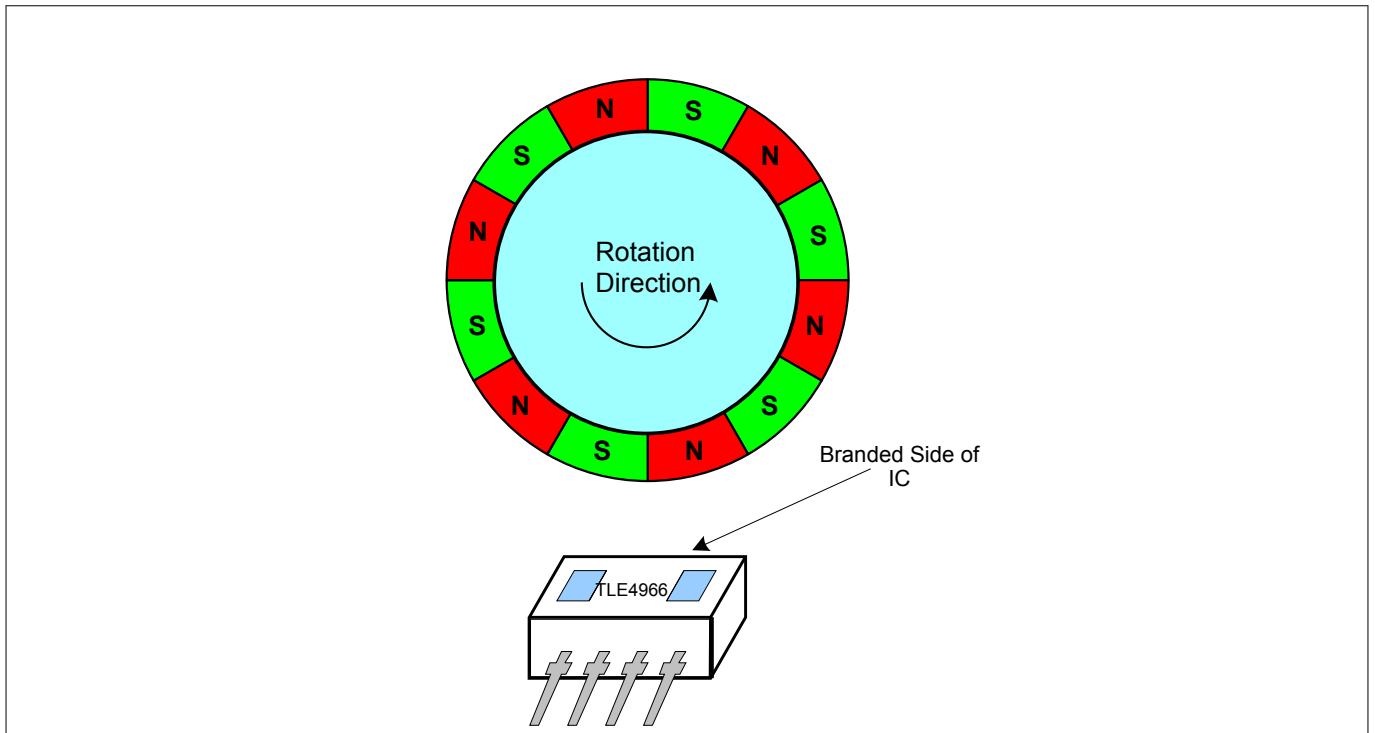

Figure 5 Definition of the direction signal

Rotation Direction	State of Direction Output V_{Q1}
Left to right	Low
Right to left	High

7 Package information

7 Package information

7.1 Package marking

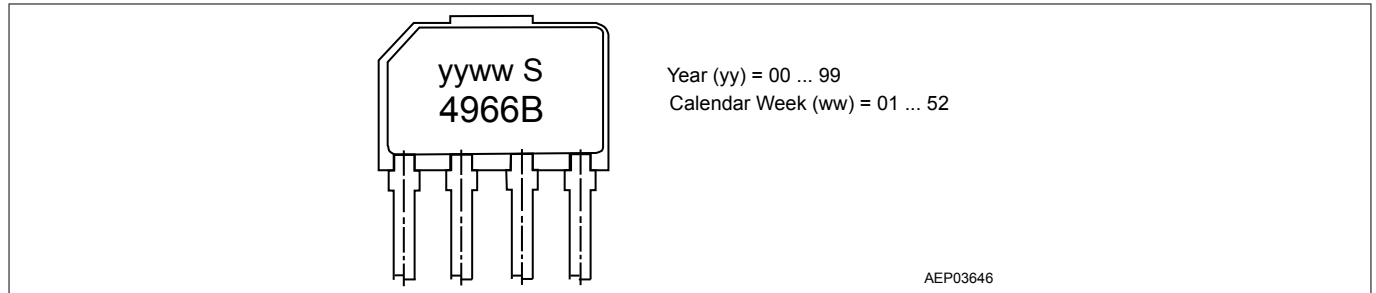

Figure 6 Marking

7.2 Distance between chip and package surface

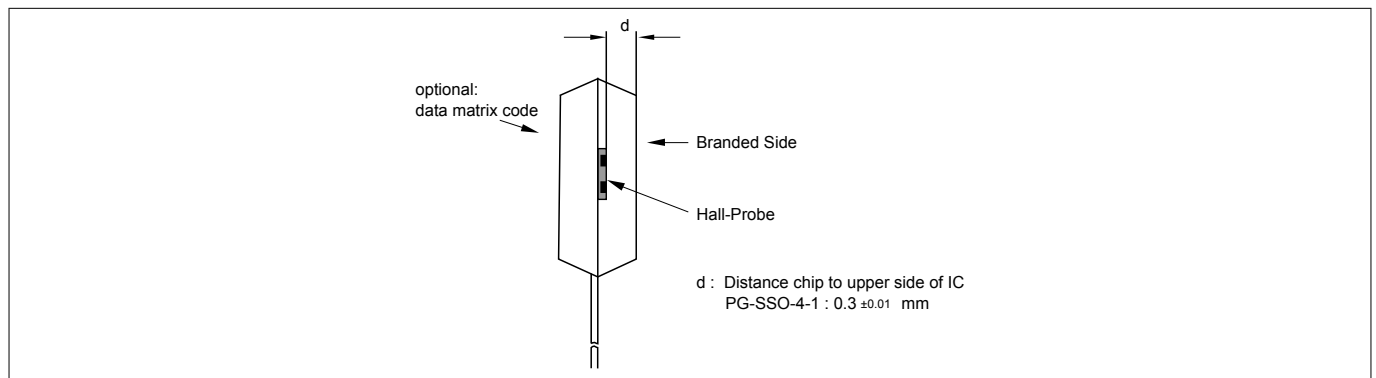

Figure 7 Distance chip to upper side of IC

8 Revision history

8 Revision history

Revision History

Page	Subjects (major changes since last revision)
-------------	---

Revision History: 2020-08, Rev. 2.1

Previous Revisions: Rev. 2.0

11	Edited figure 7 (optional: data matrix code)
----	--

Trademarks

All referenced product or service names and trademarks are the property of their respective owners.

Edition 2020-08

Published by

Infineon Technologies AG

81726 Munich, Germany

© 2020 Infineon Technologies AG

All Rights Reserved.

Do you have a question about any aspect of this document?

Email: erratum@infineon.com

Document reference

IFX-ipx1597828045356

IMPORTANT NOTICE

The information given in this document shall in no event be regarded as a guarantee of conditions or characteristics ("Beschaffheitsgarantie").

With respect to any examples, hints or any typical values stated herein and/or any information regarding the application of the product, Infineon Technologies hereby disclaims any and all warranties and liabilities of any kind, including without limitation warranties of non-infringement of intellectual property rights of any third party.

In addition, any information given in this document is subject to customer's compliance with its obligations stated in this document and any applicable legal requirements, norms and standards concerning customer's products and any use of the product of Infineon Technologies in customer's applications.

The data contained in this document is exclusively intended for technically trained staff. It is the responsibility of customer's technical departments to evaluate the suitability of the product for the intended application and the completeness of the product information given in this document with respect to such application.

WARNINGS

Due to technical requirements products may contain dangerous substances. For information on the types in question please contact your nearest Infineon Technologies office.

Except as otherwise explicitly approved by Infineon Technologies in a written document signed by authorized representatives of Infineon Technologies, Infineon Technologies' products may not be used in any applications where a failure of the product or any consequences of the use thereof can reasonably be expected to result in personal injury.

X-ON Electronics

Largest Supplier of Electrical and Electronic Components

Click to view similar products for [Board Mount Hall Effect/Magnetic Sensors](#) category:

Click to view products by [Infineon](#) manufacturer:

Other Similar products are found below :

[HGPRDT005A](#) [AH1808-P-A](#) [AH277AZ4-AG1](#) [AV-10379](#) [AV-10448](#) [SS41C](#) [AH1894-Z-7](#) [ATS601LSGTN-HT-WU4-T](#) [ATS601LSGTN-LT-WU4-T](#) [TLE4917](#) [50017859-003](#) [TY-13101](#) [SS85CA](#) [AH277AZ4-BG1](#) [TLE49614MXTSA1](#) [AH3382-P-B](#) [AH3377-P-B](#) [AH9250-W-7](#) [AH211Z4-AG1](#) [AH3360-FT4-7](#) [SS460S-100SAMPLE](#) [50065820-03](#) [TLE4941PLUSCB](#) [AH374-P-A](#) [AH1806-P-A](#) [AH374-W-7](#) [SS460P-T2](#) [AH1912-FA-7](#) [SS413F](#) [TLE5046ICAKLRHALA1](#) [TLE49421CHAMA2](#) [TLE4941PLUSCXAMA1](#) [AH1912-W-EVM](#) [AH1903-FA-EVM](#) [AH3774-W-EVM](#) [AH49FNTR-EVM](#) [MMC5633NJL](#) [AH3360-FA-EVM](#) [AH8502-FDC-EVM](#) [AH3366Q-SA-EVM](#) [AH3774-P-EVM](#) [KTH1601SU-ST3](#) [MG910](#) [MG910M](#) [MG911](#) [MG610](#) [MW921](#) [MW922](#) [TLE4998S3XALA1](#) [TLE5011FUMA1](#)