

TLE6250

High Speed CAN-Transceiver



Features

- CAN data transmission rate up to 1 Mbit/s
- Receive-only mode and Stand-by mode
- Suitable for 12 V and 24 V applications
- Excellent EMC performance (very high immunity and very low emission)
- Versions for 5 V and 3.3 V microcontrollers
- Bus pins are short circuit proof to ground and battery voltage
- Overtemperature protection
- Very wide temperature range (-40°C up to 150°C)
- Green Product (RoHS compliant)

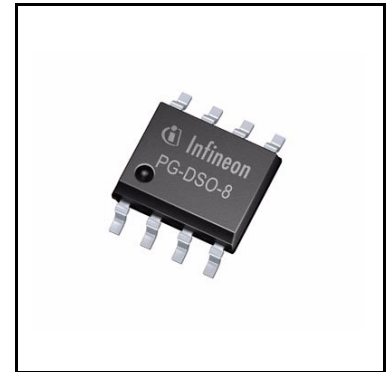

Potential applications

- Engine control unit (ECUs)
- Transmission control units (TCUs)
- Chassis control modules
- Electric power steering

Product validation

Qualified for automotive applications. Product validation according to AEC-Q100.

Description

The HS CAN-transceivers of the TLE6250 family are monolithic integrated circuits that are available as bare die as well as in a PG-DSO-8 package with the same functionality. The transceivers are optimized for high speed differential mode data transmission in automotive applications and industrial applications and they are compatible to ISO 11898. The transceivers work as an interface between the CAN protocol controller and the physical differential bus in both 12 V systems and 24 V systems.

The transceivers are based on the Smart Power Technology (SPT), which allows bipolar and CMOS control circuitry in accordance with DMOS power devices to coexist in the monolithic circuit. The TLE6250 is designed to withstand the severe conditions of automotive applications and provides excellent EMC performance.

TLE6250G

5 V logic I/O version: RxD, TxD, INH, RM. Two control pins (RM, INH) and three operation modes: Normal mode, Stand-by mode and Receive-only mode.

The functions and parameters of the TLE6250G and TLE6250C are identical, except those related to the package. In this document the content for TLE6250G also applies to TLE6250C, unless otherwise stated.

TLE6250GV33

3.3 V logic I/O version (logic I/O voltage adaptive to V_{33V} pin in the range of 3.3 V to 5 V): RxD, TxD, INH. One control pin (INH) and two operation modes: Normal mode and Standby mode.

The functions and parameters of the TLE6250GV33 and TLE6250CV33 are identical, except those related to the package. In this document the content for TLE6250GV33 also applies to TLE6250CV33, unless otherwise stated.

Type	Package	Marking
TLE6250G	PG-DSO-8	TLE6250
TLE6250C	(chip)	–
TLE6250GV33	PG-DSO-8	TLE6250V33
TLE6250CV33	(chip)	–

Table of contents

	Features	1
	Potential applications	1
	Product validation	1
	Description	1
	Table of contents	3
1	Block diagram	4
2	Pin configuration	5
3	General product characteristics and electrical characteristics	7
3.1	General product characteristics TLE6250G (5 V version)	7
3.2	Electrical characteristics TLE6250G (5 V version)	8
3.3	General product characteristics TLE6250GV33 (3.3 V version)	12
3.4	Electrical characteristics TLE6250GV33 (3.3 V version)	13
4	Diagrams	16
5	Application information	19
6	Package outlines	22
7	Revision history	23

Block diagram

1 Block diagram

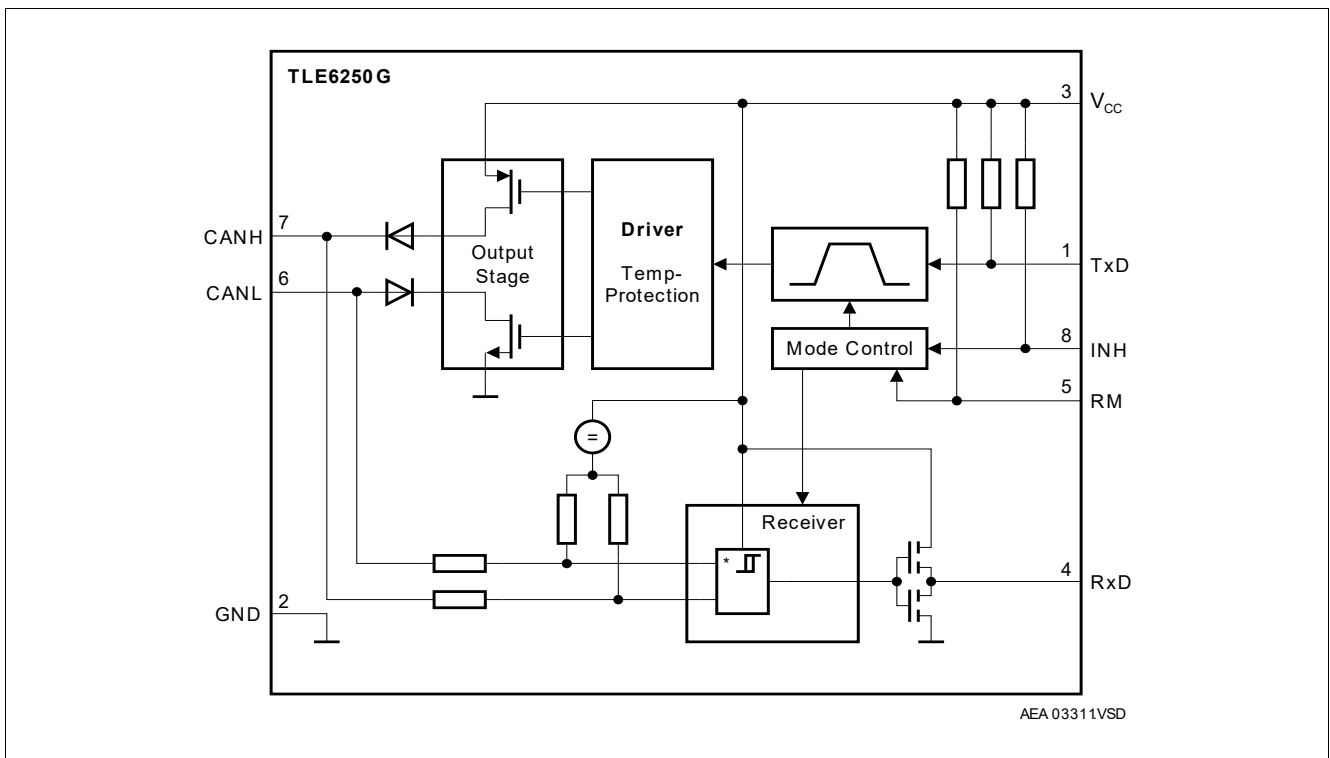

Figure 1 Block diagram TLE6250G

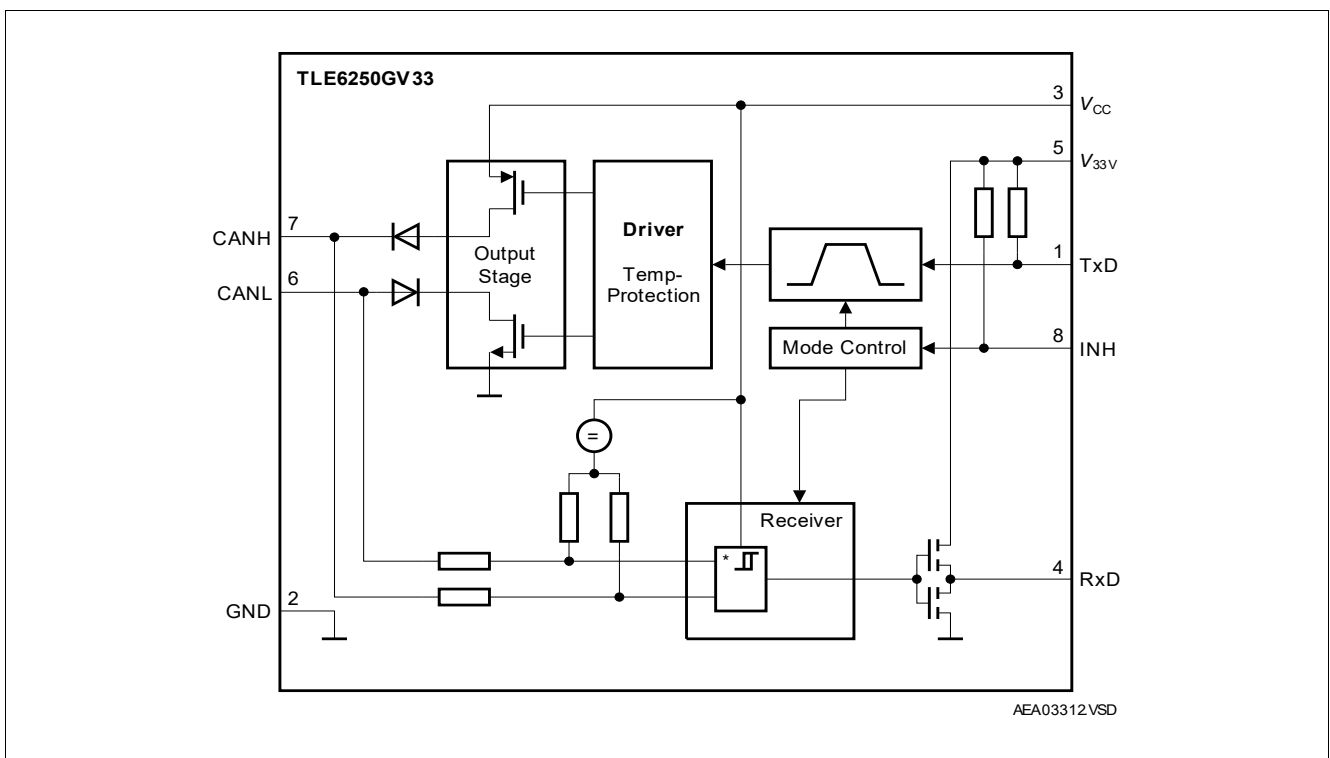

Figure 2 Block diagram TLE6250GV33

Pin configuration

2 Pin configuration

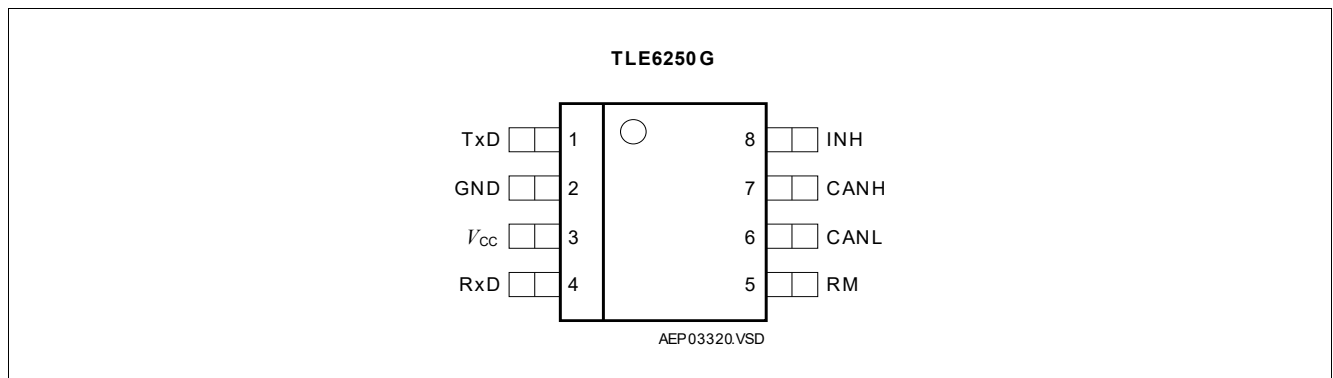

Figure 3 Pin configuration TLE6250G (top view)

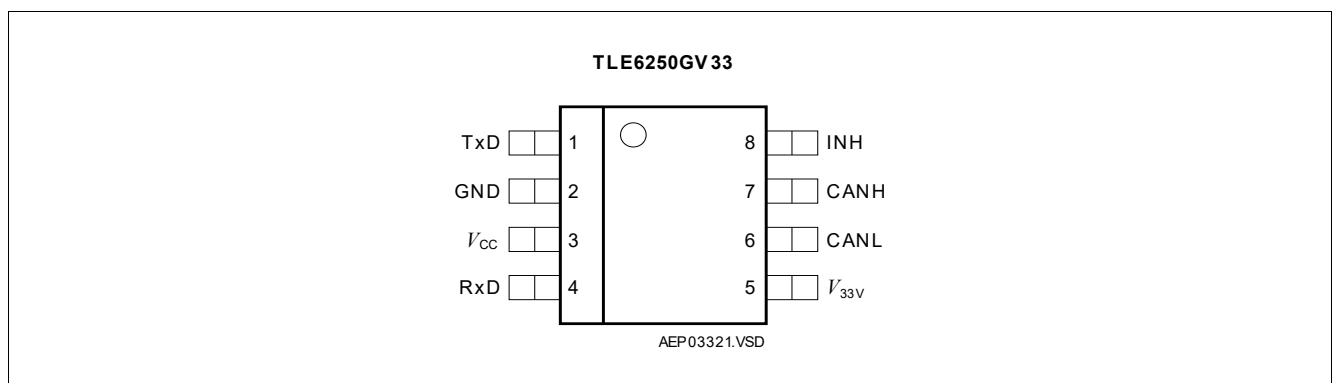

Figure 4 Pin configuration TLE6250GV33 (top view)

Table 1 Pin definitions and functions TLE6250G

Pin No.	Symbol	Function
1	TxD	CAN transmit data input 20 kΩ pull-up, “low” in dominant state.
2	GND	Ground
3	V _{CC}	5 V supply input
4	RxD	CAN receive data output “Low” in dominant state, integrated pull-up.
5	RM	Receive-only input Control input, 20 kΩ pull-up, set to “low” for entering receive-only mode.
6	CANL	Low line I/O “Low” in dominant state.
7	CANH	High line I/O “High” in dominant state.
8	INH	Inhibit input Control input, 20 kΩ pull-up, set to “low” for entering normal mode.

Pin configuration

Table 2 Pin definitions and functions TLE6250GV33

Pin No.	Symbol	Function
1	TxD	CAN transmit data input 20 kΩ pull-up, “low” in dominant state.
2	GND	Ground
3	V _{CC}	5 V supply input
4	RxD	CAN receive data output “Low” in dominant state, integrated pull-up.
5	V _{33V}	Logic supply input; 3.3 V or 5 V The microcontroller logic supply can be connected to this pin. The TLE6250GV33 adapts the digital I/Os to the connected microcontroller logic supply at V _{33V} .
6	CANL	Low line I/O “Low” in dominant state.
7	CANH	High line I/O “High” in dominant state.
8	INH	Inhibit input Control input, 20 kΩ pull-up, set to “low” for entering normal mode.

General product characteristics and electrical characteristics

3 General product characteristics and electrical characteristics

3.1 General product characteristics TLE6250G (5 V version)

Table 3 Absolute maximum ratings TLE6250G (5 V version)

Parameter	Symbol	Values			Unit	Note or Test Condition
		Min.	Typ.	Max.		
Voltages						
Supply voltage	V_{CC}	-0.3	-	6.5	V	-
CAN Input voltage (CANH, CANL)	$V_{CANH/L}$	-40	-	40	V	-
Logic voltages at INH, RM, TxD, RxD	V_I	-0.3	-	V_{CC}	V	$0\text{ V} < V_{CC} < 5.5\text{ V}$
Electrostatic discharge voltage at CANH, CANL	V_{ESD}	-6	-	6	kV	Human body model (100 pF via 1.5 k Ω)
Electrostatic discharge voltage	V_{ESD}	-2	-	2	kV	Human body model (100 pF via 1.5 k Ω)
Temperatures						
Junction temperature	T_j	-40	-	160	$^{\circ}\text{C}$	-

Note: Maximum ratings are absolute ratings; exceeding any one of these values may cause irreversible damage to the integrated circuit.

Table 4 Operating range TLE6250G (5 V version)

Parameter	Symbol	Values			Unit	Note or Test Condition
		Min.	Typ.	Max.		
Voltages						
Supply voltage	V_{CC}	4.5	-	5.5	V	-
Junction temperature	T_j	-40	-	150	$^{\circ}\text{C}$	-
Thermal resistance						
Junction ambient	R_{thj-a}	-	-	185	K/W	In PG-DSO-8 package
Thermal shutdown (junction temperature)						
Thermal shutdown temperature	T_{jSD}	160	-	200	$^{\circ}\text{C}$	¹⁾ 10 $^{\circ}\text{C}$ hysteresis

1) Not subject to production test, specified by design.

General product characteristics and electrical characteristics

3.2 Electrical characteristics TLE6250G (5 V version)

Table 5 Electrical characteristics TLE6250G (5 V version)

4.5 V < V_{CC} < 5.5 V; $R_L = 60 \Omega$; $V_{INH} < V_{INH,ON}$; $-40^\circ\text{C} < T_j < 150^\circ\text{C}$; all voltages with respect to ground; positive current flowing into pin; unless otherwise specified.

Parameter	Symbol	Values			Unit	Note or Test Condition
		Min.	Typ.	Max.		
Current consumption						
Current consumption	I_{CC}	–	6	10	mA	Recessive state; $V_{TxD} = V_{CC}$
Current consumption	I_{CC}	–	45	70	mA	Dominant state; $V_{TxD} = 0 \text{ V}$
Current consumption	I_{CC}	–	6	10	mA	Receive-only mode; RM = “low”
Current consumption	$I_{CC,STB}$	–	1	10	μA	Stand-by mode; TxD = RM = “high”
Receiver output RxD						
“High” output current	$I_{RD,H}$	–	-4	-2	mA	$V_{RD} = 0.8 \times V_{CC}$; $V_{diff} < 0.4 \text{ V}^{1)}$
“Low” output current	$I_{RD,L}$	2	4	–	mA	$V_{RD} = 0.2 \times V_{CC}$; $V_{diff} > 1 \text{ V}^{1)}$
Transmission input TxD						
“High” input voltage threshold	$V_{TD,H}$	–	$0.5 \times V_{CC}$	$0.7 \times V_{CC}$	V	Recessive state
“Low” input voltage threshold	$V_{TD,L}$	$0.3 \times V_{CC}$	$0.4 \times V_{CC}$	–	V	Dominant state
TxD pull-up resistance	R_{TD}	10	25	50	k Ω	–
Inhibit input (INH pin)						
“High” input voltage threshold	$V_{INH,H}$	–	$0.5 \times V_{CC}$	$0.7 \times V_{CC}$	V	Stand-by mode
“Low” input voltage threshold	$V_{INH,L}$	$0.3 \times V_{CC}$	$0.4 \times V_{CC}$	–	V	Normal mode
INH pull-up resistance	R_{INH}	10	25	50	k Ω	–

General product characteristics and electrical characteristics

Table 5 Electrical characteristics TLE6250G (5 V version) (cont'd)

$4.5\text{ V} < V_{CC} < 5.5\text{ V}$; $R_L = 60\ \Omega$; $V_{INH} < V_{INH,ON}$; $-40^\circ\text{C} < T_j < 150^\circ\text{C}$; all voltages with respect to ground; positive current flowing into pin; unless otherwise specified.

Parameter	Symbol	Values			Unit	Note or Test Condition
		Min.	Typ.	Max.		
Receive only input (RM pin) (5 V version)						
“High” input voltage threshold	$V_{RM,H}$	–	$0.5 \times V_{CC}$	$0.7 \times V_{CC}$	V	Normal mode
“Low” input voltage threshold	$V_{RM,L}$	$0.3 \times V_{CC}$	$0.4 \times V_{CC}$	–	V	Receive-only mode
RM pull-up resistance	R_{RM}	10	25	50	k Ω	–
Bus receiver						
Differential receiver threshold voltage, recessive to dominant edge	$V_{diff,d}$	–	0.75	0.90	V	$-20\text{ V} < (V_{CANH}, V_{CANL}) < 25\text{ V}$; $V_{diff} = V_{CANH} - V_{CANL}$
Differential receiver threshold voltage dominant to recessive edge	$V_{diff,r}$	0.50	0.60	–	V	$-20\text{ V} < (V_{CANH}, V_{CANL}) < 25\text{ V}$; $V_{diff} = V_{CANH} - V_{CANL}$
Common mode range	CMR	-20	–	25	V	$V_{CC} = 5\text{ V}$
Differential receiver hysteresis	$V_{diff,hys}$	–	150	–	mV	–
CANH, CANL input resistance	R_i	10	20	30	k Ω	Recessive state
Differential input resistance	R_{diff}	20	40	60	k Ω	Recessive state

General product characteristics and electrical characteristics

Table 5 Electrical characteristics TLE6250G (5 V version) (cont'd)

4.5 V < V_{CC} < 5.5 V; $R_L = 60 \Omega$; $V_{INH} < V_{INH,ON}$; $-40^\circ\text{C} < T_j < 150^\circ\text{C}$; all voltages with respect to ground; positive current flowing into pin; unless otherwise specified.

Parameter	Symbol	Values			Unit	Note or Test Condition
		Min.	Typ.	Max.		
Bus transmitter						
CANL/CANH recessive output voltage	$V_{CANL/H}$	$0.4 \times V_{CC}$	–	$0.6 \times V_{CC}$	V	$V_{TxD} = V_{CC}$
CANH, CANL recessive output voltage difference $V_{diff} = V_{CANH} - V_{CANL}$, no load ²⁾	V_{diff}	-1	–	0.05	V	$V_{TxD} = V_{CC}$
CANL dominant output voltage	V_{CANL}	–	–	2.0	V	$V_{TxD} = 0 \text{ V};$ $V_{CC} = 5 \text{ V}$
CANH dominant output voltage	V_{CANH}	2.8	–	–	V	$V_{TxD} = 0 \text{ V};$ $V_{CC} = 5 \text{ V}$
CANH, CANL dominant output voltage difference $V_{diff} = V_{CANH} - V_{CANL}$	V_{diff}	1.5	–	3.0	V	$V_{TxD} = 0 \text{ V};$ $V_{CC} = 5 \text{ V}$
CANL short circuit current	I_{CANLsc}	50	120	200	mA	$V_{CANLshort} = 18 \text{ V}$
CANL short circuit current	I_{CANLsc}	–	150	–	mA	$V_{CANLshort} = 36 \text{ V}$
CANH short circuit current	I_{CANHsc}	-200	-120	-50	mA	$V_{CANHshort} = 0 \text{ V}$
CANH short circuit current	I_{CANHsc}	–	-120	–	mA	$V_{CANHshort} = -5 \text{ V}$
Output current	$I_{CANH,Ik}$	-50	-300	-400	μA	$V_{CC} = 0 \text{ V};$ $V_{CANH} = V_{CANL} = -7 \text{ V}$
Output current	$I_{CANH,Ik}$	-50	-100	-150	μA	$V_{CC} = 0 \text{ V};$ $V_{CANH} = V_{CANL} = -2 \text{ V}$
Output current	$I_{CANH,Ik}$	50	280	400	μA	$V_{CC} = 0 \text{ V};$ $V_{CANH} = V_{CANL} = 7 \text{ V}$
Output current	$I_{CANH,Ik}$	50	100	150	μA	$V_{CC} = 0 \text{ V};$ $V_{CANH} = V_{CANL} = 2 \text{ V}$

General product characteristics and electrical characteristics

Table 5 Electrical characteristics TLE6250G (5 V version) (cont'd)

4.5 V < V_{CC} < 5.5 V; $R_L = 60 \Omega$; $V_{INH} < V_{INH,ON}$; $-40^\circ\text{C} < T_j < 150^\circ\text{C}$; all voltages with respect to ground; positive current flowing into pin; unless otherwise specified.

Parameter	Symbol	Values			Unit	Note or Test Condition
		Min.	Typ.	Max.		
Dynamic CAN-transceiver characteristics						
Propagation delay TxD-to-RxD “low” (recessive to dominant)	$t_{d(L),TR}$	–	150	255	ns	³⁾ $C_L = 47 \text{ pF}$; $R_L = 60 \Omega$; $V_{CC} = 5 \text{ V}$; $C_{RXD} = 20 \text{ pF}$
Propagation delay TxD-to-RxD “high” (dominant to recessive)	$t_{d(H),TR}$	–	150	255	ns	³⁾ $C_L = 47 \text{ pF}$; $R_L = 60 \Omega$; $V_{CC} = 5 \text{ V}$; $C_{RXD} = 20 \text{ pF}$
Propagation delay TxD “low” to bus dominant	$t_{d(L),T}$	–	100	140	ns	$C_L = 47 \text{ pF}$; $R_L = 60 \Omega$; $V_{CC} = 5 \text{ V}$
Propagation delay TxD “high” to bus recessive	$t_{d(H),T}$	–	100	140	ns	$C_L = 47 \text{ pF}$; $R_L = 60 \Omega$; $V_{CC} = 5 \text{ V}$
Propagation delay bus dominant to RxD “low”	$t_{d(L),R}$	–	50	140	ns	$C_L = 47 \text{ pF}$; $R_L = 60 \Omega$; $V_{CC} = 5 \text{ V}$; $C_{RXD} = 20 \text{ pF}$
Propagation delay bus recessive to RxD “high”	$t_{d(H),R}$	–	50	140	ns	$C_L = 47 \text{ pF}$; $R_L = 60 \Omega$; $V_{CC} = 5 \text{ V}$; $C_{RXD} = 20 \text{ pF}$

1) $V_{diff} = V_{CANH} - V_{CANL}$.

2) Deviation from ISO 11898.

3) TLE6250C: Not subject to production test, specified by design.

General product characteristics and electrical characteristics

3.3 General product characteristics TLE6250GV33 (3.3 V version)

Table 6 Absolute maximum ratings TLE6250GV33 (3.3 V version)

Parameter	Symbol	Values			Unit	Note or Test Condition
		Min.	Typ.	Max.		
Voltages						
Supply voltage	V_{CC}	-0.3	–	6.5	V	–
3.3 V supply	V_{33V}	-0.3	–	6.5	V	–
CAN input voltage (CANH, CANL)	$V_{CANH/L}$	-40	–	40	V	–
Logic voltages at INH, RM, TxD, RxD	V_I	-0.3	–	V_{CC}	V	$0 V < V_{CC} < 5.5 V$
Electrostatic discharge voltage at CANH, CANL	V_{ESD}	-6	–	6	kV	Human body model (100 pF via 1.5 k Ω)
Electrostatic discharge voltage	V_{ESD}	-2	–	2	kV	Human body model (100 pF via 1.5 k Ω)
Temperatures						
Junction temperature	T_j	-40	–	160	°C	–

Note: Maximum ratings are absolute ratings; exceeding any one of these values may cause irreversible damage to the integrated circuit.

Table 7 Operating range TLE6250GV33 (3.3 V version)

Parameter	Symbol	Values			Unit	Note or Test Condition
		Min.	Typ.	Max.		
Supply voltage	V_{CC}	4.5	–	5.5	V	–
3.3 V supply voltage	V_{33V}	3.0	–	5.5	V	–
Junction temperature	T_j	-40	–	150	°C	–

Thermal resistance

Junction ambient	R_{thj-a}	–	–	185	K/W	In PG-DSO-8 package
------------------	-------------	---	---	-----	-----	---------------------

Thermal shutdown (junction temperature)

Thermal shutdown temperature	T_{jSD}	160	–	200	°C	¹⁾ 10°C hysteresis
------------------------------	-----------	-----	---	-----	----	-------------------------------

1) Not subject to production test, specified by design.

General product characteristics and electrical characteristics

3.4 Electrical characteristics TLE6250GV33 (3.3 V version)

Table 8 Electrical characteristics TLE6250GV33 (3.3 V version)

4.5 V < V_{CC} < 5.5 V; (3.0 V < V_{33V} < 5.5 V for 3.3 V version); R_L = 60 Ω; V_{INH} < V_{INH,ON}; -40°C < T_j < 150°C; all voltages with respect to ground; positive current flowing into pin; unless otherwise specified.

Parameter	Symbol	Values			Unit	Note or Test Condition
		Min.	Typ.	Max.		
Current consumption (3.3 V version)						
Current consumption	I _{CC+33V}	–	6	10	mA	Recessive state; V _{TxD} = V _{33V}
Current consumption	I _{CC+33V}	–	45	70	mA	Dominant state; V _{TxD} = 0 V
Current consumption	I _{33V}	–	–	2	mA	–
Current consumption	I _{CC+33V, stb}	–	1	10	μA	Stand-by mode; TxD = “high”
Receiver output RxD						
“High” output current	I _{RD,H}	–	-2	-1	mA	V _{RD} = 0.8 × V _{33V} ; V _{diff} < 0.4 V ¹⁾
“Low” output current	I _{RD,L}	1	2	–	mA	V _{RD} = 0.2 × V _{33V} ; V _{diff} > 1 V ¹⁾
Transmission input TxD						
“High” input voltage threshold	V _{TD,H}	–	0.55 × V _{33V}	0.7 × V _{33V}	V	Recessive state
“Low” input voltage threshold	V _{TD,L}	0.3 × V _{33V}	0.45 × V _{33V}	–	V	Dominant state
TxD pull-up resistance	R _{TD}	10	25	50	kΩ	–
Inhibit Input (pin INH)						
“High” input voltage threshold	V _{INH,H}	–	0.55 × V _{33V}	0.7 × V _{33V}	V	Stand-by mode
“Low” input voltage threshold	V _{INH,L}	0.3 × V _{33V}	0.45 × V _{33V}	–	V	Normal mode
INH pull-up resistance	R _{INH}	10	25	50	kΩ	–
Bus receiver						
Differential receiver threshold voltage, recessive to dominant edge	V _{diff,d}	–	0.75	0.90	V	-20 V < (V _{CANH} , V _{CANL}) < 25 V; V _{diff} = V _{CANH} - V _{CANL}
Differential receiver threshold voltage, dominant to recessive edge	V _{diff,r}	0.50	0.60	–	V	-20 V < (V _{CANH} , V _{CANL}) < 25 V; V _{diff} = V _{CANH} - V _{CANL}
Common mode range	CMR	-20	–	25	V	V _{CC} = 5 V
Differential receiver hysteresis	V _{diff,hys}	–	150	–	mV	–
CANH, CANL input resistance	R _i	10	20	30	kΩ	Recessive state
Differential input resistance	R _{diff}	20	40	60	kΩ	Recessive state

General product characteristics and electrical characteristics

Table 8 Electrical characteristics TLE6250GV33 (3.3 V version) (cont'd)

4.5 V < V_{CC} < 5.5 V; (3.0 V < V_{33V} < 5.5 V for 3.3 V version); R_L = 60 Ω; V_{INH} < V_{INH,ON}; -40°C < T_j < 150°C; all voltages with respect to ground; positive current flowing into pin; unless otherwise specified.

Parameter	Symbol	Values			Unit	Note or Test Condition
		Min.	Typ.	Max.		
Bus transmitter						
CANL/CANH recessive output voltage	V _{CANL/H}	0.4 × V _{CC}	–	0.6 × V _{CC}	V	V _{TxD} = V _{33V}
CANH, CANL recessive output voltage difference V _{diff} = V _{CANH} - V _{CANL} , no load ²⁾	V _{diff}	-1	–	0.05	V	V _{TxD} = V _{33V}
CANL dominant output voltage	V _{CANL}	–	–	2.0	V	V _{TxD} = 0 V; V _{CC} = 5 V
CANH dominant output voltage	V _{CANH}	2.8	–	–	V	V _{TxD} = 0 ; V _{CC} = 5 V
CANH, CANL dominant output voltage difference V _{diff} = V _{CANH} - V _{CANL}	V _{diff}	1.5	–	3.0	V	V _{TxD} = 0 V; V _{CC} = 5 V
CANL short circuit current	I _{CANLsc}	50	120	200	mA	V _{CANLshort} = 18 V
CANL short circuit current	I _{CANLsc}	–	150	–	mA	V _{CANLshort} = 36 V
CANH short circuit current	I _{CANHsc}	-200	-120	-50	mA	V _{CANHshort} = 0 V
CANH short circuit current	I _{CANHsc}	–	-120	–	mA	V _{CANHshort} = -5 V
Output current	I _{CANH/L,lk}	-50	-300	-400	μA	V _{CC} = 0 V; V _{CANH} = V _{CANL} = -7 V
Output current	I _{CANH/L,lk}	-50	-100	-150	μA	V _{CC} = 0 V; V _{CANH} = V _{CANL} = -2 V
Output current	I _{CANH/L,lk}	50	280	400	μA	V _{CC} = 0 V; V _{CANH} = V _{CANL} = 7 V
Output current	I _{CANH/L,lk}	50	100	150	μA	V _{CC} = 0 V; V _{CANH} = V _{CANL} = 2 V

General product characteristics and electrical characteristics

Table 8 Electrical characteristics TLE6250GV33 (3.3 V version) (cont'd)

4.5 V < V_{CC} < 5.5 V; (3.0 V < V_{33V} < 5.5 V for 3.3 V version); R_L = 60 Ω; V_{INH} < V_{INH,ON}; -40°C < T_j < 150°C; all voltages with respect to ground; positive current flowing into pin; unless otherwise specified.

Parameter	Symbol	Values			Unit	Note or Test Condition
		Min.	Typ.	Max.		
Dynamic CAN-transceiver characteristics						
Propagation delay TxD-to-RxD “low” (recessive to dominant)	t _{d(L),TR}	–	150	255	ns	³⁾ C _L = 47 pF; R _L = 60 Ω; V _{CC} = 5 V; C _{RxD} = 20 pF
Propagation delay TxD-to-RxD “high” (dominant to recessive)	t _{d(H),TR}	–	150	255	ns	³⁾ C _L = 47 pF; R _L = 60 Ω; V _{CC} = 5 V; C _{RxD} = 20 pF
Propagation delay TxD “low” to bus dominant	t _{d(L),T}	–	100	140	ns	C _L = 47 pF; R _L = 60 Ω; V _{CC} = 5 V
Propagation delay TxD “high” to bus recessive	t _{d(H),T}	–	100	140	ns	C _L = 47 pF; R _L = 60 Ω; V _{CC} = 5 V
Propagation delay bus dominant to RxD “low”	t _{d(L),R}	–	50	140	ns	C _L = 47 ; R _L = 60 Ω; V _{CC} = 5 V; C _{RxD} = 20 pF
Propagation delay bus recessive to RxD “high”	t _{d(H),R}	–	50	140	ns	C _L = 47 pF; R _L = 60 Ω; V _{CC} = 5 V; C _{RxD} = 20 pF

1) V_{diff} = V_{CANH} - V_{CANL}.

2) Deviation from ISO 11898.

3) TLE6250CV33: Not subject to production test, specified by design.

Diagrams

4 Diagrams

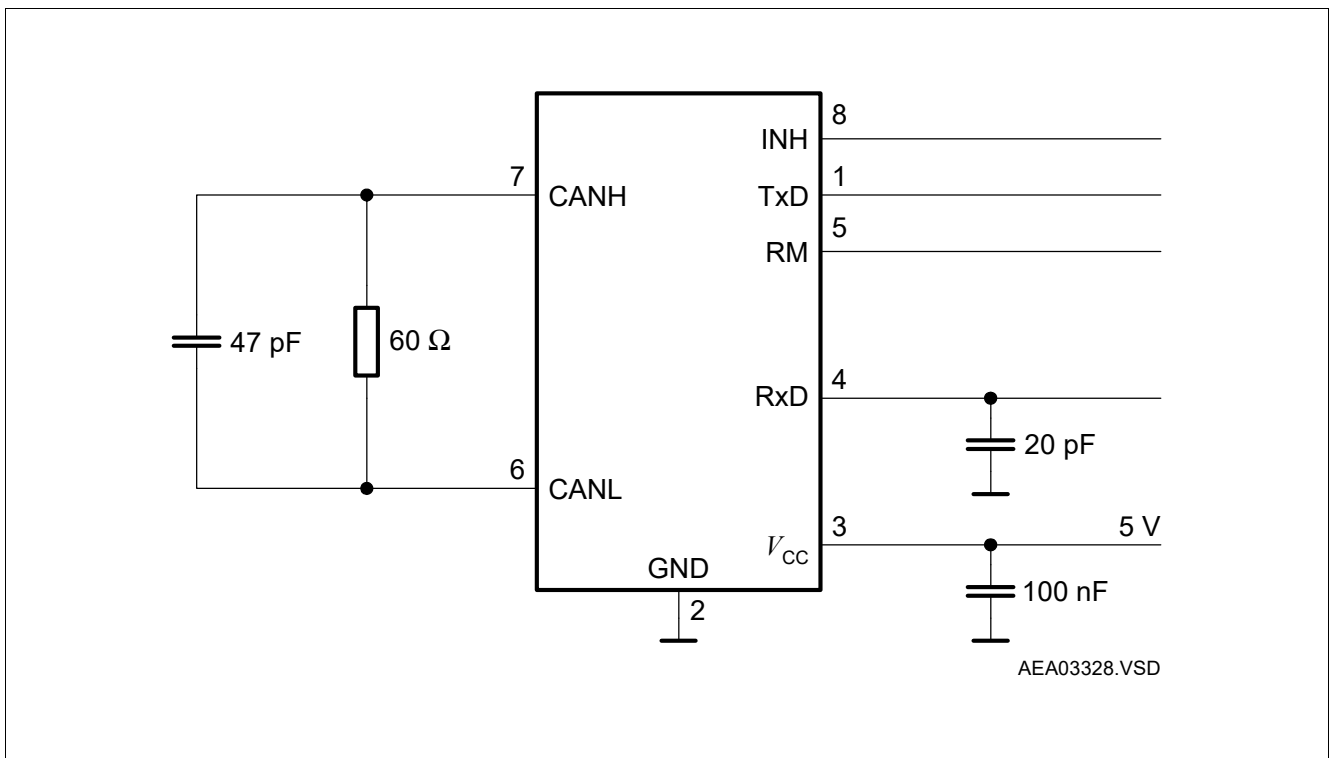

Figure 5 Test circuit for dynamic characteristics (5 V version)

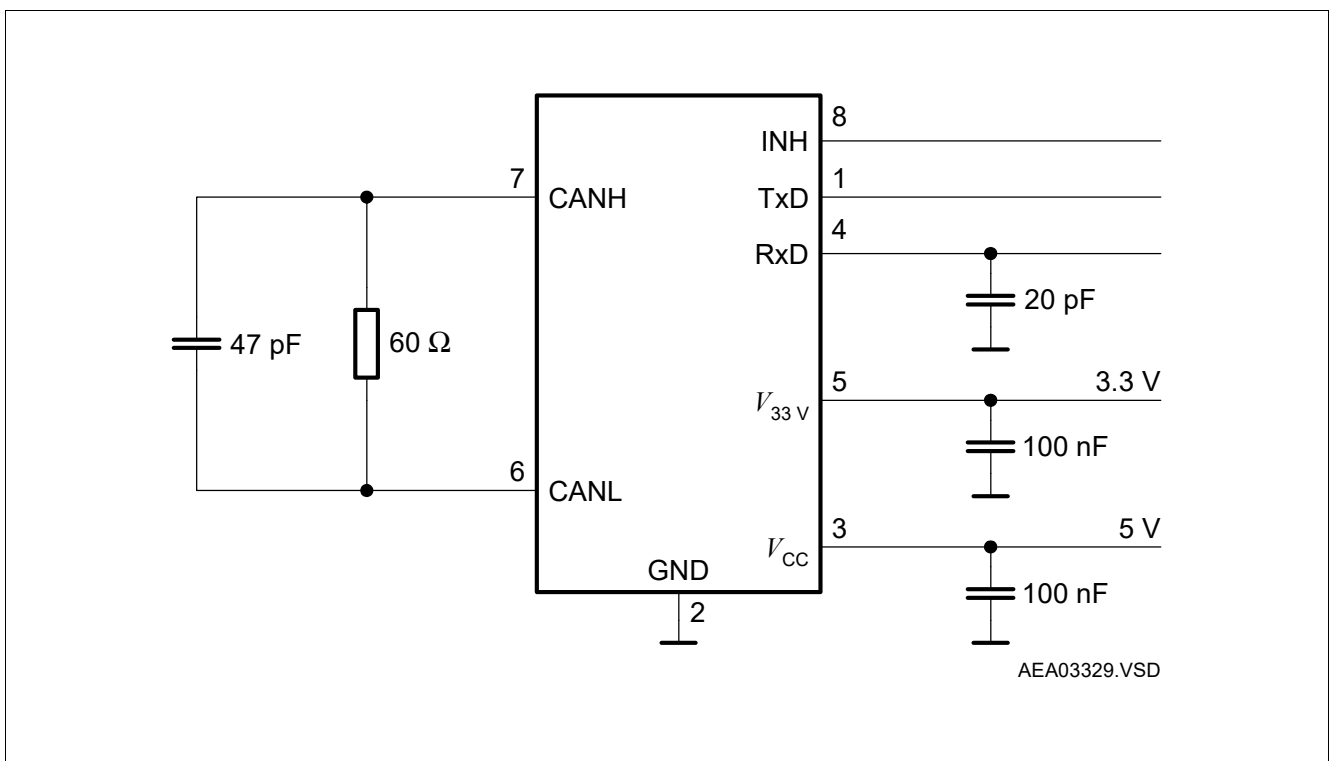

Figure 6 Test circuit for dynamic characteristics (3.3 V version)

Diagrams

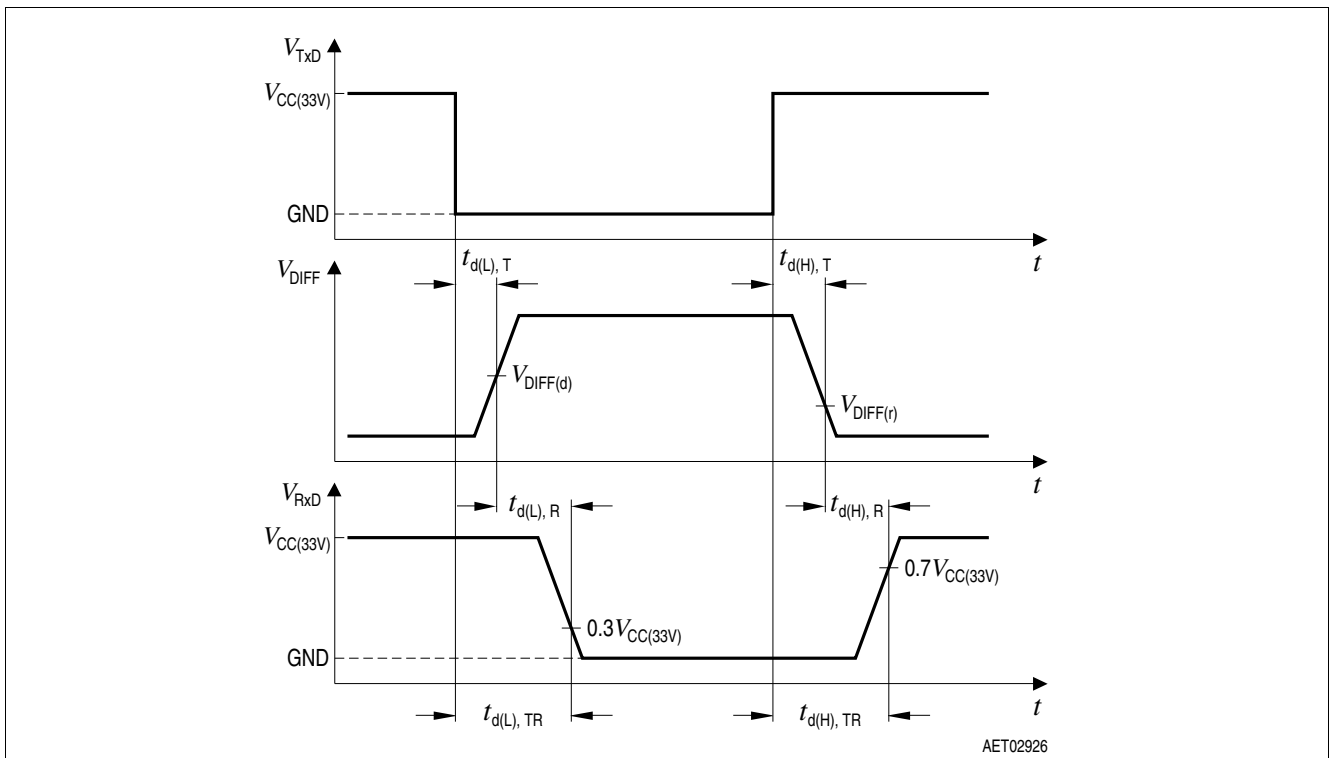

Figure 7 Timing diagram for dynamic characteristics

Diagrams

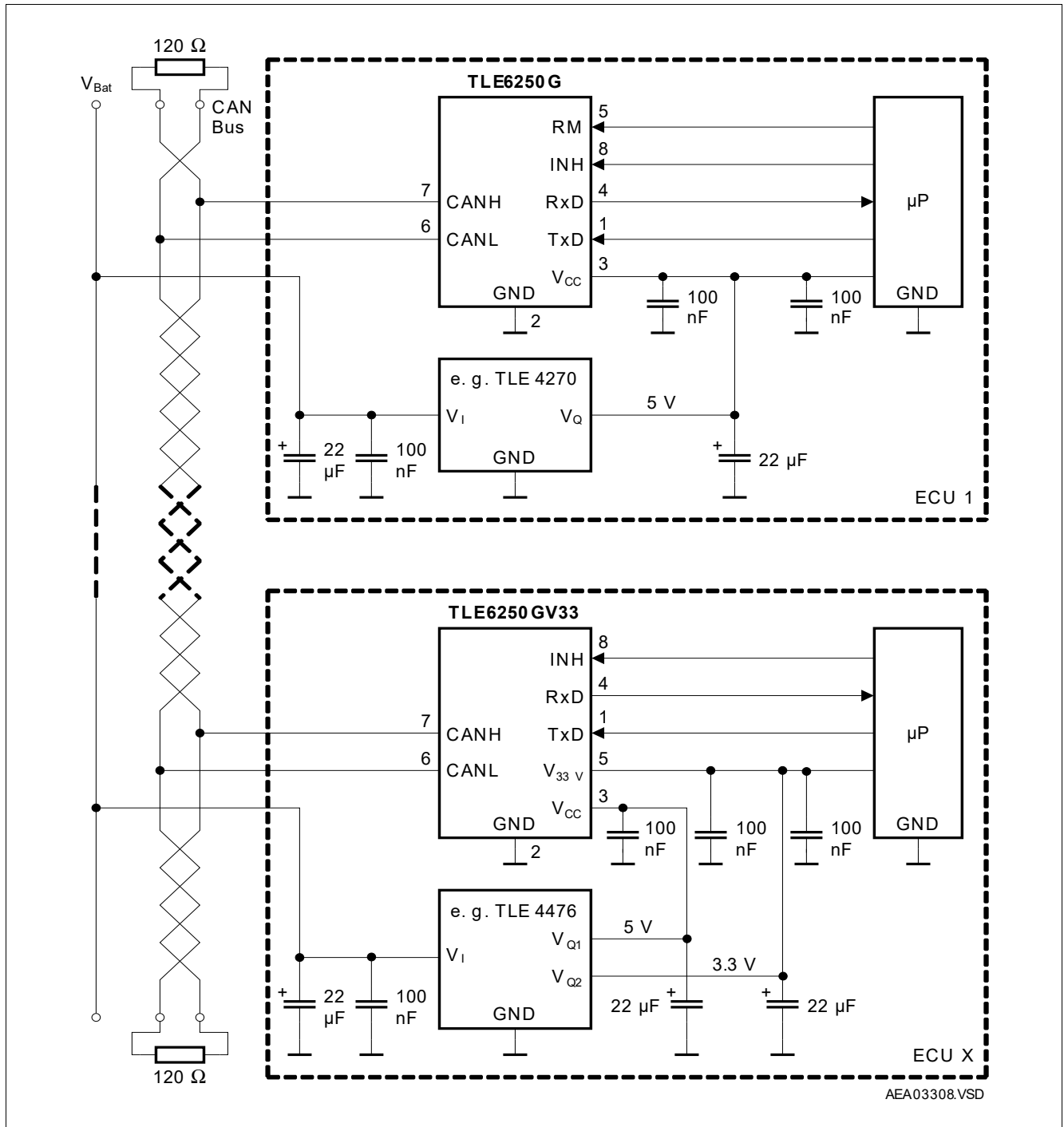

Figure 8 Application circuit TLE6250G with TLE6250GV33

5 Application information

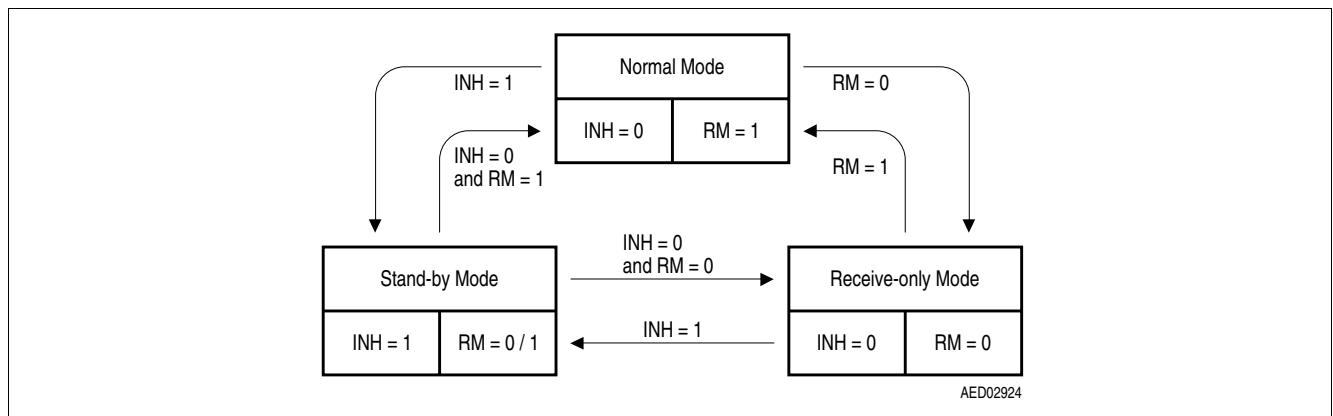

Figure 9 Mode state diagram TLE6250G

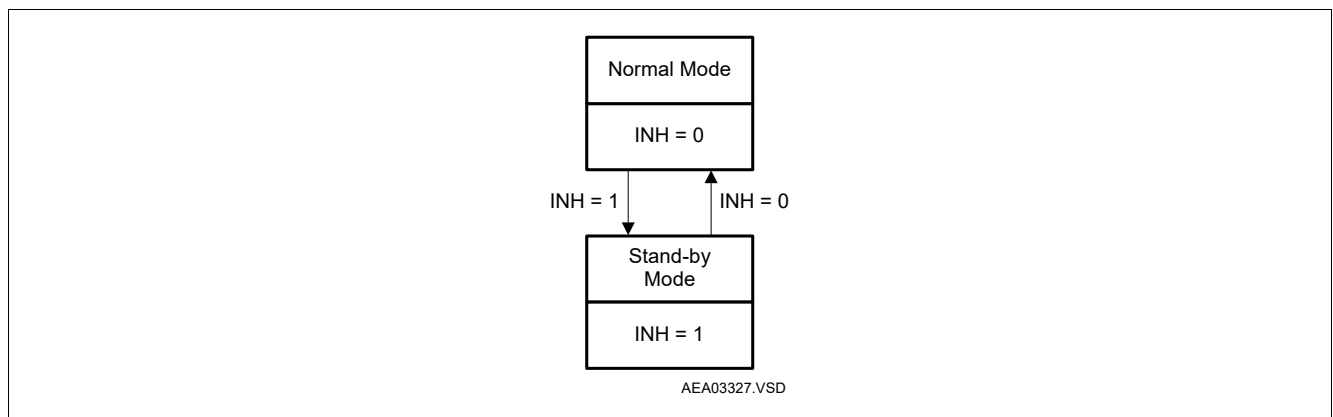

Figure 10 Mode state diagram TLE6250GV33

The TLE6250G offers three modes of operation (see [Figure 9](#)), controlled by the INH and RM pin. The TLE6250GV33 offers two modes of operation (see [Figure 10](#)), controlled by the INH pin respectively.

In normal mode the transceiver can receive and transmit messages. In receive-only mode the transceiver does not transmit signals at the TxD input to the CAN bus. Receive-only mode can be used for diagnostic purposes (to check the bus connections between the nodes) as well as to prevent the bus being blocked by a faulty permanent dominant TxD input signal. Stand-by mode is a low power mode that disables both the receiver and the transmitter.

If the receive-only feature is not used, then the RM pin must be left open. If stand-by mode is not used, then the INH pin must be connected to ground level in order to switch the TLE6250G to normal mode.

Application information for the 3.3 V versions

The TLE6250GV33 can be used for both 3.3 V and 5 V microcontroller logic supply, see [Figure 11](#), [Figure 12](#) and [Figure 13](#). Do not connect external resistors between the power supply and the V_{33V} pin, because that may lead to a voltage drop at this pin.

Application information

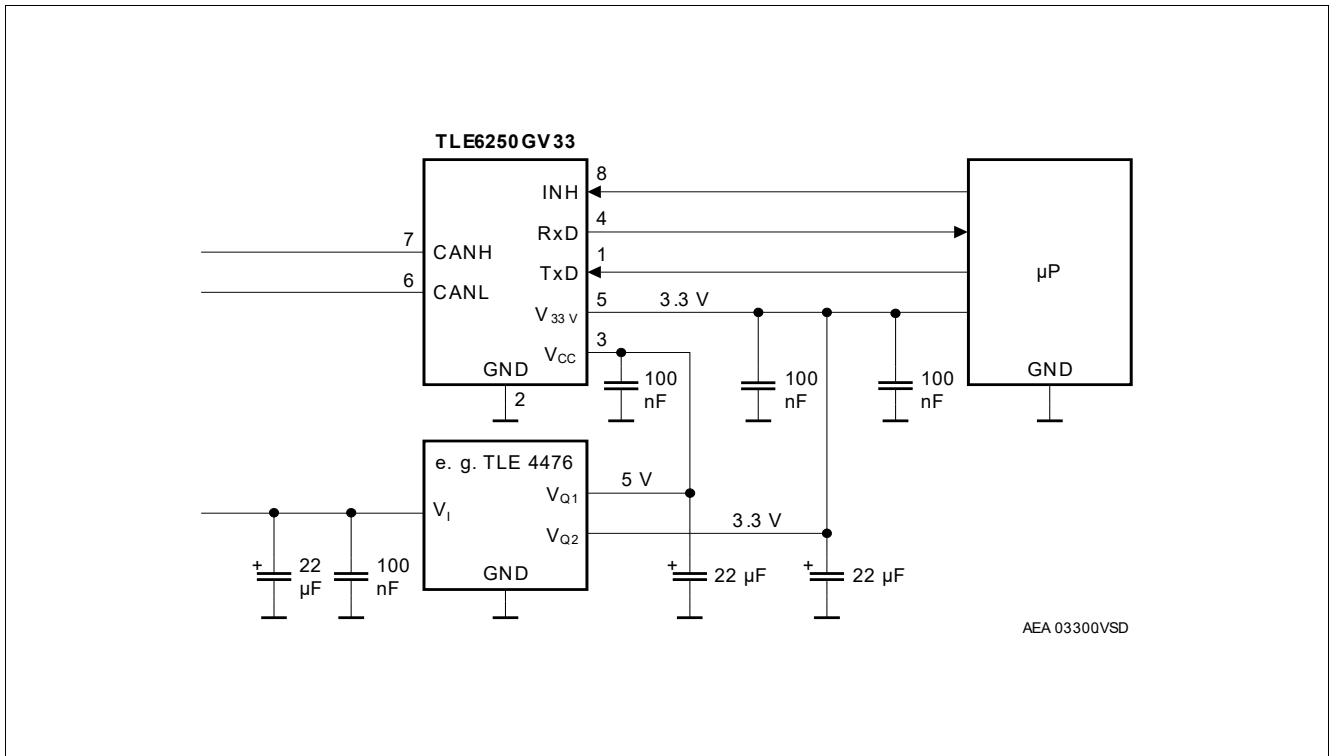

Figure 11 Application circuit TLE6250GV33 used for 3.3 V logic

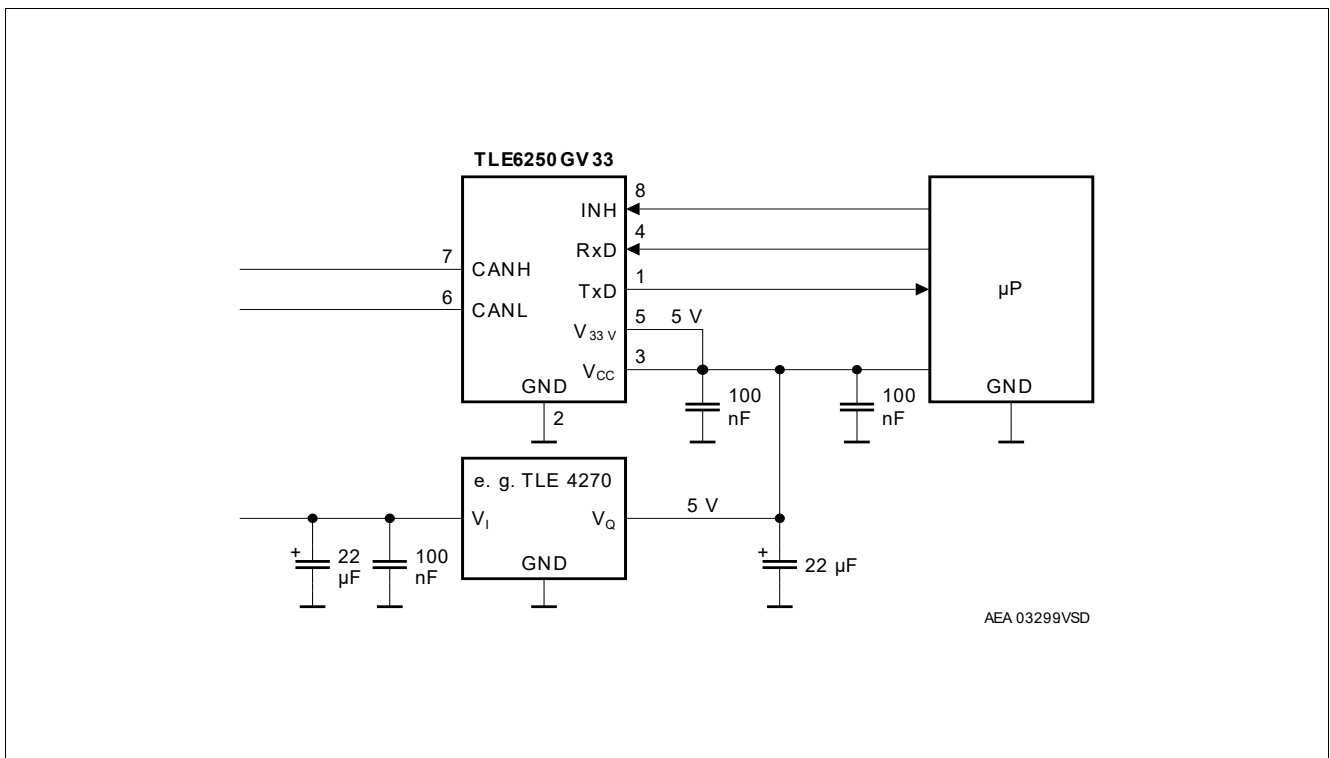

Figure 12 Application circuit TLE6250GV33 used for 5 V logic

Application information

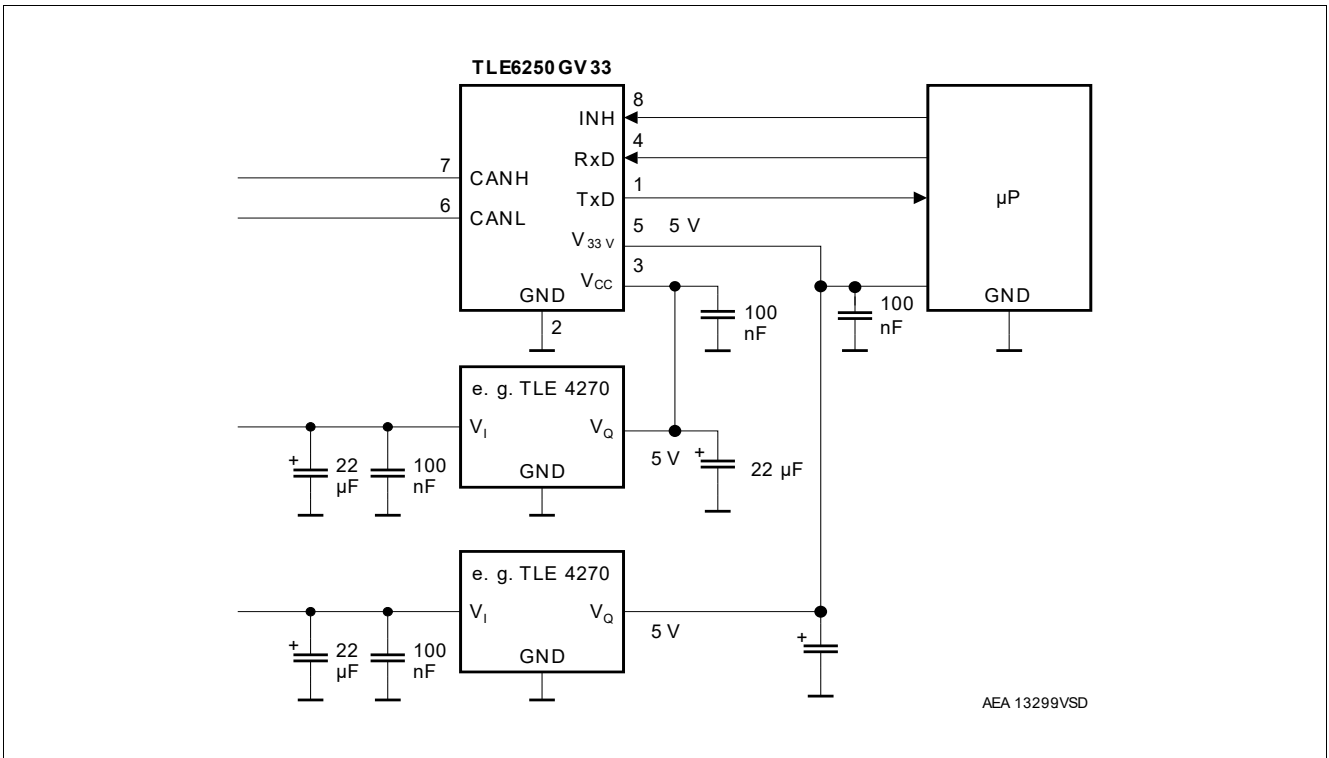

Figure 13 Application circuit TLE6250GV33 used for 5 V logic

6 Package outlines

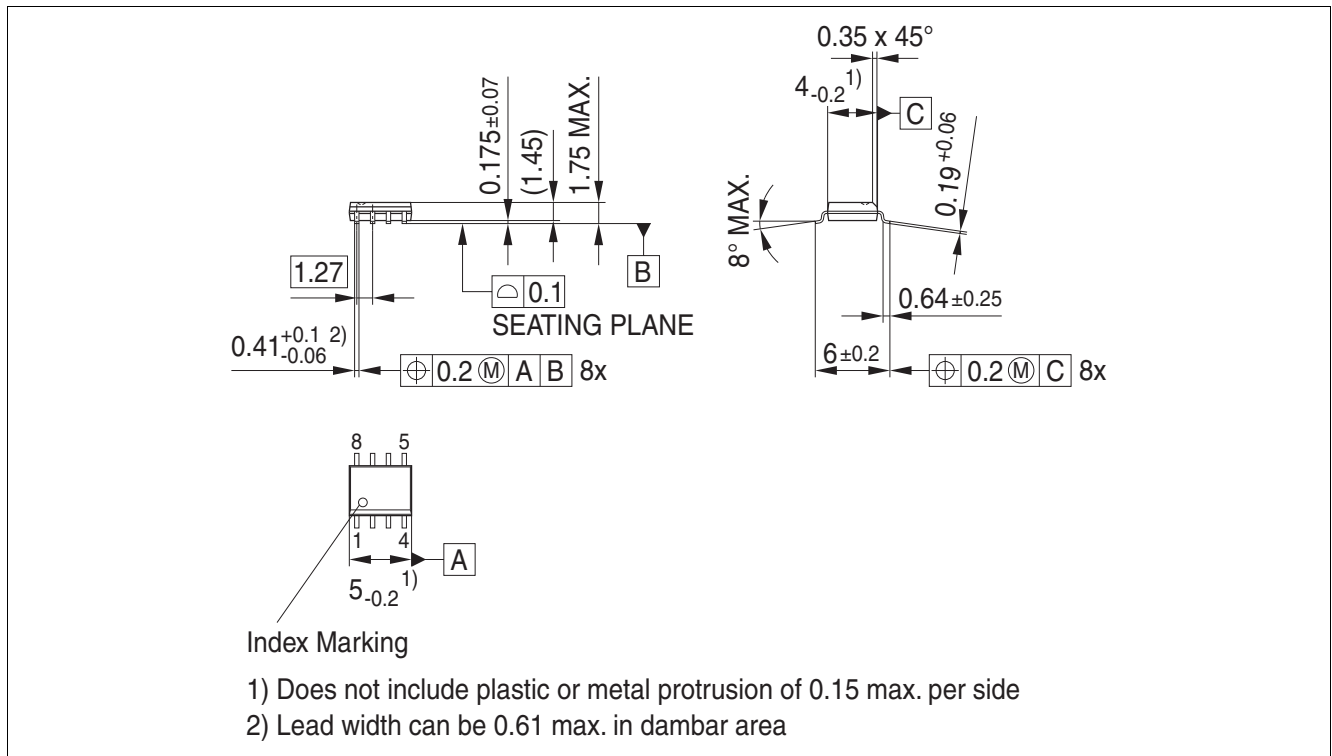

Figure 14 PG-DSO-8 (PG-DSO-8 Plastic Dual Small Outline)¹⁾

Green Product (RoHS compliant)

To meet the world-wide customer requirements for environmentally friendly products and to be compliant with government regulations the device is available as a green product. Green products are RoHS-Compliant (i.e. Pb-free finish on leads and suitable for Pb-free soldering according to IPC/JEDEC J-STD-020).

Further information on packages

<https://www.infineon.com/packages>

1) Dimensions in mm

Revision history

7 Revision history

Revision	Date	Changes
4.11	2019-07-15	Editorial changes
4.1	2017-03-15	<p>New style template</p> <p>Editorial changes</p> <p>Chapter „Overview“:</p> <ul style="list-style-type: none"> • Table of device types and packages: Marking added <p>Chapter „General product characteristics and electrical characteristics“:</p> <ul style="list-style-type: none"> • Table 5: Propagation delay TxD-to-RxD “low” (recessive to dominant) Max. value updated, footnote added • Table 5: Propagation delay TxD-to-RxD “high” (dominant to recessive) Max. value updated, footnote added • Table 8: Propagation delay TxD-to-RxD “low” (recessive to dominant) Max. value updated, footnote added • Table 8: Propagation delay TxD-to-RxD “high” (dominant to recessive) Max. value updated, footnote added
4.0	2008-04-28	<p>Changed symbol for the leakage current CANH/L:</p> <p>From $I_{CANH,IK}$ to $I_{CANH/L,IK}$</p> <p>Max. value for the parameter changed:</p> <p>Output current, $I_{CANH/L,IK}$, $V_{CC} = 0\text{ V}$, $V_{CANH} = V_{CANL} = 7\text{ V}$:</p> <p>From 300 μA to 400 μA</p>

Trademarks

All referenced product or service names and trademarks are the property of their respective owners.

Edition 2019-07-15

Published by

Infineon Technologies AG

81726 Munich, Germany

© 2019 Infineon Technologies AG.

All Rights Reserved.

Do you have a question about any aspect of this document?

Email: erratum@infineon.com

Document reference

Z8F55827012

IMPORTANT NOTICE

The information given in this document shall in no event be regarded as a guarantee of conditions or characteristics ("Beschaffheitsgarantie").

With respect to any examples, hints or any typical values stated herein and/or any information regarding the application of the product, Infineon Technologies hereby disclaims any and all warranties and liabilities of any kind, including without limitation warranties of non-infringement of intellectual property rights of any third party.

In addition, any information given in this document is subject to customer's compliance with its obligations stated in this document and any applicable legal requirements, norms and standards concerning customer's products and any use of the product of Infineon Technologies in customer's applications.

The data contained in this document is exclusively intended for technically trained staff. It is the responsibility of customer's technical departments to evaluate the suitability of the product for the intended application and the completeness of the product information given in this document with respect to such application.

For further information on technology, delivery terms and conditions and prices, please contact the nearest Infineon Technologies Office (www.infineon.com).

WARNINGS

Due to technical requirements products may contain dangerous substances. For information on the types in question please contact your nearest Infineon Technologies office.

Except as otherwise explicitly approved by Infineon Technologies in a written document signed by authorized representatives of Infineon Technologies, Infineon Technologies' products may not be used in any applications where a failure of the product or any consequences of the use thereof can reasonably be expected to result in personal injury.

X-ON Electronics

Largest Supplier of Electrical and Electronic Components

Click to view similar products for [CAN Interface IC](#) category:

Click to view products by [Infineon](#) manufacturer:

Other Similar products are found below :

[416694H](#) [IL41050TA-1E](#) [TJA1042T1J](#) [TJA1042T31J](#) [SN65LBC031DG4](#) [SN65HVD267DR](#) [TJA1050T/CM,118](#) [MAX13051ESA+T](#)
[SJA1000T/N1.118](#) [MCP2561FD-EP](#) [LTM2889IY-5#PBF](#) [IA82527PQF44AR2](#) [ADM3053BRWZ-REEL7](#) [ADM3051CRZ-REEL7](#)
[IA82527PLC44AR2](#) [LT3960JMSE#TRPBF](#) [LT3960JMSE#PBF](#) [TJA1040TCM,118](#) [SIT1050TK](#) [SIT1040TK](#) [MCP25625-ESS](#)
[MAX3053ESA+T](#) [MAX3057ASA+T](#) [MCP2515T-I/ST](#) [NCV7341D21R2G](#) [MC33897CTEFR2](#) [MAX3056ASD+](#) [MAX3054ASD+](#)
[MAX3055ASD+](#) [MAX3051ESA+T](#) [MAX13054ESA+](#) [MAX3051EKA+T](#) [MCP2510-E/SO](#) [MCP2510-I/P](#) [MCP2510-I/SO](#) [MCP2515-I/P](#)
[MCP2515-I/SO](#) [MCP2515-I/ST](#) [MCP2515T-I/SO](#) [MCP2551-E/P](#) [MCP2551-E/SN](#) [MCP2551-I/P](#) [MCP2551-I/SN](#) [MCP2561-E/P](#)
[MCP2561T-ESN](#) [MCP2562FD-E/SN](#) [MCP2562T-ESN](#) [MCP2515-E/ML](#) [PCA82C250T/YM,118](#) [PCA82C251T/YM,118](#)