

TLE8110ED

Smart Multichannel Low Side Switch with Parallel Control and SPI Interface



1 Overview

Features

- Overvoltage, Overtemperature, ESD-Protection
- Direct Parallel PWM Control of all Channels
- safeCOMMUNICATION (SPI and Parallel)
- Efficient Communication Mode: compactCONTROL
- Compatible with 3.3V- and 5V- Micro Controllers I/O ports
- clampSAFE for highly efficient parallel use of the channels
- Green Product
- AEC Qualified

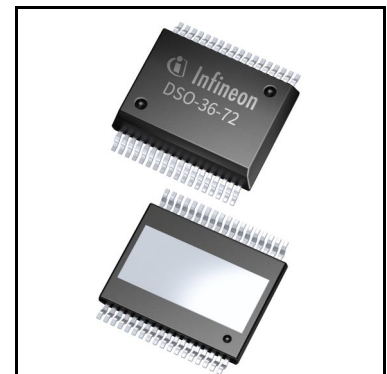

Potential applications

- Power Switch Automotive and Industrial Systems switching Solenoids, Relays and Resistive Loads

Product validation

Qualified for Automotive Applications. Product Validation according to AEC-Q100/101.

Description

10-channel Low-Side Switch in Smart Power Technology [SPT] with **Serial Peripheral Interface [SPI]** and 10 open drain DMOS output stages. The TLE8110ED is protected by embedded protection functions and designed for automotive and industrial applications. The output stages are controlled via Parallel Input Pins for PWM use or SPI Interface. The TLE8110ED is particularly suitable for Engine Management and Powertrain Systems.

Type	Package	Marking
TLE8110ED	PG-DSO-36-72	TLE8110ED

Overview

Table 1 Product Summary

Parameter	Symbol	Value	Unit
Analogue Supply Voltage	V_{DD}	4.50 ... 5.50	V
Digital Supply Voltage	V_{CC}	3.00 ... 5.50	V
Clamping Voltage (CH 1-10)	$V_{DS(CL)typ}$	55	V
On Resistance maximum at $T_j = 25^\circ\text{C}$ and I_{Dnom}	R_{ON1-4}	0.30	Ω
	R_{ON5-6}	0.25	Ω
	R_{ON7-10}	0.60	Ω
On Resistance maximum at $T_j = 150^\circ\text{C}$ and I_{Dnom}	R_{ON1-4}	0.60	Ω
	R_{ON5-6}	0.50	Ω
	R_{ON7-10}	1.20	Ω
Nominal Output current (CH 1-4)	I_{Dnom}	1.50	A
Nominal Output current (CH 5-6)	I_{Dnom}	1.70	A
Nominal Output current (CH 7-10)	I_{Dnom}	0.75	A
Output Current Shut-down Threshold (CH 1-4) min.	$I_{DSD(low)}$	2.60	A
Output Current Shut-down Threshold (CH 5-6) min.	$I_{DSD(low)}$	3.70	A
Output Current Shut-down Threshold (CH 7-10) min.	$I_{DSD(low)}$	1.70	A

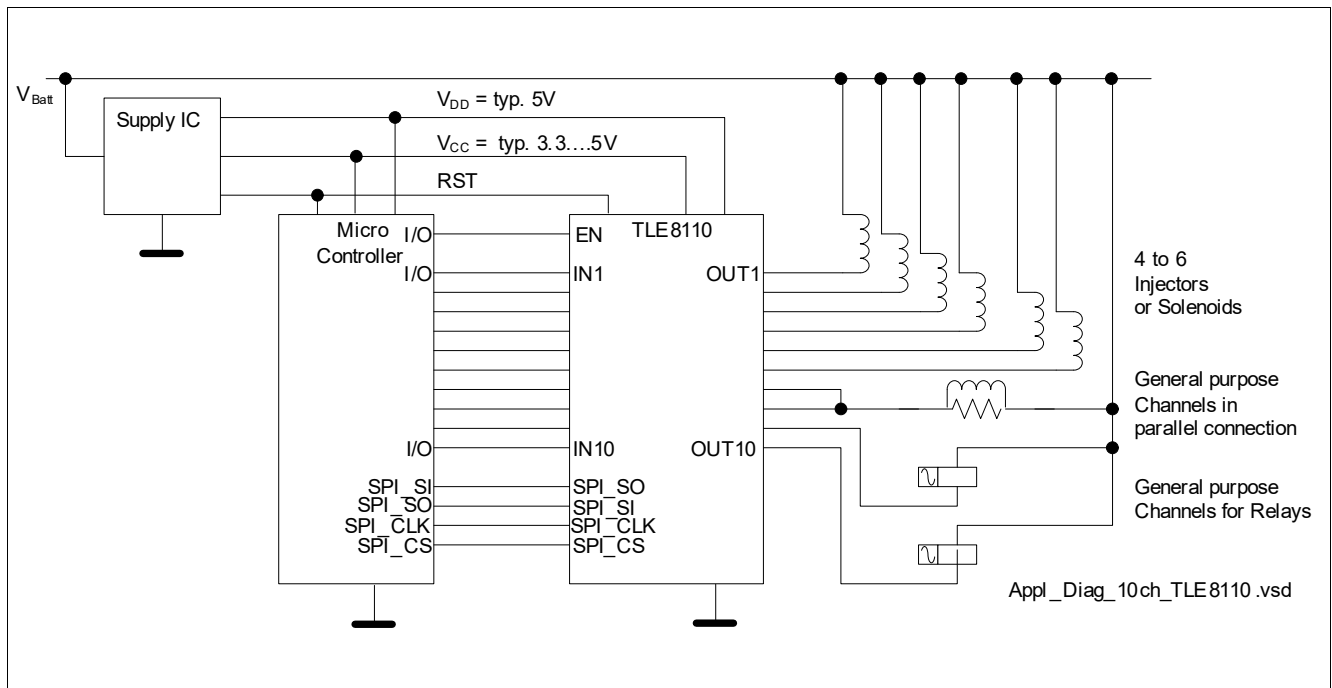

Figure 1 Block Diagram TLE8110ED

Table of Contents

1	Overview	1
2	Block Diagram	5
2.1	Description	5
3	Pin Configuration	7
3.1	Pin Assignment	7
3.2	Pin Definitions and Functions	7
3.3	Terms	9
4	General Product Characteristics	10
4.1	Absolute Maximum Ratings	10
4.2	Functional Range	11
4.3	Thermal Resistance	12
5	Power Supply	13
5.1	Description Power Supply	13
5.2	Electrical Characteristics Power Supply	14
6	Reset and Enable Inputs	16
6.1	Description Reset and Enable Inputs	16
6.2	Electrical Characteristics Reset Inputs	16
7	Power Outputs	18
7.1	Description Power Outputs	18
7.2	Description of the Clamping Structure	19
7.3	Electrical Characteristics Power Outputs	21
7.4	Parallel Connection of the Power Stages	25
8	Diagnosis	28
8.1	Diagnosis Description	28
8.1.1	Open Load diagnosis	28
8.1.2	Overcurrent / Overtemperature diagnosis	29
8.2	Electrical Characteristics Diagnosis	30
9	Parallel Inputs	33
9.1	Description Parallel Inputs	33
9.2	Electrical Characteristics Parallel Inputs	33
10	Protection Functions	34
10.1	Electrical Characteristics Overload Protection Function	35
11	16 bit SPI Interface	39
11.1	Description 16 bit SPI Interface	39
11.2	Timing Diagrams	39
11.3	Electrical Characteristics 16 bit SPI Interface	40
12	Control of the device	42
12.1	Internal Clock	42
12.2	SPI Interface. Signals and Protocol	42
12.2.1	Description 16 bit SPI Interface Signals	42
12.2.2	Daisy Chain	43
12.2.3	SPI Protocol	43

12.2.3.1	16-bit protocol	43
12.2.3.2	2x8-bit protocol	45
12.2.3.3	16- and 2x8-bit protocol mixed	46
12.2.3.4	Daisy-Chain and 2x8-bit protocol	47
12.2.4	safeCOMMUNICATION	48
12.2.4.1	Encoding of the commands	48
12.2.4.2	Modulo-8 Counter	48
12.3	Register and Command - Overview	49
12.3.1	CMD - Commands	52
12.3.1.1	CMD_RSD - Command: Return Short Diagnosis	53
12.3.1.2	CMD_RSDD - Command: Return Short Diagnosis and Device Status	54
12.3.1.3	CMD_RPC - Command: Return Pattern Check	56
12.3.1.4	CMD_RINx - Command: Return Input Pin (INx) - Status	57
12.3.2	DCC - Diagnosis Registers and compactCONTROL	60
12.3.2.1	DRx - Diagnosis Registers Contents	63
12.3.2.2	DRx - Return on DRx Commands	64
12.3.2.3	DMSx/OPSx - Diagnosis Mode Set / Output Pin Set Commands	65
12.3.3	OUTx - Output Control Register CHx	68
12.3.4	ISx - INPUT or Serial Mode Control Register, Bank A and Bank B	69
12.3.5	PMx - Parallel Mode Register CHx	70
12.3.6	DEVS - Device Settings	71
13	Package Outlines	72
14	Revision History	73

Block Diagram

2 Block Diagram

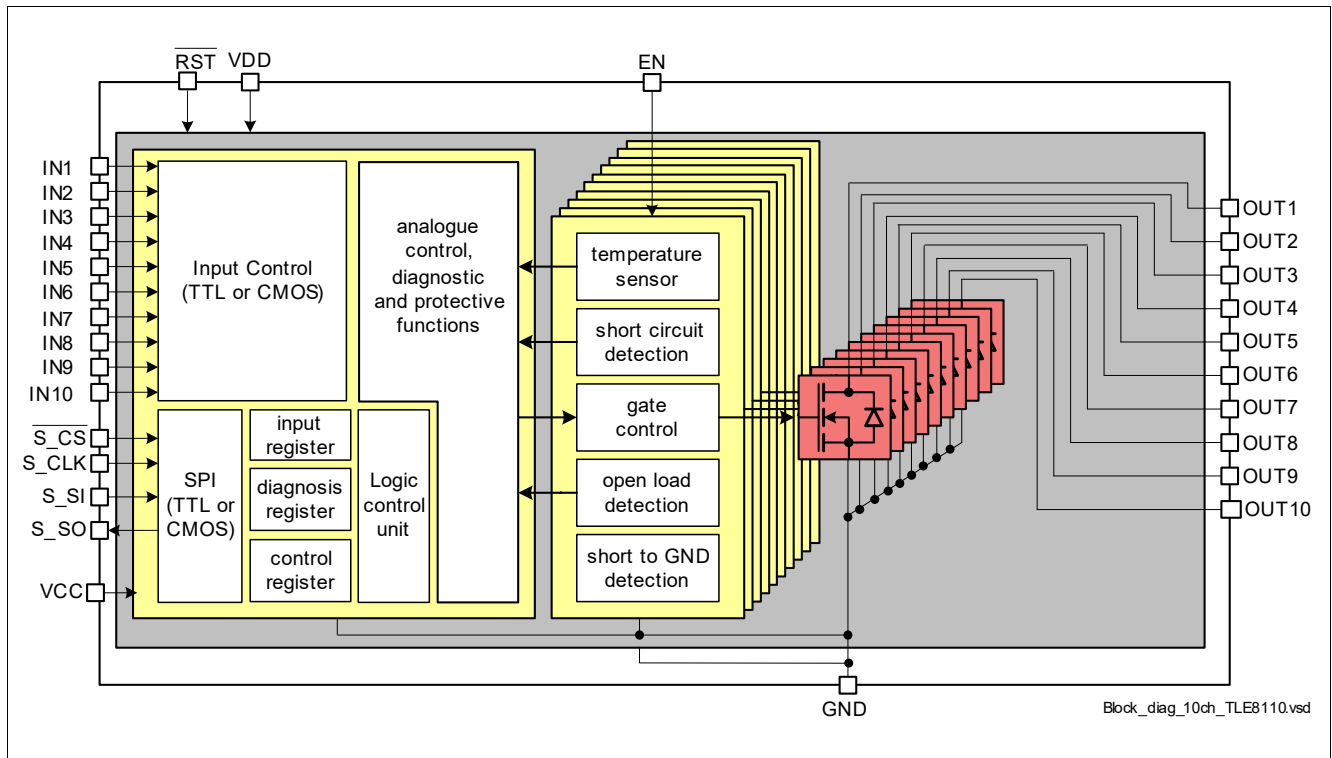

Figure 2 Block Diagram

2.1 Description

Communication

The TLE8110ED is a 10-channel low-side switch in PG-DSO-36-72 package providing embedded protection functions. The 16-bit serial peripheral interface (SPI) can be utilized for control and diagnosis of the device and the loads. The SPI interface provides daisy-chain capability in order to assemble multiple devices in one SPI chain by using the same number of micro-controller pins ¹⁾.

The analogue and the digital part of the device is supplied by 5V. Logic Input and Output Signals are then compatible to 5V logic level [TTL - level]. Optionally, the logic part can be supplied with lower voltages to achieve signal compatibility with e.g. 3.3V logic level [CMOS - level].

The TLE8110ED is equipped with 10 parallel input pins that are routed to each output channel. This allows control of the channels for loads driven by Pulse Width Modulation (PWM). The output channels can also be controlled by SPI.

Reset

The device is equipped with one Reset Pin and one Enable. Reset [RST] serves the whole device, Enable [EN] serves only the Output Control Unit and the Power Stages.

1) Daisy Chain

Block Diagram**Diagnosis**

The device provides diagnosis of the load, including open load, short to GND as well as short circuit to VBatt detection and over-load/ over-temperature indication. The SPI diagnosis flags indicates if latched fault conditions may have occurred.

Protection

Each output stage is protected against short circuit. In case of over load, the affected channel is switched off. The switching off reaction time is dependent on two switching thresholds. Restart of the channel is done by clearing the Diagnosis Register ¹⁾. This feature protects the device against uncontrolled repetitive short circuits.

There is a temperature sensor available for each channel to protect the device in case of over temperature. In case of over temperature the affected channel is switched off and the Over-Temperature Flag is set. Restart of the channel is done by deleting the Flag. This feature protects the device against uncontrolled temperature toggling.

Parallel Connection of Channels

The device is featured with a central clamping structure, so-called CLAMPsafe. This feature ensures a balanced clamping between the channels and allows in case of parallel connection of channels a high efficient usage of the channel capabilities. This parallel mode is additionally featured by best possible parameter- and thermal matching of the channels and by controlling the channels accordingly.

1) Restart after Clear

Pin Configuration

3 Pin Configuration

3.1 Pin Assignment

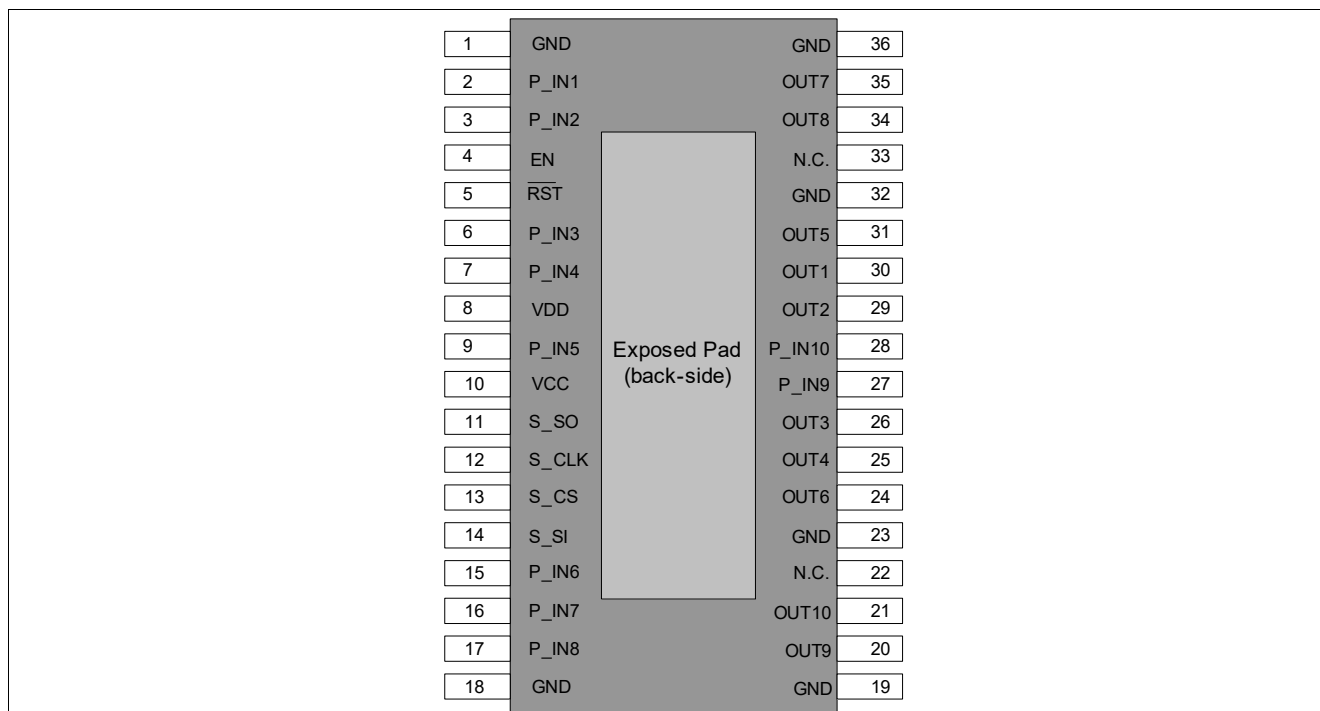

Figure 3 Pin Configuration

3.2 Pin Definitions and Functions

Pin	Symbol	Function
1	GND	Ground
2	P_IN1	Parallel Input Pin 1. Default assignment to Output Channel 1
3	P_IN2	Parallel Input Pin 2. Default assignment to Output Channel 2
4	EN	Enable Input Pin. If not needed, connect with Pull-up resistor to VCC
5	RST	Reset Input Pin (active low). If not needed, connect with Pull-up resistor to VCC
6	P_IN3	Parallel Input Pin 3. Default assignment to Output Channel 3
7	P_IN4	Parallel Input Pin 4. Default assignment to Output Channel 4
8	VDD	Analogue Supply Voltage
9	P_IN5	Parallel Input Pin 5. Default assignment to Output Channel 5
10	VCC	Digital Supply Voltage
11	S_SO	Serial Peripheral Interface [SPI], Serial Output
12	S_CLK	Serial Peripheral Interface [SPI], Clock Input
13	S_CS	Serial Peripheral Interface [SPI], Chip Select (active low)
14	S_SI	Serial Peripheral Interface [SPI], Serial Input
15	P_IN6	Parallel Input Pin 6. Default assignment to Output Channel 6

Pin Configuration

Pin	Symbol	Function
16	P_IN7	Parallel Input Pin 7. Default assignment to Output Channel 7
17	P_IN8	Parallel Input Pin 8. Default assignment to Output Channel 8
18	GND	Ground
19	GND	Ground
20	OUT9	Drain of Power Transistor Channel 9
21	OUT10	Drain of Power Transistor Channel 10
22	N.C.	internally not connected, connect to Ground
23	GND	Ground
24	OUT6	Drain of Power Transistor Channel 6
25	OUT4	Drain of Power Transistor Channel 4
26	OUT3	Drain of Power Transistor Channel 3
27	P_IN9	Parallel Input Pin 9. Default assignment to Output Channel 9
28	P_IN10	Parallel Input Pin 10. Default assignment to Output Channel 10
29	OUT2	Drain of Power Transistor Channel 2
30	OUT1	Drain of Power Transistor Channel 1
31	OUT5	Drain of Power Transistor Channel 5
32	GND	Ground
33	N.C.	internally not connected, connect to Ground
34	OUT8	Drain of Power Transistor Channel 8
35	OUT7	Drain of Power Transistor Channel 7
36	GND	Ground
Exposed Pad		internally not connected, connect to Ground

Note: *The exposed pad of TLE8110ED is not connected to ground pins internally. It is highly recommended to connect the exposed pad to GND pins on the PCB.*

Pin Configuration

3.3 Terms

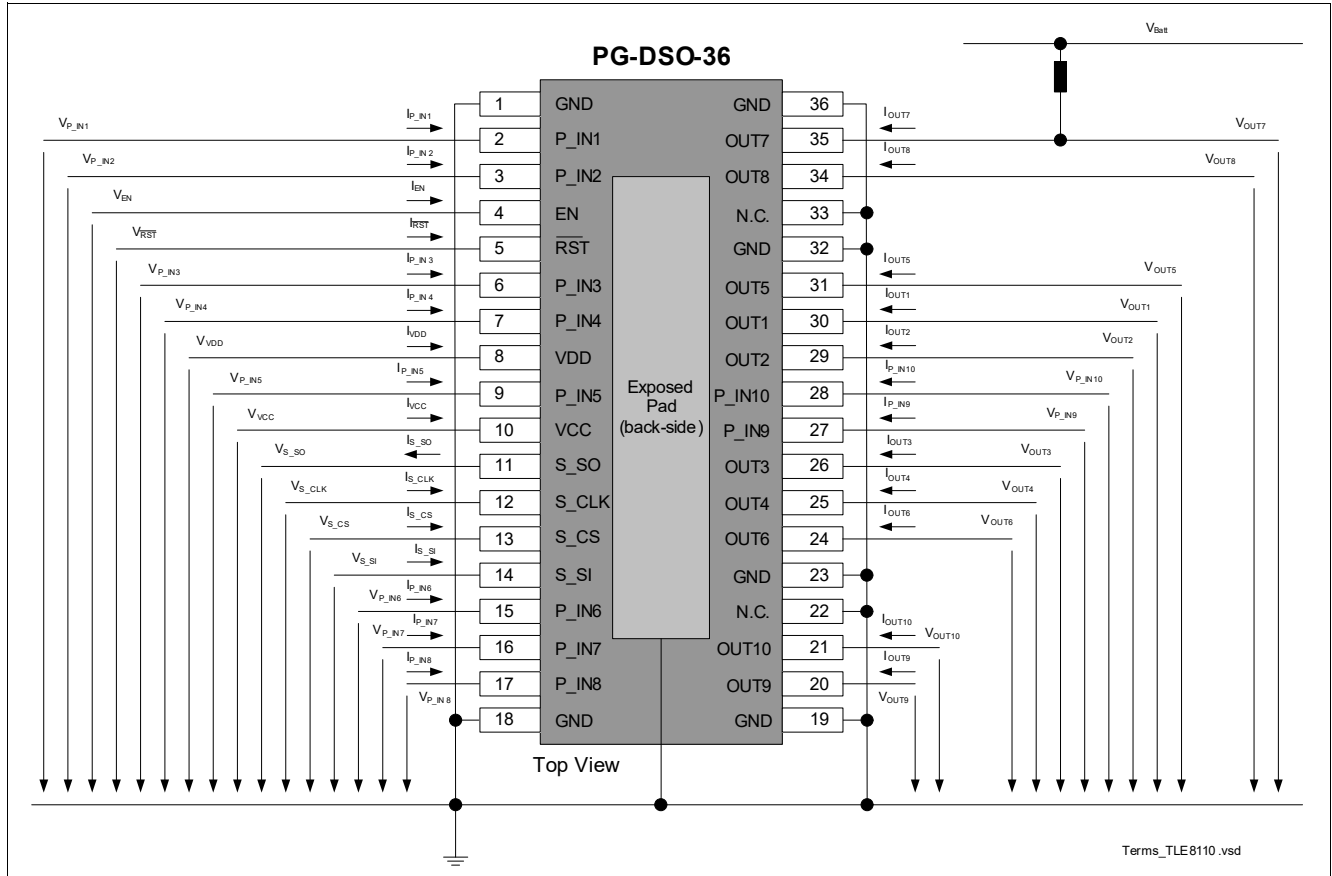

Figure 4 Terms

General Product Characteristics

4 General Product Characteristics

4.1 Absolute Maximum Ratings

Table 2 Absolute Maximum Ratings¹⁾

$T_j = -40^\circ\text{C}$ to $+150^\circ\text{C}$; all voltages with respect to ground, positive current flowing into pin (unless otherwise specified)

Parameter	Symbol	Values			Unit	Note or Test Condition	Number
		Min.	Typ.	Max.			
Supply Voltages							
Digital Supply voltage	V_{CC}	-0.3	-	5.5	V	permanent	P_4.1.1
Digital Supply voltage	V_{CC}	-0.3	-	6.2	V	$t < 10\text{s}$	P_4.1.2
Analogue Supply voltage	V_{DD}	-0.3	-	5.5	V	permanent	P_4.1.3
Analogue Supply voltage	V_{DD}	-0.3	-	6.2	V	$t < 10\text{s}$	P_4.1.4
Power Stages							
Load Current (CH 1 to 10)	I_{Dn}	-	-	$I_{DSD(\text{low})}$	A	-	P_4.1.5
Reverse Current Output (CH 1- 10)	I_{Dn}	$-I_{DSD(\text{low})}$	-	-	A	-	P_4.1.6
Total Ground Current	I_{GND}	-20	-	20	A	-	P_4.1.7
Continuous Drain Source Voltage (Channel 1 to 10)	V_{DSn}	-0.3	-	45	V	-	P_4.1.8
maximum Voltage for short circuit protection on Output	V_{DSn}	-	-	24	V	one event on one single channel	P_4.1.9
Clamping Energy - Single Pulse ^{2) 3)}							
Single Clamping Energy Channel Group 1-4	E_{AS}	-	-	29	mJ	$I_D = 2.6\text{A}$, 1 single pulse	P_4.1.10
Single Clamping Energy Channel Group 5-6	E_{AS}	-	-	31	mJ	$I_D = 3.7\text{A}$, 1 single pulse	P_4.1.11
Single Clamping Energy Channel Group 7-10	E_{AS}	-	-	11	mJ	$I_D = 1.7\text{A}$, 1 single pulse	P_4.1.12
Logic Pins (SPI, INn, EN, RST)							
Input Voltage at all Logic Pin	V_x	-0.3	-	5.5	V	permanent	P_4.1.13
Input Voltage at all Logic Pin	V_x	-0.3	-	6.2	V	$t < 10\text{s}$	P_4.1.14
Input Voltage at Pin 27, 28 (IN9, 10)	V_x	-0.3	-	45	V	permanent	P_4.1.15
Temperatures							
Junction Temperature	T_j	-40	-	150	$^\circ\text{C}$	-	P_4.1.16
Junction Temperature	T_j	-40	-	175	$^\circ\text{C}$	max. 100hrs cumulative	P_4.1.17
Storage Temperature	T_{stg}	-55	-	150	$^\circ\text{C}$	-	P_4.1.18
ESD Robustness							

General Product Characteristics

Table 2 Absolute Maximum Ratings¹⁾ (cont'd)

$T_j = -40^\circ\text{C}$ to $+150^\circ\text{C}$; all voltages with respect to ground, positive current flowing into pin (unless otherwise specified)

Parameter	Symbol	Values			Unit	Note or Test Condition	Number
		Min.	Typ.	Max.			
Electro Static Discharge Voltage "Human Body Model - HBM"	V_{ESD}	-4	-	4	kV	All Pins HBM, ⁴⁾ 1.5KOhm, 100pF	P_4.1.19
Electro Static Discharge Voltage "Charged Device Model - CDM"	V_{ESD}	-500	-	500	V	All Pins CDM ⁵⁾	P_4.1.20
Electro Static Discharge Voltage "Charged Device Model - CDM"	V_{ESD}	-750	-	750	V	Pin 1, 18, 19, 36 (corner pins) CDM ⁵⁾	P_4.1.21

1) Not subject to production test, specified by design.

2) One single channel per time.

3) Triangular Pulse Shape (inductance discharge): $I_D(t) = I_D(0) \cdot (1 - t / t_{\text{pulse}})$; $0 < t < t_{\text{pulse}}$.

4) ESD susceptibility, HBM according to EIA/JESD 22-A114-B.

5) ESD susceptibility, Charged Device Model "CDM" EIA/JESD22-C101-C.

Note: Stresses above the ones listed here may cause permanent damage to the device. Exposure to absolute maximum rating conditions for extended periods may affect device reliability.

1. Integrated protection functions are designed to prevent IC destruction under fault conditions described in the data sheet. Fault conditions are considered as "outside" normal operating range. Protection functions are not designed for continuous repetitive operation.

4.2 Functional Range

Table 3 Functional Range

Parameter	Symbol	Values			Unit	Note or Test Condition	Number
		Min.	Typ.	Max.			
Supply Voltages							
Analogue Supply Voltage	V_{DD}	4.5	-	5.5	V	-	P_4.2.1
Digital Supply Voltage	V_{CC}	3	-	V_{DD}	V	-	P_4.2.2
Digital Supply Voltage	V_{CC}	V_{DD}	-	5.5	V	leakage Currents (ICC) might increase if $V_{\text{CC}} > V_{\text{DD}}$	P_4.2.3
Power Stages							
Ground Current	$I_{\text{GND_typ}}$		9		A	resistive loads ¹⁾	P_4.2.4
Temperatures							
Junction Temperature	T_j	-40	-	150	$^\circ\text{C}$	-	P_4.2.5
Junction Temperature	T_j	-40	-	175	$^\circ\text{C}$	for 100hrs ¹⁾	P_4.2.6

1) Not subject to production test, specified by design

General Product Characteristics

Note: Within the functional range the IC operates as described in the circuit description. The electrical characteristics are specified within the conditions given in the related electrical characteristics table.

4.3 Thermal Resistance

Table 4 Thermal Resistance

Parameter	Symbol	Values			Unit	Note or Test Condition	Number
		Min.	Typ.	Max.			
Junction to Soldering Point	R_{thJC}		1	1.50	K/W	$P_{vtot} = 3W$ ^{1) 2)}	P_4.3.1
Junction to ambient	R_{thJA}		21.5	22	K/W	³⁾	P_4.3.2

1) Not subject to production test, specified by design.

2) Homogenous power distribution over all channels (all power stages equally heated), dependent on cooling set-up.

3) Specified R_{thJA} value is according to JEDEC JESD51 -5, -7 at natural convection on FR4 2s2p board; the product (chip and package) was simulated on a 76.2 x 114.3 x 1.5 mm board with 2 inner copper layers (2 x 70 μm , 2 x 35 μm CU).

5 Power Supply

5.1 Description Power Supply

The TLE8110ED is supplied by analogue power supply line V_{DD} which is used for the analogue functions of the device, such as the gate control of the power stages. The digital power supply line V_{CC} is used to supply the digital part and offers the possibility to adapt the logic level of the serial output pins to lower logic levels.

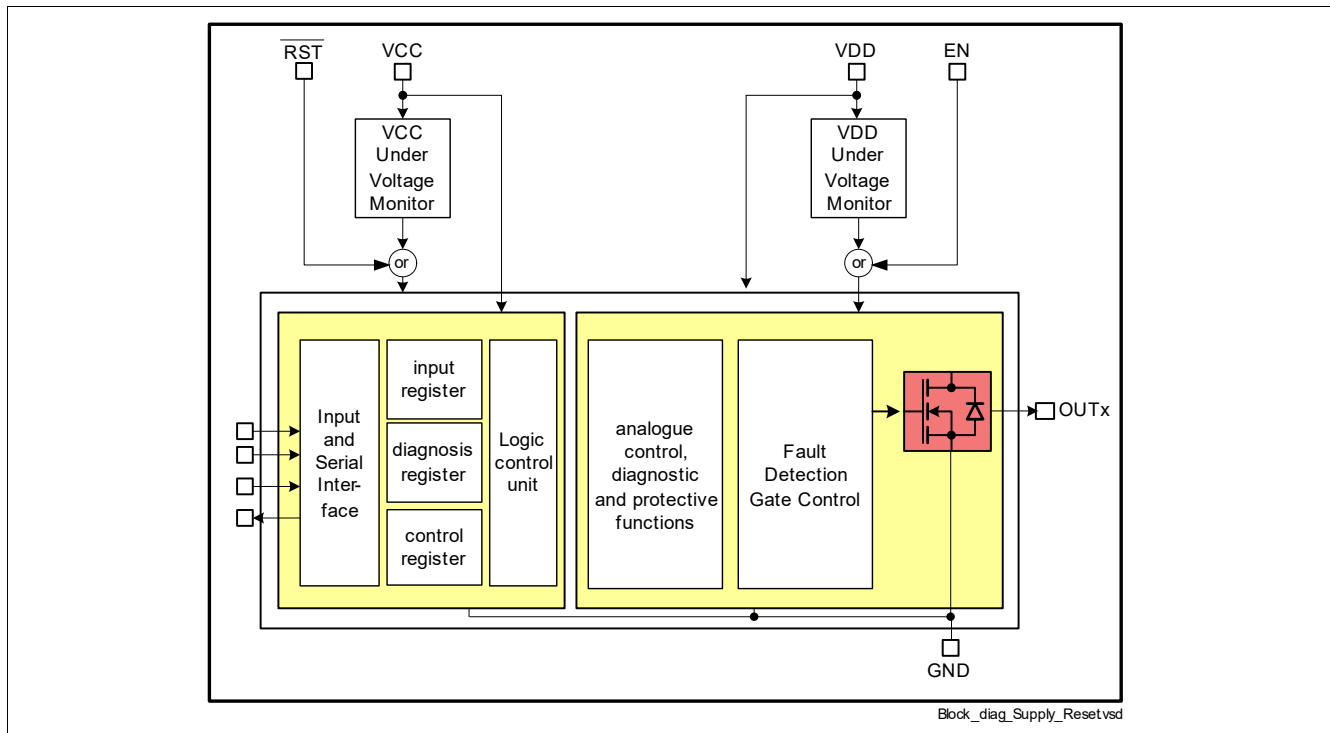

Figure 5 Block Diagram Supply and Reset

Description Supply

The Supply Voltage Pins are monitored during the power-on phase and under normal operating conditions for under voltage.

If during Power-on the increasing supply voltage exceeds the Supply Power-on Switching Threshold, the internal Reset is released after an internal delay has expired.

In case of under voltage, a device internal reset is performed. The Switching Threshold for this case is the Power-on Switching threshold minus the Switching Hysteresis.

In case of under voltage on the analogue supply line V_{DD} the outputs are turned off but the content of the registers and the functionality of the logic part is kept alive. In case of under voltage on the digital supply V_{CC} line, a complete reset including the registers is performed.

After returning back to normal supply voltage and an internal delay, the related functional blocks are turned on again. For more details, refer to the chapter "Reset".

The device internal under-voltage set will set the related bits in SDS (Short Diagnosis and Device Status) to allow the micro controller to detect this reset. For more information, refer to the chapter "Control of the Device".

Power Supply

5.2 Electrical Characteristics Power Supply

Table 5 Electrical Characteristics: Power Supply

3.0V < V_{CC} < 5.5V; 4.5V < V_{DD} < 5.5V, T_j = -40°C to +150°C, all voltages with respect to ground, positive current flowing into pin (unless otherwise specified)

Parameter	Symbol	Values			Unit	Note or Test Condition	Number
		Min.	Typ.	Max.			
Digital Supply and Power-on Reset							
Digital Supply Voltage	V _{CC}	3	–	5.5	V	–	P_5.2.1
Digital Supply Current during Reset (V _{CC} < V _{CCpo})	I _{CCstb}	–	15	20	μA	f _{SCLK} = 0Hz, S_CS = V _{CC} , T _j = 85°C, V _{CC} = 2.0 V, V _{DD} > V _{CC} , 1)	P_5.2.2 a)
		–	20	40	μA	f _{SCLK} = 0Hz, S_CS = V _{CC} , T _j = 150°C, V _{CC} = 2.0V, V _{DD} > V _{CC}	b)
Digital Supply Current during Reset (VRST > VRSTI)	I _{CCstb}	–	2	5	μA	f _{SCLK} = 0Hz, S_CS = V _{CC} , T _j = 85°C, V _{DD} > V _{CC} , 1)	P_5.2.3 a)
		–	5	15	μA	f _{SCLK} = 0Hz, S_CS = V _{CC} , T _j = 150°C, V _{DD} > V _{CC}	b)
Digital Supply Operating Current V _{CC} = 3.3V	I _{CC}	–	0.15	2	mA	f _{SCLK} = 0Hz, T _j = 150°C, all Channels ON, 1)	P_5.2.4 a)
		–	0.5	5	mA	f _{SCLK} = 5MHz, T _j = 150°C, all Channels ON, 1) 2)	b)
Digital Supply Operating Current V _{CC} = 5.5V	I _{CC}	–	0.25	2	mA	f _{SCLK} = 0Hz, T _j = 150°C, all Channels ON	P_5.2.5 a)
		–	0.8	10	mA	f _{SCLK} = 5MHz, T _j = 150°C, all Channels ON, 1) 2)	b)
Digital Supply Power-on Switching Threshold	V _{CCpo}	1.9	2.8	3	V	V _{CC} increasing	P_5.2.6

Power Supply

Table 5 Electrical Characteristics: Power Supply

$3.0V < V_{CC} < 5.5V$; $4.5V < V_{DD} < 5.5V$, $T_j = -40^\circ\text{C}$ to $+150^\circ\text{C}$, all voltages with respect to ground, positive current flowing into pin (unless otherwise specified)

Parameter	Symbol	Values			Unit	Note or Test Condition	Number
		Min.	Typ.	Max.			
Digital Supply Switching Hysteresis	V_{CChy}	100	300	500	mV	¹⁾	P_5.2.7

Analogue Supply and Power-on Reset

Analogue Supply Voltage	V_{DD}	4.5	–	5.5	V	–	P_5.2.8
Analogue Supply Current during Reset ($V_{DD} < V_{DDpo}$)	I_{DDstb}	–	10	20	μA	$f_{SCLK} = 0\text{Hz}$, $T_j = 85^\circ\text{C}$, $V_{DD} = 2\text{V}$, ¹⁾	P_5.2.9 a)
		–	15	40	μA	$f_{SCLK} = 0\text{Hz}$, $T_j = 150^\circ\text{C}$, $V_{DD} = 2\text{V}$	b)
Analogue Supply Current during Reset ($V_{EN} < V_{ENI}$)	I_{DDstb}	–	1	5	μA	$f_{SCLK} = 0\text{Hz}$, $T_j = 85^\circ\text{C}$, ¹⁾	P_5.2.10 a)
		–	2	15	μA	$f_{SCLK} = 0\text{Hz}$, $T_j = 150^\circ\text{C}$	b)
Analogue Supply Operating Current	I_{DD}	–	8	25	mA	$f_{SCLK} = 0\dots 5\text{MHz}$, $T_j = 150^\circ\text{C}$, all Channels ON, ¹⁾	P_5.2.11
Analogue Supply Power-on Switching Threshold	V_{DDpo}	3	4.2	4.5	V	V_{DD} increasing	P_5.2.12
Analogue Supply Switching Hysteresis	V_{DDhy}	100	200	400	mV	¹⁾	P_5.2.13
Analogue Supply Power-on Delay Time	t_{VDDpo}	–	100	200	μs	V_{DD} increasing, ¹⁾	P_5.2.14

1) Parameter not subject to production test. Specified by design.

2) C = 50pF connected to S_SO.

Reset and Enable Inputs

6 Reset and Enable Inputs

6.1 Description Reset and Enable Inputs

The TLE8110ED contains one Reset- and one Enable Input Pin as can be seen in [Figure 5](#).

Description:

Reset Pin [$\overline{\text{RST}}$] is the main reset and acts as the internal under voltage reset monitoring of the digital supply voltage V_{CC} : As soon as $\overline{\text{RST}}$ is pulled low, the whole device including the control registers is reset.

The Enable Pin [EN] resets only the Output channels and the control circuits. The content of the all registers is kept. This functions offers the possibility of a “soft” reset turning off only the Output lines but keeping alive the SPI communication and the contents of the control registers. This allows the read out of the diagnosis and setting up the device during or directly after Reset.

6.2 Electrical Characteristics Reset Inputs

Table 6 Electrical Characteristics: Reset Inputs

$3.0V < V_{CC} < 5.5V$; $4.5V < V_{DD} < 5.5V$, $T_j = -40^\circ\text{C}$ to $+150^\circ\text{C}$, all voltages with respect to ground, positive current flowing into pin (unless otherwise specified)

Parameter	Symbol	Values			Unit	Note or Test Condition	Number
		Min.	Typ.	Max.			
Reset Input Pin [$\overline{\text{RST}}$]							
Low Level of $\overline{\text{RST}}$	V_{RSTl}	-0.3	-	$V_{CC} * 0.2$	V	-	P_6.2.1
High Level of $\overline{\text{RST}}$	V_{RSTh}	$V_{CC} * 0.4$	-	V_{CC}	V	-	P_6.2.2
$\overline{\text{RST}}$ Switching Hysteresis	V_{RSThy}	20	100	300	mV	¹⁾	P_6.2.3
Reset Pin pull-down Current	I_{RSTresh}	20	40	85	μA	$V_{\overline{\text{RST}}} = 5V$	P_6.2.4
	I_{RSTresl}	2.4	-	-	μA	$V_{\overline{\text{RST}}} = 0.6V$, ¹⁾	
Required Reset Duration time $\overline{\text{RST}}$	t_{RSTmin}	2	-	-	μs	¹⁾	P_6.2.5
Enable Input Pin [EN]							
Low Level of EN	V_{ENl}	-0.3	-	$V * 0.2$	$V_{CC} * 0.2$	-	P_6.2.6
High Level of EN	V_{ENh}	$V_{CC} * 0.4$	-	V_{CC}	V	-	P_6.2.7
EN Switching Hysteresis	V_{ENhy}	20	60	300	mV	¹⁾	P_6.2.8
Enable Pin pull-down Current	I_{ENresh}	5	35	85	μA	$V_{\overline{\text{EN}}} = 5V$	P_6.2.9
	I_{ENresl}	2.4	-	-	μA	$V_{\overline{\text{EN}}} = 0.6V$, ¹⁾	
Enable Reaction Time (reaction of OUTx)	t_{ENrr}	-	4	-	μs	¹⁾	P_6.2.10
Required Enable Duration time EN	t_{ENmin}	2	-	-	μs	¹⁾	P_6.2.11

¹⁾ Parameter not subject to production test. Specified by design.

Reset and Enable Inputs

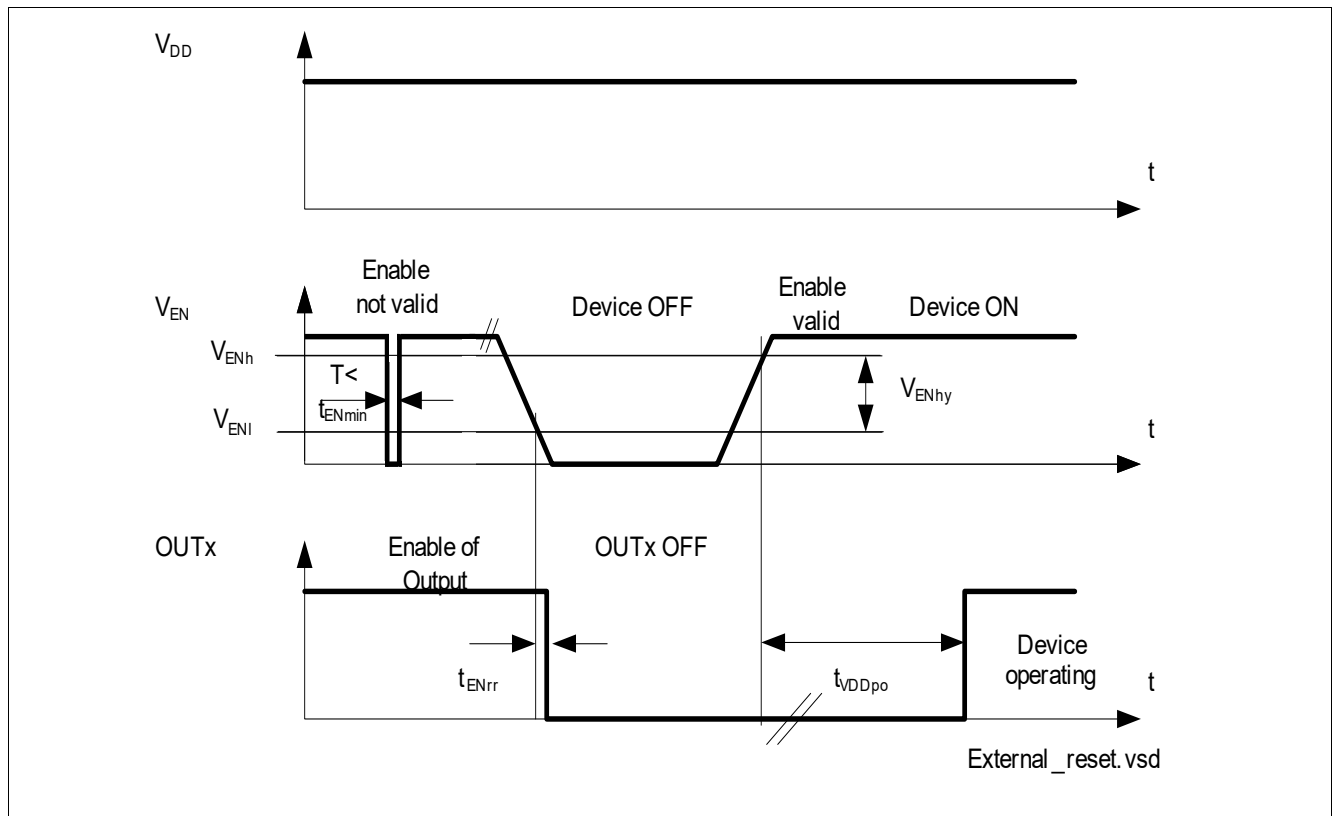

Figure 6 Timing

Power Outputs

7 Power Outputs

7.1 Description Power Outputs

The TLE8110ED is a 10 channel low-side powertrain switch. The power stages are built by N-channel power MOSFET transistors. The device is a universal multichannel switch but mostly suited for the use in Engine Management Systems [EMS]. Within an EMS, the best fit of the channels to the typical loads is:

- Channel 1 to 4 for Injector valves or mid-sized solenoids with a nominal current requirement of 1.5A,
- Channel 5 to 6 for mid-sized solenoids or Injector valves with nominal current requirement of 1.7A,
- Channel 7 to 10 for small solenoids or relays with a nominal current requirement of 0.75A.

Channel 1 to 10 provide enhanced clamping capabilities of typically 55V best suited for inductive loads such as injectors and valves. It is recommended in case of an inductive load, to connect an external free wheeling- or clamping diode, where-ever possible to reduce power dissipation.

All channels can be connected in parallel. Channels 1 to 4, 5 to 6 and 7 to 10 are prepared by matching for parallel connection with the possibility to use a high portion of the capability of each single channel also in parallel mode (refer to [Chapter 7.4](#)).

Channel 5 and 6 have a higher current shut down threshold to allow to connect in parallel mode a load with high inrush-current, such as a lambda sensor heater.

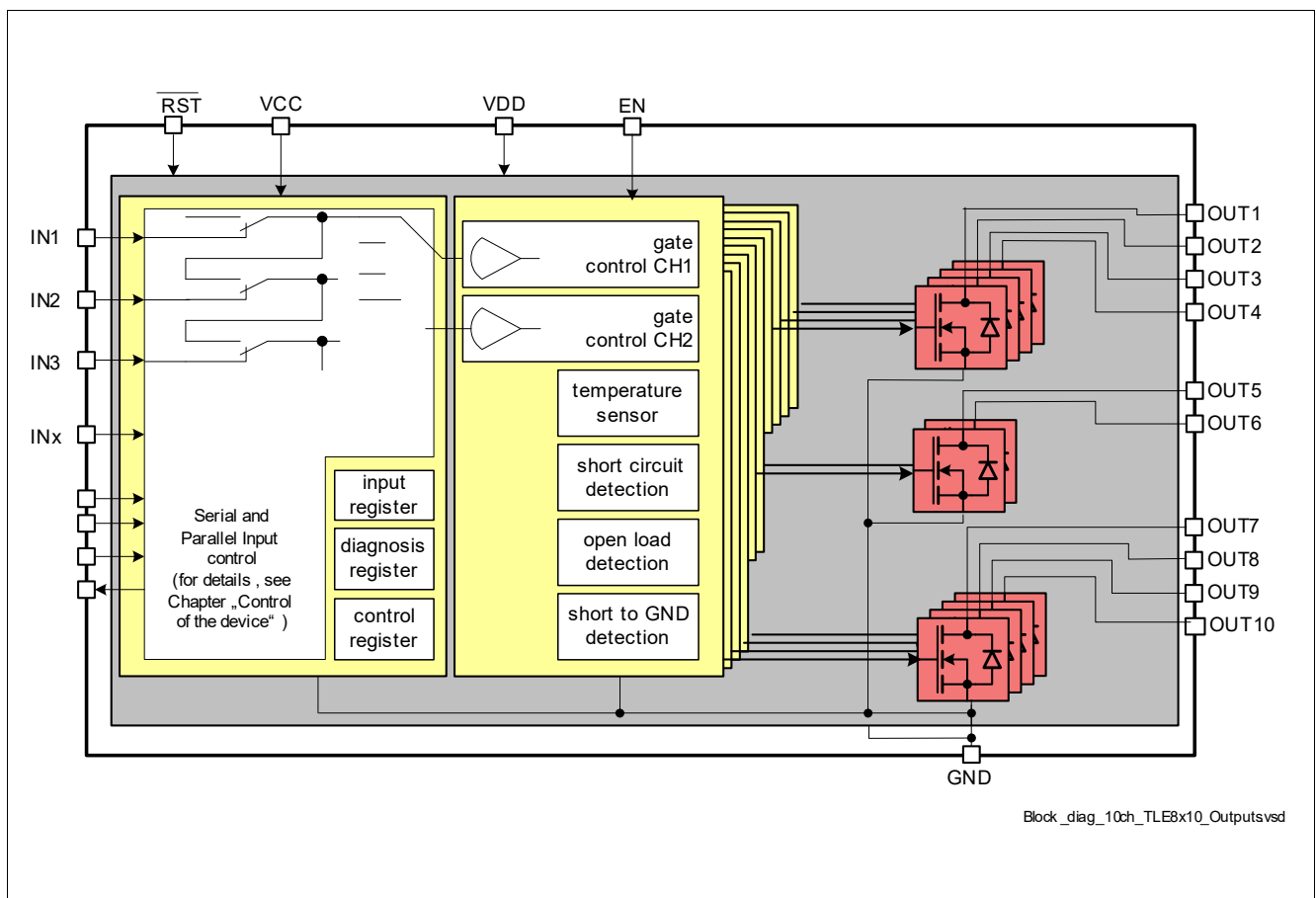

Figure 7 Block Diagram of Control and Power Outputs

Power Outputs

7.2 Description of the Clamping Structure

When switching off inductive loads, the potential at pin OUT rises to $V_{DS(CL)}$ potential, because the inductance intends to continue driving the current. The clamping voltage is necessary to prevent destruction of the device, see [Figure 8](#) for the clamping circuit principle. Nevertheless, the maximum allowed load inductance is limited.

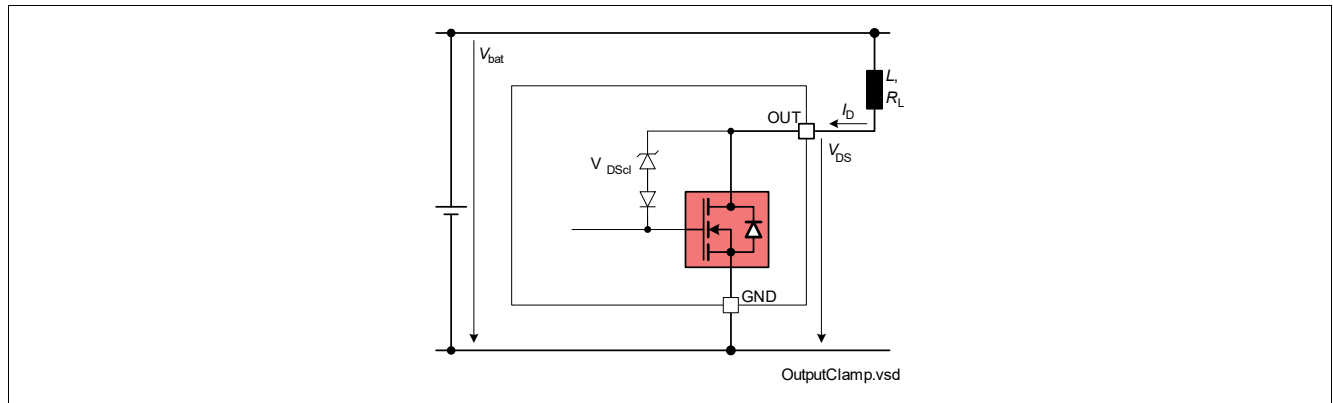

Figure 8 Internal Clamping Principle

Clamping Energy

During demagnetization of inductive loads, energy has to be dissipated in the device. This energy can be calculated with following equation:

$$E = V_{DS(CL)} \cdot \frac{L_L}{R_L} \cdot \left[I_L - \frac{V_{DS(CL)} - V_{BAT}}{R_L} \cdot \ln \left(1 + \frac{R_L \cdot I_L}{V_{DS(CL)} - V_{BAT}} \right) \right] \quad (7.1)$$

The maximum energy, which is converted into heat, is limited by the thermal design of the component.

Attention: *It is strongly recommended to measure the load Energy and Current under operating conditions, example of measurement setup is shown in [Figure 9](#). Load small-signal parameters might not reflect the real load behavior under operating conditions, see [Figure 10](#). For more details please refer to the Application Note “Switching Inductive Loads”.*

Power Outputs

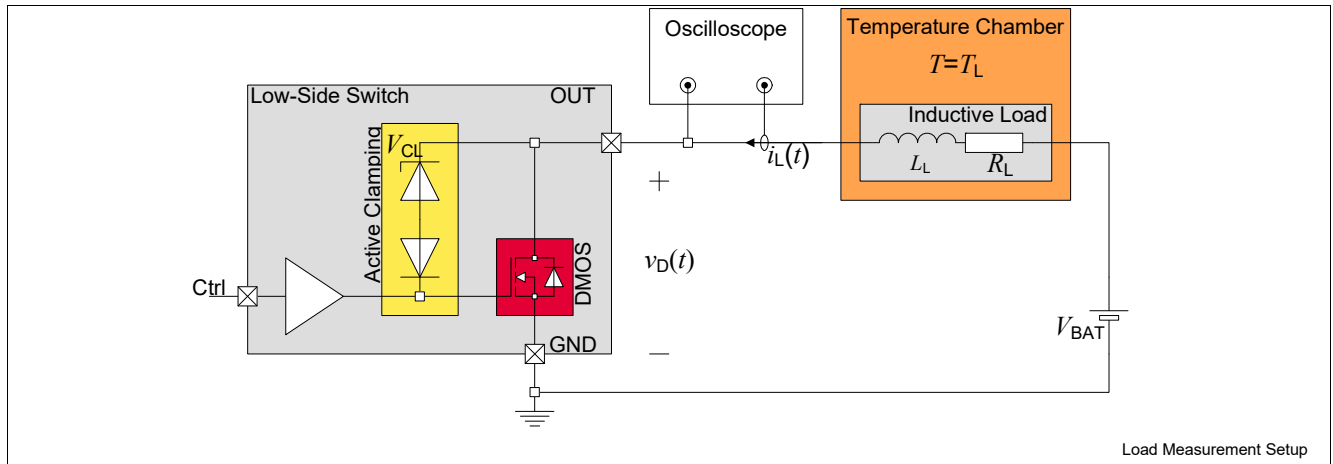

Figure 9 E_{CL} measurement setup

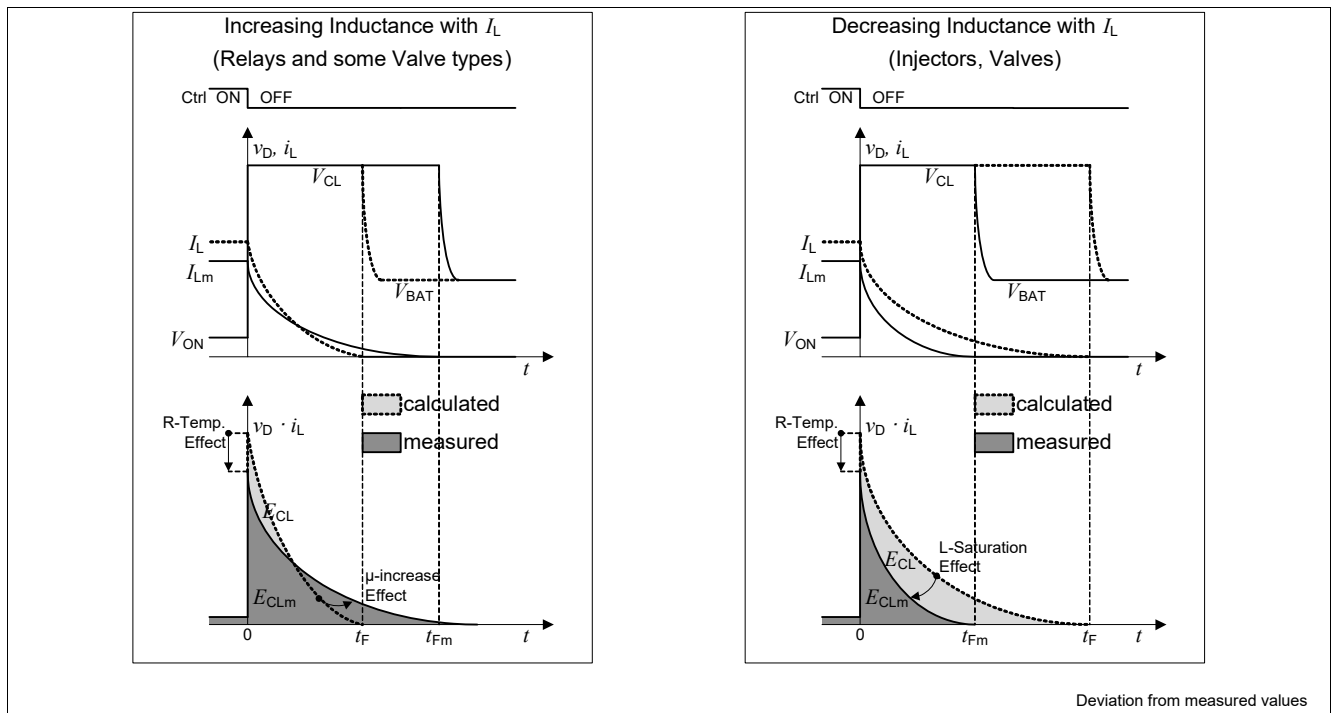

Figure 10 Deviation of calculation from measurement

Power Outputs

7.3 Electrical Characteristics Power Outputs

Table 7 Electrical Characteristics: Power Outputs

3.0V < V_{CC} < 5.5V; 4.5V < V_{DD} < 5.5V, T_j = -40°C to +150°C, all voltages with respect to ground, positive current flowing into pin (unless otherwise specified)

Parameter	Symbol	Values			Unit	Note or Test Condition	Number
		Min.	Typ.	Max.			
Output Channel Resistance							
On State Resistance Channel Group 1-4	R _{DSon}	-	0.3	-	Ohm	I _{Dnom} = 1.5A, T _j = 25°C ¹⁾	P_7.3.1
		-	0.45	0.6	Ohm	I _{Dnom} = 1.5A, T _j = 150°C	
On State Resistance Channel Group 5-6	R _{DSon}	-	0.25	-	Ohm	I _{Dnom} = 1.7A, T _j = 25°C ¹⁾	P_7.3.2
		-	0.35	0.5	Ohm	I _{Dnom} = 1.7A, T _j = 150°C	
On State Resistance Channel Group 7-10	R _{DSon}	-	0.6	-	Ohm	I _{Dnom} = 0.75A, T _j = 25°C ¹⁾	P_7.3.3
		-	0.85	1.2	Ohm	I _{Dnom} = 0.75A, T _j = 150°C	
Clamping Energy - Repetitive¹⁾²⁾³⁾⁴⁾							
Channel Group 1-4							
Repetitive Clamping Energy	E _{AR}	-	-	11	mJ	I _D = 1.0A, 10 ⁹ cycles	P_7.3.4
		-	-	12	mJ	I _D = 2.1A, 10 ⁴ cycles	
		-	-	15	mJ	I _D = 2.6A, 10 cycles ⁵⁾	
Channel 5-6							
Repetitive Clamping Energy	E _{AR}	-	-	13	mJ	I _D = 1.3A, 10 ⁹ cycles	P_7.3.5
		-	-	15	mJ	I _D = 2.7A, 10 ⁴ cycles	
		-	-	20	mJ	I _D = 3.2A, 10 cycles ⁵⁾	
Channel 7-10							
Repetitive Clamping Energy	E _{AR}	-	-	4	mJ	I _D = 0.7A, 10 ⁹ cycles	P_7.3.6
		-	-	4	mJ	I _D = 1.4A, 10 ⁴ cycles	
		-	-	5	mJ	I _D = 1.7A, 10 cycles ⁵⁾	

Power Outputs

Table 7 Electrical Characteristics: Power Outputs (cont'd)

$3.0V < V_{CC} < 5.5V$; $4.5V < V_{DD} < 5.5V$, $T_j = -40^\circ\text{C}$ to $+150^\circ\text{C}$, all voltages with respect to ground, positive current flowing into pin (unless otherwise specified)

Parameter	Symbol	Values			Unit	Note or Test Condition	Number
		Min.	Typ.	Max.			
Leakage Current							
Output Leakage Current in standby mode, Channel 1 to 4	I_{Doff}	-	-	3	μA	$V_{\text{DS}} = 13.5\text{V}$, $V_{\text{DD}} = 5\text{V}$, $T_j = 85^\circ\text{C}$ ¹⁾	P_7.3.7
		-	-	8	μA	$V_{\text{DS}} = 13.5\text{V}$, $V_{\text{DD}} = 5\text{V}$, $T_j = 150^\circ\text{C}$	
Output Leakage Current in standby mode, Channel 5 to 6	I_{Doff}	-	-	6	μA	$V_{\text{DS}} = 13.5\text{V}$, $V_{\text{DD}} = 5\text{V}$, $T_j = 85^\circ\text{C}$ ¹⁾	P_7.3.8
		-	-	12	μA	$V_{\text{DS}} = 13.5\text{V}$, $V_{\text{DD}} = 5\text{V}$, $T_j = 150^\circ\text{C}$	
Output Leakage Current in standby mode, Channel 7 to 10	I_{Doff}	-	-	2	μA	$V_{\text{DS}} = 13.5\text{V}$, $V_{\text{DD}} = 5\text{V}$, $T_j = 85^\circ\text{C}$ ¹⁾	P_7.3.9
		-	-	5	μA	$V_{\text{DS}} = 13.5\text{V}$, $V_{\text{DD}} = 5\text{V}$, $T_j = 150^\circ\text{C}$	
Clamping Voltage							
Output Clamping Voltage, Channel 1 to 10	V_{DScl}	45	55	60	V	-	P_7.3.10
Timing							
Output Switching Frequency	f_{OUTx}	-	-	20	kHz	¹⁾ resistive load, duty cycle > 25%	P_7.3.11
Turn-on Time	t_{dON}	-	5	10	μs	$V_{\text{DS}} = 20\%$ of V_{batt} $V_{\text{batt}} = 13.5\text{V}$, $I_{\text{DS1}} \text{ to } I_{\text{DS6}} = 1\text{A}$, $I_{\text{DS7}} \text{ to } I_{\text{DS10}} = 0.5\text{A}$, resistive load	P_7.3.12
Turn-off Time	t_{dOFF}	-	5	10	μs	$V_{\text{DS}} = 80\%$ of V_{batt} $V_{\text{batt}} = 13.5\text{V}$, $I_{\text{DS1}} \text{ to } I_{\text{DS6}} = 1\text{A}$, $I_{\text{DS7}} \text{ to } I_{\text{DS10}} = 0.5\text{A}$, resistive load	P_7.3.13

1) Parameter is not subject to production test, specified by design.

2) Either one of the values has to be considered as worst case limitation. Cumulative scenario and wide range of operating conditions are treated in the Application Note "Switching Inductive Loads - TLE8110 addendum".

Power Outputs

- 3) This lifetime statement is an anticipation based on an extrapolation of Infineon's qualification test results. The actual lifetime of a component depends on its form of application and type of use etc. and may deviate from such statement. The lifetime statement shall in no event extend the agreed warranty period.
- 4) Triangular Pulse Shape (inductance discharge): $I_D(t) = I_D(0) \cdot (1 - t / t_{pulse})$; $0 < t < t_{pulse}$.
- 5) Repetitive operation not allowed. Starting T_j must be kept within specs. In case of high energy pulse an immediate switch-off strategy is recommended.

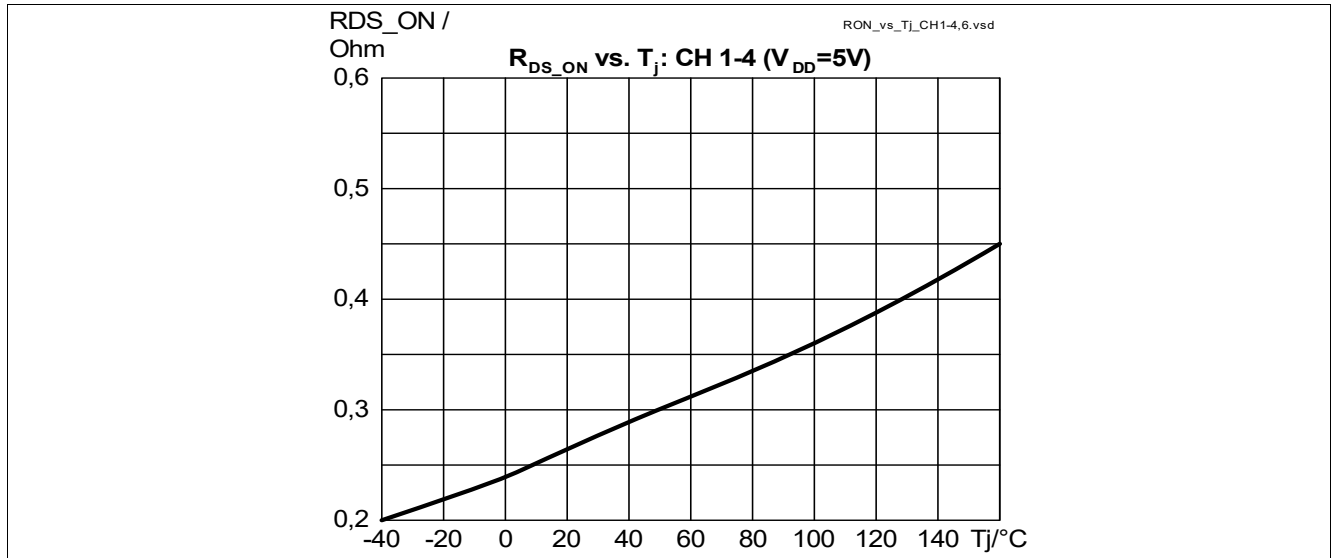

Figure 11 CH 1-4: typical behavior of R_{DS_ON} versus the junction temperature T_j

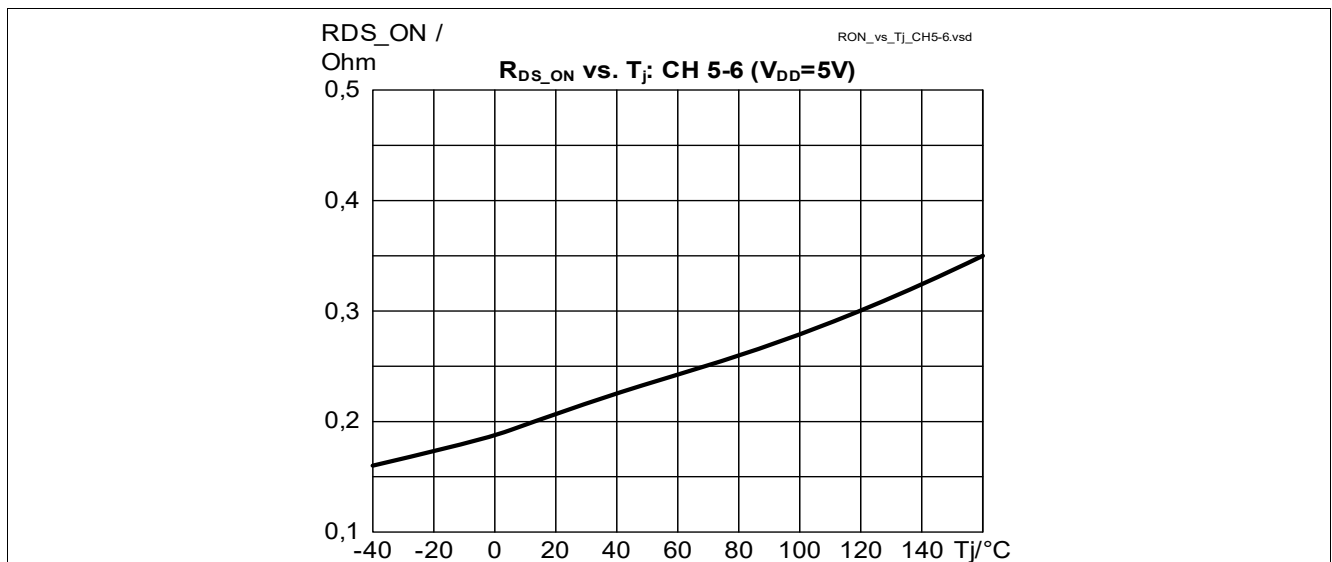

Figure 12 CH5-6: typical behavior of R_{DS_ON} versus the junction temperature T_j

Power Outputs

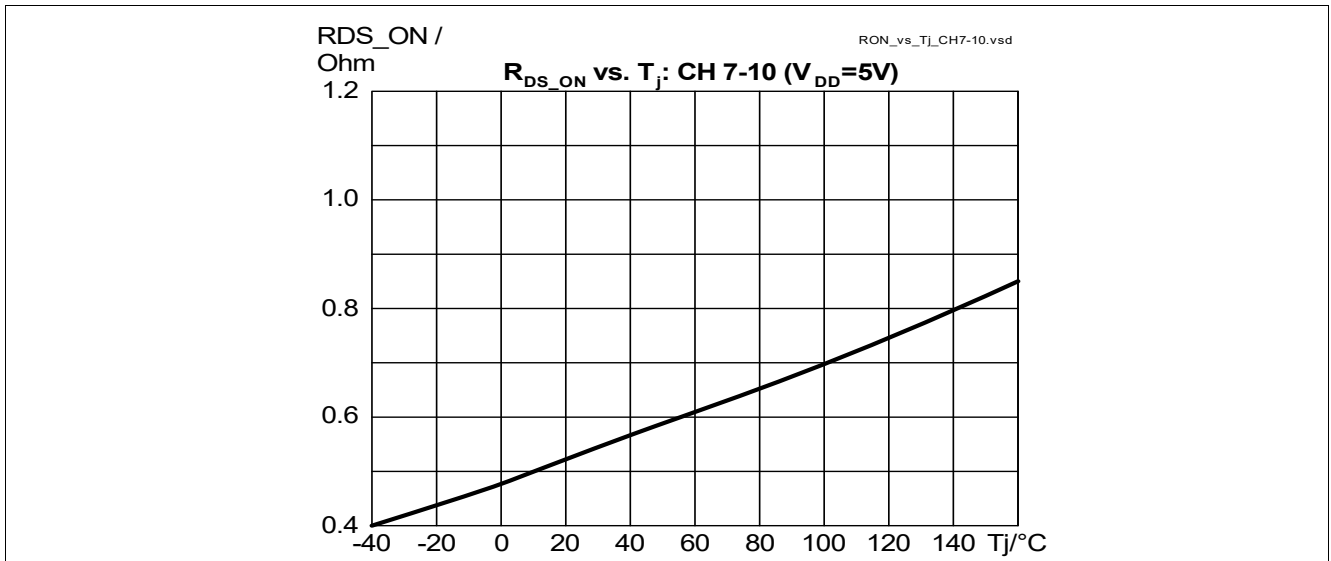

Figure 13 CH7-10: typical behavior of R_{DS_ON} versus the junction temperature T_j

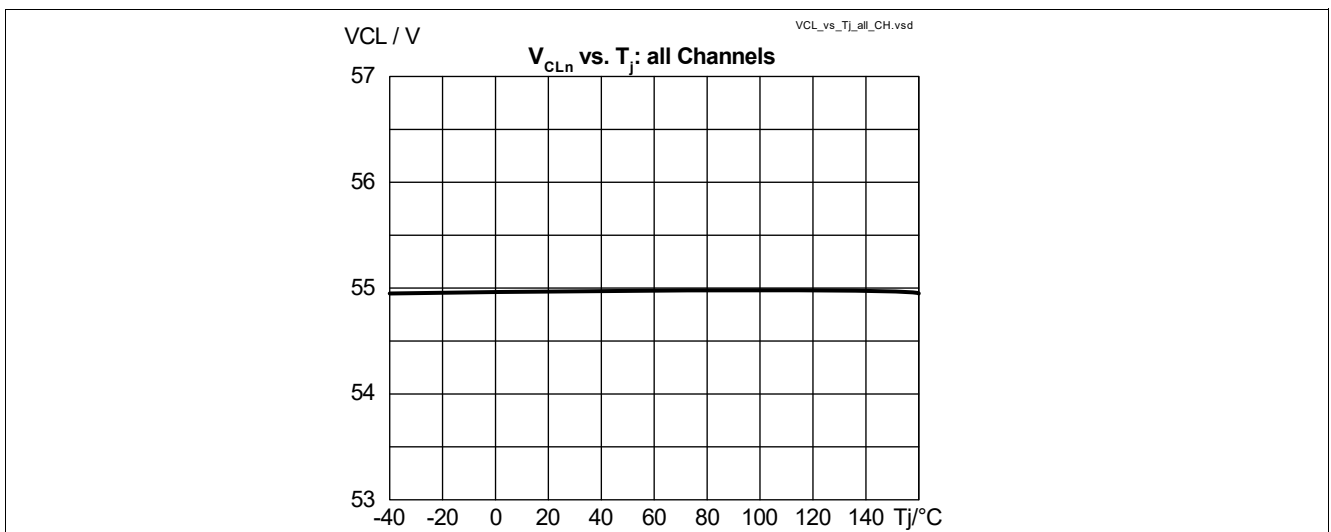

Figure 14 All Channels: typical behavior of the clamping voltage versus the junction temperature

Power Outputs

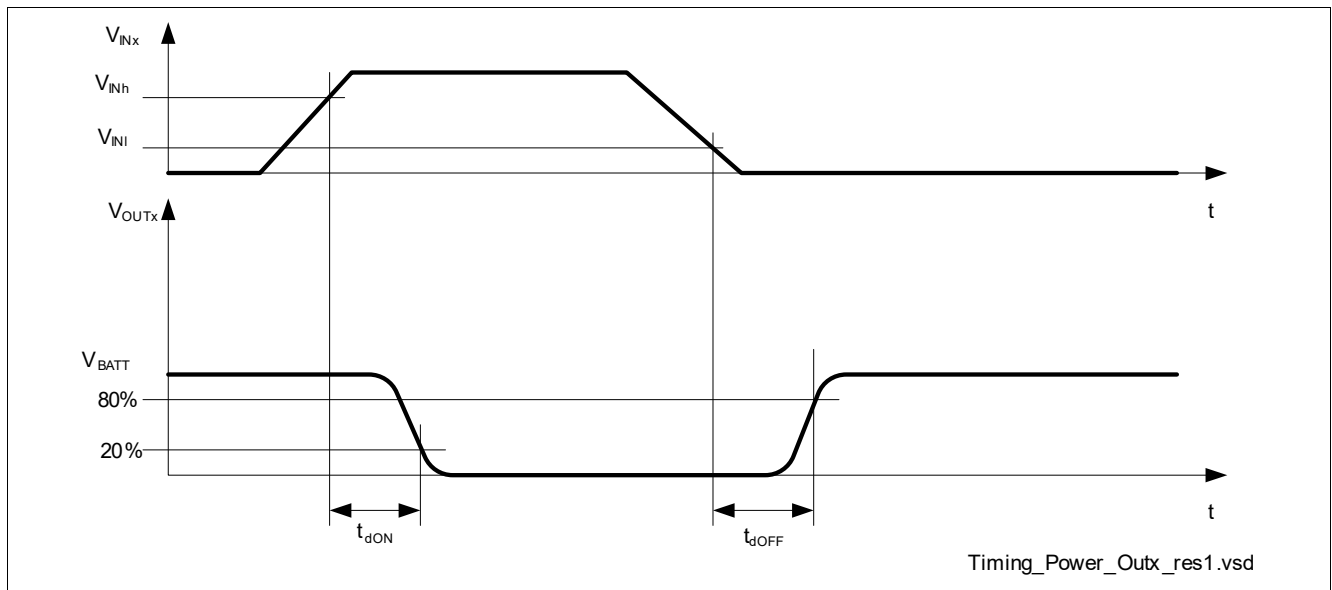

Figure 15 Timing of Output Channel switching (resistive load)

7.4 Parallel Connection of the Power Stages

The TLE8110ED is equipped with a structure which improves the capability of parallel-connected channels. The device can be “informed” via the PMx.PMx - bits (see chapter “Control of the device”) which of the channels are connected in parallel. The input channels can be mapped to the parallel connected output channels in order to apply the PWM signals. This feature allows a flexible adaptation to different load situations within the same hardware setup.

In case of overload the ground current and the power dissipation is increasing. The application has to take into account that all maximum ratings are observed (e.g. operating temperature T_J and total ground current I_{GND} , see Maximum Ratings). In case of parallel connection of channels with or w/o PM-bit set, the defined maximum clamping energy must not be exceeded.

All stages are switched on and off simultaneously. The μC has to ensure that the stages which are connected in parallel have always the same state (on or off). The PM-bit should be set according to the parallel connected power stages in order to achieve the best possible performance.

The PM-bit is set to its default value in case of a Reset event (Reset pin Low or at Digital Supply undervoltage), that means the improved Parallel Mode is no longer active. In the event of reset the channels will be switched off causing the clamping energy to be dissipated with low performance of the current sharing as without PM-bit set, for more details please refer to the Application Note *Switching Inductive Loads - TLE8110 addendum*.

The performance during parallel connection of channels is specified by design and not subject to the production test. All channels at the same junction temperature level.

ON-Resistance

The typical ON-Resistance $R_{DSsum(typ)}$ of parallel connected channels is given by:

$$R_{DSsum(typ)} = \left[\frac{1}{R_{DSon, n(typ)}} + \frac{1}{R_{DSon, n+1(typ)}} \right]^{-1} \quad (7.2)$$

Power Outputs

Table 8 Performance ^{1) 2) 3) 4)} in case of Parallel Connection of Channels: related PM-Bit set

Parameter	Symbol	Channels in Parallel			Unit	Conditions	Number
		2x	3x	4x			
Channel Group 1-4							
Maximum overall current before reaching lower limit threshold	$I_{Dsum(low)}$	5.1	7.6	10.1	A		P_7.4.1
Maximum overall Repetitive Clamping Energy	E_{ARsum}	37	–	–	mJ	$I_D = 1.0A$, 10^9 cycles	P_7.4.2
		17	38	69	mJ	$I_D = 1.75A$, 10^9 cycles	
		–	23	42	mJ	$I_D = 2.5A$, 10^9 cycles	
		–	–	33	mJ	$I_D = 3.0A$, 10^9 cycles	
Channel Group 5-6							
Maximum overall current before reaching lower limit threshold	$I_{Dsum(low)}$	7.2	–	–	A	–	P_7.4.3
Maximum overall Repetitive Clamping Energy	E_{ARsum}	43	–	–	mJ	$I_D = 1.3A$, 10^9 cycles	P_7.4.4
		21	–	–	mJ	$I_D = 2.2A$, 10^9 cycles	
Channel Group 7-10							
Maximum overall current before reaching lower limit threshold	$I_{Dsum(low)}$	3.3	5.0	6.6	A	–	P_7.4.5
Maximum overall Repetitive Clamping Energy	E_{ARsum}	15	–	–	mJ	$I_D = 0.7A$, 10^9 cycles	P_7.4.6
		6	15	30	mJ	$I_D = 1.2A$, 10^9 cycles	
		–	9	18	mJ	$I_D = 1.6A$, 10^9 cycles	
		–	–	11	mJ	$I_D = 2.1A$, 10^9 cycles	

- 1) The performance during parallel connection of channels is specified by design and not subject to the production test.
- 2) Homogenous power distribution over all channels (all power stages equally heated), dependent on cooling set-up.
- 3) This lifetime statement is an anticipation based on an extrapolation of Infineon's qualification test results. The actual lifetime of a component depends on its form of application and type of use etc. and may deviate from such statement. The lifetime statement shall in no event extend the agreed warranty period.
- 4) Triangular Pulse Shape (inductance discharge): $I_D(t) = I_D(0) \cdot (1 - t / t_{pulse})$; $0 < t < t_{pulse}$.

Power Outputs

Table 9 Performance ^{1) 2) 3) 4)} in case of Parallel Connection of Channels: related PM-Bit NOT set

Parameter	Symbol	Channels in Parallel			Unit	Conditions	Number
		2x	3x	4x			
Channel Group 1-4							
Maximum overall current before reaching lower limit threshold	$I_{Dsum(low)}$	5.1	7.6	10.1	A		P_7.5.1
Maximum overall Repetitive Clamping Energy	E_{ARsum}	18	–	–	mJ	$I_D = 1.0A$, 10^9 cycles	P_7.5.2
		8	13	19	mJ	$I_D = 1.75A$, 10^9 cycles	
		–	8	11	mJ	$I_D = 2.5A$, 10^9 cycles	
		–	–	9	mJ	$I_D = 3.0A$, 10^9 cycles	
Channel Group 5-6							
Maximum overall current before reaching lower limit threshold	$I_{Dsum(low)}$	7.2	–	–	A	–	P_7.5.3
Maximum overall Repetitive Clamping Energy	E_{ARsum}	22	–	–	mJ	$I_D = 1.3A$, 10^9 cycles	P_7.5.4
		11	–	–	mJ	$I_D = 2.2A$, 10^9 cycles	
Channel Group 7-10							
Maximum overall current before reaching lower limit threshold	$I_{Dsum(low)}$	3.3	5.0	6.6	A	–	P_7.5.5
Maximum overall Repetitive Clamping Energy	E_{ARsum}	7	–	–	mJ	$I_D = 0.7A$, 10^9 cycles	P_7.5.6
		3	4	7	mJ	$I_D = 1.2A$, 10^9 cycles	
		–	3	4	mJ	$I_D = 1.6A$, 10^9 cycles	
		–	–	3	mJ	$I_D = 2.1A$, 10^9 cycles	

- 1) The performance during parallel connection of channels is specified by design and not subject to the production test.
- 2) Homogenous power distribution over all channels (all power stages equally heated), dependent on cooling set-up.
- 3) This lifetime statement is an anticipation based on an extrapolation of Infineon's qualification test results. The actual lifetime of a component depends on its form of application and type of use etc. and may deviate from such statement. The lifetime statement shall in no event extend the agreed warranty period.
- 4) Triangular Pulse Shape (inductance discharge): $I_D(t) = I_D(0) \cdot (1 - t / t_{pulse})$; $0 < t < t_{pulse}$.

Diagnosis

8 Diagnosis

8.1 Diagnosis Description

The TLE8110ED provides diagnosis information about the device and about the load. Following diagnosis flags have been implemented for each channel:

Diagnosis ¹⁾	Symbol	DRn[1:0]x ²⁾	Device reaction	Confirmation Procedure ³⁾
Short to Ground	SCG	00 _B	-	-
No Fault	OK	11 _B	-	-
Open Load	OL	01 _B	-	Chapter 8.1.1
Overcurrent/ Overtemperature	OCT	10 _B	Switch-off of related channel	Chapter 8.1.2

1) No priority scheme is implemented for the diagnosis detection, any new diagnosis entry will override the previous one.

2) Diagnosis Register (A/B banks) bit configuration, see [Chapter 12.3.2.1](#).

3) For some diagnosis a confirmation procedure is required for a safe operation of the device, refer to [Figure 16](#).

Updating of the Diagnosis is based on a filter-dependent standard delay time (t_d) of 220 μ s max. This value is set as a default. Refer to [Figure 17](#) for details.

If SCG or OL condition is asserted and before the Diagnosis Delay Time (t_d) is elapsed a condition change occurs, OL-to-SCG or SCG-to-OL, filter timer is not reset and latest condition before t_d expiration will be stored into the diagnosis register.

- Application Hint: It is recommended to avoid OFF periods of the channel shorter than $t_{d(max)}$ (220 μ s) in order to ensure the filter time is expired and the correct diagnosis information is stored.
- Application Hint: In specific application cases - such as driving Uni-Polar Stepper Motor - it might be possible, that reverse currents flow for a short time, which possibly can disturb the diagnosis circuit at neighboring channels and cause wrong diagnosis results of those channels. To reduce the possibility, that this effect appears in a certain timing range, the filter time of Channels 7 to 10 can be extended to typ. 2.5ms or typ. 5ms by setting the "Diagnosis Blind Time" - Bits (DBTx). If Channels 7 to 10 are used for driving loads causing reverse currents, they influence each other and additionally might affect Channels 5 and 6. It is recommended to use the channels 7 + 8 and 9 + 10 as pairs for anti-parallel control signals, such as for the stepper motors. For logic setting details, see chapter "Control of the Device".

8.1.1 Open Load diagnosis

If an OL is read out of the Diagnosis Register, the following procedure is required in order to confirm the channel status and ensure a safe operation of the device:

After reading the OL [01_B] in the diagnosis register ([Chapter 12.3.2](#))

1. Switch-OFF for $t \geq t_{d(max)}$ the related channel (via serial or direct control, see ([Chapter 12.3.3](#)) and ([Chapter 12.3.4](#)),
2. Read again the diagnosis register
 - a) If OL is confirmed Then take actions according to system implementation,
3. Continue normal operation.

Diagnosis

Refer to [Figure 16](#) for the procedure flow-chart.

8.1.2 Overcurrent / Overtemperature diagnosis

After an OCT assertion the related channel is switched OFF for safety reasons. If an OCT is read out of the Diagnosis Register, the following procedure is required in order to confirm the channel status and ensure a safe operation of the device:

After reading the OCT [10_B] in the diagnosis register ([Chapter 12.3.2](#))

1. Set related bit DEVS.DCCx = 0 to disable OFF-diagnosis, see ([Chapter 12.3.6](#)),
2. Clear the Diagnosis issuing a DCC.DRxCL command, see ([Chapter 12.3.2](#)),
3. Switch-ON for $t \geq t_{OFFcl_l(max)}$ the related channel,
4. Read again the diagnosis register
 - a) If OCT is confirmed Then take actions according to system implementation,
5. Set related bit DEVS.DCCx = 1 to enable OFF-diagnosis,
6. Continue normal operation.

Refer to [Figure 16](#) for the procedure flow-chart.

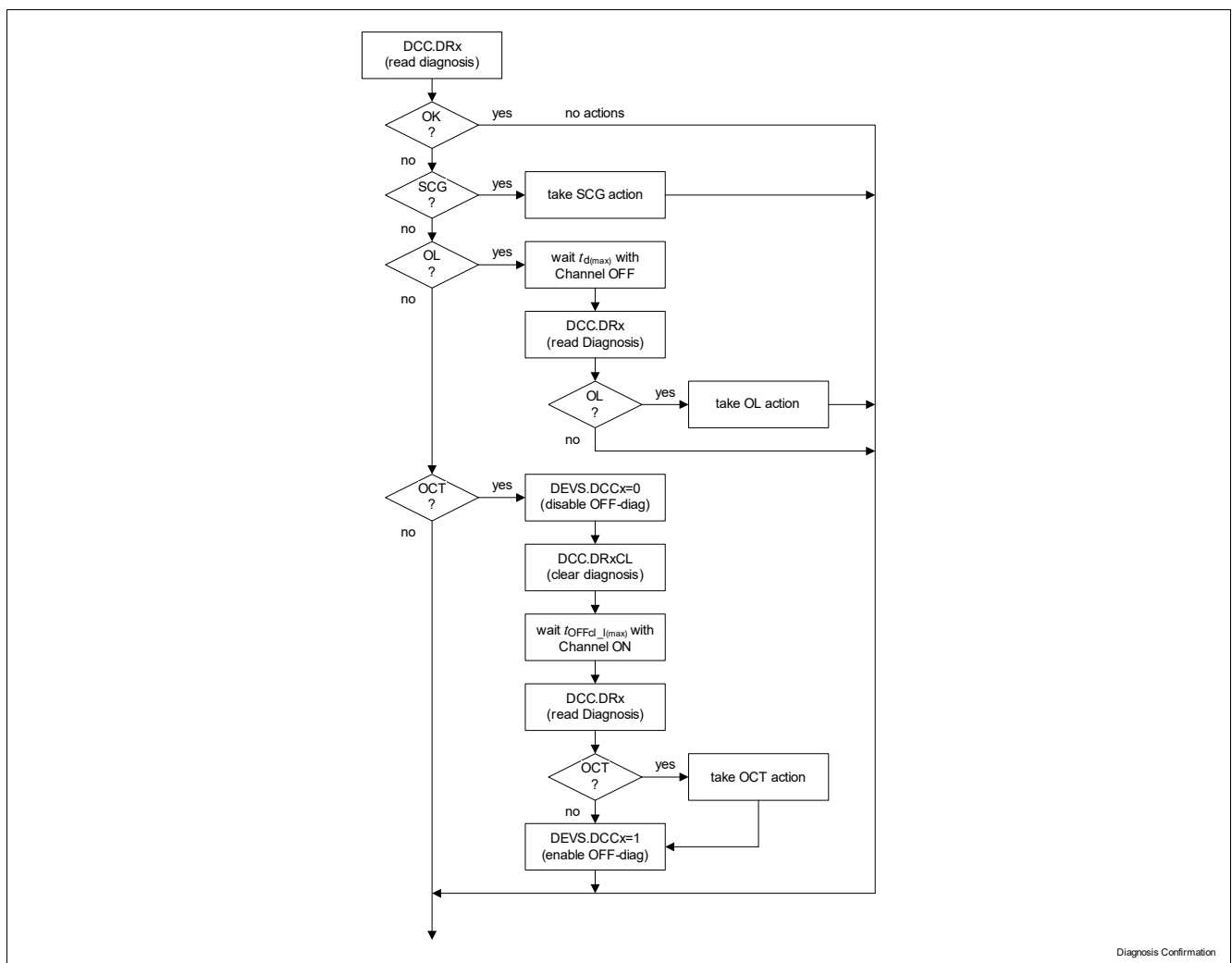

Figure 16 Diagnosis Confirmation procedure

Diagnosis

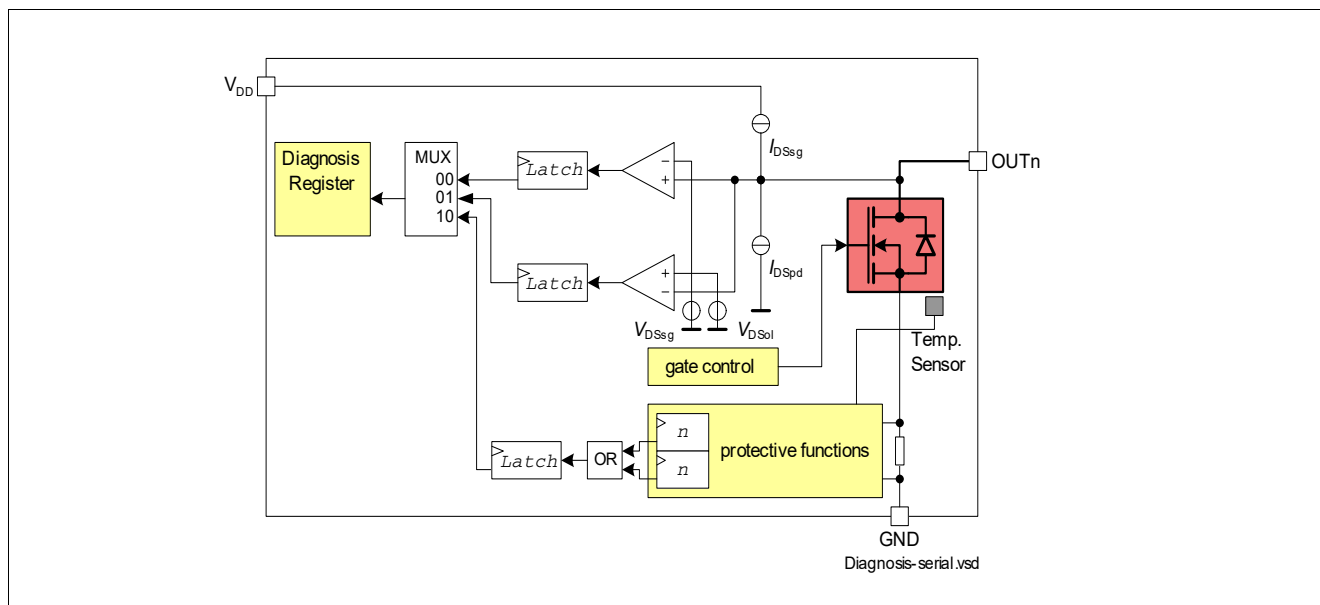

Figure 17 Block Diagram of Diagnosis

8.2 Electrical Characteristics Diagnosis

Table 10 Electrical Characteristics: Diagnosis

$3.0V < V_{CC} < 5.5V$; $4.5V < V_{DD} < 5.5V$, $T_j = -40^{\circ}C$ to $+150^{\circ}C$, all voltages with respect to ground, positive current flowing into pin (unless otherwise specified)

Parameter	Symbol	Values			Unit	Note or Test Condition	Number
		Min.	Typ.	Max.			
Open Load Diagnosis							
Open load detection threshold voltage	V_{Dsol}	2.00	2.60	3.20	V	-	P_8.2.1
Output pull-down diagnosis current per channel (low level)	I_{Dpd}	50	90	150	μA	$V_{DS} = 13.5 V$	P_8.2.2
Open Load Diagnosis Delay Time (all channels)	t_d	100	-	220	μs	DEVS.DBT1 = 0 DEVS.DBT2 = 1 or 0	P_8.2.3
Channel 7-10: Open Load Diagnosis Delay Time “Diagnosis Blind Time” see chapter “Control of the device”, Figure 18 , Figure 19	t_d	1.65	2.5	3.45	ms	DEVS.DBT1 = 1 DEVS.DBT2 = 0	P_8.2.4 a) b)
		3.3	5	7.3	ms	DEVS.DBT1 = 1 DEVS.DBT2 = 1	
Short to GND Diagnosis							
Short to ground detection threshold voltage	V_{Dsg}	1.00	1.50	2.00	V	-	P_8.2.5
Output diagnosis current for short to ground per channel (low level)	I_{Dsg}	-150	-100	-50	μA	$V_{DS} = 0V$	P_8.2.6
Short to GND Diagnosis Delay Time	t_d	100	-	220	μs	DEVS.DBT1 = 0 DEVS.DBT2 = 1 or 0	P_8.2.7

Diagnosis

Table 10 Electrical Characteristics: Diagnosis

3.0V < V_{CC} < 5.5V; 4.5V < V_{DD} < 5.5V, T_j = -40°C to +150°C, all voltages with respect to ground, positive current flowing into pin (unless otherwise specified)

Parameter	Symbol	Values			Unit	Note or Test Condition	Number
		Min.	Typ.	Max.			
Channel 7-10: Short to GND Diagnosis Delay Time. “Diagnosis Blind Time” see chapter “Control of the device”, Figure 18 , Figure 19	t _d	1.65	2.5	3.45	ms	DEVS.DBT1 = 1 DEVS.DBT2 = 0	P_8.2.8 a) b)
		3.3	5	7.3	ms	DEVS.DBT1 = 1 DEVS.DBT2 = 1	

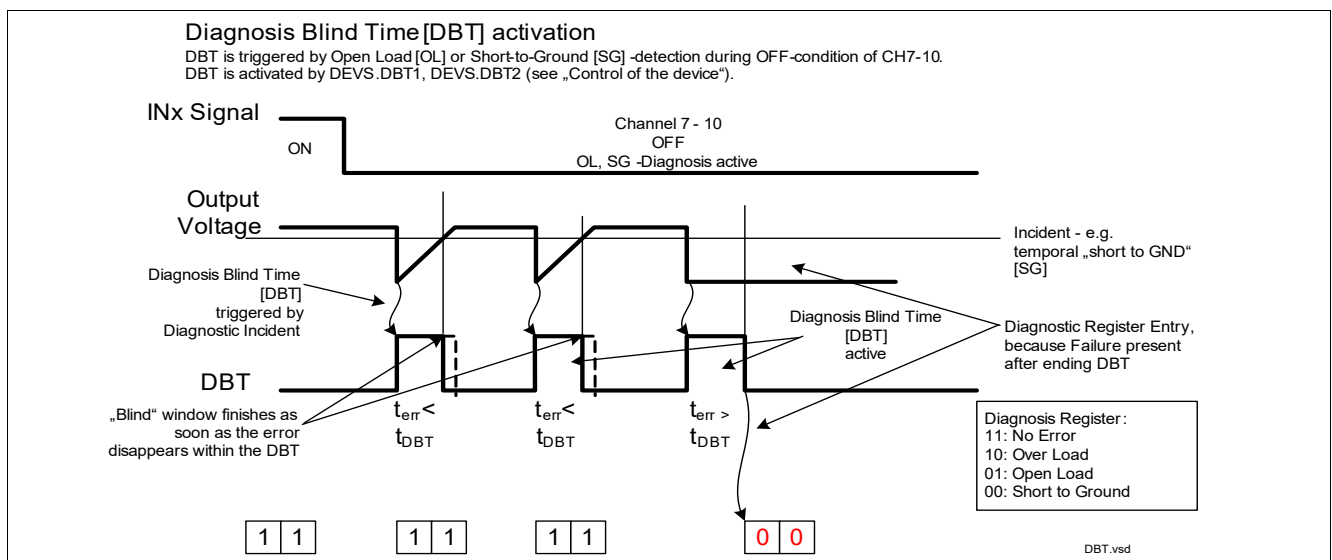

Figure 18 Diagnosis Blind Time

Diagnosis

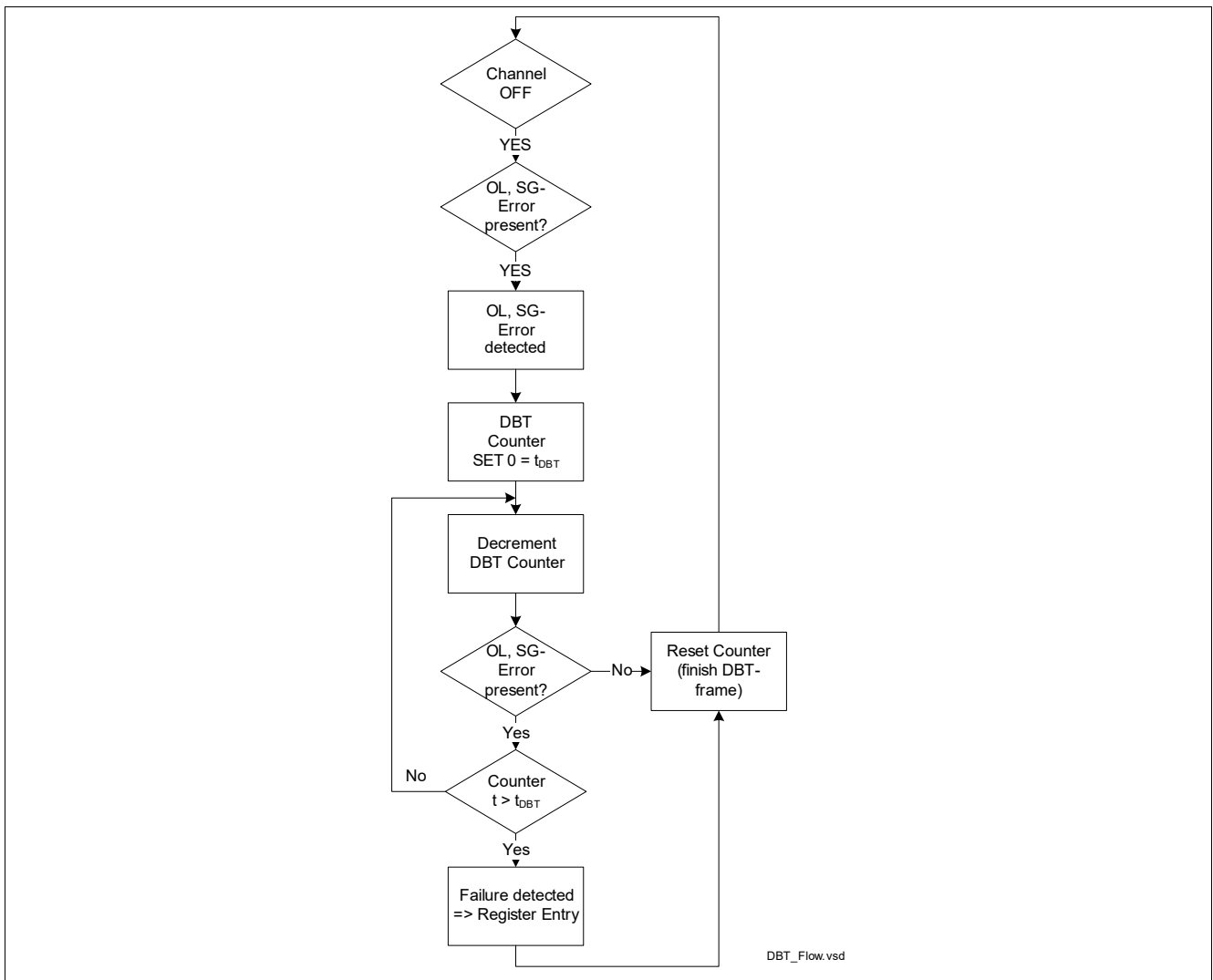

Figure 19 Diagnosis Blind Time - Logic Flow

Parallel Inputs

9 Parallel Inputs

9.1 Description Parallel Inputs

There are 10 input pins available on TLE8110ED to control the output stages.

Each input signal controls the output stages of its assigned channel. For example, IN1 controls OUT1, IN2 controls OUT2, etc.

A “Low”-Signal at INx switches the related Output Channel off. The zener diode protects the input circuit against ESD pulses.

For details about the Boolean operation, refer to the chapter “Control of the device”, for details about timing refer to [Figure 11](#).

9.2 Electrical Characteristics Parallel Inputs

Table 11 Electrical Characteristics: Parallel Inputs

$3.0V < V_{CC} < 5.5V$; $4.5V < V_{DD} < 5.5V$, $T_j = -40^{\circ}C$ to $+150^{\circ}C$, all voltages with respect to ground, positive current flowing into pin (unless otherwise specified)

Parameter	Symbol	Values			Unit	Note or Test Condition	Number
		Min.	Typ.	Max.			
Parallel Inputs							
Low Level of parallel Input pin	V_{INxl}	-0.3	–	$V_{CC} * 0.2$	V	–	P_9.2.1
High Level of Parallel Input pin	V_{INxh}	$V_{CC} * 0.4$	–	V_{CC}	V	–	P_9.2.2
Parallel Input Pin Switching Hysteresis	V_{INxhy} –	15	60	300	mV	¹⁾	P_9.2.3
Input Pin pull-down Current	I_{INxh}	20	40	85	μA	$V_{INx} = 5V$	P_9.2.4 a)
	I_{INxl}	2.4	–	–	μA	$V_{INx} = 0.6V$ ¹⁾	b)

1) Parameter not subject to production test. Specified by design.

Protection Functions

10 Protection Functions

The device provides embedded protective functions. Integrated protection functions are designed to prevent IC destruction under fault conditions described in this Document. Fault conditions are considered “outside” the normal operating range. Protection functions are not designed for continuous repetitive operation.

There is an over load and over temperature protection implemented in the TLE8110ED.

If a protection function becomes active during the write cycle of Diagnosis Information into the Diagnosis Register, the information is latched and stored into the diagnosis register after the write process.

In order to achieve a maximum protection, the affected channel with over current or over temperature (OCT) is switched and latched OFF, channel can be turned ON again after the diagnosis register is cleared ([Chapter 12.3.2](#)).

For the failure condition of Reverse Currents, the device contains a “Reverse Current Protection Comparator” [RCP]. This RCP can optionally be activated by setting the DEVS.RCP Bit.

In case the comparator is activated, it detects a reverse current and switches ON the related output channel. The channel is kept ON up to a reverse current channel dependent threshold I_{RCP_off} . This threshold is defined by regulators target value to keep the output voltage at $>/\sim -0.3V$. If the current exceeds a defined value, the comparator switches OFF and other protection functions are protecting the circuit against reverse current. That means that at higher currents / or in case RCP is de-activated / not activated, the reverse current is flowing through the body diode of the DMOS. In that case, the voltage drops to typically $-0.6V$ according the voltage of the body diode. In case the comparator threshold has been exceeded and the RCP has been switched OFF, the functions remains OFF until the reverse current arrives back to zero reverse current. Only then, the comparator can be activated again after a delay time $t_{RCP_on_delay}$.

This function reduces the un-wanted influence of a reverse current to the analogue part of the circuit (such as the diagnosis). For more details about the functionality, see [Figure 22](#) and [Figure 23](#) and concerning the settings and the related registers, refer to Chapter “Control of the Device”.

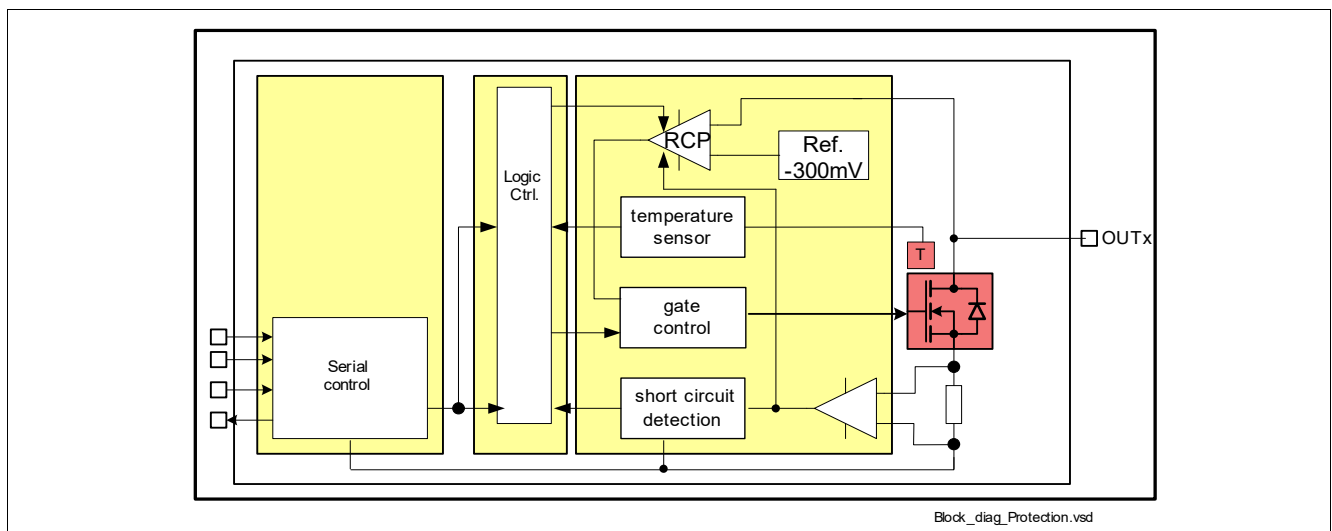

Figure 20 Block Diagram Protection Functions

Protection Functions

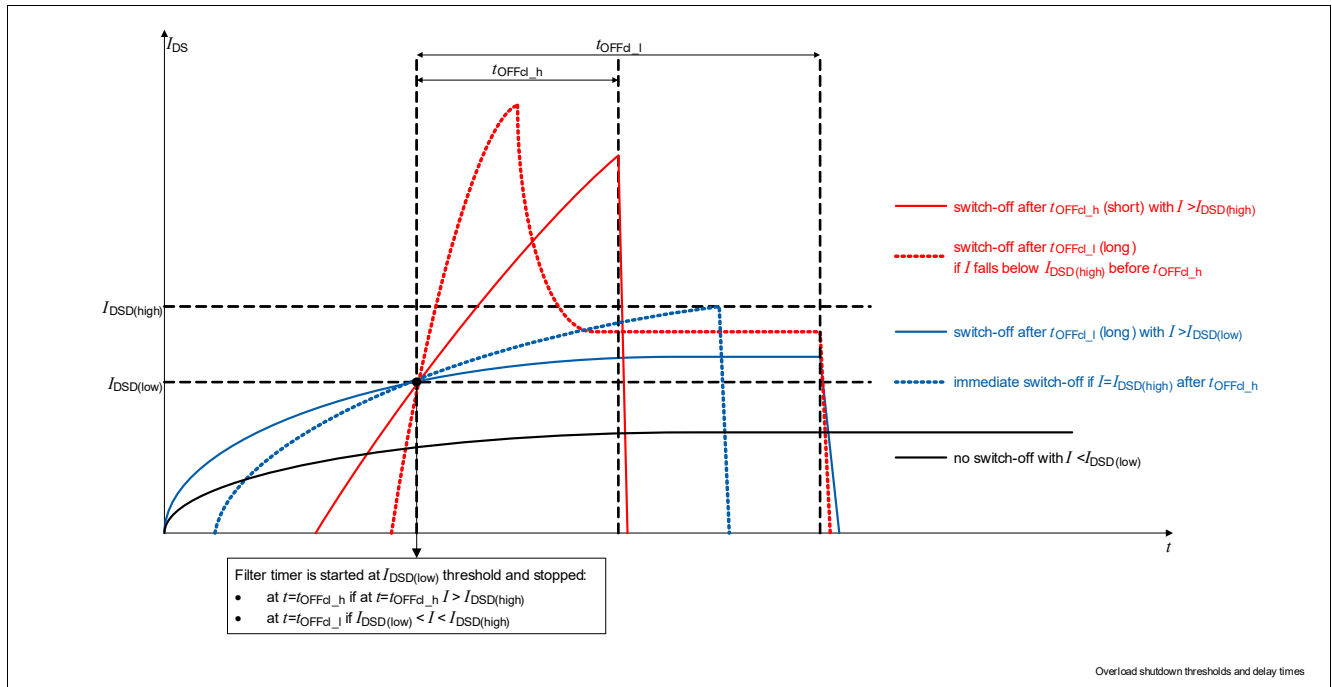

Figure 21 Overload shutdown thresholds and delay times

10.1 Electrical Characteristics Overload Protection Function

Table 12 Electrical Characteristics: Overload Protection Function

$3.0V < V_{CC} < 5.5V$; $4.5V < V_{DD} < 5.5V$, $T_j = -40^{\circ}C$ to $+150^{\circ}C$, all voltages with respect to ground, positive current flowing into pin (unless otherwise specified)

Parameter	Symbol	Values			Unit	Note or Test Condition	Number
		Min.	Typ.	Max.			
Over Current Protection							
Output Current Shut-down Threshold Low (Channel 1 to 4)	$I_{DSD(low)}$	2.6	3.8	5	A	-	P_10.1.1
Output Current Shut-down Threshold Low (Channel 5 to 6)	$I_{DSD(low)}$	3.70	4.85	6.00	A	-	P_10.1.2
Output Current Shut-down Threshold Low (Channel 7 to 10)	$I_{DSD(low)}$	1.7	2.3	2.9	A	-	P_10.1.3
Output Current Shut-down Threshold High (Channel 1 to 4)	$I_{DSD(high)}$	-	$1.5 * I_{DSD(low)}$	-	A	¹⁾	P_10.1.4
Output Current Shut-down Threshold High (Channel 5 to 6)	$I_{DSD(high)}$	-	$1.5 * I_{DSD(low)}$	-	A	¹⁾	P_10.1.5
Output Current Shut-down Threshold High (Channel 7 to 10)	$I_{DSD(high)}$	-	$1.5 * I_{DSD(low)}$	-	A	¹⁾	P_10.1.6
Short Overload shutdown Delay Time (all Channels)	t_{OFFd_h}	5	21	40	μs	valid for "Output Current Threshold High" ¹⁾	P_10.1.7

Protection Functions

Table 12 Electrical Characteristics: Overload Protection Function (cont'd)

$3.0V < V_{CC} < 5.5V$; $4.5V < V_{DD} < 5.5V$, $T_j = -40^\circ\text{C}$ to $+150^\circ\text{C}$, all voltages with respect to ground, positive current flowing into pin (unless otherwise specified)

Parameter	Symbol	Values			Unit	Note or Test Condition	Number
		Min.	Typ.	Max.			
Long Overload shutdown Delay Time (all Channels)	t_{OFFcl}	10	40	70	μs	valid for "Output Current Threshold Low"	P_10.1.8

Over Temperature Protection

Thermal Shut Down Temperature	T_{jSD}	175	190	205	$^\circ\text{C}$	¹⁾	P_10.1.9
Thermal Shut Down Hysteresis	T_{jSDh}	10	-	20	K	¹⁾	P_10.1.10

Reverse Current Protection

Reverse Current Comparator Switch-off Current level CH 1 - 4	I_{RCP_off}	-	-0.9	-	A	DEVS.RCP = 1, $T_j = 25^\circ\text{C}$ ¹⁾	P_10.1.11
Reverse Current Comparator Switch-off Current level CH 5 - 6	I_{RCP_off}	-	-0.6	-	A	DEVS.RCP = 1, $T_j = 25^\circ\text{C}$ ¹⁾	P_10.1.12
Reverse Current Comparator Switch-off Current level CH 7 - 10	I_{RCP_off}	-	-0.45	-	A	DEVS.RCP = 1, $T_j = 25^\circ\text{C}$ ¹⁾	P_10.1.13
Reverse Current Comparator switch on delay time	$t_{RCP_on_delay}$	-	24	-	μs	DEVS.RCP = 1, $T_j = 25^\circ\text{C}$ ¹⁾	P_10.1.14

1) Parameter not subject to production test. Specified by design.

Protection Functions

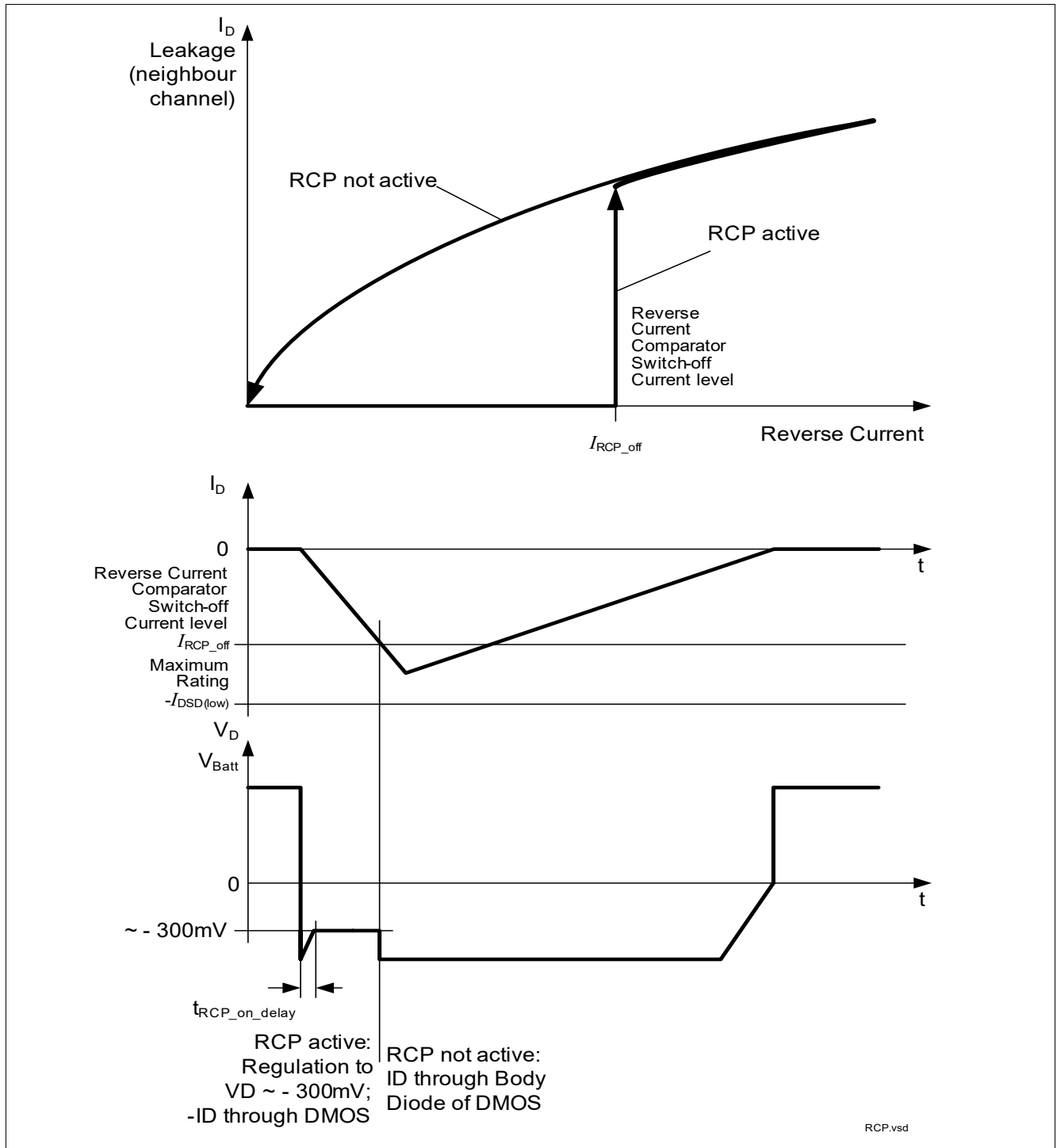

Figure 22 Reverse Current Protection Comparator 6

Protection Functions

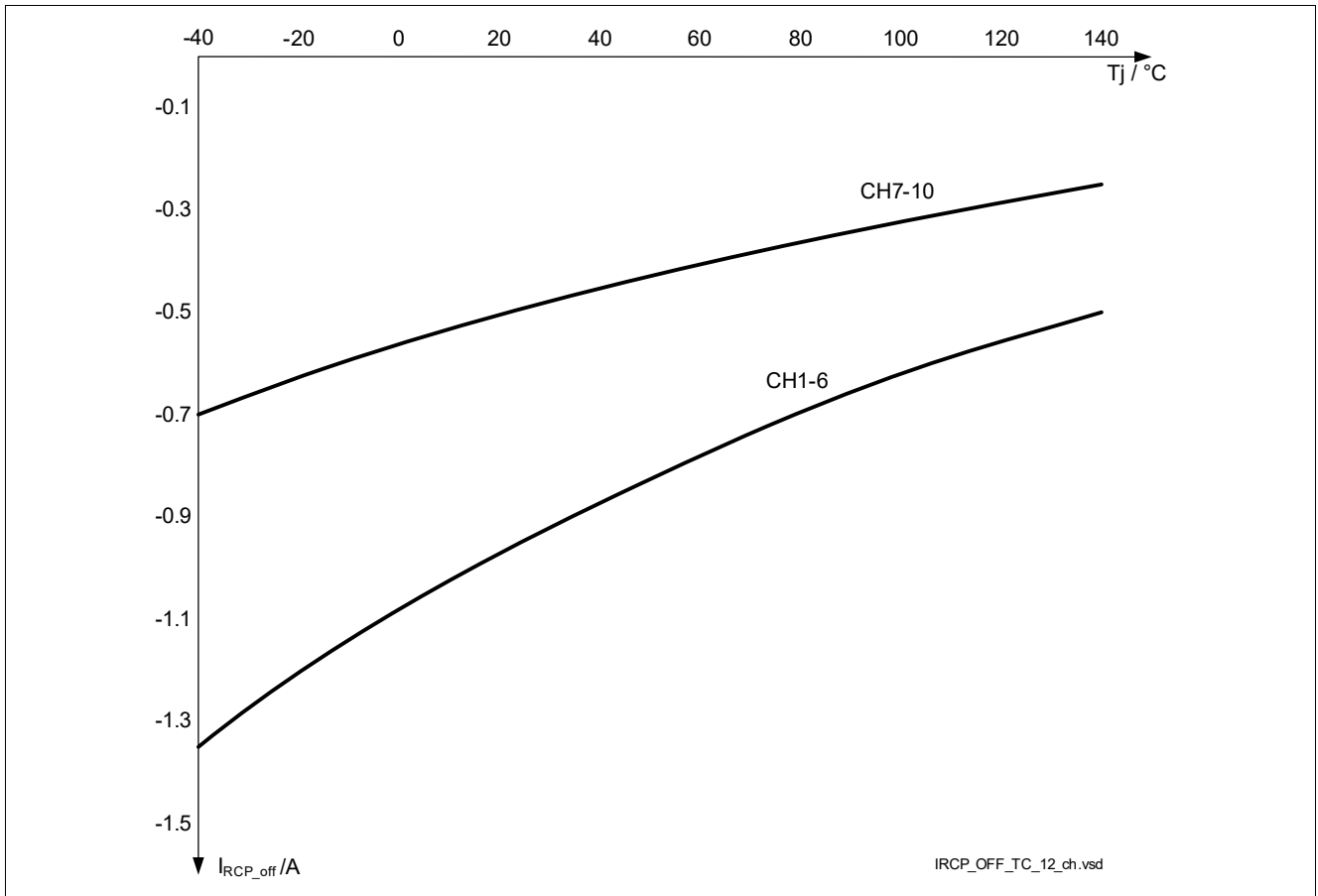

Figure 23 Reverse Current Protection Comparator (typical behavior vs. junction temperature)

16 bit SPI Interface

11 16 bit SPI Interface

11.1 Description 16 bit SPI Interface

The diagnosis and control interface is based on a serial peripheral interface (SPI).

The SPI is a full duplex synchronous serial slave interface, which uses four lines: S_SO, S_SI, S_CLK and $\overline{S_CS}$. Data is transferred by the lines S_SI and S_SO at the data rate given by S_CLK. The falling edge of $\overline{S_CS}$ indicates the beginning of a data access. Data is sampled in on line S_SI at the falling edge of S_CLK and shifted out on line SO at the rising edge of SCLK. Each access must be terminated by a rising edge of $\overline{S_CS}$. A modulo 8 counter ensures that data is taken only, when a multiple of 8 bit has been transferred. If in one transfer cycle not a multiple of 8 bits have been counted, the data frame is ignored. The interface provides daisy chain capability.

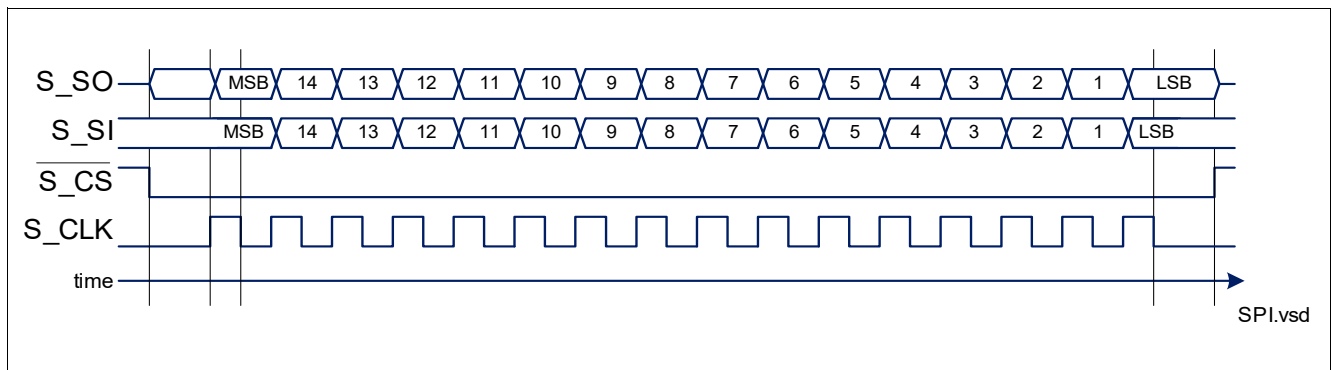

Figure 24 16 bit SPI Interface

The SPI protocol is described in Chapter “Control of the device”. Concerning Reset of the SPI, please refer to the chapter “Reset”.

11.2 Timing Diagrams

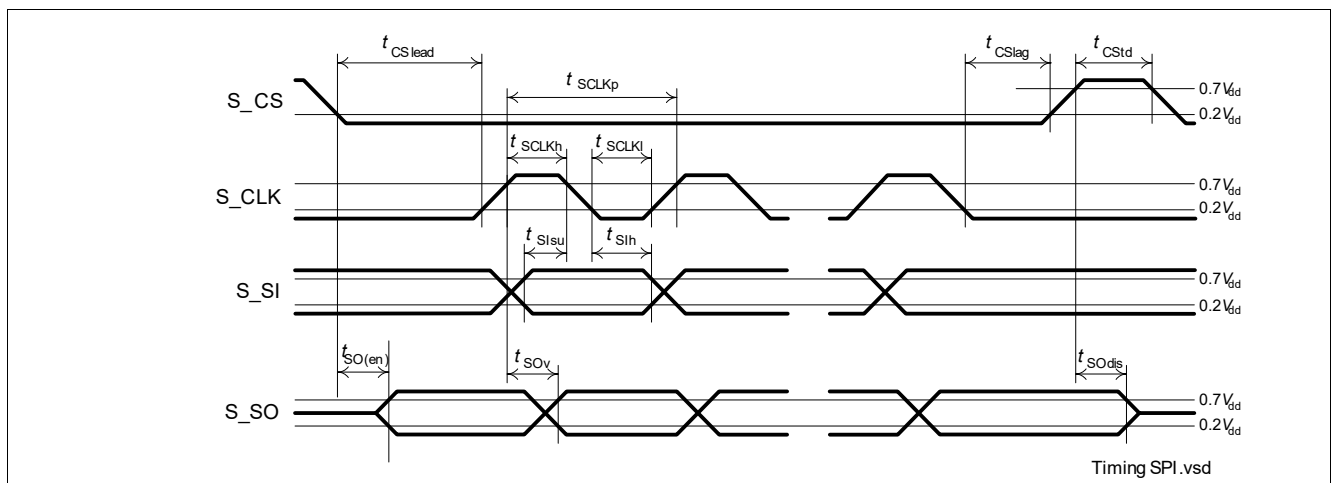

Figure 25 SPI timing diagram

16 bit SPI Interface

11.3 Electrical Characteristics 16 bit SPI Interface

Table 13 Electrical Characteristics: 16 bit SPI Interface

3.0V < V_{CC} < 5.5V; 4.5V < V_{DD} < 5.5V, T_j = -40°C to +150°C, all voltages with respect to ground, positive current flowing into pin (unless otherwise specified)

Parameter	Symbol	Values			Unit	Note or Test Condition	Number
		Min.	Typ.	Max.			
Input Characteristics ($\overline{\text{CS}}$, SCLK, SI)							
L level of pin $\overline{\text{S_CS}}$, S_CLK, S_SI,	V _{S_CSI} V _{S_CLKI} V _{S_SII}	-0.3	-	V _{CC} * 0.2	V	-	P_11.3.1
H level of pin $\overline{\text{S_CS}}$, S_CLK, S_SI,	V _{S_CSh} V _{S_CLKh} V _{S_Slh}	V _{CC} * 0.4	-	V _{CC}	V	-	P_11.3.2
Hysteresis Input Pins	V _{S_CShy} V _{S_CLKhy} V _{S_Slhy}	20	100	300	mV	-	P_11.3.3
Input Pin pull-down Current S_CLK, S_SI	I _{S_CLKh} I _{S_Slh}	20	40	85	μA	V _{IN} = 5V	P_11.3.4 a)
	I _{S_CLKI} I _{S_SlI}	2.4	-	-	μA	V _{IN} = 0.6V ¹⁾	b)
Input Pin pull-up Current $\overline{\text{S_CS}}$	I _{S_CSh}	-4	-	-	μA	V _{S_CS} = 2V, V _{CC} = 5V	P_11.3.5 a)
	I _{S_CSI}	-20	-40	-85	μA	V _{S_CS} = 0V, V _{CC} = 5V	b)
Output Characteristics (SO)							
L level output voltage	V _{S_SoI}	0	-	0.4	V	I _{S_So} = -2 mA	P_11.3.6
H level output voltage	V _{S_SOh}	V _{CC} - 0.4 V	-	V _{CC}	-	I _{S_So} = 1.5 mA	P_11.3.7
Output tristate leakage current	I _{S_Sooff}	-10	-	10	μA	V _{S_So} = V _{CC}	P_11.3.8
Timings							
Serial clock frequency	f _{S_CLK}	0	-	5	MHz	C _L = 50 pF ¹⁾	P_11.3.9
Serial clock period	t _{S_CLK(P)}	200	-	-	ns	¹⁾	P_11.3.10
Serial clock high time	t _{SCLK(H)}	50	-	-	ns	¹⁾	P_11.3.11
Serial clock low time	t _{SCLK(L)}	50	-	-	ns	¹⁾	P_11.3.12
Enable lead time (falling $\overline{\text{CS}}$ to rising SCLK)	t _{CS(lead)}	250	-	-	ns	¹⁾	P_11.3.13
Enable lag time (falling SCLK to rising $\overline{\text{CS}}$)	t _{CS(lag)}	250	-	-	ns	¹⁾	P_11.3.14
Transfer delay time (rising $\overline{\text{CS}}$ to falling $\overline{\text{CS}}$)	t _{CS(td)}	250	-	-	ns	¹⁾	P_11.3.15

16 bit SPI Interface

Table 13 Electrical Characteristics: 16 bit SPI Interface (cont'd)

3.0V < V_{CC} < 5.5V; 4.5V < V_{DD} < 5.5V, T_j = -40°C to +150°C, all voltages with respect to ground, positive current flowing into pin (unless otherwise specified)

Parameter	Symbol	Values			Unit	Note or Test Condition	Number
		Min.	Typ.	Max.			
Data setup time (required time SI to falling SCLK)	t _{SI(su)}	20	–	–	ns	¹⁾	P_11.3.16
Data hold time (falling SCLK to SI)	t _{SI(h)}	20	–	–	ns	¹⁾	P_11.3.17
Output enable time (falling \overline{CS} to SO valid)	t _{SO(en)}	–	–	200	ns	C _L = 50 pF ¹⁾	P_11.3.18
Output disable time (rising \overline{CS} to SO tri-state)	t _{SO(dis)}	–	–	200	ns	C _L = 50 pF ¹⁾	P_11.3.19
Output data valid time with capacitive load	t _{SO(v)}	–	–	100	ns	C _L = 50 pF ¹⁾	P_11.3.20
Diagnosis Clear-to-Read Idle Time	t _{Didle}	16	–	–	μs	¹⁾	P_11.3.21
Diagnosis Overcurrent-to-Clear Idle Time	t _{OCidle}	12	–	–	μs	¹⁾	P_11.3.22

1) Not subject to production test, specified by design.

Control of the device

12 Control of the device

This chapter describes the SPI-Interface signals, the protocol, registers and commands. Reading this chapter allows the Software Engineer to control the device. The chapter contains also some information about communication safety features of the protocol.

12.1 Internal Clock

The device contains an internal clock oscillator.

Table 14 Electrical Characteristics: Internal Clock

$3.0V < V_{CC} < 5.5V$; $4.5V < V_{DD} < 5.5V$, $T_j = -40^{\circ}C$ to $+150^{\circ}C$, all voltages with respect to ground, positive current flowing into pin (unless otherwise specified)

Parameter	Symbol	Values			Unit	Note or Test Condition	Number
		Min.	Typ.	Max.			
Parallel Inputs							
internal clock oscillator frequency	f_{int_osc}	-	500	-	kHz	1)	

1) Parameter not subject to production test. Specified by design.

12.2 SPI Interface. Signals and Protocol

12.2.1 Description 16 bit SPI Interface Signals

S_CS - Chip Select:

The system micro controller selects the TLE8110ED by means of the S_CS pin. Whenever the pin is in low state, data transfer can take place. When S_CS is in high state, any signals at the S_CLK and S_SI pins are ignored and S_SO is forced into a high impedance state.

S_CS High to Low transition:



- The information to be transferred loaded into the shift register (16-bit Protocol).

S_CS Low to High transition:



- Command decoding is only done, when after the falling edge of CS exactly a multiple (1, 2, 3...) of eight S_CLK signals have been detected. (See Modulo-8 Counter: [Chapter 12.2.4.2](#)).

S_CLK - Serial Clock:

This input pin clocks the internal shift register. The serial input (S_SI) transfers data is shifted into register on the falling edge of S_CLK while the serial output (S_SO) shifts the information out on the rising edge of the serial clock. It is essential that the S_CLK pin is in low state whenever chip select CS makes any transition.

S_SI - Serial Input:

Serial input data bits are shifted in at this pin, the most significant bit first. The bit at the S_SI Pin is read on the falling edge of S_CLK.

S_SO Serial Output:

Data is shifted out serially at this pin, the most significant bit first. S_SO is in high impedance state until the S_CS pin goes to low state. The next bits will appear at the S_SO is in high impedance state until the S_CS goes to low state. The next bits will appear at the S_SO pin following the rising edge of S_CLK.

Control of the device

12.2.2 Daisy Chain

The SPI-Interface of TLE8110ED provides daisy chain capability, see [Chapter 12.2.3.4](#) for more details. In this configuration several devices are activated by the same $\overline{S_CS}$ signal. The S_SI line of one device is connected with the S_SO line of another device (see [Figure 26](#)), which builds a chain. The ends of the chain are connected with the output and input of the master device, S_SO and S_SI respectively. The master device provides the master clock CLK, which is connected to the S_CLK line of each device in the chain. By each clock edge on S_CLK , one bit is shifted into the S_SI . The bit shifted out can be seen at SO . After 16 S_CLK cycles, the data transfer for one device has been finished. In single chip configuration, the $\overline{S_CS}$ line must go high to make the device accept the transferred data. In daisy chain configuration the data shifted out at device 1 has been shifted in to device 2. Example: When using three devices in daisy chain, three times 16 bits have to be shifted through the devices. After that, the $\overline{S_CS}$ line must go high (see [Figure 26](#)).

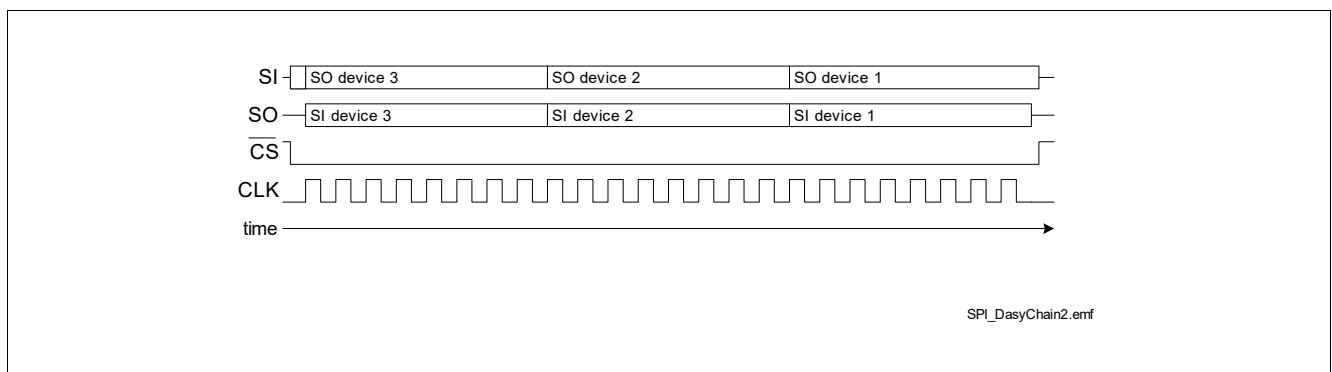

Figure 26 Principle example for Data Transfer in Daisy Chain Configuration

Note: Due to the integrated modulo 8 counter, 8 bit and 16 bit devices can be used in one daisy chain.

12.2.3 SPI Protocol

The device contains two protocol styles which are applied dependent of the used commands. There is the standard 16-bit protocol and the 2x8-bit protocol. Both protocols can appear also be mixed.

12.2.3.1 16-bit protocol

Each cycle where a serial data or command frame is sent to the S_SI of the SPI interface, a data frame is returned at the same time by the S_SO . The content of the S_SO frame is dependent on the previous command which has been sent to S_SI . Read Command ($R/W = R$) returns one cycle later the content of the address register (see [Figure 27](#)).

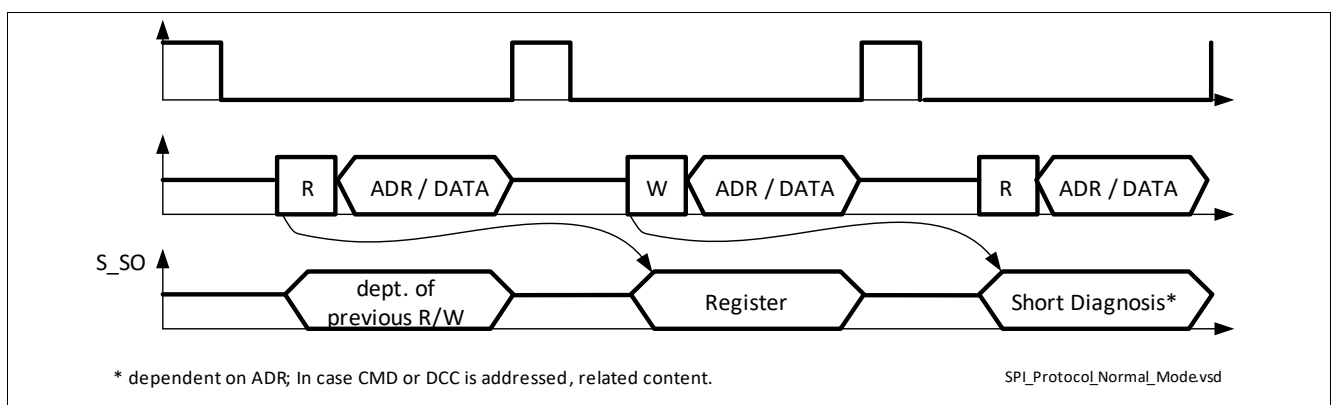
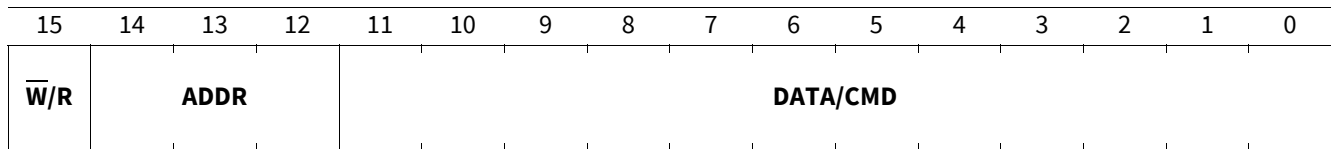

Figure 27 16-bit protocol

Control of the device

16-bit protocol

S_SI Serial Input



S_SO Serial Output

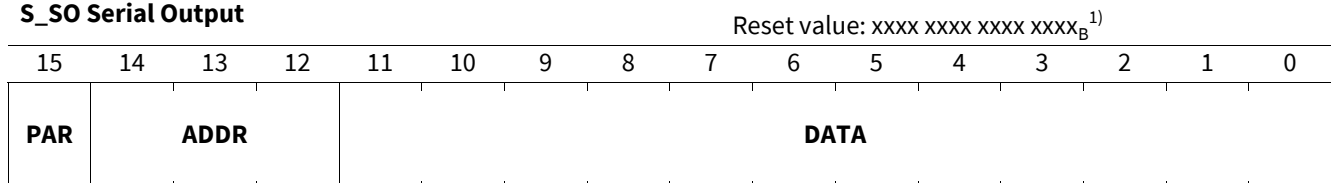

1) after reset a Short Diagnosis and Device Status CMD_CS_DS response is sent, see [Chapter 12.3.1.2](#).

Bit description

Field	Bits	Type	Function
S_SI Serial Input			
$\overline{\text{W/R}}$	15		Write/Read 0 Write register: The register content of the addressed register will be updated after CS low → high transition. After sending a WRITE command, the device returns data according the addressed register, 1 Read register: The register content of the addressed register will be sent in the next frame.
ADDR	[14:12]		ADDR - Address Pointer to register for read and write command.
DATA/CMD	[11:0]		DATA_CMD - Data / Command Data written to or read from register selected by address ADDR.
S_SO Serial Output			
PAR	15		PAR - Parity Bit 0 Even number of '1' in data and address field, 1 Odd number of '1' in data and address field.
ADDR	[14:12]		Address Address which has been addressed.
DATA	[11:0]		Data Content of Address or feedback data.

Note: Reading a register needs two SPI frames. In the first frame the RD command is sent. In the second frame the output at SPI signal SO will contain the requested information. A new command can be executed in the second frame.

Control of the device

12.2.3.2 2x8-bit protocol

Each Cycle where a serial data or command frame is sent to the S_SI of the SPI interface, a data frame is returned at the same time by the S_SO. The content of the S_SO frame is dependent of the previous command which has been sent to S_SI and the content of the actual content of S_SI: The first Upper Byte send to S_SI controls the content of the Lower Byte actual returned by S_SO. The Lower Byte send to S_SI controls the Lower Byte in S_SO of the next frame (see [Figure 28](#)).

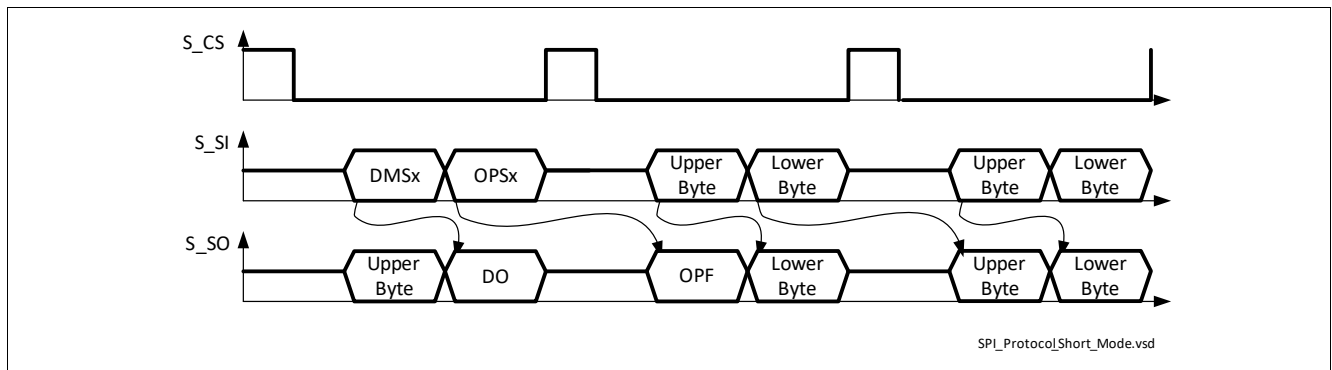

Figure 28 2x8-bit protocol

2x8-bit protocol

S_SI Serial Input

15	14	13	12	11	10	9	8	7	6	5	4	3	2	1	0
Upper Byte								Lower Byte							

S_SO Serial Output

Reset value: xxxx xxxx xxxx xxxx¹⁾

15	14	13	12	11	10	9	8	7	6	5	4	3	2	1	0
Upper Byte								Lower Byte							

1) after reset a Short Diagnosis and Device Status CMD_CSDS response is sent, see [Chapter 12.3.1.2](#).

Bit description

Field	Bits	Type	Function
S_SI Serial Input			
Upper Byte	[15:8]		Upper Byte Contains the command, which is performed after sending 8 bit to S_SI. The action out of this command is affecting the Lower Byte of S_SO of the actual communication frame.
Lower Byte	[7:0]		Lower Byte Contains the command and data, which is performed at the end of the actual communication frame. The action out of this command is affecting the Upper Byte of S_SO of next communication frame.

Control of the device

Bit description

Field	Bits	Type	Function
S_SO Serial Output			
Upper Byte	[15:8]		Upper Byte Contains the data according the command and data in the Lower Byte of the previous communication frame.
Lower Byte	[7:0]		Lower Byte Contains the data according the command in the Upper Byte of the actual communication frame.

Note: Reading a register needs two SPI frames. In the first frame the RD command is sent. In the second frame the output at SPI signal SO will contain the requested information. A new command can be executed in the second frame.

12.2.3.3 16- and 2x8-bit protocol mixed

The 16-bit and 2x8-bit protocols are mixed according the used commands (see Chapter 12.3.1). Special care should be taken, changing from the 16-bit protocol to the 2x8-bit protocol. In this case, it is important to send a NOP command to S_SI. Otherwise, by sending instead a Command, a collision between the S_SO data in the following frame and the Lower Byte of the 2x8-bit protocol will happen (see Chapter 12.2.3.2).

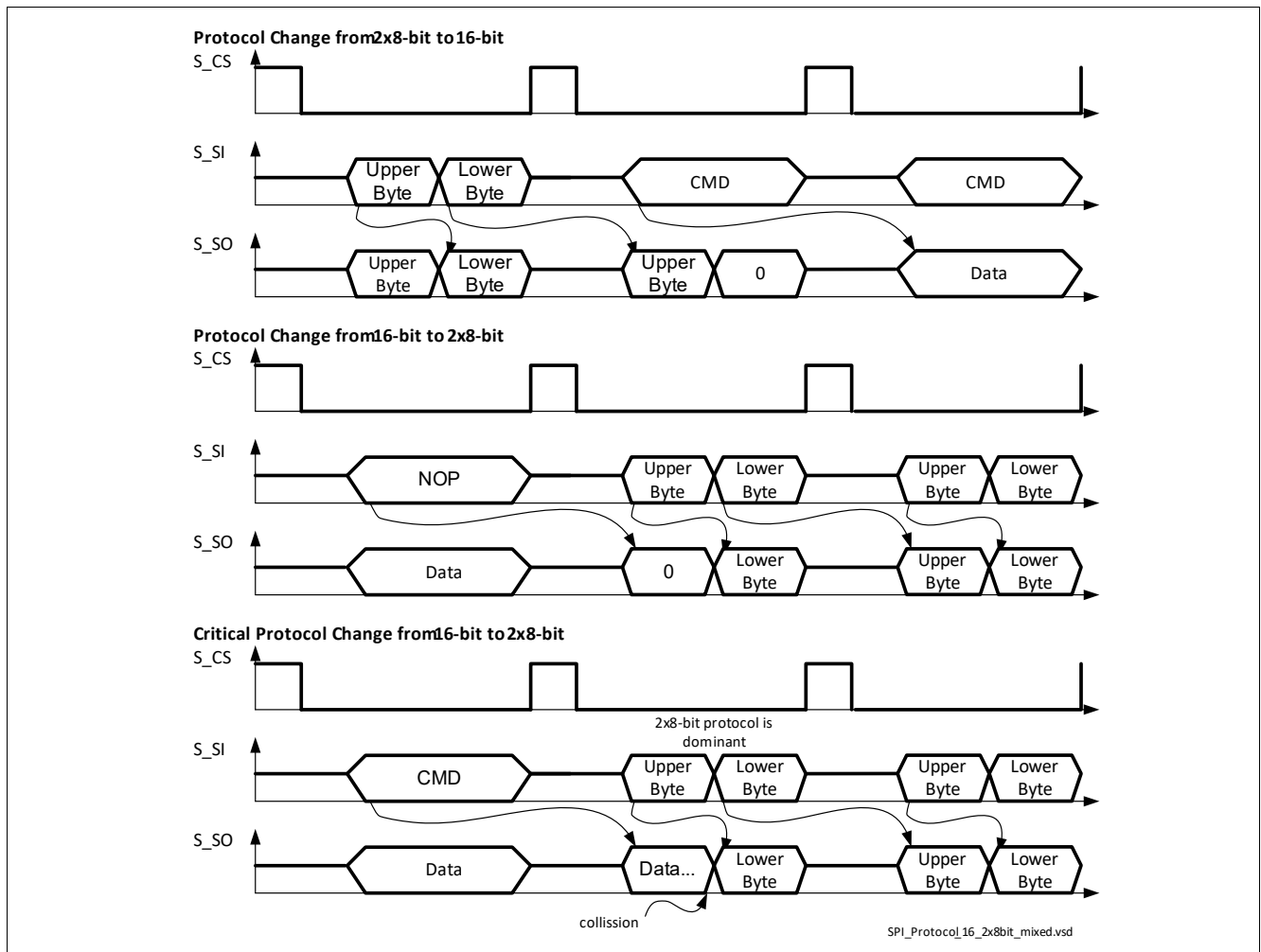

Figure 29 16-bit protocol and 8bit protocol mixed

Control of the device

12.2.3.4 Daisy-Chain and 2x8-bit protocol

when using the TLE8110ED in a daisy-chain connection with other devices (TLE8110ED and non) special care has to be taken to avoid interference of 2x8-bit protocol with normal communication. Few simplified rules must be followed for a safe SPI communication in daisy-chain environment:

1. All TLE8110ED devices have to be routed at the beginning of the chain, other devices than TLE8110ED afterward.
2. compactCONTROL commands (2x8-bit protocol) must not be addressed to TLE8110ED.
3. The SPI frame of the daisy-chain must be extended of additional 8-bit (all zeros 00_H) at beginning of the frame.
4. When a Read/Clear Diagnosis Register A command (DRA, DRACL) is addressed to TLE8110ED, a NOP command must be sent to the next TLE8110ED on the chain.
5. When a Read/Clear Diagonosis Register A command (DRA, DRACL) is addressed to TLE8110ED, response of the next device on the chain must be ignored in the next SPI cycle.

Details in **Figure 30** and **Figure 31**.

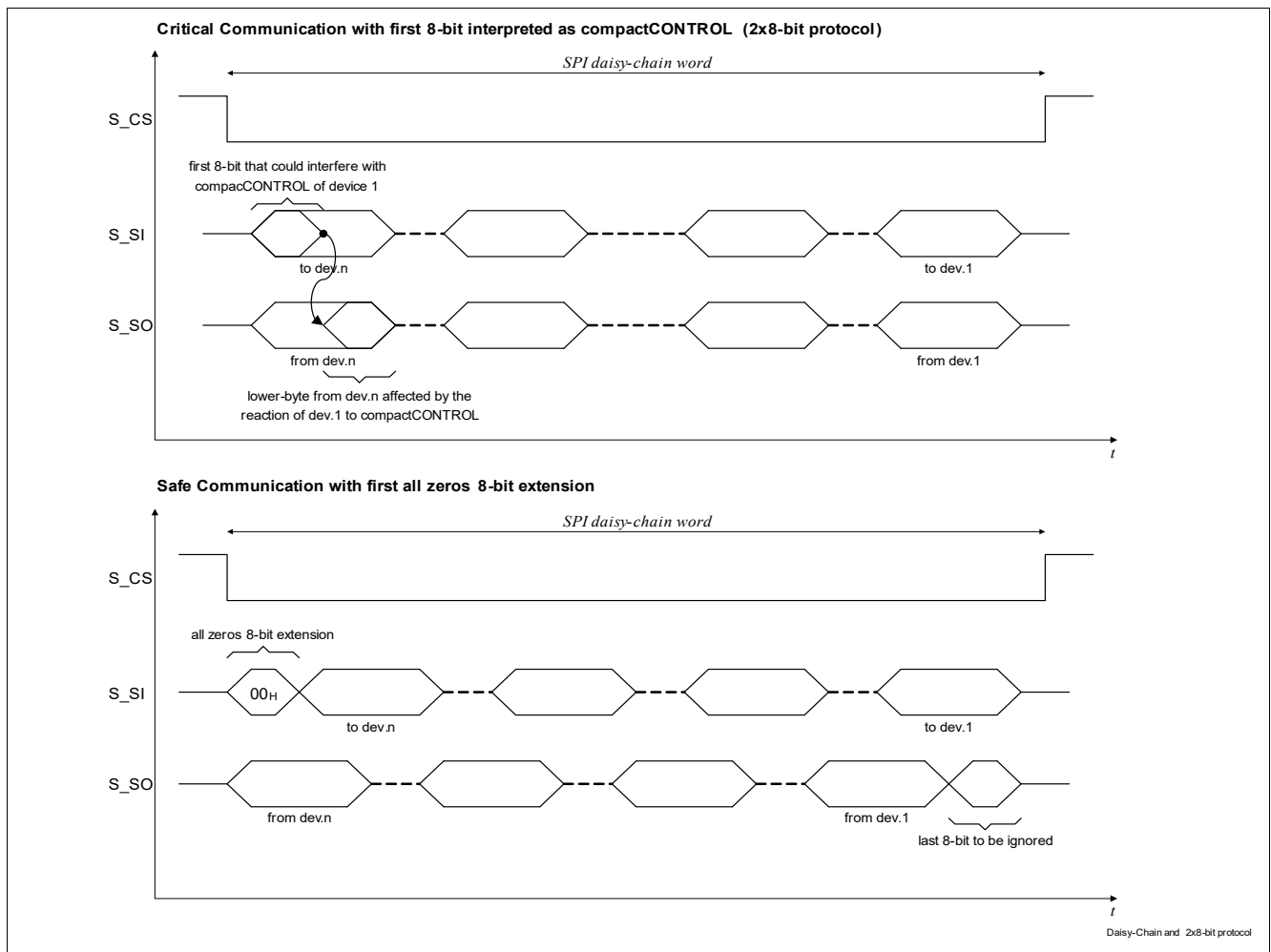

Figure 30 Daisy-Chain and 2x8-bit protocol

Control of the device

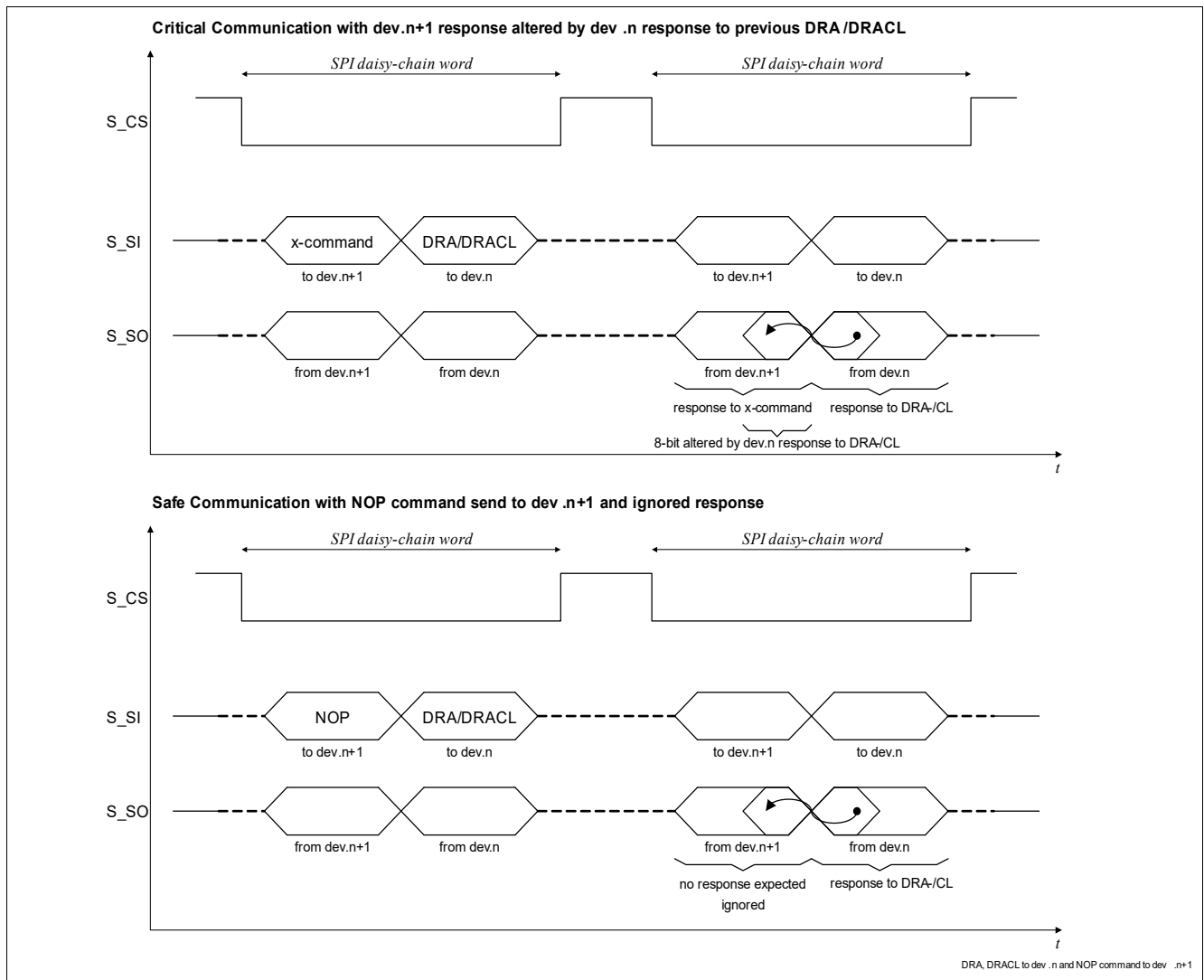

Figure 31 DRA, DRACL to dev.n and NOP command to dev.n+1

12.2.4 safeCOMMUNICATION

The device contains some safety features, which are improving the protection of the application against malfunction in case of disturbance of the communication between the Micro Controller and the Device:

12.2.4.1 Encoding of the commands

The Commands are encoded. In case other bit-patterns, then the defined once are received, the commands are ignored and the communication error can be read out with the command CMD_RS_DS (see Chapter 12.3.1.2).

12.2.4.2 Modulo-8 Counter

The modulo is the integral remainder in integral division. In data communications, a modulo based approach is used to ensure that user information in SPI protocols is in the correct order. The device has a receiver-side counter, and a defined counter size. The modulo counter specifies the number of subsequent numbers available. In case of TLE8110ED Modulo 8 counter specifies 8 serial numbers. The modulo 8 counter ensures that data is taken only, when a multiple of 8 bit has been transferred. If in one transfer cycle not a multiple of

Control of the device

8 bits have been counted, the data frame is ignored and a Communication Error is indicated in the CMD_RSDS - Feedback (see [Chapter 12.3.1.2](#)).

12.3 Register and Command - Overview

This chapter describes the Registers and Commands. The commands allow to carry through some actions, such as reading out or clearing the diagnosis or reading out the Input Pins.

Specially highlighted here should be the encoded CMD_DMSx/OPSx commands - compactCONTROL -, a highly efficient command-set to set a part of the output pins and read out the diagnosis at the same time. Included in this command set is the possibility to check, if the communication works well as also the possibility to read-out some of the parallel Input Pins INx. Using this compact command set can reduce the workload of the micro-controller during run-time significantly.

CMD_RSD is performed and short diagnostics [SD] is returned after each Write Cycle to any of the writable registers.

After start-up of the device, the registers are loaded with the default settings as described below in the register descriptions. The Registers are cleared and set back to the default values, when a low signal is applied to the pin RST or an under-voltage condition appears at the supply pin V_{CC} what causes an under-voltage reset. If a low signal at pin EN is applied or an under-voltage condition appears at pin V_{DD} , the Registers are not cleared.

Table 15 Command Overview

Name	Type	Addr.	Short Description	see:
CMD	W ¹⁾	000 _B	Commands	Chapter 12.3.1
DCC	W ¹⁾	001 _B	Diagnosis Registers and Compact Control	Chapter 12.3.2
OUTx	W/R	010 _B	Output Control Register CHx	Chapter 12.3.3
DEVS	W/R	011 _B	Device Settings	Chapter 12.3.6
MSCS	W/R	100 _B	Reserved	-
ISAx	W/R	101 _B	Input or Serial Mode Register CHx Bank A	Chapter 12.3.4
ISBx	W/R	110 _B	Input or Serial Mode Register CHx Bank B	Chapter 12.3.4
PMx	W/R	111 _B	Parallel Mode Control of CHx with CHy	Chapter 12.3.5

1) if a read command is sent, the command is ignored and S_SO returns a frame with '0'.

Table 16 Register Overview

Name	Addr	11	10	9	8	7	6	5	4	3	2	1	0	def. 1)		
CMD	W ²⁾ 000 _B	0	1	1	1	Command									-	
DCC	W ²⁾ 001 _B	Command														-
OUTx	W/R 010 _B	1	1	OUT 10	OUT 9	OUT 8	OUT 7	OUT 6	OUT 5	OUT 4	OUT 3	OUT 2	OUT 1	C00 _H		
DEVS	W/R 011 _B	RCP	DBT2	DBT1	0	0	0	0	0	0	DCC 10	DCC 9	DCC 18	007 _H		
MSCS	W/R 100 _B	Reserved													000 _H	
ISAx	W/R 101 _B	IS6			IS5		IS4		IS3		IS2		IS1	AAA _H		

Control of the device

Table 16 Register Overview

Name		Addr	11	10	9	8	7	6	5	4	3	2	1	0	def. 1)
ISBx	W/R	110 _B	0	0	0	0	IS10		IS9		IS8		IS6		0AA _H
PMx	W/R	111 _B	0	0	0	0	PM 910	PM 89	PM 78	PM 56	0	PM 34	PM 23	PM 12	000 _H

1) Default values after Reset.

2) if a read command is sent, the command is ignored and S_SO returns a frame with '0'.

Control of the device

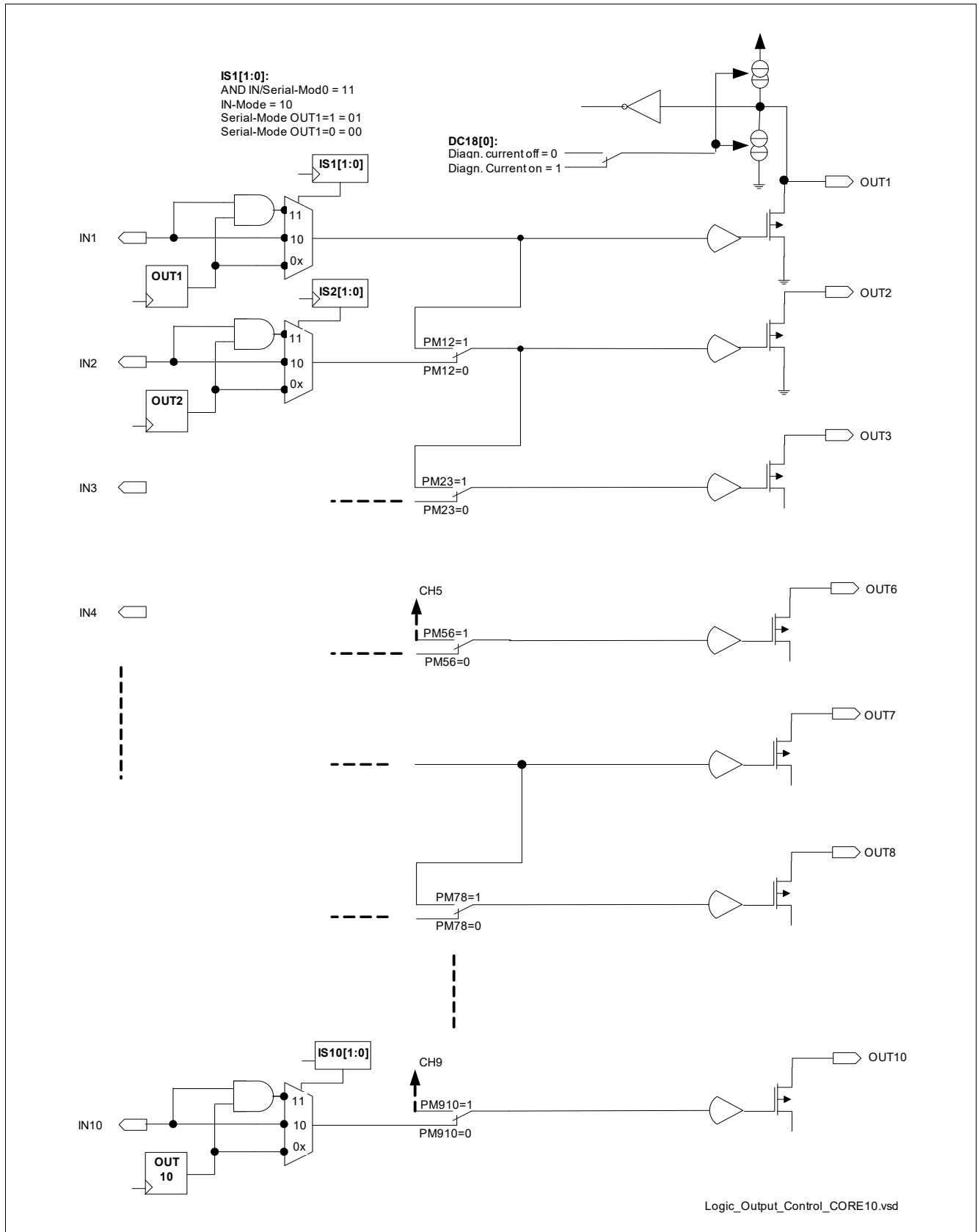

Figure 32 Logic Output Control Block Diagram TLE8110ED

Control of the device

12.3.1 CMD - Commands

By using the Address Range CMD[14:12] = '000' commands can be send to the device. The feedback of the commands is provided in the next SPI SO frame. Details about the Feedback on each command is described in the [Chapter 12.3.1.1](#).

It is possible to perform per each Communication Frame ONE command out of Group-A (see following description of the commands) and ONE command out of Group-B at the same time. Performing more then one Command of one Group is not possible. For the case, this happens, the commands are ignored.

Overview Commands

CMD Command Register

S_SI Serial Input

CMD	11	10	9	8	7	6	5	4	3	2	1	0
RSD	0	1	1	1	0	0	0	0	0	0	0	1
RSDS	0	1	1	1	0	0	0	0	0	0	1	0
RPC	0	1	1	1	0	0	0	0	0	1	0	0
RINx	0	1	1	1	0	0	0	0	1	0	0	0
CSDS	0	1	1	1	0	0	0	1	0	0	0	0
NOP	0	1	1	1	0	0	0	0	0	0	0	0

Command description

Field	Command	Type	Function
-------	---------	------	----------

Command Bits Group-B (Bits [7:4]). All other bit combinations are not valid. Command will be ignored then.

NOP	0000	W	NOP - no operation A frame with 0000 _H will be returned.
CMD_CSDS	0001	W	CMD_CSDS - Command: Clear Short Diagnosis and Device Status Clear the Device Status information. Performing this Clear Command clears the Information in the Reset and Communication Error Information as long as the incident is not present anymore. If the incident is still present, the related Bits remain setted. Performing this command does NOT clear the Diagnosis Registers. The Diagnosis Information is cleared by the Clear Diagnosis Commands (see Chapter 12.3.2). SO returns a Frame with 0000 _H after performing CMD_CSDS or in case this command is carried out together with a command out of Group-A, the feedback is according the Group-A command.

Command Bits Group-A (Bits [3:0]). All other bit combinations are not valid. Command will be ignored then.

CMD_NOP	0000	W	NOP - no operation A frame with 0000 _H will be returned.
CMD_RINx	1000	W	CMD_RINx - Command: Return Input Pin INx -Status See Chapter 12.3.1.4 .
CMD_RPC	0100	W	CMD_PRC - Command: Return Pattern Check See Chapter 12.3.1.3 .

Control of the device

Command description

Field	Command	Type	Function
CMD_RSDS	0010	W	CMD_RSDS - Command: Return Short Diagnosis and Device Status See Chapter 12.3.1.2 .
CMD_RSD	0001	W	CMD_RSD - Command: Return Short Diagnosis See Chapter 12.3.1.1 .

12.3.1.1 CMD_RSD - Command: Return Short Diagnosis

The Command CMD_RSD offers the possibility to read out the OR-operated “short”-Diagnosis within one SO Feedback Frame. The data to be send is latched at the end of the command frame.

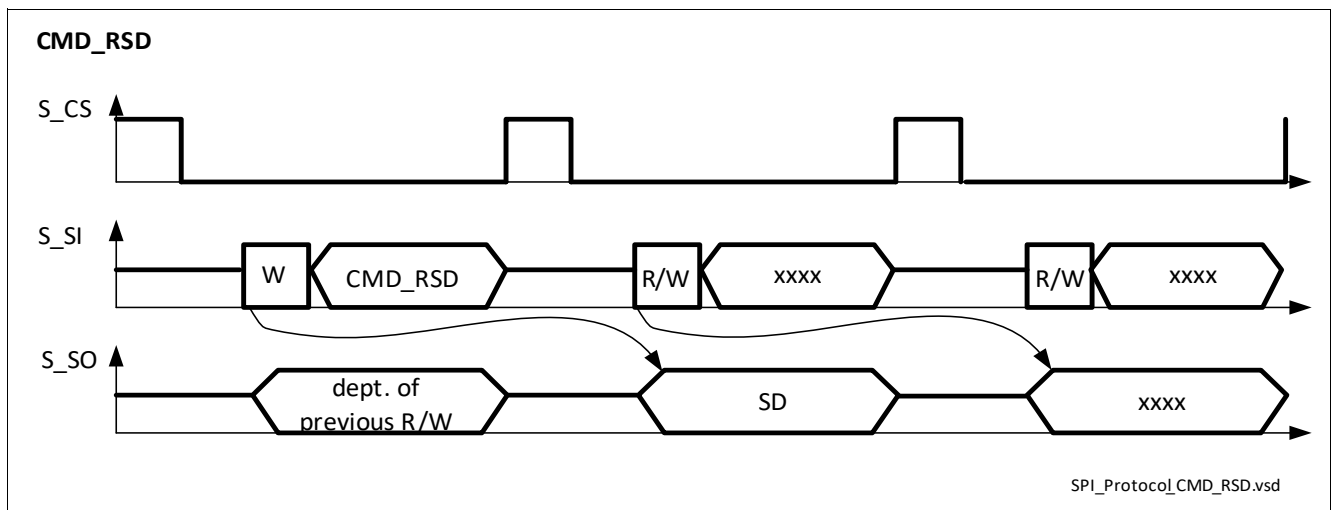

Figure 33 SPI Feedback on CMD_RSD

CMD_RSD

S_SO Serial Output

15	14	13	12	11	10	9	8	7	6	5	4	3	2	1	0
PAR	0	0	0	0	0	SD10	SD9	SD8	SD7	SD6	SD5	SD4	SD3	SD2	SD1

Response description

Field	Bits	Type	Description
-	-	-	SD1-10 Short Diagnosis 0 Normal Operation, 1 Each SD-Bit contains the NAND-operated Diagnosis Error of each related Channel. Details can be read in diagnosis registers. SD is returned after each Write Cycle to any of the writable registers.

Control of the device

12.3.1.2 CMD_RS_DS - Command: Return Short Diagnosis and Device Status

The Command CMD_RS_DS offers the possibility to read out the OR-operated “short”-Diagnosis and the device Status - such as Reset-Information and Communication Error - within one SO Feedback Frame. The data to be send is latched at the end of the command frame.

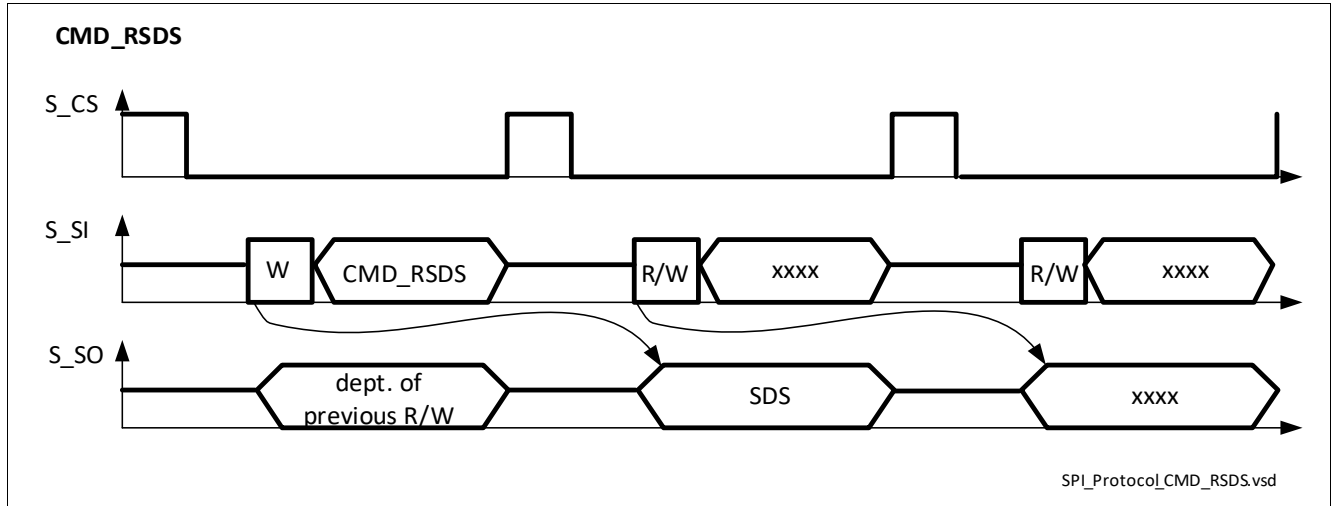

Figure 34 SPI Feedback on CMD_RS_DS

Control of the device

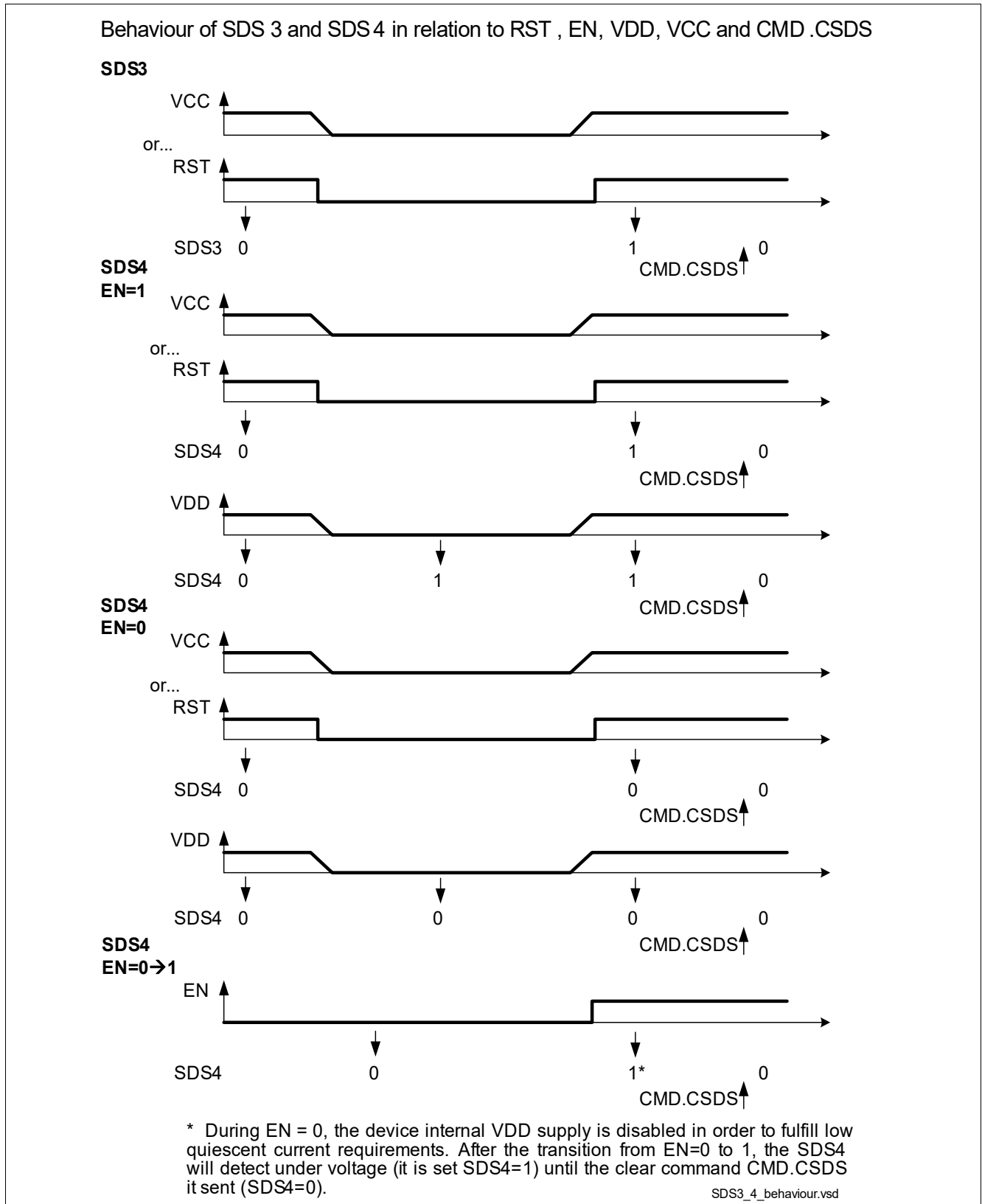

Figure 35 Behaviour of SDS3, 4

Control of the device

CMD_RSDS

S_SO Serial Output

15	14	13	12	11	10	9	8	7	6	5	4	3	2	1	0
PAR	0	0	0	0	0	0	0	SDS8	SDS7	SDS6	SDS5	SDS4	SDS3	SDS2	SDS1

Response description

Field	Bits	Type	Description
-	[7:0]	-	SDS - Short Diagnosis and Device Status
-	0	-	SDS1 - Diagnosis Error in Channel 1 to 6 0 Normal Operation, 1 Diagnosis failure.
-	1	-	SDS2 - Diagnosis Error in Channel 7 to 10 0 Normal Operation, 1 Diagnosis failure.
-	2	-	SDS3 - Under Voltage on VCC (Digital Supply Voltage) See Figure 35 .
-	3	-	SDS4 - Under Voltage on VDD (Analogue Supply Voltage) See Figure 35 .
-	4	-	SDS5 - Modulo Error Counter 0 Normal Operation, 1 Diagnosis failure.
-	5	-	SDS6 - Previous Communication Error - Encoded Command Ignored 0 Normal Operation, 1 Previous Communication Error - Encoded Command ignored.
-	6	-	SDS7 - not used = '0' Always '0'.
-	7	-	SDS7 - not used = '0' Always '0'.

12.3.1.3 CMD_RPC - Command: Return Pattern Check

The Command CMD_RPC offers the possibility to get returned the previous Command to check if the communication works well. The data to be send is latched at the end of the command frame.

Control of the device

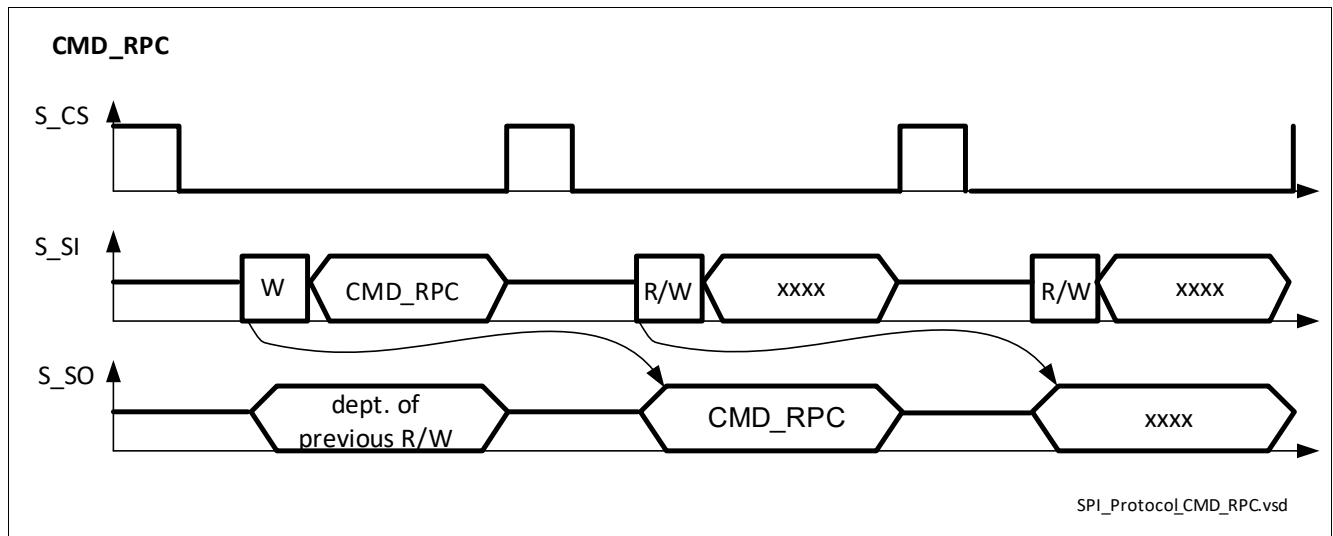

Figure 36 SPI Feedback on CMD_RPC

CMD_RPC

S_SO Serial Output

	15	14	13	12	11	10	9	8	7	6	5	4	3	2	1	0
PAR = 0	0	0	0	0	0	1	1	1	0	0	0	0	0	1	0	0

Response description

Field	Bits	Type	Description
-	-	-	CMD_RPC is returned

12.3.1.4 CMD_RINx - Command: Return Input Pin (INx) - Status

The Command CMD_RINx offers the possibility to read out the actual status of the Input Pins. This command allows to check the correct communication on the INx Pins. The data to be send is latched at the end of the command frame.

Control of the device

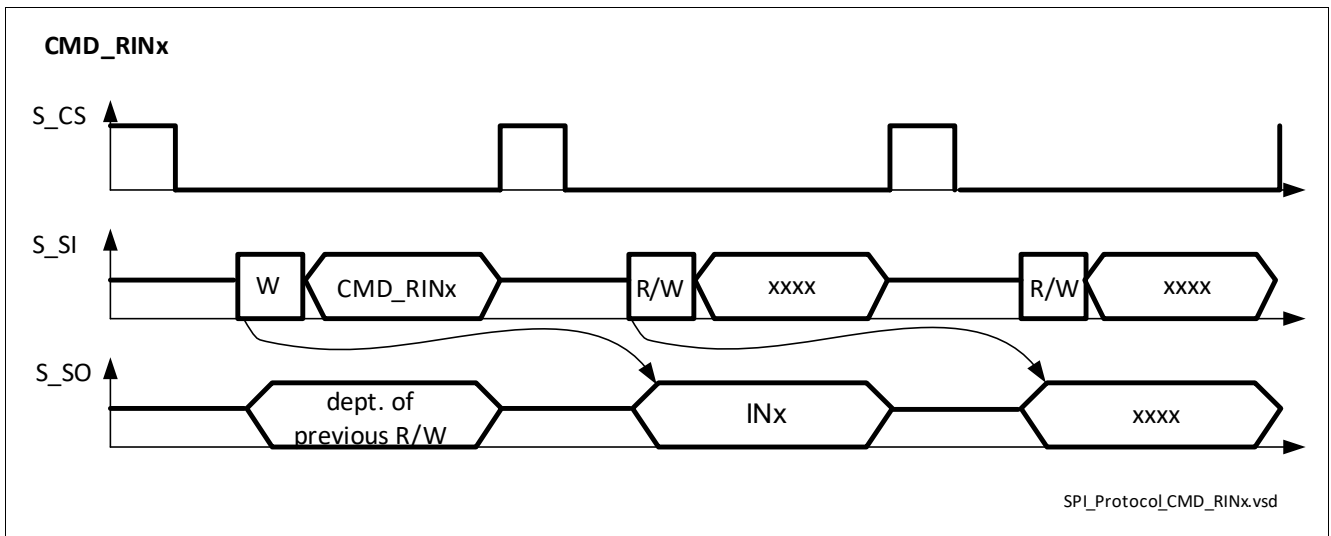

Figure 37 SPI Feedback on CMD_RINx

Control of the device

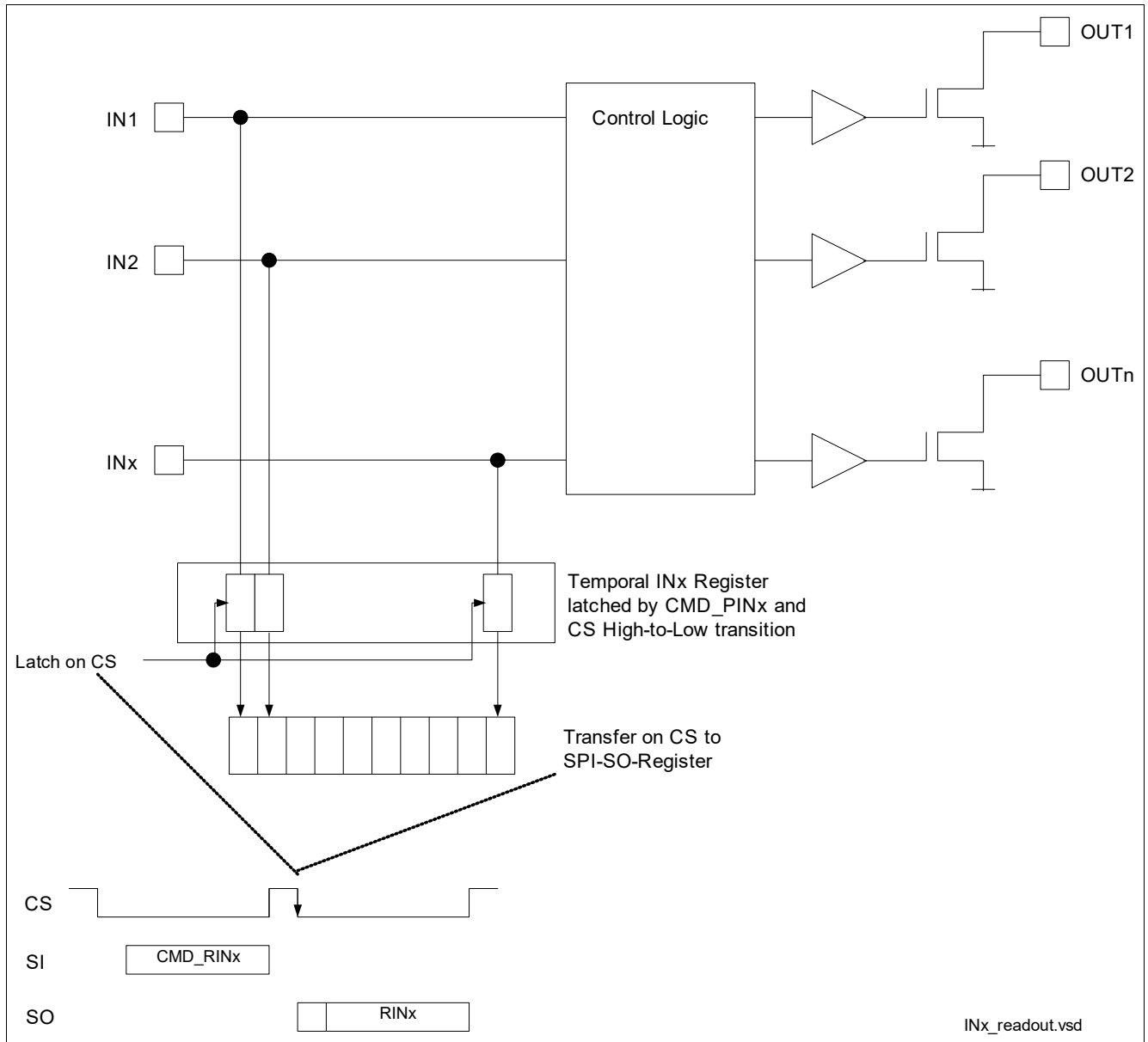

Figure 38 Read-out of INx Pins

CMD_RINx

S_SO Serial Output

15	14	13	12	11	10	9	8	7	6	5	4	3	2	1	0
PAR	0	0	0	0	0	IN10	IN9	IN8	IN7	IN6	IN5	IN4	IN3	IN2	IN1

Control of the device

Response description

Field	Bits	Type	Description
-	-	-	INx Input Pin Status The Status of the INx Pins is read out at the moment of CS High-to-Low transition. Details see Figure 38 . 0 INx = Low corresponding OFF 1 INx = High corresponding ON

12.3.2 DCC - Diagnosis Registers and compactCONTROL

The DCC - Diagnosis and Compact Control Set allows to read out and clear the Diagnosis Registers. Additionally this Command set offers the possibility to proceed with a compactCONTROL Mode using DMS - Diagnosis Mode Set and OPS - Output Pin Set Commands. This compactCONTROL Mode offers the possibility to Control the device with lowest work load on the micro controller side.

If any other pattern then the defined commands is received on S_SI, the command is ignored and rated as a Communication Error. In this case, this incident is reported in SDS ([Chapter 12.3.1.2](#)).

If an Error in the Output Channels is detected by the diagnosis circuit, the result is latched in the diagnosis registers related to each channel.

The Diagnosis Register is not deleted, when it is just read out. The Diagnosis Register byte can only be cleared by using the appropriated command. In this case, the complete Register Bank is cleared.

When issuing a Diagnosis Register Clear command (DRxCL or DMSCL), the idle time t_{Didle} needs to elapse, from the CS low-to-high transition of the clear command, before the register content is effectively cleared ([Figure 39](#)); This time has to be taken into account when trying to read the Diagnosis register content after a clear, see [Chapter 11.3](#) for t_{Didle} definition.

After an overcurrent entry is stored in the diagnosis register (OC), the idle time t_{OCidle} needs to elapse before a clear command can effectively clear the entry; if trying to clear the Diagnosis register after an OCT entry is read ([Figure 39](#)), this time has to be taken into account starting from the CS high-to-low transition of the previous read command, see ([Chapter 11.3](#)) for t_{OCidle} definition.

Control of the device

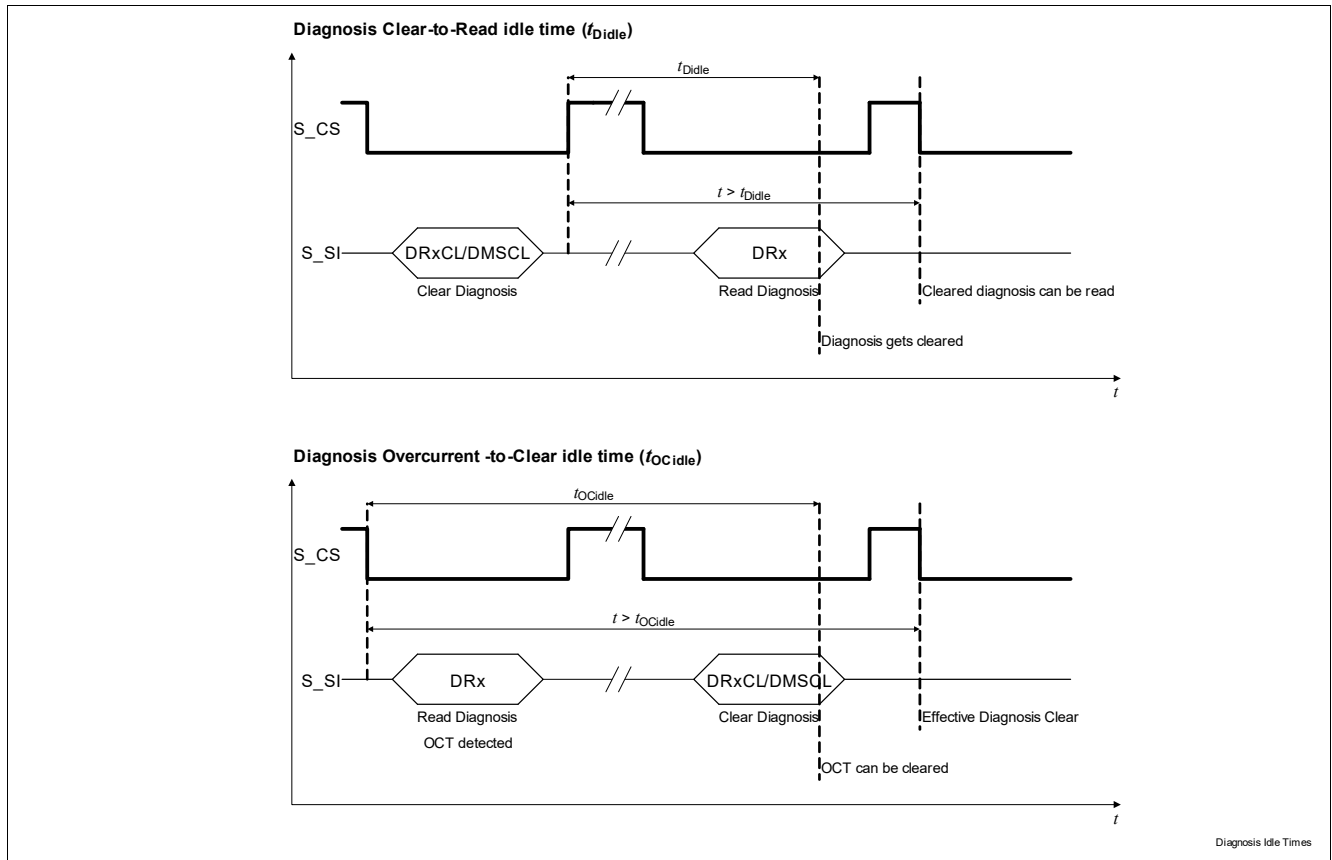

Figure 39 Diagnosis idle times

DCC
Diagnosis Registers and Compact Control

S_SI Serial Input

DCC	11	10	9	8	7	6	5	4	3	2	1	0
DRA	0	1	0	1	0	0	0	0	0	0	0	0
DRB	0	1	1	0	0	0	0	0	0	0	0	0
DRACL	0	0	0	1	0	0	0	0	0	0	0	0
DRBCL	0	0	1	0	0	0	0	0	0	0	0	0
DMSCL/OPSx	1	0	0	0	OPSx							
DMS1/OPSx	1	0	1	1	OPSx							
DMS2/OPSx	1	1	0	1	OPSx							
DMS3/OPSx	1	1	1	0	OPSx							
DMSx/OPS1	1	DMSx			0	0	0	0	0	0	0	1
DMSx/OPS2	1	DMSx			0	0	0	0	0	0	1	0
DMSx/OPS3	1	DMSx			0	0	0	0	0	1	0	0
DMSx/OPS4	1	DMSx			0	0	0	1	0	0	0	0
DMSx/OPS5	1	DMSx			0	0	1	0	0	0	0	0
DMSx/OPS6	1	DMSx			0	1	0	0	0	0	0	0
DMSx/OPS7	1	DMSx			1	0	0	0	0	0	0	0
DMSx/OPS8	1	DMSx			1	0	0	0	0	0	0	0

Control of the device

Command description

Field	Bits	Type	Function
DCC_DRA	[11:0]	W	DRA - Diagnosis Register A (see Chapter 12.3.2.1) Read out Diagnosis Register A. Return the contents in the next SPI frame (see Chapter 12.3.2.2).
DCC_DRB	[11:0]	W	DRB - Diagnosis Register A (see Chapter 12.3.2.1) Read out Diagnosis Register B. Return the contents in the next SPI frame (see Chapter 12.3.2.2).
DCC_DRACL	[11:0]	W	DRACL - Diagnosis Register A Clear Clear the contents of the Diagnosis Register A. Return the content present before the clear in the next SPI Frame. If the Diagnosis Error Remains, the Information remains (see Chapter 12.3.2.2).
DCC_DRBCL	[11:0]	W	DRBCL - Diagnosis Register B Clear Clear the contents of the Diagnosis Register B. Return the content present before the clear in the next SPI Frame. If the Diagnosis Error Remains, the Information remains (see Chapter 12.3.2.2).
DCC_DMSEL	[11:8]	W	DMSEL/OPSx - Diagnosis Mode Set, Clear / Output Pins Set On sending this command, the diagnosis registers DRA, DRB as well as the “virtual” Diagnosis Output Registers DO[7:0] (see Chapter 12.3.2.3) are cleared. Output Pin Settings are done according the content of OPSx. Returns the contents of cleared DR2 on SO in the 2nd byte of the actual communication frame and the Output Pin Feedback in the 1st Byte of the next frame (see Chapter 12.3.2.3).
DCC_DMS1	[11:8]	W	DMS1/OPSx - Diagnosis Mode Set, Register1 / Output Pins Set On sending this command, the diagnosis registers DR1 is selected. Output Pin Settings are done according the content of OPSx. Returns the contents of DR1 on SO in the 2nd byte of the actual communication frame and the Output Pin Feedback in the 1st Byte of the next frame (see Chapter 12.3.2.3).
DCC_DMS2	[11:8]	W	DMS2/OPSx - Diagnosis Mode Set, Register2 / Output Pins Set On sending this command, the diagnosis registers DR2 is selected. Output Pin Settings are done according the content of OPSx. Returns the contents of DR2 on SO in the 2nd byte of the actual communication frame and the Output Pin Feedback in the 1st Byte of the next frame (see Chapter 12.3.2.3).
DCC_DMS3	[11:8]	W	DMS3/OPSx - Diagnosis Mode Set, Register3 / Output Pins Set On sending this command, the diagnosis registers DR3 is selected. Output Pin Settings are done according the content of OPSx. Returns the contents of DR3 on SO in the 2nd byte of the actual communication frame and the Output Pin Feedback in the 1st Byte of the next frame (see Chapter 12.3.2.3).

Control of the device

Command description

Field	Bits	Type	Function
DCC_DMSx/ OPSx	[7:0]	W	<p>DMSx/OPS1 - Diagnosis Mode Set x/ Output Pins Set Command 1</p> <p>On sending this command, the diagnosis register is selected according DMSx. The Output Pins of Channel 7-10 are set according the following definitions. The OPSx are commands, no register. The commands are controlling the contents of ISA, ISB and OUTx.</p> <p>OPS[7:0] - Output Pin Set:</p> <p>0000 0001: CH7 input select, 1: parallel* / 0: Serial 0000 0010: CH8 input select, 1: parallel* / 0: Serial 0000 0100: CH9 input select, 1: parallel* / 0: Serial 0000 1000: CH10 input select, 1: parallel* / 0: Serial 0001 0000: CH7 output set, 1: ON / 0: OFF 0010 0000: CH8 output set, 1: ON / 0: OFF 0100 0000: CH9 output set, 1: ON / 0: OFF 1000 0000: CH10 output set, 1: ON / 0: OFF (*parallel controlled by INx)</p> <p>Sending OR operated combinations of above listed options (only OPSx) are possible in order to control more then one channel at the same time.</p> <p>If parallel mode Mode is selected (in “input select”), the serial settings (in “output select”) are ignored. In parallel Mode, the selected Channels are controlled via INx Pins. The default setting of ISB corresponds the command OPS[7:0] = xxxx 1111b. (parallel mode, status of the Outputs according signal on INx).</p> <p>Returns the contents the selected DRx register on SO in the 2nd byte of the actual communication frame and the Output Pin Feedback [OPF] in the 1st Byte of the next frame (see Chapter 12.3.2.3).</p>

12.3.2.1 DRx - Diagnosis Registers Contents

DRA[1:0]x / DRB[1:0]x

Diagnosis Register CHx Bank A and Bank B

Reset value 0000 0000 0000_B = 000_H

11	10	9	8	7	6	5	4	3	2	1	0
DRA[1]6	DRA[0]6	DRA[1]5	DRA[0]5	DRA[1]4	DRA[0]4	DRA[1]3	DRA[0]3	DRA[1]2	DRA[0]2	DRA[1]1	DRA[0]1

11	10	9	8	7	6	5	4	3	2	1	0
0	0	0	0	DRB[1]10	DRB[0]10	DRB[1]9	DRB[0]9	DRB[1]8	DRB[0]8	DRB[1]7	DRB[0]7

Control of the device

Field	Bits	Type	Function
DRA[1:0]x / DRB[1:0]x	[1:0]	R	<p>DRA[1:0]x / DRB[1:0]x</p> <p>DRn[1]x/DRn[0]x = 11 no Error DRn[1]x/DRn[0]x = 10 Over Load, Shorted Load, Over temperature in ON-Mode DRn[1]x/DRn[0]x = 01 Open Load in OFF-Mode DRn[1]x/DRn[0]x = 00 Short to GND in OFF-Mode default DRx[1:0] = 11B</p> <p>A new error on the same channel will overwrite older information. The diagnosis information which is returned by SO is latched when CS makes a High-to-Low transition of the frame which sends out the register.</p>

12.3.2.2 DRx - Return on DRx Commands

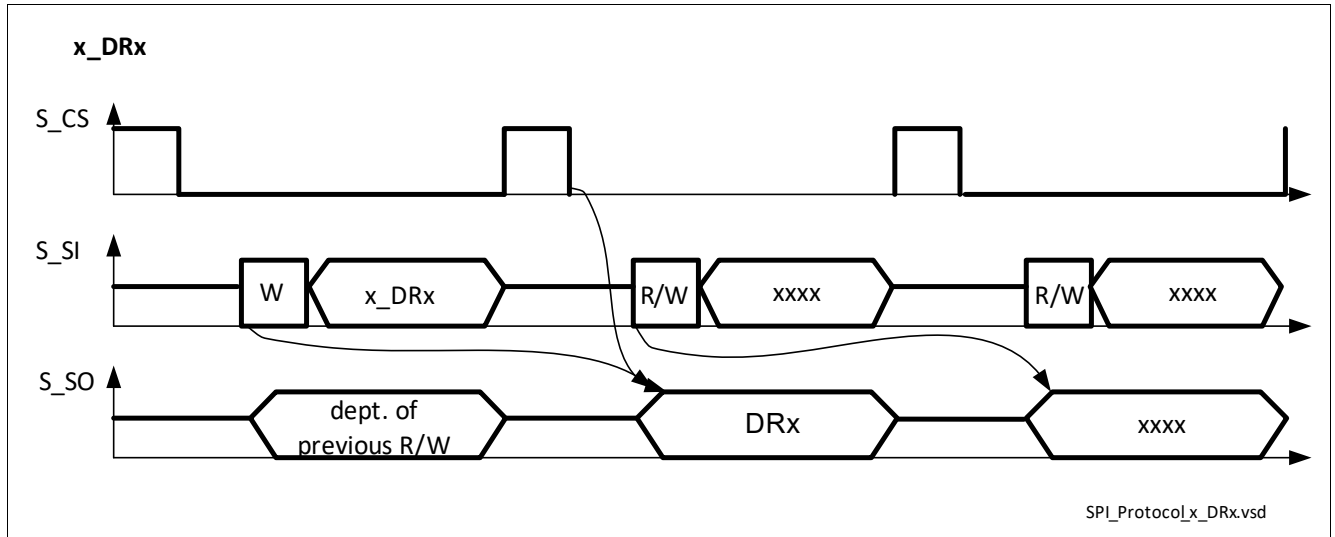

Figure 40 SPI Feedback on x_DRx commands

DRx

Return on DRx Commands

S_SO Serial Output

15	14	13	12	11	10	9	8	7	6	5	4	3	2	1	0
PAR	0	0	1	DRx [1]x	DRx [0]x	DRx [1]x	DRx [0]x	DRx [1]x	DRx [0]x	DRx [1]x	DRx [0]x	DRx [1]x	DRx [0]x	DRx [1]x	DRx [0]x

Response description

Field	Bits	Type	Description
-	-	-	<p>DRx contents</p> <p>0 no diagnosis error 1 diagnosis error</p>

Control of the device

12.3.2.3 DMSx/OPSx - Diagnosis Mode Set / Output Pin Set Commands

Protocol

Each Cycle where a serial data or command frame is sent to the Serial Input [SI] of the SPI interface, a data frame is returned immediately by the Serial Output [SO]. The content of the SO frame is dependent of the previous command which has been sent to SI and the content of the actual content of SI: The first Byte send by S_SI controls the content of the second byte actual returned by S_SO. The second Byte send by S_SI controls the first byte in S_SO of the next frame (see Figure 41).

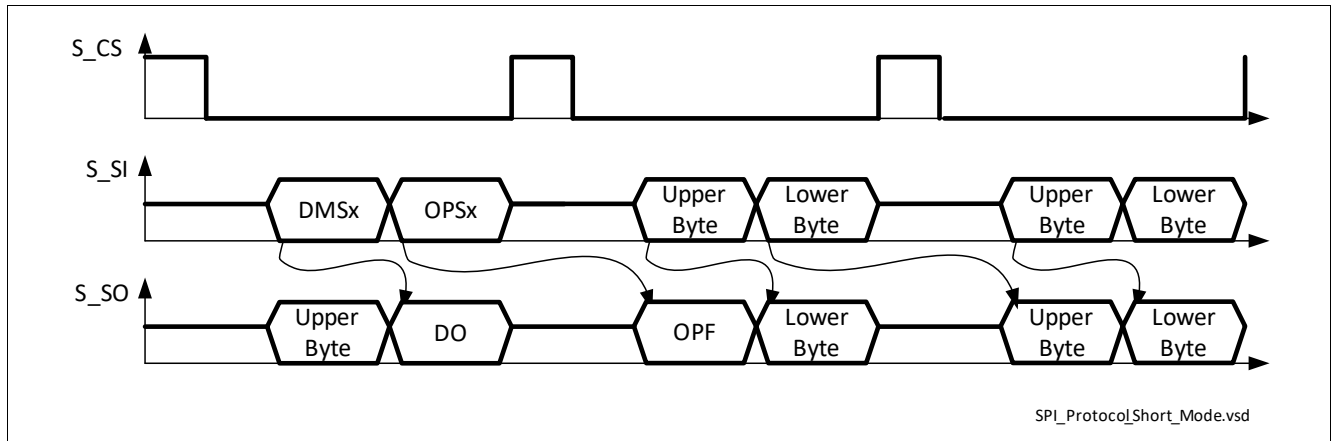

Figure 41 Data Transfer in diagnosis and Compact Control

DMSx/OPSx

Diagnosis Mode Set/ Output Pin Set Commands

S_SI Serial Input

	15	14	13	12	11	10	9	8	7	6	5	4	3	2	1	0
	Diagnosis Mode Set DMS [4:0]								Output Pin Set OPS[7:0]							
	-								Serial mode selected				Parallel or Serial mode			
	0	0	0	1	-	-	-	-	CH10: 1:ON 0:OFF	CH9: 1:ON 0:OFF	CH8: 1:ON 0:OFF	CH7: 1:ON 0:OFF	CH10: 0 = serial 1 = par.	CH9: 0 = serial 1 = par.	CH8: 0 = serial 1 = par.	CH7: 0 = serial 1 = par.

Control of the device

DMSx/OPSx

Diagnosis Mode Set/ Output Pin Set Commands

S_SO Serial Output

15	14	13	12	11	10	9	8	7	6	5	4	3	2	1	0
Output Pin Set Feedback OPF[7:0]								Diagnosis Output DO[7:0]							

Diagnosis Output Registers
DO[7:0]

								7	6	5	4	3	2	1	0
Diag Register-1								DR4[1]	DR4[0]	DR3[1]	DR3[0]	DR2[1]	DR2[0]	DR1[1]	DR1[0]
Diag Register-2								DR1NA	DR3NA	1	1	DR6[1]	DR6[0]	DR5[1]	DR5[0]
Diag Register-3								DR10 [1]	DR10 [0]	DR9[1]	DR9[0]	DR8[1]	DR8[0]	DR7[1]	DR7[0]

Field	Bits	Type	Description
DO[7:0]	[7:0]	R	DO[7:0] - Diagnosis Output Contents according settings of DMS[4:0]. Returned within the same frame as the pointer is send. DRx[1:0] definitions: see Chapter 12.3.2.1 .
DO[7:6]Diag Register-2	[7:6]	R	DO1NA: NAND-operated diagnosis of Diag Register-1 DO3NA: NAND-operated diagnosis of Diag Register-3 0 no diagnosis error is stored in the related Diag Register, 1 at least one diagnosis error is stored in the related Diag Register.

Output Pin Feedback OPF[7:0]

15	14	13	12	11	10	9	8
OPF[7]	OPF[6]	OPF[5]	OPF[4]	OPF[3]	OPF[2]	OPF[1]	OPF[0]

Control of the device

Field	Bits	Type	Description
OPF[7:0]	[15:8]	R	<p>OPF[7:0] - Output Pin Feedback</p> <p>Principally, OPF can return the previously send OPS word and the IN 10:7 -pin settings, dependent serial/ parallel-setting of OPS:</p> <ul style="list-style-type: none"> • If Serial Mode is selected by one or more OPS[3:0]-bits, the related OPF[7:4]-bits are returning the settings of OPS[7:4], send at the previous frame, • if Parallel Mode is selected by one or more OPS[3:0]-bits, the related OPF[7:4]-bits are returning the condition available at the related IN 10:7 Pins at the moment of S_CS high-to-low transition. <p>A mix of both modes is possible and depends on the channel related settings.</p>

Control of the device

12.3.3 OUTx - Output Control Register CHx

The Output Control Register OUTx consists of 10 Bits to control the Output Channel. Each Bit switches ON/OFF the related Channel.

OUTx becomes only active when ISx[1:0] = 0x. For details refer to [Chapter 12.3.4](#).

OUTx DATA

Output Control Register CHx

Reset value 1100 0000 0000 _B = C00 _H											
11	10	9	8	7	6	5	4	3	2	1	0
1	1	OUT10	OUT9	OUT8	OUT7	OUT6	OUT5	OUT4	OUT3	OUT2	OUT1

Field	Bits	Type	Description
OUTx[9:0]	[9:0]	R/W	Data - OUTx[9:0] OUTx = 0 According Channel is switched OFF, OUTx = 1 According Channel is switched ON. Default (all channels OFF) OUT[9:0] = 00 0000 0000 _B = 000 _H .
OUTx[11:10]	[11:10]	R/W	Data - OUTx[11:10] Bits are set to OUT[11:10] = 1.

Control of the device

12.3.4 ISx - INPUT or Serial Mode Control Register, Bank A and Bank B

The INPUT or Serial Control Register [ISx[1:0]] allows to define the way of controlling the Output Channels. There are 4 setting options possible.

1. Standard Serial Control: The related Output Channel is set according the content of the OUTx Register. ([Chapter 12.3.3](#)).
2. A further possibility is the control by the Input Pins.
3. The settings of the Parallel Mode Register PMx[0] (see [Chapter 12.3.5](#)).
4. Additionally possible is the AND operation between the setting of the OUTx register and the PWM signal at the INPUT Pin.

ISAx Command

INPUT or Serial Mode Control Register Bank A

Reset Value: 1010 1010 1010 _B = AAA _H											
11	10	9	8	7	6	5	4	3	2	1	0
IS6		IS5		IS4		IS3		IS2		IS1	

Field	Bits	Type	Description
ISx[1:0]	[11:0]	R/W	Command - ISx[1:0] 0x: Serial Mode - The Channel is set ON/OFF by OUTx, 10: INPUT Mode - CHx ON/OFF according INx, 11: AND operate Mode INx with OUTx -> CHx ON if OUTx & INx = 1, Default all channels ISx[1:0] = 10 _B .

ISBx Command

INPUT or Serial Mode Control Register Bank B

Reset Value: 0000 1010 1010 _B = 0AA _H											
11	10	9	8	7	6	5	4	3	2	1	0
0	0	0	0	IS10		IS9		IS8		IS7	

Field	Bits	Type	Description
ISx[1:0]	[7:0]	R/W	Command - ISx[1:0] 0x: Serial Mode - The Channel is set ON/OFF by OUTx, 10: INPUT Mode - CHx ON/OFF according INx, 11: AND operate Mode INx with OUTx -> CHx ON if OUTx & INx = 1, Default all channels ISx[1:0] = 10 _B .

Control of the device

12.3.5 PMx - Parallel Mode Register CHx

The Parallel Mode Register PMx[1] allows to “inform” the device about externally parallel connected output channels. If a PMx bit is set, the “lower” related Input Channel controls the indicated Output Channels to achieve best possible matching and according to that highest efficiency of both channels. Additionally to that, the CLAMPsafe feature allows high matching during clamping.

PMx Command

Parallel Mode Register CHx; Reset Value: 0000 0000 0000_B = 000_H

11	10	9	8	7	6	5	4	3	2	1	0
0	0	0	0	PM910	PM89	PM78	PM56	0	PM34	PM23	PM12

Field	Bits	Type	Description
PMx	[11:8]	R/W	0
PMx	[7:0]	R/W	<p>PMx - Parallel Mode Bit</p> <p>0 Direct Mode, 1 Parallel Mode of Channel 1 with x+1. Default PMx[0] = 0.</p> <p>Controlling Parallel Mode is possible between Channel 1 to 4, 5 to 6, 7 to 10. In between the groups, no parallel mode is supported but possible.</p> <p>In case Parallel Mode is chosen and a diagnosis error at only one of the channels is detected, the according diagnosis bit is set. This information mismatch can be caused by tolerance related inbalance of the channels connected together in parallel mode. The diagnosis bits should be or-operated by the Micro Controller side.</p>

Control of the device

12.3.6 DEVS - Device Settings

The Register allows additional Device settings. For details refer also to the Chapter “Electrical Characteristics”. The Diagnosis Current Control register allow to select between different Diagnosis Modes. The Diagnosis Currents can be switched off to avoid glowing of any connected LEDs.

DEVS Command

Device Settings

Reset Value: 0000 0000 0111_B = 007_H

11	10	9	8	7	6	5	4	3	2	1	0
RCP	DBT2	DBT1	0	0	0	0	0	0	DCC10	DCC9	DCC18

Field	Bits	Type	Description
RCP	11	R/W	RCP - Reverse Current Protection 0 disabled, 1 reverse current comp is enabled (valid for all Channels). Default RPC = 0.
DBT[2:1]	[10:9]	R/W	DBT2,1 - Diagnosis Blind Time Channel 7 to 10 0,0 standard Filter Time of typ. 150µs, 1,0 standard Filter Time of typ. 150µs, 0,1 OFF-state diagnosis Blind Time of typ. 2.5ms, 1,1 OFF-state diagnosis Blind Time of typ. 5ms.
DEVS[7:5]	[7:5]	R/W	not used. Set to 0.
DEVS[4:3]	[4:3]	R/W	0
DCCx	[2:0]	R/W	DCCx - Diagnosis Current Control DCC18 switching ON/OFF diagnosis current of CH1-8, DCC9 switching ON/OFF diagnosis current of CH9, DCC10 switching ON/OFF diagnosis current of CH10. 0 OFF-State Diagnosis (Detection of open load and short to GND) of CHx is switched OFF. ON state diagnosis (over current and over temperature detection) is still active. Diagnosis Current is switched OFF. 1 OFF-State (Detection of open load and short to GND) and ONState (over current and over temperature detection) Diagnosis of CHx switched ON, Diagnosis Current is switched ON. Default DCC = 1.

Package Outlines

13 Package Outlines

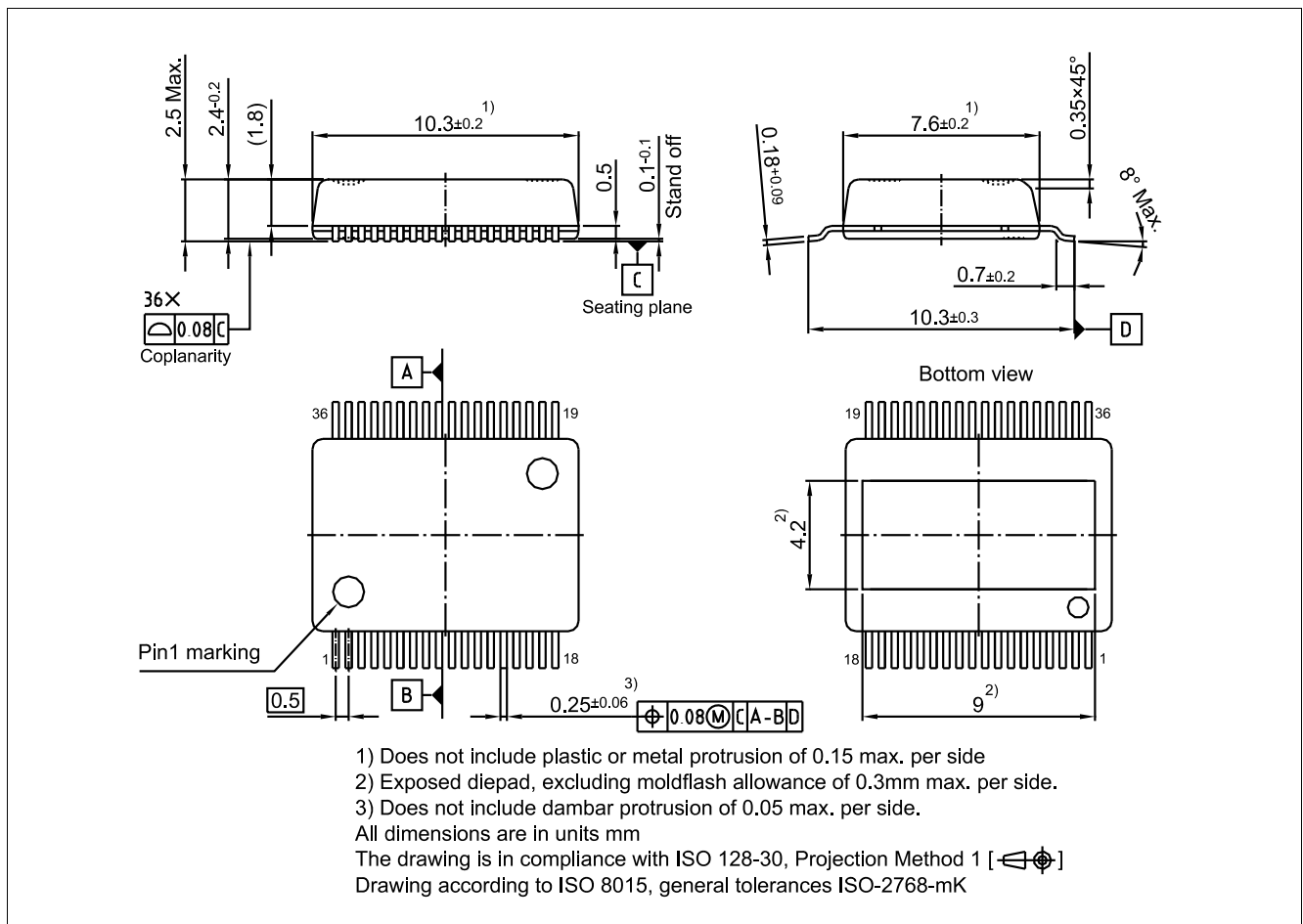

Figure 42 PG-DSO-36-72 Exposed Pad

Green Product (RoHS compliant)

To meet the world-wide customer requirements for environmentally friendly products and to be compliant with government regulations the device is available as a Green Product. Green Products are RoHS compliant (i.e Pb-free finish on leads and suitable for Pb-free soldering according to IPC/JEDEC J-STD-020).

Floating Expose pad

The expose pad of TLE8110ED is floated. It is highly recommended to connect the expose pad to GND pins externally.

For further information on alternative packages, please visit our website:

<http://www.infineon.com/packages>.

Dimensions in mm

Revision History

14 Revision History

Table 17 Revision History

TLE8110ED

Revision History: 2021-04-30 , Rev. 1.1

Rev. 1.1	<ul style="list-style-type: none"> • P_4.3.2: Parameter Junction to ambient added • P_8.2.2/P_8.2.6: Diagnosis current units updated (mA to μA) • Chapter 13, Package Outlines: Figure 42 updated
Rev. 1.0	Final Datasheet

Trademarks

All referenced product or service names and trademarks are the property of their respective owners.

Edition 2021-04-30

Published by

Infineon Technologies AG

81726 Munich, Germany

© 2021 Infineon Technologies AG.

All Rights Reserved.

Do you have a question about any aspect of this document?

Email: erratum@infineon.com

Document reference

Z8F56166608

IMPORTANT NOTICE

The information given in this document shall in no event be regarded as a guarantee of conditions or characteristics ("Beschaffenhheitsgarantie").

With respect to any examples, hints or any typical values stated herein and/or any information regarding the application of the product, Infineon Technologies hereby disclaims any and all warranties and liabilities of any kind, including without limitation warranties of non-infringement of intellectual property rights of any third party.

In addition, any information given in this document is subject to customer's compliance with its obligations stated in this document and any applicable legal requirements, norms and standards concerning customer's products and any use of the product of Infineon Technologies in customer's applications.

The data contained in this document is exclusively intended for technically trained staff. It is the responsibility of customer's technical departments to evaluate the suitability of the product for the intended application and the completeness of the product information given in this document with respect to such application.

For further information on technology, delivery terms and conditions and prices, please contact the nearest Infineon Technologies Office (www.infineon.com).

WARNINGS

Due to technical requirements products may contain dangerous substances. For information on the types in question please contact your nearest Infineon Technologies office.

Except as otherwise explicitly approved by Infineon Technologies in a written document signed by authorized representatives of Infineon Technologies, Infineon Technologies' products may not be used in any applications where a failure of the product or any consequences of the use thereof can reasonably be expected to result in personal injury.

X-ON Electronics

Largest Supplier of Electrical and Electronic Components

Click to view similar products for [Power Switch ICs - Power Distribution category](#):

Click to view products by [Infineon manufacturer](#):

Other Similar products are found below :

[TCK111G,LF\(S\)](#) [FPF1018](#) [DS1222](#) [TCK2065G,LF](#) [SZNCP3712ASNT3G](#) [MIC2033-05BYMT-T5](#) [MIC2033-12AYMT-T5](#) [MIC2033-05BYM6-T5](#) [SLG5NT1437VTR](#) [SZNCP3712ASNT1G](#) [DML1008LDS-7](#) [KTS1670EDA-TR](#) [KTS1640QGDV-TR](#) [KTS1641QGDV-TR](#) [U6513A](#) [MIC2012YM-TR](#) [MP5095GJ-P](#) [TPS2021IDRQ1](#) [TPS2104DBVR](#) [TPS22958NDGKR](#) [MIC2098-1YMT-TR](#) [MIC94062YMT TR](#) [MIC2015-1.2YM6 TR](#) [MIC2075-2YM](#) [MIC94068YML-TR](#) [SIP32461DB-T2-GE1](#) [NCP335FCT2G](#) [FPF1504UCX](#) [TCK105G,LF\(S\)](#) [AP2411S-13](#) [AP2151DSG-13](#) [AP2172MPG-13](#) [MIC94094YC6-TR](#) [MIC94093YC6-TR](#) [MIC94064YC6-TR](#) [MIC94061YMT-TR](#) [MIC2505-1YM](#) [MIC94085YFT-TR](#) [MIC94042YFL-TR](#) [MIC2005-1.2YM6-TR](#) [SIP32510DT-T1-GE3](#) [NCP333FCT2G](#) [BTS3050TFATMA1](#) [NCP331SNT1G](#) [TPS2092DR](#) [TPS2063DR](#) [MIC2008YML-TR](#) [MIC94084YFT-TR](#) [MIC2040-1YMM](#) [DIO1280WL12](#)