

TLE8250SJ

High speed CAN transceiver



RoHS



Features

- Compliant to ISO 11898-2:2016
- Wide common mode range for electromagnetic immunity (EMI)
- Very low electromagnetic emission (EME)
- Excellent ESD robustness
- Guaranteed and improved loop delay symmetry to support CAN FD data frames up to 2 MBit/s
- Extended supply range on V_{CC} supply
- CAN short circuit proof to ground, battery and V_{CC}
- TxD time-out function
- Low CAN bus leakage current in power-down state
- Overtemperature protection
- Protected against automotive transients
- Receive-only mode and power-save mode
- Green Product (RoHS compliant)
- Certified according to latest VeLIO (Vehicle LAN Interoperability & Optimization) test requirements for the Japanese market

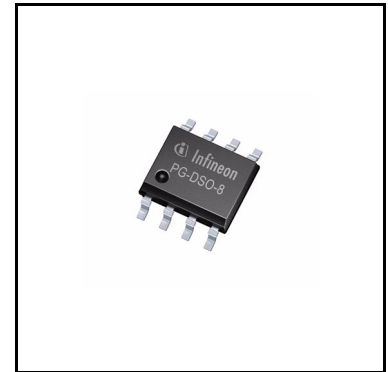

Potential applications

- Engine control unit (ECUs)
- Transmission control units (TCUs)
- Chassis control modules
- Electric power steering

Product validation

Qualified for automotive applications. Product validation according to AEC-Q100.

Description

The TLE8250SJ is a transceiver designed for HS CAN networks in automotive and industrial applications. As an interface between the physical bus layer and the CAN protocol controller, the TLE8250SJ drives the signals to the bus and protects the microcontroller against interferences generated within the network. Based on the high symmetry of the CANH and CANL signals, the TLE8250SJ provides a very low level of electromagnetic emission (EME) within a wide frequency range.

The TLE8250SJ fulfills or exceeds the requirements of the ISO 11898-2:2016.

The TLE8250SJ provides a receive-only mode and a power-save mode. It is designed to fulfill the enhanced physical layer requirements for CAN FD and supports data rates up to 2 MBit/s.

On the basis of a very low leakage current on the HS CAN bus interface the TLE8250SJ provides an excellent passive behavior in power-down state. These and other features make the TLE8250SJ exceptionally suitable for mixed supply HS CAN networks.

Based on the Infineon Smart Power Technology SPT, the TLE8250SJ provides excellent ESD immunity together with a very high electromagnetic immunity (EMI). The TLE8250SJ and the Infineon SPT technology are AEC qualified and tailored to withstand the harsh conditions of the automotive environment.

Three different operating modes, additional fail-safe features like a TxD time-out and the optimized output slew rates on the CANH and CANL signals, make the TLE8250SJ the ideal choice for large HS CAN networks with high data transmission rates.

Type	Package	Marking
TLE8250SJ	PG-DSO-8	8250

Table of contents

1	Block diagram	4
2	Pin configuration	5
2.1	Pin assignment	5
2.2	Pin definitions	5
3	Functional description	6
3.1	High speed CAN physical layer	6
3.2	Modes of operation	8
3.2.1	Normal-operating mode	8
3.2.2	Power-save mode	8
3.2.3	Receive-only mode	8
3.3	Power-up and undervoltage condition	9
3.3.1	Power-down state	10
3.3.2	Power-up	10
3.3.3	Undervoltage on the transmitter supply V_{CC}	11
4	Fail safe functions	12
4.1	Short circuit protection	12
4.2	Unconnected logic pins	12
4.3	TxD time-out function	12
4.4	Overtemperature protection	13
4.5	Delay time for mode change	13
5	General product characteristics	14
5.1	Absolute maximum ratings	14
5.2	Functional range	15
5.3	Thermal resistance	15
6	Electrical characteristics	16
6.1	Functional device characteristics	16
6.2	Diagrams	21
7	Application information	23
7.1	ESD robustness according to IEC61000-4-2	23
7.2	Application example	24
7.3	Examples for mode changes	25
7.3.1	Mode change while the TxD signal is “low”	26
7.3.2	Mode change while the bus signal is dominant	26
7.4	Further application information	28
8	Package information	29
9	Revision history	30

Block diagram

1 Block diagram

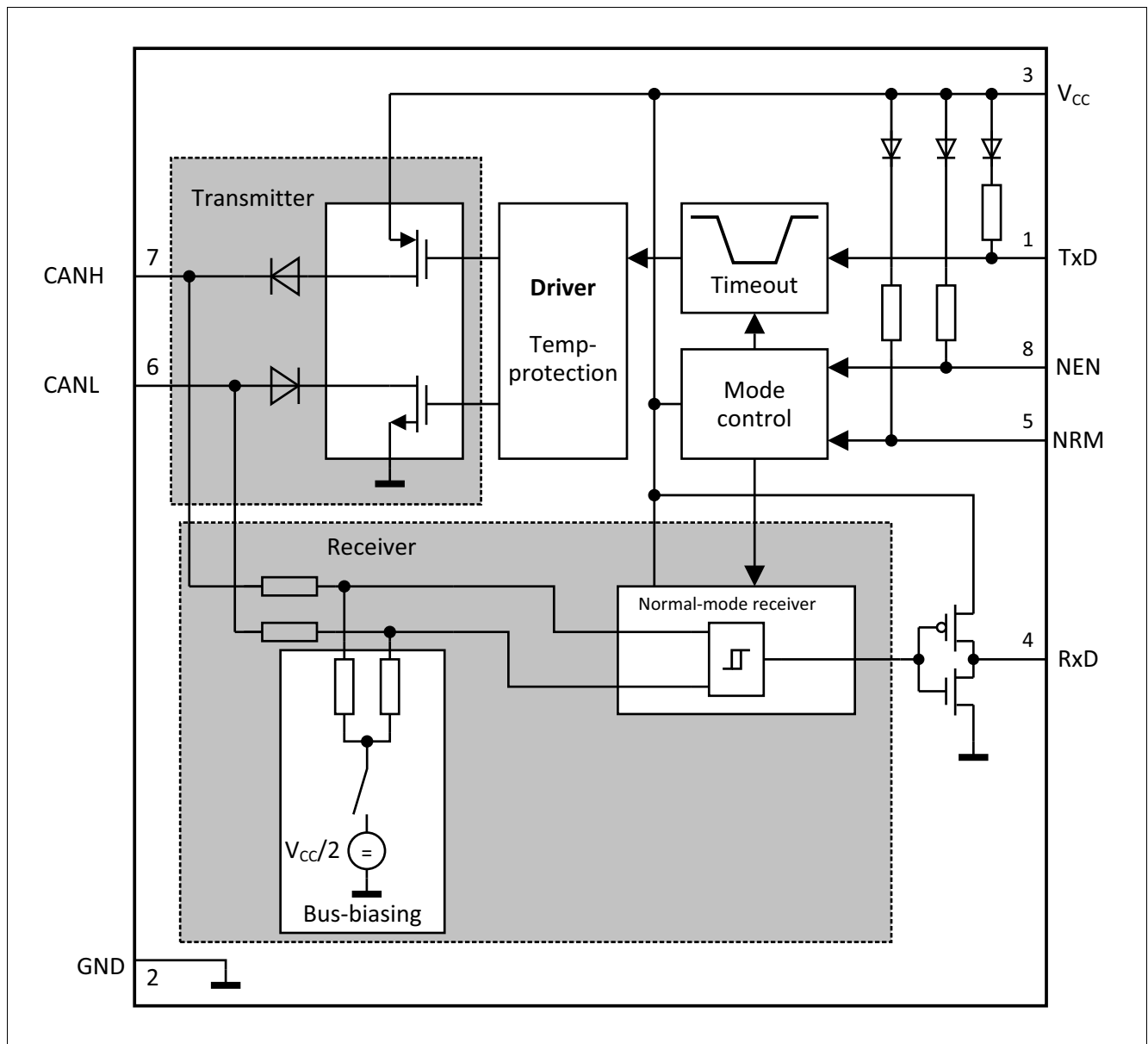

Figure 1 Functional block diagram

Pin configuration

2 Pin configuration

2.1 Pin assignment

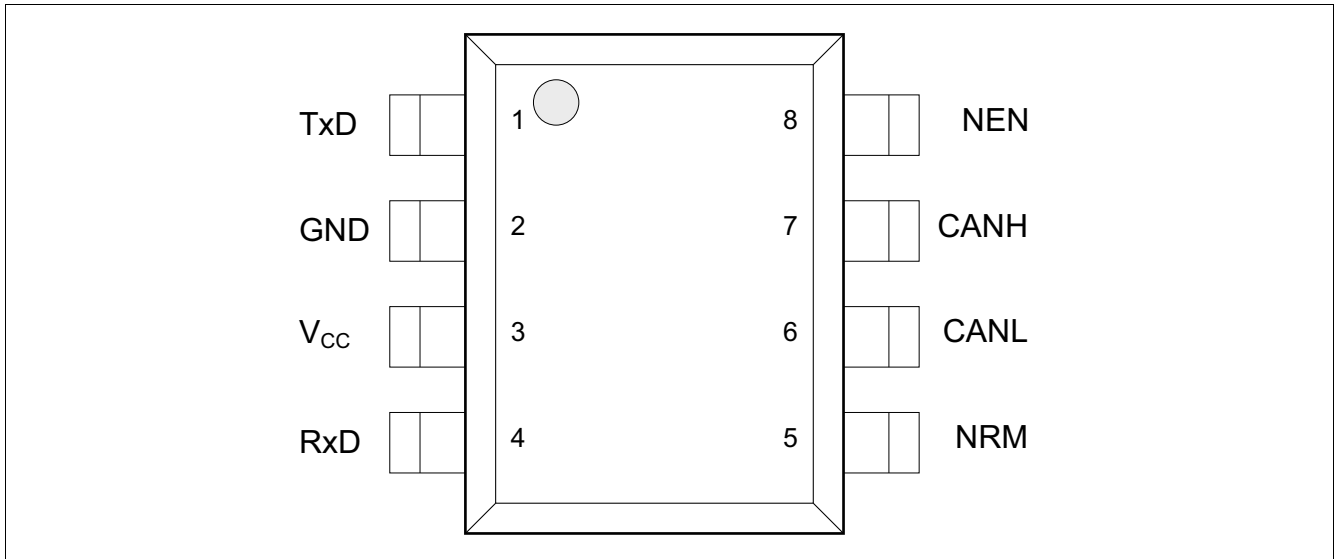

Figure 2 Pin configuration

2.2 Pin definitions

Table 1 Pin definitions and functions

Pin No.	Symbol	Function
1	TxD	Transmit data input; internal pull-up to V_{CC} , “low” for dominant state.
2	GND	Ground
3	V_{CC}	Transmitter supply voltage; 100 nF decoupling capacitor to GND required.
4	RxD	Receive data output; “low” in dominant state.
5	NRM	Not receive-only mode input; control input for selecting receive-only mode, internal pull-up to V_{CC} , “low” for receive-only mode.
6	CANL	CAN bus low level I/O; “low” in dominant state.
7	CANH	CAN bus high level I/O; “high” in dominant state.
8	NEN	Not enable input; internal pull-up to V_{CC} , “low” for normal-operating mode or receive-only mode.

Functional description

3 Functional description

HS CAN is a serial bus system that connects microcontrollers, sensors and actuators for real-time control applications. The use of the Controller Area Network (abbreviated CAN) within road vehicles is described by the international standard ISO 11898. According to the 7-layer OSI reference model the physical layer of a HS CAN bus system specifies the data transmission from one CAN node to all other available CAN nodes within the network. The physical layer specification of a CAN bus system includes all electrical and mechanical specifications of a CAN network. The CAN transceiver is part of the physical layer specification. Several different physical layer standards of CAN networks have been developed in recent years. The TLE8250SJ is a high speed CAN transceiver without a wake-up function and defined by the international standard ISO 11898-2:2016.

3.1 High speed CAN physical layer

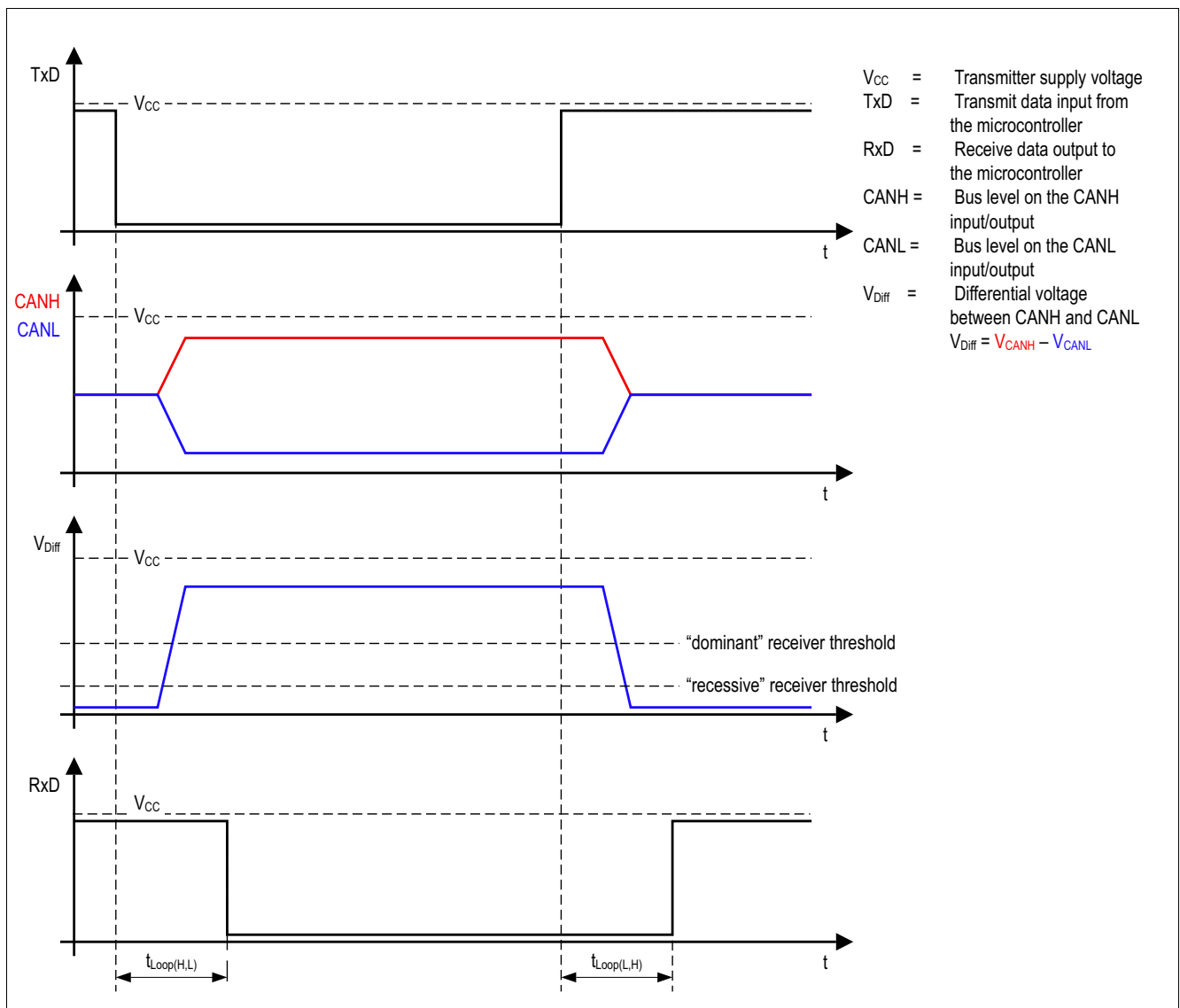

Figure 3 High speed CAN bus signals and logic signals

Functional description

The TLE8250SJ is a high speed CAN transceiver, operating as an interface between the CAN controller and the physical bus medium. A HS CAN network is a two wire, differential network which allows data transmission rates for CAN FD frames up to 2 MBit/s. Characteristic for HS CAN networks are the two signal states on the HS CAN bus: dominant and recessive (see [Figure 3](#)).

V_{CC} and GND are the supply pins for the TLE8250SJ. The pins CANH and CANL are the interface to the HS CAN bus and operate in both directions, as an input and as an output. RxD and TxD pins are the interface to the CAN controller, the TxD pin is an input pin and the RxD pin is an output pin. The NEN and NRM pins are the input pins for the mode selection (see [Figure 4](#)).

By setting the TxD input pin to logical “low” the transmitter of the TLE8250SJ drives a dominant signal to the CANH and CANL pins. Setting TxD input to logical “high” turns off the transmitter and the output voltage on CANH and CANL discharges towards the recessive level. The recessive output voltage is provided by the bus-biasing (see [Figure 1](#)). The output of the transmitter is considered to be dominant, when the voltage difference between CANH and CANL is at least higher than 1.5 V ($V_{Diff} = V_{CANH} - V_{CANL}$).

Parallel to the transmitter the normal-mode receiver monitors the signal on the CANH and CANL pins and indicates it on the RxD output pin. A dominant signal on the CANH and CANL pins sets the RxD output pin to logical “low”, vice versa a recessive signal sets the RxD output to logical “high”. The normal-mode receiver considers a voltage difference (V_{Diff}) between CANH and CANL above 0.9 V as dominant and below 0.5 V as recessive.

To be conform with HS CAN features, like the bit to bit arbitration, the signal on the RxD output has to follow the signal on the TxD input within a defined loop delay $t_{Loop} \leq 255$ ns.

Functional description

3.2 Modes of operation

The TLE8250SJ supports three different modes of operation, power-save mode, receive-only mode and normal-operating mode while the transceiver is supplied according to the specified functional range. The mode of operation is selected by the NEN and the NRM input pins (see [Figure 4](#)).

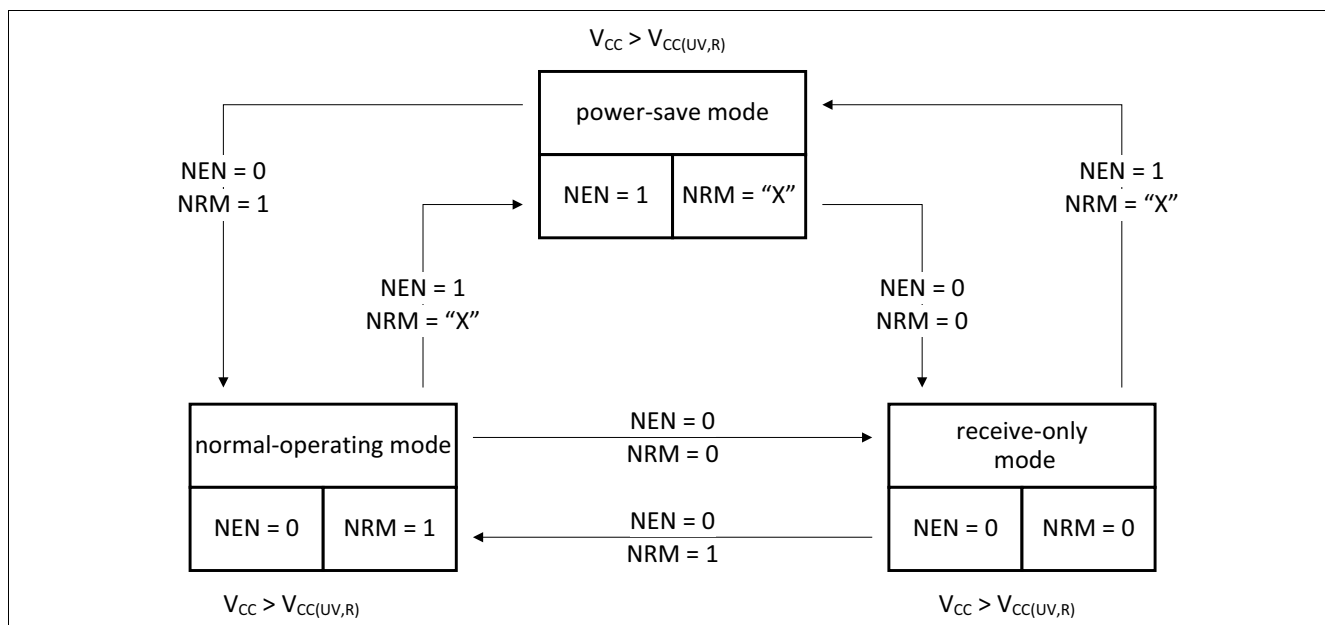

Figure 4 Mode state diagram

3.2.1 Normal-operating mode

In normal-operating mode the transmitter and the receiver of the HS CAN transceiver TLE8250SJ are active (see [Figure 1](#)). The HS CAN transceiver sends the serial data stream on the TxD input pin to the CAN bus. The data on the CAN bus is displayed at the RxD pin simultaneously. A logical "low" signal on the NEN pin and a logical "high" signal on the NRM pin selects the normal-operating mode, while the transceiver is supplied by V_{CC} (see [Table 2](#) for details).

3.2.2 Power-save mode

The power-save mode is an idle mode of the TLE8250SJ with optimized power consumption. In power-save mode the transmitter and the normal-mode receiver are turned off. The TLE8250SJ can not send any data to the HS CAN bus nor receive any data from the HS CAN bus.

The RxD output pin is permanently "high" in the power-save mode.

A logical "high" signal on the NEN pin selects the power-save mode, while the transceiver is supplied by the transmitter supply V_{CC} (see [Table 2](#) for details).

In power-save mode the bus input pins are not biased. Therefore the CANH and CANL input pins are floating and the HS CAN bus interface has a high resistance.

3.2.3 Receive-only mode

In receive-only mode the normal-mode receiver is active and the transmitter is turned off. The TLE8250SJ can receive data from the HS CAN bus, but cannot send any data to the HS CAN bus.

A logical "low" signal on the NEN pin and a logical "low" signal on the NRM pin selects the receive-only mode, while the transceiver is supplied by V_{CC} (see [Table 2](#) for details).

Functional description

3.3 Power-up and undervoltage condition

By detecting an undervoltage event or by switching off the transmitter power supply V_{CC} , the transceiver TLE8250SJ changes the mode of operation (details see Figure 5).

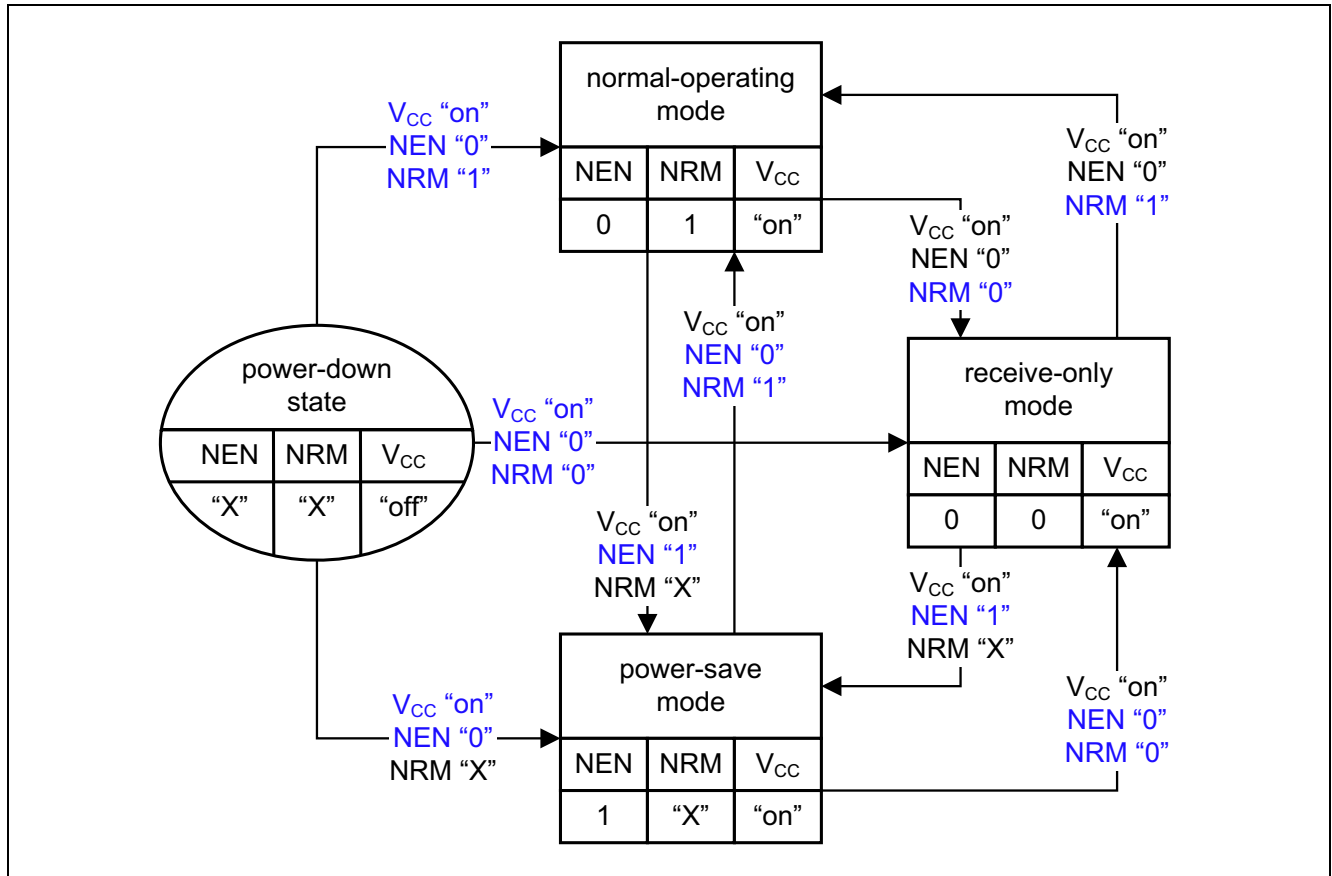

Figure 5 Power-up and undervoltage

Table 2 Modes of operation

Mode	NEN	NRM	V_{CC}	Bus-bias	Transmitter	Normal-mode receiver	Low-power receiver
Normal-operating	"low"	"high"	"on"	$V_{CC}/2$	"on"	"on"	not available
Power-save	"high"	"X"	"on"	floating	"off"	"off"	not available
Receive-only	"low"	"low"	"on"	$V_{CC}/2$	"off"	"on"	not available
Power-down state	"X ¹⁾ "	"X"	"off"	floating	"off"	"off"	not available

1) "X": Don't care.

Functional description

3.3.1 Power-down state

Independent of the NEN and NRM input pins the TLE8250SJ is in power-down state when the transmitter supply voltage V_{CC} is turned off (see [Figure 5](#)).

In the power-down state the input resistors of the receiver are disconnected from the bus biasing $V_{CC}/2$. The CANH and CANL bus interface of the TLE8250SJ is floating and acts as a high-impedance input with a very small leakage current. The high-ohmic input does not influence the recessive level of the CAN network and allows an optimized EME performance of the entire HS CAN network (see also [Table 2](#)).

3.3.2 Power-up

The HS CAN transceiver TLE8250SJ powers up if the transmitter supply V_{CC} is connected to the device. By default the device powers up in power-save mode, due to the internal pull-up resistor on the NEN pin to V_{CC} .

In case the device needs to power-up to normal-operating mode, the NEN pin needs to be pulled active to logical “low” while the NRM pin is logical “high” (see [Figure 5](#)).

Functional description

3.3.3 Undervoltage on the transmitter supply V_{CC}

In case the transmitter supply V_{CC} falls below the threshold $V_{CC} < V_{CC(UV,F)}$, the transceiver TLE8250SJ can not provide the correct bus levels to the CANH and CANL anymore. The normal-mode receiver is powered by the transmitter supply V_{CC} . In case of insufficient V_{CC} supply the TLE8250SJ can neither transmit the CANH and CANL signals correctly to bus nor can it receive them properly. Therefore the TLE8250SJ powers down and blocks both, the transmitter and the receiver.

The transceiver TLE8250SJ powers up again, when the transmitter supply V_{CC} recovers from the undervoltage condition.

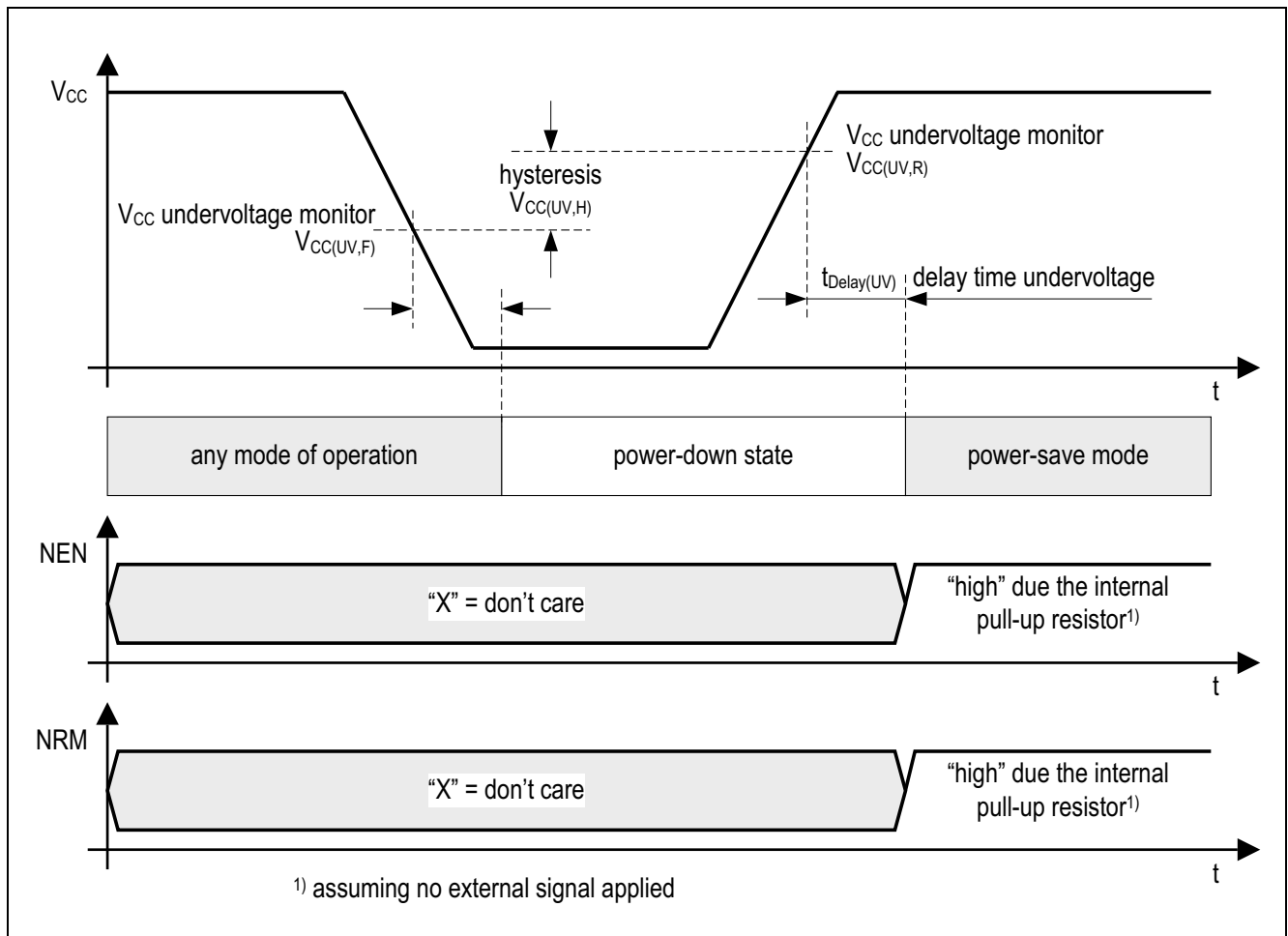

Figure 6 Undervoltage on the transmitter supply V_{CC}

4 Fail safe functions

4.1 Short circuit protection

The CANH and CANL bus outputs are short circuit proof, either against GND or a positive supply voltage. A current limiting circuit protects the transceiver against damages. If the device is heating up due to a continuous short on the CANH or CANL, the internal overtemperature protection switches off the bus transmitter.

4.2 Unconnected logic pins

All logic input pins have an internal pull-up resistor to V_{CC} . In case the V_{CC} supply is activated and the logical pins are open, the TLE8250SJ enters into the power-save mode by default. In power-save mode the transmitter of the TLE8250SJ is disabled and the bus bias is floating.

4.3 TxD time-out function

The TxD time-out feature protects the CAN bus against permanent blocking in case the logical signal on the TxD pin is continuously “low”. A continuous “low” signal on the TxD pin might have its root cause in a locked-up microcontroller or in a short circuit on the printed circuit board, for example. In normal-operating mode, a logical “low” signal on the TxD pin for the time $t > t_{TxD}$ enables the TxD time-out feature and the TLE8250SJ disables the transmitter (see [Figure 7](#)). The receiver is still active and the data on the bus continues to be monitored by the RxD output pin.

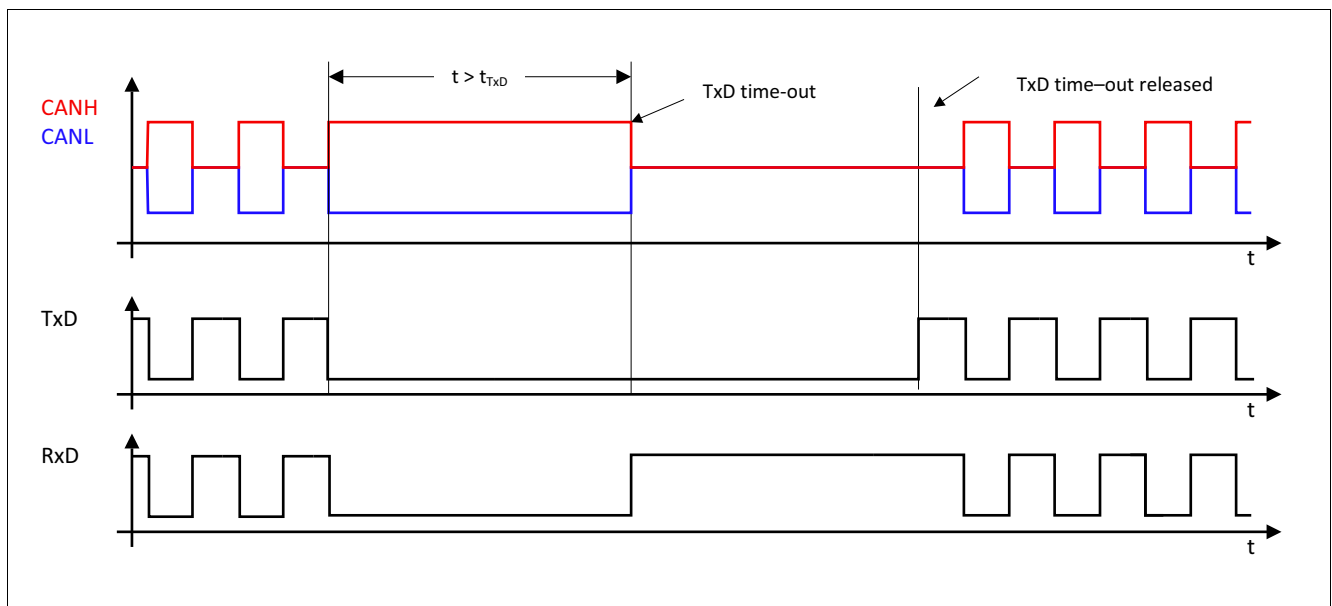

Figure 7 TxD time-out function

[Figure 7](#) illustrates how the transmitter is deactivated and activated again. A permanent “low” signal on the TxD input pin activates the TxD time-out function and deactivates the transmitter. To release the transmitter after a TxD time-out event the TLE8250SJ requires a signal change on the TxD input pin from logical “low” to logical “high”.

Fail safe functions

4.4 Overtemperature protection

The TLE8250SJ has an integrated overtemperature detection to protect the TLE8250SJ against thermal overstress of the transmitter. The overtemperature protection is active in normal-operating mode and disabled in power-save mode and receive-only mode. In case of an overtemperature condition, the temperature sensor will disable the transmitter (see [Figure 1](#)) while the transceiver remains in normal-operating mode.

After the device has cooled down the transmitter is activated again (see [Figure 8](#)). A hysteresis is implemented within the temperature sensor.

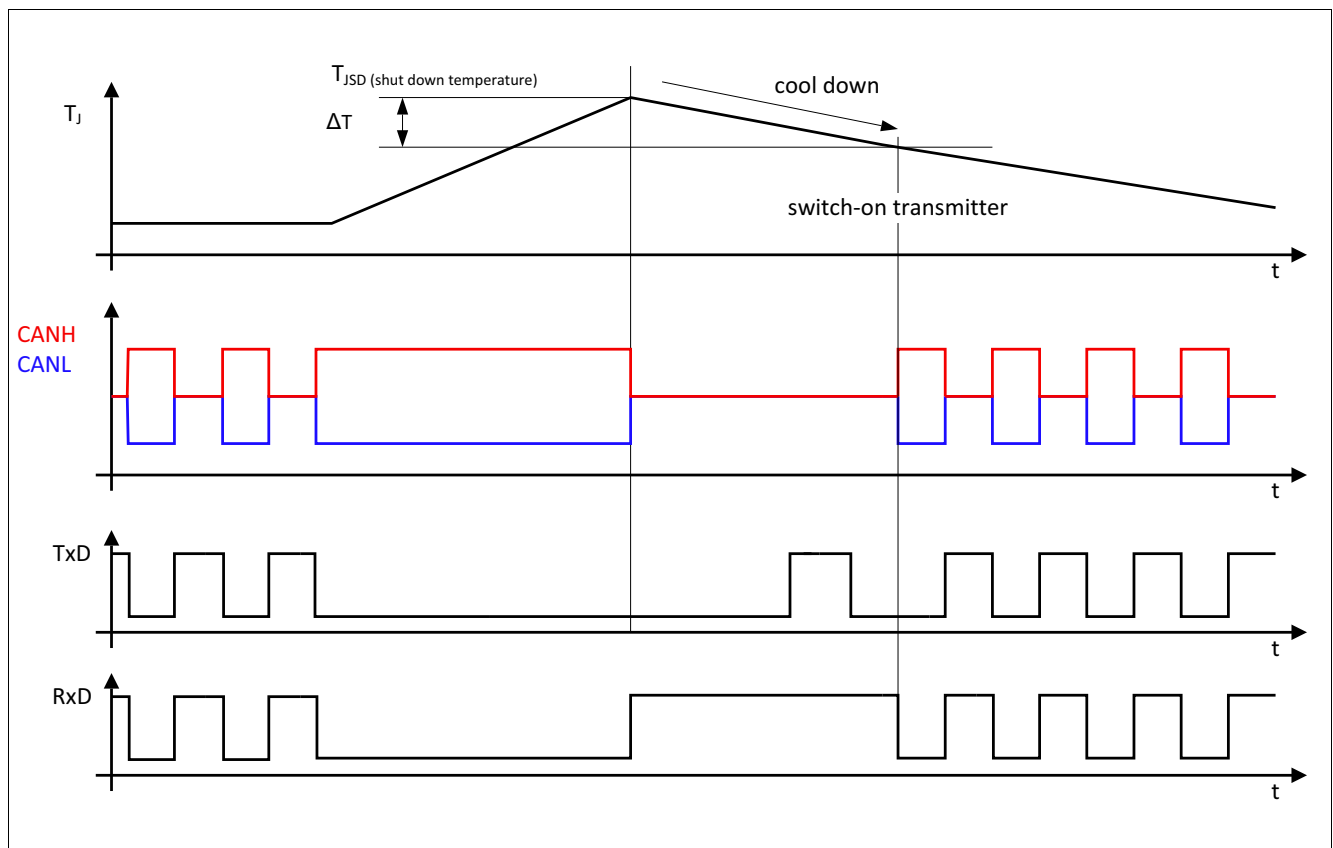

Figure 8 Overtemperature protection

4.5 Delay time for mode change

The HS CAN transceiver TLE8250SJ changes the mode of operation within the time window t_{Mode} . Depending on the selected mode of operation, the RxD output pin is set to logical “high” during the mode change. In this case the RxD output does not reflect the status on the CANH and CANL input pins (see as an example [Figure 12](#) and [Figure 13](#)).

General product characteristics

5 General product characteristics

5.1 Absolute maximum ratings

Table 3 Absolute maximum ratings voltages, currents and temperatures¹⁾

All voltages with respect to ground; positive current flowing into pin;
(unless otherwise specified).

Parameter	Symbol	Values			Unit	Note or Test Condition	Number
		Min.	Typ.	Max.			
Voltages							
Transmitter supply voltage	V_{CC}	-0.3	–	6.0	V	–	P_6.1.1
CANH DC voltage versus GND	V_{CANH}	-40	–	40	V	–	P_6.1.2
CANL DC voltage versus GND	V_{CANL}	-40	–	40	V	–	P_6.1.3
Differential voltage between CANH and CANL	V_{CAN_SDiff}	-40	–	40	V	–	P_6.1.4
Voltages at the input pins: NEN, NRM, TxD	V_{MAX_IN}	-0.3	–	6.0	V	–	P_6.1.5
Voltages at the output pin: RxD	V_{MAX_OUT}	-0.3	–	V_{CC}	V	–	P_6.1.6
Currents							
RxD output current	I_{RxD}	-20	–	20	mA	–	P_6.1.7
Temperatures							
Junction temperature	T_j	-40	–	150	°C	–	P_6.1.8
Storage temperature	T_S	-55	–	150	°C	–	P_6.1.9
ESD resistivity							
ESD immunity at CANH, CANL versus GND	$V_{ESD_HBM_CAN}$	-10	–	10	kV	HBM (100 pF via 1.5 kΩ) ²⁾	P_6.1.10
ESD immunity at all other pins	$V_{ESD_HBM_ALL}$	-2	–	2	kV	HBM (100 pF via 1.5 kΩ) ²⁾	P_6.1.11
ESD immunity to GND	V_{ESD_CDM}	-750	–	750	V	CDM ³⁾	P_6.1.12

1) Not subject to production test, specified by design.

2) ESD susceptibility, Human Body Model “HBM” according to ANSI/ESDA/JEDEC JS-001.

3) ESD susceptibility, Charge Device Model “CDM” according to EIA/JESD22-C101 or ESDA STM5.3.1.

Note: Stresses above the ones listed here may cause permanent damage to the device. Exposure to absolute maximum rating conditions for extended periods may affect device reliability. Integrated protection functions are designed to prevent IC destruction under fault conditions described in the data sheet. Fault conditions are considered as “outside” normal-operating range. Protection functions are not designed for continuous repetitive operation.

General product characteristics

5.2 Functional range

Table 4 Functional range

Parameter	Symbol	Values			Unit	Note or Test Condition	Number
		Min.	Typ.	Max.			
Supply voltages							
Transmitter supply voltage	V_{CC}	4.5	–	5.5	V	–	P_6.2.1
Thermal parameters							
Junction temperature	T_j	-40	–	150	°C	¹⁾	P_6.2.2

1) Not subject to production test, specified by design.

Note: Within the functional range the IC operates as described in the circuit description. The electrical characteristics are specified within the conditions given in the related electrical characteristics table.

5.3 Thermal resistance

Note: This thermal data was generated in accordance with JEDEC JESD51 standards. For more information, please visit www.jedec.org.

Table 5 Thermal resistance¹⁾

Parameter	Symbol	Values			Unit	Note or Test Condition	Number
		Min.	Typ.	Max.			
Thermal resistances							
Junction to ambient PG-DSO-8	R_{thJA}	–	130	–	K/W	²⁾	P_6.3.2
Thermal Shutdown (junction temperature)							
Thermal shutdown temperature	T_{JSD}	150	175	200	°C	–	P_6.3.3
Thermal shutdown hysteresis	ΔT	–	10	–	K	–	P_6.3.4

1) Not subject to production test, specified by design.

2) Specified R_{thJA} value is according to Jedec JESD51-2,-7 at natural convection on FR4 2s2p board. The product (TLE8250SJ) was simulated on a 76.2 × 114.3 × 1.5 mm³ board with 2 inner copper layers (2 × 70 μm Cu, 2 × 35 μm Cu).

Electrical characteristics

6 Electrical characteristics

6.1 Functional device characteristics

Table 6 Electrical characteristics

4.5 V < V_{CC} < 5.5 V; $R_L = 60 \Omega$; $-40^\circ\text{C} < T_j < 150^\circ\text{C}$; all voltages with respect to ground; positive current flowing into pin; unless otherwise specified.

Parameter	Symbol	Values			Unit	Note or Test Condition	Number
		Min.	Typ.	Max.			
Current consumption							
Current consumption at V_{CC} normal-operating mode	I_{CC}	–	2.6	5	mA	Recessive state, $V_{TXD} = V_{NRM} = V_{CC}$, $V_{NEN} = 0\text{ V}$	P_7.1.1
Current consumption at V_{CC} normal-operating mode	I_{CC}	–	38	60	mA	Dominant state, $V_{TXD} = V_{NEN} = 0\text{ V}$, $V_{NRM} = V_{CC}$	P_7.1.2
Current consumption at V_{CC} receive-only mode	$I_{CC(ROM)}$	–	2	3	mA	$V_{NEN} = V_{NRM} = 0\text{ V}$	P_7.1.3
Current consumption at V_{CC} power-save mode	$I_{CC(PSM)}$	–	5	12	μA	$V_{TXD} = V_{NEN} = V_{NRM} = V_{CC}$	P_7.1.4
Supply resets							
V_{CC} undervoltage monitor rising edge	$V_{CC(UV,R)}$	3.8	4.0	4.3	V	–	P_7.1.5
V_{CC} undervoltage monitor falling edge	$V_{CC(UV,F)}$	3.65	3.85	4.3	V	–	P_7.1.6
V_{CC} undervoltage monitor hysteresis	$V_{CC(UV,H)}$	–	150	–	mV	¹⁾	P_7.1.7
V_{CC} undervoltage delay time	$t_{\text{Delay}(UV)}$	–	–	100	μs	¹⁾ (see Figure 6)	P_7.1.8
Receiver output RxD							
“High” level output current	$I_{RD,H}$	–	-4	-2	mA	$V_{RXD} = V_{CC} - 0.4\text{ V}$, $V_{\text{Diff}} < 0.5\text{ V}$	P_7.1.9
“Low” level output current	$I_{RD,L}$	2	4	–	mA	$V_{RXD} = 0.4\text{ V}$, $V_{\text{Diff}} > 0.9\text{ V}$	P_7.1.10

Electrical characteristics

Table 6 Electrical characteristics (cont'd)

4.5 V < V_{CC} < 5.5 V; R_L = 60 Ω; -40 °C < T_j < 150°C; all voltages with respect to ground; positive current flowing into pin; unless otherwise specified.

Parameter	Symbol	Values			Unit	Note or Test Condition	Number
		Min.	Typ.	Max.			
Transmission input TxD							
“High” level input voltage threshold	V _{TxD,H}	–	0.5 × V _{CC}	0.7 × V _{CC}	V	Recessive state	P_7.1.11
“Low” level input voltage threshold	V _{TxD,L}	0.3 × V _{CC}	0.4 × V _{CC}	–	V	Dominant state	P_7.1.12
Pull-up resistance	R _{TxD}	10	25	50	kΩ	–	P_7.1.13
Input hysteresis	V _{HYS(TxD)}	–	450	–	mV	¹⁾	P_7.1.14
Input capacitance	C _{TxD}	–	–	10	pF	¹⁾	P_7.1.15
TxD permanent dominant time-out	t _{TxD}	4.5	–	16	ms	Normal-operating mode	P_7.1.16
Not enable input NEN							
“High” level input voltage threshold	V _{NEN,H}	–	0.5 × V _{CC}	0.7 × V _{CC}	V	Power-save mode	P_7.1.17
“Low” level input voltage threshold	V _{NEN,L}	0.3 × V _{CC}	0.4 × V _{CC}	–	V	Normal-operating mode, receive-only mode	P_7.1.18
Pull-up resistance	R _{NEN}	10	25	50	kΩ	–	P_7.1.19
Input capacitance	C _{NEN}	–	–	10	pF	¹⁾	P_7.1.20
Input hysteresis	V _{HYS(NEN)}	–	200	–	mV	¹⁾	P_7.1.21
Not receive-only input NRM							
“High” level input voltage threshold	V _{NRM,H}	–	0.5 × V _{CC}	0.7 × V _{CC}	V	Normal-operating mode, power-save mode	P_7.1.22
“Low” level input voltage threshold	V _{NRM,L}	0.3 × V _{CC}	0.4 × V _{CC}	–	V	Receive-only mode, power-save mode	P_7.1.23
Pull-up resistance	R _{NRM}	10	25	50	kΩ	–	P_7.1.24
Input capacitance	C _{NRM}	–	–	10	pF	¹⁾	P_7.1.25
Input hysteresis	V _{NRM(HYS)}	–	200	–	mV	¹⁾	P_7.1.26
Bus receiver							
Differential receiver threshold dominant normal-operating mode and receive-only mode	V _{Diff_D}	–	0.75	0.9	V	²⁾	P_7.1.27
Differential receiver threshold recessive normal-operating mode and receive-only mode	V _{Diff_R}	0.5	0.66	–	V	²⁾	P_7.1.28
Differential range dominant Normal-operating mode	V _{Diff_D_Range}	0.9	–	8.0	V	^{1) 2)}	P_7.1.29

Electrical characteristics

Table 6 Electrical characteristics (cont'd)

4.5 V < V_{CC} < 5.5 V; $R_L = 60 \Omega$; $-40 \text{ }^\circ\text{C} < T_j < 150 \text{ }^\circ\text{C}$; all voltages with respect to ground; positive current flowing into pin; unless otherwise specified.

Parameter	Symbol	Values			Unit	Note or Test Condition	Number
		Min.	Typ.	Max.			
Differential range recessive Normal-operating mode	$V_{\text{Diff_R_Range}}$	-3.0	-	0.5	V	^{1) 2)}	P_7.1.30
Common mode range	CMR	-12	-	12	V	$V_{CC} = 5 \text{ V}$	P_7.1.31
Differential receiver hysteresis normal-operating mode	$V_{\text{Diff,hys}}$	-	90	-	mV	¹⁾	P_7.1.32
CANH, CANL input resistance	R_i	10	20	30	k Ω	Recessive state	P_7.1.33
Differential input resistance	R_{Diff}	20	40	60	k Ω	Recessive state	P_7.1.34
Input resistance deviation between CANH and CANL	ΔR_i	- 1	-	1	%	¹⁾ Recessive state	P_7.1.35
Input capacitance CANH, CANL versus GND	C_{In}	-	20	40	pF	¹⁾ $V_{\text{TXD}} = V_{CC}$	P_7.1.36
Differential input capacitance	C_{InDiff}	-	10	20	pF	¹⁾ $V_{\text{TXD}} = V_{CC}$	P_7.1.37

Bus transmitter

CANL/CANH recessive output voltage normal-operating mode	$V_{\text{CANL/H}}$	2.0	2.5	3.0	V	$V_{\text{TXD}} = V_{CC}$, no load	P_7.1.38
CANH, CANL recessive output voltage difference normal-operating mode	$V_{\text{Diff_NM}}$	-500	-	50	mV	$V_{\text{TXD}} = V_{CC}$, no load	P_7.1.39
CANL dominant output voltage normal-operating mode	V_{CANL}	0.5	-	2.25	V	$V_{\text{TXD}} = 0 \text{ V}$	P_7.1.40
CANH dominant output voltage normal-operating mode	V_{CANH}	2.75	-	4.5	V	$V_{\text{TXD}} = 0 \text{ V}$	P_7.1.41
CANH, CANL dominant output voltage difference normal-operating mode according to ISO 11898-2:2016 $V_{\text{Diff}} = V_{\text{CANH}} - V_{\text{CANL}}$	V_{Diff}	1.5	-	3.0	V	$V_{\text{TXD}} = 0 \text{ V}$, $50 \Omega < R_L < 65 \Omega$, $4.75 < V_{CC} < 5.25 \text{ V}$	P_7.1.42
CANH, CANL dominant output voltage difference normal-operating mode $V_{\text{Diff}} = V_{\text{CANH}} - V_{\text{CANL}}$	$V_{\text{Diff_EXT}}$	1.4	-	3.3	V	$V_{\text{TXD}} = 0 \text{ V}$, $45 \Omega < R_L < 70 \Omega$, $4.75 < V_{CC} < 5.25 \text{ V}$	P_7.1.43

Electrical characteristics

Table 6 Electrical characteristics (cont'd)

4.5 V < V_{CC} < 5.5 V; R_L = 60 Ω; -40 °C < T_j < 150°C; all voltages with respect to ground; positive current flowing into pin; unless otherwise specified.

Parameter	Symbol	Values			Unit	Note or Test Condition	Number
		Min.	Typ.	Max.			
Differential voltage dominant high extended bus load Normal-operating mode	V _{Diff_HEX_BL}	1.5	–	5.0	V	¹⁾ V _{TxD} = 0 V, R _L = 2240Ω, 4.75 V < V _{CC} < 5.25 V, static behavior	P_7.1.44
Driver dominant symmetry normal-operating mode V _{SYM} = V _{CANH} + V _{CANL}	V _{SYM}	4.5	5	5.5	V	V _{CC} = 5.0 V, V _{TxD} = 0 V	P_7.1.45
CANL short circuit current	I _{CANLsc}	40	75	100	mA	V _{CANLshort} = 18 V, V _{CC} = 5.0 V, t < t _{TxD} , V _{TxD} = 0 V	P_7.1.46
CANH short circuit current	I _{CANHsc}	-100	-75	-40	mA	V _{CANHshort} = -3 V, V _{CC} = 5.0 V, t < t _{TxD} , V _{TxD} = 0 V	P_7.1.47
Leakage current, CANH	I _{CANH,lk}	-5	–	5	μA	V _{CC} = 0 V, 0 V < V _{CANH} < 5 V, V _{CANH} = V _{CANL}	P_7.1.48
Leakage current, CANL	I _{CANL,lk}	-5	–	5	μA	V _{CC} = 0 V, 0 V < V _{CANL} < 5 V, V _{CANH} = V _{CANL}	P_7.1.49

Dynamic CAN-transceiver characteristics

Propagation delay TxD-to-RxD “low” (“recessive to dominant)	t _{Loop(H,L)}	–	170	230	ns	C _L = 100 pF, 4.75 V < V _{CC} < 5.25 V, C _{RxD} = 15 pF	P_7.1.50
Propagation delay TxD-to-RxD “high” (dominant to recessive)	t _{Loop(L,H)}	–	170	230	ns	C _L = 100 pF, 4.75 V < V _{CC} < 5.25 V, C _{RxD} = 15 pF	P_7.1.51
Propagation delay TxD “low” to bus dominant	t _{d(L),T}	–	90	140	ns	C _L = 100 pF, 4.75 V < V _{CC} < 5.25 V, C _{RxD} = 15 pF	P_7.1.52
Propagation delay TxD “high” to bus recessive	t _{d(H),T}	–	90	140	ns	C _L = 100 pF, 4.75 V < V _{CC} < 5.25 V, C _{RxD} = 15 pF	P_7.1.53
Propagation delay bus dominant to RxD “low”	t _{d(L),R}	–	90	140	ns	C _L = 100 pF, 4.75 V < V _{CC} < 5.25 V, C _{RxD} = 15 pF	P_7.1.54
Propagation delay bus recessive to RxD “high”	t _{d(H),R}	–	90	140	ns	C _L = 100 pF, 4.75 V < V _{CC} < 5.25 V, C _{RxD} = 15 pF	P_7.1.55

Delay times

Electrical characteristics

Table 6 Electrical characteristics (cont'd)

4.5 V < V_{CC} < 5.5 V; $R_L = 60 \Omega$; $-40^\circ\text{C} < T_j < 150^\circ\text{C}$; all voltages with respect to ground; positive current flowing into pin; unless otherwise specified.

Parameter	Symbol	Values			Unit	Note or Test Condition	Number
		Min.	Typ.	Max.			
Delay time for mode change	t_{Mode}	–	–	20	μs	¹⁾ (see Figure 12 and Figure 13)	P_7.1.56

CAN FD Characteristics

Received recessive bit width at 2 MBit/s	$t_{\text{Bit(RxD)}}_{2\text{MB}}$	430	500	530	ns	$C_L = 100 \text{ pF}$, $4.75 \text{ V} < V_{CC} < 5.25 \text{ V}$, $C_{\text{RxD}} = 15 \text{ pF}$, $t_{\text{Bit}} = 500 \text{ ns}$, (see Figure 11)	P_7.1.57
Transmitted recessive bit width at 2 MBit/s	$t_{\text{Bit(Bus)}}_{2\text{MB}}$	450	500	530	ns	$C_L = 100 \text{ pF}$, $4.75 \text{ V} < V_{CC} < 5.25 \text{ V}$, $C_{\text{RxD}} = 15 \text{ pF}$, $t_{\text{Bit}} = 500 \text{ ns}$, (see Figure 11)	P_7.1.58
Receiver timing symmetry at 2 MBit/s $\Delta t_{\text{Rec}} = t_{\text{Bit(RxD)}} - t_{\text{Bit(Bus)}}$	$\Delta t_{\text{Rec}_2\text{MB}}$	-45	–	20	ns	$C_L = 100 \text{ pF}$, $4.75 \text{ V} < V_{CC} < 5.25 \text{ V}$, $C_{\text{RxD}} = 15 \text{ pF}$, $t_{\text{Bit}} = 500 \text{ ns}$, (see Figure 11)	P_7.1.59

- 1) Not subject to production test, specified by design.
- 2) In respect to the common mode range.

Electrical characteristics

6.2 Diagrams

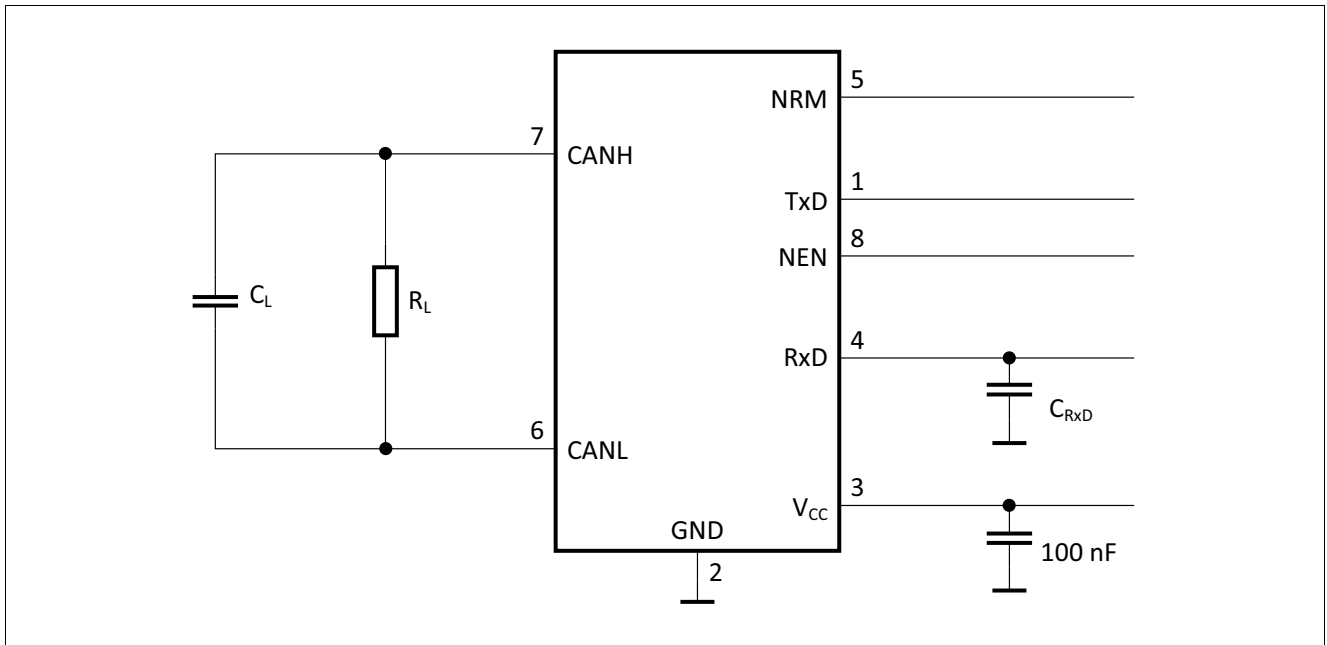

Figure 9 Test circuits for dynamic characteristics

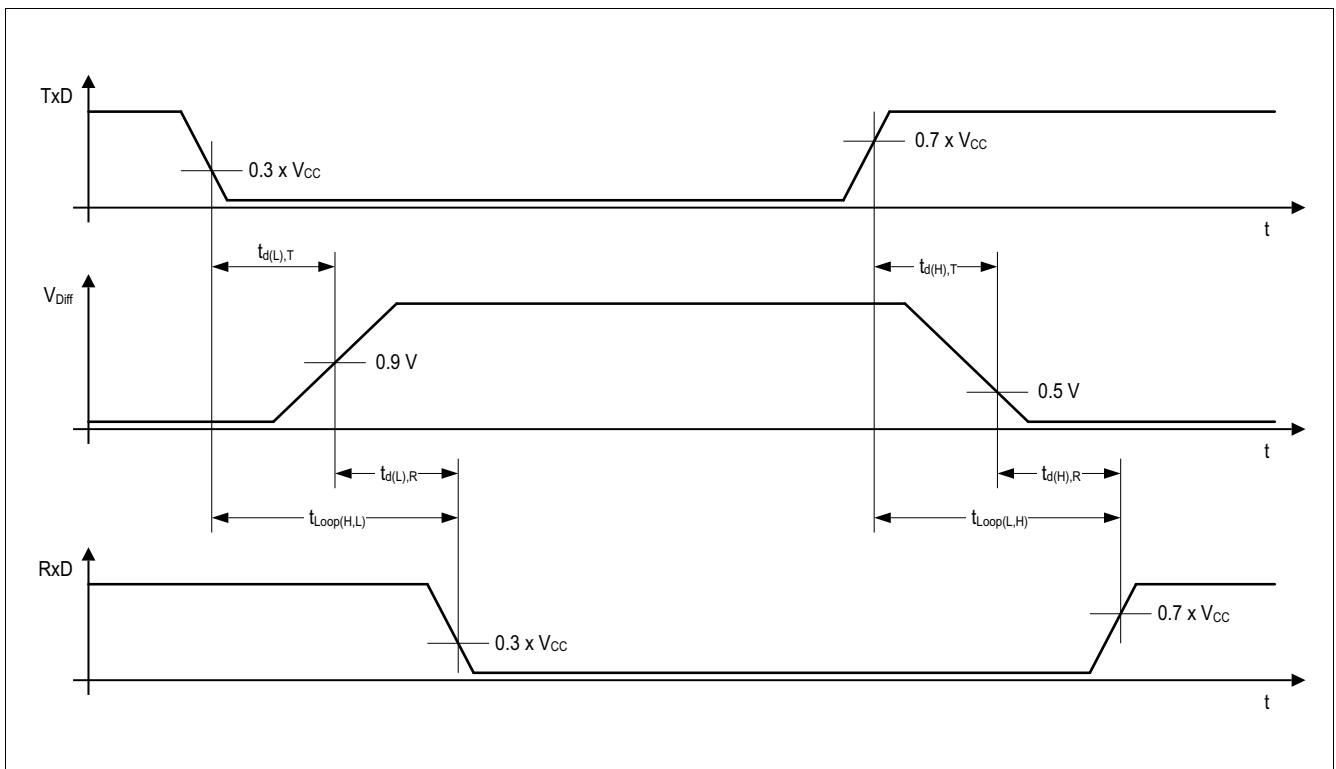

Figure 10 Timing diagrams for dynamic characteristics

Electrical characteristics

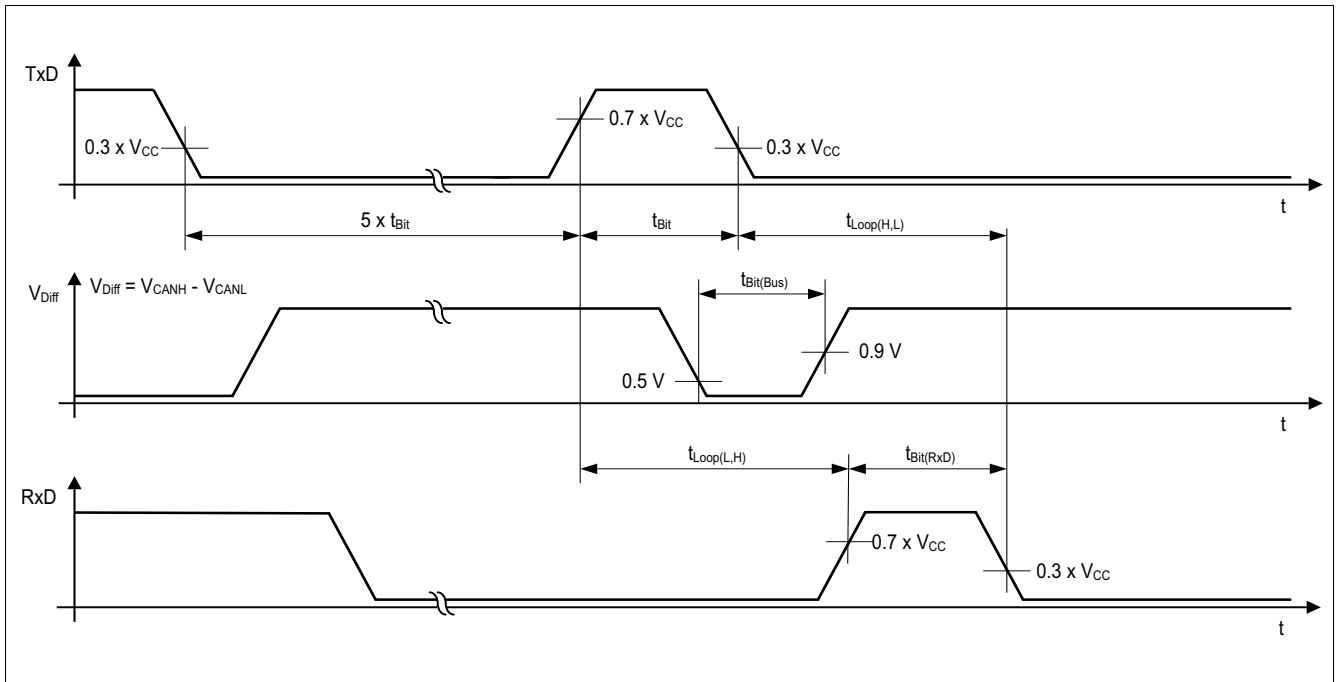

Figure 11 Recessive bit width - five dominant bits followed by one recessive bit

7 Application information

7.1 ESD robustness according to IEC61000-4-2

Tests for ESD robustness according to IEC61000-4-2 “Gun test” (150 pF, 330 Ω) have been performed. The results and test conditions are available in a separate test report.

Table 7 ESD robustness according to IEC61000-4-2

Performed test	Result	Unit	Remarks
Electrostatic discharge voltage at pin CANH and CANL versus GND	≥ +8	kV	¹⁾ Positive pulse
Electrostatic discharge voltage at pin CANH and CANL versus GND	≤ -8	kV	¹⁾ Negative pulse

1) ESD susceptibility “ESD GUN” according to GIFT / ICT paper: “EMC Evaluation of CAN Transceivers, version 03/02/IEC TS62228”, section 4.3. (DIN EN61000-4-2)
Tested by external test facility (IBEE Zwickau).

Application information

7.2 Application example

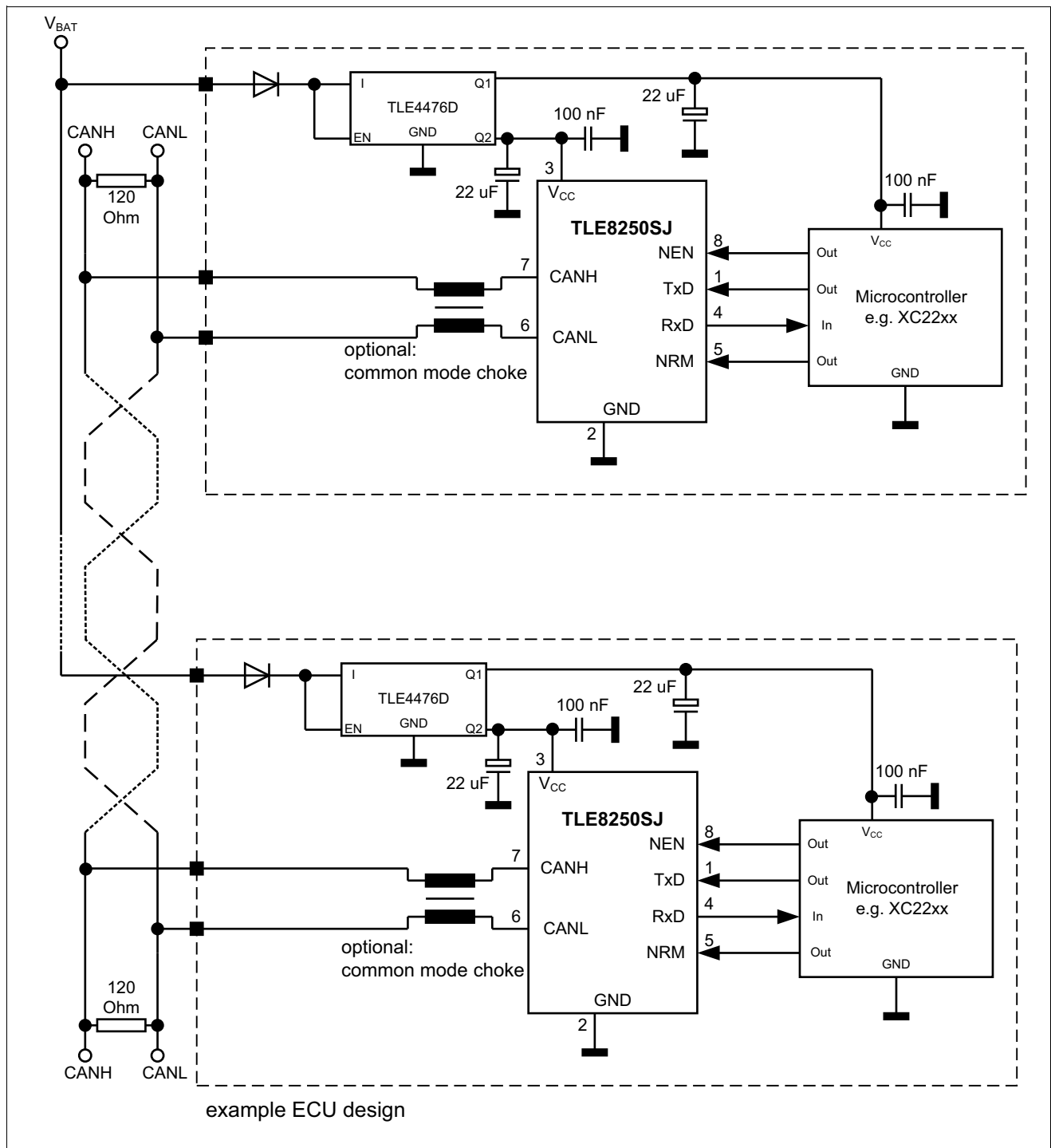

Figure 12 Application circuit

Application information

7.3 Examples for mode changes

Changing the status on the NRM or NEN input pin triggers a change of the operating mode, disregarding the actual signal on the CANH, CANL and TxD pins (see also [Chapter 3.2](#)).

Mode changes are triggered by the NRM pin and NEN pin, when the device TLE8250SJ is fully supplied. Setting the NEN pin to logical “low” and the NRM pin to logical “high” changes the mode of operation to normal-operating mode:

- The mode change is executed independently of the signal on the HS CAN bus. The CANH, CANL inputs may be either dominant or recessive. They can be also permanently shorted to GND or V_{CC} .
- A mode change is performed independently of the signal on the TxD input. The TxD input may be either logical “high” or “low”.

Analog to that, changing the NEN input pin to logical “high” changes the mode of operation to the power-save mode. Changing the NEN input pin and the NRM input pin to logical “low” changes the mode of operation to the receive-only mode. Both mode changes are independent on the signals at the CANH, CANL and TxD pins.

Notes

1. *In case the TxD signal is “low” setting the NRM input pin to logical “high” and the NEN input pin to logical “low” changes the device to normal-operating mode and drives a dominant signal to the HS CAN bus”.*
2. *The TxD time-out is only effective in normal-operating mode. The TxD time-out timer starts when the TLE8250SJ enters normal-operating mode and the TxD input is set to logical “low”.*

Application information

7.3.1 Mode change while the TxD signal is “low”

The example in [Figure 13](#) shows a mode change to normal-operating mode while the TxD input is logical “low”. The HS CAN signal is recessive, assuming all other HS CAN bus subscribers are also sending a recessive bus signal.

While the transceiver TLE8250SJ is in power-save mode, the transmitter and the normal-mode receiver are turned off. The TLE8250SJ drives no signal to the HS CAN bus nor does it receive any signal from the HS CAN bus. Changing the NEN to logical “low” turns the mode of operation to normal-operating mode, while the TxD input signal remains logical “low”. The transmitter and the normal-mode receiver remain disabled until the mode transition is completed. In normal-operating mode the transceiver and the normal-mode receiver are active. The “low” signal on the TxD input drives a dominant signal to the HS CAN bus and the RxD output pin becomes logical “low”, following the dominant signal on the HS CAN bus.

Changing the mode of operation from normal-operating mode to receive-only mode by setting the NRM input pin to “low”, disables the transmitter and the TxD input, but the normal-mode receiver and the RxD output remain active. The HS CAN bus becomes recessive since the transmitter is disabled. The RxD input indicates the recessive HS CAN bus signal by a logical “high” output signal (see also the example in [Figure 13](#)).

Mode changes between the power-save mode on the one side and the normal-operating mode or the receive-only mode on the other side, disable the transmitter and the normal-mode receiver. No signal can be driven to the HS CAN bus nor can it be received from the HS CAN bus. Mode changes between the normal-operating mode and the receive-only mode disable the transmitter and the normal mode receiver remains active. The HS CAN transceiver TLE8250SJ monitors the HS CAN bus also during the mode transition from normal-operating mode to receive-only mode and vice versa.

7.3.2 Mode change while the bus signal is dominant

The example in [Figure 14](#) shows a mode change while the bus is dominant and the TxD input signal is set to logical “high”.

While the transceiver TLE8250SJ is in power-save mode, the transmitter and the normal-mode receiver are turned off. The TLE8250SJ drives no signal to the HS CAN bus nor does it receive any signal from the HS CAN bus. Changing the NEN to logical “low” turns the mode of operation to normal-operating mode, while the TxD input signal remains logical “high”. The transmitter and the normal-mode receiver remain disabled until the mode transition is completed. In normal-operating mode the transceiver and the receiver are active and therefor the RxD output changes to logical “low” indicating the dominant signal on the HS CAN bus.

Changing the mode of operation from normal-operating mode to receive-only mode by setting the NRM input pin to “low”, disables the transmitter and the TxD input, but the normal-mode receiver and the RxD output remain active. Since the dominant signal on the HS CAN bus is driven by another HS CAN bus subscriber, the bus remains dominant and the RxD input indicates the dominant HS CAN bus signal by a logical “low” output signal (see also the example in [Figure 14](#)).

Application information

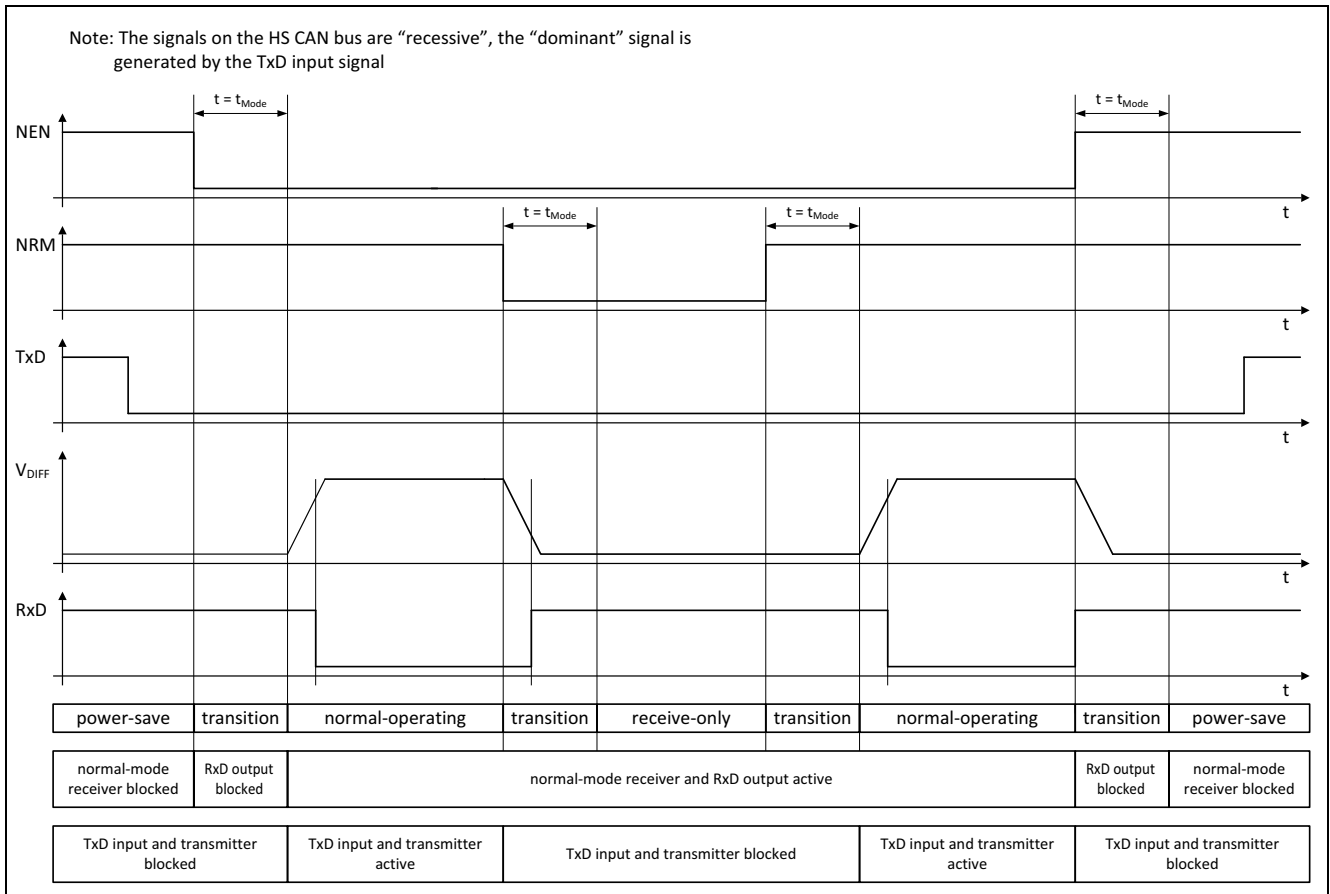

Figure 13 Example for a mode change while the TxD is “low”

Application information

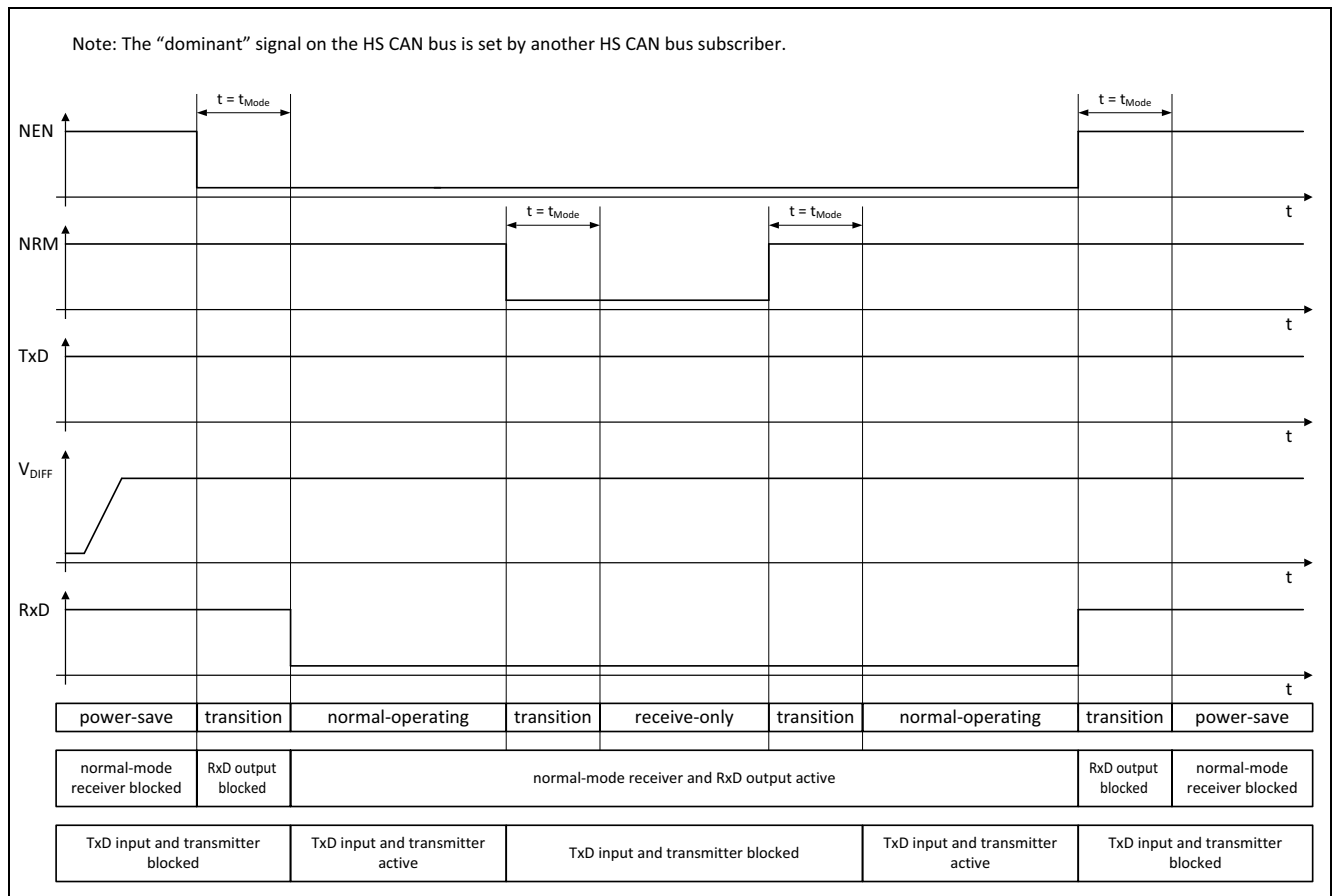

Figure 14 Example for a mode change while the HS CAN is dominant

7.4 Further application information

- Please contact us for information regarding the pin FMEA.
- Existing application note.
- For further information you may visit: <http://www.infineon.com/>

Package information

8 Package information

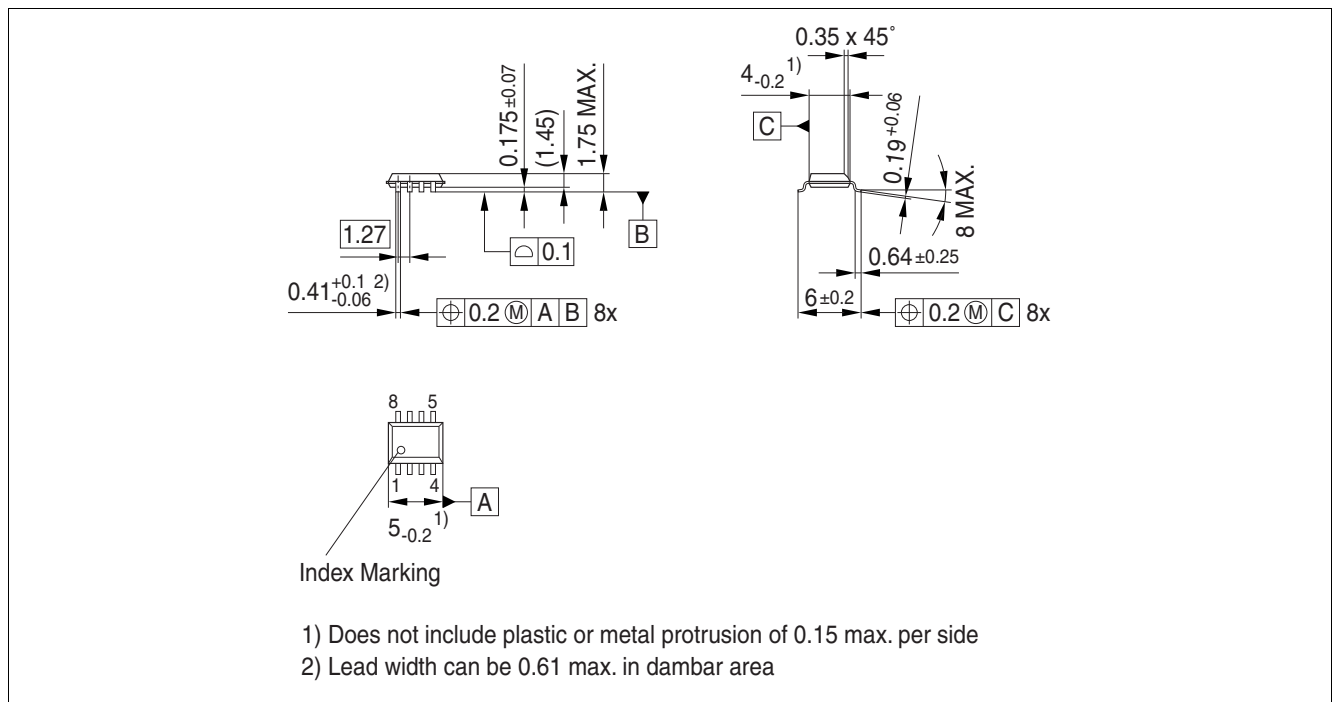

Figure 15 PG-DSO-8 (plastic dual small outline)¹⁾

Green Product (RoHS compliant)

To meet the world-wide customer requirements for environmentally friendly products and to be compliant with government regulations the device is available as a green product. Green products are RoHS-compliant (i.e. Pb-free finish on leads and suitable for Pb-free soldering according to IPC/JEDEC J-STD-020).

Further information on packages

<https://www.infineon.com/packages>

1) Dimensions in mm

Revision history

9 Revision history

Revision	Date	Changes
1.01	2020-02-14	Datasheet updated: editorial changes.
1.0	2016-07-15	Datasheet created.

Trademarks

All referenced product or service names and trademarks are the property of their respective owners.

Edition 2020-02-14

Published by

Infineon Technologies AG

81726 Munich, Germany

© 2020 Infineon Technologies AG.

All Rights Reserved.

Do you have a question about any aspect of this document?

Email: erratum@infineon.com

Document reference

Z8F55233326

IMPORTANT NOTICE

The information given in this document shall in no event be regarded as a guarantee of conditions or characteristics ("Beschaffheitsgarantie").

With respect to any examples, hints or any typical values stated herein and/or any information regarding the application of the product, Infineon Technologies hereby disclaims any and all warranties and liabilities of any kind, including without limitation warranties of non-infringement of intellectual property rights of any third party.

In addition, any information given in this document is subject to customer's compliance with its obligations stated in this document and any applicable legal requirements, norms and standards concerning customer's products and any use of the product of Infineon Technologies in customer's applications.

The data contained in this document is exclusively intended for technically trained staff. It is the responsibility of customer's technical departments to evaluate the suitability of the product for the intended application and the completeness of the product information given in this document with respect to such application.

For further information on technology, delivery terms and conditions and prices, please contact the nearest Infineon Technologies Office (www.infineon.com).

WARNINGS

Due to technical requirements products may contain dangerous substances. For information on the types in question please contact your nearest Infineon Technologies office.

Except as otherwise explicitly approved by Infineon Technologies in a written document signed by authorized representatives of Infineon Technologies, Infineon Technologies' products may not be used in any applications where a failure of the product or any consequences of the use thereof can reasonably be expected to result in personal injury.

X-ON Electronics

Largest Supplier of Electrical and Electronic Components

Click to view similar products for [CAN Interface IC](#) category:

Click to view products by [Infineon](#) manufacturer:

Other Similar products are found below :

[416694H](#) [IL41050TA-1E](#) [TJA1042T1J](#) [TJA1042T31J](#) [SN65LBC031DG4](#) [SN65HVD267DR](#) [TJA1050T/CM,118](#) [MAX13051ESA+T](#)
[SJA1000T/N1.118](#) [MCP2561FD-EP](#) [LTM2889IY-5#PBF](#) [IA82527PQF44AR2](#) [ADM3053BRWZ-REEL7](#) [ADM3051CRZ-REEL7](#)
[IA82527PLC44AR2](#) [LT3960JMSE#TRPBF](#) [LT3960JMSE#PBF](#) [TJA1040TCM,118](#) [SIT1050TK](#) [SIT1040TK](#) [MCP25625-ESS](#)
[MAX3053ESA+T](#) [MAX3057ASA+T](#) [MCP2515T-I/ST](#) [NCV7341D21R2G](#) [MC33897CTEFR2](#) [MAX3056ASD+](#) [MAX3054ASD+](#)
[MAX3055ASD+](#) [MAX3051ESA+T](#) [MAX13054ESA+](#) [MAX3051EKA+T](#) [MCP2510-E/SO](#) [MCP2510-I/P](#) [MCP2510-I/SO](#) [MCP2515-I/P](#)
[MCP2515-I/SO](#) [MCP2515-I/ST](#) [MCP2515T-I/SO](#) [MCP2551-E/P](#) [MCP2551-E/SN](#) [MCP2551-I/P](#) [MCP2551-I/SN](#) [MCP2561-E/P](#)
[MCP2561T-ESN](#) [MCP2562FD-E/SN](#) [MCP2562T-ESN](#) [MCP2515-E/ML](#) [PCA82C250T/YM,118](#) [PCA82C251T/YM,118](#)