

48 V MOTIX™ Gate Driver TLE9140EQW Evaluation Board

About this document

Scope and purpose

This document describes how to use the **TLE9140EQW evaluation board v2.0**.

Intended audience

This document is intended for electronic engineers who want to evaluate a 48 V 3-phase gater driver.

Related information

Table 1 Supplementary links and document references

Reference	Description
TLE9140EQW datasheet	Datasheet contains reference information for the 48 V MOTIX™ 3-phase gate driver TLE9140EQW
TLE987x Product Page	All information of MOTIX™ MUC

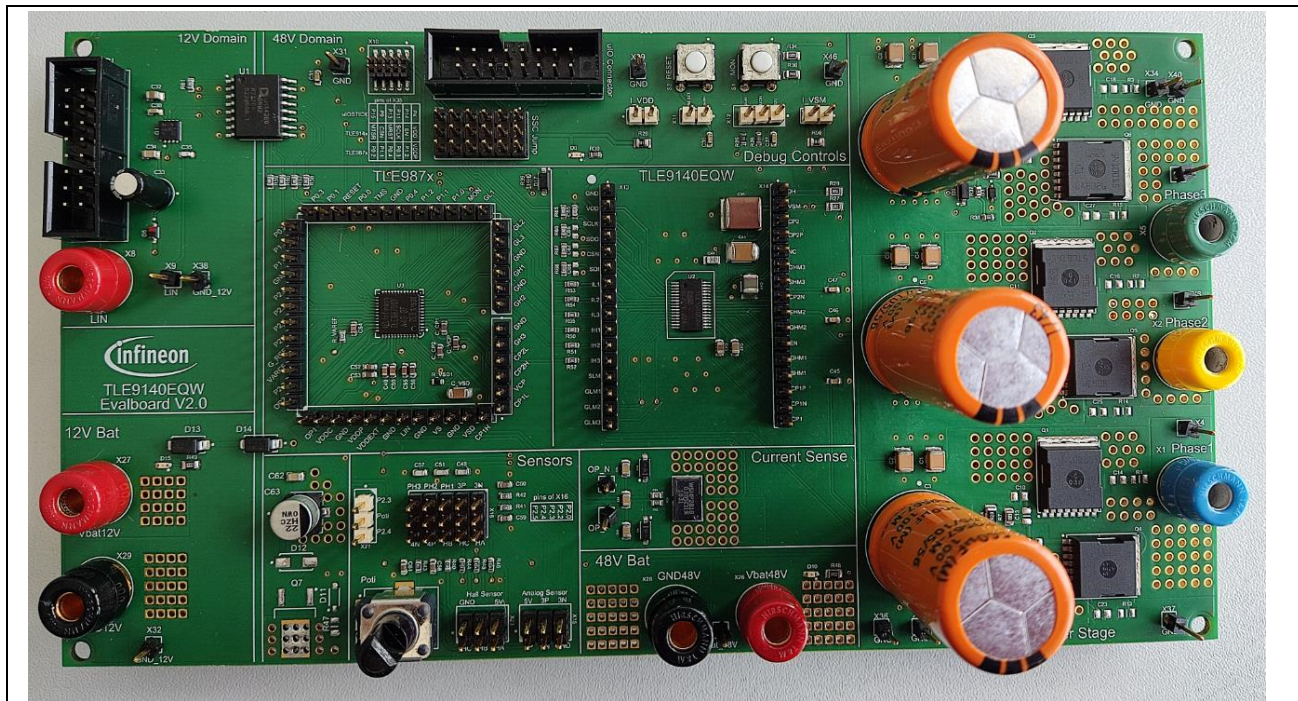

Figure 1 48 V MOTIX™ gate driver TLE9140EQW evaluation board

Important Notice

Important Notice

"Evaluation boards and reference boards" mean products embedded on a printed circuit board (PCB) for demonstration and / or evaluation purposes, which include, without limitation, demonstration, reference and evaluation boards, kits and design (collectively referred to as "reference board").

Environmental conditions have been considered in the design of the evaluation boards and reference boards provided by Infineon Technologies. The design of the evaluation boards and reference boards has been tested by Infineon Technologies only as described in this document. The design is not qualified in terms of safety requirements, manufacturing and operation over the entire operating temperature range or lifetime.

The evaluation boards and reference boards provided by Infineon Technologies are subject to functional testing only under typical load conditions. Evaluation boards and reference boards are not subject to the same procedures as regular products regarding returned material analysis (RMA), process change notification (PCN) and product discontinuation (PD).

Evaluation boards and reference boards are not commercialized products, and are solely intended for evaluation and testing purposes. In particular, they may not be used for reliability testing or production. The evaluation boards and reference boards may therefore not comply with CE or similar standards (including but not limited to the EMC Directive 2004/EC/108 and the EMC Act) and may not fulfill other requirements of the country in which they are operated by the customer. The customer must ensure that all evaluation boards and reference boards will be handled in a way which is compliant with the relevant requirements and standards of the country in which they are operated.

The evaluation boards and reference boards as well as the information provided in this document are addressed only to qualified and skilled technical staff, for laboratory usage, and must be used and managed according to the terms and conditions set forth in this document and in other related documentation supplied with the respective evaluation board and reference board.

It is the responsibility of the customer's technical departments to evaluate the suitability of the evaluation boards and reference boards for the intended application, and to evaluate the completeness and correctness of the information provided in this document with respect to such application.

The customer is obliged to ensure that the use of the evaluation boards and reference boards does not cause any harm to persons or third-party property.

The evaluation boards and reference boards and any information in this document is provided "as is" and Infineon Technologies disclaims any warranties, express or implied, including but not limited to warranties of non-infringement of third-party rights and implied warranties of fitness for any purpose, or for merchantability.

Infineon Technologies may not be responsible for any damages resulting from the use of the evaluation boards and reference boards and/or from any information provided in this document. The customer is obliged to defend, indemnify and hold Infineon Technologies harmless from and against any claims or damages arising out of or resulting from any use thereof.





Infineon Technologies reserves the right to modify this document and/or any information provided herein at any time without further notice.

Safety precautions

Safety precautions

Note: Please note the following warnings regarding the hazards associated with development system.

Table 2 Safety precautions

	Caution
	The heat sink and device surfaces of the evaluation or reference board may become hot during testing. Hence, necessary precautions are required while handling the board. Failure to comply may cause injury.
	Only personnel familiar with the drive, power electronics and associated machinery should plan, install, commission and subsequently service the system. Failure to comply may result in personal injury and/or equipment damage.
	The evaluation or reference board contains parts and assemblies sensitive to electrostatic discharge (ESD). Electrostatic control precautions are required when installing, testing, servicing or repairing the assembly. Component damage may result if ESD control procedures are not followed. If you are not familiar with electrostatic control procedures, refer to the applicable ESD protection handbooks and guidelines.
	A drive that is incorrectly applied or installed can lead to component damage or reduction in product lifetime. Wiring or application errors such as undersizing the motor, supplying an incorrect or inadequate AC supply, or excessive ambient temperatures may result in system malfunction.

Warnings

Due to technical requirements products may contain dangerous substances. For information on the types in question please contact your nearest Infineon Technologies office.

Except as otherwise explicitly approved by Infineon Technologies in a written document signed by authorized representatives of Infineon Technologies, Infineon Technologies' products may not be used in any applications where a failure of the product or any consequences of the use thereof can reasonably be expected to result in personal injury.

Table of contents

About this document	1
Important Notice	2
Safety precautions	3
Warnings	3
Table of contents	4
1 Evaluation board introduction	5
1.1 Concept of the evaluation board	5
1.2 Key features	5
1.3 Application diagram of BLDC motor control.....	6
2 Evaluation board description	7
2.1 Interconnects	7
2.2 Jumper settings.....	8
2.3 Test points	9
2.4 Non – populated components	10
3 Getting started	11
3.1 Target applications	11
3.2 Evaluation setups.....	11
3.2.1 Getting started: TLE9140EQW driven by TLE987x.....	11
3.2.2 Getting started: TLE9140EQW driven by config wizard with a pulse generator	12
4 Start your evaluation	14
5 Revision history	15

1 Evaluation board introduction

1.1 Concept of the evaluation board

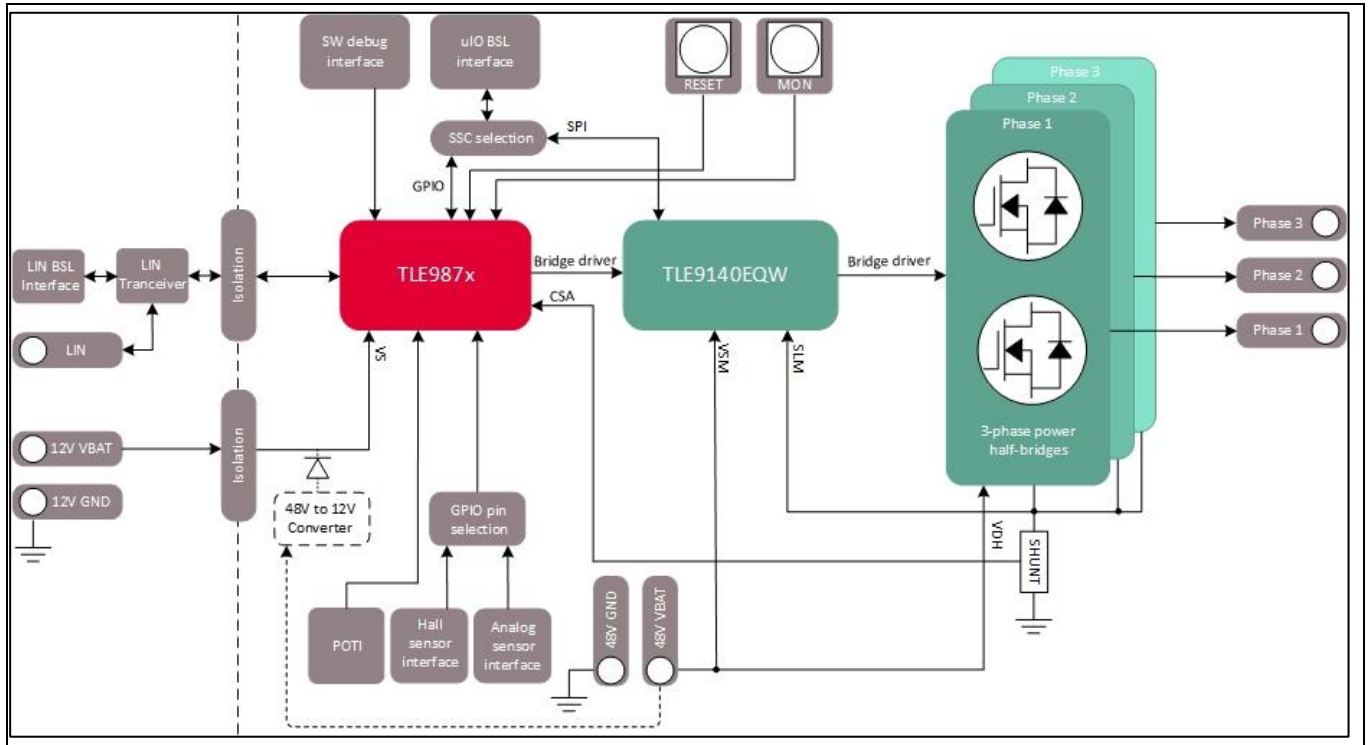

Figure 2 Concept of the evaluation board

This evaluation board can be used to evaluate MOTIX™ 48 V gate driver TLE9140EQW in two scenarios:

1. MOTIX™ 48 V gate driver TLE9140EQW controlled by MOTIX™ MCU device TLE987x.
2. Evaluate MOTIX™ 48 V gate driver TLE9140EQW with Config wizard in Infineon toolbox

It contains the TLE9140EQW, TLE987x and their typical application circuits including three half - bridges to drive a BLDC motor. The jumper X35 provide the possibilities to either connect the TLE9140EQW to uIO-Stick or to TLE987x. All pins of the TLE9140EQW device and the TLE987x device are connected to pin headers for easy measurement.

The evaluation board is supplied by 12 V and 48 V / 24 V power supply via banana jacks. And the LIN communication works via banana jacks.

An SWD interface is available for J - linker. There are two battery LEDs (12 V and 48 V) to indicate that the board is supplied correctly.

Note: 12 V GND is not connected to 48 V GND on the board due to the required isolation for 12 V system and 48 V system. Therefore, they must be connected externally in order to make the board operate properly.

1.2 Key features

The evaluation board has the following features:

- The TLE9140EQW can be controlled by the on board MOTIX™ MUC device or uIO-Stick (config wizard) with additional inputs signals.

Evaluation Board

Motor Control Shield introduction

- Drive 24 V / 48 V DC or BLDC motors (48 V supply can be replaced by 24 V supply to drive the applications in 24 V domain)
- High voltage capability: robustness up to 110 V
- Capable of high frequency PWM, e.g. 20 kHz
- Adjustable charge and discharge currents for optimized EMC performance
- High voltage compatible inputs
- Active LS freewheeling during VSM overvoltage
- SPI communication
- Protections and diagnostics e.g. against overtemperature, overcurrent, undervoltage, timeout watchdog and off – state diagnostic

1.3 Application diagram of BLDC motor control

As a starting point for the evaluation board, the application block diagram shown in Figure 3 was used. All input pins of TLE9140EQW are connected to the outputs of the power stage in the TLE987x device. The SPI ports are connected to the GPIO pins of the TLE987x device.

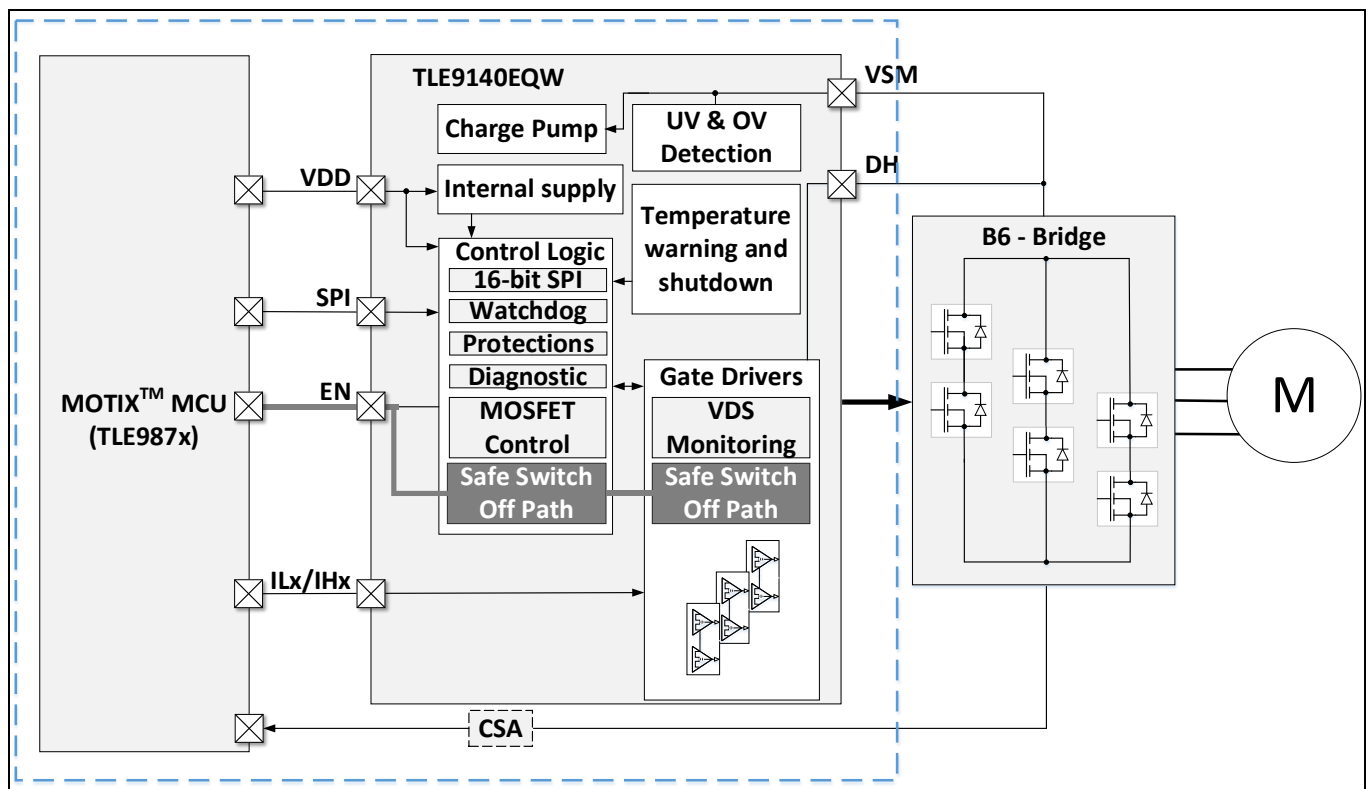

Figure 3 Application diagram of BLDC motor control with the evaluation board

Evaluation board description

2 Evaluation board description

For the purpose of evaluation for motor control design, discrete components are populated on board. They can be adapted to the dedicated motor control applications.

Figure 4 and Figure 5 show the interconnects, jumper settings, test points and the non-populated components.

2.1 Interconnects

In Figure 4 the interconnects of the evaluation board are shown.

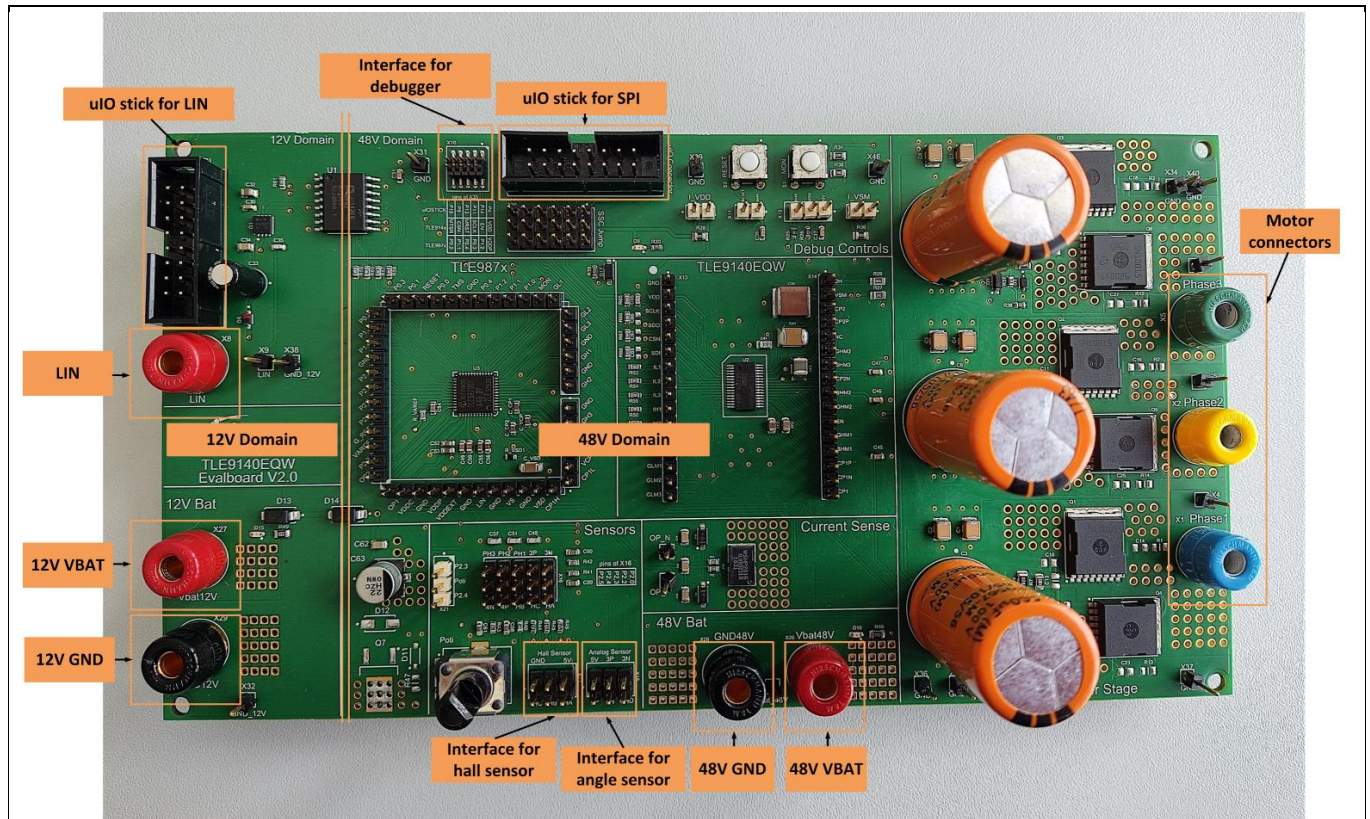

Figure 4 Interconnects of the 48 V MOTIX™ gate driver TLE9140EQW evaluation board

Power supply

The X26 and X28 are connectors for 48 V / 24 V GND and battery.
The X27 and X29 are connectors for 12 V GND and battery.

Motor connectors

The X26 and X28 are connectors for 48 V / 24 V GND and battery.

Hall sensor interface

The X23 is the interface of hall sensor as shown in the following table.

GND	n.c.	5V
HC	HB	HA

Angle sensor interface

The X15 is the interface of analog angle sensor as shown in the following table.

5V	3P	3N
4P	4N	GND

LIN connector and the uIO-Stick interface for LIN

Evaluation Board

Evaluation board description

The X8 is the LIN connector.

The X25 is intended to connect additional hardware for LIN communication.

2 (12 V GND)	4	6 (12 V VBAT)	8	10	12	14	16
1	3	5 (BUS)	7	9	11	13	15

Jumpers to select different use cases

The X35 can be used to select different use cases. For the use case “MOTIX™ MUC + TLE9140EQW” the last two rows (TLE9140EQW and TLE987x) should be connected via jumpers. For the use case “Evaluate TLE9140EQW with config wizard” the first two rows (uIO-Stick and TLE9140EQW) should be connected via jumpers.

uIO-Stick	P15	P9	P13	P11	P14	P4
TLE9140EQW	MTSR	CSN	MRST	SCLK	EN	VDD
TLE987x	P0.2	P1.1	P0.4	P0.3	P1.2	VDDP

Interface for debugger

The debugger (J-link) can be connected to X10 to debug the code.

2(SWDIO)	4(SWCLK)	6	8	10(RESET)
1(5V)	3(GND)	5(GND)	7	9(GND)

2.2 Jumper settings

The following table summarize the flexible configurations provided by jumpers:

X11	Enable or disable RESET button
X12	Enable or disable MON button
X16	Select the applications configurations with hall sensor or angle sensor
X21	Enable or disable potentiometer
X35	Select TLE987X or uIO-Stick as the master of SSC

For this board, P2.0, P2.2, P2.3, P2.4 and P2.5 in X16 can be used for different application configurations. PHx means phase voltage from corresponding BEMF. Hx means connector for hall sensor. 4N and 4P pins are the connectors for angle sensor. The definition of pins is described in the following table.

PH3	PH2	PH1	3P	3N
P2.5	P2.4	P2.3	P2.2	P2.0
4N	4P	HB	HC	HA

Evaluation Board

Evaluation board description

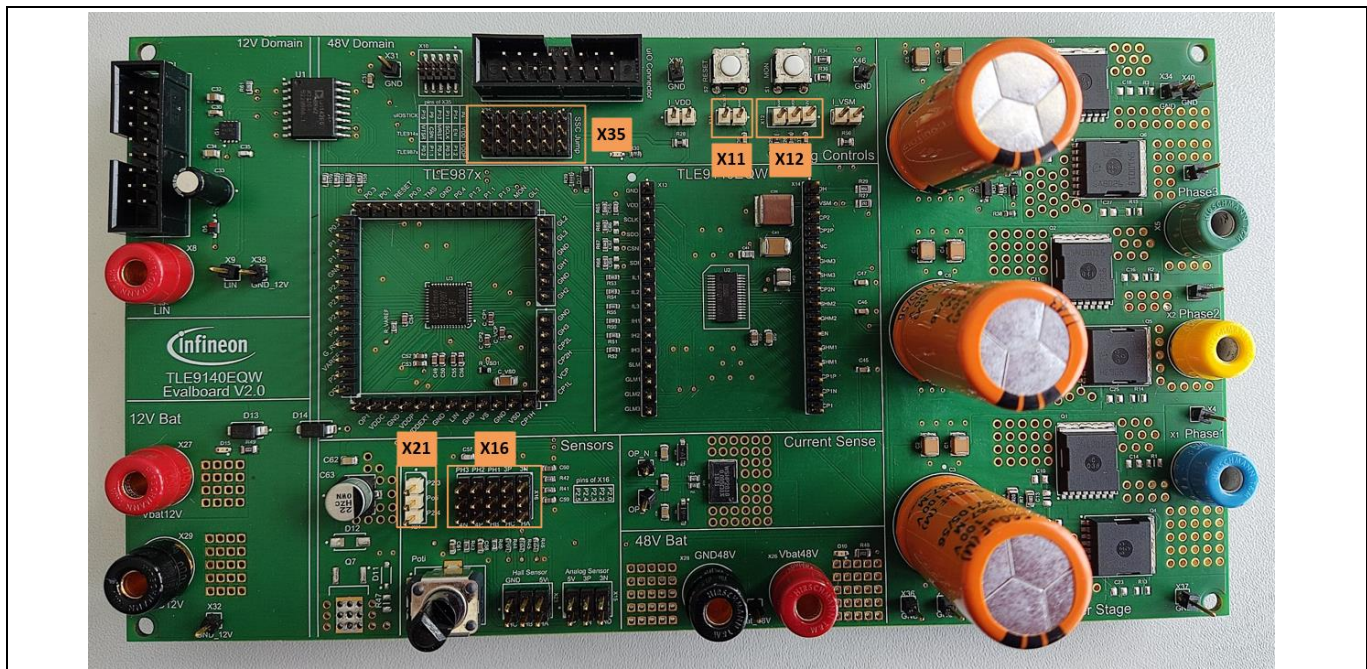

Figure 5 Jumpers on the evaluation board

2.3 Test points

The TLE9140EQW is used to drive the 3-phase half-bridges. All pins of the TLE9140EQW and TLE987X can be tested via the headers. The test points for 3-phases are available on board for easy measurement.

Test points OP_P and OP_N is used to measurement the voltage drops across the shunt resistance.

Test points I_VDD and I_VSM are used to measure the voltage drop across the 5 mΩ resistance in the VDD and 48 V supply line. The current consumption and the power consumption can be calculated based on the measurement result. In addition, many test points of 48 V supply, 48 V GND and 12 V supply are available on board for measurement.

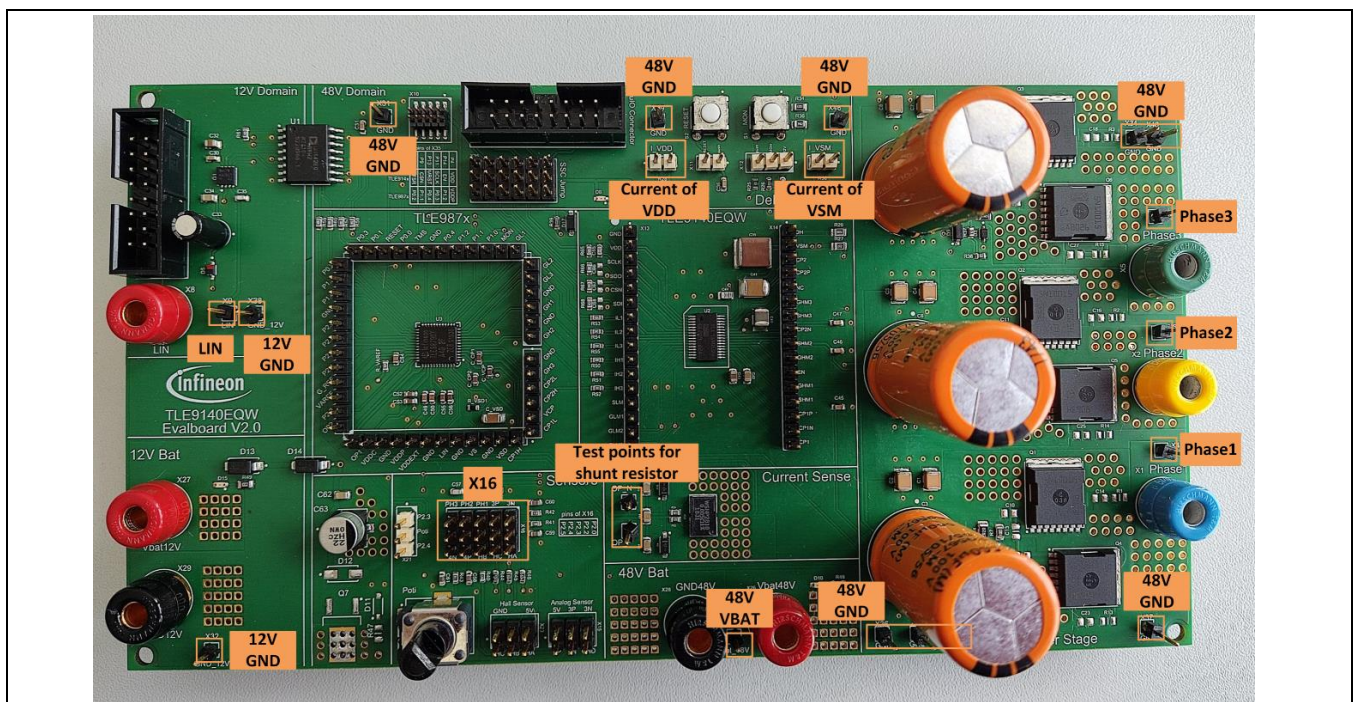

Figure 6 Test points on board

2.4 Non – populated components

This evaluation board offers two different supply concepts:

1. Use two diodes (D13 and D14) to implement the voltage isolation between 12 V domain and 48 V domain.
2. Use a source follower (Q7, C62, C63, R47, D11) to generate 12 V supply from 48 V battery.

The components for the concept with diodes are populated on board. The solder places for the concept with source follower are available. But the components are not populated. Additional components need to be soldered on the board to evaluate the board with the source follower.

TLE9140EQW has a current source gate driver. With the sequencer different currents can be selected for charging and discharging phases. The EMC performance can be improved without snubbers, gate-drain capacitance and gate-source capacitance. In case those components are preferred, the soldering places are available on the evaluation board.

Values for these optional components have to be determined depending on application conditions.

Q7	N-channel MOSFET
D12	Anti-reverse diode
D11	Zener diode to control Q7 with R47
R47	Resistor to control Q7 with D11
R1	Resistance snubber high-side MOSFET phase 1
C14	Capacitor snubber high-side MOSFET phase 1
C10	Gate-drain capacitor high-side MOSFET phase 1
C13	Gate-source capacitor high-side MOSFET phase 1
R13	Resistance snubber low-side MOSFET phase 1
C23	Capacitor snubber low-side MOSFET phase 1
C19	Gate-drain capacitor low-side MOSFET phase 1
C22	Gate-source capacitor low-side MOSFET phase 1
R2	Resistance snubber high-side MOSFET phase 2
C16	Capacitor snubber high-side MOSFET phase 2
C11	Gate-drain capacitor high-side MOSFET phase 2
C15	Gate-source capacitor high-side MOSFET phase 2
R14	Resistance snubber low-side MOSFET phase 2
C25	Capacitor snubber low-side MOSFET phase 2
C20	Gate-drain capacitor low-side MOSFET phase 2
C24	Gate-source capacitor low-side MOSFET phase 2
R3	Resistance snubber high-side MOSFET phase 3
C18	Capacitor snubber high-side MOSFET phase 3
C12	Gate-drain capacitor high-side MOSFET phase 3
C17	Gate-source capacitor high-side MOSFET phase 3
R15	Resistance snubber low-side MOSFET phase 3
C27	Capacitor snubber low-side MOSFET phase 3
C21	Gate-drain capacitor low-side MOSFET phase 3
C26	Gate-source capacitor low-side MOSFET phase 3

3 Getting started

3.1 Target applications

The target application of TLE9140EQW device is 48 V / 24 V DC and BLDC motor control. In the evaluation board the TLE9140EQW with required external components are available to support the evaluation of the device itself and the applications.

3.2 Evaluation setups

Two setups can be used to evaluate the TLE9140EQW device with the evaluation board. Example code is available for the setup “TLE9140EQW + TLE987x” (refer to the [TLE987x-eSL-Demo-TLE9140](#)) to support the evaluation. The config wizard can be used to have an easy evaluation for the setup “TLE9140EQW + uIO-Stick + input generator” (refer to the [Config Wizard for MOTIX™ BLDC Motor Gate Driver ICs](#)).

3.2.1 Getting started: TLE9140EQW driven by TLE987x

The getting started steps are based on an application software example provided in the delivery package, named TLE987x FOC sensorless example with TLE9140. This application example integrates the relevant software components of the Motor Control Demo for TLE9140EQW and the low level driver to run on the evaluation board with TLE9140EQW and TLE987x in a Keil® μ Vision® 5 software project. This software example is designed to drive a motor in two configurable control modes:

- Sensorless FOC mode
- V to F (voltage to frequency) mode

Hardware setup:

- A 48 V bipolar (4Q) power supply with adjustable output voltage that is capable to backsupply (in generator mode) and to deliver a current sufficient for turning the designed motor
- The evaluation board with TLE9140EQW and TLE987x connected to the power supply and connected to the PC via XMC Link - isolated debug probe based on the Segger J-Link interface.
- Evalboard V2.0 with TLE987x
- Specific hardware settings:
 - Jumpers X35 must be set for SPI communication between TLE987x and TLE9140EQW and to provide VDD (digital supply) of TLE9140EQW
 - Jumper X12 (MON of TLE987x) must be connected to the 12 V on Evalboard V2.0
 - The ground lines of 12 V and 48 V need to be connected externally

Software preparation:

For the evaluation of the TLE987x-eSL-Demo-TLE9140 Motor Control Library using the demo software example, the following software tool chain in MS Windows is required:

- Arm® Keil® μ Vision® 5, an integrated development environment (IDE)
- Infineon Embedded Power SDK (LLD) integrated in Keil® μ Vision® 5
- Segger J-Link Driver
- Infineon Config Wizard installed in Infineon Toolbox
- Micro Inspector Pro installed in Infineon Toolbox

Getting started steps:

- Load the provided application software example project FOC.uvprojx in Keil® μ Vision® 5

Getting started

- Choose the corresponding HW target device in Keil® µVision® 5
- Configure the motor parameters in Config Wizard
- Build the Keil® µVision® 5 project
Expected result: compiled successfully without any error or warning
- In Keil® µVision® 5, configure the connection to the target device to use the XMC Link - Isolated Debug Probe based on the Segger J-Link
- In Keil® µVision® 5, download the compiled code to the target flash memory
- Launch Micro Inspector Pro from Infineon Toolbox
- Load the workspace file "microInspector.wsp" provided in the corresponding "microinspector" folder in the example project
- Run the Micro Inspector project and take the control on the software execution:
 - Switch "Enable power stage" on
 - Switch "Enable control" on
 - Set a reference motor speed from the cursorExpected result: The motor starts turning

More details are described in the document "Motor Control Demo for TLE9140EQW with TLE987x".

3.2.2 Getting started: TLE9140EQW driven by config wizard with a pulse generator

In this setup the uIO-Stick is the interface between the PC and the TLE9140EQW evaluation board. It is controlled by the PC software and emulates the SPI communication as shown in Figure 7.

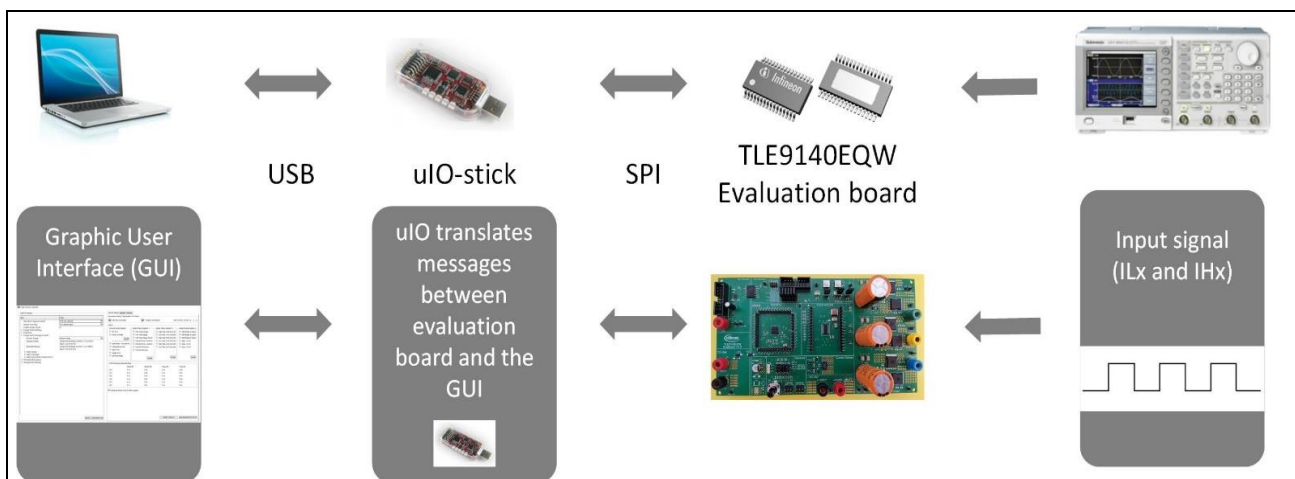

Figure 7 TLE9140EQW driven by config wizard with a pulse generator

Hardware setup:

- A 48 V bipolar (4Q) power supply with adjustable output voltage that is capable to backsupply (in generator mode) and to deliver a current sufficient for turning the designed motor
- The evaluation board with TLE9140EQW connected to the power supply and connected to the PC via uIO-Stick.
- Evalboard V2.0 with TLE9140EQW
- Specific hardware settings:
 - Jumpers X35 must be set for SPI communication between uIO-Stick and TLE9140EQW and to provide VDD (digital supply) of TLE9140EQW

Getting started

- Inputs pins IHx and ILx are connected the output of the pulse generator

Software preparation:

- Install Config Wizard for MOTIX™ BLDC Motor Gate Driver ICs

Getting started steps:

- Set the jumper for the test mode: SPI connection between TLE9140EQW and the uIO-Stick
- Connect the pulse generator to the inputs of the TLE9140EQW device
- Connect the motor or the load
- Connect the uIO-Stick to the TLE9140EQW evaluation board and to the PC
- Connect the 48 V or 24 V power supply
- Turn on the 48 V or 24 V power supply
- Start the TLE9140EQW Config Wizard
- To operate the half-bridges:
 - Enable the charge pump
 - Provide the proper input signals with the pulse generator
 - Configure the MOSFET driver timings and currents
 - Enable the gate driver
 - Update the configuration

For more details please click the question mark in Config Wizard for MOTIX™ BLDC Motor Gate Driver ICs to download the document “Config Wizard Tool for MOTIX™ BLDC Motor Gate Driver IC for TLE9140EQW”.

4 Start your evaluation

Now you have the basic setup to investigate the device. You can make the evaluation with the evaluation board in different application conditions such as different supply voltages, PWM frequency, duty cycle, temperatures or with different motor loads.

In case you have further questioning for the setup please contact your IFX sales representative or the IFX [technical support](#).

5 Revision history

Revision number	Date of release	Description of changes
Rev. 4.0	2023-12-13	Correct typos (refer to evaluation board v2.0)
Rev. 3.0	2023-08-01	Add config wizard chapter (refer to evaluation board v2.0)
Rev. 2.0	2020-08-01	Refer to evaluation board v2.0
Rev. 1.0	2019-11-01	Initial release (refer to evaluation board v1.0)

X-ON Electronics

Largest Supplier of Electrical and Electronic Components

Click to view similar products for [Power Management IC Development Tools](#) category:

Click to view products by [Infineon](#) manufacturer:

Other Similar products are found below :

[EVB-EP5348UI](#) [BQ25010EVM](#) [ISL80019AEVAL1Z](#) [ISLUSBI2CKIT1Z](#) [ISL8002AEVAL1Z](#) [ISL91108IIA-EVZ](#) [MAX8556EVKIT](#)
[MAX15005AEVKIT+](#) [ISL28022EVKIT1Z](#) [STEVAL-ISA008V1](#) [DRI0043](#) [KITPF8100FRDMEVM](#) [EVB-EN6337QA](#)
[SAMPLEBOXILD8150TOBO1](#) [MAX18066EVKIT#](#) [AP62300WU-EVM](#) [KITA2GTC387MOTORCTRTOBO1](#) [AEK-MOT-TK200G1](#)
[EVLONE65W](#) [STEVAL-ILH006V1](#) [STEVAL-IPE008V2](#) [STEVAL-IPP001V2](#) [STEVAL-ISA013V1](#) [STEVAL-ISA067V1](#) [STEVAL-](#)
[ISQ002V1](#) [TPS2306EVM-001](#) [TPS2330EVM-185](#) [TPS40001EVM-001](#) [SECO-HVDCDC1362-15W-GEVB](#) [BTS7030-2EPA](#)
[LT8638SJV#WPBF](#) [LTC3308AIV#WTRPBF](#) [TLT807B0EPV](#) [BTS71033-6ESA](#) [EV13N91A](#) [EASYPIC V8 OVER USB-C](#) [EV55W64A](#)
[CLICKER 4 FOR STM32F4](#) [EASYMX PRO V7A FOR STM32](#) [CLICKER 4 FOR PIC18F](#) [Si8285_86v2-KIT](#) [PAC52700EVK1](#) [NCP-](#)
[NCV51752D2PAK3LGEVB](#) [ISL81807EVAL1Z](#) [AP33772S-EVB](#) [EVALM7HVIGBTFCINV4TOBO1](#) [903-0300-000](#) [902-0173-000](#) [903-](#)
[0301-000](#) [ROA1286023/1](#)