

規格承認書

PECIFICATION FOR APPROVAL

客戶

CUSTOMER : 通用型规格书

項目

ITEM : 驻极体电容咪头 (ECM) 全指向

型號

TYPE : GMBO3015GSB-39~48DB

描述

DESCRIPTION : $\phi 3.0 \times 1.5 \text{ MM}$ 焊点 1033 范围-39~-48+/-3 dB $\leq 2.2\text{K}\Omega$ S/N: $\geq 60 \text{ dBA}$

客戶料號

CUSTOMER NO. :

規格書號

SPECIFICATION NO.: 会议、头戴、直播产品专用

版本

EDITION NO. : V1.0

日期

DATE : 2023-2-15

客戶承認

CUSTOMER CONFIRM AND SIGN

檢查 TESTED BY	審核 CHECKED BY	承認 APPROVED BY

東莞市贏海電子有限公司

DONGUAN INGHAI ELECTRONICS CO.,LTD

製作 ISSUED BY	審查 CHECKED BY	確認 APPROVED BY
周明	李勇	

地址：廣東省東莞市長安鎮新崗路 43 號華茂大廈 15 樓

電話 / TEL: 0769-83060958 傳真 / FAX: 0769-81608993

網址: HTTP://WWW.INGHAI.COM

●MODEL:

●CUSTOMER:

1. Electrical characteristics:

Directivity	Omnidirectional
Pb contination Requirement	Lead free
Charging type	Back plate
Sensitivity	-39~-48±3dB (0dB=1V/Pa, 1KHz)
Output impedance	Low impedance
Standard operating voltage	2V
Operating voltage range	1V-10V
Current consumption	less than 500 μ A
Voltage deduction characteristic	Within 3dB at 1.5V
S/N Ratio	More than 60dB (SPL=1Pa, 1KHz, A-weighting)

2. Frequency Response and Schematic Diagram:

2.1 Typical Frequency Response Curve:

FrequencyResponse

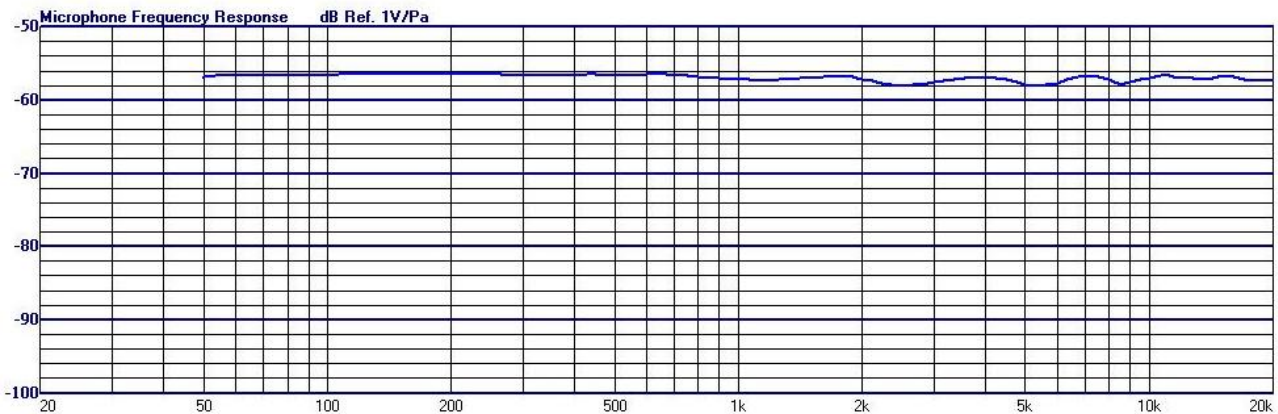

2.2 Schematic Diagram:

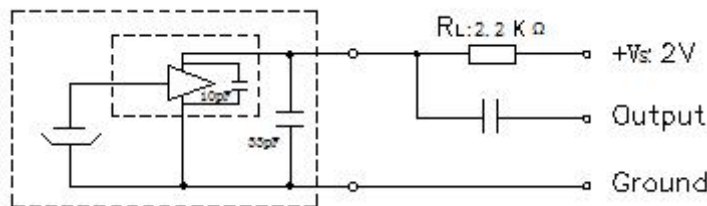

Version: A

Effective Date: 07/02/01

WIE007-01

2/7

3. Mechanical characteristics:

3.1 Weight:Less than 0.3g

3.2 Dimension:

Unit:mm

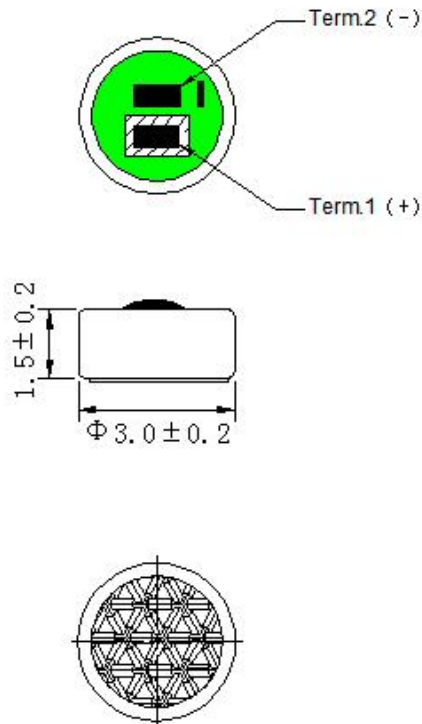

4. Soldering Condition

- 4.1 The soldering copper of a small type of 13~20W shall be applied.
- 4.2 The temperature of the working surface of the soldering copper shall be below 320°C.
- 4.3 ECM shall be soldered fixed on the metal block (heat sink), which has the higher radiation effects said heat sink shall contact with of ECM.
- 4.4 The soldering time for each terminal shall be 1~2 sec.
- 4.5 The pinhole after soldering shall be avoided.
- 4.6 ECM may easily destroyed by the static electricity and the countermeasure for eliminating the static electricity (the ground for soldering copper, for worktable and for human body) shall be executed

Version: A

Effective Date: 07/02/01

WIE007-01

3/7

5.PACKAGING:

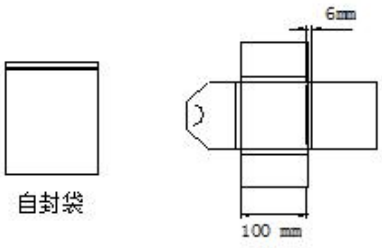
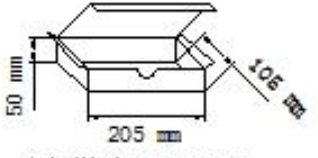
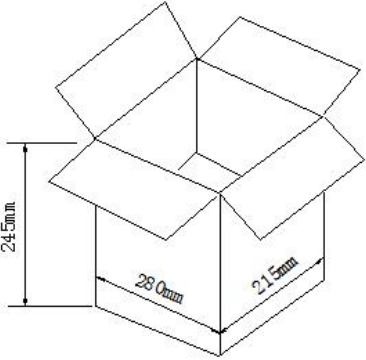
<p>小包装</p>	<p>SMALL PACKET 100mm*100mm*6mm 200PCS</p>	 <p>自封袋 小包装盒 (200只)</p>
<p>中包装</p>	<p>MID PACKET: 205mm*105mm*50mm 2800PCS/MID PACKET</p>	 <p>中包装盒 (2800只)</p>
<p>大包装</p>	<p>PAPER CASE: 280mm*215mm*245mm 28000PCS/PAPER CASE</p>	 <p>大包装箱 (28000只)</p>

Version: A

Effective Date: 07/02/01

WIE007-01

4/7

6. TEST SETUP DRAWING

Standard Frequency Response Test

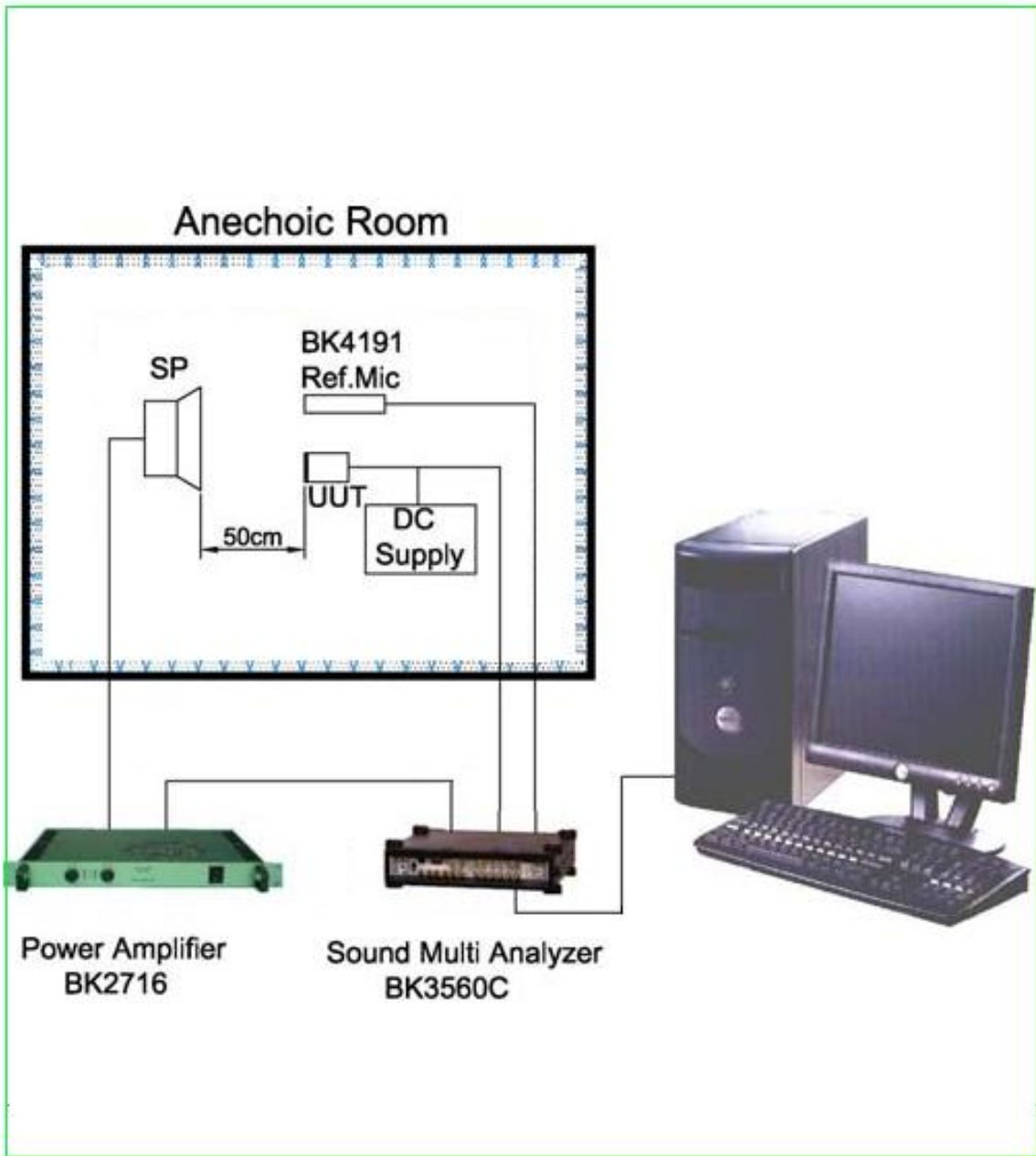

Version: A

Effective Date: 07/02/01

WIE007-01

5/7

7. Reliability test:

Item	Test condition	Evaluation
1	High temperature Test	The part shall be capable of with- standing a storage temperature of +70 °C for 200 hours.
2	Low temperature Test	The part shall be capable of with- standing a storage temperature of -20 °C for 200 hours.
3	Temperature cycle test	The part shall be subjected to 5 cycle. One cycle shall consist of (+70 °C ,30min → Room temp(+20°C), 10min→-20°C30min →Room temp(+20°C), 10min)
4	Humidity Test	The part shall be capable of with- standing a storage of humidity of 90 ~ 95% at the +40°C for 200 hours.
5	Drop Test	The microphone unit without package must be subjected to each 3 drops at three axes from the height of 1 meter to 20 mm thick hardwood board.
6	Vibration Test	The microphone unit must be subjected to each 2 hours vibrations at three axes 2mm dynamic range, 10~50Hz/minute.
7	Soldering Heat Resistance	Soldering iron of +330 ± 5 °C should be placed on the terminal for 2±0.5 seconds.
After the test the ECM unit shall meet the requirement of no more than ±3dB variation from initial sensitivity after 2 hours recovering.		

8.Drawing

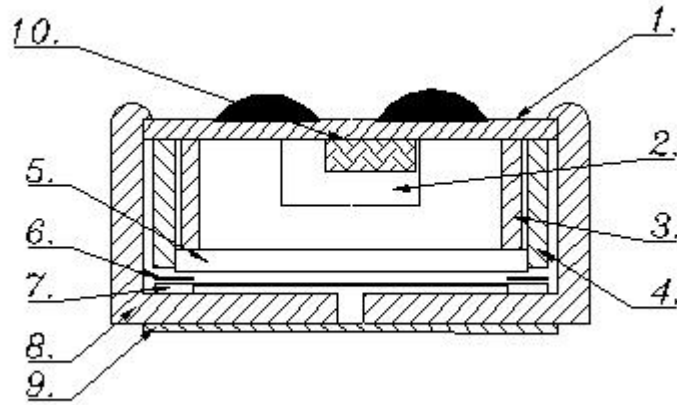

1	PCB	7	背极膜
2	FET	8	外壳
3	连接环	9	防水网
4	塑环	10	电容
5	背极板	11	
6	垫片	12	

X-ON Electronics

Largest Supplier of Electrical and Electronic Components

Click to view similar products for [Microphones](#) category:

Click to view products by [INGHAI](#) manufacturer:

Other Similar products are found below :

[BCM4013OLFC-42-JST-ZHR-2](#) [FG-23329-P142](#) [SPM04C-38/1186-T/R](#) [B4013AM423-092](#) [KECG2242CBL-G01](#) [KEAG4544PF-K](#)
[KECG1544WB-G01](#) [KEAG6536PF-D](#) [GMDO9445CST-45DB](#) [GMDU9750ASN-36B-54DB](#) [KECG2234WBL-30L](#) [B4013AM423-103](#)
[CMR-2747PB-A](#) [GMBU4015CSC-50DB](#) [GMDU9750ASN-36B-52DB](#) [GMBU16065CSC-02-43DB](#) [GMBU14065CSC-44DB](#)
[GMBU6027CSC-03-52DB](#) [GMDU9750ASN-36B-48DB](#) [GMDU9750CSD-02-47DB](#) [GMBO3015GSB-45DB](#) [GMDO9445CST-43DB](#)
[GMDU9750ASN-36B-46DB](#) [GMDU9750ASN-36B-50DB](#) [GMDU9750CSD-02-43DB](#) [GMI6025A3-912-1.2R](#) [GMBU6027CSC-03-50DB](#)
[GMI6025P3-915-1.8R](#) [GMBU16065CSC-01-43DB](#) [GMBU14065CSC-46DB](#) [GMBU16065CSC-02-45DB](#) [GMI6025P3-912-1.2R](#)
[GMBU16065CSC-02-41DB](#) [GMBU4015CSC-52DB](#) [GMI6025A6-911-1.0R](#) [GMBU4015CSC-54DB](#) [GMDU9750CSD-02-45DB](#)
[GMBU16065CSC-01-45DB](#) [GMBU6027CSC-03-54DB](#) [GMDO9445CST-47DB](#) [GMBU14065CSC-42DB](#) [GMDU9750ASN-36B-44DB](#)
[GMBU16065CSC-01-41DB](#) [BCM9745-44](#) [BCM9765](#) [LD-MC-0905P](#) [LD-MC-9765](#) [EM-4015-BC](#) [EM-4530-C](#) [EM-6022S](#)