

規格承認書

PECIFICATION FOR APPROVAL

客戶
CUSTOMER : 立創
項目
ITEM : 驻极体咪头 (ECM)
型號
TYPE : GMI9745P-64DB
描述
DESCRIPTION : $\phi 9.7 \times H4.5\text{mm}$ 插针 -64dB $\leq 2.2\text{K}\Omega$ $\leq 0.5\text{mA}$ S/N: ≥ 58 dBA
客戶料號
CUSTOMER NO. :
規格書號
SPECIFICATION NO.:
版本
EDITION NO. : V1.0
日期
DATE : 2019-12-27

客戶承認

CUSTOMER CONFIRM AND SIGN

| 檢查 TESTED BY | 審核 CHECKED BY | 承認 APPROVED BY |
|-----------------|------------------|-------------------|
| | | |

東莞市贏海電子有限公司

DONGUAN INGHAİ ELECTRONICS CO.,LTD

| 製作 ISSUED BY | 審查 CHECKED BY | 確認 APPROVED BY |
|-----------------|------------------|-------------------|
| 周明 | 刘承成 | |

地址：廣東省東莞市長安鎮廈邊元灶頭工業區 16-6 號
電話 / TEL: 0769-83060958 傳真 / FAX: 0769-81608993
網址: HTTP://WWW.INGHAİ.COM

A. SCOPE

This specification applies electret condenser microphone, GMI9745P-64DB

B. SPECIFICATION

■ Test condition: $RL=2.2K\Omega$ $VS=4.5V$ $TEMP=25^{\circ}C\pm 2^{\circ}C$ Related humidity= $65\pm 5\%$

| No. | Item | Symbol | Unit | Specification | Condition |
|-----|----------------------------|---------------|------------|-----------------|------------------------------------|
| 1 | Directivity | | | Omnidirectional | |
| 2 | Sensitivity | S | dB | -64±3 | f=1KHz, 1Pa 0dB=1V/ubar |
| 3 | Standard operating voltage | Vs | V | 4.5 | |
| 4 | Output impedance | Zout | K Ω | ≤2.2 | f=1KHz, 1Pa |
| 5 | Frequency | | Hz | 100-10000 | |
| 6 | Max operating voltage | | V . | 10 | |
| 7 | Sensitivity reduction | $\Delta S-Vs$ | dB | -3 | f=1KHz, 1Pa vs=4.5VDC to 3.0VDC |
| 8 | Max. current consumption | Idss | mA | ≤0.5 | |
| 9 | Signal to noise ration | S/N | dBA | ≥58 | |
| 10 | Max. Sound Pressure Level | S.P.L | dB | 110 | |
| 11 | Operation temp. | | °C | -20 ~+70 | |
| 12 | Storage temp. | | °C | -40 ~+80 | |
| 13 | Dimension | | mm | ϕ 9.7x4.5 | See appearance drawing |
| 14 | Terminal | | | Terminal | See appearance drawing |

We use "Pascal(Pa)" indication of sensitivity as per the recommendation of I.E.C.(International Electro technical Commission)

The Sensitivity of "Pa" will increase 20dB comparing with "ubar" indication

Example: -60dB(0dB=1V/ubar) =-40dB(1V/Pa)

B. TYPICAL FREQUENCY RESPONSE CURVE

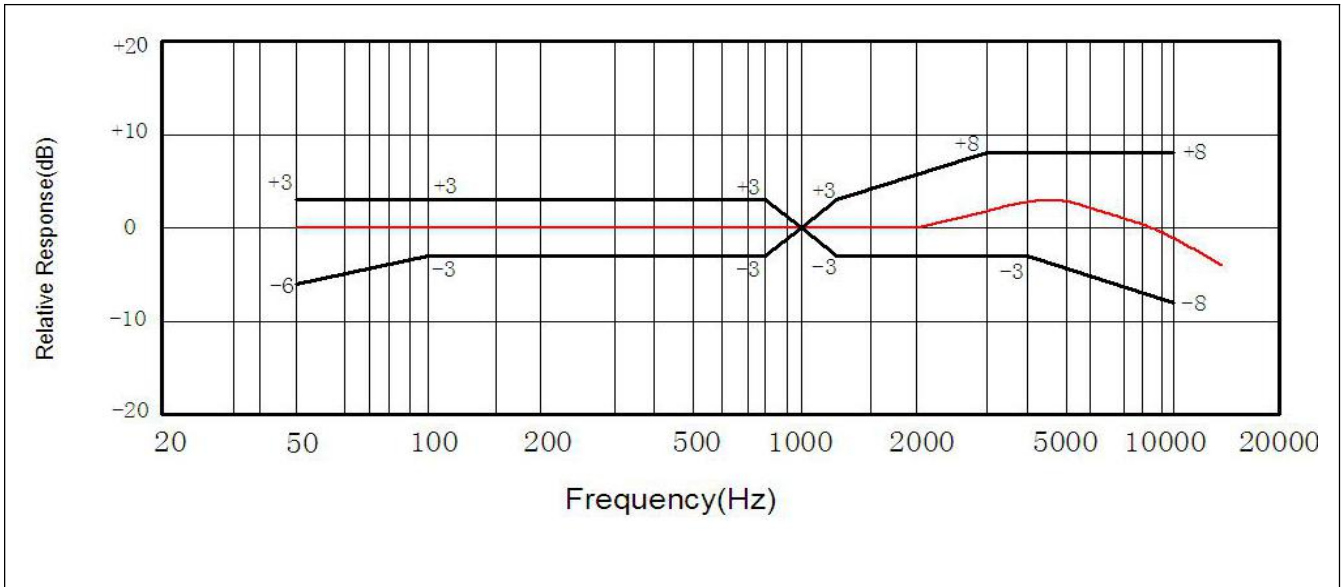

D. APPEARANCE DRAWING

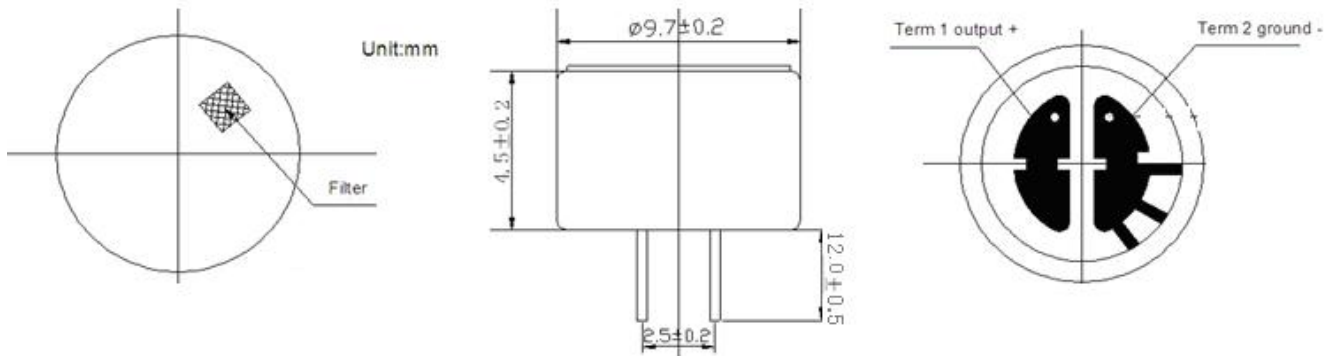

E. MEASUREMENT CIRCUIT

-

| F. 可靠性试验 Reliability Test | |
|--|---|
| <p>经过以下所有试验在 20℃的条件下放置 3 小时后,麦克风的灵敏度与试验前比较变化在 3dB 以内</p> <p>After any following tests, the sensitivity of the microphone to be within $\pm 3\text{dB}$ of initial sensitivity after 3hours of conditioning at 20℃</p> | |
| 5-1 振动试验 Vibration | 周波数 1/Frequency1:10Hz~55Hz 振幅/Amplitude:1.52mm 变化/Change of Frequency:1 octave/min 3 方向,各 2 小时/hours in each of 3 axes |
| 5-2 高温试验 Dry Heat | +80 \pm 5℃ for 96 hours |
| 5-3 低温试验 Dry Cold | -40 \pm 5℃ for 96 hours |
| 5-4 高温高湿试验 Damp Heat | 90%~95%RH, +60 \pm 5℃ for 96 hours |
| 5-5 温度循环试验 Temperature cycles | -20℃ \longleftrightarrow 25℃ \longleftrightarrow 70℃ (2h) (1h) (2h) (1h) (2h) \times 10 cycles |
| 5-6 跌落试验 Packing drop test | Height:1m 顺序:三个面各跌 10 次 Procedure:10 times from each of 3 axes |
| 5-7 温度冲击试验 Temperature impact test | -20℃ \longleftrightarrow 70℃ 30min 30s 30min \times 10 cycles |
| 5-8 静电冲击试验 Electrostatic shock test | 6000V(contact), 10000V(air) \times 10 axes |
| 备注 Note | |
| 6-1 工作温度范围 Operation Temperature | -20℃~70℃ |
| 6-2 储存温度范围 Storage Temperature | -40℃~80℃ |
| G. 焊接条件 | |
| Soldering Condition | |
| 7-1 焊接使用 90W 的烙铁。 The soldering copper of a type of 90W shall be applied | |
| 焊接条件 Soldering Condition. | |
| 7-2 电烙铁表面温度 320 \pm 10℃ The temperature of the working surface of the soldering copper shall be 320 \pm 10℃ | |
| 7-3 焊接时把麦克风嵌入散热能力强的金属块内。 ECM shall be soldered fixed on the metal block(heat sink)which has the higher radiation effects said heat sink Shall contact with of ECM. | |

7-4 焊接时间控制在 2~3 秒内。
time for each terminal shall be 2~3 sec.

7-5 焊接后不能出现针孔。
The pinhole after soldering shall be avoided.

7-6 静电容易破坏麦克风必须采取措施避免（电烙铁接地，戴静电环等。）
ECM may easily destroyed by the static electricity and the countermeasure for eliminating the static electricity (the ground for soldering copper, for worktable and for human body) shall be executed.

7-7 散热板形状 Shape of heat sink

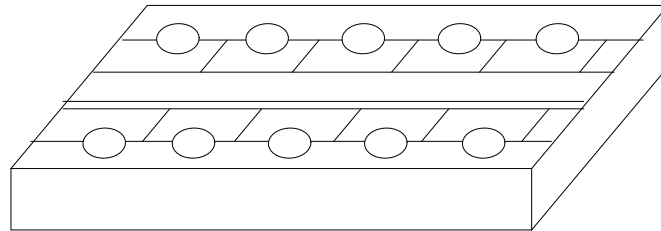

7-8 固定部孔形状 Shape of hole at fixed part

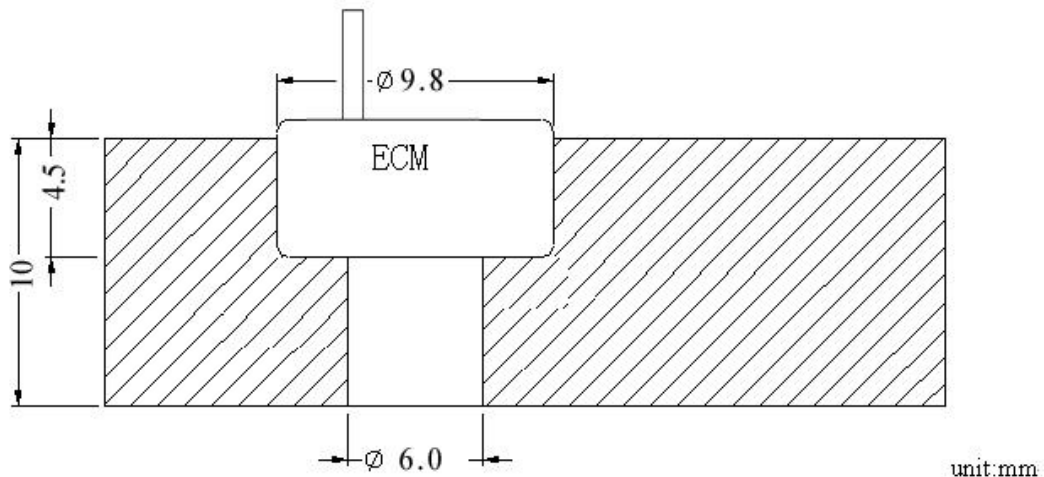

X-ON Electronics

Largest Supplier of Electrical and Electronic Components

Click to view similar products for [Microphones](#) category:

Click to view products by [INGHAI](#) manufacturer:

Other Similar products are found below :

[BCM4013OLFC-42-JST-ZHR-2](#) [TO38-30702-B20](#) [FG-23329-P142](#) [254-ECM6441-RO](#) [AOM-6742P-2-R](#) [SPM04C-38/1186-T/R](#) [POM-2244L-C33-R](#) [AOM-6545P-R](#) [ANM-5254L-R](#) [AOM-6738L-R](#) [AOM-6738P-R](#) [BCM4013OSBC-42 LF](#) [ANM-5254L-LW100-R](#) [AOM-4540P-R](#) [PUM-3046L-R](#) [TOM-1545L-R](#) [POM-2738L-LW100-R](#) [POM-2738P-C33-R](#) [POM-3542P-R](#) [POM-3535L-3-LW100-R](#) [POW-2742P-C3310-B-R](#) [AOM-6738L-LW100-R](#) [AOW-4544P-C3310-B-R](#) [POM-2735P-R](#) [POW-2742L-C3310-B-R](#) [PUM-5250L-C3310-R](#) [POM-5038P-C3310-R](#) [TOW-1242P-R](#) [POM-5046P-C3310-R](#) [TC-32348-000](#) [TC-32485-000](#) [BCM9745-44](#) [BCM9767P](#) [LD-MC-6035](#) [LD-MC-9765](#) [CMC-4015-40P](#) [PMO-6022SN-42UQ](#) [PMOF-6027WN-44KDQ](#) [PMO-4015PN-42KDQ](#) [CMC-6027-42L100](#) [PMO-6027P-40KDQ](#) [PMOF-6050S-44UQ](#) [PMO-4530PN-47UQ](#) [PMO-4015MN-42HXQ](#) [CMC-6036-40T](#) [CMC-4015-25T](#) [CMC-6027-24T](#) [PMOF-9767NP-46DQ](#) [PMOF-9745W-42UQ](#) [PMOF-9745P-39UQ](#)