

## MCB 1005-2012 H Series

# Specification

<b>Product Name</b>	<b>Chip Ferrite Bead</b>
<b>Series</b>	<b>MCB H Series</b>
<b>Size</b>	<b>EIAJ 1005-2012</b>



## Chip Ferrite Bead (MCB H Series) Engineering Spec.

### ■ FEATURES

- Monolithic inorganic material construction
- Closed magnetic circuit avoids crosstalk
- SMD Type & suitable for reflow and wave soldering
- Available in various sizes
- Excellent solderability and heat resistance
- High reliability
- With a sharp and frequency frequency impedance characteristics which can effectively filter high frequency noise without attenuating high frequency signal

### ■ APPLICATIONS

Filtering between analog and digital circuitry, clock generation circuitry, I/O interconnects, isolation between RF noisy circuits and logic devices susceptible to functional degradation, power supply filtering to prevent conducted RF energy from corrupting the power generation circuitry. Sharp impedance characteristics can effectively minimize attenuation, high frequency EMI prevention of LCD monitor, PDA, Computers, Computer peripherals, Cellular Equipment, Digital TV, Digital Cameras, Audio/Visual Equipment, DVD, Wireless Communication Devices, MP3.

### ■ SHAPES AND DIMENSIONS

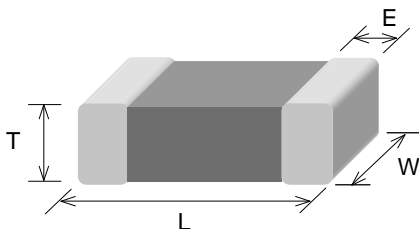

Unit: mm

TYPE	1005 (EIA 0402)	1608 (EIA 0603)	2012 (EIA 0805)
L	1.00±0.10	1.60±0.15	2.00±0.20
W	0.50±0.10	0.80±0.15	1.25±0.20
T	0.50±0.10	0.80±0.15	0.90±0.20
E	0.25±0.10	0.30±0.20	0.50±0.30

## ■ PART NUMBER CODE

MCB 1608 H 12 1 E B P  
 1      2      3      4      5      6      7      8

- 1 Series Name
- 2 Size Code: the first two digitals : length(mm), the last two digitals : width(mm)
- 3 Material Code
- 4 Impedance( $\Omega$ )  $\pm$  25% } (ex : 121=120 $\Omega$ )
- 5 Fixed Decimal Point
- 6 Rated Current Code

A=50mA	B=80mA	C=100mA	D=150mA	E=200mA	F=300mA
G=400mA	H=500mA	I=600mA	J=700mA	K=800mA	

- 7 Soldering : Green Parts: A— Soldering Lead-Free B— Lead-Free for whole chip
- 8 Packaging: P - Embossed paper tape, 7" reel.

## ■ PART NUMBER AND CHARACTERISTICS TABLE

Part No.	Impedance( $\Omega$ ) +/-25%	Test Freq. (MHz)	DCR( $\Omega$ ) (Max.)	Rated Current (mA)
MCB1005-H Series				
MCB1005H750FBP	75	100	0.40	300
MCB1608-H Series				
MCB1608H200HBP	20	100	0.25	500
MCB1608H750HBP	75	100	0.35	500
MCB1608H800HBP	80	100	0.35	500
MCB1608H121EBP	120	100	0.45	200
MCB1608H301EBP	300	100	0.45	200
MCB1608H601EBP	600	100	0.50	200
MCB1608H102EBP	1000	100	0.60	200
MCB2012-H Series				
MCB2012H121EBP	120	100	0.25	200
MCB2012H221EBP	220	100	0.25	200
MCB2012H301EBP	300	100	0.25	200
MCB2012H601EBP	600	100	0.35	200

<b>Test Instruments :</b>	<ul style="list-style-type: none"> <li>•Test Level : 250 mV</li> <li>•HP4291B RF IMPEDANCE / MATERIAL ANALYZER</li> <li>•HP4338A/B MILLIOHMMETER</li> <li>•Agilent 8720ES S-PARAMETER NETWORK ANALYZER</li> <li>•HP6632B SYSTEM DC POWER SUPPLY</li> </ul>
---------------------------	--

\*\* For special part number which is not shown in the above table, please refer to appendix.

## ■ TAPE AND REEL SPECIFICATIONS

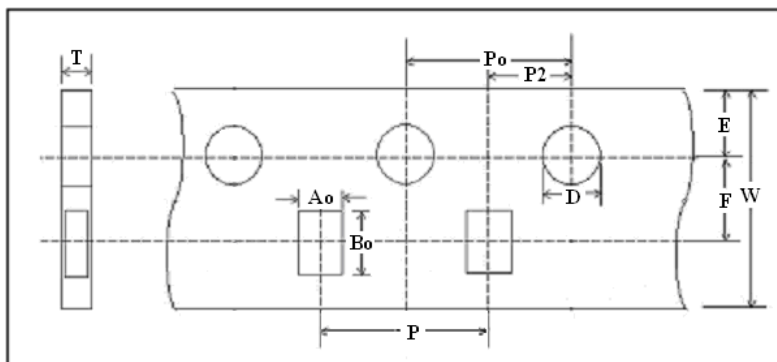

## ■ TAPING DIMENSIONS

Unit: mm

Size	2012	1608	1005
Symbol	PAPER	PAPER	PAPER
W	8.00±0.10	8.00±0.10	8.00±0.10
P	4.00±0.10	4.00±0.10	2.00±0.05
E	1.75±0.10	1.75±0.10	1.75±0.05
F	3.50±0.10	3.50±0.10	3.50±0.05
D	1.56±0.10	1.56±0.10	1.55±0.05
D1	NA	NA	NA
Po	4.00±0.10	4.00±0.10	4.00±0.10
Po10	40.0±0.20	NA	NA
P2	2.00±0.10	2.00±0.10	2.00±0.05
Ao	1.50±0.05	1.05±0.05	0.62±0.03
Bo	2.30±0.05	1.85±0.05	1.12±0.03
Ko(T)	0.95±0.05	0.95±0.05	0.60±0.03
t	NA	NA	NA

■ REEL DIMENSIONS

Unit: mm

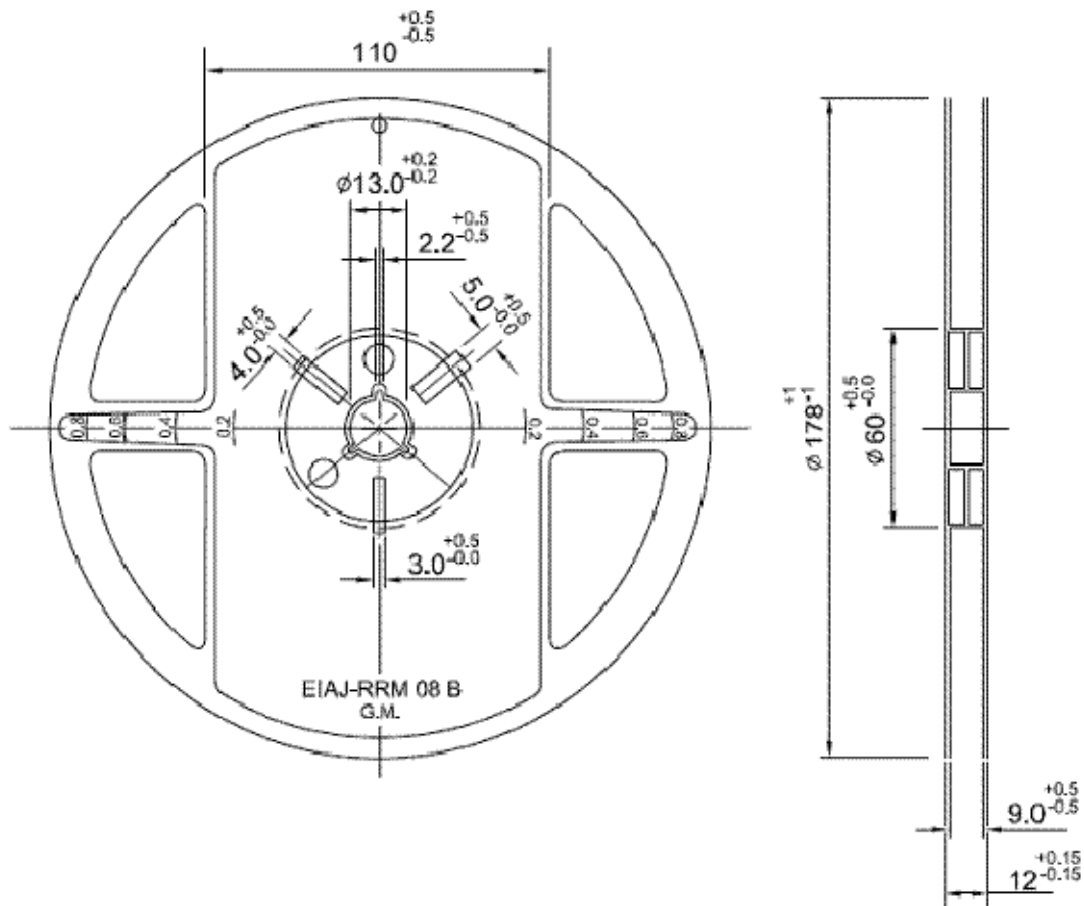

Reel Packaging Quantity				
PART SIZE (EIA SIZE)		<b>1005 (0402)</b>	<b>1608 (0603)</b>	<b>2012 (0805)</b>
7" REEL	Qty. (pcs)	10,000	4,000	4,000

**The Contents of a box :**

- 2012 (0805): 5 reels / inner box
- 1608 (0603): 5 reels / inner box
- 1005 (0402): 5 reels / inner box

■ **RECOMMENDED SOLDERING CONDITIONS**

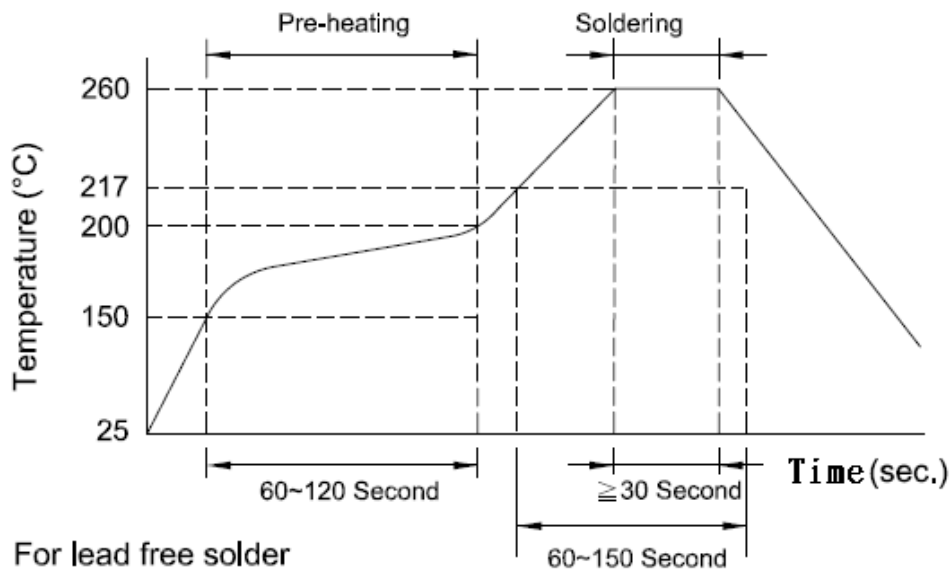

■ **LAND PATTERNS FOR REFLOW SOLDERING**

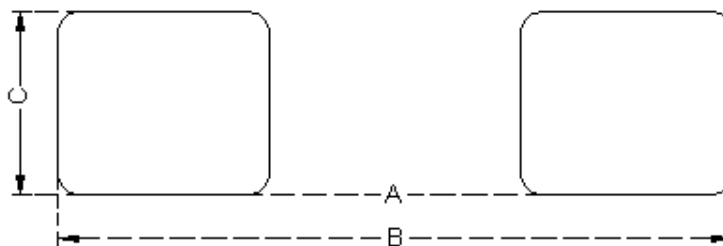

■ **SOLDER LAND INFORMATION**

Unit: mm (inches)

Size	A	B	C
1005	0.40 ~ 0.60 (0.015 ~ 0.023)	1.60 ~ 2.60 (0.063 ~ 0.102)	0.40 ~ 0.70 (0.016 ~ 0.027)
1608	0.50 ~ 0.70 (0.019 ~ 0.027)	2.10 ~ 3.10 (0.083 ~ 0.122)	0.65 ~ 0.95 (0.026 ~ 0.037)
2012	1.00 ~ 1.20 (0.039 ~ 0.047)	3.00 ~ 4.00 (0.118 ~ 0.157)	0.80 ~ 1.10 (0.031 ~ 0.043)

**■ RELIABILITY AND TEST CONDITION**

Test item	Test condition	Criteria
<b>Temperature Cycle</b>	a. Temperature : -40 ~ +85°C b. Cycle : 100 cycles c. Dwell time : 30minutes d. Measurement : at ambient temperature 24 hrs after test completion	a. No mechanical damage b. Impedance value should be within $\pm 20\%$ of the initial value
<b>Operational Life</b>	a. Temperature : 125°C $\pm 5^\circ\text{C}$ b. Test time : 1000 hrs c. Apply current : full rated current d. Measurement : at ambient temperature 24 hrs after test completion	a. No mechanical damage b. Impedance value should be within $\pm 20\%$ of the initial value
<b>Biased Humidity</b>	a. Temperature : 40°C $\pm 2^\circ\text{C}$ b. Humidity : 90 ~ 95 % RH c. Test time : 1000 hrs d. Apply current : full rated current e. Measurement : at ambient temperature 24 hrs after test completion	a. No mechanical damage b. Impedance value should be within $\pm 20\%$ of the initial value
<b>Resistance to Solder Heat</b>	a. Solder temperature : 260 $\pm 5^\circ\text{C}$ b. Flux : Rosin c. DIP time : 10 $\pm 1$ sec	a. More than 95 % of terminal electrode should be covered with new solder b. No mechanical damage c. Impedance value should be within $\pm 20\%$ of the initial value d.
<b>Adhesive Test</b>	a. Reflow temperature : 245°C It shall be Soldered on the substrate applying direction parallel to the substrate b. Apply force(F) : 5 N c. Test time : 10 sec	a. No mechanical damage b. Soldering the products on PCB after the pulling test force > 5 N
<b>Rated Current Test</b>	a. Apply current : full rated current / 5min	Temperature rise should be less than 25°C
<b>Steam Aging Test</b>	a. Temperature : 93°C b. Test time : 4 hrs(MCB1005) Others : 8 hrs c. Solder temperature : 235 $\pm 5^\circ\text{C}$ d. Flux : Rosin e. DIP time : 5 $\pm 1$ sec	More than 95 % of terminal electrode should be covered with new solder

■ **GENERAL TECHNICAL DATA**

Operating temperature range : - 55°C ~ +125°C

Storage Condition : Less than 40°C and 70% RH

Storage Time: 6 months(Size:1005)

12 months(Size:1608 above)

Soldering method: Reflow or Wave Soldering



## X-ON Electronics

Largest Supplier of Electrical and Electronic Components

*Click to view similar products for [Ferrite Beads](#) category:*

*Click to view products by [Inpaq](#) manufacturer:*

Other Similar products are found below :

[CZB1EGTTP700P](#) [CZB1JGTTD152P](#) [CZB2AFTTD800P](#) [CZB2AGTTD121P](#) [CZB2AGTTD601P](#) [CZB2BFTTE600P](#) [PE-0402FB121ST](#)  
[DER0705-2.2](#) [NCB0603R301TR050F](#) [NCB-H1206B680TR300F](#) [CZB1JGTTD221P](#) [CZB1JGTTD600P](#) [CZB2AGTTD301P](#)  
[CZB2BFTTE301P](#) [CZB2BFTTE601P](#) [4221R-1](#) [432703041971](#) [EMI0805R-600](#) [SBY100505T-100Y-N](#) [NCB-GH0402D121TR060F](#)  
[NCB0402P301TR005F](#) [NCB0603R152TR030F](#) [NCB0805A121TR050F](#) [NCB0805A301TR070F](#) [NCB3312K900TR500F](#) [NCB-](#)  
[H1206B101TR300F](#) [NCB0402P221TR030F](#) [NCB0805A102TR040F](#) [NCB1806E151TR020F](#) [NCB-H0402P100TR200F](#) [NCB-](#)  
[H0603R121TR300F](#) [NCB-H0805A220TR600F](#) [NCB-H1206B601TR200F](#) [CZB1JGTTD202P](#) [CBH160808W221T](#) [EMI1206R-600](#)  
[WLBD2012HCU121TH](#) [WLBD2012HCU221TH](#) [WQBD1608HCU121TH](#) [WLBD1608K2U800TP](#) [74279230](#) [BMB2A0080AN4](#)  
[SZ1608F470TF](#) [FBSHC0805-331-302R](#) [HFJ100505T-601Y-N](#) [HFY100505T-221Y-N](#) [SBY060303T-121Y-N](#) [BBPY00160808301Y00](#)  
[SBY100505T-750Y-N](#) [BBPY00100505102Y00](#)