

## MIP 2012-2520 Series

# Specification

<b>Product Name</b>	<b>Power Inductor</b>
<b>Series</b>	<b>MIP Series</b>
<b>Size</b>	<b>EIAJ 2012-2520</b>

**Multilayer Power Inductor (MIP Series) Engineering Spec.**
**■ PRODUCT DETAIL**

Electrical Characteristics			Test Instruments
INDUCTANCE	$\mu\text{H}$ (Ref. Page 6)	TEST FREQ : 1 MHz	●HP4291B RF IMPEDANCE / MATERIAL ANALYZER ●HP4338A/B MILLIOHMMETER
DCR	$\Omega$ (Ref. Page 6)		
RATED CURRENT	mA (Ref. Page 6)	TEST LEVEL : 100 mV	

**■ SHAPES AND DIMENSIONS**

TYPE	2012 (EIA0805)	2016 (EIA0806)	2520 (EIA1008)
L	2.00±0.20	2.00±0.20	2.50±0.20
W	1.25±0.20	1.60±0.20	2.00±0.20
T	0.90±0.10	0.90±0.10	0.90±0.10
E	0.50±0.30	0.50±0.30	0.50±0.30

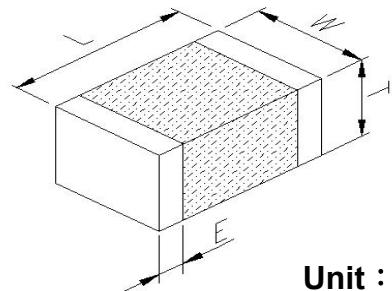

Unit : mm

**PART NUMBER CODE**

**MIP**   **2520**   **4R7**   **M**   **B**   **E**  
**1**   **2**   **3**   **4**   **5**   **6**

- 1 Series Name
- 2 Size Code: The first two digitals: length(mm) , the last two digitals: width(mm)
- 3 Inductance: R=Decimal point , Unit= $\mu\text{H}$
- 4 Tolerance: M= $\pm 20\%$
- 5 Soldering: Green Parts , B=Lead-Free for whole chip
- 6 Packaging: E=Embossed plastic tape, 7" reel

**■ PART NUMBER AND CHARACTERISTICS TABLE**

Part No.	Inductance ±20% (μH)	Test Freq (MHz)	SRF (MHz)	DCR±25% (Ω)	Rated Current (mA)
<b>2012 Series</b>					
MIP2012 2R2MBE	2.2	1	70	0.17	900
MIP2012 4R7MBE	4.7	1	40	0.23	700
<b>2016 Series</b>					
MIP2016 2R2MBE	2.2	1	40	0.12	1100
MIP2016 4R7MBE	4.7	1	20	0.16	900
<b>2520 Series</b>					
MIP2520 1R0MBE	1.0	1	60	0.055	1600
MIP2520 1R5MBE	1.5	1	50	0.070	1500
MIP2520 2R2MBE	2.2	1	40	0.080	1300
MIP2520 3R3MBE	3.3	1	30	0.100	1200
MIP2520 4R7MBE	4.7	1	25	0.110	1100

\*\* For special part number which is not shown in the above table, please refer to appendix.

## ■ TAPE AND REEL SPECIFICATIONS

### Plastic Carrier

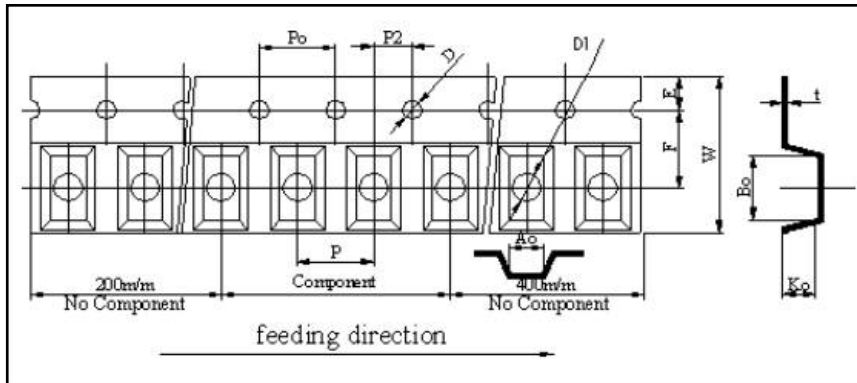

### Taping Dimensions

Unit : mm

	2012	2016	2520
Symbol	<b>E</b>	<b>E</b>	<b>E</b>
W	8.00 ± 0.10	8.00 ± 0.10	8.00 ± 0.10
P	4.00 ± 0.10	4.00 ± 0.10	4.00 ± 0.10
E	1.75 ± 0.10	1.75 ± 0.10	1.75 ± 0.10
F	3.50 ± 0.10	3.50 ± 0.10	3.50 ± 0.10
D	1.55 ± 0.05	1.55 ± 0.05	1.55 ± 0.05
D1	1.00 ± 0.05	1.00 ± 0.05	1.00 ± 0.05
P <sub>0</sub>	4.00 ± 0.10	4.00 ± 0.10	4.00 ± 0.10
10P <sub>0</sub>	40.0 ± 0.20	40.0 ± 0.20	40.0 ± 0.20
P <sub>2</sub>	2.00 ± 0.10	2.00 ± 0.10	2.00 ± 0.10
A <sub>0</sub>	1.40 ± 0.10	1.80 ± 0.10	2.25 ± 0.10
B <sub>0</sub>	2.30 ± 0.10	2.20 ± 0.10	2.80 ± 0.10
K <sub>0</sub> (T)	1.35 ± 0.10	1.15 ± 0.10	1.35 ± 0.10
t	0.22 ± 0.05	0.22 ± 0.05	0.22 ± 0.05

■ REEL DIMENSIONS

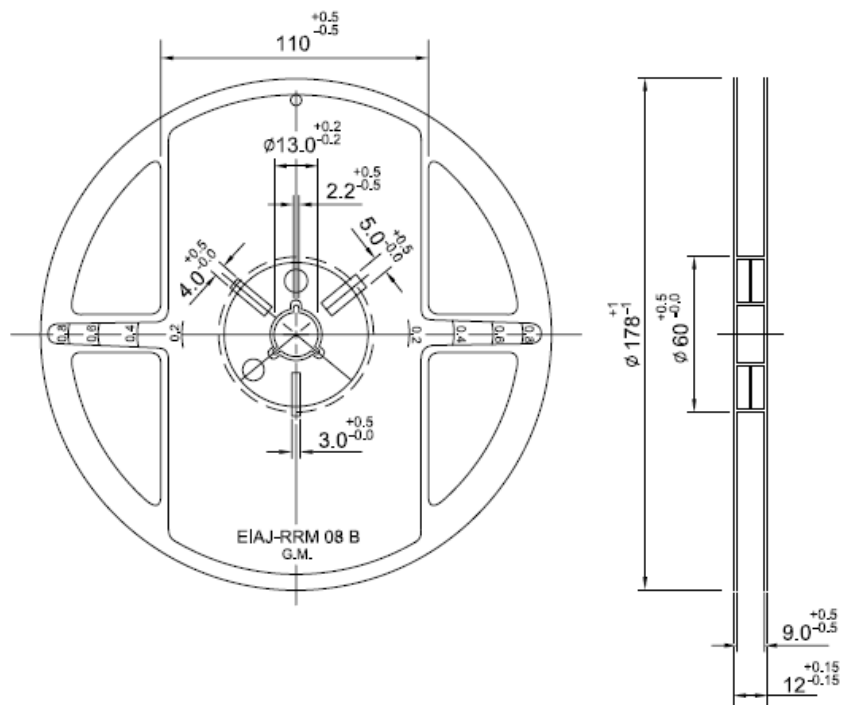

7" Reel Packaging Quantity			
PART SIZE (EIA SIZE)	2012 (0805)	2016 (0806)	2520 (1008)
Qty.(pcs)	3000	3,000	3,000
BOX	5 reels / inner box	5 reels / inner box	5 reels / inner box

■ RECOMMENDED SOLDERING CONDITIONS

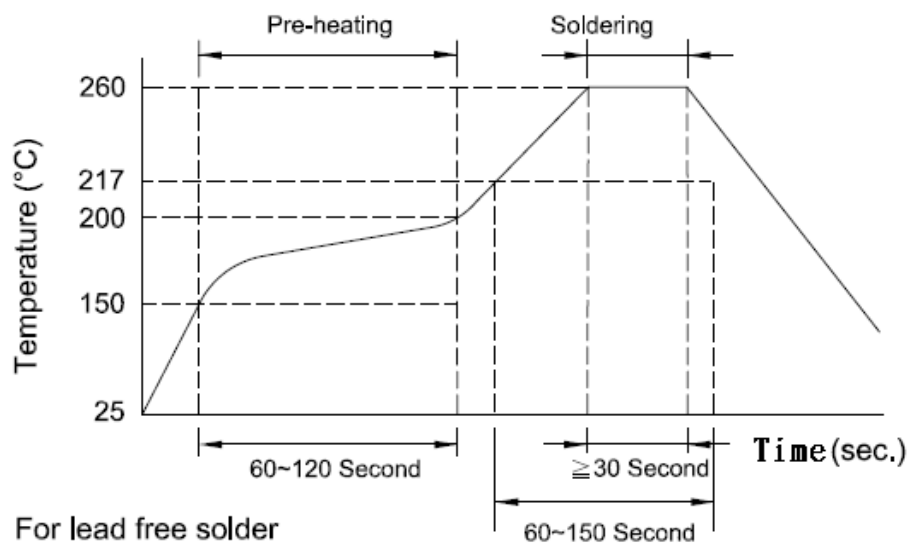

■ LAND PATTERNS FOR REFLOW SOLDERING

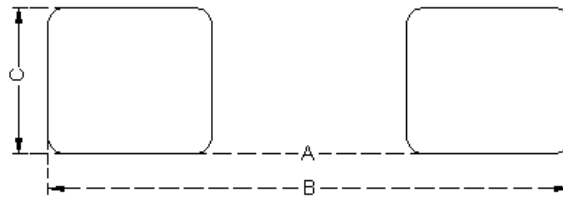

Solder land information :

Unit : mm(inches)

Size	A	B	C
2012	1.0 ~ 1.2 (0.039 ~ 0.047)	3.0 ~ 4.0 (0.118 ~ 0.157)	0.8 ~ 1.1 (0.031 ~ 0.043)
2016	1.0 ~ 1.2 (0.0039 ~ 0.047)	3.0 ~ 4.0 (0.118 ~ 0.157)	1.0 ~ 1.5 (0.0039 ~ 0.0059)
2520	1.2~1.5 (0.047 ~ 0.059)	3.5~4.0 (0.138 ~ 0.157)	1.5~2.0 (0.059 ~ 0.079)

■ RELIABILITY AND TEST CONDITION

Test item	Test condition	Criteria
Resistance to Solder Heat	<ol style="list-style-type: none"> <li>Solder temperature : <math>260 \pm 5^{\circ}\text{C}</math></li> <li>Flux : Rosin</li> <li>DIP time : <math>10 \pm 1</math> sec</li> </ol>	<ol style="list-style-type: none"> <li>More than 95 % of terminal electrode should be covered with new solder</li> <li>No mechanical damage</li> <li>Inductance value should be within <math>\pm 20</math> % of the initial value</li> </ol>
Adhesive Test	<ol style="list-style-type: none"> <li>Reflow temperature : <math>245^{\circ}\text{C}</math> It shall be Soldered on the substrate applying direction parallel to the substrate</li> <li>Apply force(F) : 5 N</li> <li>Test time : 10 sec</li> </ol>	<ol style="list-style-type: none"> <li>No mechanical damage</li> <li>Soldering the products on PCB after the pulling test force <math>&gt; 5</math> N</li> </ol>

Test item	Test condition	Criteria
Steam Aging Test	<ol style="list-style-type: none"> <li>1. Temperature : 93°C</li> <li>2. Test time : 8 hrs</li> <li>3. Solder temperature : 235 ± 5°C</li> <li>4. Flux : Rosin</li> <li>5. DIP time : 5 ± 1 sec</li> </ol>	<ol style="list-style-type: none"> <li>1. More than 95 % of terminal electrode should be covered with new solder</li> </ol>
Temperature Cycle	<ol style="list-style-type: none"> <li>1. Temperature:-40 ~ 85°C For 30 minutes each</li> <li>2. Cycle: 100 cycles</li> <li>3. Measurement:At ambient temperature 24 hours after test completion</li> </ol>	<ol style="list-style-type: none"> <li>1. No mechanical damage</li> <li>2. Inductance should be within ±20% of the initial value</li> </ol>
Operational Life	<ol style="list-style-type: none"> <li>1. Temperature: 85 ± 5°C</li> <li>2. Testing time: 1000 hrs</li> <li>3. Applied current: Full rated current</li> <li>4. Measurement: At ambient temperature 24 hours after test completion</li> </ol>	<ol style="list-style-type: none"> <li>1. No mechanical damage</li> <li>2. Inductance should be within ± 20% of the initial value</li> </ol>
Biased Humidity	<ol style="list-style-type: none"> <li>1. Temperature: 40°C ± 2°C</li> <li>2. Humidity: 90-95 % RH</li> <li>3. Applied current: Full rated current</li> <li>4. Testing time: 1000 hrs</li> <li>5. Measurement: At ambient temperature 24 hours after test completion</li> </ol>	<ol style="list-style-type: none"> <li>1. No mechanical damage</li> <li>2. Inductance should be within ±20% of the initial value</li> </ol>
Rated Current	<p>At ambient temperature &amp; humidity</p> <p>Testing time:5 minutes</p> <p>( under full rated current )</p>	<p>MIP product surface temp : below room temperature plus 40°C</p>

## ■ GENERAL TECHNICAL DATA

Operating temperature range : - 40°C ~ +85°C

Storage Condition : Less than 40°C and 70% RH

Storage Time : 12 months Max.

Soldering method : Reflow or Wave Soldering

■ PART COMPOSITION DECLARATION

Composition part	Homogeneous Material Name.	Element name composition	CAS No.	Substance Mass(%)
Ceramic body	Ferrite Powder	FeO	1309-37-1	46.4%
		CuO	1317-38-0	1.8%
		NiO	1313-99-1	5.4%
		ZnO	1314-13-2	16.1%
	Ceramic Powder	BaZrO3	12009-21-1	0.5%
		Ca2SiO4	1344-95-2	0.1%
		MgSiO3	1343-88-0	0.1%
		ZnO	1314-12-2	0.1%
	Silver Conductor	Ag	7440-22-4	28.0%
	Internal Electrode	Ag	7440-22-4	0.5%
Termination	Plating	Ni	7440-02-0	0.3%
External electrode	Solder	Sn	7440-31-5	0.9%
Total mass (%)				100%



## X-ON Electronics

Largest Supplier of Electrical and Electronic Components

*Click to view similar products for [Fixed Inductors](#) category:*

*Click to view products by [Inpaq](#) manufacturer:*

Other Similar products are found below :

[CR32NP-100KC](#) [70F224AI](#) [MHQ1005P10NJ](#) [MHQ1005P1N0S](#) [MHQ1005P2N4S](#) [MHQ1005P3N6S](#) [MHQ1005P5N1S](#) [MHQ1005P8N2J](#)  
[PE-53601NL](#) [PE-53602NL](#) [PG0936.113NLT](#) [9220-20](#) [9310-16](#) [PM06-2N7](#) [PM06-39NJ](#) [A01TK](#) [1206CS-471XJ](#) [HC2-R47-R](#) [HC8-1R2-R](#)  
[HCF1305-3R3-R](#) [1206CS-151XG](#) [RCH664NP-4R7M](#) [RCP1317NP-391L](#) [DH2280-4R7M](#) [DS1608C-106](#) [B10TJ](#) [B82498B3101J000](#) [ELJ-](#)  
[RE27NJF2](#) [1812CS-153XJ](#) [1812CS-183XJ](#) [1812CS-223XJ](#) [1812LS-104XJ](#) [1812LS-105XJ](#) [1812LS-124XJ](#) [1812LS-154XJ](#) [1812LS-223XJ](#)  
[1812LS-224XJ](#) [1812LS-563XJ](#) [1812LS-683XJ](#) [1812LS-824XJ](#) [NIN-FB101JTR110F](#) [NIN-FB471JTR62F](#) [NIN-FC1R5JTR220F](#) [NIN-](#)  
[HCR15JTRF](#) [NIN-HCR33JTRF](#) [NIN-HDR22JTRF](#) [NIN-HDR82JTRF](#) [NIN-HK2N7STRF](#) [NIN-PA150KTR370F](#) [NIN-PB100KTR550F](#)