

# TVL 0402 01 AB1 Engineering Specification

## 1 Scope

TVL 0402 01 AB1 is a TVS diode designed to protect one power/control line or one low speed signal line from overvoltage hazard of Electrostatic Discharge (ESD).

These interfaces can be used in computer interfaces protection, microprocessors protection, serial and parallel ports protection, control signal lines protection, power lines on PCB protection, latchup protection, etc. The ESD protection of TVS meets the immunity standard of IEC 61000-4-2, level 4 ( $\pm 15\text{kV}$  air,  $\pm 8\text{kV}$  contact discharge).

## 2 Explanation of Part Number

TV    L    0402    01    AB1  
 (1)    (2)    (3)    (4)    (5)

- (1) Product Type : TV=TVS Diode
- (2) Capacitance Code : L=Low Capacitance
- (3) Package Size Code
- (4) Channel Code : 01=1 Channels
- (5) Specialized Specification Code

## 3 . Circuit Diagram & Dimension

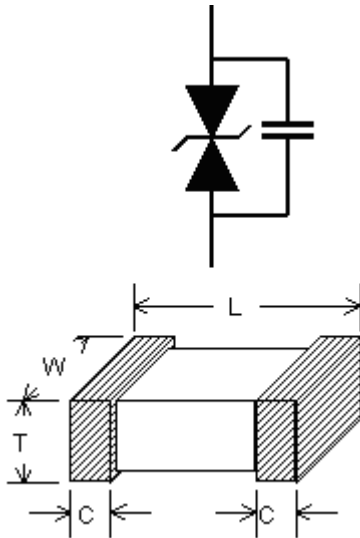

Unit: mm	0402
L	1.10±0.1
W	0.50±0.10
T	0.50±0.10
C	0.25±0.15

UNLESS OTHER SPECIFIED TOLERANCES ON :			INPAQ TECHNOLOGY CO., LTD.	
X=±	X.X=±			X.XX=±
ANGLES=±		HOLEDIA=±		
SCALE : XXXX	UNIT : XXXX	THIS DRAWINGS AND SPECIFICATIONS ARE THE PROPERTY OF INPAQ TECHNOLOGY CO.,LTD.AND SHALL NOT BE REPRODUCED OR USED AS THE BASIS FOR THE MANUFACTURE OR SALE OF APPARATUS OR DEVICES WITHOUT PERMISSION		
DRAWN BY : 張芳榕 <i>Sandy</i>	CHECKED BY : 馮輝明 <i>Fung</i>			
DESIGNED BY : 馮輝明 <i>Fung</i>	APPROVED BY : 劉元文 <i>Wen</i>			
TITLE : TVL 0402 01 AB1 Engineering Specification		DOCUMENT NO.	ENS000024170	SPEC REV. A1

## 4 Specifications

### 4.1 ABSOLUTE MAXIMUM RATINGS

PARAMETER	PARAMETER	RATING	UNITS
Operating Supply Voltage	$V_{DC}$	5.5	V
ESD per IEC 61000-4-2 (Air)	$V_{ESD}$	$\pm 15$	kV
ESD per IEC 61000-4-2 (Contact)		$\pm 8$	
Lead Soldering Temperature	$T_{SOL}$	260 (10 sec.)	$^{\circ}C$

### 4.2 ELECTRICAL CHARACTERISTICS

ELECTRICAL CHARACTERISTICS						
PARAMETER	SYMBOL	CONDITIONS	MINI	TYP	MAX	UNITS
Reverse Stand-Off Voltage	$V_{RWM}$	$T=25^{\circ}C$ .			6	V
Reverse Leakage Current	$I_{Leak}$	$V_{RWM}=5V, T=25^{\circ}C$ .			1	$\mu A$
Reverse Breakdown Voltage	$V_{BV}$	$I_{BV}=1mA, T=25^{\circ}C$ .		10		V
Clamping Voltage	$V_{CL}$	$I_{PP}=1A, tp=8/20\mu s, T=25^{\circ}C$ .		14	15	V
Channel Input Capacitance	$C_{IN}$	$V_R=0V, f=1MHz, T=25^{\circ}C$ .		6		pF

### 4.3 TYPICAL CHARACTERISTICS

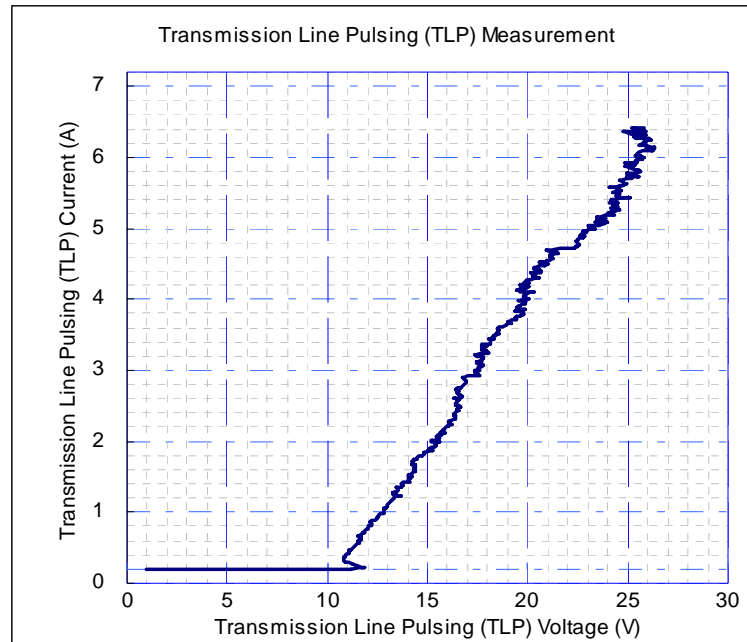

UNLESS OTHER SPECIFIED TOLERANCES ON :

X=±      X.X=±      X.XX=±

ANGLES=±      HOLEDIA=±

SCALE : XXXX      UNIT : XXXX

DRAWN BY : 張芳榕 *Sandy*      CHECKED BY : 馮輝明 *Fung*

DESIGNED BY : 馮輝明 *Fung*      APPROVED BY : 劉元文 *Wen*

TITLE : TVL 0402 01 AB1  
Engineering Specification



INPAQ TECHNOLOGY CO., LTD.

THIS DRAWINGS AND SPECIFICATIONS ARE THE PROPERTY OF INPAQ TECHNOLOGY CO.,LTD.AND SHALL NOT BE REPRODUCED OR USED AS THE BASIS FOR THE MANUFACTURE OR SALE OF APPARATUS OR DEVICES WITHOUT PERMISSION

DOCUMENT NO.      ENS000024170

SPEC REV.      A1

## 5. Taping Package and Label Marking

### 5.1 Packaging method

Products shall be heat-sealed in the chip pocket, spacing pitch 4-mm of plastic carrier tape with cover tape, and the carrier tape shall be reeled to the reel.

### 5.2 Carrier tape dimensions

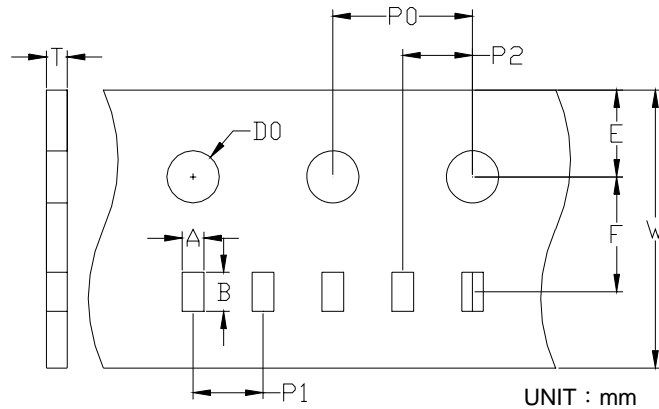

Type	A	B	W	E	F	P0	P1	P2	D0	T
0402	0.58 ±0.03	1.3 ±0.03	8.0 ±0.1	1.75 ±0.05	3.5 ±0.05	4.0 ±0.1	2.0 ±0.05	2.0 ±0.05	1.55 ±0.05	0.60 ±0.03

### 5.3 Taping reel dimensions

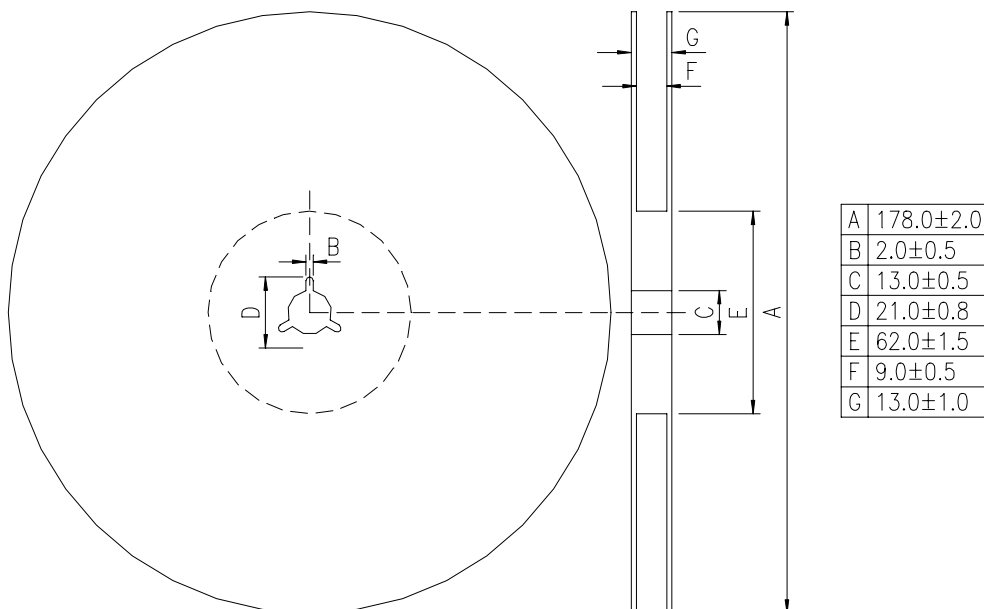

UNLESS OTHER SPECIFIED TOLERANCES ON :

X=±      X.X=±      X.XX=±

ANGLES=±      HOLEDIA=±

SCALE : XXXX      UNIT : XXXX

DRAWN BY : 張芳榕 *Sandy*      CHECKED BY : 馮輝明 *Fung*

DESIGNED BY : 馮輝明 *Fung*      APPROVED BY : 劉元文 *Wen*

TITLE : TVL 0402 01 AB1  
Engineering Specification



INPAQ TECHNOLOGY CO., LTD.

THIS DRAWINGS AND SPECIFICATIONS ARE THE PROPERTY OF INPAQ TECHNOLOGY CO.,LTD.AND SHALL NOT BE REPRODUCED OR USED AS THE BASIS FOR THE MANUFACTURE OR SALE OF APPARATUS OR DEVICES WITHOUT PERMISSION

DOCUMENT  
NO.

ENS000024170

SPEC REV.  
A1

### 5.4 Taping specifications

There shall be the portion having no product in both the head and the end of taping, and there shall be the cover tape in the head of taping.

### 5.5 Label Marking

The label specified as follows shall be put on the side of reel.

- (1) Part No.
- (2) Quantity
- (3) Lot No.

\*Part No. And Quantity shall be marked on outer packaging.

### 5.6 Quantity of products in the taping package

- (1) Standard quantity : 10,000pcs/Reel for TVL0402 Series
- (2) Shipping quantity is a multiple of standard quantity.

## 6. Precautions for Handling

### 6.1 Solder cream in reflow soldering

Refer to the recommendable land pattern as printing mask pattern for solder cream.

- (1) Print solder in a thickness of 150 to 200 μm.
- (2) Dimensions: millimeters (inches)

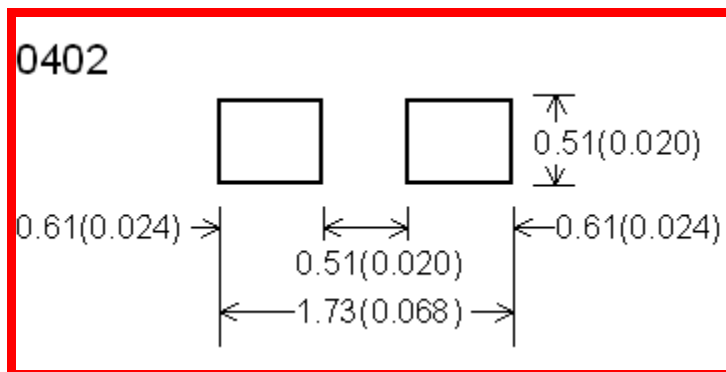

### 6.2 Precaution for handling of substrate

Do not exceed to bend the board after soldering this product extremely.

(Reference examples)

- Mounting place must be as far as possible from the position, which is close to the break line of board, or on the line of large holes of board.
- Do not bend extremely the board, in mounting another components.

If necessary, use back-up pin (support pin) to prevent from bending extremely.

- Do not break the board by hand. We recommend using the machine or the jig to break it.

<b>UNLESS OTHER SPECIFIED TOLERANCES ON :</b>			<b>INPAQ TECHNOLOGY CO., LTD.</b>	
X=±	X.X=±			
<b>ANGLES=±</b>		<b>HOLEDIA=±</b>		
<b>SCALE : XXXX</b>		<b>UNIT : XXXX</b>		
<b>DRAWN BY : 張芳榕 <i>Sandy</i></b>		<b>CHECKED BY : 馮輝明 <i>Fung</i></b>		
<b>DESIGNED BY : 馮輝明 <i>Fung</i></b>		<b>APPROVED BY : 劉元文 <i>Wen</i></b>		
<b>TITLE : TVL 0402 01 AB1</b>		<b>DOCUMENT NO.</b>	<b>ENS000024170</b>	<b>SPEC REV.</b>
<b>Engineering Specification</b>				<b>A1</b>

### 6.3 Precaution for soldering

Note that rapid heating, rapid cooling or local heating will easily damage this product. Do not give heat shock over 100°C in the process of soldering. We recommend taking preheating and gradual cooling.

### 6.4 Recommendable reflow soldering

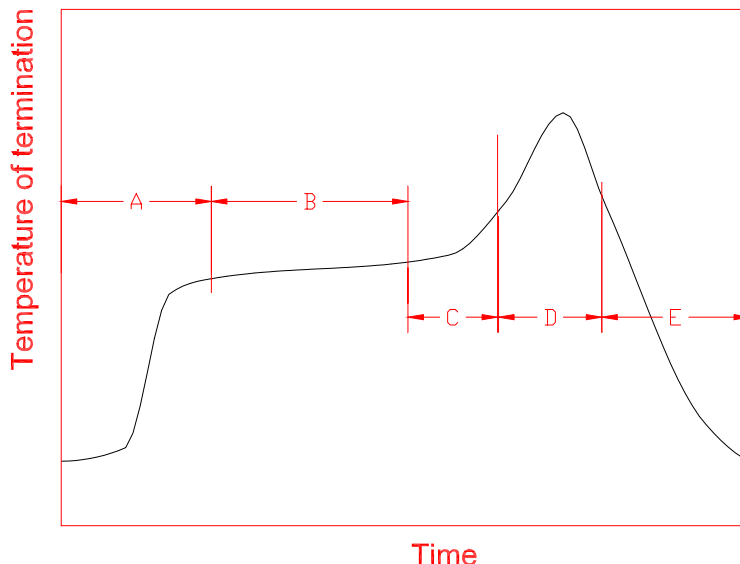

A	1 <sup>st</sup> rising temperature	The normal to Preheating temperature	30s to 60s
B	Preheating	140°C to 160°C	60s to 120s
C	2 <sup>nd</sup> rising temperature	Preheating to 200°C	20s to 40s
D	Main heating	if 220°C if 230°C if 240°C if 250°C if 260°C	50s~60s 40s~50s 30s~40s 20s~40s 20s~40s
E	Regular cooling	200°C to 100°C	1°C/s ~ 4°C/s

\*According to J-STD-020C

### 6.5 Soldering gun procedure

Note the follows, in case of using solder gun for replacement.

- (1) The tip temperature must be less than 280°C for the period within 3 seconds by using soldering gun less than 30 W.
- (2) The soldering gun tip shall not touch this product directly.

### 6.6 Soldering volume

Note that excess of soldering volume will easily get crack the body of this product.

UNLESS OTHER SPECIFIED TOLERANCES ON :			INPAQ TECHNOLOGY CO., LTD.	
X=±	X.X=±			
ANGLES=±		HOLEDIA=±		
SCALE : XXXX		UNIT : XXXX		
DRAWN BY : 張芳榕 <i>Sandy</i>		CHECKED BY : 馮輝明 <i>Fung</i>		
DESIGNED BY : 馮輝明 <i>Fung</i>		APPROVED BY : 劉元文 <i>Wen</i>		
TITLE : TVL 0402 01 AB1 Engineering Specification		DOCUMENT NO.	ENS000024170	SPEC REV. A1

## X-ON Electronics

Largest Supplier of Electrical and Electronic Components

*Click to view similar products for [ESD Suppressors / TVS Diodes](#) category:*

*Click to view products by [Inpaq](#) manufacturer:*

Other Similar products are found below :

[NTE4902](#) [P4SMAJ15A](#) [P4SMAJ26A](#) [SMAJ400CA-TP](#) [TGL34-47CA](#) [ESDAULC45-1BF4](#) [SM1605E3/TR13](#) [SMF20A-TP](#) [P4SMAJ12A](#)  
[CPDUR24V-HF](#) [CPDQC5V0USP-HF](#) [CPDQC5V0-HF](#) [MPLAD30KP280A](#) [MPLAD30KP45CAE3](#) [MMBZ27VCLQ-7-F](#) [MMAD1108/TR13](#)  
[MPLAD30KP24A](#) [MPLAD30KP30CAE3](#) [ACPDQC5V0R-HF](#) [DFLT170A-7](#) [NTE4900](#) [NTE4926](#) [NTE4938](#) [JANTX1N6144A](#)  
[JANTX1N6057A](#) [SMF22A-TP](#) [SMF12A-TP](#) [SLVU2.8-TP](#) [SMLJ6.5CA-TP](#) [SMAJ6.5CA-TP](#) [MMAD1108E3/TR13](#) [JANTX1N6160A](#)  
[D5V0M1U2LP3-7](#) [SMAJ400A-TP](#) [AOZ8811DT-03](#) [AOZ8831DI-05](#) [AOZ8831DT-03](#) [SMAJ188CA](#) [3SMC33CA BK](#) [CPDQC3V3C-HF](#)  
[CPDQC12VE-HF](#) [GRPADATAJANTX1N6041A](#) [MPLAD30KP170CA](#) [82357120100](#) [5.0SMLJ15CA-TP](#) [5KP18A-TP](#) [P6KE8.2A-TP](#)  
[MPLAD30KP43CAE3](#) [SMAJ43A-TP](#) [D26V0H1U2LP16-7](#)