



InPlay NanoBeacon™ IN100 Development Kit User Manual



NanoBeacon™

 **Contents**

About Documentation	3
1. General Description	4
2. Hardware Description	6
3. Schematic	10
4. Revision History	11
5. Legal Disclaimer.....	11

Preliminary

 **List of Figures**

Figure 1 : Development Kit	4
Figure 2 : Development board.....	5
Figure 3 : Programmer board.....	5
Figure 4 : Development board.....	6
Figure 5 : Programmer board.....	9
Figure 6 : Development Kit schematic	10

Preliminary

About Documentation

Document name	InPlay NanoBeacon™ IN100 Development Kit user manual	
Part number	IN1BN-DKCO-100-C0	
Control number	IN1IDOC-HW-IN1BN-EN-V1.01	External user
Revision	V1.02	

Product status	Document content	Data status
In development	Target specification / MRD	Initial release
Engineering Document	Main functions and features description	Preliminary version
Official release document	Description of all functional features	Subject to revision and updates

This document applies to the following products:

Part number	Applicable products	Document status
IN1BN-DKCO-100-C0	IN100-D1-R-RC0I	Engineering sample
	IN100-Q1-R-RC0I	In development
	IN100-D1-R-RC0F	Engineering sample
	IN100-Q1-R-RC0F	In development

1. General Description

IN1BN-DKCO-100-C0 is an InPlay NanoBeacon™ development kit that includes three IN100 development boards and one programmer board.

The development kit provides all the I/Os available on IN100 (QFN18 package) that allow users to easily connect peripheral devices such as sensors, and by connecting the RF cables using SMA, users can evaluate the RF performance more accurately. In addition, an external power supply can be selected to provide a wide range of voltages for the IN100 device or system evaluation.

A kit contains three development boards and one programmer board as shown in Figure 1.

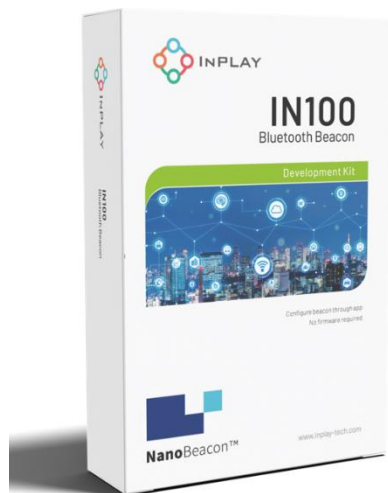

IN100 Development board



Programmer board

Figure 1 : Development Kit

Development Board

- NanoBeacon™ IN100 SoC device
- 3.5mm SMA female RF connector
- Device I/O pins
- Reset button
- CR1220 coin cell battery socket
- Power supply source selection switch: On-board coin cell Battery / External power supply / Programmer board power supply
- System current measurement jumper provision
- Programming interface female connector

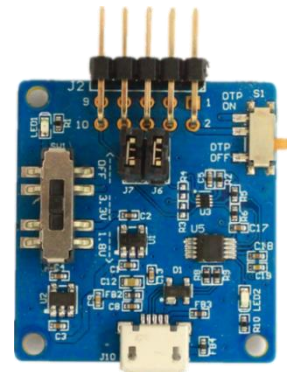

Figure 2 : Development board

Programmer Board

- Programming interface male connector
- OTP (eFuse) memory programming power switch
- Programmer board output power selection switch : 1.8V / 3.3V / No connect
- OTP memory (eFuse) burning LED indicator
- On-board USB to UART convertor
- Micro USB female connector

Figure 3 : Programmer board



2. Hardware Description

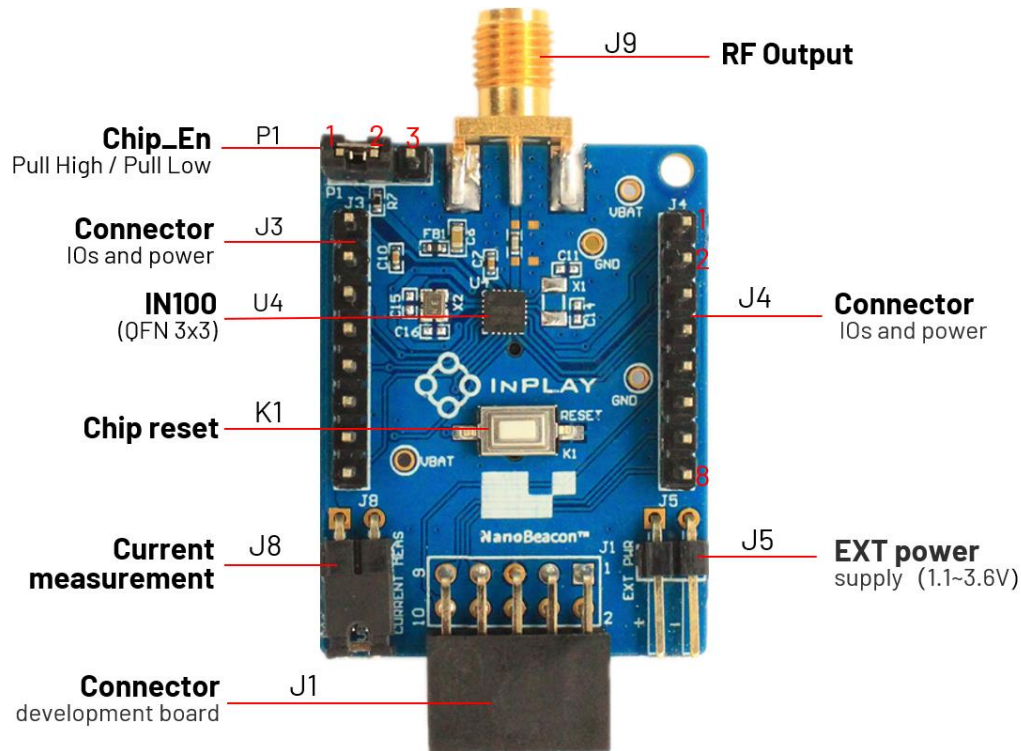

Figure 4 : Development board

Development board Connectors/Pins/Jumpers/Button Definition

Designator	Function	Description		
		Pin #	Pin name	Description
J1	Connector (development board)	1	VDDQ	OTP (eFuse) memory programming power pin
		2	MGPI07	IN100 mixed-signal GPIO
		3	VBAT	System power supply, connected to the VCC pin of the IN100 through J8
		4	VBAT	System power supply, connected to the VCC pin of the IN100 through J8
		5	GND	Ground
		6	GND	Ground
		7	GPIO1	IN100 digital GPIO, Default is IN100 UART_TX
		8	MGPI05	IN100 mixed-signal GPIO
		9	GPIO0	IN100 digital GPIO, Default is IN100 UART_RX
		10	MGPI04	IN100 mixed-signal GPIO

Designator	Function	Description		
J2	Connector (programmer board)	Pin #	Pin name	Description
		1	NC	No connect
		2	VDDQ	OTP (eFuse) memory programming power pin Power On/Off controlled by S1
		3	PWR	Power supply, controlled by SW1
		4	PWR	Power supply, controlled by SW1
		5	GND	Ground
		6	GND	Ground
		7	NC	No connect
		8	UART_RX	UART interface, connect to IN100 UART_TX
		9	NC	No connection
10	UART_TX	UART interface, connect to IN100 UART_RX		
J3	Connector for IOs and power	Pin #	Pin name	Description
		1	Reset	Connect to the Chip_EN pin of IN100 and pull low to disable the chip, pull high to enable the chip
		2	VBAT	System power supply, connect to IN100 VCC pin through J8
		3	MGPI07	IN100 mixed-signal GPIO
		4	MGPI06	IN100 mixed-signal GPIO
		5	MGPI05	IN100 mixed-signal GPIO
		6	GND	Ground
		7	SW0	IN100 built-in load switch for power supply
8	SW1	IN100 built-in load switch for grounding		
J4	Connector for IOs and power	Pin #	Pin name	Description
		1	VDDQ	OTP (eFuse) memory programming power pin
		2	MGPI04	IN100 mixed-signal GPIO
		3	GPIO3	IN100 digital signal GPIO
		4	GPIO2	IN100 digital signal GPIO
		5	GND	Ground
		6	VBAT	System power supply, connected to the VCC pin of the IN100 through J8
		7	GPIO0	IN100 digital GPIO, Default is IN100 UART_RX
8	GPIO1	IN100 digital GPIO, Default is IN100 UART_TX		

Designator	Function	Description
J5	External power supply	External power supply (1.1~3.6V input). When this power supply is available, keep no coin cell battery installed and switch the programmer board SW1 to OFF.
J8	Current measurement	<ul style="list-style-type: none"> - For normal operation, a jumper needs to be installed - For current measurement <ul style="list-style-type: none"> • Remove the jumper J8 on the board • Power pin 1(VCC) of J8 with an external power supply with an ammeter. Initially, set the voltage same as the voltage presented on J8 pin 2 (VBAT) • Press the K1 button to reset the device and run the user configuration in RAM (refer to the "Run in RAM" operation in the NanoBeacon™ Configuration Tool User Manual for details) • Disconnect the programmer board from the development board • Set the external power supply to the voltage at which you want to measure the current, and then measure the current.
J9	RF TX output connector	The female 3.5mm SMA RF connector for connecting an external antenna (Note: antenna is not provided in the kit)
P1	Chip_EN	<ul style="list-style-type: none"> - Chip_EN ON: Connect pin 1 and 2. This is to enable the device. - Chip_EN OFF: Connect pin 2 and 3. This is to disable the device.
K1	Chip reset	Chip reset button

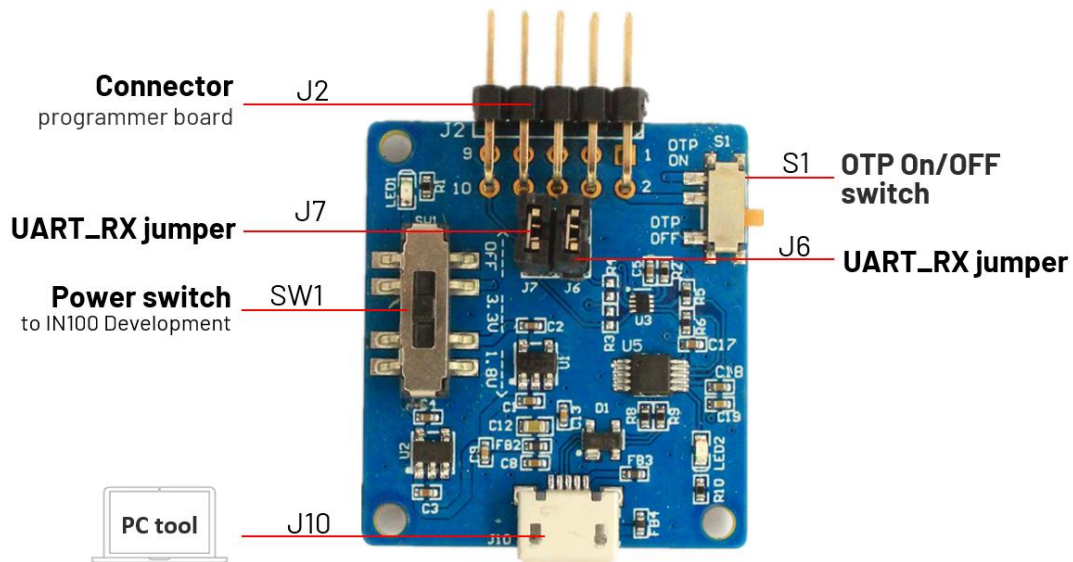

Figure 5 : Programmer board

Programmer board Connectors/Pins/Jumpers/Button Definition

Designator	Function	Description
J6, J7	PC UART interface jumpers	The UART between the device (IN100) and PC is disconnected when no jumpers are installed.
J10	USB interface	Micro USB female connector for connecting with a PC
S1	OTP ON/OFF	OTP memory power supply switch. - Switch On: eFuse (OTP) memory programming is enabled, J2 pin2(FUSE) output 3.3V and connected to the device's (IN100) VDDQ. - Switch OFF: eFuse (OTP) memory programming is disabled. J2 pin2 will be grounded and connected to VDDQ of the device (IN100).
SW1	Power supply source select switch	-1.8V: 1.8V output for the development board -3.3V: 3.3V output for the development board -OFF: No power is provided by the programmer board. The power is provided by the development board itself.

3. Schematic

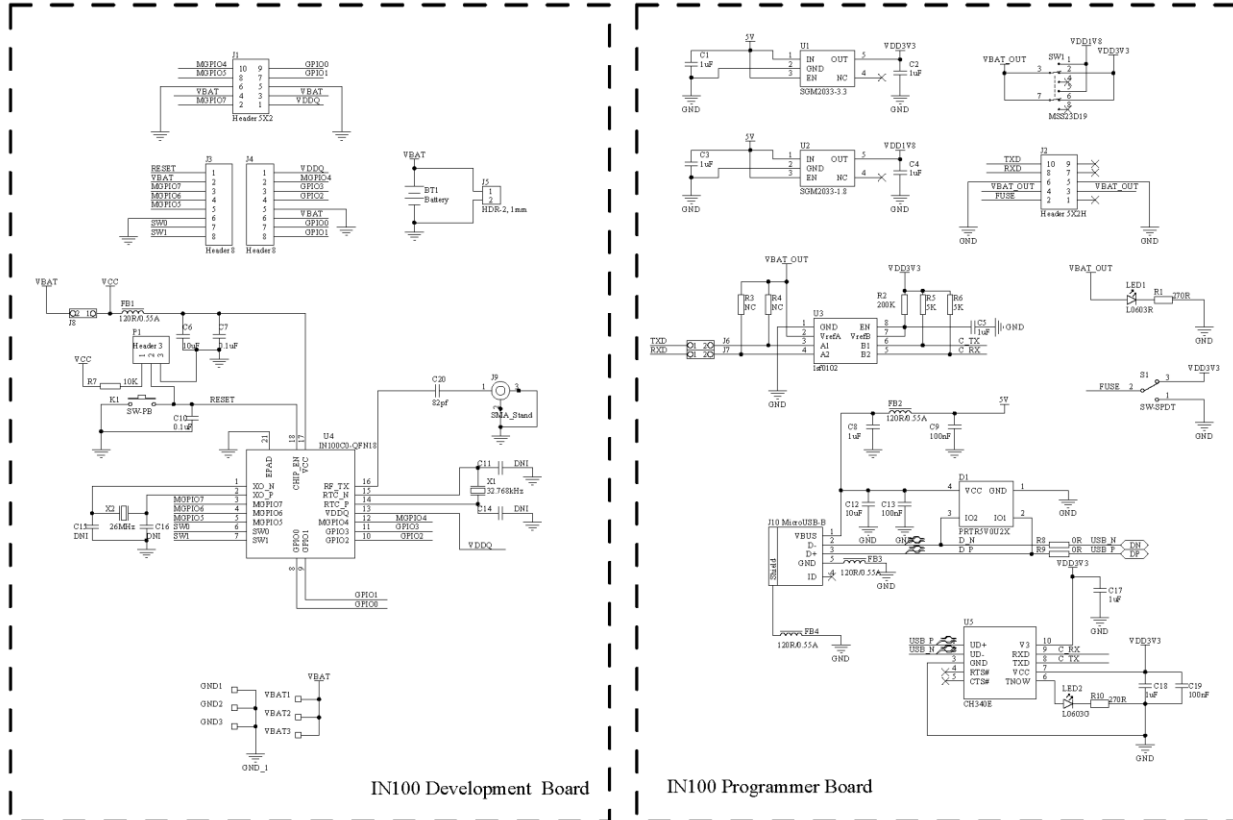

Figure 6 : Development Kit schematic

4. Revision History

Revision	Description	Update date	Owner
V1.0	Preliminary Version	Nov 16, 2021	Eric. Xu
V1.01	Typo fixes	Mar 16, 2022	J. Wu
V1.02	Update SMA Description	Sep 16, 2022	J. Wu

5. Legal Disclaimer

InPlay has made every attempt to ensure the accuracy and reliability of the information provided on this document. However, the information is provided “as is” without warranty of any kind. The content of the document will subject to change without prior notice. InPlay does not accept any responsibility or liability for the accuracy, content, completeness, legally, or reliability of the information contained on this document. We shall not be liable for any loss or damage of whatever nature (direct, indirect, consequential or other) whether arising in contract or otherwise, which may arise as a result of your use of (or inability to use) this document, or from your use of (or failure to use) the information on this document. InPlay Inc and its company logo are registered trademarks of InPlay Inc with its registered office at 1 Technology Drive, STE J728, Irvine, CA, USA 92618.

X-ON Electronics

Largest Supplier of Electrical and Electronic Components

Click to view similar products for [Bluetooth Development Tools - 802.15.1 category](#):

Click to view products by [InPlay manufacturer](#):

Other Similar products are found below :

[1628](#) [BCM9WICED_SENSE](#) [STEVAL-SPBT2ATV3](#) [RSL15-EVB](#) [RBL06FTR030](#) [RBL06FTR010](#) [RBL06FTR020](#) [3026](#) [MIKROE-2471](#)
[MOD-NRF8001](#) [BLE-IOT-GEVB](#) [DVK-BT830-SA-01](#) [EVAL_PAN1026](#) [EVAL_PAN1720](#) [EVAL_PAN1740](#) [2267](#) [2479](#) [2633](#)
[ENW89820AY2F](#) [ENW89820AY1F](#) [STEVAL-IDB005V1D](#) [STEVAL-IDB001V1](#) [MIKROE-2545](#) [2995](#) [CY8CKIT-062-BLE](#) [CYBLE-](#)
[013025-EVAL](#) [CYBLE-214015-EVAL](#) [CYW920706WCDEVAL](#) [2829](#) [DFR0267](#) [DFR0296](#) [TEL0073](#) [BM-70-CDB](#) [AC320032-3](#) [ENW-](#)
[89847AWKF](#) [CYBLE-212006-EVAL](#) [WSM-BL241-ADA-008DK](#) [SLWRB4303A](#) [FXX-3041-ESS](#) [UGMZ2AA_EVK](#) [ASD2116-R](#) [ISP1507-](#)
[AX-EB](#) [ISP1507-AX-TB](#) [RN-4871-PICTAIL](#) [DA14695-00HQDEVKT-P](#) [DA14695-00HQDEVKT-U](#) [BMD-200-EVAL-S](#) [1715](#) [2269](#) [2746](#)