

10/100/1000 BASE-T SINGLE & DUAL PORT TRANSFORMER MODULE

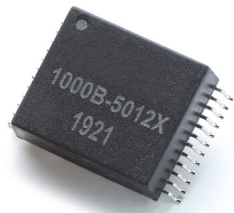

Ruggedized



- Compliant with IEEE 802.3ab for 1000 Base-T
- 350µH OCL with 8mA bias at extended temperatures
- Storage Temperature: -55°C to +125°C
- Two Operating Temperature versions available:
 - Standard: -40°C to +85°C
 - Extended: -55°C to +125°C
- 235°C peak reflow temperature (MSL 3)
- Lead finish: Sn63/Pb37 (RoHS-compliant version available with 100% pure tin)
- 245°C peak reflow temperature for RoHS version (MSL 4)

Electrical Specifications @ 25°C

Part Number	Insertion Loss (dB MAX)				Return Loss (dB MIN)				Crosstalk (dB MIN)			CM to CM Rejection (dB MIN)			DM to CM Rejection (dB MIN)			HiPot (Vrms)
	0.10 MHz	30 MHz	60 MHz	100 MHz	30 MHz	60 MHz	80 MHz	100 MHz	30 MHz	60 MHz	100 MHz	30 MHz	60 MHz	100 MHz	30 MHz	60 MHz	100 MHz	
1000B-5009	1.4	1.4	1.4	1.4	18	12	10	8	43	37	31	30	25	18	40	35	30	1500
1000B-5009X	1.4	1.4	1.4	1.4	18	12	10	8	43	37	31	30	25	18	40	35	30	1500
1000B-5012	1.2	1.2	1.2	1.2	18	12	10	8	43	37	31	40	35	30	43	37	30	1500
1000B-5012X	1.2	1.2	1.2	1.2	18	12	10	8	43	37	31	40	35	30	43	37	30	1500
1000B-5014	1.4	1.4	1.4	1.4	16	12	10	8	43	37	31	33	30	28	43	37	30	1500
1000B-5014X	1.4	1.4	1.4	1.4	16	12	10	8	43	37	31	33	30	28	43	37	30	1500
1000B-5016	1.2	1.2	1.2	1.2	18	12	12	10	43	37	31	30	23	17	40	35	30	1500

NOTES:

- Add suffix "NL" for RoHS compliant version; i.e. 1000B-5009 becomes 1000B-5009NL. NL parts have 100% SN Lead Finish (MSL:4)
- For Tape & Reel packaging, add "T" suffix at the end of the part number: i.e. 1000B-5009NLT.
- Add suffix "X" for extended temperature version; i.e. 1000B-5009 becomes 1000B-5009X. (*1000B-5016 does not offer X-version)

Mechanicals

Electrical Schematics

1000B-5009/X

Dimensions: inch [mm]
Tolerance (unless otherwise specified): ±0.010 [0.25]

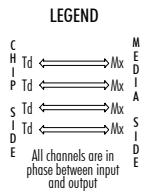
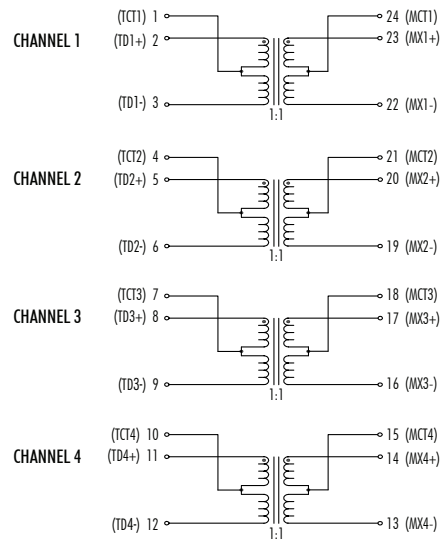
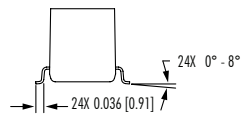
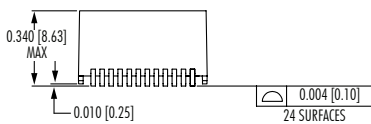
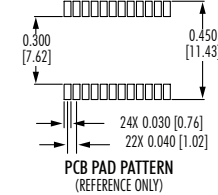
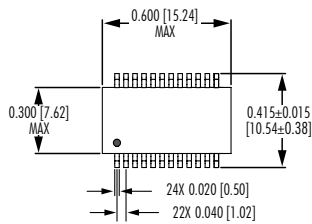

Performance warranty of products offered on this data sheet is limited to the parameters specified. Data is subject to change without notice. Other brand and product names mentioned herein may be trademarks or registered trademarks of their respective owners. © Copyright, 2020. iNRCORE, LLC. All rights reserved.

10/100/1000 BASE-T SINGLE & DUAL PORT TRANSFORMER MODULE



Ruggedized

1000B-5016

Mechanicals

Dimensions: inch [mm]
Tolerance (unless otherwise specified): ±0.010 [0.25]

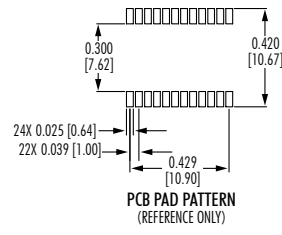
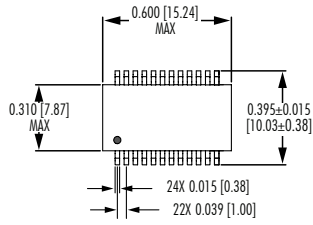

PCB PAD PATTERN
(REFERENCE ONLY)

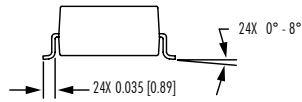
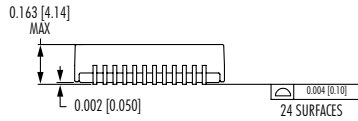

Electrical Schematics

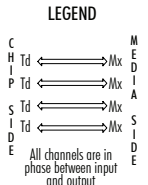
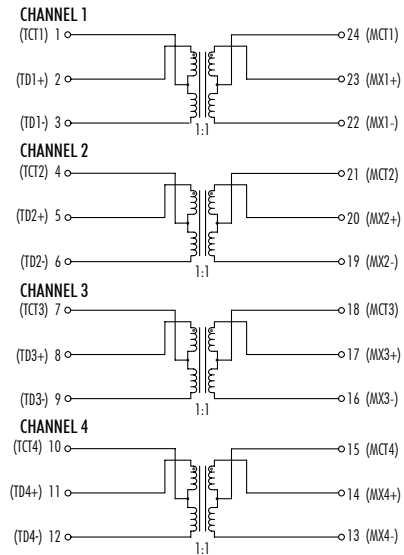

10/100/1000 BASE-T SINGLE & DUAL PORT TRANSFORMER MODULE



Ruggedized

Tin/Lead Recommended Reflow Profile (Based on J-STD-020D)

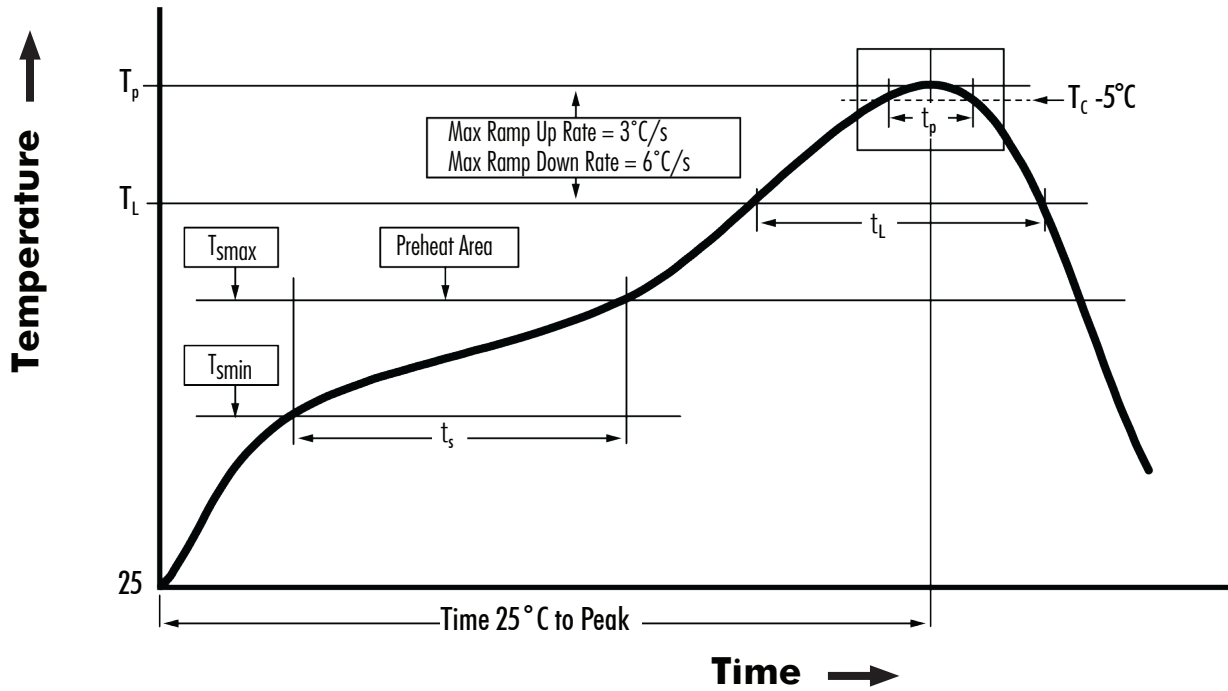

T_{SMIN} (°C)	T_{SMAX} (°C)	T_L (°C)	T_P (°C MAX)	t_s (s)	t_L (s)	t_p (s MAX)	Ramp-up rate (T_L to T_p)	Ramp-down rate (T_p to T_L)	Time 25°C to peak temperature (s MAX)
100	150	183	235	60 - 120	60 - 150	20	3°C/s MAX	6°C/s MAX	360

NOTES:

1. All temperatures measured on the package leads.
2. Maximum times of reflow cycle: 2



10/100/1000 BASE-T SINGLE & DUAL PORT TRANSFORMER MODULE



Ruggedized

Non-Lead Recommended Reflow Profile (Based on J-STD-020D)

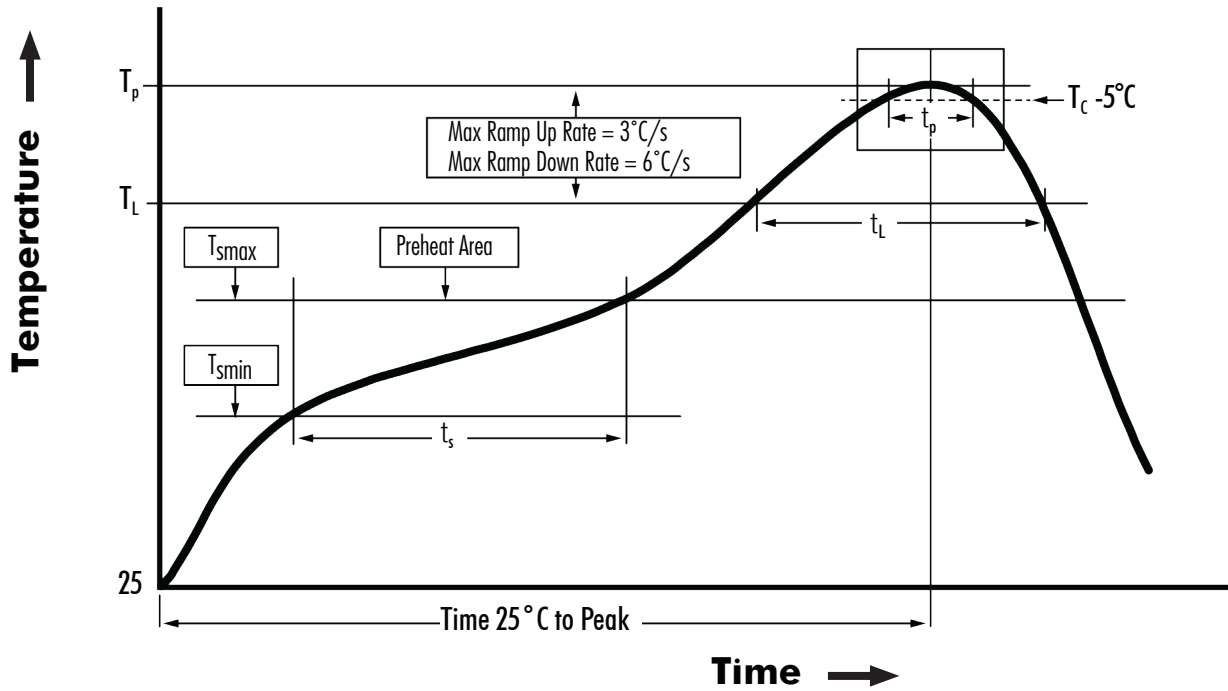

T_{SMIN} (°C)	T_{SMAX} (°C)	T_L (°C)	T_P (°C MAX)	t_s (s)	t_L (s)	t_p (s MAX)	Ramp-up rate (T_L to T_p)	Ramp-down rate (T_p to T_L)	Time 25°C to peak temperature (s MAX)
150	200	217	245	60 - 120	60 - 150	30	3°C/s MAX	6°C/s MAX	480

NOTES:

1. All temperatures measured on the package leads.
2. Maximum times of reflow cycle: 2



iNRCORE, LLC
311 Sinclair Road, Bristol, PA 19007-6812 USA
Tel: +1.215.781.6400 Fax: +1.215.781.6430

www.iNRCORE.com

Performance warranty of products offered on this data sheet is limited to the parameters specified. Data is subject to change without notice. Other brand and product names mentioned herein may be trademarks or registered trademarks of their respective owners. © Copyright, 2020. iNRCORE, LLC. All rights reserved.

M557.B (11/21)

X-ON Electronics

Largest Supplier of Electrical and Electronic Components

Click to view similar products for [Audio Transformers](#) / [Signal Transformers](#) category:

Click to view products by [iNRCORE](#) manufacturer:

Other Similar products are found below :

[CU4S0506AT-2655-H1](#) [MGPWT-00449-P](#) [PE-64961](#) [1812WBT2-4](#) [BX1194WNL](#) [1879479-1](#) [PA1528ANL](#) [T1137NLT](#) [PE-65848FNLT](#)
[H5019EFNL](#) [CX2045ALNLT](#) [TG1G-E201NV6LF](#) [MGPWT-00059-P](#) [MGPWT-00266-P](#) [MGPWT-00278-P](#) [MGPWT-00431-P](#) [TTC-100](#)
[TTC-143-H](#) [TTC-5032-1](#) [4-1879391-0](#) [100213](#) [T1142NL](#) [TG1G-S001NZLF](#) [T1124NL](#) [1879732-1](#) [2-1879391-5](#) [MABA-010321-CT1A42](#)
[TX1341NL](#) [H0013FNL](#) [H5020FNL](#) [H2009FNLT](#) [H5004NLT](#) [S553-5999-52-F](#) [SCMS7D43AY100PT1](#) [T5008NLT](#) [PE-68517T](#) [MGPWT-](#)
[00339-P](#) [H5014FNLT](#) [TX1473NLT](#) [PE-69011NLT](#) [CX2043LNLT](#) [H7137FNLT](#) [H1259NLT](#) [TX1344NLT](#) [LM-LP-1005L](#) [H0013NLT](#)
[S558-5500-JV](#) [TX1193NLT](#) [T7015NL](#) [T1124NLT](#)