

Intel[®] RealSense[™] Tracking Camera

Datasheet

Intel[®] RealSense[™] Tracking Camera T265, Intel[®] RealSense[™] Tracking Module T261

September 2019

Revision 004

You may not use or facilitate the use of this document in connection with any infringement or other legal analysis concerning Intel products described herein. You agree to grant Intel a non-exclusive, royalty-free license to any patent claim thereafter drafted which includes subject matter disclosed herein.

No license (express or implied, by estoppel or otherwise) to any intellectual property rights is granted by this document.

Intel technologies' features and benefits depend on system configuration and may require enabled hardware, software or service activation. Learn more at Intel.com, or from the OEM or retailer.

No computer system can be absolutely secure. Intel does not assume any liability for lost or stolen data or systems or any damages resulting from such losses.

The products described may contain design defects or errors known as errata which may cause the product to deviate from published specifications. Current characterized errata are available on request.

Intel disclaims all express and implied warranties, including without limitation, the implied warranties of merchantability, fitness for a particular purpose, and non-infringement, as well as any warranty arising from course of performance, course of dealing, or usage in trade.

Intel technologies' features and benefits depend on system configuration and may require enabled hardware, software or service activation. Learn more at intel.com, or from the OEM or retailer.

All information provided here is subject to change without notice. Contact your Intel representative to obtain the latest Intel product specifications and roadmaps.

Copies of documents which have an order number and are referenced in this document may be obtained by calling 1-800-548-4725 or visit www.intel.com/design/literature.htm.

By using this document, in addition to any agreements you have with Intel, you accept the terms set forth below.

Contact your local Intel sales office or your distributor to obtain the latest specifications and before placing your product order.

Intel, RealSense and the Intel logo are trademarks of Intel Corporation in the U.S. and/or other countries.

*Other names and brands may be claimed as the property of others.

Copyright © 2019, Intel Corporation. All rights reserved.

Contents

- 1 Description and Features8
- 2 Introduction.....9
 - 2.1 Purpose and Scope of this Document.....9
 - 2.2 Terminology9
 - 2.3 Tracking Camera Technology Overview.....9
 - 2.4 Tracking System10
 - 2.5 Intel® RealSense™ Tracking Module T26110
 - 2.6 Intel® RealSense™ Tracking Camera T26510
- 3 Component Specification.....11
 - 3.1 Tracking Camera system Components.....11
 - 3.2 Intel® RealSense™ Tracking Module T26111
 - 3.2.1 Inertial Measurement Unit.....12
 - 3.2.2 Fisheye Imagers12
 - 3.2.3 Tracking Module Connector Plug.....13
 - 3.2.4 Tracking Module Label15
 - 3.2.5 Stiffener16
 - 3.2.6 Mechanical Dimensions.....16
 - 3.2.7 Tracking Module Storage and Operating Conditions16
 - 3.2.8 Tracking Module Power Requirements.....16
 - 3.3 Intel® RealSense™ Tracking Camera T265 Device.....17
 - 3.3.1 Intel® RealSense™ Tracking Camera T265 Mechanical Dimensions17
 - 3.3.2 Intel® RealSense™ Tracking Camera T265 Thermals17
 - 3.3.3 Intel® RealSense™ Tracking Camera T265 Storage and Operating Conditions18
 - 3.3.4 Product Identifier and Material Code.....18
- 4 Functional Specification19

- 4.1 Boot Device Information.....19
- 5 Software.....20
 - 5.1 Intel® RealSense™ Software Development Kit 2.020
- 6 System Integration.....21
 - 6.1 System Level Block Diagram21
 - 6.2 Intel® RealSense™ Tracking Module T261 Module Flex.....21
 - 6.3 Thermals21
 - 6.3.1 Passive Heat Spreader22
 - 6.4 Cover Design Guidance23
 - 6.5 Mounting Guidance24
 - 6.5.1 Screw Mount24
 - 6.5.2 Occlusion Avoidance25
 - 6.6 Gaskets.....26
 - 6.6.1 Dust Protection27
 - 6.7 Center of Tracking Location.....27
 - 6.8 Tracking System Coordinate System.....28
- 7 Product Regulatory30
 - 7.1 Manufacturer’s Information30
 - 7.2 NRTL Statement.....30
 - 7.3 Ecology Compliance.....31
 - 7.3.1 RoHS Declaration31

Figures

- Figure 3-1. Intel® RealSense™ Tracking Module T261 Front View11
- Figure 3-2. Board to Board Receptacle Pin Map on T261 Module13
- Figure 3-3. Intel® RealSense™ Tracking Camera T265.....17
- Figure 6-1. System Block Diagram21
- Figure 6-2. Passive Heat Spreader.....23

Figure 6-3. T261 Module Screw Mount.....24

Figure 6-4. Example for VR: HMD Positioning for Controller25

Figure 6-5. Example for VR: Front Mounting Advantages26

Figure 6-6. Example for VR: Top Mounting Challenges.....26

Figure 6-7. Intel® RealSense™ Tracking Module T261 Center of Tracking Location27

Figure 6-8. Intel® RealSense™ Tracking Camera T265 Center of Tracking Location28

Figure 6-9. Tracking System Coordinate System.....28

Figure 7-1. NRTL Certification.....31

Tables

Table 2-1. Tracking Module Product SKU Descriptions10

Table 3-1. Component Descriptions11

Table 3-2. Tracking Module Properties.....11

Table 3-3. Inertial Measurement Specifications12

Table 3-4. Fisheye Image Sensor Properties12

Table 3-5. Module Contact Plug Details.....13

Table 3-6. Board to Board Connector Pin List.....14

Table 3-7. Tracking Module Product Labeling15

Table 3-8. Tracking Module Label Fields.....15

Table 3-9. Intel® RealSense™ Tracking Module T261 Product Identifier Code and Product Material Code15

Table 3-10. Intel® RealSense™ Tracking Module T261 Mechanical Dimensions.....16

Table 3-11. Tracking Module Storage and Operating Conditions.....16

Table 3-12. Tracking Module Power Requirements	17
Table 3-13. Intel® RealSense™ Tracking Camera T265 Mechanical Dimensions	17
Table 3-14. Max Skin Temperature.....	17
Table 3-15. Storage and Operating Conditions.....	18
Table 3-16. Product Identifier and Material Code	18
Table 4-1: Boot Device Vendor and Product IDs.....	19
Table 6-1: Intel® RealSense™ Tracking Module T261 – Component Power and TDP at Max Operating Mode.....	22
Table 6-2: Intel® RealSense™ Tracking Module T261 - Case Temperature Limits (Still Air) 22	
Table 6-3: Optical Module Cover Material Parameters	23

Revision History

Document Number	Revision Number	Description	Revision Date
572522	001	Initial Release	Jan 2019
	002	<ul style="list-style-type: none">• Table 3-3. Inertial Measurement Specifications• Figure 6-3. Center of Tracking Location• Table 4-5. Boot Device Vendor and Product IDs• 7.1 Manufacturer’s Information• 7.2 NRTL Statement	Mar 2019
	003	<ul style="list-style-type: none">• Table 3-3. Inertial Measurement Unit	Apr 2019
	004	<ul style="list-style-type: none">• Intel® RealSense™ Tracking Module T261• 4.1 Boot Device Information• Figure 6-3. T261 Module Screw Mount• Figure 6 8. Intel® RealSense™ Tracking Camera T265 Center of Tracking Location	Sept 2019

§ §

1 Description and Features

<p>Description</p> <p>Intel® RealSense™ Tracking Camera T265 and Intel® RealSense™ Tracking Module T261 are tracking capable devices based on visual and inertial sensor fusion. The assembly contains fisheye cameras, IMU module and a processing ASIC (Intel® Movidius™ Myriad™ 2 MA215x) with USB 3.0 interface to host processor SoC.</p> <p>Features</p> <ul style="list-style-type: none"> • Tracking feature using Fisheye Camera and Inertial Measurement Unit (IMU) • Intel® Movidius™ Myriad™ 2 ASIC • Middleware processed on Myriad 2 ASIC; Enabling higher CPU performance • 6DoF data streaming to host • Low latency 	<p>Usages/Markets</p> <ul style="list-style-type: none"> • Robots • Drones • Augmented Reality and Virtual Reality <p>Minimum System Requirements</p> <ul style="list-style-type: none"> • Windows* 10/Linux* • USB 3.0 (without video streaming USB 2.0 is sufficient) <p>Please check with your Intel representative for platform and OS combination supported and enablement timelines</p>
---	--

§ §

2 Introduction

2.1 Purpose and Scope of this Document

This document captures the specifications for the Intel® RealSense™ Tracking Camera T265 and Intel® RealSense™ Tracking Module T261.

2.2 Terminology

Term	Description
6DoF	6 Degrees of Freedom refers to the freedom of movement in three dimensional space. Movement such as forward/backward, up/down, left/right, pitch, roll and yaw.
Fisheye camera	Also referred as wide angle camera
FOV	Field Of View describes the angular extent of a given scene that is imaged by a camera. A camera's FOV can be measured horizontally, vertically, or diagonally
Lens	This refers to the optical component of an imager. Its purpose is to focus the incoming light rays onto the CMOS chip in the imager.
System On Chip (SoC)	Integrated circuit (IC) that integrates all components of a computer or referred in this document as host processor SOC
Imaging or Optical module	This refers to a stiffened module containing at least two imagers. The distance between the imagers, which is referred to as the baseline or intraocular spacing, is typically in the range of 20 mm to 70 mm.
IMU	Inertial Measurement Unit
B2B	Board to Board connector
IR Cut Filter	Filter designed to prevent infrared (IR) light reaching the imagers.
TBD	To Be Determined. In the context of this document, information will be available in a later revision.

2.3 Tracking Camera Technology Overview

The tracking camera and module are a computer vision solution that outputs 6DoF data to the host system for immersive experience, navigation and mapping. T265/T261 uses inputs from dual fisheye cameras (OV9282) and an IMU (BMI055) along with processing capabilities from the Movidius MA215x ASIC in order to provide the host system 6DoF poses.

2.4 Tracking System

The T265 and T261 have one main board which includes all components on a single board. T265 comprises a T261 module, an interposer card with a USB connector and a peripheral envelope. The T261 module requires an external interposer card to allow USB connection, in case it is used outside the T265 peripheral.

2.5 Intel® RealSense™ Tracking Module T261

Table below describes main components that make up the module SKU

Table 2-1. Tracking Module Product SKU Descriptions

Component	T261
Movidius Myriad 2 ASIC	✓
Fisheye Imagers	✓
IMU	✓

2.6 Intel® RealSense™ Tracking Camera T265

T265 is a tracking camera peripheral including T261, interposer card and industrial design.

§ §

3 Component Specification

3.1 Tracking Camera system Components

The device components are described in Table 3-1. The form factor module includes two fisheye image sensors, an Inertial Measurement Unit (IMU) and VPU processing ASIC.

Table 3-1. Component Descriptions

Component	Description
BMI055 IMU	Accelerometer and Gyroscope in a single package
OV9282 Fisheye Camera	Monochrome image sensor with wide field of view
Movidius MA215x	VPU Processing ASIC
Stiffener	Reinforcement housing to keep imagers aligned
Label	Manufacture and product identifier information
Other Components	IR Cut Filter, Voltage Regulators, etc.

3.2 Intel® RealSense™ Tracking Module T261

Figure 3-1. Intel® RealSense™ Tracking Module T261 Front View

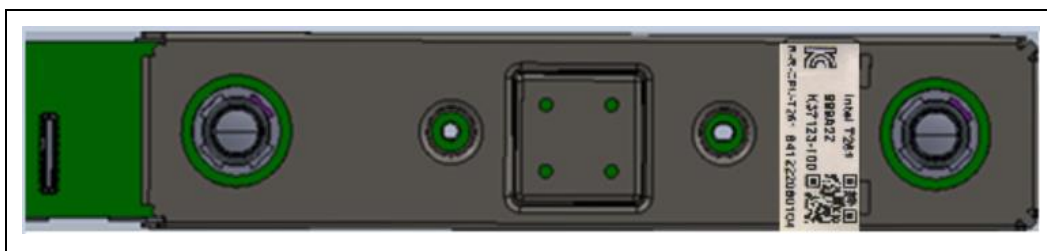

Table 3-2. Tracking Module Properties

Imaging Module	Intel® RealSense™ Tracking Module T261
Baseline (mm)	64±0.15
Left/Right Fisheye Imagers	OV9282
Shutter Type	Global
Fisheye FOV (degrees)	D:173
Module Dimensions (mm)	X=93.35 (+0.15 -0.25) Y=17.60±0.15 Z=7.13±0.30

H – Horizontal FOV, V – Vertical FOV, D – Diagonal FOV, X – Length, Y – Breadth, Z – Thickness

3.2.1 Inertial Measurement Unit

The IMU is a system-in-package for the detection of acceleration in 3 dimensions and rotations in 3 dimensions.

Table 3-3. Inertial Measurement Specifications

Parameter	Properties
Degrees of Freedom	6
Acceleration Range	±4g
Accelerometer Sample Rate	62.5Hz
Gyroscope Range	±2000 Deg/s
Gyroscope Sample Rate	200Hz

NOTES:

1. 6DoF pose data provided to host platform at a sample rate of 200Hz. The sample rate indicates average number of samples per second and might not imply a uniform distribution of the samples.

3.2.2 Fisheye Imagers

The fisheye imagers are used in the process of producing 6DoF data streamed to the host platform. The imagers provide monochrome images at 30FPS.

Table 3-4. Fisheye Image Sensor Properties

Parameter	Camera Sensor Properties
Active Pixels	848 X 800
Sensor Aspect Ratio	1.06
Format	8bit, 10-bit RAW
Filter Type	IR Cut Filter
Focus	Fixed
Shutter Type	Global Shutter
Signal Interface	MIPI CSI-2, 2 X Lanes

3.2.3 Tracking Module Connector Plug

The tracking module connector plug provides signal and power interface to the tracking module.

Table 3-5. Module Contact Plug Details

Parameter	Description	Diagram
Number of Contacts	38	
Product Name	NOVASTACK* 35-P Board-to-Board Connector	
Part Number	20708-034E-1	
Manufacturer Website	www.i-pex.com	

Figure 3-2. Board to Board Receptacle Pin Map on T261 Module

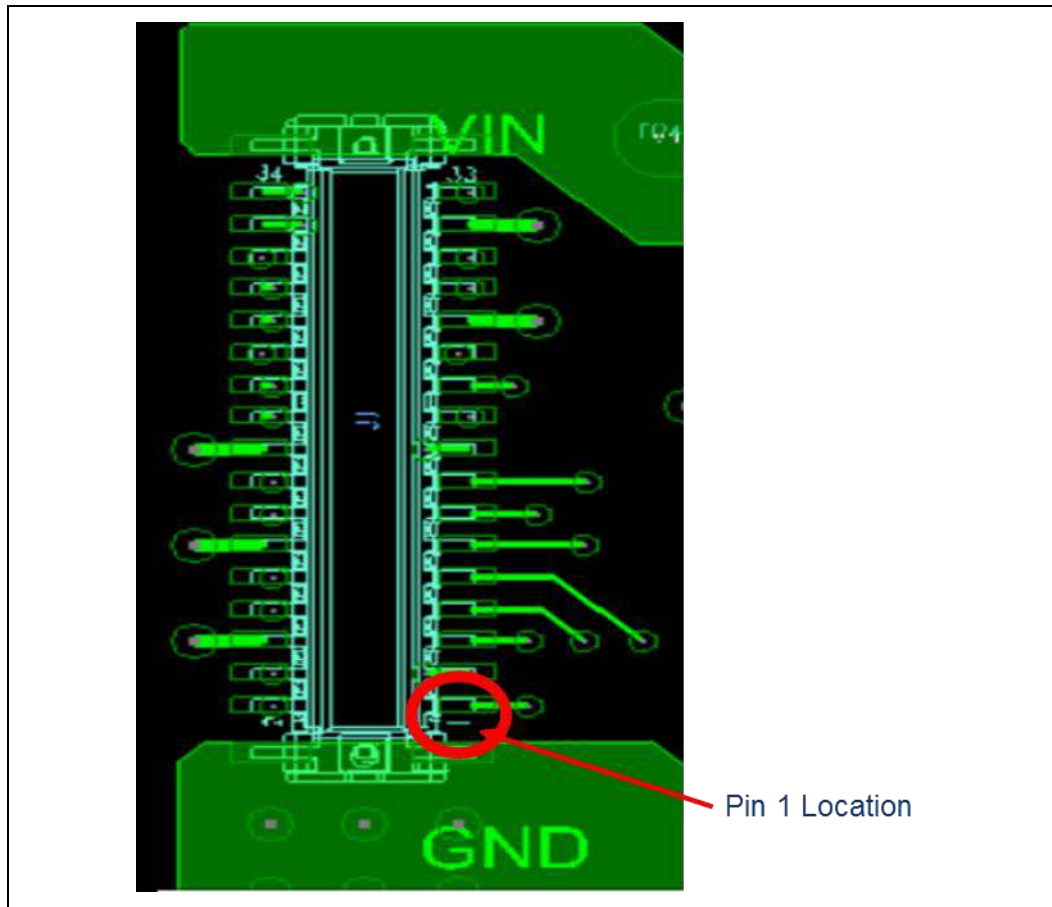

Table 3-6. Board to Board Connector Pin List

Pin Number	Description
1	Reserved
2	USB3_RX+
3	Reserved
4	USB3_RX-
5	Reserved
6	Ground
7	Reserved
8	USB3_TX+
9	Reserved
10	USB3_TX-
11	Reserved
12	Ground
13	Reserved
14	USB2+
15	Reserved
16	USB2-
17	Reserved
18	Ground
19	Reserved
20	Reserved
21	Reserved
22	Reserved
23	Reserved
24	Ground
25	Ground
26	Reserved
27	Reserved
28	Reserved
29	Reserved
30	Ground
31	Ground
32	Reserved

Pin Number	Description
33	Reserved
34	Reserved
35	VBUS (Power), VDD_5V
36	VBUS (Power), VDD_5V
37	Ground
38	Ground

3.2.4 Tracking Module Label

Table 3-7. Tracking Module Product Labeling

<p>For illustration purpose only, subject to change</p>				
		Dimension	Value	Unit
	A	Label Width	17±0.2	mm
	B	Label Height	6.9±0.2	mm
	C	Scan Code Width	5±0.2	mm
D	Scan Code Height	5±0.2	mm	
Scan Code Format XXXXXXXXXXXX000000XXXXXX-XXX				

Table 3-8. Tracking Module Label Fields

Group	Field	Description	Type
Company	Intel	Manufacturer	Static
Model Number	T261	Camera Model Number	Static
Product Assembly Number	XXXXXX	Product Identifier Code	Static
	-XXX	Manufacture Configuration Code	Dynamic
	000000	Product Material Code	Static
Serial Number	XXXXXXXXXXXX	Manufacture Unit Code	Dynamic

Table 3-9. Intel® RealSense™ Tracking Module T261 Product Identifier Code and Product Material Code

Production	Product Material Code
Intel® RealSense™ Tracking Module T261	999AXH

3.2.5 Stiffener

The stiffener maintains the precise alignment of the camera sensors and assists in subassembly rigidity. The stiffener consists of a bottom and a top plate. The stiffener is made of stainless steel grade AISI 304.

3.2.6 Mechanical Dimensions

Table 3-10. Intel® RealSense™ Tracking Module T261 Mechanical Dimensions

Dimension	Min	Nominal	Max	Unit
Width	93.1	93.35	93.5	mm
Height	17.45	17.60	17.75	mm
Depth	6.83	7.13	7.43	mm
Flatness Tolerance	-	0.25	-	mm
Weight	-	22	-	gr

3.2.7 Tracking Module Storage and Operating Conditions

Table 3-11. Tracking Module Storage and Operating Conditions

Condition	Description	Min	Max	Unit
Storage (Ambient), Not Operating	Temperature (Sustained, Controlled) ⁽¹⁾	0	40	°C
	Temperature (Short Exposure) ⁽²⁾	-30	65	°C
	Humidity	90% RH, 30°C		
Case/Stiffener Temperature (Still Air) ⁽³⁾⁽⁴⁾⁽⁵⁾	Temperature	0	55	°C

NOTE:

- (1) Controlled conditions should be used for long term storage of product.
- (2) Short exposure represents temporary max limits acceptable for transportation conditions.
- (3) Case temperature limits must be met for all operating temperatures.
- (4) Case temperature is specified for the overall tracking module
- (5) Case temperature 0° minimum and lower temperatures is non-condensing

3.2.8 Tracking Module Power Requirements

The tracking module is powered through USB VBUS power.

Table 3-12. Tracking Module Power Requirements

Parameter		Min	Nom	Max	Unit
VCC	Supply Voltage	4.5	5	5.25	V
ICC	Supply Current		300	300	mA

3.3 Intel® RealSense™ Tracking Camera T265 Device

Figure 3-3. Intel® RealSense™ Tracking Camera T265



3.3.1 Intel® RealSense™ Tracking Camera T265 Mechanical Dimensions

Table 3-13. Intel® RealSense™ Tracking Camera T265 Mechanical Dimensions

Dimension	Min	Nominal	Max	Unit
Width	107.85	108.00	108.15	mm
Height	24.35	24.50	24.65	mm
Depth	12.35	12.50	12.65	mm
Flatness Tolerance	-	0.15	-	mm
Weight	57	60	63	gr

3.3.2 Intel® RealSense™ Tracking Camera T265 Thermals

Table 3-14. Max Skin Temperature

Tracking Camera	Max Skin Temperature (25°C Ambient in Open Environment)
T265	40°C

3.3.3 Intel® RealSense™ Tracking Camera T265 Storage and Operating Conditions

Table 3-15. Storage and Operating Conditions

Condition	Description	Min	Max	Unit
Storage (Still Air), Not Operating	Temperature (Sustained, Controlled) ⁽¹⁾	0	40	°C
	Temperature (Short Exposure) ⁽²⁾	-30	65	°C
	Humidity, Non-Condensing	90% RH, 30°C		
Operating ⁽³⁾ (Still Air)	Temperature	0	35	°C

NOTES:

1. Controlled conditions should be used for long term storage of product.
2. Short exposure represents temporary max limits acceptable for transportation conditions.
3. Component case temperature limits must be met for all operating temperatures.

3.3.4 Product Identifier and Material Code

Table 3-16. Product Identifier and Material Code

Production	Product Material Code
Intel® RealSense™ Tracking Camera T265	999AXJ

§ §

4 Functional Specification

4.1 Boot Device Information

Table 4-1: Boot Device Vendor and Product IDs

Description	VID	PID
Movidius Device	03E7	2150
Intel® RealSense™ Tracking Module T261	8087	0B37
Intel® RealSense™ Tracking Camera T265	8087	0B37

1. If T261/T265 is being connected to host system via USB hub, keep in mind that T261/T265 will enter into USB enumeration protocol as soon as 5V has been provided on VBUS pin. USB protocol is handled by the Movidius MA215x device. Make sure USB hub is connected and enumerated to host system prior to power being supplied to T261/T265.
2. <1% drift observed in repeated testing in multiple use cases and environments. AR/VR use cases were tested with the T261/T265 mounted on the head in indoor living and office areas with typical indoor lighting including sunlight entering the room. Wheeled robot use cases tested with wheel odometer data integrated, in indoor office and home environments. Sufficient visibility of static tracked visual features is required, the device will not work in smoke, fog, or other conditions where the camera cannot observe visual reference points. Performance will vary across use cases and environments, the system will attempt to detect and report degraded performance but may fail to do so.

§ §

5 Software

5.1 Intel® RealSense™ Software Development Kit 2.0

Intel® RealSense™ SDK 2.0 is a cross-platform library for working with Intel® RealSense™ Tracking Camera T265 and Tracking Module T261. It is open source and available on <https://github.com/IntelRealSense/librealsense>

The SDK at a minimum includes:

- **Intel® RealSense™ Viewer** - This application can be used view, record and playback depth streams, set camera configurations and other controls.
- **Debug Tools** - These command line tools gather data and generate logs to assist in debug of camera.
- **Code Examples** - Examples to demonstrate the use of SDK to include D400 Series camera code snippets into applications.
- **Wrappers** -Software wrappers supporting common programming languages and environments such as ROS, Python, Matlab, node.js, LabVIEW, OpenCV, PCL, .NET and more

§§

6 System Integration

6.1 System Level Block Diagram

Figure 6-1. System Block Diagram

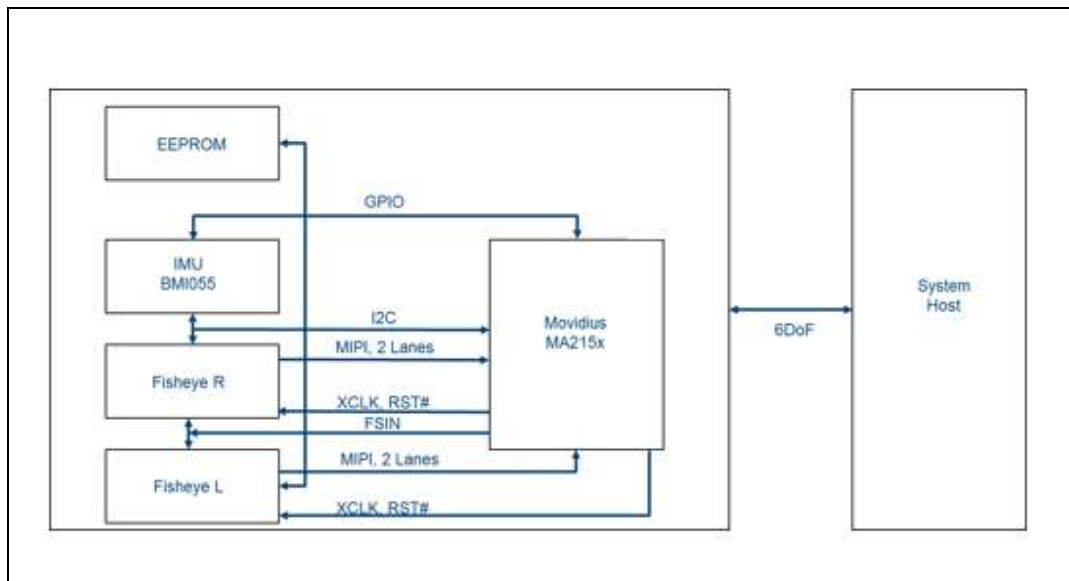

6.2 Intel® RealSense™ Tracking Module T261 Module Flex

It is critical that Intel® RealSense™ Tracking Module T261 does not experience flex during system integration or during use after integration. Micron level flexing of the module can render the calibration incorrect and will result in poor performance or nonfunctional data. It is important for system designers to isolate the module from any chassis flex the system may encounter. While the module has a reinforcement housing, the housing is not intended to counter loads from chassis flex.

6.3 Thermals

The system thermal design must ensure the component case temperature and system skin temperature limits are not exceeded.

Table 6-1: Intel® RealSense™ Tracking Module T261 – Component Power and TDP at Max Operating Mode

Component	Power	TDP	Unit
ASIC	2000	2000	mW
Fisheye Camera (Left)	134	150	mW
Fisheye Camera (Right)	134	150	mW
IMU	17	17	mW
All Components	2285	2317	mW

Table 6-2: Intel® RealSense™ Tracking Module T261 - Case Temperature Limits (Still Air)

Component	Min	Max	Unit
ASIC	0	85	°C
Fisheye Camera (Left)	0	55	°C
Fisheye Camera (Right)	0	55	°C
IMU	0	85	°C



A thermal evaluation should be completed with the Intel® RealSense™ Tracking Module T261 to validate that the system thermal solution ensures temperature limits are not exceeded.

6.3.1 Passive Heat Spreader

To minimize the need or size for an internal passive heat spreader, it is recommended that a metal chassis material with a thermal conductance greater than 20 [W/mK] and an effective thermal resistance of less than 7.7 [K/W] be used. If a plastic chassis material is used, this will generally require a passive heat spreader solution. The recommended passive heat spreader solution for a plastic chassis is as follows: 100mm x 100mm x 0.2mm graphite material with plastic chassis thickness material of 1mm.

Figure 6-2. Passive Heat Spreader

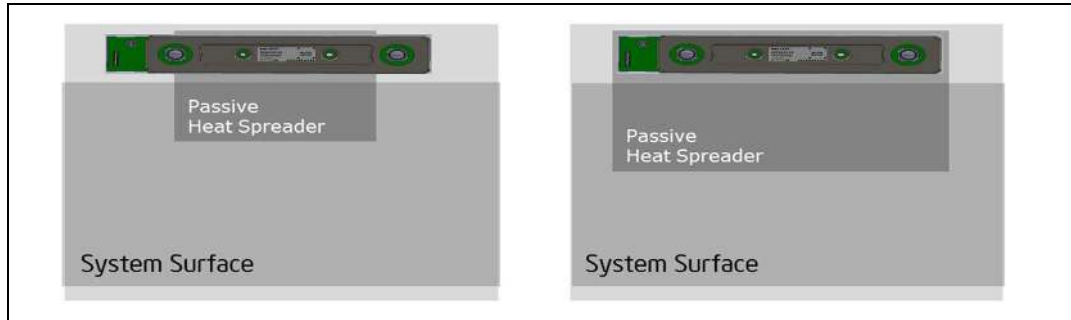

6.4 Cover Design Guidance

The T261 module components such as the fisheye camera lens must be covered to minimize dust, humidity and personal contact such as fingers to lens. All cover materials should be flat to prevent performance loss due to distortion. This is especially important for the fisheye camera sensor where distortion can significantly affect performance.

Cover materials placed over the fisheye camera sensor must be carefully selected to avoid impacting tracking performance. Distortion or reduced light sensitivity can make it difficult to track motion optically. The following recommendations should be met in cover design to support tracking performance. Other solutions can be acceptable but careful design and validation work should be done to verify a solution will perform adequately.

Table 6-3: Optical Module Cover Material Parameters

Specification	Recommendation	Notes
Hardness	6H (Design can be up to 9H with tempered glass)	Prevent Scratches
Flatness	0.05mm	Minimize Distortion
Minimum Gap Distance From T261 Lens to Cover Material	0.1mm (min) 0.6mm (max)	Lens height tolerance ± 0.2 mm should be considered
Fisheye FOV with Cover Window	170°	Keep FE FOV under all mechanical and optical design tolerances
Cover Window Coatings	Dual Side Anti-Reflect Coating	Avoid Reflections; Other coating material might have an effect on performance and should be evaluated.

Total Window Transmission Wavelength Range	400 – 900nm	
	Incident Half Angle	Typical Trans
	0-50°	97%
	60°	95%
	70°	85%
	80°	65%
	85°	45%
Cover Window Overall Tilt Tolerance by System Integrator	$\pm 0.5^\circ$	

6.5 Mounting Guidance

6.5.1 Screw Mount

The Intel® RealSense™ Tracking Module T261 module incorporates a screw hole for module mounting. The module should be mounted on a large heat sink or a heat dissipating structure element using M1.4 screw at the screw hole and thermal adhesive in the middle region (ex: 3M 8810). Thermal interface material should be used on backside region of ASIC and two fisheye imagers between camera module and heat sink or heat dissipating structure element for thermal transfer.

Figure 6-3. T261 Module Screw Mount

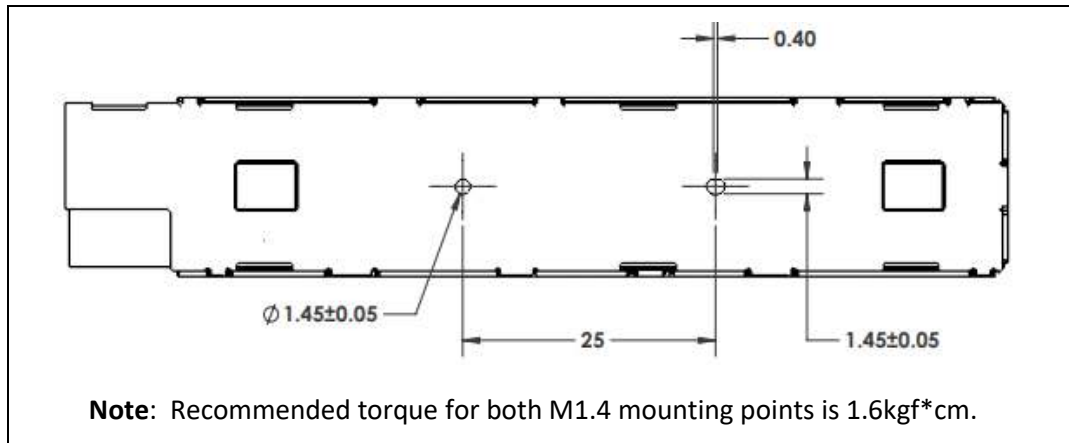

6.5.2 Occlusion Avoidance

In order to improve quality of the 6DoF tracking capability of the Intel® RealSense™ Tracking Module T261 device, it is recommended that the mounting solution, whether integrated into HMD or used as a peripheral attachment, avoid covering, blocking or occluding the camera FOV. Below are images, depictions of possible mounting positions and mounting faults are examples for the VR segment. Other segments for T261 will have its own challenges that may not be depicted below.

Figure 6-4. Example for VR: HMD Positioning for Controller

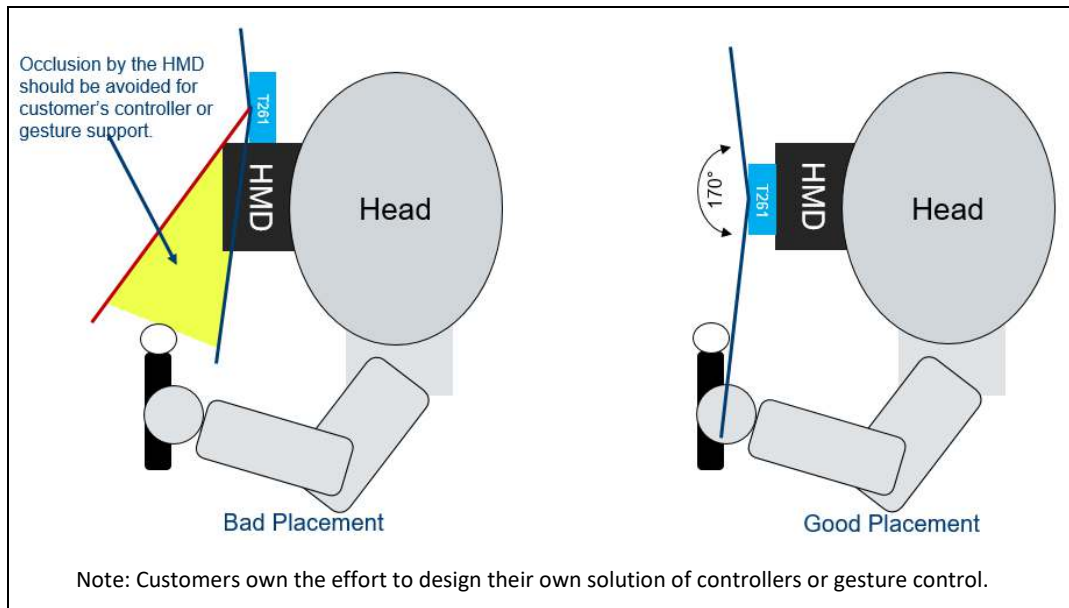

Figure 6-5. Example for VR: Front Mounting Advantages

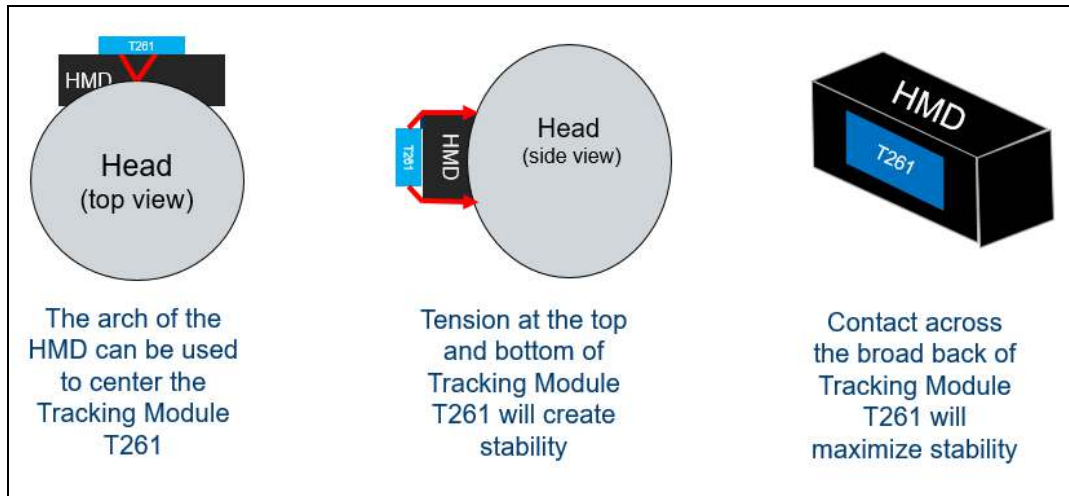
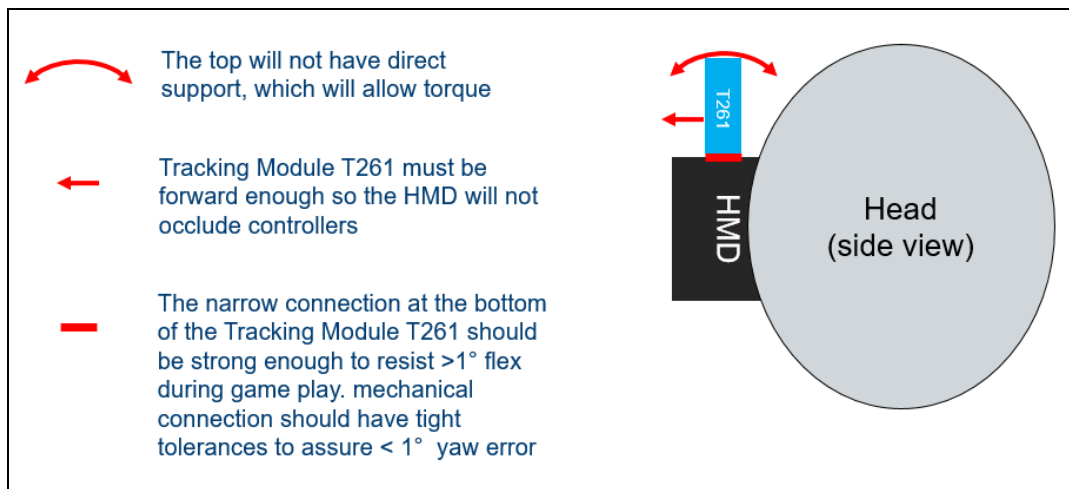

Figure 6-6. Example for VR: Top Mounting Challenges



6.6 Gaskets

Gaskets are recommended for providing optical isolation and dust protection. However, gaskets can impede FOV and place unwanted stress on the module or the individual sensor lens holders.

Gasket static force can deform the cosmetic baffle/lens holder resulting in poor image quality and permanent damage to the camera. Gaskets placed on the module stiffener

can transfer chassis flex into the camera module causing loss of data. Gasket thickness has a large effect on the static force applied to the module surface. The thinner the seal, the greater the static force applied. Once the gasket is compressed, the static force will increase exponentially.

6.6.1 Dust Protection

Dust particles can accumulate over the camera lenses which can be visually unappealing and degrade image quality.

6.7 Center of Tracking Location

The users of the tracking module and tracking camera must take into consideration the location of tracking as it pertains to the PCB inside chassis and the relationship this location has with respect to the overall system. The center of tracking corresponds to the center location between the right and left imagers on the PCB. The information in the figures below show the different mechanical specifics that help in understanding center of tracking. The center of tracking information also pertains to the coordinate system which will be discussed in future section in this document.

Figure 6-7. Intel® RealSense™ Tracking Module T261 Center of Tracking Location

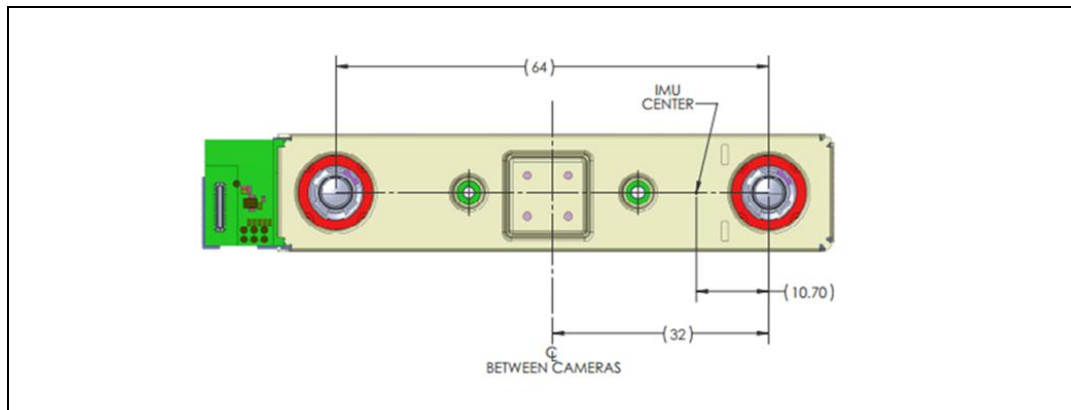
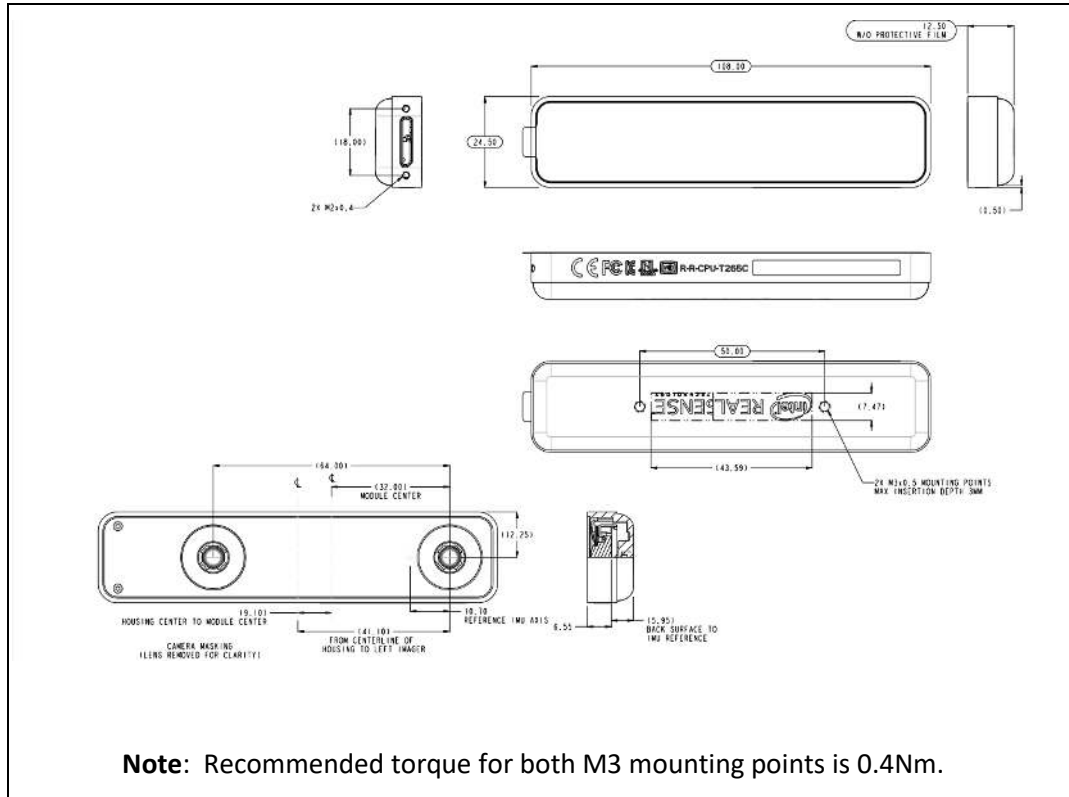
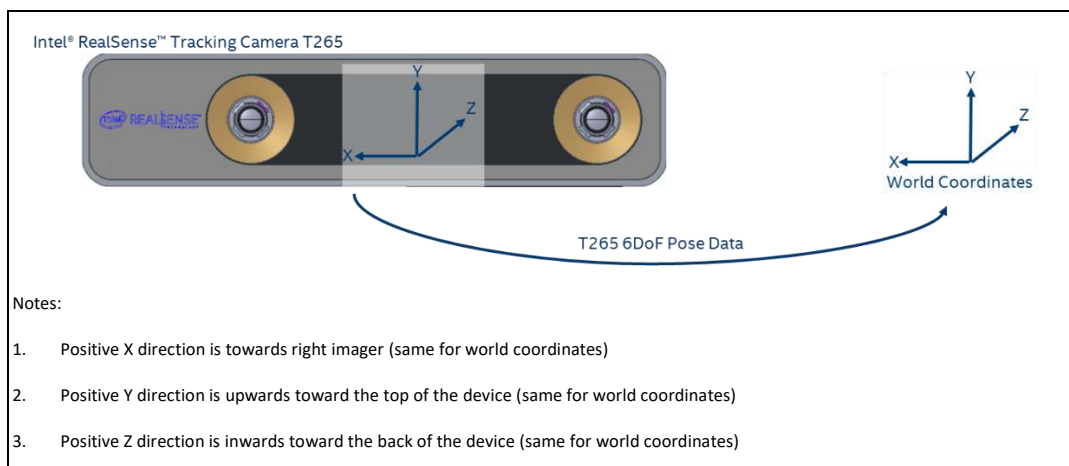

Figure 6-8. Intel® RealSense™ Tracking Camera T265 Center of Tracking Location



6.8 Tracking System Coordinate System

Figure 6-9. Tracking System Coordinate System



4. Coordinate system is the same for both the Intel® RealSense™ Tracking Module T261 and Intel® RealSense™ Tracking Camera T265

§ §

7 Product Regulatory



System integrators should refer to their respective regulatory and compliance owner to finalize regulatory requirements for a specific geography.



Do not power on the product if any external damage was observed.
Do not try to update camera firmware that is not officially released for specific camera module SKU and revision.

7.1 Manufacturer's Information

Manufactured by Intel Corporation
Attn: Corp. Quality
2200 Mission College Blvd., Santa Clara, CA 95054 USA

EU Single Place of Contact:
Attn: Corp Quality
Intel Deutschland GmbH
Am Campeon 10-12
Neubiberg, 85579 - Germany

7.2 NRTL Statement

For the US and Canada market, this product has been tested and certified by Nemko, and found to be compliant with all applicable requirements of the specifications below.

UL 60950-1 2nd Edition, CAN/CSA C22.2 No. 60950-1-07, Information Technology Equipment – Safety – Part 1: General Requirements

Nemko is a Nationally Recognized Testing Laboratory (NRTL), recognized by US Occupational Safety and Health Administration (OSHA) as qualified to perform safety testing and certifications covered within its scope of recognition.

Figure 7-1. NRTL Certification

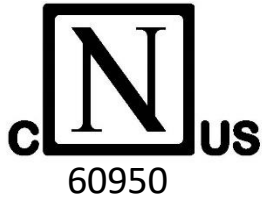

<https://www.nemko.com/certification/product-certification/certificates>

Certificate #: NA201911024 (for T265 only)

7.3 Ecology Compliance

7.3.1 RoHS Declaration

China RoHS Declaration

产品中有毒有害物质的名称及含量
Hazardous Substances Table

部件名称 Component Name	有毒有害物质或元素 Hazardous Substance					
	铅 Pb	汞 Hg	镉 Cd	六价铬 Cr (VI)	多溴联苯 PBB	多溴二苯醚 PBDE
相机 Camera	○	○	○	○	○	○
印刷电路板组件 Printed Board Assemblies	X	○	○	○	○	○

○：表示该有毒有害物质在该部件所有均质材料中的含量均在 GB/T 26572 标准规定的限量要求以下。

○：Indicates that this hazardous substance contained in all homogeneous materials of such component is within the limits specified in GB/T 26572.

×：表示该有毒有害物质至少在该部件的某一均质材料中的含量超出 GB/T 26572 标准规定的限量要求。

×：Indicates that the content of such hazardous substance in at least a homogeneous material of such component exceeds the limits specified in GB/T 26572.

对销售之日的所售产品, 本表显示我公司供应链的电子信息技术产品可能包含这些物质。注意：在所售产品中可能会也可能不会含有所有所列的部件。

除非另外特别的标注, 此标志为针对所涉及产品的环保使用期限标志。某些可更换的零部件可能会有一个不同的环保使用期限(例如, 电池单元模块)。

此环保使用期限只适用于产品在产品手册中所规定的条件下工作。



The Environment-Friendly Use Period (EFUP) for all enclosed products and their parts are per the



In the European Union, this symbol indicates that this product including battery must not be disposed of with household waste. It is your responsibility to hand it over to a designated collection point for the recycling of waste electrical and electronic equipment. For more information, please contact your local waste collection center or the point of purchase of this product.

X-ON Electronics

Largest Supplier of Electrical and Electronic Components

Click to view similar products for [Cameras & Camera Modules](#) category:

Click to view products by [Intel](#) manufacturer:

Other Similar products are found below :

[FH-SC](#) [LI-OV9712-USB-M12](#) [CAMOV5645](#) [73-540-420I](#) [Web Camera module 5.0M pixel](#) [LI-IMX424-GMSL2-070H](#) [FIT0729](#) [AWC-002](#)
[LI-AR0231-GMSL2-CFM-176H-010](#) [LI-USB30-IMX490-GW5400-GMSL2-065H](#) [FIT0730](#) [73-951-0046](#) [73-954-0001T](#) [73-961-0005](#) [1202](#)
[1203](#) [73-961-0003](#) [73-961-0012](#) [107139](#) [107115](#) [107149](#) [107142](#) [82535IVCHVM](#) [107140](#) [107113](#) [107112](#) [107141](#) [107147](#) [107148](#) [107110](#)
[107150](#) [107145](#) [107111](#) [OKY3553](#) [10299](#) [10300](#) [613](#) [82637BRPLHV](#) [EP-DCINTELD-415](#) [1386](#) [4321](#) [4561](#) [NEON-203B-JNX Starter Kit,](#)
[2M, 30fps](#) [NEON-202B-JT2-X Starter Kit, 1.9M, 60fps](#) [NEON-203B-JT2-X Starter Kit, 2M, 30fps](#) [NEON-204B-JT2-X Starter Kit, 5M, 14fps](#)
[NEC_B&W_SGA_FOV120_F4.0](#) [AD-3DSMARTCAM1-PRZ](#) [43203](#) [104002](#)