

Intel® RAID Smart Battery AXXRSBBU7 User's Guide

A Guide for Technically Qualified Assemblers of Intel® Identified Subassemblies/Products

Intel Order Number: E70472-001



Warranty Notice: Adding a battery onto an Intel® RAID controller will limit the warranty of this product. Returns determined to be caused by battery installation damage, stripped screws, or other damage resulting from the battery installation will not be covered. ESD damage to the board will also not be covered by the warranty.

The warranty on the Intel® RAID Smart Battery AXXRSBBU7 is one year.

Disclaimer

Information in this document is provided in connection with Intel® products. No license, express or implied, by estoppel or otherwise, to any intellectual property rights is granted by this document. Except as provided in Intel's Terms and Conditions of Sale for such products, Intel assumes no liability whatsoever, and Intel disclaims any express or implied warranty, relating to sale and/or use of Intel products including liability or warranties relating to fitness for a particular purpose, merchantability, or infringement of any patent, copyright or other intellectual property right. Intel products are not designed, intended or authorized for use in any medical, life saving, or life sustaining applications or for any other application in which the failure of the Intel product could create a situation where personal injury or death may occur. Intel may make changes to specifications and product descriptions at any time, without notice.

Intel is a registered trademark of Intel Corporation or its subsidiaries in the United States and other countries.

* Other names and brands may be claimed as the property of others.

Copyright © 2009 Intel Corporation. All rights reserved.

Copyright © 2007 - 2009 LSI Corporation. All rights reserved.

Safety Information

Important Safety Instructions

Read all caution and safety statements in this document before performing any of the instructions. See also Intel Server Boards and Server Chassis Safety Information on the *Intel® Server Deployment Toolkit 2.0 CD* and/or at <http://support.intel.com/support/motherboards/server/sb/cs-010770.htm>.

Wichtige Sicherheitshinweise

Lesen Sie zunächst sämtliche Warn- und Sicherheitshinweise in diesem Dokument, bevor Sie eine der Anweisungen ausführen. Beachten Sie hierzu auch die Sicherheitshinweise zu Intel-Serverplatinen und Servergehäusen auf der *Intel® Server Deployment Toolkit 2.0 CD* oder unter <http://support.intel.com/support/motherboards/server/sb/cs-010770.htm>.

Consignes de sécurité

Lisez attention toutes les consignes de sécurité et les mises en garde indiquées dans ce document avant de suivre toute instruction. Consultez Intel Server Boards and Server Chassis Safety Information sur le *Intel® Server Deployment Toolkit 2.0 CD* ou bien rendez-vous sur le site <http://support.intel.com/support/motherboards/server/sb/cs-010770.htm>.

Instrucciones de seguridad importantes

Lea todas las declaraciones de seguridad y precaución de este documento antes de realizar cualquiera de las instrucciones. Vea Intel Server Boards and Server Chassis Safety Information en el *Intel® Server Deployment Toolkit 2.0 CD* y/o en <http://support.intel.com/support/motherboards/server/sb/cs-010770.htm>.

重要安全指导

在执行任何指令之前，请阅读本文件中的所有注意事项及安全声明。并参阅 <http://support.intel.com/support/motherboards/server/sb/CS-010770.htm> 上的 *Intel Server Boards and Server Chassis Safety Information*（《Intel 服务器主板与服务器机箱安全信息》）。

Warnings

Heed safety instructions: Before working with your server product, whether you are using this guide or any other resource as a reference, pay close attention to the safety instructions. You must adhere to the assembly instructions in this guide to ensure and maintain compliance with existing product certifications and approvals. Use only the described, regulated components specified in this guide. Use of other products / components will void the UL listing and other regulatory approvals of the product and will most likely result in noncompliance with product regulations in the region(s) in which the product is sold.

System power on/off: The power button DOES NOT turn off the system AC power. To remove power from system, you must unplug the AC power cord from the wall outlet. Make sure the AC power cord is unplugged before you open the chassis, add, or remove any components.

Hazardous conditions, devices and cables: Hazardous electrical conditions may be present on power, telephone, and communication cables. Turn off the server and disconnect the power cord, telecommunications systems, networks, and modems attached to the server before opening it. Otherwise, personal injury or equipment damage can result.

Electrostatic discharge (ESD) and ESD protection: ESD can damage disk drives, boards, and other parts. We recommend that you perform all procedures in this chapter only at an ESD workstation. If one is not available, provide some ESD protection by wearing an antistatic wrist strap attached to chassis ground any unpainted metal surface on your server when handling parts.

ESD and handling boards: Always handle boards carefully. They can be extremely sensitive to ESD. Hold boards only by their edges. After removing a board from its protective wrapper or from the server, place the board component side up on a grounded, static free surface. Use a conductive foam pad if available but not the board wrapper. Do not slide board over any surface.

Installing or removing jumpers: A jumper is a small plastic encased conductor that slips over two jumper pins. Some jumpers have a small tab on top that you can grip with your fingertips or with a pair of fine needle nosed pliers. If your jumpers do not have such a tab, take care when using needle nosed pliers to remove or install a jumper; grip the narrow sides of the jumper with the pliers, never the wide sides. Gripping the wide sides can damage the contacts inside the jumper, causing intermittent problems with the function controlled by that jumper. Take care to grip with, but not squeeze, the pliers or other tool you use to remove a jumper, or you may bend or break the pins on the board.

Table of Contents

Safety Information	iii
Important Safety Instructions	iii
Wichtige Sicherheitshinweise	iii
Consignes de sécurité	iii
Instrucciones de seguridad importantes	iii
Warnings	v
Chapter 1: About the Intel® RAID Smart Battery AXXRSBBU7	1
Chapter 2: Installing the Hardware	3
Remote Extender Board (REB)	4
Remote Battery Connecting Cables	4
Important Pre-installation Considerations	5
Installing the Intel® RAID Smart Battery AXXRSBBU7	5
Removing the RAID Controller	5
Installing the Intel® RAID Smart Battery AXXRSBBU7	6
Installing the Intel® RAID Controller in the Server System	10
Chapter 3: Monitoring Battery Backup	13
Monitoring the BBU with the Intel® RAID BIOS Configuration Utility	13
Using Intel® RAID Web Console 2	14
Chapter 4: Replacing Battery Backup Units	17
Disposing of Battery Backup Units	17
Chapter 5: Battery Backup Unit Specifications	19
Battery Life and Data Retention Time	19

List of Tables

Table 1. Cable Compatability	4
Table 2. BBU Specifications.....	19

List of Figures

Figure 1. Top and Bottom View of the Intel® RAID Smart Battery AXXRSBBU7.....	3
Figure 2. Remote Extender Board.....	4
Figure 3. Installing Directly on the Intel® RAID Controller.....	7
Figure 4. Mounting the Battery on a RAID Controller.....	7
Figure 5. Installing the Plastic Standoff on the REB.....	8
Figure 6. Installing the REB onto the RAID Controller	9
Figure 7. Connecting the Cables.....	10
Figure 8. Seating the RAID Card into PCI Express* Slot	11
Figure 9. Monitoring the Battery with Intel® RAID BIOS Console	14
Figure 10. BBU information in Intel® RAID Web Console 2	15

1 About the Intel® RAID Smart Battery AXXRSBBU7

Intel® RAID (Redundant Array of Inexpensive Disks) Controllers and Intel® Integrated Server RAID Modules provide reliability, high performance, and fault-tolerant disk subsystem management. A complete fault-tolerant strategy requires protection of all data, including the unwritten cached data in the RAM cache. If power is lost, the data in the RAM cache is lost. To avoid data loss, a battery can be added to supply power to the RAID RAM during an AC power outage or if the AC power cord is removed.

A battery backup unit (BBU) protects the integrity of the cached data on Intel® RAID Controllers by providing backup power if there is a complete AC power failure or a brief power outage. The Intel® RAID Smart Battery Backup Unit provides an inexpensive alternative to using an uninterruptible power supply (UPS) or it can act as a second level of fault tolerance when used with a UPS.

The cache memory available on Intel® RAID controllers can improve the overall system performance. Writing data to the controller's cache memory is much faster than writing it to a storage device. Write operations appear to complete very quickly at the software application level. The Intel® RAID Controller writes the cached data to the storage device when system activity is low or when the cache is getting full. The risk of using write-back cache is that the cached data can be lost if the AC power fails before it is written to the storage device. This risk factor is eliminated when the Intel® RAID Controller has a BBU installed.

The Intel® RAID Smart Battery Backup Unit monitors the voltage level of the DRAM modules installed on the Intel® RAID Controller. If the voltage drops below a predefined level, the battery backup module switches the memory power source from the controller to the battery pack attached to the Intel® RAID Smart Battery Backup Unit. As long as the voltage level stays below the predefined value, the battery backup module provides power for memory. When the voltage level returns to an acceptable level, the module switches the power source back to the Intel® RAID Controller, and all pending writes to storage devices are completed without losing any data.

The battery backup module has built-in functionality to charge the battery pack automatically and to communicate battery status information such as voltage, temperature, and current to the host computer system.

The Intel® RAID Smart Battery AXXRSBBU7 is a smart battery backup module and uses lithium-ion (Li-Ion) battery technology. It is compatible with a backup auxiliary power source. The battery is charged automatically.

2 Installing the Hardware

The battery pack is mounted on a daughter card, which is then attached to the RAID controller either locally or remotely. **Figure 1** displays the top and bottom views of the Intel[®] RAID Smart Battery AXXRSBBU7. The J5 connector (see letter “B” for the location of this connector) plugs into the Intel[®] RAID Controller. The J2 connector (see letter “C” for the location of this connector) supports remote connection to an Intel[®] RAID Controller. Only the top side of the daughter card is visible after it is installed on the RAID controller.

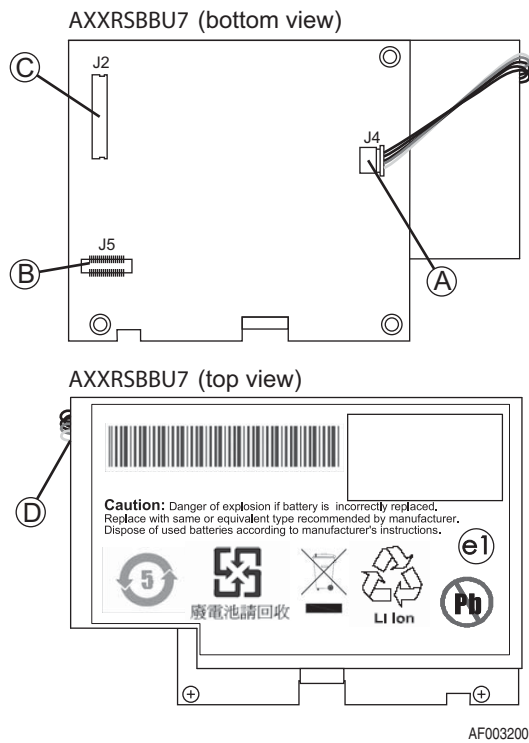

- A. J4 Battery Pack Harness Connector
- B. J5 Board-to-board Connector
- C. J2 Remote BBU Connector
- D. Battery Pack Harness

Figure 1. Top and Bottom View of the Intel[®] RAID Smart Battery AXXRSBBU7

Remote Extender Board (REB)

The REB component is a small daughter card that mounts directly to the base controller through the board-to-board connector J2 and is secured by one screw. It provides a 20-pin battery connector J1 for remote battery installation support for base controllers that do not have a 20-pin connector on the controller. The REB is included in the RAID controller product kit.

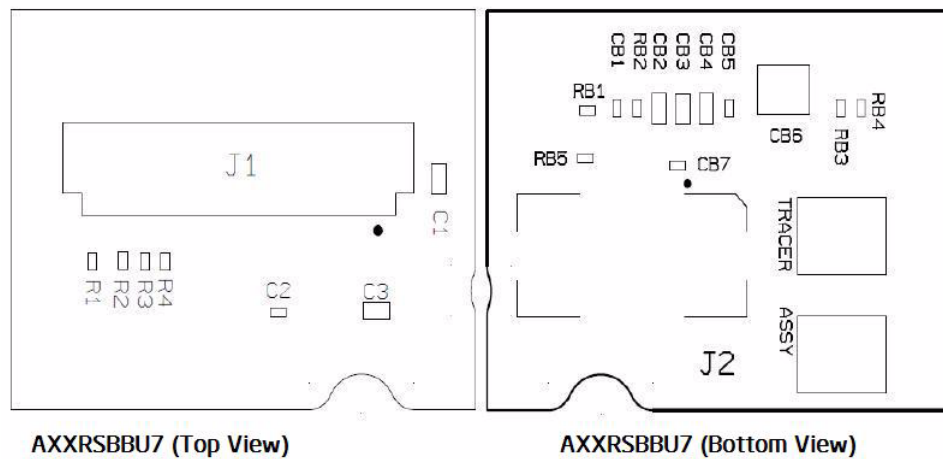

Figure 2. Remote Extender Board

Remote Battery Connecting Cables

A 20 inch 20-pin cable is provided in the battery kit to remotely connect the Intel® RAID Smart Battery AXXRSBBU7 to the RAID controller, or to a REB which is mounted on the RAID controller. Intel recommends mounting the battery remotely from the RAID controller when possible to provide additional cooling.

Table 1. Cable Compatibility

Intel® RAID Controller or Server System	20-inch Cable
Intel® RAID Controller RS2BL080	X (Requires the REB)
Intel® RAID Controller RS2BL040	X (Requires the REB)
Intel® RAID Controller RS2PI009	X

Important Pre-installation Considerations

Warning: Always ground yourself and/or use a ground strap before touching the RAID controller or the Intel® RAID Smart Battery AXXRSBBU7. Perform all installation work at an ESD-safe workstation. Use an ESD-safe Phillips* screwdriver set to a maximum torque of 2.25 inch-pounds, and be sure the screwdriver is centered in the screw to avoid damaging the screw head. If you exceed the maximum torque specification, you may damage the board, connectors, or screws, and you will void the warranty of the board.

The batteries in the Intel® RAID Smart Battery AXXRSBBU7 must charge for at least six hours during fast charge, under normal operating conditions.

To protect your data, Intel recommends that you set the RAID Controller Write Policy to write-through until the battery unit is fully charged. When the battery unit is charged, you can change the Write Policy to write-back to take advantage of the performance improvements of data caching.

The maximum ambient temperature for the battery pack is 40° C.

Note: The temperature of the battery pack is generally 15-20 degrees higher than the ambient temperature during fast charge. Therefore, to complete the fast charge cycle, ambient temperature should be less than 40° C. If the ambient temperature exceeds 40° C, the fast charge cycle will terminate prematurely, thus preventing the battery pack from reaching a fully charged state. Intel recommends mounting the battery remotely from the RAID controller when possible to provide additional cooling.

Installing the Intel® RAID Smart Battery AXXRSBBU7

To install the Intel® RAID Smart Battery AXXRSBBU7 on the Intel® RAID Controller, you must perform the following steps:

1. Remove the RAID Controller if it is already installed in the server system. For information, see [“Removing the RAID Controller” on page 5](#).
2. Install the Intel® RAID Smart Battery AXXRSBBU7 on the RAID Controller using one of the following methods:
 - Install directly through the board-to-board connector. For information, see [“Installing Directly on the RAID Controller” on page 6](#).
 - Set up a remote connection through the remote BBU connector. For information, see [“Setting up a Remote Connection to the RAID Controller” on page 8](#).
3. Install the RAID Controller in the server system. For information, see [“Installing the Intel® RAID Controller in the Server System” on page 10](#).

Removing the RAID Controller

If the RAID controller is already installed in a computer, do the following to remove it before you install the Intel® RAID Smart Battery AXXRSBBU7:

1. Shut down the computer, turn off the power, and unplug the power cord(s).

2. Remove the chassis cover and ground yourself before touching the RAID controller. Carefully unplug all cables connected to the RAID controller. Press the silver spring at the connector end of the data cables to make sure the two tiny catches release.
3. Carefully remove the RAID controller from the server board. For more information on removing add-in cards, refer to the server board documentation.
4. Place the RAID controller on a flat, clean, static-free surface.

Installing the Intel® RAID Smart Battery AXXRSBBU7

You can either directly connect the Intel® RAID Smart Battery AXXRSBBU7 to the RAID Controller or you can set up a remote connection to the RAID Controller.

Installing Directly on the RAID Controller

To install the Intel® RAID Smart Battery AXXRSBBU7 on the RAID Controller through the J5 board-to-board connector (daughter card), do the following:

1. Ground yourself, and remove the Intel® RAID Smart Battery AXXRSBBU7 from the package.
2. Verify that the wire from the battery is connected to the circuit board. If it is not connected, insert the battery pack harness connector at the end of the colored wires into the 5-pin J4 connector (see letter “A” in [Figure 1](#)) on the back side of the battery.
3. Make sure the three standoffs, six screws, and Phillips* screwdriver are easily accessible during the following steps.
4. Remove the protective metal cover from the battery connector on the Intel® RAID Controller (connector JT3 on the Intel® RAID Controller RS2BL080).

- Align the battery for your specific RAID controller by placing the Intel® RAID Controller RS2BL080 with the components facing up (see Figure 3).

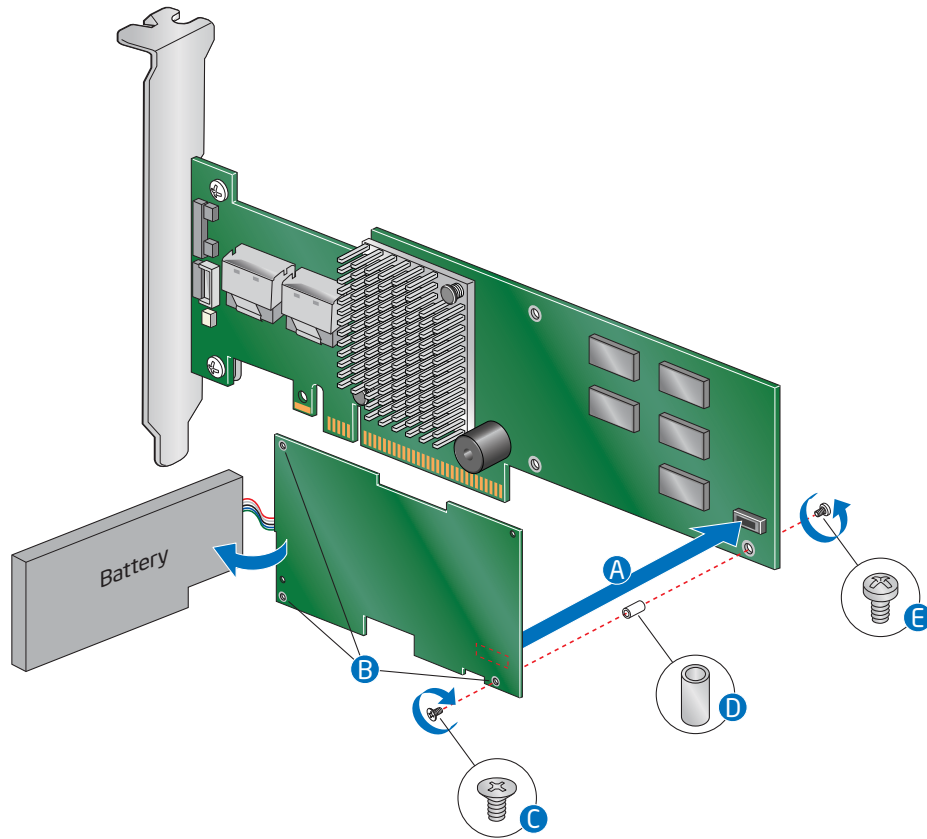

AF003236

Figure 3. Installing Directly on the Intel® RAID Controller

- Hold the controller such that the battery side is up and the three screw holes are aligned.

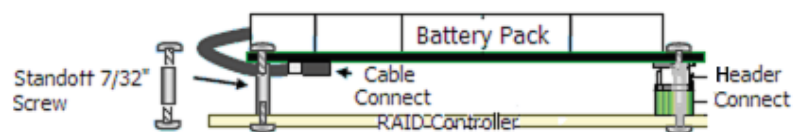

Figure 4. Mounting the Battery on a RAID Controller

- Insert the standoffs into the three screw holes, between the two cards.
- Carefully press the Intel® RAID Smart Battery AXXRSBBU7 onto the RAID controller, so that the two connectors shown above in Figure 4 are firmly joined.

Note: On the Intel® RAID Controller RS2BL080, use the JT3 connector.

- Attach the Intel® RAID Smart Battery AXXRSBBU7 to the RAID controller using the six Phillips* (2-56) screws provided. The standoffs are threaded at both ends and

a 2-56 screw goes into each end. Place three screws from the battery side, and three from the RAID controller side.

Caution: Center the screwdriver carefully to avoid stripping the screw head. Do not over-tighten the screws. The maximum recommended torque is 2.25-inches per pound.

Setting up a Remote Connection to the RAID Controller

To install the Intel® RAID Smart Battery AXXRSBBU7 on the RAID Controller through the J2 Remote BBU connector, do the following:

1. Ground yourself, and remove the Intel® RAID Smart Battery AXXRSBBU7 from the package.
2. Install the plastic standoff to the REB.

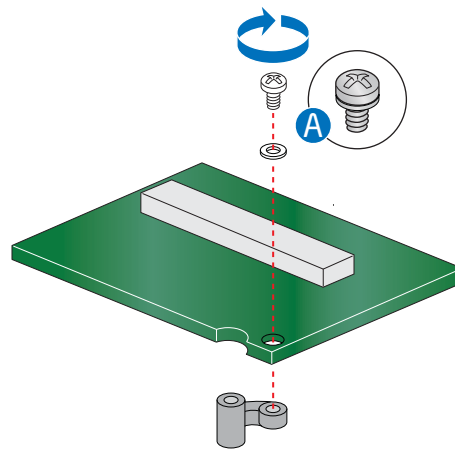

AF003238

Figure 5. Installing the Plastic Standoff on the REB

3. Install the Remote Extension Board (REB) onto the RAID controller's battery connector (JT3 on the RS2BL080).

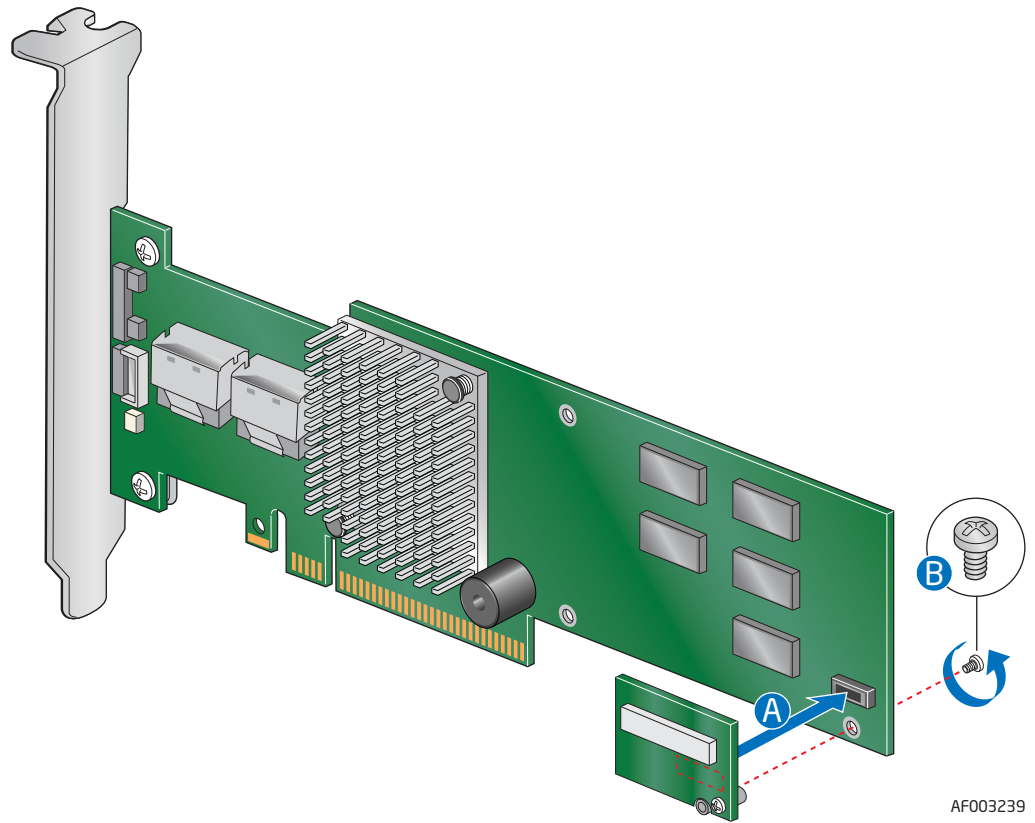
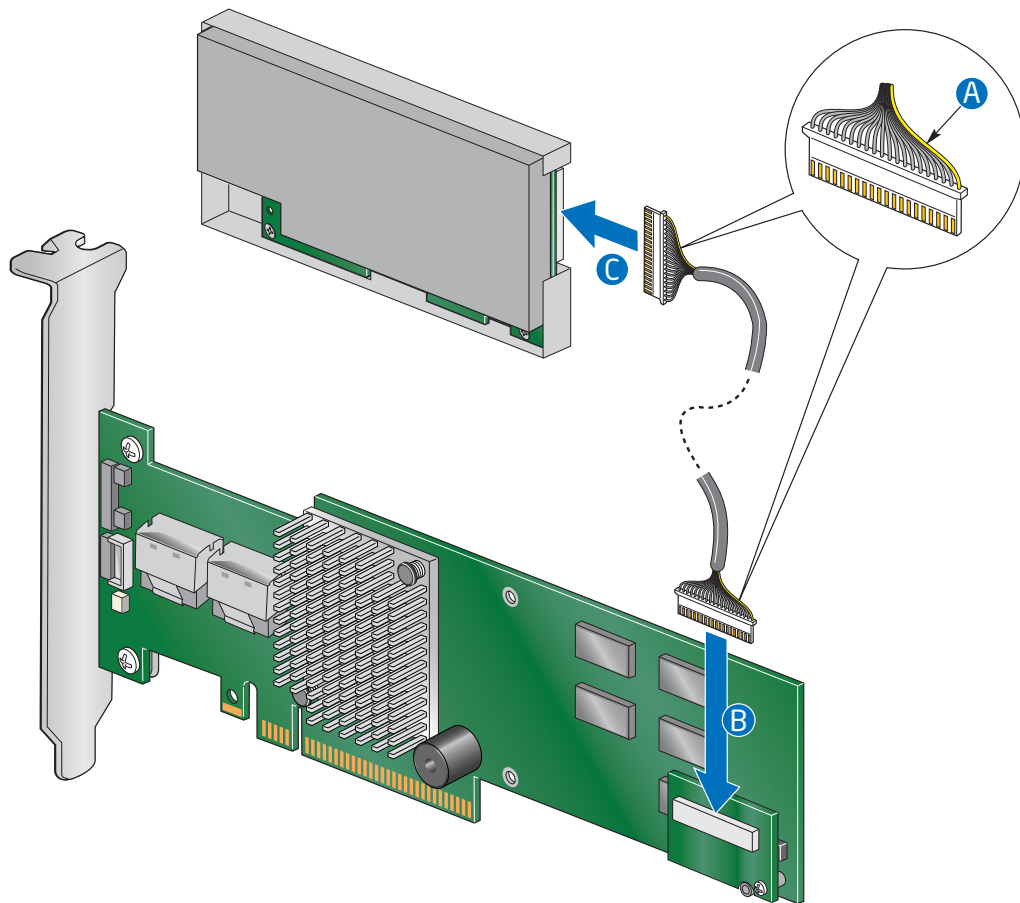

Figure 6. Installing the REB onto the RAID Controller

4. Verify that the wire from the battery is connected to the circuit board. If it is not connected, insert the battery pack harness connector at the end of the colored wires into the 5-pin J4 connector (see letter “A” in [Figure 1](#)) on the back side of the battery.

Note: Please carefully observe how the battery cable connectors are keyed and to avoid asserting unnecessary force when plugging in the cable.



AF003241

Figure 7. Connecting the Cables

Installing the Intel® RAID Controller in the Server System

To install the Intel® RAID Controller back into the server system, do the following:

1. Align the RAID controller with the PCI Express* slot.
2. Press down gently, but firmly, to ensure that the RAID controller is properly seated in the slot. The bottom edge of the RAID controller must be flushed with the slot.

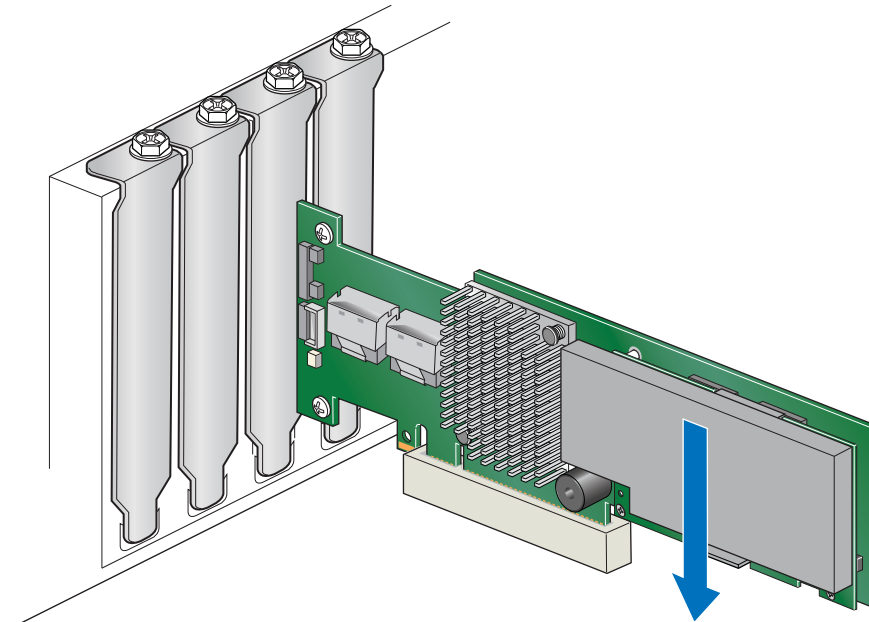

AF003240

Figure 8. Seating the RAID Card into PCI Express* Slot

Caution: *Never apply pressure to the Intel® RAID Smart Battery AXXRSBBU7 when you insert the RAID controller. Only press down on the top edge of the RAID controller.*

3. Attach the cables, as needed, to the connectors on the Intel® RAID controller.
4. Replace the chassis cover and reattach the power cord(s).

3 Monitoring Battery Backup

Multiple utilities are available to display and configure the BBU information, including the recharge count. When you replace a BBU, you should reset this counter to zero. Intel recommends that you replace the BBU once a year or after 500 recharge cycles, whichever comes first.

Note: *This chapter describes only the BBU-related features of the utility programs. For complete information on these utilities, see the Intel® RAID Software User's Guide.*

Monitoring the BBU with the Intel® RAID BIOS Configuration Utility

The Intel® RAID BIOS Console can be used to configure disk arrays and logical drives. It is independent of the operating system and can be accessed at server start up by pressing <Ctrl>+<G>.

To view the BBU information, do the following:

1. At boot, press <Ctrl> + <G> when prompted.
2. Once the Intel® RAID BIOS Console loads and the main menu appears, choose Adapter Properties.
3. Click Next to view the second Adapter Properties screen.
4. In the Battery Backup field at the top left of the Adapter Properties screen, click Present.
5. The Battery Module screen appears, as shown in [Figure 9](#). This screen contains the following information:
 - Battery information
 - Design information
 - Capacity information
 - Auto Learn properties and settings

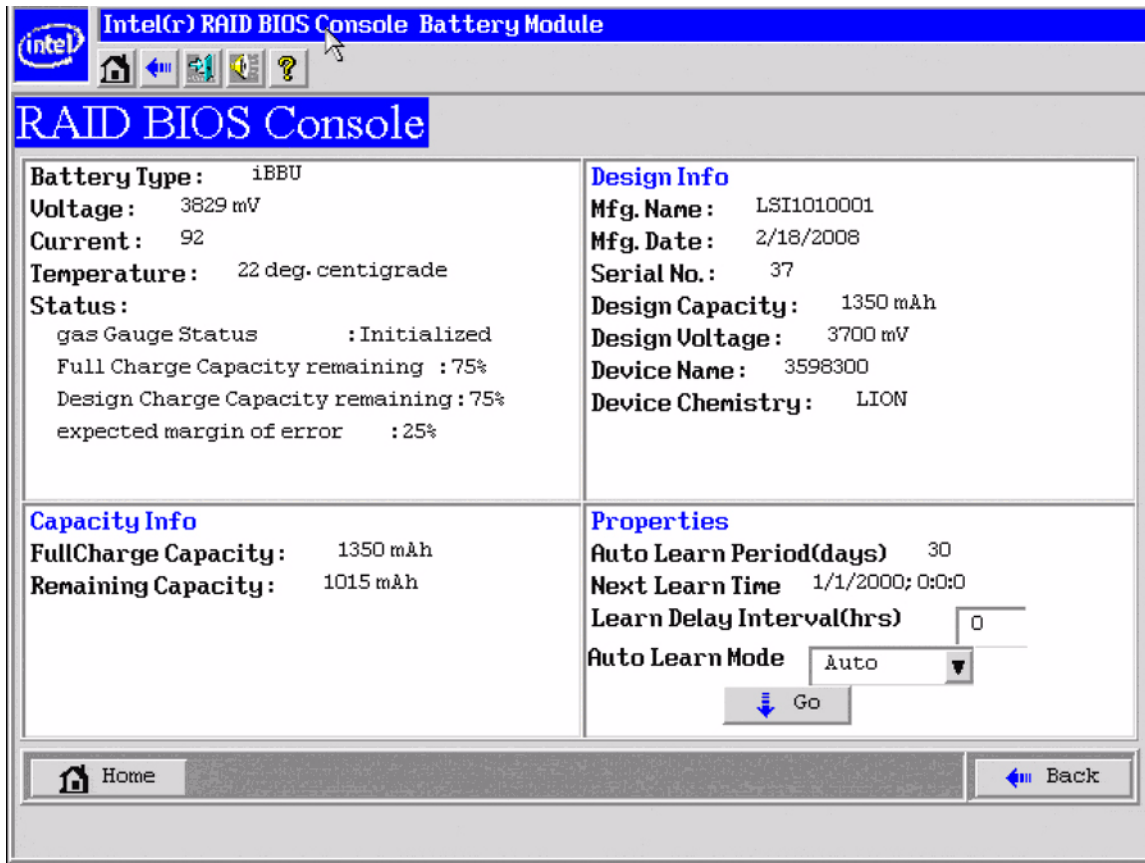

Figure 9. Monitoring the Battery with Intel® RAID BIOS Console

Most of the battery module properties are view-only. In the lower right panel of the Intel® RAID BIOS Console screen, there are two properties that can be changed. Although Intel recommends that you use the default settings for these options. The default settings for the two properties are:

- Learn Delay Interval (hrs) - The default is 0 hour.
- Auto Learn Mode - The default is Auto.

Note: *The learning cycle is a battery calibration operation performed periodically by the controller to determine the condition of the battery.*

Using Intel® RAID Web Console 2

To view the status of all BBUs connected to controllers in the server, select the Physical tab in the left panel of the Intel® RAID Web Console 2. To see the battery, select the controller. The Battery Backup Unit appears as the last item on the list under that

controller (see Figure 10). An icon (small rectangle or red dot) appears in the left pane to indicate the BBU status. The rectangle indicates normal operation; a red dot indicates the BBU has failed.

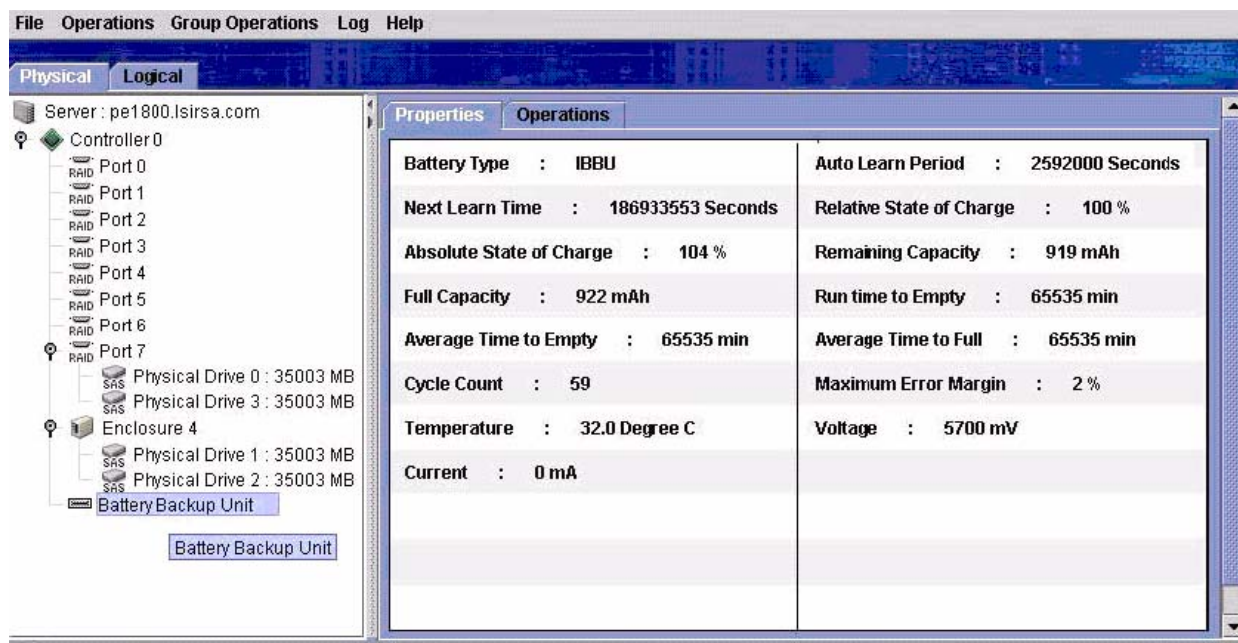

Figure 10. BBU information in Intel® RAID Web Console 2

The Battery Backup Unit properties include:

- The number of times the BBU has been recharged (Cycle Count).
- The full capacity of the BBU, percentage of the current charge, and the estimated time until the charge will be depleted.
- The BBU temperature, voltage, current, and remaining capacity.
- The estimated time until the battery is fully charged if the battery is currently charging.

Learn cycle is a battery calibration operation performed by the controller periodically to determine the condition of the battery. You can start battery learn cycles manually or automatically. To choose automatic battery learn cycles, enable automatic learn cycles. To choose manual battery learn cycles, disable automatic learn cycles.

If you enable automatic learn cycles, you can delay the start of the learn cycles for up to 168 hours (7 days). If you disable automatic learn cycles, you can start the learn cycles manually, and you can choose to receive a reminder to start a manual learn cycle.

4 Replacing Battery Backup Units

Intel recommends that you replace each BBU once a year or after 500 recharging cycles, whichever comes first. The battery pack has a one year warranty. After you install a new BBU, use one of the Intel configuration utilities to reset the battery recharge cycle counter to zero. For instructions, see [“Monitoring the BBU with the Intel® RAID BIOS Configuration Utility”](#) on page 13.

Disposing of Battery Backup Units

Warning: *Do not damage the battery pack in any way. Toxic chemicals can be released if it is damaged.*

The material in the battery pack contains heavy metals that can contaminate the environment. Federal, state, and local regulations prohibit the disposal of rechargeable batteries in public landfills. Be sure to recycle old battery packs properly. Intel would like to remind you that you must comply with all applicable battery disposal and hazardous material handling laws and regulations in the country or other jurisdiction where you are using the BBU.

5 Battery Backup Unit Specifications

Table 2. BBU Specifications

Battery Technology	Lithium-Ion (Li-Ion)
Battery Operating Environment	10-40°C dry bulb temperature The maximum dry bulb temperature shall be derated by 3.3° C per 1000 m above 500 m)
	20% to 80% relative humidity non-condensing
Battery Storage Temperature	Depends on storage time: <ul style="list-style-type: none">• < 30 days: 0-50°C• 30-90 days: 0-40°C• > 90 days: 0-30°C
Fast Charge Rate	500 mAH
Battery Voltage	Nominal Battery Voltage: 3.7 V
Mechanical	3.160 inches x 2.122 inches (battery extends over PCB)
Battery Capacity	1350 mAH
Battery Charge Time	Typical: Approximate 4 hours
Battery Shelf Life	1 year
Battery Operational Life	Intel provides a one year warranty on the Intel® RAID Smart Battery AXXRSBBU7
Memory	DDR2 SDRAM 800MHz (1.8 V), maximum 72-bit bus width
Smart Battery Monitoring	Temperature is monitored using the I ² C interface; Supports v1.1 “Smart Battery System Manager”
Auxiliary Power	Ability to detect the presence of an external auxiliary power source. Circuitry automatically chooses auxillary power and defers discharge until auxillary power is removed or exhausted. Auxillary power increases the DRT ratings.

Battery Life and Data Retention Time

The Intel utilities display a counter showing the number of times a BBU has been recharged. When you replace a BBU, you should run the utility program and reset this counter to zero for the new BBU. Intel recommends that you replace the battery pack on the BBU once a year or after 500 recharging cycles, whichever comes first. The battery pack has a one year warranty.

The data retention time is 72 hours (low power) if using the RAM listed below. This rating is approximate and can vary based on battery load, ambient temperature, and number of discharge cycles associated with the battery.

- 72 hours for 512 MB, using five 64 M x 16 parts DDR2 (low power)
- 72 hours for 256 MB, using five 32 M x 16 parts DDR2 (low power)
- 72 hours for 128 MB, using five 16 M x 16 parts DDR2 (low power)

X-ON Electronics

Largest Supplier of Electrical and Electronic Components

Click to view similar products for [Battery Packs](#) category:

Click to view products by [Intel](#) manufacturer:

Other Similar products are found below :

[R101-B](#) [31000-000067-RS](#) [4600 726 406](#) [4610 726 406](#) [312G-U1](#) [55615703012](#) [4606 726 406](#) [4607 726 406](#) [ZA13](#)
[LR03/AAA/MN2400\(K4\)](#) [LR03 MAXELL S4](#) [LR1130 MAXELL B10](#) [LR14-MN1400-C K2](#) [LR1/910A](#) [LR41 MAXELL B10](#) [LR43](#) [LR43](#)
[MAXELL B10](#) [LR6 MAXELL S4](#) [E23A](#) [E90](#) [625302](#) [625304](#) [637871](#) [638006](#) [6LF22/9V/MN1604\(K1\)C&B](#) [6LF22/9V/MN1604 PLUS](#)
[6LR61](#) [SR626SW MAXELL](#) [SR920SW MAXELL](#) [7K67 J](#) [55615303059](#) [220AAH-B AA](#) [GP14A S2](#) [GP 15AU ULTRA PLUS B4](#) [GP15E](#)
[GP1604GLF-2UE1](#) [GP 1604 ULTRA PLUS](#) [GP 24AU ULTRA PLUS B4](#) [10 ET](#) [675 ET](#) [11A B5](#) [A544](#) [A76-U10](#) [13G U2](#) [4112101411](#) [4](#)
[022 211 111](#) [GP24A/FO2 SUPER](#) [GP15A/F02 SUPER](#) [4 106 101 436](#) [4 014 211 111](#)