

Intel® NUC 8 Compute Element Product Specification

Revision 1.2

Regulatory Model: CM8CB

March 2021

Intel® NUC 8 CM8CCB4R, CM8PCB4R, CM8I3CB4N, CM8I5CB8N, CM8V5CB8N, CM8I7CB8N or CM8V7CB8N may contain design defects or errors known as errata that may cause the product to deviate from published specifications. Current characterized errata, if any, are documented in this product specification

Revision History

Revision	Revision History	Date
1.0	First release	October 2019
1.1	BIOS version number updated, processor stepping/spec updated, connector pin out changed.	July 2020
1.2	Product name changed. Added note that SATA is not supported on CM8CCB4R and CM8PCB4R	March 2021

Disclaimer

This product specification applies only to the standard Intel® NUC 8 Element with BIOS identifier CBWHL357.86A or CBWHLMIV.86A.

INFORMATION IN THIS DOCUMENT IS PROVIDED IN CONNECTION WITH INTEL® PRODUCTS. NO LICENSE, EXPRESS OR IMPLIED, BY ESTOPPEL OR OTHERWISE, TO ANY INTELLECTUAL PROPERTY RIGHTS IS GRANTED BY THIS DOCUMENT. EXCEPT AS PROVIDED IN INTEL'S TERMS AND CONDITIONS OF SALE FOR SUCH PRODUCTS, INTEL ASSUMES NO LIABILITY WHATSOEVER, AND INTEL DISCLAIMS ANY EXPRESS OR IMPLIED WARRANTY, RELATING TO SALE AND/OR USE OF INTEL PRODUCTS INCLUDING LIABILITY OR WARRANTIES RELATING TO FITNESS FOR A PARTICULAR PURPOSE, MERCHANTABILITY, OR INFRINGEMENT OF ANY PATENT, COPYRIGHT OR OTHER INTELLECTUAL PROPERTY RIGHT. UNLESS OTHERWISE AGREED IN WRITING BY INTEL, THE INTEL PRODUCTS ARE NOT DESIGNED NOR INTENDED FOR ANY APPLICATION IN WHICH THE FAILURE OF THE INTEL PRODUCT COULD CREATE A SITUATION WHERE PERSONAL INJURY OR DEATH MAY OCCUR.

All Intel® NUC 8 Compute Elements are evaluated as Information Technology Equipment (I.T.E.) for use in personal computers (PC) for installation in homes, offices, schools, computer rooms, and similar locations. The suitability of this product for other PC or embedded non-PC applications or other environments, such as medical, industrial, alarm systems, test equipment, etc. may not be supported without further evaluation by Intel.

Intel Corporation may have patents or pending patent applications, trademarks, copyrights, or other intellectual property rights that relate to the presented subject matter. The furnishing of documents and other materials and information does not provide any license, express or implied, by estoppel or otherwise, to any such patents, trademarks, copyrights, or other intellectual property rights.

Intel may make changes to specifications and product descriptions at any time, without notice.

Designers must not rely on the absence or characteristics of any features or instructions marked "reserved" or "undefined." Intel reserves these for future definition and shall have no responsibility whatsoever for conflicts or incompatibilities arising from future changes to them.

Intel processor numbers are not a measure of performance. Processor numbers differentiate features within each processor family, not across different processor families: Go to:

[Learn About Intel® Processor Numbers](#)

Intel® NUC 8 Compute Elements may contain design defects or errors known as errata, which may cause the product to deviate from published specifications. Current characterized errata are available on request.

Contact your local Intel sales office or your distributor to obtain the latest specifications before placing your product order.

Intel, the Intel logo and Intel Core are trademarks of Intel Corporation in the U.S. and/or other countries.

* Other names and brands may be claimed as the property of others.

Copyright © 2019 Intel Corporation. All rights reserved.

Preface

This Product Specification specifies the layout, components, connectors, power, and environmental features for the Intel® NUC 8 CM8CCB4R, CM8PCB4R, CM8I3CB4N, CM8I5CB8N, CM8V5CB8N, CM8I7CB8N or CM8V7CB8N.



NOTE

In this document, the use of “Intel® NUC 8 Compute Element” will refer to the CM8CCB4R, CM8PCB4R, CM8I3CB4N, CM8I5CB8N, CM8V5CB8N, CM8I7CB8N and CM8V7CB8N versions.

Intended Audience

This document is intended to provide technical information about Intel® NUC 8 CM8CCB4R, CM8PCB4R, CM8I3CB4N, CM8I5CB8N, CM8V5CB8N, CM8I7CB8N or CM8V7CB8N and its components to the vendors, system integrators, and other engineers and technicians who need this level of information. It is specifically *not* intended for general audiences.

What This Document Contains

Chapter	Description
1	A description of the CM8CCB4R, CM8PCB4R, CM8I3CB4N, CM8I5CB8N, CM8V5CB8N, CM8I7CB8N or CM8V7CB8N features
2	A technical description of the CM8CCB4R, CM8PCB4R, CM8I3CB4N, CM8I5CB8N, CM8V5CB8N, CM8I7CB8N or CM8V7CB8N

Typographical Conventions

This section contains information about the conventions used in this specification. Not all of these symbols and abbreviations appear in all specifications of this type.

Notes, Cautions, and Warnings



NOTE

Notes call attention to important information.



CAUTION

Cautions are included to help you avoid damaging hardware or losing data.

Other Common Notation

#	Used after a signal name to identify an active-low signal (such as USBP0#)
GB	Gigabyte (1,073,741,824 bytes)
GB/s	Gigabytes per second
Gb/s	Gigabits per second
KB	Kilobyte (1024 bytes)
Kb	Kilobit (1024 bits)
kb/s	1000 bits per second
MB	Megabyte (1,048,576 bytes)
MB/s	Megabytes per second
Mb	Megabit (1,048,576 bits)
Mb/s	Megabits per second
TDP	Thermal Design Power
Xxh	An address or data value ending with a lowercase h indicates a hexadecimal value.
x.x V	Volts. Voltages are DC unless otherwise specified.
*	This symbol is used to indicate third-party brands and names that are the property of their respective owners.

Intel® NUC 8 Compute Element Identification Information

Intel® NUC 8 Compute Element Identification Information

AA Revision	Product Code	Original BIOS Revision	Notes
K53739-203	BKCM8CCB4R	CBWHL357.0058	1,2
K53742-203	BKCM8PCB4R	CBWHL357.0058	1,3
K53744-203	BKCM8I3CB4N	CBWHL357.0058	1,4
K53746-203	BKCM8I5CB8N	CBWHL357.0058	1,5
K53774-203	BKCM8V5CB8N	CBWHLMIV.0058	1,6
K53740-203	BKCM8I7CB8N	CBWHL357.0058	1,7
K53738-203	BKCM8V7CB8N	CBWHLMIV.0058	1,8

Notes:

- The AA number is found on the Mylar cover.
- The Intel® Celeron® 4305U processor is used on this AA revision consisting of the following component:

Device	Stepping	Spec Code
Intel® Celeron® 4305U	V0	SRFA5

- The Intel® Pentium® Gold 5405U processor is used on this AA revision consisting of the following component:

Device	Stepping	Spec Code
Intel® Pentium® Gold 5405U	V0	SRFG1

- The Intel® Core™ i3-8145U processor is used on this AA revision consisting of the following component:

Device	Stepping	Spec Code
Intel® Core™ i3-8145U	V0	SRFFZ

- The Intel® Core™ i5-8265U processor is used on this AA revision consisting of the following component:

Device	Stepping	Spec Code
Intel Core™ i5-8265U	V0	SRFFX

- The Intel® Core™ i5-8365U processor is used on this AA revision consisting of the following component:

Device	Stepping	Spec Code
Intel® Core™ i5-8365U	V0	SRF9Z

- The Intel® Core™ i5-8365U processor is used on this AA revision consisting of the following component:

Device	Stepping	Spec Code
Intel® Core™ i7-8565U	V0	SRFFW

- The Intel® Core™ i5-8365U processor is used on this AA revision consisting of the following component:

Device	Stepping	Spec Code
Intel® Core™ i7-8665U	V0	SRF9W

Specification Changes or Clarifications

The table below indicates the Specification Changes or Specification Clarifications that apply to the Intel® NUC 8 CM8CCB4R, CM8PCB4R, CM8I3CB4N, CM8I5CB8N, CM8V5CB8N, CM8I7CB8N or CM8V7CB8N.

Specification Changes or Clarifications

Date	Type of Change	Description of Changes or Clarifications
July 2020	BIOS Version, connector	Clarified actual BIOS versions for current shipping products, changed pin numbers 214, 216, 220 and 222 to reserved
March 2021	Feature Support	SATA is not supported on CM8CCB4R and CM8PCB4R

Errata

Current characterized errata, if any, will be documented in Section 4 of this Product Specification.

Contents

Revision History	ii
Disclaimer	ii
Preface	iii
Intended Audience.....	iii
What This Document Contains	iii
Typographical Conventions	iii
Intel® NUC 8 Compute Element Identification Information	v
Specification Changes or Clarifications.....	vi
Errata.....	vi
Contents	vii
2 Product Description	9
2.1 Overview	9
2.2 Version Summary.....	9
2.3 Feature Summary.....	10
3 Technical Reference	12
3.1 Block Diagram.....	12
3.2 Compute Element Exterior	13
3.3 Connector	14
3.3.1 Connector Pin-Out.....	15
3.4 Antenna Connection	19
3.5 BIOS Security Switch.....	19
3.6 Power.....	21
3.7 Mechanical	21
3.8 Thermal	23
3.9 Environmental	24
4 Characterized Errata	25
Figures	
Figure 1. Block Diagram.....	12
Figure 2. Integrated Heat Shield Side.....	13
Figure 3. Mylar Side.....	13
Figure 4. Connector with Pinout – Mylar Side.....	14
Figure 5. Connector with Pinout – IHS Side	14
Figure 6. Location of the Antenna Connectors.....	19
Figure 7. Location of the BIOS Security Switch	20
Figure 8. Mylar Side.....	21

Figure 9. Integrated Heat Shield Side.....	22
Figure 10. Front (Showing Connector).....	22
Figure 11. Back.....	22
Figure 12. Left.....	22
Figure 13. Right.....	23

Tables

Table 1. Version Summary.....	9
Table 2. Feature Summary.....	10
Table 3. LOTES Connector Options.....	14
Table 4. Connector Segment One with Pin Numbers and Signals.....	15
Table 5. Connector Segment Two with Pin Numbers and Signals.....	16
Table 6. Connector Segment Three with Pin Numbers and Signals.....	17
Table 7. Connector Segment Four with Pin Numbers and Signal.....	18
Table 8. BIOS Security Switch Settings.....	20
Table 9. Environmental Specifications.....	24

2 Product Description

2.1 Overview

The Intel® NUC 8 Compute Element are System-on-Module architecture optimized for integrated designs. The NUC 8 Compute Element consists of the processor, memory, wireless, Bluetooth*, integrated heat shield and depending on the model may include storage and discrete TPM. See Table 1 for a summary.

The Intel® NUC 8 Compute Element requires a compatible carrier board in order to operate.

For information on compatible devices for use with the Intel® NUC 8 Compute Element see <http://www.intel.com/NUCElements>.

2.2 Version Summary

There are eight different versions of this model of Intel® NUC 8 Compute Element available which are summarized in Table 1. Unless otherwise noted in this document, not all features are available on all versions.

Table 1. Version Summary

Version	Intel® vPro™	Discrete TPM	Memory	Storage	Processor
CM8CCB4R	No	No	4 GB	64 GB	Intel® Celeron® 4305U
CM8PCB4R	No	No	4 GB	64 GB	Intel® Pentium® Gold 5405U
CM8I3CB4N	No	No	4 GB	None	Intel® Core™ i3-8145U
CM8I5CB8N	No	No	8 GB	None	Intel® Core™ i5-8265U
CM8V5CB8N	Yes	Yes	8 GB	None	Intel® Core™ i5-8365U
CM8I7CB8N	No	No	8 GB	None	Intel® Core™ i7-8565U
CM8V7CB8N	Yes	Yes	8 GB	None	Intel® Core™ i7-8665U



NOTE

Intel® NUC 8 Compute Elements listed in Table 1 have been certified for use as a component in Information Technology Equipment in certain countries. The system integrator is responsible for testing and acquiring any additional country-specific regulatory approvals, including all system-wide certifications.



NOTE

For information on how to design a carrier board and/or an enclosure for the Intel® NUC 8 Compute Element a design guide is available on [MyIntel](#).

2.3 Feature Summary

Table 2 summarizes the major features of the Intel® NUC 8 Compute Elements.

Table 2. Feature Summary

Size	95 millimeters by 65 millimeters by 6 millimeters
Processor	<ul style="list-style-type: none"> • Soldered-down Intel® processor <ul style="list-style-type: none"> ○ Integrated graphics ○ Integrated memory controller ○ Integrated PCH • The following processors are supported <ul style="list-style-type: none"> ○ Intel® Celeron® 4305U ○ Intel® Pentium® Gold 5405U ○ Intel® Core™ i3-8145U ○ Intel® Core™ i5-8265U ○ Intel® Core™ i5-8365U ○ Intel® Core™ i7-8565U ○ Intel® Core™ i7-8665U
Memory	<ul style="list-style-type: none"> • Soldered-down dual-channel LPDDR3 memory • 4 GB total memory for CM8CCB4R, CM8PCB4R at 1866 MHz • 4GB total memory for CM8I3CB4N at 2133 MHz • 8 GB total memory for CM8I5CB8N, CM8V5CB8N, CM8I7CB8N and CM8V7CB8N at 2133 MHz
Graphics	<p>Integrated graphics support with Intel® HD Graphics Technology</p> <ul style="list-style-type: none"> • Two Digital Display Interface (DDI) lanes are available from the Compute Element connector that are configured as DisplayPort++ (HDMI can be supported on the carrier board) • High-Bandwidth Digital Content Protection support for content protection <ul style="list-style-type: none"> ○ HDCP 2.2 supported via DisplayPort* ○ HDCP 1.4 supported via HDMI* • Resolutions and refresh rates supported <ul style="list-style-type: none"> ○ Up to 4K @ 60Hz via DisplayPort ○ Up to 4K @ 30Hz via HDMI
Audio	Intel® High Definition (Intel® HD) Audio via the Digital Display Lanes using either DisplayPort or HDMI
Storage	64GB soldered down eMMC 5.1 HS400 for CM8PCB4R and CM8CCB4R There is no onboard storage for CM8I3CB4N, CM8I5CB8N, CM8V5CB8N, CM8I7CB8N and CM8V7CB8N
BIOS	<ul style="list-style-type: none"> • Intel® BIOS resident in the Serial Peripheral Interface (SPI) Flash device • Support for Advanced Configuration and Power Interface (ACPI), Plug and Play, and System Management BIOS (SMBIOS)
Wireless LAN	<p>Soldered-down Intel® Dual Band Wireless-AC 9560</p> <ul style="list-style-type: none"> • 802.11a/b/g/n, 802.11ac, Bluetooth* 5.0 • Antennas are not included
Interfaces Supported via the Edge Connector	<ul style="list-style-type: none"> • 4 USB 3.1 (Gen 2¹) • 3 USB 2.0 • 1 PCIe x1 (Gen 3) • 1 PCIe x4 (Gen 3) • 1 PCIe x4 (Gen 3) or SATA III² (configurable) • 1 GbE PHY

¹ USB 3.1 (Gen 1) is supported on the CM8PCB4R

² SATA III is not supported on CM8PCB4R and CM8CCB4R

Advanced Technologies	<ul style="list-style-type: none"> • Intel® vPro™ Technology (CM8V5CB8N and CM8V7CB8N only) • Intel® Virtualization Technology (VT-x) • Intel® Virtualization for Directed I/O (VT-d) • Intel® VT-x with Extended Page Tables (EPT) • Intel® Speed Shift Technology • Intel® Turbo Boost Technology • Intel® Hyper-Threading Technology • Enhanced Intel® SpeedStep® Technology • Intel® Identity Protection Technology (Intel® IPT) • Intel® Platform Trust Technology (Intel® PTT) – (CM8CCB4R, CM8PCB4R, CM8I3CB4N, CM8I5CB8N and CM8I7CB8N only)
Security and Reliability	<ul style="list-style-type: none"> • Intel® Active Management Technology 11.0 (Intel® AMT) – (CM8V5CB8N and CM8V7CB8N only) • Intel® Trusted Execution Technology (Intel® TXT) – (CM8V5CB8N and CM8V7CB8N only) • Intel® Memory Protection Extensions (Intel® MPX) • Intel® Software Guard Extensions (Intel® SGX) • Intel® AES New Instructions • Execute Disable Bit • Nuvoton NPCT650AAAYx Discreet Trusted Platform Module 2.0 (TPM) – (CM8V5CB8N and CM8V7CB8N only)
Operating Systems Support (64-bit only)	<ul style="list-style-type: none"> • Windows* 10 Home • Windows 10 Pro • Windows 10 Enterprise • Windows 10 Education • Windows 10 IoT Enterprise • Some Linux* operating systems may be supported. Check with the specific Linux distribution to make sure that support is available for this platform.
Supported Connectors	<ul style="list-style-type: none"> • Lotes APCI0468-P001A01 Edge Mount Connector • Lotes APCI0468-P002A01 Edge Mount Connector • Lotes APCI0480-P001A01 Surface Mount Connector • Lotes APCI0480-P002A01 Surface Mount Connector

To find information about...

- Intel® NUC Elements
- Intel® NUC Element Support
- Intel® NUC Element Warranty Information
- Available configurations for Intel® NUC Compute Element
- Intel Processors
- Intel Graphics
- Intel Wireless
- Intel Technologies

Visit this World Wide Web site:

- <http://www.intel.com/ComputeElements>
- <http://www.intel.com/ComputeElementsSupport>
- <http://www.intel.com/NUCWarranty>
- <http://ark.intel.com>
- <http://www.intel.com/processors>
- <http://www.intel.com/graphics>
- <http://www.intel.com/wireless>
- <http://www.intel.com/technology>

3 Technical Reference

3.1 Block Diagram

Figure 1 is a block diagram of the major functional areas of Intel® NUC 8 Compute Element.

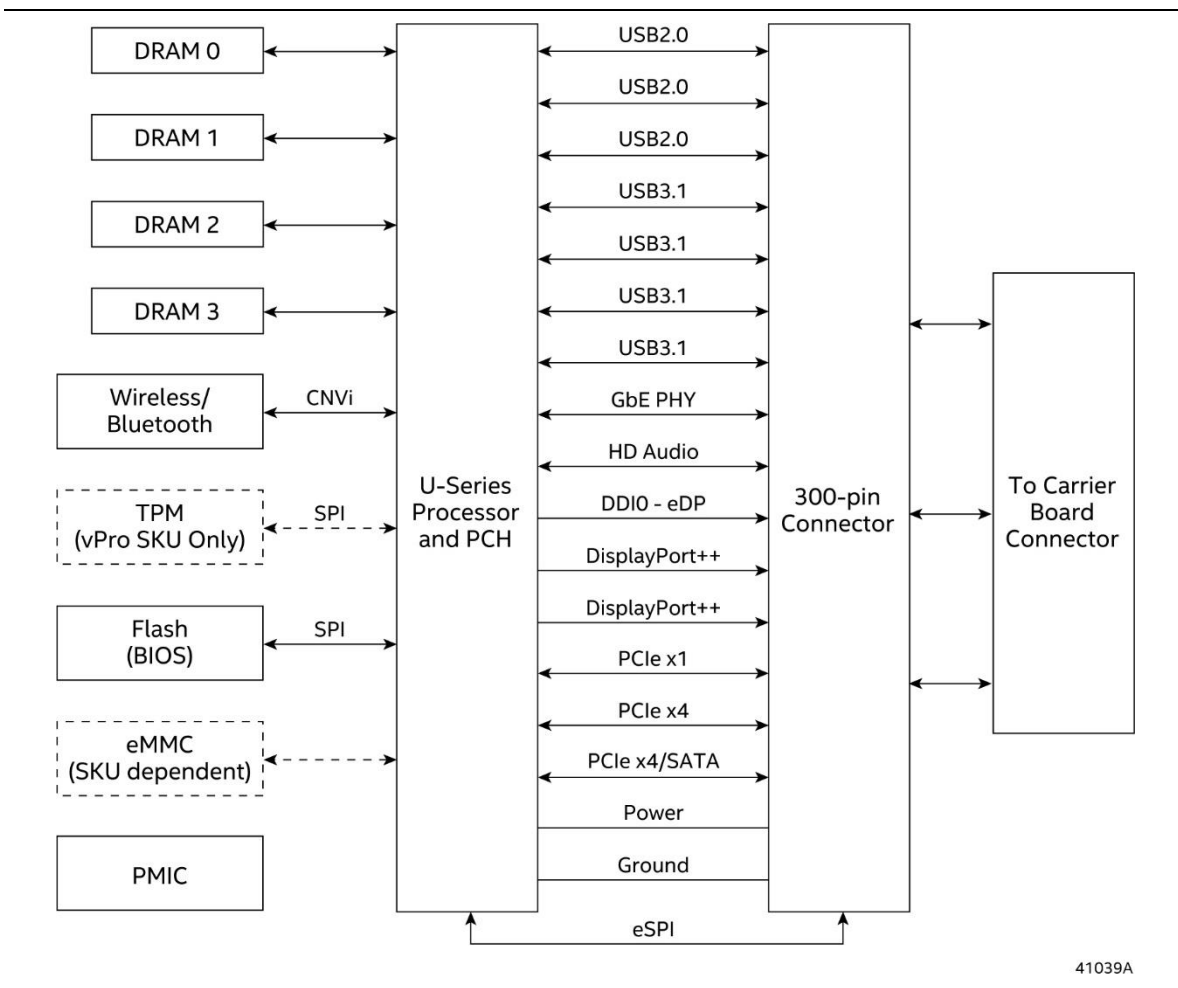
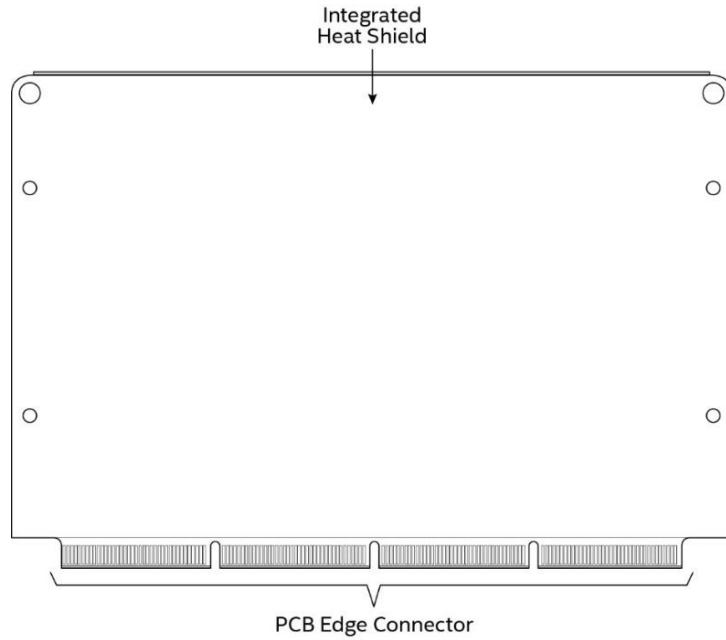

Figure 1. Block Diagram

3.2 Compute Element Exterior

The NUC 8 Compute Element has a set of gold fingered connections along one edge. On one side is the Integrated Heat Shield (IHS). On the other side is a Mylar cover for the PCB. See Figure 2 and Figure 3.



41017

Figure 2. Integrated Heat Shield Side

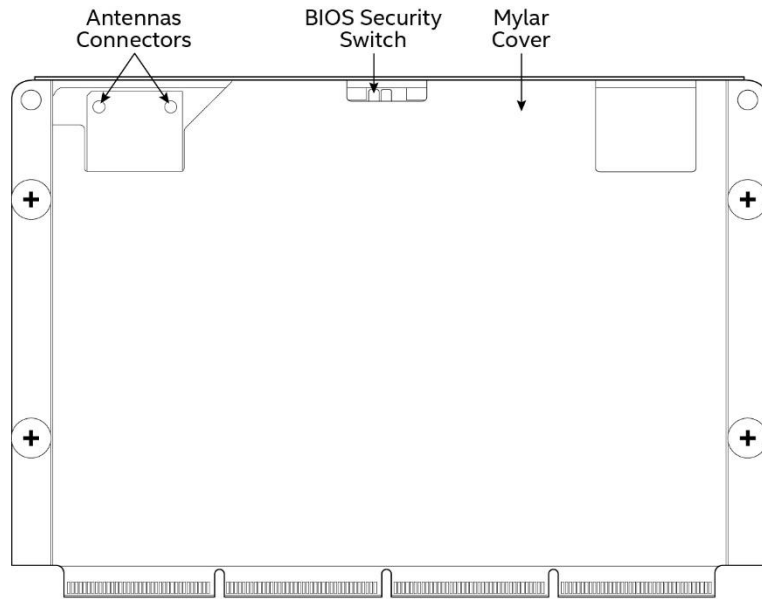

41016

Figure 3. Mylar Side

3.3 Connector

The NUC 8 Compute Element gold finger edge connector mates with the following LOTES* connectors shown in Table 3.

Table 3. LOTES Connector Options

Part Number	Description
APCI0468-P001A01	Edge Mount, LCP_Black, Copper Alloy, Au_15u"
APCI0468-P002A01	Edge Mount, LCP_Black, Copper Alloy, Au_30u"
APCI0480-P001A01	Surface Mount, LCP_Black, Copper Alloy, Au_15u"
APCI0480-P002A01	Surface Mount, LCP_Black, Copper Alloy, Au_30u"

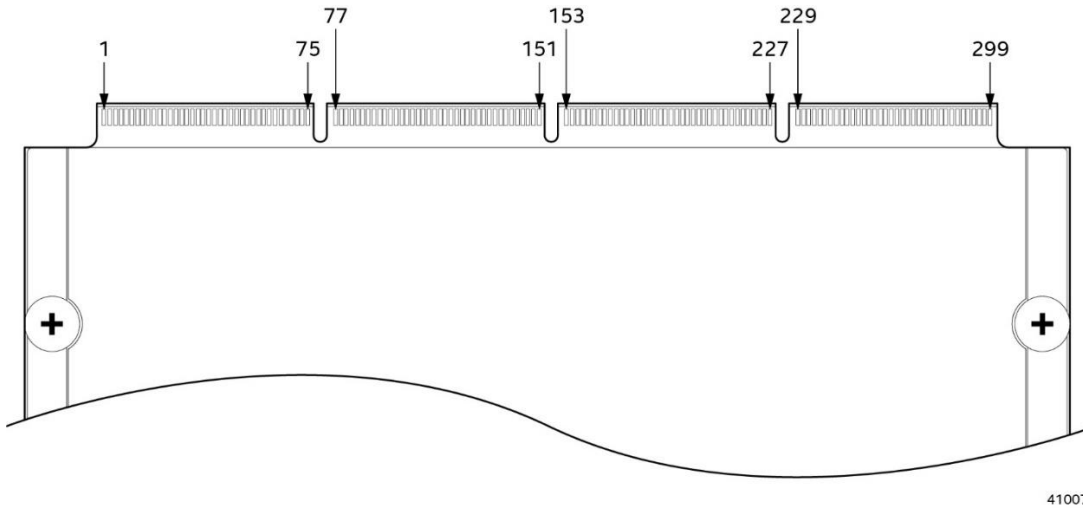

Figure 4. Connector with Pinout – Mylar Side

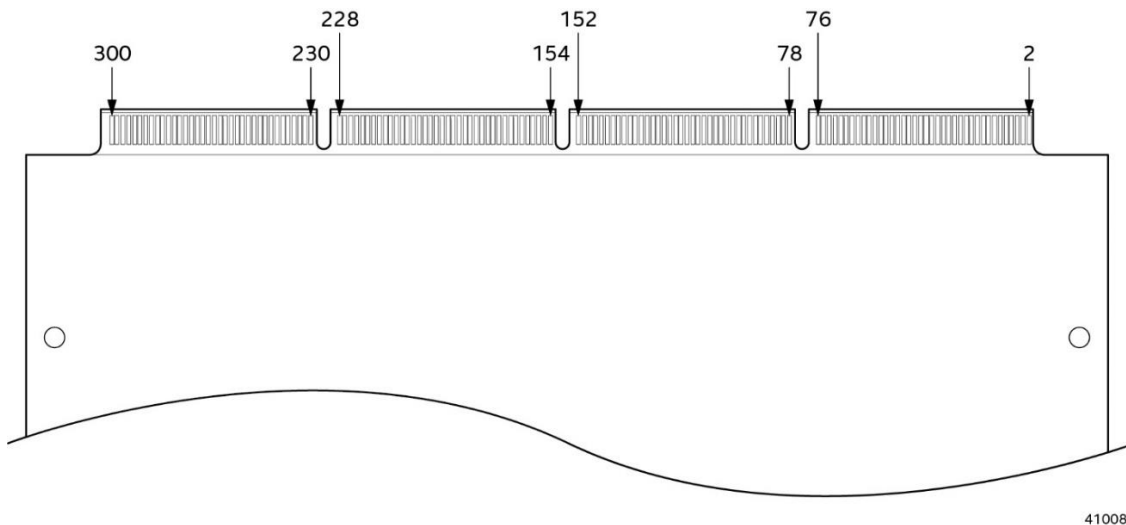

Figure 5. Connector with Pinout – IHS Side

3.3.1 Connector Pin-Out

The below tables list the pin numbers and their signals:

Table 4. Connector Segment One with Pin Numbers and Signals

Pin	Signal	Pin	Signal
1	VBAT_PWR	2	GND
3	VBAT_PWR	4	DDI2_Lane0_Dn
5	VBAT_PWR	6	DDI2_Lane0_Dp
7	VBAT_PWR	8	GND
9	VBAT_PWR	10	DDI2_Lane1_Dn
11	VBAT_PWR	12	DDI2_Lane1_Dp
13	VBAT_PWR	14	GND
15	VBAT_PWR	16	DDI2_Lane2_Dn
17	VBAT_PWR	18	DDI2_Lane2_Dp
19	VBAT_PWR	20	GND
21	No Connect	22	DDI2_Lane3_Dn
23	COIN_RTC_3p3V_IN	24	DDI2_Lane3_Dp
25	RSVD	26	GND
27	PCIe_SRC0_CLK_Dn	28	DDI1_Lane0_Dn
29	PCIe_SRC0_CLK_Dp	30	DDI1_Lane0_Dp
31	GND	32	GND
33	PCIe_SRC1_CLK_Dn	34	DDI1_Lane1_Dn
35	PCIe_SRC1_CLK_Dp	36	DDI1_Lane1_Dp
37	GND	38	GND
39	PCIe_SRC2_CLK_Dn	40	DDI1_Lane2_Dn
41	PCIe_SRC2_CLK_Dp	42	DDI1_Lane2_Dp
43	GND	44	GND
45	PCIe_SRC3_CLK_Dn	46	DDI1_Lane3_Dn
47	PCIe_SRC3_CLK_Dp	48	DDI1_Lane3_Dp
49	GND	50	GND
51	RSVD	52	DDI1_AUX_Dn
53	RSVD	54	DDI1_AUX_Dp
55	GND	56	DDI1_HPD_Q
57	CLKREQ_SRC0_N	58	DG_CIO_PLUG_EVENT_N
59	CLKREQ_SRC1_N	60	RSVD
61	CLKREQ_SRC2_N	62	GND
63	CLKREQ_SRC3_N	64	SUSCLK
65	RSVD	66	GND
67	GND	68	ACPRESENT
69	DDI2_AUX_Dp	70	BATLOW#
71	DDI2_AUX_Dn	72	INTRUDER
73	DDI2_HPD_Q	74	THRMTRIP#
75	GND	76	Psys_Input

Table 5. Connector Segment Two with Pin Numbers and Signals

Pin	Signal	Pin	Signal
77	GND	78	GND
79	PCIE13_M2_SSD_RX_Dn	80	eDP_Tx0_Dn
81	PCIE13_M2_SSD_RX_Dp	82	eDP_Tx0_Dp
83	GND	84	GND
85	PCIE13_M2_SSD_R_TX_Dn	86	eDP_Tx1_Dn
87	PCIE13_M2_SSD_R_TX_Dp	88	eDP_Tx1_Dp
89	GND	90	GND
91	PCIE14_M2_SSD_RX_Dn	92	eDP_Tx2_Dn
93	PCIE14_M2_SSD_RX_Dp	94	eDP_Tx2_Dp
95	GND	96	GND
97	PCIE14_M2_SSD_TX_Dn	98	eDP_Tx3_Dn
99	PCIE14_M2_SSD_TX_Dp	100	eDP_Tx3_Dp
101	GND	102	GND
103	PCIE15_M2_SSD_RX_Dn	104	eDP_AUX_Dn
105	PCIE15_M2_SSD_RX_Dp	106	eDP_AUX_Dp
107	GND	108	eDP_HPD_Q
109	PCIE15_M2_SSD_TX_Dn	110	GND
111	PCIE15_M2_SSD_TX_Dp	112	eDP_VDD_En
113	GND	114	eDP_BKLT_Ctrl
115	PCIE16_SATA2_M2_SSD_RX_Dn	116	eDP_BKLT_En
117	PCIE16_SATA2_M2_SSD_RX_Dp	118	GND
119	GND	120	DDC1_CTRL_CK
121	PCIE16_SATA2_M2_SSD_RX_Dn	122	DDC1_CTRL_DATA
123	PCIE16_SATA2_M2_SSD_TX_Dp	124	DDC2_CTRL_CK
125	GND	126	DDC2_CTRL_DATA
127	RSVD	128	RSVD
129	RSVD	130	GND
131	GND	132	HDA_SYNC
133	RSVD	134	HDA_BCLK
135	RSVD	136	HDA_SDO
137	GND	138	HDA_SDIO
139	PCIE10_P1_RX_Dn	140	HDA_SDI1/SNDW1_DATA
141	PCIE10_P1_RX_Dp	142	HDA_RSTB/SNDW1_CLK
143	GND	144	PCH_SPKR
145	PCIE10_P1_TX_Dn	146	GND/DETECT
147	PCIE10_P1_TX_Dp	148	RSVD
149	GND	150	RSVD
151	DG_PERST_N	152	RSVD

Table 6. Connector Segment Three with Pin Numbers and Signals

Pin	Signal	Pin	Signal
153	SML0_CLK	154	SML0_DATA
155	GND	156	GND
157	RSVD	158	USB2_P1_Dn
159	RSVD	160	USB2_P1_Dp
161	GND	162	GND
163	RSVD	164	USB2_P2_Dn
165	RSVD	166	USB2_P2_Dp
167	GND	168	GND
169	PCIE9_LAN_RX_Dn	170	USB2_P3_Dn
171	PCIE9_LAN_RX_Dp	172	USB2_P3_Dp
173	GND	174	GND
175	PCIE9_LAN_TX_Dn	176	USB2_P4_Dn
177	PCIE9_LAN_TX_Dp	178	USB2_P4_Dp
179	GND	180	GND
181	PCIE5_X4_RX_Dn	182	USB_OC_0_N
183	PCIE5_X4_RX_Dp	184	LAN_WAKE_N
185	GND	186	PCH_EC_SLPSUS_L
187	PCIE5_X4_TX_Dn	188	PCH_EC_SLP_S0
189	PCIE5_X4_TX_Dp	190	WIFI_DISABLE_N
191	GND	192	LAN_DISABLE_N
193	PCIE6_X4_RX_Dn	194	GND
195	PCIE6_X4_RX_Dp	196	ESPI_IO_0
197	GND	198	ESPI_IO_1
199	PCIE6_X4_TX_Dn	200	ESPI_IO_2
201	PCIE6_X4_TX_Dp	202	ESPI_IO_3
203	GND	204	ESPI_CS_N
205	PCIE7_X4_RX_Dn	206	ESPI_RESET_N
207	PCIE7_X4_RX_Dp	208	GND
209	GND	210	ESPI_CLK
211	PCIE7_X4_TX_Dn	212	GND
213	PCIE7_X4_TX_Dp	214	RSVD
215	GND	216	RSVD
217	PCIE8_X4_RX_Dn	218	GND
219	PCIE8_X4_RX_Dp	220	RSVD
221	GND	222	RSVD
223	PCIE8_X4_TX_Dn	224	GND
225	PCIE8_X4_TX_Dp	226	PECI
227	GND	228	GND

Table 7. Connector Segment Four with Pin Numbers and Signal

Pin	Signal	Pin	Signal
229	SML1_CLK	230	SMB_CLK
231	SML1_DATA	232	SMB_DATA
233	GND	234	SMB_ALERT_N
235	USB3_P1_TX_Dp	236	GND
237	USB3_P1_TX_Dn	238	SML0_ALERT_N
239	GND	240	SML1_ALERT_N
241	USB3_P1_RX_Dp	242	GND
243	USB3_P1_RX_Dn	244	DG_PCIE_WAKE_N
245	GND	246	PCH_SATA2_PEDET
247	USB3_P2_TX_Dp	248	DG_RTD3_PWR_EN
249	USB3_P2_TX_Dn	250	PCH_M2_DEVSLEP
251	GND	252	PCH_PCIE_WAKE_N
253	USB3_P2_RX_Dp	254	PCH_SATA_LED_CTRL
255	USB3_P2_RX_Dn	256	PROCHOT_N
257	GND	258	PCH_EC_ME_CONFIG
259	USB3_P3_TX_Dp	260	RSMRST_N
261	USB3_P3_TX_Dn	262	SYS_RESET_N
263	GND	264	PWRBTN_N
265	USB3_P3_RX_Dp	266	GND
267	USB3_P3_RX_Dn	268	ISH_I2C0_SDA
269	GND	270	ISH_I2C0_SCL
271	USB31_P4_TX_Dp	272	GND
273	USB31_P4_TX_Dn	274	ISH_I2C1_SDA
275	GND	276	ISH_I2C1_SCL
277	USB31_P4_RX_Dp	278	GND
279	USB31_P4_RX_Dn	280	ISH_GPIO_0
281	GND	282	ISH_GPIO_1
283	USB2_P5_Dp	284	ISH_GPIO_2
285	USB2_P5_Dn	286	ISH_GPIO_3
287	GND	288	ISH_GPIO_4/I2C1_IRQ_N
289	USB2_P6_Dp	290	GND
291	USB2_P6_Dn	292	I2C0_SDA
293	GND	294	I2C0_SCL
295	USB2_P7_Dp	296	GND
297	USB2_P7_Dn	298	I2C1_SDA
299	GND	300	I2C1_SCL

3.4 Antenna Connection

The NUC 8 Compute Element wireless module does not have any antennas connected. For wireless and Bluetooth operation appropriate antennas will be required. Depending on the enclosure design internal or external antennas can be supported. Figure 6 shows the location of the two antenna connectors on the Mylar side.

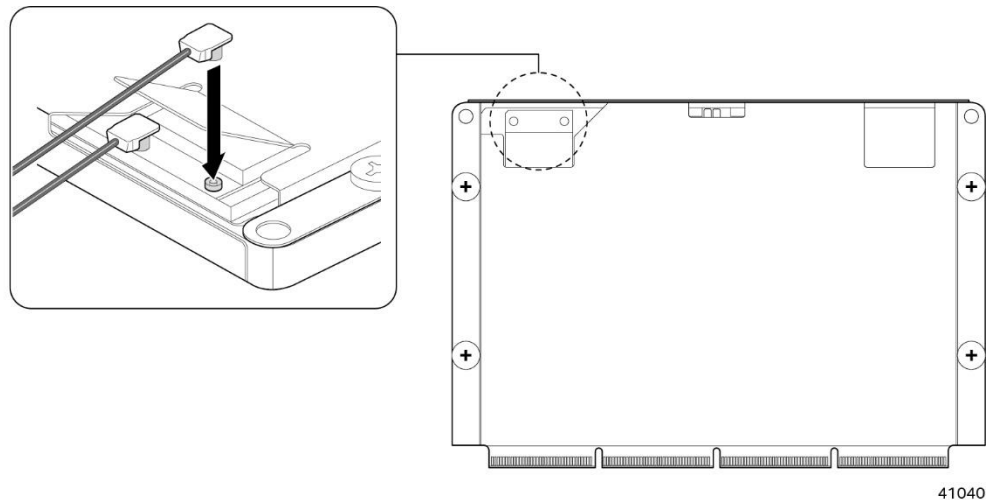

Figure 6. Location of the Antenna Connectors

The wireless module uses a standard 2x2 mm size RF micro coaxial receptacle (connector) with an outer diameter of 1.5 mm as defined in the PCI-E M.2 Specification. Specific plugs should be selected to suit the assembly allowable mating height and cable diameter. Refer to the PCI-E M.2 Specification for the minimum requirements of the compatible RF connectors and mating plugs.

- Receptacle physical outline is 2mm x 2mm x 0.6mm
- Receptacle outer diameter is 1.5mm

3.5 BIOS Security Switch

Figure 7 shows the location of the BIOS Security Switch. The 3-position switch determines the BIOS Security program's mode.



CAUTION

Do not change the switch with the power on. Always turn off the power and unplug the power cord from the carrier board before changing a switch setting. Otherwise, the board could be damaged.

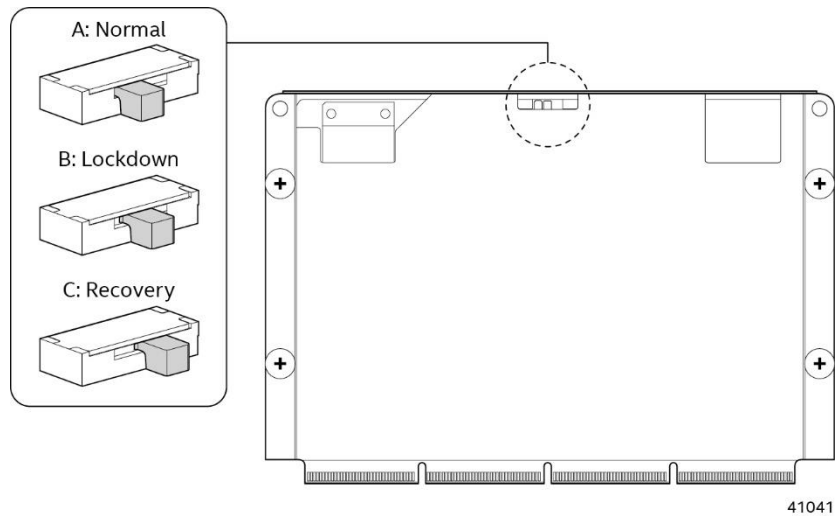

Figure 7. Location of the BIOS Security Switch

Table 8 lists the switch settings for the three modes: normal, lockdown, and recovery/configuration.

Table 8. BIOS Security Switch Settings

Function/Mode	Switch Setting	Configuration
Normal	A	The BIOS uses current configuration information and passwords for booting.
Lockdown	B	<p>The BIOS uses current configuration information and passwords for booting, except:</p> <ul style="list-style-type: none"> All POST Hotkeys are suppressed (prompts are not displayed, and keys are not accepted. For example, F2 for Setup, F10 for the Boot Menu). Power Button Menu is not available. <p>BIOS updates are not available except for automatic Recovery due to flash corruption.</p>
Recovery/Configuration	C	<p>BIOS Recovery Update process if a matching *.CAP file is found. Recovery Update can be cancelled by pressing the Esc key.</p> <p>If the Recovery Update was cancelled or a matching *.CAP file was not found, a Configuration Menu will be displayed. The Configuration Menu consists of the following options:</p> <ul style="list-style-type: none"> [1] Suppress this menu until the BIOS Security Switch is set to normal. [2] Clear BIOS User and Supervisor Passwords. [3] Clear Trusted Platform Module (vPro SKU only) Warning: Data encrypted with the TPM will no longer be accessible if the TPM is cleared [F2] BIOS Setup [F4] BIOS Recovery

3.6 Power

The Intel® NUC 8 Compute Element requires a DC input from the carrier board via the connector. The carrier board must provide the proper voltage and current as listed below:

- Voltage: 5.7-20 V DC +/-5%
- Current (RMS max): 3.0-10.6 A
- Current (Peak): 12 A



CAUTION

It is strongly recommended to make sure that the carrier board power source is disconnected before installing or removing the Intel® NUC 8 Compute Element into the carrier board connector. Installing or removing the Intel® NUC 8 Compute Element while a power source is connected to the carrier board may cause damage to the Intel® NUC 8 Compute Element, operating system corruption, create a no boot condition or result in data loss.

3.7 Mechanical

The following figures illustrate the mechanical form factor for the NUC 8 Compute Element. All dimensions are shown in millimeters (mm).

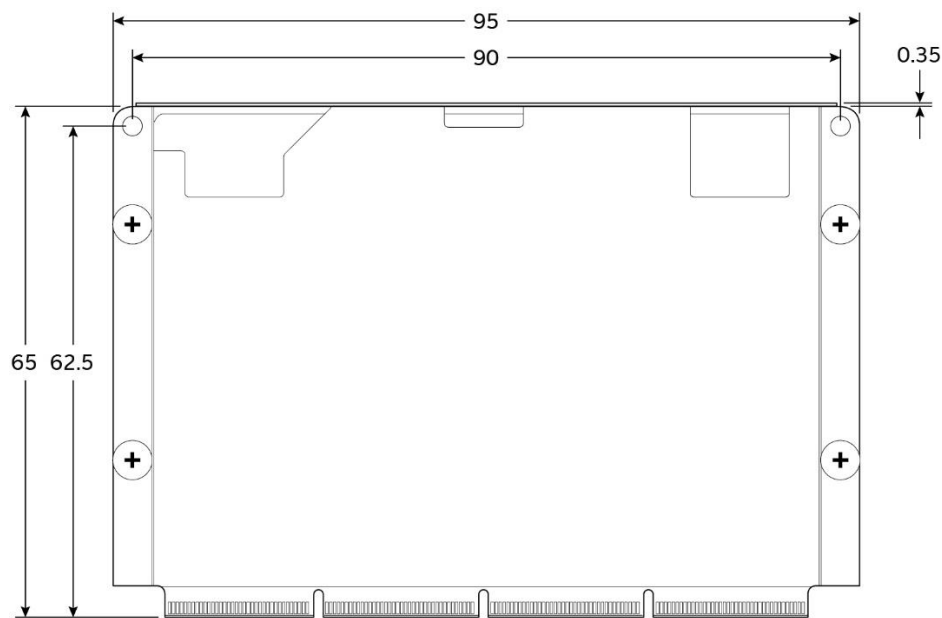

Figure 8. Mylar Side



Figure 9. Integrated Heat Shield Side

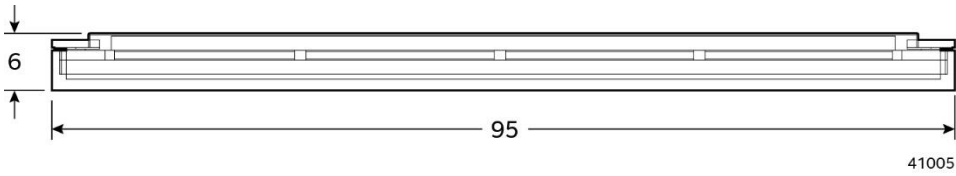

Figure 10. Front (Showing Connector)

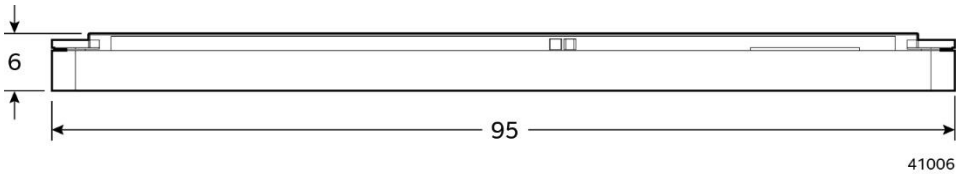

Figure 11. Back

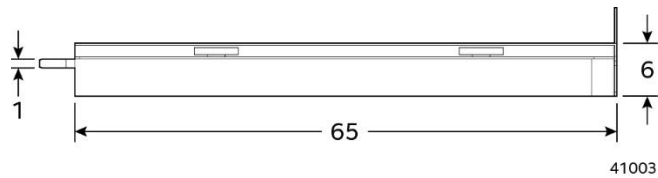
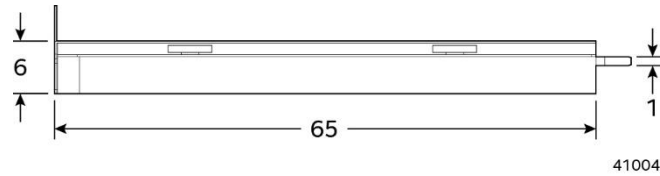

Figure 12. Left

**Figure 13. Right**

3.8 Thermal

The fundamental design of the Intel® NUC 8 Compute Element relies on the carrier board enclosure for proper cooling. Both internal components and external skin temperatures are critical parameters in proper cooling and should be considered in any design. For best cooling performance, direct contact with a thermal management device to the bottom of the Compute Element such as a heatsink or enclosure surface is recommended. This can be accomplished with active or passive cooling design approaches. Non-contact convection only cooling may be possible but will likely result in performance limitations or compromises in skin temperature levels relative to a conductive design approach.

The Integrated Heat Spreader side of the Compute Element is the primary heat source. To provide adequate cooling of the Compute Element while maintaining safe skin temperatures a thermal solution that contacts the entire metal portion of the Integrated Heat Spreader is recommended. Localized contact with the primary heat source on the Compute Element bottom is not recommended as the location is subject to change with different generations of the Compute Element. The Mylar side of the Compute Element does not typically require contact with a thermal solution, however proper air flow over the top of the Compute Element is recommended. The below information is critical for the design of a thermal solution.

- The Thermal Design Power (TDP) of the processors used in the NUC 8 Compute Element is 15W.
- The Power Limit 1 (PL1) default setting in the BIOS of the NUC 8 Compute Element is 15.
- The Junction Temperature Range (T_j) of the processor used in the NUC 8 Compute Element is 0°C -100°C.
- The TDP specification temperature range of the processor used in the NUC 8 Compute Element is 35°C -100°C

3.9 Environmental

Table 9 lists the environmental specifications for the Intel® NUC 8 Compute Element.

Table 9. Environmental Specifications

Parameter	Specification	
Temperature		
Non-Operating	-40 °C to +60 °C	
Operating	Ambient operating temperature limitations are a function of the carrier board and carrier board enclosure design and as such a specific number cannot be provided.	
Shock		
Unpackaged	25 g trapezoidal waveform	
	Velocity change of 250 inches/s ²	
Packaged	Free fall package drop machine set to the height determined by the weight of the package.	
	Product Weight (pounds)	Free Fall (inches)
	<20	36
	21-40	30
	41-80	24
	81-100	18
Vibration		
Unpackaged	5 Hz to 20 Hz: 0.01 g ² /Hz sloping up to 20 Hz @ 0.02 g ² /Hz	
	20 Hz to 500 Hz: 0.02 g ² /Hz (flat)	
	Input acceleration is 3.13 g RMS	
Packaged	40 Hz to 500 Hz: 0.015 g ² /Hz sloping down to 0.00015 g ² /Hz	
	Input acceleration is 1.09 g RMS	

Note: Before attempting to operate the Intel® NUC 8 Compute Element, the overall temperature of the system must be above the minimum operating temperature specified. It is recommended that the system temperature be at least room temperature before attempting to power on the NUC 8 Compute Element. The operating and non-operating environment must avoid condensing humidity.

4 Characterized Errata

This section of the document communicates product Errata for the Intel® NUC 8 Compute Element.

Errata are design defects or deviations from current published specifications for a given product. Published errata may or may not be corrected. Hardware and software designed to be used with any given processor stepping must assume that all errata documented for that process stepping are present on all devices.

There are no characterized errata at this time.

X-ON Electronics

Largest Supplier of Electrical and Electronic Components

Click to view similar products for [Embedded Box Computers](#) category:

Click to view products by [Intel](#) manufacturer:

Other Similar products are found below :

[tBOX312-870-FL-i7-DC](#) [tBOX313-835-FL-RJ-DC](#) [UPOS-3150-R0W0E](#) [ARK-20-S8A1E](#) [R2224WTTYSR](#) [BXNUC9i5QNX](#)
[BXNUC9i5QNX1](#) [BKNUC9V7QNX](#) [BKNUC9V7QNX1](#) [2-A0DF-2001](#) [BKCMB1ABB](#) [BKCMB1ABA](#) [EM3000-3845-8-128-WL-U-1](#)
[TANK-870AI-i5/8G/2A-R10](#) [PRFE21000038](#) [EM5000-I3-8-128-WL-W7-1](#) [EM3000-3845-8-128-WL-W7-1](#) [PRFE21000039](#) [AMOS-825-](#)
[1Q10A1](#) [UPS-EDAI-X70864-U01-DC01](#) [UPX-EDGEI7-A10-1664-F01](#) [MXE-211/M8G](#) [PXIe-3985/M16G](#) [PXIe-3987/M16G/SSD](#) [AIMB-](#)
[T1215DA-00Y0E](#) [AIMB-T12315A-00Y0E](#) [AMAX-5580-54000A](#) [APAX-5580-474AE](#) [ARK-6322-Q0A2E](#) [DS-100GF-S8A1E](#) [DS-100GL-](#)
[S8A1E](#) [EPC-R4680CQ-XAA1E](#) [ESRP-CSS-UNO2484](#) [ITA-1611-10A1E](#) [ITA-1711-10A1E](#) [MIC-710AI-00A1](#) [MIC-720AI-00A1](#) [UNO-247-](#)
[J1N1AE](#) [UTX-3115FS-S6A2E](#) [AMI220AF-4L-7500](#) [ELIT-1200](#) [AIE100-903-FL](#) [EBOX671-517-FL-DC](#) [MVS900-511-FL](#) [AMS200](#) [SE-92-](#)
[I7](#) [SI-606](#) [SI-60E](#) [TANK-760-HM86i-i5/4G-R10](#) [BKCM8i7CB8N](#)