

Intel® NUC Rugged Chassis Element CMCR1ABA, CMCR1ABB and CMCR1ABC Product Specification

Revision 1.3

Regulatory Model: CMCR1AB

July 2020

Intel® NUC Rugged Chassis Element CMCR1ABA, CMCR1ABB or CMCR1ABC may contain design defects or errors known as errata that may cause the product to deviate from published specifications. Current characterized errata, if any, are documented in this product specification.

Revision History

Revision	Revision History	Date
1.0	First release	October 2019
1.01	Title Correction, Ethernet model number correction, Updated Figures 6 and 7	December 2019
1.2	Added CMCR1ABC	June 2020
1.3	Added M.2 connector section and vPro® section.	July 2020

Disclaimer

This product specification applies to only the standard Intel® NUC Rugged Chassis Element with product codes CMCR1ABA, CMCR1ABB and CMCR1ABC.

INFORMATION IN THIS DOCUMENT IS PROVIDED IN CONNECTION WITH INTEL® PRODUCTS. NO LICENSE, EXPRESS OR IMPLIED, BY ESTOPPEL OR OTHERWISE, TO ANY INTELLECTUAL PROPERTY RIGHTS IS GRANTED BY THIS DOCUMENT. EXCEPT AS PROVIDED IN INTEL'S TERMS AND CONDITIONS OF SALE FOR SUCH PRODUCTS, INTEL ASSUMES NO LIABILITY WHATSOEVER, AND INTEL DISCLAIMS ANY EXPRESS OR IMPLIED WARRANTY, RELATING TO SALE AND/OR USE OF INTEL PRODUCTS INCLUDING LIABILITY OR WARRANTIES RELATING TO FITNESS FOR A PARTICULAR PURPOSE, MERCHANTABILITY, OR INFRINGEMENT OF ANY PATENT, COPYRIGHT OR OTHER INTELLECTUAL PROPERTY RIGHT. UNLESS OTHERWISE AGREED IN WRITING BY INTEL, THE INTEL PRODUCTS ARE NOT DESIGNED NOR INTENDED FOR ANY APPLICATION IN WHICH THE FAILURE OF THE INTEL PRODUCT COULD CREATE A SITUATION WHERE PERSONAL INJURY OR DEATH MAY OCCUR.

All Intel® NUC Rugged Chassis Elements are evaluated as Information Technology Equipment (I.T.E.) for use in personal computers (PC) for installation in homes, offices, schools, computer rooms, and similar locations. The suitability of this product for other PC or embedded non-PC applications or other environments, such as medical, industrial, alarm systems, test equipment, etc. may not be supported without further evaluation by Intel.

Intel Corporation may have patents or pending patent applications, trademarks, copyrights, or other intellectual property rights that relate to the presented subject matter. The furnishing of documents and other materials and information does not provide any license, express or implied, by estoppel or otherwise, to any such patents, trademarks, copyrights, or other intellectual property rights.

Intel may make changes to specifications and product descriptions at any time, without notice.

Designers must not rely on the absence or characteristics of any features or instructions marked "reserved" or "undefined." Intel reserves these for future definition and shall have no responsibility whatsoever for conflicts or incompatibilities arising from future changes to them.

Intel processor numbers are not a measure of performance. Processor numbers differentiate features within each processor family, not across different processor families: Go to:

[Learn About Intel® Processor Numbers](#)

Intel® NUC Rugged Chassis Elements may contain design defects or errors known as errata, which may cause the product to deviate from published specifications. Current characterized errata are available on request.

Contact your local Intel sales office or your distributor to obtain the latest specifications before placing your product order.

Intel, the Intel logo and Intel Core are trademarks of Intel Corporation in the U.S. and/or other countries.

* Other names and brands may be claimed as the property of others.

Copyright © 2020 Intel Corporation. All rights reserved.

Preface

This Product Specification specifies the layout, components, connectors, power and environmental features for the Intel® NUC Rugged Chassis Element



NOTE

In this document, the use of "Intel® NUC Rugged Chassis Element" will refer to the CMCR1ABA, CMCR1ABB and CMCR1ABC versions of the Intel® NUC Rugged Chassis Element.

Intended Audience

The document is intended to provide technical information about Intel® NUC Rugged Chassis Element and its components to the vendors, system integrators, and other engineers and technicians who need this level of information. It is specifically *not* intended for general audiences.

What This Document Contains

Chapter	Description
1	A description of the Intel® NUC Rugged Chassis Element features
2	A technical description of the Intel® NUC Rugged Chassis Element

Typographical Conventions

This section contains information about the conventions used in this specification. Not all of these symbols and abbreviations appear in all specifications of this type.

Notes, Cautions, and Warnings



NOTE

Notes call attention to important information.



CAUTION

Cautions are included to help you avoid damaging hardware or losing data.

Other Common Notation

#	Used after a signal name to identify an active-low signal (such as USBP0#)
GB	Gigabyte (1,073,741,824 bytes)
GB/s	Gigabytes per second
Gb/s	Gigabits per second
KB	Kilobyte (1024 bytes)
Kb	Kilobit (1024 bits)
kb/s	1000 bits per second
MB	Megabyte (1,048,576 bytes)
MB/s	Megabytes per second
Mb	Megabit (1,048,576 bits)
Mb/s	Megabits per second
TDP	Thermal Design Power
Xxh	An address or data value ending with a lowercase h indicates a hexadecimal value.
x.x V	Volts. Voltages are DC unless otherwise specified.
*	This symbol is used to indicate third-party brands and names that are the property of their respective owners.

Intel® NUC Rugged Chassis Element Identification Information

NUC Rugged Chassis Element Identification Information

SA Revision	Product Code	Chassis Type	AC Cord	Notes
K53776-202	BKCMCR1ABA	Expandable	None	1
K53776-202	BKCMCR1ABA1	Expandable	US	1
K53776-202	BKCMCR1ABA2	Expandable	EU	1
K53778-202	BKCMCR1ABB	Dual LAN	None	1
K53778-202	BKCMCR1ABB1	Dual LAN	US	1
K53778-202	BKCMCR1ABB2	Dual LAN	EU	1
K53784-302	BKCMCR1ABC	Six HDMI	None	1
K53784-302	BKCMCR1ABC1	Six HDMI	US	1
K53784-302	BKCMCR1ABC2	Six HDMI	EU	1

Notes:

1. The SA number is found on the bottom of the chassis

Specification Changes or Clarifications

The table below indicates the Specification Changes or Specification Clarifications that apply to the Intel® NUC Rugged Chassis Element CMCR1ABA, CMCR1ABB and CMCR1ABC.

Specification Changes or Clarifications

Date	Type of Change	Description of Changes or Clarifications
		•

Errata

Current characterized errata, if any, will be documented in Section 3 of this Product Specification.

Contents

Revision History	ii
Disclaimer	ii
Preface	iii
Intended Audience.....	iii
What This Document Contains	iii
Typographical Conventions	iii
Intel® NUC Rugged Chassis Element Identification Information.....	v
Specification Changes or Clarifications.....	vi
Errata.....	vi
Contents	vii
1 Product Description	9
1.1 Overview	9
1.2 Version Summary.....	9
1.3 Feature Summary.....	10
2 Technical Reference	11
2.1 Block Diagrams.....	11
2.2 Features.....	14
2.2.1 CMCR1ABC HDMI Port Configuration	16
2.3 Power.....	17
2.4 M.2 Connectors	17
2.5 Intel® vPro® Technology	17
2.6 Serial Port Headers.....	18
2.7 Display Emulation	19
2.8 Wireless Enable/Disable Jumper	20
2.9 Mechanical	21
2.10 Thermal	22
2.11 Environmental	23
3 Characterized Errata	24
Figures	
Figure 1. CMCR1ABA Block Diagram.....	11
Figure 2. CMCR1ABB Block Diagram.....	12
Figure 3. CMCR1ABC Block Diagram.....	13
Figure 4. CMCR1ABA/CMCR1ABB/CMCR1ABC Front Panel	14
Figure 5. CMCR1ABA Back Panel.....	14
Figure 6. CMCR1ABB Back Panel.....	15

Figure 7. CMCR1ABC Back Panel.....	15
Figure 8. CMCR1ABC HDMI Port Configuration.....	16
Figure 9. Serial Port Header Location.....	18
Figure 10. Wireless Enable/Disable Jumper Location.....	20
Figure 11. CMCR1ABA, CMB1ABB and CMCR1ABC Dimensions	21
Figure 12. VESA Bracket Dimensions	22

Tables

Table 1. Chassis Version Summary	9
Table 2. Feature Summary	10
Table 3. CMCR1ABA/CMCR1ABB/CMCR1ABC Front Panel Connectors.....	14
Table 4. CMCR1ABABack Panel Connectors	14
Table 5. CMCR1ABB Back Panel Connectors	15
Table 6. CMCR1ABC Back Panel Connectors	15
Table 7. HDMI Port Configuration and Supported Resolutions	16
Table 8. Serial Port Header Pinout	18
Table 9. Wireless Enable/Disable Jumper Settings.....	20
Table 10. Environmental Specifications.....	23

1 Product Description

1.1 Overview

The Intel® NUC Rugged Chassis Element is a rugged chassis solution for the Intel® NUC Rugged Board Element and consists of a NUC Rugged Board Element that is designed for the Intel® NUC Compute Element to plug into along with input/output connectors and headers. The Chassis provides a passive enclosure for the NUC Compute Element and the NUC Rugged Board Element.

The Intel® NUC Rugged Chassis Element require a compatible Intel® NUC Compute Element in order to operate.

For information on compatible devices for use with the Intel® NUC Rugged Chassis Element see <http://www.intel.com/NUCElements>.

1.2 Version Summary

There are three different chassis versions of this model of Intel® NUC Rugged Chassis Element available which are summarized in Table 1. Unless otherwise noted in this document, not all features are available on all versions of the Intel® NUC Rugged Chassis Element.

Table 1. Chassis Version Summary

Version	HDMI Ports	M.2 Connectors	LAN	USB 2 Ports	USB 3 Ports	USB 2.0 Headers	USB 3.0 Headers	Serial Port Headers
CMCR1ABA	2	2	1	1	3	2	1	2
CMCR1ABB	2	2	2	3	3	0	1	2
CMCR1ABC	6	2	1	1	3	2	1	2



NOTE

Intel® NUC Rugged Chassis Elements listed in Table 1 have been certified for use as a component in Information Technology Equipment in certain countries. The system integrator is responsible for testing and acquiring any additional country-specific regulatory approvals, including all system-wide certifications.

To find information about...

Intel® NUC Compute Element
 Intel® NUC Rugged Chassis Element Support
 Intel® NUC Element Warranty Information
 Available configurations for Intel® NUC Rugged Chassis Element
 Intel Processors
 Intel Graphics
 Intel Wireless
 Intel Technologies

Visit this World Wide Web site:

<https://www.intel.com/NUCElements>
<https://www.intel.com/NUCElementsSupport>
<http://www.intel.com/NUCWarranty>
<https://ark.intel.com>
<https://www.intel.com/processors>
<https://www.intel.com/graphics>
<https://www.intel.com/wireless>
<https://www.intel.com/technology>

1.3 Feature Summary

Table 2 summarizes the major features of the Intel® NUC Rugged Chassis Elements.

Table 2. Feature Summary

Chassis Size	254 millimeters by 152.4 millimeters by 36 millimeters
Graphics Outputs	<p>Integrated graphics support with Intel® HD Graphics Technology</p> <ul style="list-style-type: none"> • Two HDMI 2.0a • Four HDMI 1.4 on CMC1ABC • Built in CEC for all HDMI ports • High-Bandwidth Digital Content Protection support for content protection <ul style="list-style-type: none"> ○ HDCP 1.4 and 2.2 supported via HDMI • Resolutions and refresh rates supported <ul style="list-style-type: none"> ○ Up to 4K @ 60Hz ○ Up to 1080p @ 120Hz
Audio	Intel® High Definition (Intel® HD) Audio via HDMI
Storage	<ul style="list-style-type: none"> • One M.2 22x80 Key M slot for PCIe x4 NVMe or SATA SSDs • One M.2 22x80 Key M slot for PCIe x4 NVMe or PCIe add in devices
Wireless LAN	Intel® NUC Compute Element supplies the solution, antennas provided
Wired LAN	<ul style="list-style-type: none"> • Intel® Ethernet Connection I219-LM (Support for Intel® vPro™ Technology when using a vPro™ enabled NUC Compute Element) • Intel® Ethernet Controller I211-AT (CMB1ABB only)
USB 2.0 Ports	<ul style="list-style-type: none"> • CMC1ABA: 1 Front Panel • CMC1ABB: 3 (1 Front Panel, 2 Back Panel) • CMC1ABC: 1 Front Panel
USB 3.x¹ Ports	3 (1 Front Panel, 2 Back Panel)
Serial Port Header	2 Internal Headers (can be used on CMC1ABA expandable back panel)
Operating Systems Support (64-bit only)	<ul style="list-style-type: none"> • Windows* 10 Home • Windows 10 Pro • Windows 10 Enterprise • Windows 10 Education • Windows 10 IoT Enterprise • Some Linux* operating systems may be compatible. Check with the specific Linux distribution to make sure that support is available for this platform.
Connector Supported	<ul style="list-style-type: none"> • Lotes APC10468-P001A01 Edge Mount Connector
Thermal Solution	Passive
Sustained Operation (24x7 usage)	Sustained Operation is defined as 24x7 operation for 5 years with 50% system utilization on average, with an expected service rate of 1% per year during this period.
Dust Protection	IP50 as defined in IEC 60529 (Ed. 2.1), clause 4.1.

¹ USB 3.x port speed is determined by the Intel® NUC Compute Element.

2 Technical Reference

2.1 Block Diagrams

Figure 1 is a block diagram of the major functional areas of the NUC Rugged Chassis Element CMC11ABA.

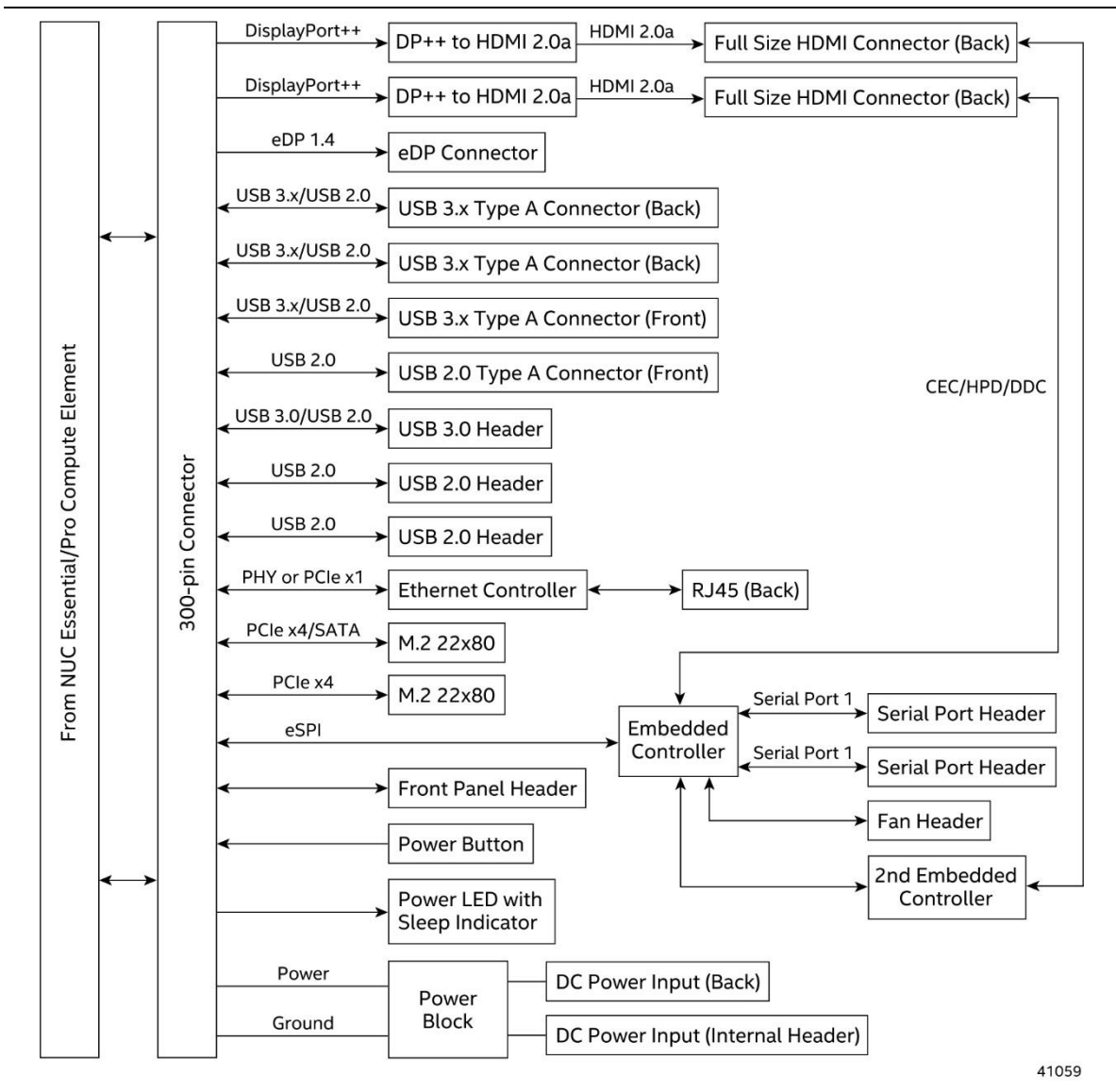

41059

Figure 1. CMC11ABA Block Diagram

Figure 2 is a block diagram of the major functional areas of the NUC Rugged Chassis Element CMC1ABB.

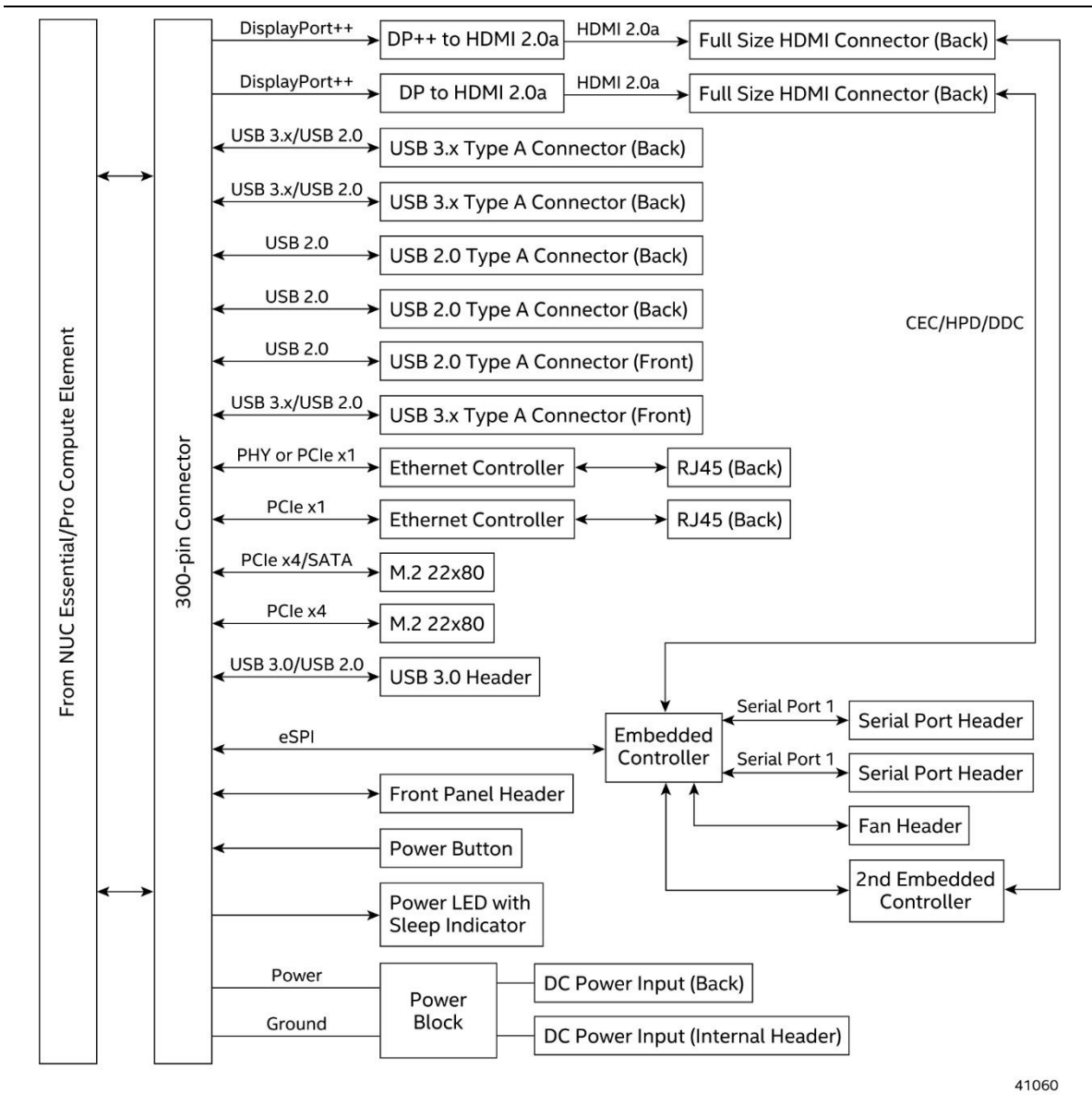
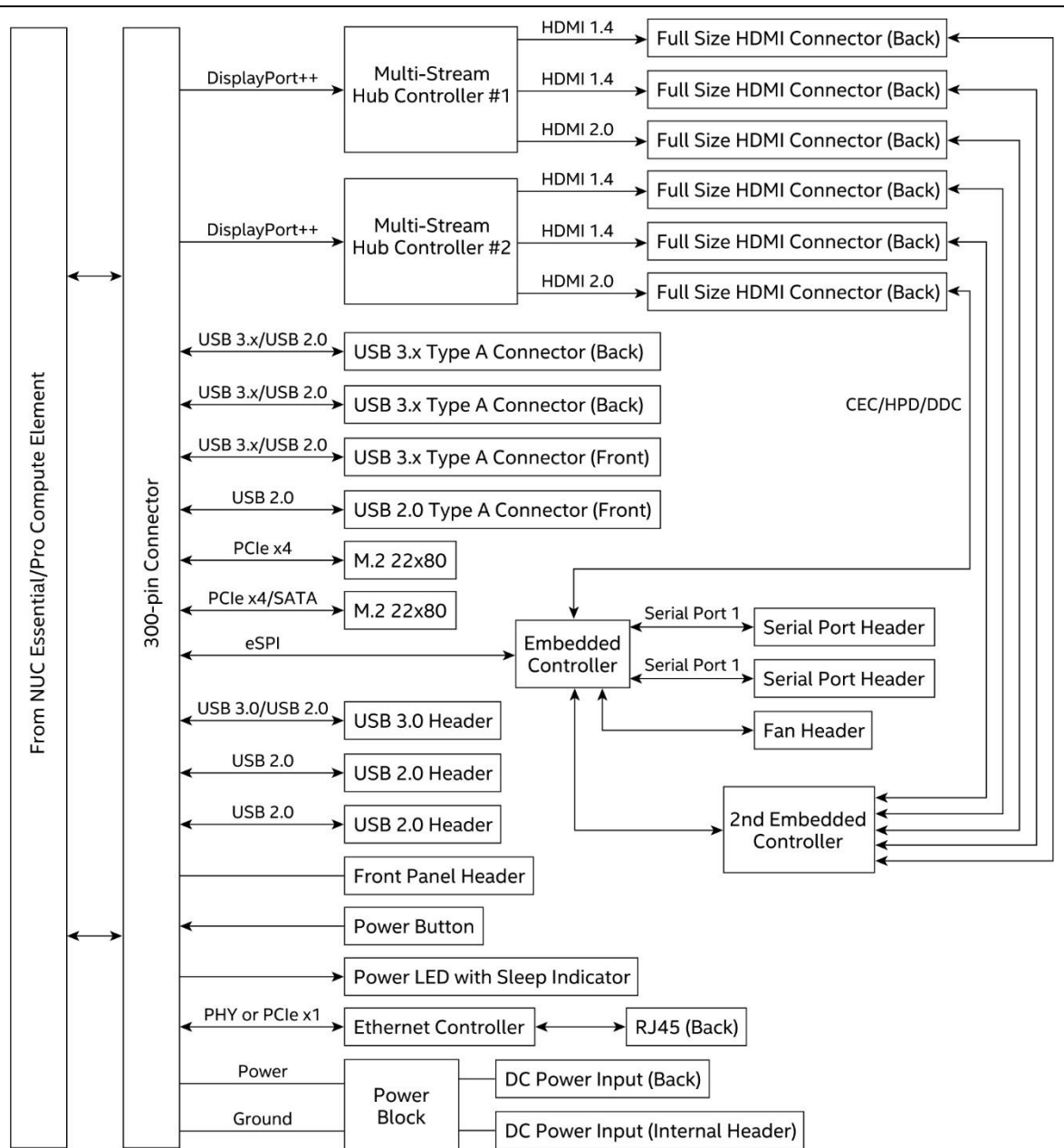

Figure 2. CMC1ABB Block Diagram

Figure 3 is a block diagram of the major functional areas of the NUC Rugged Chassis Element CMC1ABC.



41061

Figure 3. CMC1ABC Block Diagram

2.2 Features

The NUC Rugged Chassis Elements have front panel and the back panel input/output connectors. See the below figures for the locations of the connectors.

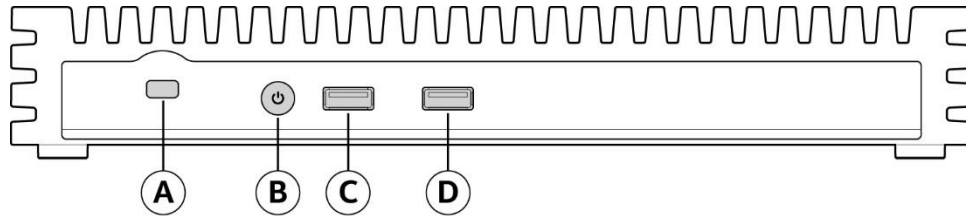

41050

Figure 4. CMCR1ABA/CMCR1ABB/CMCR1ABC Front Panel

Table 3. CMCR1ABA/CMCR1ABB/CMCR1ABC Front Panel Connectors

Item	Description	Item	Description
A	Anti-Theft Key Lock Hole	C	USB 3.x ¹ Port
B	Power Button	D	USB 2.0 Port

¹ USB 3.x port speed is determined by the Intel® NUC Pro Compute Element.

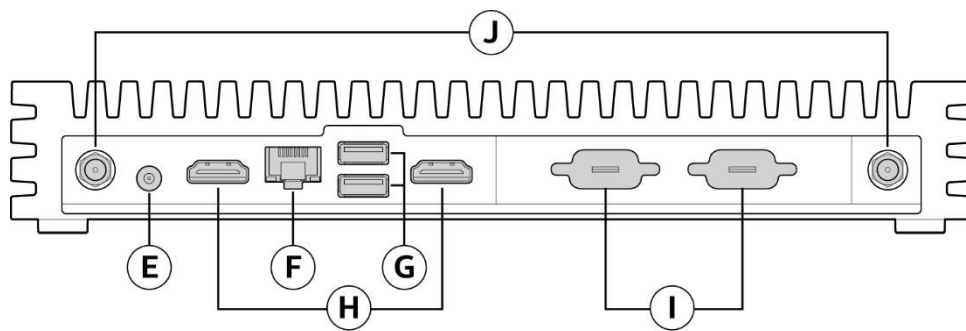

41051

Figure 5. CMCR1ABA Back Panel

Table 4. CMCR1ABABack Panel Connectors

Item	Description	Item	Description
E	Power Input Jack	H	HDMI Ports
F	Ethernet Connector (RJ-45)	I	Expandable Back Panel ²
G	USB 3.x ¹ Ports	J	Antenna Connectors

¹ USB 3.x port speed is determined by the Intel® NUC Pro Compute Element.

² The expandable back panel area has cut outs for two DB9 serial port connectors. The expansion area back plate can be replaced with a custom designed expansion back panel plate for use with other connector types. Custom designed expansion back panel plates are not offered by Intel. To use the other headers that are available for this purpose, refer to the Intel® NUC Rugged Board Element Product Specification.

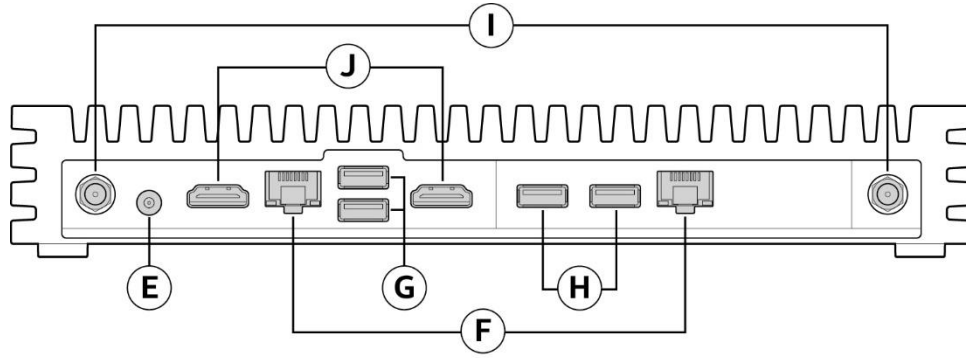

41052

Figure 6. CMC11ABB Back Panel

Table 5. CMC11ABB Back Panel Connectors

Item	Description	Item	Description
E	Power Input Jack	H	USB 2.0 Ports
F	Ethernet Connectors (RJ-45)	I	Antenna Connectors
G	USB 3.x ¹ Ports	J	HDMI Ports

¹ USB 3.x port speed is determined by the Intel® NUC Pro Compute Element.

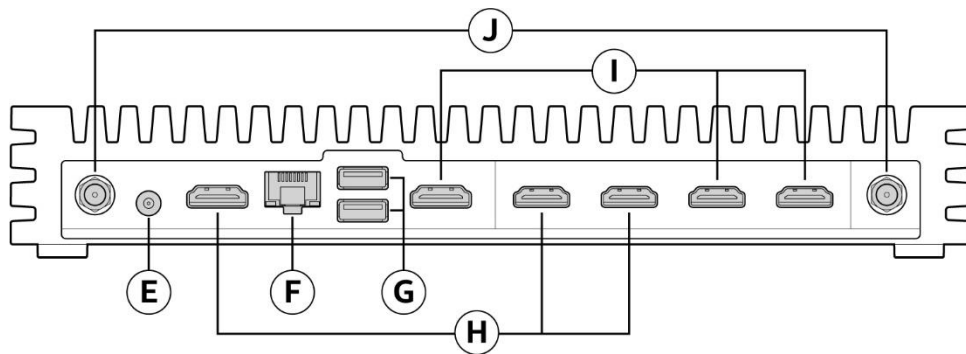

41080

Figure 7. CMC11ABC Back Panel

Table 6. CMC11ABC Back Panel Connectors

Item	Description	Item	Description
E	Power Input Jack	H	HDMI Ports A ²
F	Ethernet Connector (RJ-45)	I	HDMI Ports B ³
G	USB 3.x ¹ Ports	J	Antenna Connectors

¹ USB 3.x port speed is determined by the Intel® NUC Pro Compute Element.

² Group A HDMI ports are configured from left to right as A, A3 and A2.

³ Group B HDMI ports are configured from left to right as B, B2 and B3.

2.2.1 CMCR1ABC HDMI Port Configuration

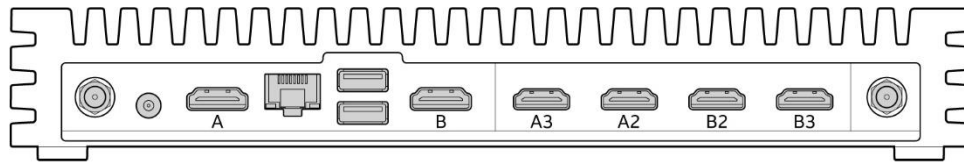

41082

Figure 8. CMCR1ABC HDMI Port Configuration

Table 7. HDMI Port Configuration and Supported Resolutions

Configuration	HDMI A	HDMI B	HDMI A3	HDMI A2	HDMI B2	HDMI B3
1	4K@60					
2	1080@120		1080@120			
3	1080@120			1080@120		
4			1080@120	1080@120		
5	1080@60		1080@60	1080@60		
6		4K@60				
7		1080@120			1080@120	
8		1080@120				1080@120
9					1080@120	1080@120
10		1080@60			1080@60	1080@60
11	4K@60	4K@60				
12	1080@120	4K@60	1080@120			
13	1080@120	4K@60		1080@120		
14		4K@60	1080@120	1080@120		
15	1080@60	4K@60	1080@60	1080@60		
16	4K@60	1080@120			1080@120	
17	4K@60	1080@120				1080@120
18	4K@60				1080@120	1080@120
19	4K@60	1080@60			1080@60	1080@60
20	1080@120	1080@120	1080@120		1080@120	
21	1080@120	1080@120		1080@120		1080@120
22			1080@120	1080@120	1080@120	1080@120
23	1080@60	1080@60	1080@60	1080@60	1080@60	1080@60

2.3 Power

The Intel® NUC Rugged Chassis Element uses a supplied AC to DC power adapter with a six-foot attached cable with a barrel connector.

- 90-264 Volts AC input, 47-63 Hz
- 19 Volts 4.74 Amps DC output
- 3-pin AC power cord (options include no AC power cord, US AC power cord or EU AC power cord)
- Delayed AC start is supported



CAUTION

It is strongly recommended to make sure that the NUC Rugged Chassis Element is powered off and AC power is removed before removing the NUC Pro Compute Element from the board connector. Removing the NUC Pro Compute Element from the board connector while powered on may cause damage to the NUC Pro Compute Element, operating system corruption, create a no boot condition or result in data loss. If the Blue LED on the board is illuminated, do not remove the NUC Compute Element from the board connector.

2.4 M.2 Connectors

The NUC Rugged Chassis Element has 2 M.2 connectors.

- The M.2 connector parallel to the 300-pin connector has support for both PCIe NVMe and SATA storage solutions.
- The M.2 connector perpendicular to the 300-pin connector has support for PCIe NVMe storage solutions only.

2.5 Intel® vPro® Technology

Intel® vPro™ Technology is a collection of platform capabilities that support enhanced manageability, security, virtualization and power efficiency.

For information about	Refer to
Intel® vPro® Technology	http://support.intel.com/support/vpro/



NOTE

Intel® vPro® Technology is only supported on the Intel® NUC Rugged Board Element if an Intel NUC Compute Element with Intel® vPro® Technology support is connected.

2.6 Serial Port Headers

The NUC Rugged Chassis Element has two white, 1x9, 1.25mm pitch Serial Port headers. See Figure 9 for the location of the two headers. Cutouts are available (Figure 5) on the CMCR1ABA expandable back panel for the addition of two DB9 serial port connectors.

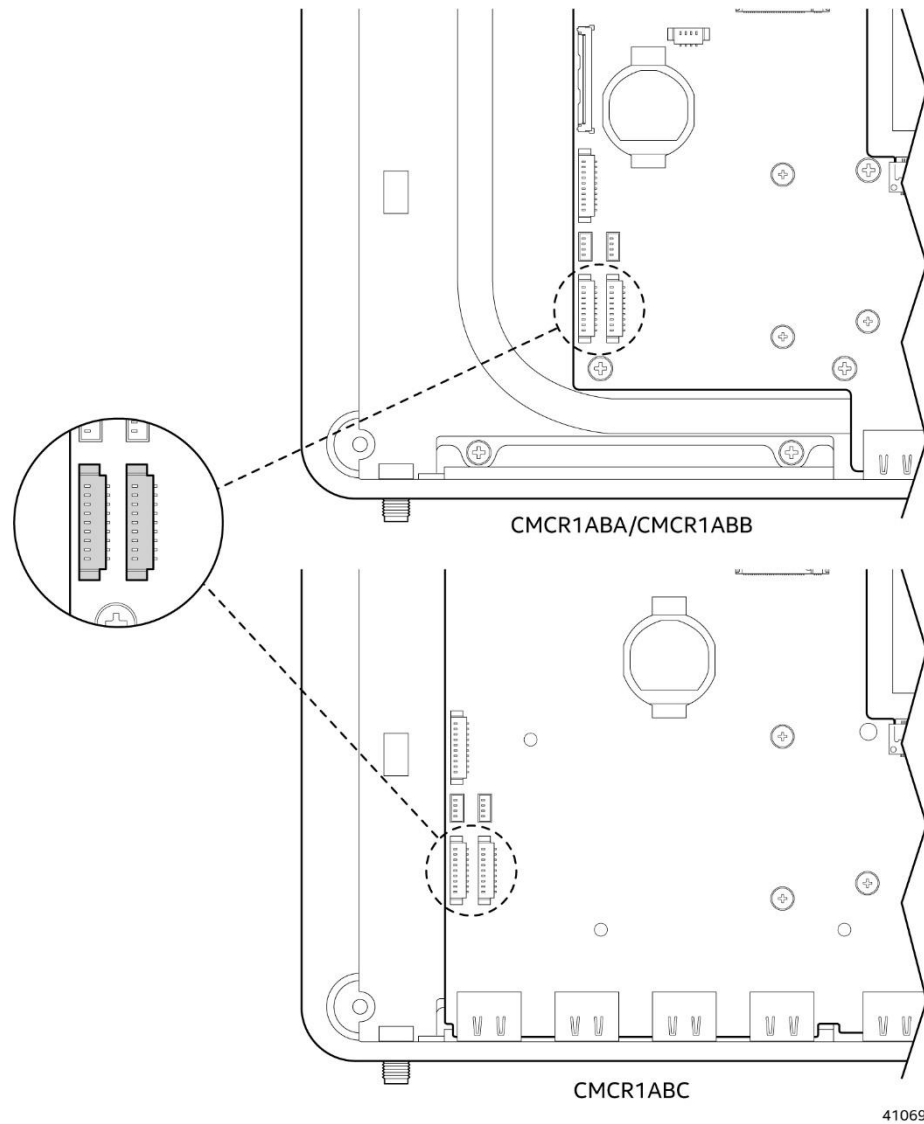

Figure 9. Serial Port Header Location

Table 8. Serial Port Header Pinout

Pin	Signal Name	Description	Pin	Signal Name	Description
1	DCD	Data Carrier Detect	6	DSR	Data Set Ready
2	RXD#	Receive Data	7	RTS	Request to Send
3	TXD#	Transmit Data	8	CTS	Clear to Send
4	DTR	Data Terminal Ready	9	RI	Ring Indicator
5	GND	Ground			

2.7 Display Emulation

The Intel® NUC Rugged Chassis Element supports emulation of displays using the HDMI ports so that the system may be remotely accessed in a headless configuration or be capable of tolerating display connectivity interruptions without the operating system redetecting and rearranging the overall display layout. The display emulation feature may be enabled in Intel® NUC Compute Element BIOS Setup (Advanced → Video → “Display Emulation” drop down menu) with the following options:

- “No display emulation” (default selection): the system operates normally.
- “Virtual display emulation”: provides a 1280x1024 virtual display when no displays are connected to the system and provides an additional 1280x1024 virtual display if one display is attached to the system. If two display are attached to the system these displays will be enabled and no virtual displays will be provided.
- “Persistent display emulation”: emulates that both displays are always connected to the system no matter their actual connection status. The EDID information from each display will remain programmed through S3, S4, and S5 power states until the feature is disabled or a power cycle event (G3 global state) occurs.
 - When “Persistent display emulation” is enabled another drop-down menu (“Inconsistent Display Device”) will become visible that allows the user to select the behavior of the system when the display device EDID is inconsistent with the EDID stored by the system.
 - “Block boot” (default selection): the BIOS will display a warning message with options and will wait indefinitely for a user selection.
 - “Countdown”: the BIOS will display a warning message with options and will wait 10 seconds before booting.



NOTE

“Persistent display emulation” is not compatible with HDCP 2.2 displays.

When using “Persistent display emulation” it would be expected behavior for the system not to properly drive displays different than those connected when the feature was enabled, as the EDID parameters of the initially connected displays are still being driven by the system. A power cycle (AC power loss) is required to retrain the system with a different display configuration.

2.8 Wireless Enable/Disable Jumper

CAUTION

Do not change the jumper with the power on. Always turn off the power and unplug the power cord from the carrier board before changing a jumper setting. Otherwise, the board could be damaged.

The jumper position determines whether the wireless module on the NUC Pro Compute Element is enabled or disabled. See Figure 10 for the location of the jumper. Table 9 describes the jumper settings.

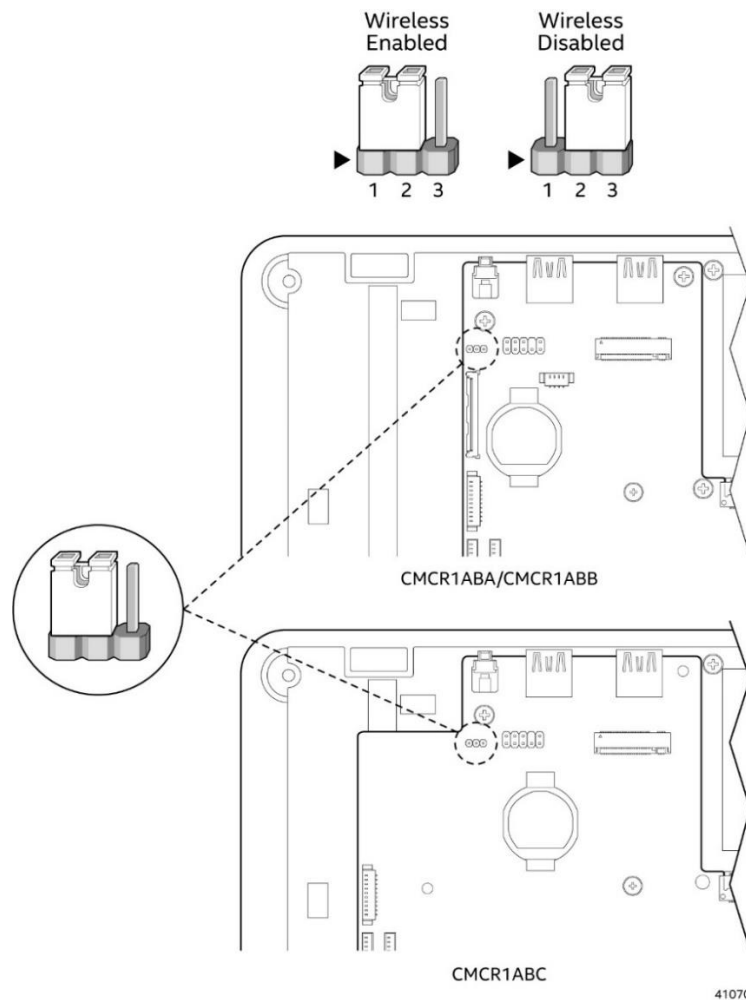

Figure 10. Wireless Enable/Disable Jumper Location

Table 9. Wireless Enable/Disable Jumper Settings

Function/Mode	Jumper Setting	Configuration
Enable	1-2	Wireless and Bluetooth will be enabled on the NUC Pro Compute Element
Disable	2-3	Wireless and Bluetooth will be disabled on the NUC Pro Compute Element

2.9 Mechanical

The following figures illustrate the mechanical form factor of the Intel® NUC Rugged Chassis Element along with the VESA bracket. Dimensions are given in millimeters (mm).

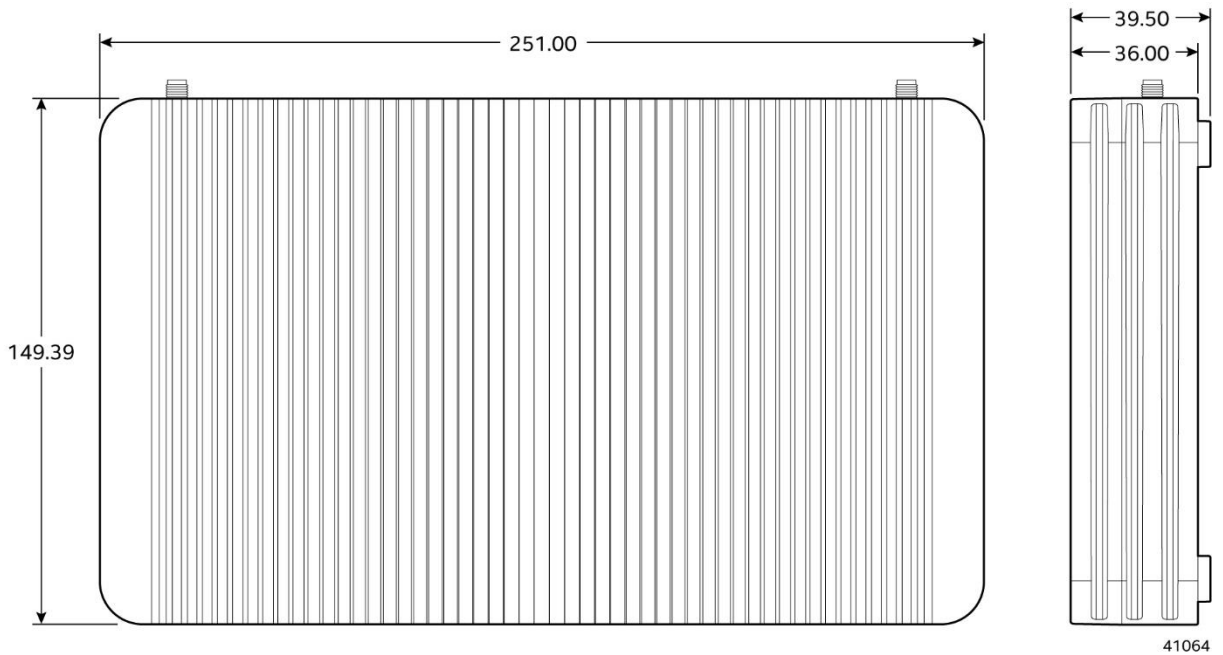

Figure 11. CMCR1ABA, CMB1ABB and CMCR1ABC Dimensions

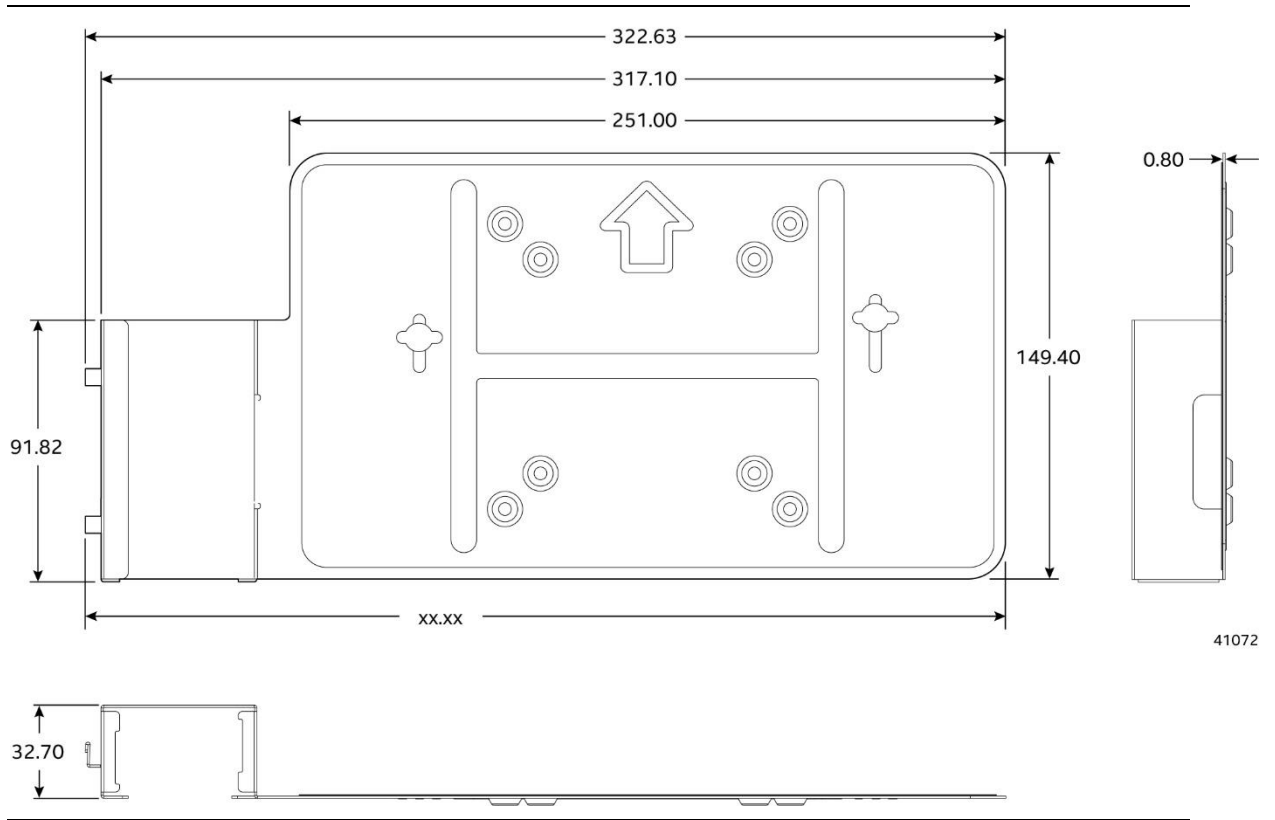

Figure 12. VESA Bracket Dimensions

2.10 Thermal

The Intel® NUC Rugged Chassis Element comes with a complete thermal solution for the Intel® NUC Pro Compute Element. The thermal solution includes a cold plate with thermal interface material, heat pipes and uses the chassis as the heat sink.

2.11 Environmental

Table 10 lists the environmental specifications for the Intel® NUC Rugged Chassis Elements.

Table 10. Environmental Specifications

Parameter	Specification	
Temperature		
Non-Operating	-40 °C to +60 °C	
Operating (Board)	0 °C to +40 °C	
Operating (Chassis)	0 °C to +40 °C	
Shock (Board)		
Unpackaged	25 g trapezoidal waveform	
	Velocity change of 250 inches/s ²	
Packaged	Free fall package drop machine set to the height determined by the weight of the package.	
	Product Weight (pounds)	Free Fall (inches)
	<20	36
	21-40	30
	41-80	24
	81-100	18
Vibration (Chassis)		
Unpackaged	5 Hz to 20 Hz: 0.001 g ² /Hz sloping up to 20 Hz @ 0.01 g ² /Hz	
	20 Hz to 500 Hz: 0.01 g ² /Hz (flat)	
	Input acceleration is 2.20 g RMS	
Packaged	5 Hz to 40 Hz: 0.015 g ² /Hz (flat)	
	40 Hz to 500 Hz: 0.015 g ² /Hz sloping down to 0.00015 g ² /Hz	
	Input acceleration is 1.09 g RMS	

Note: Before attempting to operate this Intel® NUC Rugged Chassis Element, the overall temperature of the system must be above the minimum operating temperature specified. It is recommended that the NUC Rugged Chassis Element temperature be at least room temperature before attempting to power on the system. The operating and non-operating environment must avoid condensing humidity.

3 Characterized Errata

This section of the document communicates product Errata for the Intel® NUC Pro Board Element CMCR1ABA, CMCR1ABB and CMCR1ABC.

Errata are design defects or deviations from current published specifications for a given product. Published errata may or may not be corrected. Hardware and software designed to be used with any given processor stepping must assume that all errata documented for that process stepping are present on all devices.

There are no known characterized errata.

X-ON Electronics

Largest Supplier of Electrical and Electronic Components

Click to view similar products for [Modules Accessories](#) category:

Click to view products by [Intel](#) manufacturer:

Other Similar products are found below :

[7010-0001](#) [AX98219](#) [A1UL8RISER](#) [F1UJPMICRISER](#) [FHW1U16RISER](#) [20-101-0440](#) [MBCDROM](#) [AX61221TM](#) [VM-105](#) [EA](#)
[CARREDIPTFT02](#) [RK-210E-B](#) [E226171106](#) [88606200030E](#) [SI-HDMI-EDID-EM](#) [MIC-75M13-00A1E](#) [FPM-1000T-SMKE](#) [AMK-R004E](#)
[96FMCF-ST2ADAPTER1](#) [AHWKPTP12GBGB](#) [AXXSTCPUCAR](#) [FPK-07-R10](#) [Mini Din 6P to 6P HARNESS](#) [FPF1320 POWER](#)
[MULTIPLEXER CARRIER](#) [881261510A0E](#) [AXXP3SWX08080](#) [conga-B7XD/CSP-Cu-B](#) [881281021A0E](#) [HFT for mounting KIT](#)
[FN928X_FN929X](#) [BB-MH112-1A](#) [15100600](#) [9-5000-1116](#) [BKCMCR1ABB](#) [70763](#) [98R3612003E](#) [881261910A0E](#) [106897](#) [48222R](#) [4D](#)
[ARDUINO ADAPTOR SHIELD II](#) [20926110901](#) [PYCASE GREEN](#) [PYCASE BLUE](#) [FP15072_ZORYA-SC-HEKLA](#) [20952000004](#)
[20953000007](#) [DP-DVI-R10](#) [575-BBIS](#) [RACK-220GW/A130B](#) [492-BBKM](#) [IP411](#) [70760](#)