



# Intel<sup>®</sup> Xeon<sup>®</sup> Processor E5-2400 v3 Product Family

Datasheet, Volume One: Electrical

---

Volume 1 of 2

January 2015



You may not use or facilitate the use of this document in connection with any infringement or other legal analysis concerning Intel products described herein. You agree to grant Intel a non-exclusive, royalty-free license to any patent claim thereafter drafted which includes subject matter disclosed herein.

All information provided here is subject to change without notice. Contact your Intel representative to obtain the latest Intel product specifications and roadmaps.

Intel technologies may require enabled hardware, specific software, or services activation. Check with your system manufacturer or retailer.

No license (express or implied, by estoppel or otherwise) to any intellectual property rights is granted by this document.

The Intel® Xeon® Processor E5-2400 v3 Product Family may contain design defects or errors known as errata which may cause the product to deviate from published specifications. Current characterized errata are available on request.

Contact your local Intel® sales office or your distributor to obtain the latest specifications and before placing your product order.

Copies of documents which have an order number and are referenced in this document, or other Intel literature, may be obtained by calling 1-800-548-4725, or go to: [http://www.intel.com/#/en\\_US\\_01](http://www.intel.com/#/en_US_01)

Hyper-Threading Technology requires a computer system with a processor supporting HT Technology and an HT Technology enabled chipset, BIOS and operating system. Performance will vary depending on the specific hardware and software you use. For more information including details on which processors support HT Technology, see [http://www.intel.com/products/ht/hyperthreading\\_more.htm](http://www.intel.com/products/ht/hyperthreading_more.htm).

Enabling Execute Disable Bit functionality requires a PC with a processor with Execute Disable Bit capability and a supporting operating system. Check with your PC manufacturer on whether your system delivers Execute Disable Bit functionality.

Intel® Virtualization Technology requires a computer system with an enabled Intel® processor, BIOS, virtual machine monitor (VMM) and, for some uses, certain computer system software enabled for it. Functionality, performance or other benefits will vary depending on hardware and software configurations and may require a BIOS update. Software applications may not be compatible with all operating systems. Please check with your application vendor.

Intel® Turbo Boost Technology requires a PC with a processor with Intel Turbo Boost Technology capability. Intel Turbo Boost Technology performance varies depending on hardware, software and overall system configuration. Check with your PC manufacturer on whether your system delivers Intel Turbo Boost Technology. For more information, see <http://www.intel.com/technology/turboboost>.

No computer system can provide absolute security under all conditions. Intel® Trusted Execution Technology (Intel® TXT) requires a computer with Intel® Virtualization Technology, an Intel TXT-enabled processor, chipset, BIOS, Authenticated Code Modules and an Intel TXT-compatible measured launched environment (MLE). Intel TXT also requires the system to contain a TPM v1.s. For more information, visit <http://www.intel.com/technology/security>

The Processor Spec Finder at <http://ark.intel.com> or contact your Intel representative for more information.

64-bit computing on Intel architecture requires a computer system with a processor, chipset, BIOS, operating system, device drivers and applications enabled for Intel® 64 architecture. Performance will vary depending on your hardware and software configurations. Consult with your system vendor for more information.

Δ Intel processor numbers are not a measure of performance. Processor numbers differentiate features within each processor family, not across different processor families. See [http://www.intel.com/products/processor\\_number](http://www.intel.com/products/processor_number) for details.

I<sup>2</sup>C is a two-wire communications bus/protocol developed by Philips. SMBus is a subset of the I<sup>2</sup>C bus/protocol and was developed by Intel. Implementations of the I<sup>2</sup>C bus/protocol may require licenses from various entities, including Philips Electronics N.V. and North American Philips Corporation.

Intel, Xeon, Enhanced Intel SpeedStep Technology, Core, and the Intel logo are trademarks of Intel Corporation in the U. S. and other countries.

\*Other names and brands may be claimed as the property of others.

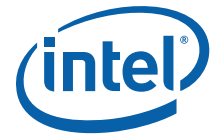
Copyright © 2009-2015, Intel Corporation. All rights reserved.



# Table of Contents

---

<b>1</b>	<b>Overview</b>	7
1.1	Introduction	7
1.3	Terminology	8
1.2	Related Documents	8
1.4	Processor Feature Overview	12
1.4.1	Core Feature Overview	12
1.5	Interface Feature Overview	12
1.5.1	System Memory	12
1.5.2	PCI Express*	13
1.5.3	Direct Media Interface Gen 2 (DMI2)	13
1.5.4	Intel® QuickPath Interconnect (Intel® QPI)	13
1.5.5	Platform Environment Control Interface (PECI)	13
1.6	Package Summary	13
1.7	Statement of Volatility (SOV)	14
1.8	State of Data	14
<b>2</b>	<b>Electrical Specifications</b>	15
2.1	Integrated Voltage Regulators	15
2.2	Processor Signaling	15
2.2.1	System Memory Interface Signals	15
2.2.2	PCI Express* Signals	15
2.2.3	DMI2/PCI Express* Signals	15
2.2.4	Intel® QuickPath Interconnect (Intel® QPI)	15
2.2.5	Platform Environmental Control Interface (PECI)	16
2.2.5.1	Input Device Hysteresis	16
2.2.6	System Reference Clocks (BCLK{0/1}_DP, BCLK{0/1}_DN)	16
2.2.7	JTAG and Test Access Port (TAP) Signals	17
2.2.8	Processor Sideband Signals	17
2.2.9	Power, Ground and Sense Signals	17
2.2.9.1	Power and Ground Lands	17
2.2.9.2	Decoupling Guidelines	17
2.2.9.3	Voltage Identification (VID)	18
2.2.10	Reserved or Unused Signals	18
2.3	Signal Group Summary	19
2.4	Power-On Configuration (POC) Options	22
2.5	Fault Resilient Booting (FRB)	23
2.6	Mixing Processors	24
2.7	Flexible Motherboard Guidelines (FMB)	24
2.8	Absolute Maximum and Minimum Ratings	25
2.8.1	Storage Condition Specifications	25
2.9	DC Specifications	26
2.9.1	Voltage and Current Specifications	26
2.9.2	VCCIN Power Delivery for Integrated Voltage Regulators	27
2.9.3	Die Voltage Validation	29
2.9.3.1	VCCIN Overshoot Specifications	29
2.9.4	Signal DC Specifications	30
2.9.4.1	PCI Express* DC Specifications	34
2.9.4.2	DMI2/PCI Express* DC Specifications	35
2.9.4.3	Intel® QuickPath Interconnect DC Specifications	35
2.9.4.4	Reset and Miscellaneous Signal DC Specifications	35
2.10	System Reference Clock (BCLK{0/1}) Waveforms	35
2.11	Signal Quality	37
2.11.1	DDR3 Signal Quality Specifications	38



2.11.2	I/O Signal Quality Specifications.....	38
2.11.3	Intel® QuickPath Interconnect Signal Quality Specifications .....	38
2.11.4	Input Reference Clock Signal Quality Specifications.....	38
2.11.5	Overshoot/Undershoot Tolerance.....	38
2.11.5.1	Overshoot/Undershoot Magnitude .....	39
2.11.5.2	Overshoot/Undershoot Pulse Duration .....	39
2.11.5.3	Activity Factor .....	39
2.11.5.4	Reading Overshoot/Undershoot Specification Tables .....	40
2.11.5.5	Compliance to Overshoot/Undershoot Specifications .....	40
2.12	C-State Power .....	42
<b>3</b>	<b>Signal Descriptions</b> .....	<b>43</b>
3.1	System Memory Interface Signals.....	43
3.2	PCI Express* Based Interface Signals.....	44
3.3	DMI2/PCI Express* Port 0 Signals .....	45
3.4	Intel® QuickPath Interconnect Signals .....	45
3.5	PECI Signal .....	46
3.6	System Reference Clock Signals .....	46
3.7	JTAG and TAP Signals .....	46
3.8	Serial VID Interface (SVID) Signals.....	46
3.9	Processor Asynchronous Sideband and Miscellaneous Signals .....	47
3.10	Processor Power and Ground Supplies .....	49
<b>4</b>	<b>Processor Land Listing</b> .....	<b>51</b>
4.1	Land Listing by Name .....	51

## Figures

1-1	Two-Socket Processor Platform .....	12
2-1	Input Device Hysteresis .....	16
2-2	VCCIN Static and Transient Tolerance Loadlines .....	29
2-3	VCCIN Overshoot Example Waveform .....	30
2-4	BCLK{0/1} Differential Clock Crosspoint Specification .....	35
2-5	BCLK{0/1} Differential Clock Measurement Points for Duty Cycle and Period .....	36
2-6	BCLK{0/1} Differential Clock Measurement Points for Edge Rate.....	36
2-7	BCLK{0/1} Differential Clock Measurement Point for Ringback .....	36
2-8	BCLK{0/1} Single Ended Clock Measurement Points for Absolute Cross Point and Swing.....	37
2-9	BCLK{0/1} Single Ended Clock Measurement Points for Delta Cross Point .....	37
2-10	Maximum Acceptable Overshoot/Undershoot Waveform.....	41

## Tables

1-1	Processor Datasheet Volume Structure .....	7
1-3	Related Documents and Specifications.....	8
1-2	Processor Documents.....	8
2-1	Power and Ground Lands.....	17
2-2	SVID Address Usage .....	18
2-3	Signal Description Buffer Types .....	19
2-4	Signal Groups .....	19
2-5	Signals with On-Die Termination .....	22
2-6	Power-On Configuration Option Lands .....	22
2-7	Fault Resilient Booting (Output Tri-State) Signals .....	23
2-8	Processor Absolute Minimum and Maximum Ratings.....	25
2-9	Storage Condition Ratings .....	25
2-10	Voltage Specification.....	26
2-11	Processor Power Supply Current Specifications .....	27



2-12	Processor VCCIN Static and Transient Tolerance .....	28
2-13	VCCIN Overshoot Specifications .....	29
2-14	DDR3 and DDR3L Signal DC Specifications.....	30
2-15	PECI DC Specifications .....	31
2-16	System Reference Clock (BCLK{0/1}) DC Specifications .....	32
2-17	SMBus DC Specifications .....	32
2-18	JTAG and TAP Signals DC Specifications .....	33
2-19	Serial VID Interface (SVID) DC Specifications.....	33
2-20	Processor Asynchronous Sideband DC Specifications .....	34
2-21	Miscellaneous Signals DC Specifications.....	34
2-22	Processor I/O Overshoot/Undershoot Specifications .....	38
2-23	Processor Sideband Signal Group Overshoot/Undershoot Tolerance.....	40
2-24	Processor Package C-State Power Specifications .....	42
3-1	Memory Channel DDR1, DDR2, DDR3.....	43
3-2	Memory Channel Miscellaneous .....	44
3-3	PCI Express* Port 1 Signals.....	44
3-4	PCI Express* Port 3 Signals.....	44
3-5	PCI Express* Miscellaneous Signals .....	45
3-6	DMI2 and PCI Express Port 0 Signals .....	45
3-7	Intel® QPI Port Signals.....	45
3-8	PECI Signal .....	46
3-9	System Reference Clock (BCLK) Signals .....	46
3-10	JTAG and TAP Signals .....	46
3-11	SVID Signals .....	46
3-12	Processor Asynchronous Sideband Signals .....	47
3-13	Miscellaneous Signals .....	49
3-14	Power and Ground Signals.....	49
4-1	Land Listing.....	51



## Revision History

---

Revision Number	Description	Revision Date
001	Initial Release	January 2015



# 1 Overview

## 1.1 Introduction

Intel® Xeon® Processor E5-2400 v3 Product Family Datasheet - Volume One provides DC electrical specifications, signal definitions and an overview of processor interfaces.

This document is intended to be distributed as a part of a two volume set. The structure and scope of the volumes is provided in [Table 1-1](#).

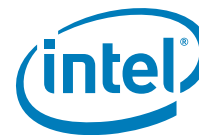
The Intel® Xeon® Processor E5-2400 v3 Product Family is the next generation of 64-bit, multi-core server-class processors built on 22-nanometer process technology. Throughout this document, the Intel® Xeon® Processor E5-2400 v3 Product Family may be referred to as simply the processor. This processor family is based on the low-power, high performance Haswell processor microarchitecture to be paired with a Platform Controller Hub (PCH). The Intel® Xeon® Processor E5-2400 v3 Product Family is targeted for embedded server, communications and storage applications.

This processor features one Intel® QuickPath Interconnect point-to-point link capable of up to 8.0 GT/s, 24 lanes of PCI Express\* 3.0 capable of 8.0 GT/s, and 4 lanes of DMI2/PCI Express\* 2.0 interface with a peak transfer rate of 5.0 GT/s. The processor supports up to 46 bits of physical address space and 48-bit of virtual address space.

This processor family incorporates an integrated memory controller (IMC) and integrated I/O (IIO) including PCI Express\* and DMI2) on a single silicon die.

**Table 1-1. Processor Datasheet Volume Structure**

<b>Volume One: Electrical</b>
• Overview
• Signal Descriptions
• Electrical Specifications
• Processor Land Listing
<b>Volume Two: Registers</b>
• Configuration Process and Registers Overview
• Configuration Space Registers
• Model Specific Registers (MSR)



## 1.2 Related Documents

The following documents provide additional information related to system design with the Intel® Xeon® Processor E5-2400 v3 Product Family.

**Table 1-2. Processor Documents**

Document	Document Number/ Location <sup>1</sup>
<i>Intel® Xeon® Processor E5 v3 Product Families Datasheet Volume 2; Registers</i>	intel.com
<i>Intel® Xeon® Processor E5-2400 v3 Product Families Thermal/Mechanical Specification and Design Guide (TMSDG)</i>	intel.com

**Table 1-3. Related Documents and Specifications**

Document	Document Number/ Location
<i>Advanced Configuration and Power Interface Specification 3.0</i>	<a href="http://www.acpi.info">http://www.acpi.info</a>
<i>PCI Local Bus Specification 3.0</i>	<a href="http://www.pcisig.com/specifications">http://www.pcisig.com/specifications</a>
<i>PCI Express Base Specification - Revision 2.1 and 1.1</i> <i>PCI Express Base Specification - Revision 3.0</i>	<a href="http://www.pcisig.com">http://www.pcisig.com</a>
<i>System Management Bus (SMBus) Specification</i>	<a href="http://smbus.org/">http://smbus.org/</a>
<i>DDR3 SDRAM Specification</i>	<a href="http://www.jedec.org">http://www.jedec.org</a>
<i>Low (JESD22-A119) and High (JESD-A103) Temperature Storage Life Specifications</i>	<a href="http://www.jedec.org">http://www.jedec.org</a>
<i>Intel® 64 and IA-32 Architectures Software Developer's Manuals</i> <ul style="list-style-type: none"> <li>• Volume 1: Basic Architecture</li> <li>• Volume 2A: Instruction Set Reference, A-M</li> <li>• Volume 2B: Instruction Set Reference, N-Z</li> <li>• Volume 3A: System Programming Guide</li> <li>• Volume 3B: System Programming Guide</li> </ul> <i>Intel® 64 and IA-32 Architectures Optimization Reference Manual</i>	<a href="http://www.intel.com/products/processor/manuals/index.htm">http://www.intel.com/products/processor/manuals/index.htm</a>
<i>Intel® Virtualization Technology Specification for Directed I/O Architecture Specification</i>	<a href="http://www.intel.com/content/dam/www/public/us/en/documents/product-specifications/vt-directed-io-spec.pdf">http://www.intel.com/content/dam/www/public/us/en/documents/product-specifications/vt-directed-io-spec.pdf</a>
<i>Intel® Trusted Execution Technology Software Development Guide</i>	<a href="http://www.intel.com/technology/security">www.intel.com/technology/security</a>
<i>National Institute of Standards and Technology NIST SP800-90</i>	<a href="http://csrc.nist.gov/publications/PubsSPs.html">http://csrc.nist.gov/publications/PubsSPs.html</a>

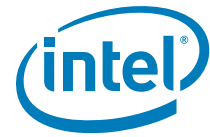
## 1.3 Terminology

Term	Description
ASPM	Active State Power Management
BMC	Baseboard Management Controllers
Cbo	Cache and Core Box. It is a term used for internal logic providing ring interface to LLC and Core.
DDR3	Third generation Double Data Rate SDRAM memory technology that is the successor to DDR2 SDRAM
DMA	Direct Memory Access
DMI	Direct Media Interface
DMI2	Direct Media Interface Gen 2

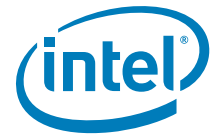




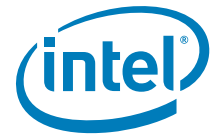
Term	Description
DTS	Digital Thermal Sensor
ECC	Error Correction Code
Enhanced Intel® SpeedStep® Technology	Allows the operating system to reduce power consumption when performance is not needed.
Execute Disable Bit	The Execute Disable bit allows memory to be marked as executable or non-executable, when combined with a supporting operating system. If code attempts to run in non-executable memory the processor raises an error to the operating system. This feature can prevent some classes of viruses or worms that exploit buffer overrun vulnerabilities and can thus help improve the overall security of the system. See the <i>Intel® 64 and IA-32 Architectures Software Developer's Manuals</i> for more detailed information.
FIVR	Fully Integrated the Voltage Regulator. Internal DC-to-DC voltage regulators integrated into processor to provide various voltage levels.
Flit	Flow Control Unit. The Intel® QPI Link layer's unit of transfer; 1 Flit = 80-bits.
Functional Operation	Refers to the normal operating conditions in which all processor specifications, including DC, AC, system bus, signal quality, mechanical, and thermal, are satisfied.
IMC	Integrated Memory Controller. System memory controller that is integrated in the processor die.
IIO	The Integrated I/O Controller. An I/O controller that is integrated in the processor die.
Intel® ME	Intel® Management Engine (Intel® ME)
Intel® QuickData Technology	Intel® QuickData Technology is a platform solution designed to maximize the throughput of server data traffic across a broader range of configurations and server environments to achieve faster, scalable, and more reliable I/O.
Intel® QuickPath Interconnect (Intel® QPI)	A cache-coherent, link-based Interconnect specification for Intel processors, chipsets, and I/O bridge components.
Intel® 64 Technology	64-bit memory extensions to the IA-32 architecture. Further details on Intel® 64 architecture and programming model can be found at <a href="http://developer.intel.com/technology/Intel®64">http://developer.intel.com/technology/Intel®64</a>
Intel® Turbo Boost Technology	Intel® Turbo Boost Technology is a way to automatically run the processor core faster than the marked frequency if the part is operating under power, temperature, and current specifications limits of the Thermal Design Power (TDP). This results in increased performance of both single and multi-threaded applications.
Intel® TXT	Intel® Trusted Execution Technology
Intel® Virtualization Technology (Intel® VT)	Processor virtualization which when used in conjunction with Virtual Machine Monitor software enables multiple, robust independent software environments inside a single platform.
Intel® VT-d	Intel® Virtualization Technology (Intel® VT) for Directed I/O. Intel® VT-d is a hardware assist, under system software (Virtual Machine Manager or OS) control, for enabling I/O device virtualization. Intel® VT-d also brings robust security by providing protection from errant DMAs by using DMA remapping, a key feature of Intel® VT-d.
Integrated Heat Spreader (IHS)	A component of the processor package used to enhance the thermal performance of the package. Component thermal solutions interface with the processor at the IHS surface.
Jitter	Any timing variation of a transition edge or edges from the defined Unit Interval (UI).
IOV	I/O Virtualization
LGA1356 Socket	The 1356-land FCLGA package mates with the system board through this surface mount, 1356-contact socket.
LLC	Last Level Cache
LRDIMM	Load Reduced Dual In-line Memory Module
NCTF	Non-Critical to Function: NCTF locations are typically redundant ground or non-critical reserved, so the loss of the solder joint continuity at end of life conditions will not affect the overall product functionality.



Term	Description
NEBS	Network Equipment Building System. NEBS is the most common set of environmental design guidelines applied to telecommunications equipment in the United States.
PCH	Platform Controller Hub. The next generation chipset with centralized platform capabilities including the main I/O interfaces along with display connectivity, audio features, power management, manageability, security and storage features.
PCU	Power Control Unit
PCI Express* 3.0	PCI Express* Generation 3.0 The third generation PCI Express* specification that operates at twice the speed of PCI Express* 2.0 (8 Gb/s). PCI Express* 3.0 is backward compatible with PCI Express* 1.0 and 2.0.
PCI Express* 2.0	PCI Express* Generation 2.0
PCI Express*	PCI Express* Generation 2.0/3.0
PECI	Platform Environment Control Interface
Phit	Physical Unit. Intel® QPI terminology defining units of transfer at the physical layer. 1 Phit is equal to 20 bits in 'full width mode' and 10 bits in 'half width mode'
Processor	The 64-bit, single-core or multi-core component (package)
Core	A functional element of the processor capable of executing instructions. Each core has an instruction cache, data cache, and 256-KB L2 cache. All execution cores share the L3 cache.
RDIMM	Registered Dual In-line Module
Rank	A unit of DRAM corresponding four to eight devices in parallel, ignoring ECC. These devices are usually, but not always, mounted on a single side of a DDR3 DIMM.
SCI	System Control Interrupt. Used in ACPI protocol.
SSE	Intel® Streaming SIMD Extensions (Intel® SSE)
SKU	Stock Keeping Unit (SKU) identifying a particular model having unique attributes. Electrical, power and thermal specifications for these SKU's are based on specific use condition assumptions.
SMBus	System Management Bus. A two-wire interface through which simple system and power management related devices can communicate with the rest of the system. It is based on the principals of the operation of the I2C* two-wire serial bus from Philips Semiconductor.
Storage Conditions	A non-operational state. The processor may be installed in a platform, in a tray, or loose. Processors may be sealed in packaging or exposed to open air. Under these conditions, processor land contacts should not be connected to any supply voltages, have any I/O buffers biased or receive any clocks. Upon exposure to "free air" (i.e., unsealed packaging or a device removed from packaging material) the processor must be handled in accordance with moisture sensitivity labeling (MSL) as indicated on the packaging material.
TAC	Thermal Averaging Constant
TDP	Thermal Design Power
TSOD	Thermal Sensor on DIMM
UDIMM	Unbuffered Dual In-line Module
Uncore	The portion of the processor comprised of the shared cache, IMC, HA, PCU, UBox, and Intel® QPI link interface.
Unit Interval	Signaling convention that is binary and unidirectional. In this binary signaling, one bit is sent for every edge of the forwarded clock, whether it be a rising edge or a falling edge. If a number of edges are collected at instances $t_1, t_2, t_n, \dots, t_k$ then the UI at instance "n" is defined as: $UI_n = t_n - t_{n-1}$
V <sub>CCIN</sub>	Voltage rail supplies the input source to the integrated voltage regulators.
V <sub>SS</sub>	Processor ground



Term	Description
V <sub>CCD</sub>	DDR3 power supply for the processor system memory interface.
x1	Refers to a Link or Port with one Physical Lane
x4	Refers to a Link or Port with four Physical Lanes
x8	Refers to a Link or Port with eight Physical Lanes
x16	Refers to a Link or Port with sixteen Physical Lanes



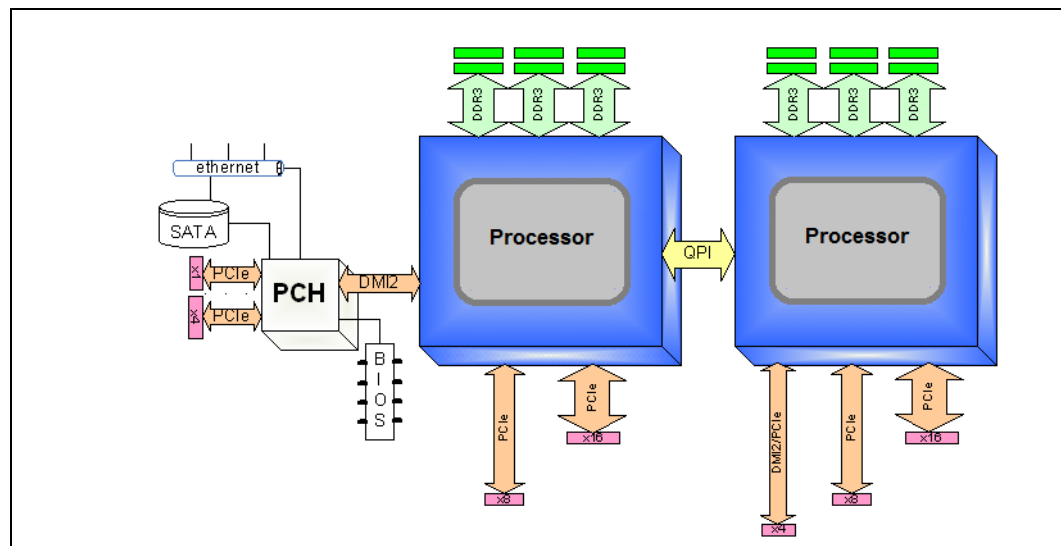
## 1.4 Processor Feature Overview

### 1.4.1 Core Feature Overview

- Up to 10 physical cores
- Each core supports two threads (Intel® Hyper-Threading Technology), up to 20 threads per socket
- 32-KB instruction and 32-KB data first-level cache (L1) for each core
- 256-KB shared instruction/data mid-level (L2) cache for each core
- Up to 25 MB last level cache (LLC): up to 2.5 MB per core instruction/data last level cache (LLC), shared among all cores

A rudimentary block diagram is illustrated in [Figure](#) with two processors interconnected to a Platform Controller Hub (PCH).

**Figure 1-1. Two-Socket Processor Platform**



## 1.5 Interface Feature Overview

This section presents a limited high-level overview of the physical interfaces of the Intel® Xeon® Processor E5-2400 v3 Product Family.

### 1.5.1 System Memory

- Three DDR3 channels
- DDR3 standard I/O Voltage of 1.5 V and DDR3 Low Voltage of 1.35 V
- 64-bit wide data plus 8-bits of ECC support for each channel
- Data transfer rates of 800, 1066, 1333, and 1600 MT/s
- Unbuffered DDR3 and registered DDR3 DIMMs
- 1Gb, 2Gb and 4Gb DDR3 DRAM technologies are supported for these devices:
  - UDIMMs x8, x16
  - RDIMMs x4, x8



- Up to 8 ranks supported per memory channel, 1, 2 or 4 ranks per DIMM
- Memory thermal monitoring support for DIMM temperature via two memory signals, MEM\_HOT\_C{01/23}\_N

### 1.5.2 PCI Express\*

- Up to 24 lanes of PCI Express\*
- Compliant to the *PCI Express\* Base Specification, Revision 3.0 (PCIe\* 3.0)*
- Configurable for up to six independent ports
- 4 lanes of PCI Express\* at PCIe\* 2.0 speeds when not using DMI2 port (Port 0), also can be downgraded to x2 or x1
- Reduced link width negotiation supported:
  - x16 port (Port 3) may negotiate down to x8, x4, x2, or x1
  - x8 port (Port 1) may negotiate down to x4, x2, or x1
  - x4 port (Port 0) may negotiate down to x2, or x1
  - Lane reversal supported with limitations on reduced widths
- Non-Transparent Bridge (NTB) is supported by PCIe Port3a/IOU1. For more details on NTB mode operation refer to *PCI Express Base Specification - Revision 3.0*.

### 1.5.3 Direct Media Interface Gen 2 (DMI2)

- Primary processor interface to the platform controller hub (PCH)
- Link width is exclusively x4 in DMI2 mode
- Operation at PCI Express\* 1.0 or 2.0 speeds

### 1.5.4 Intel® QuickPath Interconnect (Intel® QPI)

- One Intel® QuickPath Interconnect port
- Full width port with 20 data lanes and 1 clock lane
- No bifurcation support
- Differential signaling
- Forwarded clocking with common input reference clock
- Up to 8.0 GT/s data rate (up to 16 GB/s direction peak bandwidth)

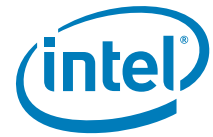
### 1.5.5 Platform Environment Control Interface (PECI)

PECI is a single-wire multi-drop interface providing a comm

- Supports operation at up to 2 Mbps data transfers

## 1.6 Package Summary

The Processor socket type is noted as Socket B3. It is a 45 mm x 42.5 mm FCLGA12 package (LGA1356-3).



## 1.7 Statement of Volatility (SOV)

The Intel® Xeon® Processor E5-2400 v3 Product Family does not retain any end-user data when powered down and/or the processor is physically removed from the socket.

## 1.8 State of Data

The data contained within this document is the most accurate information available by the publication date of this document. Electrical DC specifications are based on estimated I/O buffer behavior.

§



## 2 Electrical Specifications

---

### 2.1 Integrated Voltage Regulators

The Intel® Xeon® Processor E5-2400 v3 Product Family introduces platform innovation by integrating several voltage regulators into the processor. Integrating these voltage regulators reduces cost and simplifies system design by reducing the number of external regulators on the system board.

The  $V_{CCIN}$  voltage rail supplies the input source to the integrated voltage regulators powering cores, cache and system agents. This integration improves regulation of on-die voltages optimizing performance and power savings. The  $V_{CCIN}$  rail is supplied by an external voltage regulator.

### 2.2 Processor Signaling

The processor includes 1356 lands, which utilize various signaling technologies. Signals are grouped by electrical characteristics and buffer type into various signal groups. These include DDR3 (Reference Clock, Command, Control, and Data), PCI Express\*, DMI2, Intel® QuickPath Interconnect, Platform Environmental Control Interface (PECI), System Reference Clock, SMBus, JTAG and Test Access Port (TAP), SVID Interface, Processor Asynchronous Sideband, Miscellaneous, and Power/Other signals. Refer to [Table 2-4](#) for details.

Intel strongly recommends performing analog simulations of all interfaces. Refer to [Section 1.2, "Related Documents"](#) for signal integrity model availability.

#### 2.2.1 System Memory Interface Signals

The system memory interface utilizes DDR3 technology, consisting of numerous signal groups. These include: Reference Clocks, Command Signals, Control Signals, and Data Signals. Each group consists of numerous signals, which may utilize various signaling technologies. Refer to [Table 2-4](#) for further details. Throughout this chapter the system memory interface maybe referred to as DDR3.

#### 2.2.2 PCI Express\* Signals

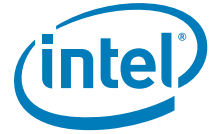
The PCI Express Signal Group consists of PCI Express\* ports 1, 2, and 3, and PCI Express\* miscellaneous signals. Refer to [Table 2-4](#) for further details.

#### 2.2.3 DMI2/PCI Express\* Signals

The Direct Media Interface Gen 2 (DMI2) sends and receives packets and/or commands to the PCH. DMI2 is an extension of the standard PCI Express Specification. The DMI2/PCI Express interface consist of DMI2 receive and transmit input/output signals. Refer to [Table 2-4](#) for further details.

#### 2.2.4 Intel® QuickPath Interconnect (Intel® QPI)

The processor provides one Intel® QPI port for high speed serial transfer between processors. The port consists of two uni-directional links (for transmit and receive). A high-speed differential signaling scheme is utilized.



## 2.2.5 Platform Environmental Control Interface (PECI)

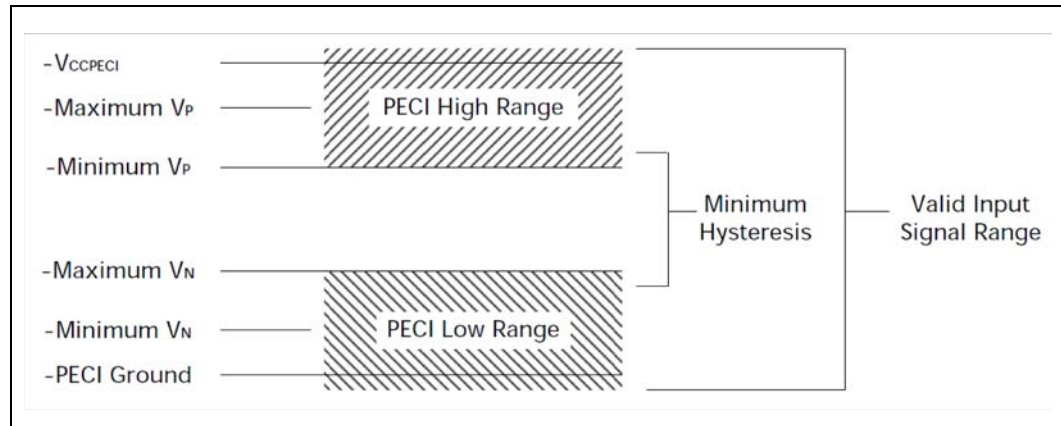
PECI is an Intel® proprietary interface that provides a communication channel between Intel® processors and chipset components to external system management logic and thermal monitoring devices. The processor integrates a Digital Thermal Sensor (DTS) that reports a relative die temperature as an offset from Thermal Control Circuit (TCC) activation temperature. Temperature sensors located throughout the die are implemented as analog-to-digital converters calibrated at the factory. PEFI provides an interface for external devices to read processor temperature, perform processor manageability functions, and manage processor interface tuning and diagnostics.

The PEFI interface operates at a nominal voltage set by  $V_{CCPECI}$ . The DC electrical specifications shown in Table 2-15.

### 2.2.5.1 Input Device Hysteresis

The PEFI client and host input buffers must use a Schmitt-triggered input design for improved noise immunity. Refer to Figure 2-1 and Table 2-15.

Figure 2-1. Input Device Hysteresis



## 2.2.6 System Reference Clocks (BCLK{0/1}\_DP, BCLK{0/1}\_DN)

The processor core, processor uncore, Intel® QuickPath Interconnect link, PCI Express\* and DDR3 memory interface frequencies are generated from BCLK{0/1}\_DP and BCLK{0/1}\_DN signals. There is no relationship between core frequency and Intel® QuickPath Interconnect link frequency. The processor maximum core frequency, Intel® QuickPath Interconnect link frequency and DDR memory frequency are set during manufacturing. It is possible to override the processor core frequency setting using BIOS configuration software. This permits operation at frequencies lower than the factory set maximum frequencies.

The processor core frequency is configured during reset by using values stored within the device during manufacturing.

Clock multiplying within the processor is provided by the internal phase locked loop (PLL), which requires a constant frequency BCLK{0/1}\_DP, BCLK{0/1}\_DN input, with exceptions for spread spectrum clocking. DC specifications for the BCLK{0/1}\_DP, BCLK{0/1}\_DN inputs are provided in Table 2-16.





### 2.2.7 JTAG and Test Access Port (TAP) Signals

Due to the voltage levels supported by other components in the JTAG and Test Access Port (TAP) logic, Intel recommends the processor be first in the TAP chain, followed by any other components within the system. A translation buffer should be used to connect to the rest of the chain unless one of the other components is capable of accepting an input of the appropriate voltage. Two copies of each signal may be required with each driving a different voltage level.

### 2.2.8 Processor Sideband Signals

The processor include asynchronous sideband signals that provide asynchronous input, output or I/O signals between the processor and the platform or Platform Controller Hub. Details can be found in [Table 2-4](#) and the platform design guide.

All Processor Asynchronous Sideband input signals are required to be asserted/deasserted for a defined number of BCLKs in order for the processor to recognize the proper signal state.

### 2.2.9 Power, Ground and Sense Signals

Processors also include power and ground inputs and voltage sense points. Details can be found in [Table 2-4](#) and the *Platform Design Guide*.

#### 2.2.9.1 Power and Ground Lands

All  $V_{CCIN}$ ,  $V_{CCD}$ ,  $V_{CCIO\_IN}$  and  $V_{CCPECI}$  lands must be connected to their respective processor power planes, while all  $V_{SS}$  lands must be connected to the system ground plane. Refer to the platform design guide for decoupling, voltage plane and routing guidelines for each power supply voltage.

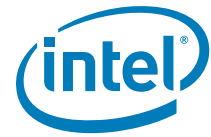
For clean on-chip power distribution, processors include lands for all required voltage supplies. These are listed in [Table 2-1](#).

**Table 2-1. Power and Ground Lands**

Power and Ground Lands	Number of Lands	Comments
$V_{CCIN}$	107	Each $V_{CCIN}$ land must be connected to the voltage supply providing input to the integrated voltage regulators. The operating voltage is requested via by the SVID interface.
$V_{CCD}$	16	Each $V_{CCD}$ land is connected to a switchable supply that provides power to the processor DDR3 interface. This supply also powers the DDR3 memory subsystem. $V_{CCD}$ is also controlled by the SVID Bus
$V_{CCIO\_IN}$	1	Connected to Miscellaneous I/O voltage supply.
$V_{CCPECI}$	1	Connected to Miscellaneous I/O voltage supply.
$V_{SS}$	417	Ground

#### 2.2.9.2 Decoupling Guidelines

Due to its large number of transistors and high internal clock speeds, the processor is capable of generating large current swings between low and full power states. This may cause voltages on power planes to sag below their minimum values if bulk decoupling is not adequate. Large electrolytic bulk capacitors ( $C_{BULK}$ ), help maintain the output voltage during current transients, for example coming out of an idle condition. Care



must be taken in the baseboard design to ensure that the voltages provided to the processor remain within the specifications listed in [Table 2-10](#). Failure to do so can result in timing violations or reduced operational lifetime of the processor. For requirements and implementation details, refer to the *Platform Design Guide*.

### 2.2.9.3 Voltage Identification (VID)

The target voltage level or the VID setting is transmitted via the SVID bus from the processor to the voltage regulator controller chip. The VID settings are the nominal voltages to be delivered to the processor's lands. VID codes will vary as a function of temperature and current load changes in order to minimize power and maximize performance of the processor. The processor specifies the VID required from the voltage regulator to operate at desired frequencies.

Individual processor VID values may be calibrated during manufacturing such that two processor units with the same core frequency may have different default VID settings.

If the processor socket is empty (SKTOCC\_N high), or a “not supported” response is received from the SVID bus, then the voltage regulation circuit cannot supply the voltage that is requested, the voltage regulator must disable itself or not power on. Vout MAX register (30h) is programmed by the processor to set the maximum supported VID code and if the programmed VID code is higher than the VID supported by the VR, then VR will respond with a “not supported” acknowledgement.

#### 2.2.9.3.1 SVID Voltage Regulator Addressing

The processor addresses two voltage rail control segments ( $V_{CCIN}$  and  $V_{CCD}$ ). The SVID data packet contains a 4-bit address encoding as shown in [Table 2-2](#)

**Table 2-2. SVID Address Usage**

PWM Address (HEX)	Processor Supply
00	$V_{CCIN}$
01	NA
02	$V_{CCD}$
03	N/A

**Notes:**

1. Consult VR vendor for determining the physical address assignment method for their controllers.
2. VR addressing is assigned on a per voltage rail basis.
3. Dual VR controllers have two addresses with the lowest order address, always being the higher phase count.
4. For future platform flexibility, the VR controller should include an address offset, as shown with +1 not used.

### 2.2.10 Reserved or Unused Signals

All Reserved (RSVD) signals must not be connected. Connection of these signals to  $V_{CCIN}$ ,  $V_{CCD}$ ,  $V_{CCIO\_IN}$ ,  $V_{CCPECL}$ ,  $V_{SS}$ , or to any other signal (including each other) can result in component malfunction or incompatibility with future processors.

For reliable operation, always connect unused inputs or bi-directional signals to an appropriate signal level. Unused active high inputs should be connected through a resistor to ground ( $V_{SS}$ ). Unused outputs maybe left unconnected; however, this may interfere with some Test Access Port (TAP) functions, complicate debug probing, and prevent boundary scan testing. A resistor must be used when tying bi-directional signals to power or ground. When tying any signal to power or ground, a resistor will



also allow for system testability. Resistor values should be within  $\pm 20\%$  of the impedance of the baseboard trace, unless otherwise noted in the appropriate platform design guidelines.

## 2.3 Signal Group Summary

Signals are grouped by buffer type and similar characteristics as listed in [Table 2-3](#). The buffer type indicates which signaling technology and specifications apply to the signals.

**Table 2-3. Signal Description Buffer Types**

Buffer Type	Description
Analog	Analog reference or output. May be used as a threshold voltage or for buffer compensation
Asynchronous <sup>1</sup>	Signal has no timing relationship with any system reference clock.
CMOS	CMOS buffers: 1.05V
DDR3	DDR3 buffers: 1.5V and 1.35V
DMI2	Direct Media Interface Gen 2 signals compatible with PCI Express* 2.0 and 1.0 Signalling Environment AC Specifications.
Intel® QPI	Current-mode 6.4 GT/s and 8.0 GT/s forwarded-clock Intel® QuickPath Interconnect signaling
Open Drain CMOS	Open Drain CMOS (ODCMOS) buffers: 1.05V tolerant
PCI Express*	PCI Express* interface signals. These signals are compatible with PCI Express 3.0 Signalling Environment AC Specifications and are AC coupled. The buffers are not 3.3-V tolerant. Refer to the PCIe specification.
Reference	Voltage reference signal.
SSTL	Source Series Terminated Logic (JEDEC SSTL_15)

**Notes:**

1. Qualifier for buffer type.

**Table 2-4. Signal Groups (Sheet 1 of 3)**

Differential/Single Ended	Buffer Type	Signals <sup>1</sup>
<b>DDR3 Reference Clocks<sup>2</sup></b>		
Differential	SSTL Output	DDR{1/2/3}_CLK_D[N/P][3:0]
<b>DDR3 Command Signals<sup>2</sup></b>		
Single ended	SSTL Output	DDR{1/2/3}_BA[2:0] DDR{1/2/3}_CAS_N DDR{1/2/3}_MA[15:0] DDR{1/2/3}_PAR DDR{1/2/3}_RAS_N DDR{1/2/3}_WE_N
<b>DDR3 Control Signals<sup>2</sup></b>		
Single ended	CMOS1.5v Output	DDR{1/2/3}_CS_N[7:0] DDR{1/2/3}_ODT[3:0] DDR{1/2/3}_CKE[3:0]
	Reference Output	DDR01_VREFDQ[1], DDR23_VREFDQ[1:0]
	Reference Input	DDR01_VREF, DDR23_VREF
	Compensation Input	DDR{01/23}_RCOMP[2:0]
<b>DDR3 Data Signals<sup>2</sup></b>		



**Table 2-4. Signal Groups (Sheet 2 of 3)**

Differential/Single Ended	Buffer Type	Signals <sup>1</sup>
Differential	SSTL Input/Output	DDR{1/2/3}_DQS_[N/P][17:0]
Single ended	SSTL Input/Output	DDR{1/2/3}_DQ[63:0] DDR{1/2/3}_ECC[7:0]
	SSTL Input	DDR{1/2/3}_PAR_ERR_N
<b>DDR3 Miscellaneous Signals<sup>2</sup></b>		
Single ended	CMOS Input Note: Input voltage from cannot exceed 1.08V max.	DRAM_PWR_OK_C{01/23}
	CMOS1.5v Output	DDR_RESET_C{1/23}_N
<b>PCI Express* Port 1 &amp; 3 Signals</b>		
Differential	PCI Express* Input	PE1A_RX_D[N/P][3:0] PE1B_RX_D[N/P][7:4] PE3A_RX_D[N/P][3:0] PE3B_RX_D[N/P][7:4] PE3C_RX_D[N/P][11:8] PE3D_RX_D[N/P][15:12]
Differential	PCI Express* Output	PE1A_TX_D[N/P][3:0] PE1B_TX_D[N/P][7:4] PE3A_TX_D[N/P][3:0] PE3B_TX_D[N/P][7:4] PE3C_TX_D[N/P][11:8] PE3D_TX_D[N/P][15:12]
<b>DMI2/PCI Express* Signals</b>		
Differential	DMI2 Input	DMI_RX_D[N/P][3:0]
	DMI2 Output	DMI_TX_D[N/P][3:0]
<b>Intel® QuickPath Interconnect (Intel® QPI) Signals</b>		
Differential	Intel® QPI Input	QPI1_DRX_D[N/P][19:0] QPI1_CLKRX_D[N/P]
	Intel® QPI Output	QPI1_DTX_D[N/P][19:0] QPI1_CLKTX_D[N/P]
<b>Platform Environmental Control Interface (PECI)</b>		
Single ended	PECI	PECI
<b>System Reference Clock (BCLK{0/1})</b>		
Differential	CMOS1.05v Input	BCLK{0/1}_D[N/P]
<b>SMBus</b>		
Single ended	Open Drain CMOS Input/Output	DDR_SCL_C{01/23} DDR_SDA_C{01/23} PE_HP_SCL PE_HP_SDA



**Table 2-4. Signal Groups (Sheet 3 of 3)**

Differential/Single Ended	Buffer Type	Signals <sup>1</sup>
<b>JTAG &amp; TAP Signals</b>		
Single ended	CMOS1.05v Input	TCK, TDI, TMS, TRST_N, EAR_N
	CMOS1.05v Input/Output	PREQ_N
	CMOS1.05v Output	PRDY_N
	Open Drain CMOS Input/Output	BPM_N[7:0]
	Open Drain CMOS Output	TDO
<b>Serial VID Interface (SVID) Signals</b>		
Single ended	CMOS1.05v Input	SVIDALERT_N
	Open Drain CMOS Input/Output	SVIDDATA
	Open Drain CMOS Output	SVIDCLK
<b>Processor Asynchronous Sideband Signals</b>		
Single ended	CMOS1.05v Input	BIST_ENABLE BMCINIT DEBUG_EN_N FRMAGENT PWRGOOD PMSYNC RESET_N SAFE_MODE_BOOT SOCKET_ID[1:0] TXT_AGENT TXT_PLTEN
		CMOS1.05v Output
	Open Drain CMOS Input/Output	CATERR_N MEM_HOT_C{01/23}_N MSMI_N PM_FAST_WAKE_N PROCHOT_N
		Open Drain CMOS Output
<b>Miscellaneous Signals</b>		
N/A	Output	PROC_ID_N <sup>2</sup> SKTOCC_N
<b>Power/Other Signals</b>		
	Power / Ground	V <sub>CCIN</sub> , V <sub>CCD</sub> , V <sub>CCIO_IN</sub> , V <sub>CCPECL</sub> , V <sub>SS</sub>
	Sense Points	V <sub>CCIN_SENSE</sub> V <sub>SS_VCCIN_SENSE</sub>

**Notes:**

1. DDR{1/2/3} refers toDDR3 Channel 1, DDR3 Channel 2 and DDR3 Channel 3.
2. PROC\_ID\_N land is unconnected within the processor package.

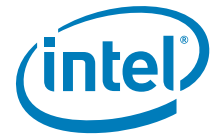


Table 2-5. Signals with On-Die Termination

Signal Name	Pull Up /Pull Down	Rail	Value	Units	Notes
BIST_ENABLE	Pull Up	V <sub>CCIO_IN</sub>	5K-15K	Ω	1
BMCINIT	Pull Down	VSS	5K-15K	Ω	1
DDR{1/2/3}_PAR_ERR_N	Pull Up	VCCD	100	Ω	1
DEBUG_EN_N	Pull Up	V <sub>CCIO_IN</sub>	5K-15K	Ω	1
EAR_N	Pull Up	V <sub>CCIO_IN</sub>	5K-15K	Ω	1
FRMAGENT	Pull Down	VSS	5K-15K	Ω	1
PM_FAST_WAKE_N	Pull Up	V <sub>CCIO_IN</sub>	5K-15K	Ω	1
SAFE_MODE_BOOT	Pull Down	VSS	5K-15K	Ω	1
SOCKET_ID[1:0]	Pull Down	VSS	5K-15K	Ω	1
TCK	Pull Down	VSS	5K-15K	Ω	1
TDI	Pull Up	V <sub>CCIO_IN</sub>	5K-15K	Ω	1
TMS	Pull Up	V <sub>CCIO_IN</sub>	5K-15K	Ω	1
TRST_N	Pull Up	V <sub>CCIO_IN</sub>	5K-15K	Ω	1
TXT_AGENT	Pull Down	VSS	5K-15K	Ω	1
TXT_PLTEN	Pull Up	V <sub>CCIO_IN</sub>	5K-15K	Ω	1

**Notes:**

1. Refer to the *Platform Design Guide* for circuit implementations for these signals.

## 2.4 Power-On Configuration (POC) Options

Functional options can be configured by hardware strapping of input signals. The processor samples its hardware configuration at reset, on the active-to-inactive transition of RESET\_N, or upon assertion of PWRGOOD (inactive-to-active transition). Configuration options are described in [Table 2-6](#).

The sampled input configures the processor for subsequent operation. These configuration options cannot be changed except by another reset transition of the latching signal (RESET\_N or PWRGOOD).

Table 2-6. Power-On Configuration Option Lands

Configuration Option	Land Name	Notes
Output high impedance state (FRB mode)	PROCHOT_N	1
Execute BIST (Built-In Self Test)	BIST_ENABLE	2
Enable Service Processor Boot Mode	BMCINIT	3
Enable Intel® Trusted Execution Technology (Intel® TXT) Platform	TXT_PLTEN	3
Power-up Sequence Halt	EAR_N	3
Enable Bootable Firmware Agent	FRMAGENT	3
Enable Intel® Trusted Execution Technology (Intel® TXT) Agent	TXT_AGENT	3
Enable Safe Mode Boot	SAFE_MODE_BOOT	3
Configure Socket ID	SOCKET_ID[1:0]	3

**Notes:**

1. PROCHOT\_N for FRB mode is latched at de-assertion of RESET\_N. Output high-impedance option enables Fault Resilient Booting (FRB) as detailed in [Section 2.5](#).
2. BIST\_ENABLE is sampled at de-assertion of RESET\_N.



- Signal is sampled at assertion of PWRGOOD .

## 2.5 Fault Resilient Booting (FRB)

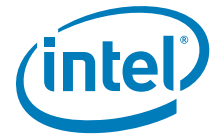
The processor supports both socket and core level Fault Resilient Booting (FRB), which provides the ability to boot the system as long as there is one processor functional in the system. One limitation to socket level FRB is that the system cannot boot if the legacy socket that connects to an active PCH becomes unavailable since this is the path to the system BIOS. See [Table 2-7](#) for a list of output tri-state FRB signals.

Socket level FRB will tri-state processor outputs via the PROCHOT\_N signal. Assertion of the PROCHOT\_N signal through RESET\_N de-assertion will tri-state processor outputs. Note, that individual core disabling is also supported for those cases where disabling the entire package is not desired.

The processor extends the FRB capability to the core granularity by maintaining a register in the uncore so that BIOS or another entity can disable one or more specific processor cores.

**Table 2-7. Fault Resilient Booting (Output Tri-State) Signals (Sheet 1 of 2)**

Output Tri-State Signal Groups	Signals
Intel® QPI	QPI0_CLKTX_DN[1:0] QPI0_CLKTX_DP[1:0] QPI0_DTX_DN[19:0] QPI0_DTX_DP[19:0] QPI1_CLKTX_DN[1:0] QPI1_CLKTX_DP[1:0] QPI1_DTX_DN[19:0] QPI1_DTX_DP[19:0]
PCI Express*	PE1A_TX_DN[3:0] PE1A_TX_DP[3:0] PE1B_TX_DN[7:4] PE1B_TX_DP[7:4] PE2A_TX_DN[3:0] PE2A_TX_DP[3:0] PE2B_TX_DN[7:4] PE2B_TX_DP[7:4] PE2C_TX_DN[11:8] PE2C_TX_DP[11:8] PE2D_TX_DN[15:12] PE2D_TX_DP[15:12] PE3A_TX_DN[3:0] PE3A_TX_DP[3:0] PE3B_TX_DN[7:4] PE3B_TX_DP[7:4] PE3C_TX_DN[11:8] PE3C_TX_DP[11:8] PE3D_TX_DN[15:12] PE3D_TX_DP[15:12] PE_HP_SCL PE_HP_SDA
DMI2	DMI_TX_DN[3:0], DMI_TX_DP[3:0]



**Table 2-7. Fault Resilient Booting (Output Tri-State) Signals (Sheet 2 of 2)**

Output Tri-State Signal Groups	Signals
<b>SMBus</b>	DDR_SCL_C01 DDR_SDA_C01 DDR_SCL_C23 DDR_SDA_C23 PE_HP_SCL PE_HP_SDA
<b>Processor Sideband</b>	BPM_N[7:0] CATERR_N ERROR_N[2:0] FIVR_FAULT MEM_HOT_C01_N MEM_HOT_C23_N MSMI_N PM_FAST_WAKE_N PROCHOT_N PECI PM_FASTWAKE_N PRDY_N THERMTRIP_N
<b>SVID</b>	SVIDCLK SVIDDATA

## 2.6 Mixing Processors

Intel® supports and validates two-processor configurations only in which all processors operate with the same Intel® QuickPath Interconnect frequency, core frequency, power segment having the same internal cache sizes. Mixing components operating at different internal clock frequencies is not supported and will not be validated by Intel®. Combining processors from different power segments is also not supported.

**Note:** Processors within a system must operate at the same frequency per bits [15:8] of the FLEX\_RATIO MSR (Address: 194h); however this does not apply to frequency transitions initiated due to thermal events, Extended HALT, Enhanced Intel® SpeedStep Technology transitions signal.

Not all operating systems can support dual processors with mixed frequencies. Mixing processors of different steppings but the same model (as per CPUID instruction) is supported provided there is no more than one stepping delta between the processors, for example, S and S+1.

S and S+1 is defined as mixing of two CPU steppings in the same platform where one CPU is S (stepping) = CPUID.(EAX=01h):EAX[3:0], and the other is S+1 = CPUID.(EAX=01h):EAX[3:0]+1. The stepping ID is found in EAX[3:0] after executing the CPUID instruction with Function 01h. Details regarding the CPUID instruction are provided in *Intel® 64 and IA-32 Architectures Software Developer's Manual (SDM) Volumes 1, 2, and 3*.

## 2.7 Flexible Motherboard Guidelines (FMB)

Flexible Motherboard (FMB) guidelines are estimates of the maximum values the processor will have over certain time periods. The values are only estimates and actual specifications for future processors may differ. Processors may or may not have





specifications equal to the FMB value in the foreseeable future. System designers should meet the FMB values to ensure their systems will be compatible with future processors.

## 2.8 Absolute Maximum and Minimum Ratings

Table 2-8 specifies absolute maximum and minimum ratings. At conditions outside functional operation condition limits, but within absolute maximum and minimum ratings, neither functionality nor long-term reliability can be expected. If a device is returned to conditions within functional operation limits after having been subjected to conditions outside these limits, but within the absolute maximum and minimum ratings, the device may be functional, but with its lifetime degraded depending on exposure to conditions exceeding the functional operation condition limits.

Although the processor contains protective circuitry to resist damage from Electro-Static Discharge (ESD), precautions should always be taken to avoid high static voltages or electric fields.

**Table 2-8. Processor Absolute Minimum and Maximum Ratings**

Symbol	Parameter	Min	Max	Unit
V <sub>CCIN</sub>	Integrated Voltage Regulator voltage with respect to V <sub>SS</sub>	-0.3	1.98	V
V <sub>CCD</sub>	Processor I/O supply voltage for DDR3 (standard voltage) with respect to V <sub>SS</sub>	-0.3	1.85	V
V <sub>CCDL</sub>	Processor I/O supply voltage for DDR3L (Low Voltage) with respect to V <sub>SS</sub>	-0.3	1.7	V
V <sub>CCIO_IN</sub>	Processor I/O voltage with respect to V <sub>SS</sub>	-0.3	1.4	V
V <sub>CCPECI</sub>	Processor PECL voltage with respect to V <sub>SS</sub>	-0.3	1.4	V

**Notes:**

1. For functional operation, all processor electrical, signal quality, mechanical, and thermal specifications must be satisfied.
2. Overshoot and undershoot voltage guidelines for input, output, and I/O signals are outlined. Excessive overshoot or undershoot on any signal will likely result in permanent damage to the processor.

### 2.8.1 Storage Condition Specifications

Environmental storage condition limits define the temperature and relative humidity limits to which the device is exposed to while being stored in a Moisture Barrier Bag. The specified storage conditions are for component level prior to board attach (see notes in Table 2-9 for post board attach limits).

Table 2-9 specifies absolute maximum and minimum storage temperature limits which represent the maximum or minimum device condition beyond which damage, latent or otherwise, may occur. The table also specifies sustained storage temperature, relative humidity, and time-duration limits. These limits specify the maximum or minimum device storage conditions for a sustained period of time. At conditions outside sustained limits, but within absolute maximum and minimum ratings, quality & reliability may be affected.

**Table 2-9. Storage Condition Ratings (Sheet 1 of 2)**

Symbol	Parameter	Min	Max	Unit
T <sub>absolute storage</sub>	The minimum/maximum device storage temperature beyond which damage (latent or otherwise) may occur when subjected to for any length of time.	-25	125	°C

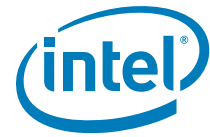


Table 2-9. Storage Condition Ratings (Sheet 2 of 2)

Symbol	Parameter	Min	Max	Unit
$T_{\text{sustained storage}}$	The minimum/maximum device storage temperature for a sustained period of time.	-5	40	°C
$T_{\text{short term storage}}$	The ambient storage temperature (in shipping media) for a short period of time.	-20	85	°C
$RH_{\text{sustained storage}}$	The maximum device storage relative humidity for a sustained period of time.	60% @ 24		°C
$Time_{\text{sustained storage}}$	A prolonged or extended period of time; typically associated with sustained storage conditions Unopened bag, includes 6 months storage time by customer.	0	30	months
$Time_{\text{short term storage}}$	A short period of time (in shipping media).	0	72	hours

**Notes:**

- Storage conditions are applicable to storage environments only. In this scenario, the processor must not receive a clock, and no lands can be connected to a voltage bias. Storage within these limits will not affect the long-term reliability of the device. For functional operation, refer to the processor case temperature specifications.
- These ratings apply to the Intel® component and do not include the tray or packaging.
- Failure to adhere to this specification can affect the long-term reliability of the processor.
- Non-operating storage limits post board attach: Storage condition limits for the component once attached to the application board are not specified. Intel® does not conduct component level certification assessments post board attach given the multitude of attach methods, socket types and board types used by customers. Provided as general guidance only, Intel® board products are specified and certified to meet the following temperature and humidity limits (Non-Operating Temperature Limit: -40C to 70C & Humidity: 50% to 90%, non condensing with a maximum wet bulb of 28C).
- Device storage temperature qualification methods follow JEDEC High and Low Temperature Storage Life Standards: *JESD22-A119* (low temperature) and *JESD22-A103* (high temperature).

## 2.9 DC Specifications

**DC specifications are defined at the processor pads, unless otherwise noted.**

DC specifications are only valid while meeting specifications for case temperature, clock frequency, and input voltages. Care should be taken to read all notes associated with each specification.

### 2.9.1 Voltage and Current Specifications

Table 2-10. Voltage Specification

Symbol	Parameter	Voltage Plane	Min	Nom	Max	Unit	Notes <sup>1</sup>
$V_{\text{CCIN}}$	Input supply to Integrated Voltage Regulator	$V_{\text{CCIN}}$	1.47	1.8	1.85	V	2, 3
$VID\_STEP$	VID step size for VR12.5	$V_{\text{CCIN}}$ $V_{\text{CCD}}$	10			mV	10
$V_{\text{CCD}}$ (Standard)	I/O Voltage for DDR3 (Standard Voltage)	$V_{\text{CCD}}$	1.425	1.50	1.575	V	
$V_{\text{CCDL}}$ (Low)	I/O Voltage for DDR3L (Low Voltage)	$V_{\text{CCD}}$	1.283	1.35	1.451	V	
$V_{\text{CCIO\_IN}}$	I/O Voltage	$V_{\text{CCIO\_IN}}$	1.0	1.05	1.10	V	3, 5, 9
$V_{\text{CCPECI}}$	PECI Voltage	$V_{\text{CCPECI}}$	1.0	1.05	1.10	V	3, 5, 9

**Notes:**

- Unless otherwise noted, all specifications in this table apply to all processors in this processor family. Specifications are based on preliminary silicon characterization.



## Electrical Specifications

- Individual processor VID values may be calibrated during manufacturing such that two devices at the same speed may have different settings.
- Voltages are targets only. A variable voltage source should exist on systems in the event that a different voltage is required. A future processor may be developed requiring a nominal voltage 0.95V.
- The  $V_{CCIN}$  voltage specification requirements are measured across the remote sense pin pairs ( $V_{CCIN\_SENSE}$  and  $V_{SS\_VCCIN\_SENSE}$ ) on the processor package. Voltage measurement should be taken with a DC to 100 MHz bandwidth oscilloscope limit (or DC to 20 MHz for older model oscilloscopes), using a 1.5 pF maximum probe capacitance, and 1 M $\Omega$  minimum impedance. The maximum length of the ground wire on the probe should be less than 5 mm to ensure external noise from the system is not coupled in the scope probe.
- For the processor refer to [Table 2-12](#) and corresponding [Figure 2-2](#). The processor should not be subjected to any static  $V_{CCIN}$  level that exceeds the  $V_{CCIN\_MAX}$  associated with any particular current. Failure to adhere to this specification can shorten processor lifetime.
- Minimum  $V_{CCIN}$  and maximum  $I_{CCIN}$  are specified at the maximum processor case temperature ( $T_{CASE}$ ) shown in the processor TMSDG.  $I_{CCIN\_MAX}$  is specified at the relative  $V_{CCIN\_MAX}$  point on the  $V_{CCIN}$  Loadline. The processor is capable of drawing  $I_{CCIN\_MAX}$  for up to 4 milliseconds.
- This specification represents the  $V_{CCIN}$  increase or decrease due to each VID transition
- Baseboard bandwidth is limited to 20 MHz.
- DC + AC + Ripple specification
- $V_{CCIN}$  has a  $V_{BOOT}$  setting of 1.7 V and is included in the PWRGOOD indication.

**Table 2-11. Processor Power Supply Current Specifications**

Parameter and Definition	Processor TDP / Core count	TDC <sup>2</sup> (A)	Max (A)	P <sub>MAX</sub> <sup>5</sup> (W)	Notes <sup>1</sup>
$I_{CCIO\_IN}$ I/O Termination Supply, Processor Current on $V_{CCIO\_IN}$ , $V_{CCPECI}$	All Intel® Xeon® Processor E5-2400 v3 Product Family	.02	0.1		
$I_{CCD}$ <sup>3</sup> Memory Controller DDR3 Supply, Processor Current on $V_{CCD}$		5	7		3
$I_{CCIN}$ Integrated Voltage Regulator Supply Processor Current on $V_{CCIN}$	LV70W-10C	43	90	138	
	LV65W-8C 1S	40	83	128	
	LV55W-8C	34	70	109	
	LV50W-6C	28	57	88	
	LV45W-4C	25	51	78	

**Notes:**

- Unless otherwise noted, all specifications in this table apply to all models in the processor family. Specifications are based on preliminary silicon characterization.
- TDC (Thermal Design Current) is the sustained (DC equivalent) current that the processor is capable of drawing indefinitely and should be used for the voltage regulator thermal assessment. The voltage regulator is responsible for monitoring its temperature and asserting the necessary signal to inform the processor of a thermal excursion.
- $I_{CCD}$  specifications are current draw on  $V_{CCD}$  of processor only and do not include current consumption by memory devices.
- Minimum  $V_{CCIN}$  and maximum  $I_{CCIN}$  are specified at the maximum processor case temperature ( $T_{CASE}$ ).  $I_{CCIN\_MAX}$  is specified at the corresponding voltage point on the  $V_{CCIN}$  Loadline. The processor is capable of drawing  $I_{CCIN\_MAX}$  for up to 4 milliseconds.
- $P_{MAX}$  is provided for  $V_{CCIN}$  for ensuring adequate capability in design and sizing of the power delivery components.

### 2.9.2 $V_{CCIN}$ Power Delivery for Integrated Voltage Regulators

The  $V_{CCIN}$  voltage rail supplies the input source to the integrated voltage regulators powering cores, cache and system agents. This integration improves regulation of on-die voltages optimizing performance and power savings. The  $V_{CCIN}$  rail is supplied by an external voltage regulator.

Adhering to power delivery specifications is mandatory for ensuring long-term reliable operation of processors and system components. The Intel® Xeon® Processor E5-2400 v3 Product Family implements a 1.40-m $\Omega$  loadline with a tolerance band  $\pm 25$  mV. Static and Transient Tolerances are repeated here for convenience in [Table 2-12](#) and [Figure 2-2](#)

Table 2-12. Processor  $V_{CCIN}$  Static and Transient Tolerance

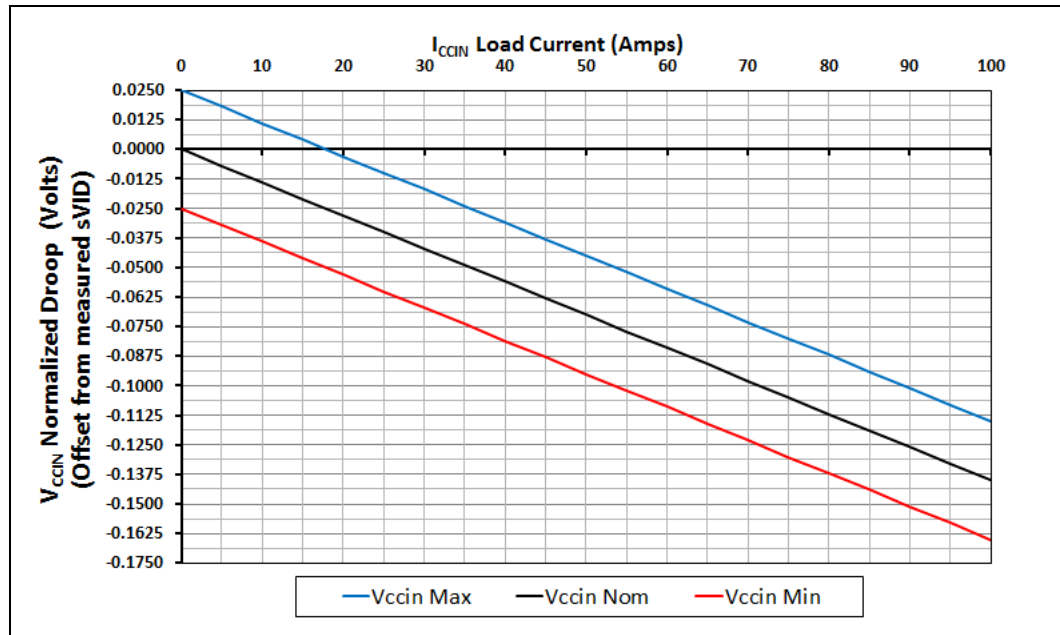
$I_{CCIN}$ [A]	$V_{CCIN\_Max}$ [V]	$V_{CCIN\_Nominal}$ [V]	$V_{CCIN\_Min}$ [V]	Notes
0	VID + 0.025	VID - 0.000	VID - 0.025	1,2,3,4
5	VID + 0.018	VID - 0.007	VID - 0.032	1,2,3,4
10	VID + 0.011	VID - 0.014	VID - 0.039	1,2,3,4
15	VID + 0.004	VID - 0.021	VID - 0.046	1,2,3,4
20	VID - 0.003	VID - 0.028	VID - 0.053	1,2,3,4
25	VID - 0.010	VID - 0.035	VID - 0.060	1,2,3,4
30	VID - 0.017	VID - 0.042	VID - 0.067	1,2,3,4
35	VID - 0.024	VID - 0.049	VID - 0.074	1,2,3,4
40	VID - 0.031	VID - 0.056	VID - 0.081	1,2,3,4
45	VID - 0.038	VID - 0.063	VID - 0.088	1,2,3,4
50	VID - 0.045	VID - 0.070	VID - 0.095	1,2,3,4
55	VID - 0.052	VID - 0.077	VID - 0.102	1,2,3,4
60	VID - 0.059	VID - 0.084	VID - 0.109	1,2,3,4
65	VID - 0.066	VID - 0.091	VID - 0.116	1,2,3,4
70	VID - 0.073	VID - 0.098	VID - 0.123	1,2,3,4
75	VID - 0.080	VID - 0.105	VID - 0.130	1,2,3,4
80	VID - 0.087	VID - 0.112	VID - 0.137	1,2,3,4
85	VID - 0.094	VID - 0.119	VID - 0.144	1,2,3,4
90	VID - 0.101	VID - 0.126	VID - 0.151	1,2,3,4
95	VID - 0.108	VID - 0.133	VID - 0.158	1,2,3,4
100	VID - 0.115	VID - 0.140	VID - 0.165	1,2,3,4

**Notes:**

1. The loadline specification includes both static and transient limits.
2. Table is intended to aid in reading discrete points on graph in [Figure 2-2](#).
3. The Loadlines specify voltage limits at the die measured at the  $V_{CCIN\_sense}$  and  $V_{SS\_VCCIN\_sense}$  lands. Voltage regulation feedback for voltage regulator circuits must be taken from processor  $V_{CCIN\_sense}$  and  $V_{SS\_VCCIN\_sense}$  lands.
4.  $I_{CCIN}$  range extends only to maximum value of the target processor as specified in [Table 2-11](#).



Figure 2-2.  $V_{CCIN}$  Static and Transient Tolerance Loadlines



### 2.9.3 Die Voltage Validation

$V_{CCIN}$  overshoot events at the processor must meet the specifications in Table 2-13 when measured across the VCCIN\_SENSE and VSS\_VCCIN\_SENSE lands. Overshoot events that are < 10 ns in duration may be ignored. These measurements of processor die level overshoot should be taken with a 100 MHz bandwidth limited oscilloscope.

#### 2.9.3.1 $V_{CCIN}$ Overshoot Specifications

The processor can tolerate short transient overshoot events where  $V_{CCIN}$  exceeds the VID voltage when transitioning from a high-to-low current load condition. This overshoot cannot exceed VID +  $V_{OS\_MAX}$  ( $V_{OS\_MAX}$  is the maximum allowable overshoot above VID). These specifications apply to the processor die voltage as measured across the VCCIN\_SENSE and VSS\_VCCIN\_SENSE lands.

Table 2-13.  $V_{CCIN}$  Overshoot Specifications

Symbol	Parameter	Max	Units	Figure	Notes
$V_{OS\_MAX}$	Magnitude of $V_{CCIN}$ overshoot above VID	75	mV	2-3	
$T_{OS\_MAX}$	Time duration of $V_{CCIN}$ overshoot above $V_{CCIN\_MAX}$ value at the new lighter load	25	$\mu$ s	2-3	

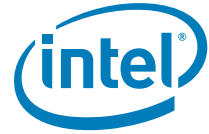
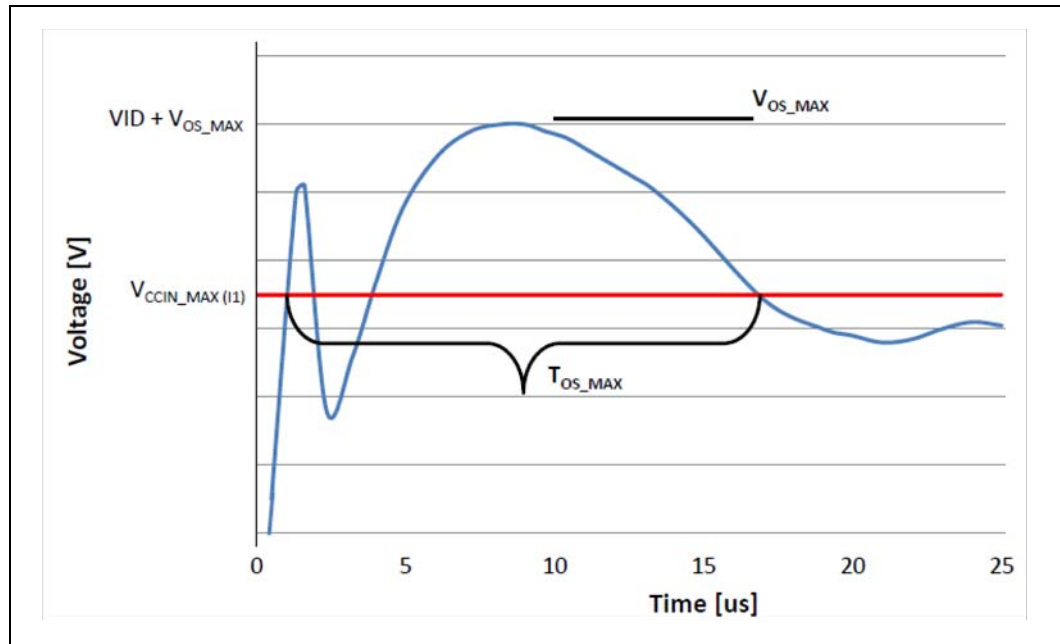


Figure 2-3. V<sub>CCIN</sub> Overshoot Example Waveform



**Notes:**

1. V<sub>OS\_MAX</sub> is the measured overshoot voltage.
2. T<sub>OS\_MAX</sub> is the measured time duration above V<sub>CCIN\_MAX(I1)</sub>.
3. Istep: Load Release Current Step, for example, I<sub>2</sub> to I<sub>1</sub>, where I<sub>2</sub> > I<sub>1</sub>.
4. V<sub>CCIN\_MAX(I1)</sub> = VID + TOB

### 2.9.4 Signal DC Specifications

**DC specifications are defined at the processor pads, unless otherwise noted.** DC specifications are only valid while meeting specifications for case temperature specified in the processor TMSDG, clock frequency, and input voltages. Care should be taken to read all notes associated with each specification.

Table 2-14. DDR3 and DDR3L Signal DC Specifications (Sheet 1 of 2)

Symbol	Parameter	Min	Nom	Max	Units	Notes <sup>1</sup>
I <sub>IL</sub>	Input Leakage Current	-1.4		+1.4	mA	10
<b>Data Signals</b>						
V <sub>IL</sub>	Input Low Voltage			0.43*V <sub>CCD</sub>	V	2, 3
V <sub>IH</sub>	Input High Voltage	0.57*V <sub>CCD</sub>			V	2, 4, 5
R <sub>ON</sub>	DDR3 Data Buffer On Resistance	21		31	Ω	6
Data ODT	On-Die Termination for Data Signals	45 90		55 110	Ω	8
PAR_ERR_N ODT	On-Die Termination for Parity Error Signals	100			Ω	
<b>Reference Clock Signals, Command, and Data Signals</b>						
V <sub>OL</sub>	Output Low Voltage	$(V_{CCD} / 2) * (R_{ON} / (R_{ON} + R_{VTT\_TERM}))$			V	2, 7
V <sub>OH</sub>	Output High Voltage	$V_{CCD} - ((V_{CCD} / 2) * (R_{ON} / (R_{ON} + R_{VTT\_TERM}))$			V	2, 5, 7
<b>Reference Clock Signal</b>						



**Table 2-14. DDR3 and DDR3L Signal DC Specifications (Sheet 2 of 2)**

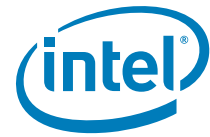
Symbol	Parameter	Min	Nom	Max	Units	Notes <sup>1</sup>
R <sub>ON</sub>	DDR3 Clock Buffer On Resistance	21		31	Ω	6
<b>Command Signals</b>						
R <sub>ON</sub>	DDR3 Command Buffer On Resistance	16		24	Ω	6
R <sub>ON</sub>	DDR3 Reset Buffer On Resistance	25		75	Ω	6
V <sub>OL_CMOS1.5v</sub>	Output Low Voltage DDR_RESET_C{01/23}_N			0.2*V <sub>CCD</sub>	V	1,2
V <sub>OH_CMOS1.5v</sub>	Output High Voltage DDR_RESET_C{01/23}_N	0.9*V <sub>CCD</sub>			V	1,2
I <sub>IL_CMOS1.5v</sub>	Input Leakage Current	-100		+100	μA	1,2
<b>Control Signals</b>						
R <sub>ON</sub>	DDR3 Control Buffer On Resistance	21		31	Ω	6
DDR01_RCOMP[0]	COMP Resistance	128.7	130	131.3	Ω	9,12
DDR01_RCOMP[1]	COMP Resistance	39.8	40.2	40.6	Ω	9,12
DDR01_RCOMP[2]	COMP Resistance	119.8	121	122.2	Ω	9,12
DDR23_RCOMP[0]	COMP Resistance	128.7	130	131.3	Ω	9,12
DDR23_RCOMP[1]	COMP Resistance	39.8	40.2	40.6	Ω	9,12
DDR23_RCOMP[2]	COMP Resistance	119.8	121	122.2	Ω	9,12
<b>DDR3 Miscellaneous Signals</b>						
V <sub>IL</sub>	Input Low Voltage DRAM_PWR_OK_C{01/23}			0.55*V <sub>CCD</sub> + 0.2	V	2, 3, 11, 13
V <sub>IH</sub>	Input High Voltage DRAM_PWR_OK_C{01/23}	0.55*V <sub>CCD</sub> + 0.3			V	2, 4, 5, 11, 13

**Notes:**

- Unless otherwise noted, all specifications in this table apply to all processor frequencies.
- The voltage rail V<sub>CCD</sub> which will be set to 1.50 V or 1.35 V nominal depending on the voltage of all DIMMs connected to the processor.
- V<sub>IL</sub> is the maximum voltage level at a receiving agent that will be interpreted as a logical low value.
- V<sub>IH</sub> is the minimum voltage level at a receiving agent that will be interpreted as a logical high value.
- V<sub>IH</sub> and V<sub>OH</sub> may experience excursions above V<sub>CCD</sub>. However, input signal drivers must comply with the signal quality specifications.
- This is the pull down driver resistance. Refer to processor signal integrity models for I/V characteristics. Reset drive does not have a termination.
- R<sub>VTT\_TERM</sub> is the termination on the DIMM and not controlled by the processor. Refer to the applicable DIMM datasheet.
- The minimum and maximum values for these signals are programmable by BIOS to one of the pairs.
- COMP resistance must be provided on the system board with 1% resistors. See the *Platform Design Guide* for implementation details. DDR01\_RCOMP[2:0] and DDR23\_RCOMP[2:0] resistors are terminated to VSS.
- Input leakage current is specified for all DDR3 signals.
- DRAM\_PWR\_OK\_C{01/23} must have a maximum of 30 ns rise or fall time over V<sub>CCD</sub> \* 0.55 + 300 mV and -200 mV and the edge must be monotonic.
- The DDR{01/23}\_RCOMP error tolerance is ±15% from the compensated value.
- DRAM\_PWR\_OK\_C{01/23}: Data Scrambling must be enabled for production environments. Disabling Data scrambling is supported only for debug and testing purposes. Operation of systems with Data Scrambling disabled violates specification.

**Table 2-15. PECEI DC Specifications (Sheet 1 of 2)**

Symbol	Definition and Conditions	Min	Max	Units	Figure	Notes <sup>1</sup>
V <sub>In</sub>	Input Voltage Range	-0.150	V <sub>CCPECEI</sub> + 0.150	V		
V <sub>Hysteresis</sub>	Hysteresis	0.100 * V <sub>CCPECEI</sub>		V		
V <sub>N</sub>	Negative-edge threshold voltage	0.275 * V <sub>CCPECEI</sub>	0.500 * V <sub>CCPECEI</sub>	V	2-1	2
V <sub>P</sub>	Positive-edge threshold voltage	0.550 * V <sub>CCPECEI</sub>	0.725 * V <sub>CCPECEI</sub>	V	2-1	2



**Table 2-15. PECEI DC Specifications (Sheet 2 of 2)**

Symbol	Definition and Conditions	Min	Max	Units	Figure	Notes <sup>1</sup>
I <sub>SOURCE</sub>	High level output source V <sub>OH</sub> = 0.75 * V <sub>CCPECEI</sub>	-6.0		mA		
I <sub>Leak+</sub>	High impedance state leakage to V <sub>CCPECEI</sub> (V <sub>leak</sub> = V <sub>OL</sub> )	50	200	μA		3
R <sub>ON</sub>	Buffer On Resistance	20	36	Ω		
C <sub>Bus</sub>	Bus capacitance per node		10	pF		4,5
V <sub>Noise</sub>	Signal noise immunity above 300 MHz	0.100 * V <sub>CCPECEI</sub>		V <sub>p-p</sub>		
	Output Edge Rate (50 ohm to V <sub>SS</sub> , between V <sub>IL</sub> and V <sub>IH</sub> )	1.5	4	V/ns		

**Notes:**

- V<sub>CCPECEI</sub> supplies the PECEI interface. PECEI behavior does not affect V<sub>CCPECEI</sub> min/max specification
- It is expected that the PECEI driver will take into account, the variance in the receiver input thresholds and consequently, be able to drive its output within safe limits (-0.150 V to 0.275\*V<sub>CCPECEI</sub> for the low level and 0.725\*V<sub>CCPECEI</sub> to V<sub>CCPECEI</sub>+0.150 V for the high level).
- The leakage specification applies to powered devices on the PECEI bus.
- One node is counted for each client and one node for the system host. Extended trace lengths might appear as additional nodes.
- Excessive capacitive loading on the PECEI line may slow down the signal rise/fall times and consequently limit the maximum bit rate at which the interface can operate.

**Table 2-16. System Reference Clock (BCLK{0/1}) DC Specifications**

Symbol	Parameter	Min	Max	Unit	Figure	Notes <sup>1</sup>
V <sub>BCLK_diff_ih</sub>	Input High Voltage (Differential)	0.150		V	2-7	
V <sub>BCLK_diff_il</sub>	Input Low Voltage (Differential)		-0.150	V	2-7	
V <sub>cross (abs)</sub>	Absolute Crossing Point (Single Ended)	0.25	0.55	V	2-4 2-8	2, 4, 7
V <sub>cross(rel)</sub>	Relative Crossing Point (Single Ended)	0.25 + 0.5*(V <sub>Havg</sub> - 0.7)	0.55 + 0.5*(V <sub>Havg</sub> - 0.7)	V	2-4	3, 4, 5
ΔV <sub>cross</sub>	Range of Crossing Points (Single Ended)		0.140	V	2-9	6
V <sub>TH</sub>	Threshold Voltage (Single Ended)	V <sub>cross</sub> - 0.1	V <sub>cross</sub> + 0.1	V		
I <sub>IL</sub>	Input Leakage Current		1.50	μA		8
C <sub>pad</sub>	Pad Capacitance	1.12	1.70	pF		

**Notes:**

- Specifications apply to all processor frequencies. Parameters are specified at the processor pad.
- Crossing Voltage is defined as the instantaneous voltage value when the rising edge of BCLK{0/1}\_DN is equal to the falling edge of BCLK{0/1}\_DP.
- V<sub>Havg</sub> is the statistical average of the VH measured by the oscilloscope.
- The crossing point must meet the absolute and relative crossing point specifications simultaneously.
- V<sub>Havg</sub> can be measured directly using "Vtop" on Agilent\* and "High" on Tektronix oscilloscopes.
- V<sub>CROSS</sub> is defined as the total variation of all crossing voltages as defined in Note 3.
- The rising edge of BCLK{0/1}\_DN is equal to the falling edge of BCLK{0/1}\_DP.
- For Vin between 0 and Vih.

**Table 2-17. SMBus DC Specifications (Sheet 1 of 2)**

Symbol	Parameter	Min	Max	Units	Notes
V <sub>IL</sub>	Input Low Voltage		0.3*V <sub>CCIO_IN</sub>	V	
V <sub>IH</sub>	Input High Voltage	0.7*V <sub>CCIO_IN</sub>		V	
V <sub>Hysteresis</sub>	Hysteresis	0.1*V <sub>CCIO_IN</sub>		V	





**Table 2-17. SMBus DC Specifications (Sheet 2 of 2)**

Symbol	Parameter	Min	Max	Units	Notes
V <sub>OL</sub>	Output Low Voltage		0.2*V <sub>CCIO_IN</sub>	V	
R <sub>ON</sub>	Buffer On Resistance	4	14	Ω	
I <sub>L</sub>	Leakage Current	50	200	μA	
	Output Edge Rate (50 ohm to V <sub>CCIO_IN</sub> , between V <sub>IL</sub> and V <sub>IH</sub> )	0.05	0.6	V/ns	

**Table 2-18. JTAG and TAP Signals DC Specifications**

Symbol	Parameter	Min	Max	Units	Notes
V <sub>IL</sub>	Input Low Voltage		0.4*V <sub>CCIO_IN</sub>	V	
V <sub>IH</sub>	Input High Voltage	0.8*V <sub>CCIO_IN</sub>		V	
V <sub>IL</sub>	Input Low Voltage: TCK		0.4*V <sub>CCIO_IN</sub>	V	
V <sub>IH</sub>	Input High Voltage: TCK	0.6*V <sub>CCIO_IN</sub>		V	
V <sub>OL</sub>	Output Low Voltage		0.2*V <sub>CCIO_IN</sub>	V	
V <sub>Hysteresis</sub>	Hysteresis	0.1*V <sub>CCIO_IN</sub>		V	
R <sub>ON</sub>	Buffer On Resistance BPM_N[7:0], PRDY_N, TDO	4	14	Ω	
I <sub>IL</sub>	Input Leakage Current	50	200	μA	
	Input Edge Rate BPM_N[7:0], EAR_N, PREQ_N, TCK, TDI, TMS, TRST_N	0.05		V/ns	1, 2
	Output Edge Rate (50 ohm to V <sub>CCIO_IN</sub> ) BPM_N[7:0], PRDY_N, TDO	0.2	1.5	V/ns	1

**Note:**

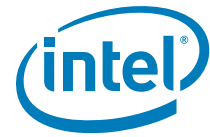
1. Measured between V<sub>IL</sub> and V<sub>IH</sub>.
2. Edge rate must be met or the signal must transition monotonically to the asserted state.

**Table 2-19. Serial VID Interface (SVID) DC Specifications**

Symbol	Parameter	Min	Nom	Max	Units	Notes
V <sub>IL</sub>	Input Low Voltage SVIDDATA, SVIDALERT_N			0.4*V <sub>CCIO_IN</sub>	V	1
V <sub>IH</sub>	Input High Voltage SVIDDATA, SVIDALERT_N	0.7*V <sub>CCIO_IN</sub>			V	1
V <sub>OL</sub>	Output Low Voltage SVIDCLK, SVIDDATA			0.2*V <sub>CCIO_IN</sub>	V	1
V <sub>Hysteresis</sub>	Hysteresis	0.05*V <sub>CCIO_IN</sub>			V	1
R <sub>ON</sub>	Buffer On Resistance SVIDCLK, SVIDDATA	4		14	Ω	2
I <sub>IL</sub>	Input Leakage Current	50		200	μA	3,4
	Input Edge Rate SVIDALERT_N	0.05			V/ns	5, 6
	Output Edge Rate (50 ohm to V <sub>CCIO_IN</sub> )	0.20		1.5	V/ns	5

**Notes:**

1. V<sub>CCIO\_IN</sub> refers to instantaneous V<sub>CCIO\_IN</sub>.
2. Measured at 0.31\*V<sub>CCIO\_IN</sub>
3. Vin between 0V and V<sub>CCIO\_IN</sub>
4. Refer to the *Platform Design Guide* for routing design guidelines.
5. These are measured between V<sub>IL</sub> and V<sub>IH</sub>.
6. The signal edge rate must be met or the signal must transition monotonically to the asserted state.



**Table 2-20. Processor Asynchronous Sideband DC Specifications**

Symbol	Parameter	Min	Max	Units	Notes
<b>CMOS1.05v Signals</b>					
$V_{IL\_CMOS1.05v}$	Input Low Voltage		$0.4 * V_{CCIO\_IN}$	V	1,2
$V_{IH\_CMOS1.05v}$	Input High Voltage	$0.6 * V_{CCIO\_IN}$		V	1,2
$I_{IL\_CMOS1.05v}$	Input Leakage Current	50	200	$\mu A$	1,2
<b>Open Drain CMOS (ODCMOS) Signals</b>					
$V_{IL\_ODCMOS}$	Input Low Voltage MEM_HOT_C{01/23}_N, PROCHOT_N		$0.3 * V_{CCIO\_IN}$	V	1,2
$V_{IL\_ODCMOS}$	Input Low Voltage CATERR_N, MSMI_N, PM_FAST_WAKE_N		$0.4 * V_{CCIO\_IN}$	V	1,2
$V_{IH\_ODCMOS}$	Input High Voltage	$0.7 * V_{CCIO\_IN}$		V	1,2
$V_{OL\_ODCMOS}$	Output Low Voltage		$0.2 * V_{CCIO\_IN}$	V	1,2
$V_{Hysteresis}$	Hysteresis MEM_HOT_{C01/23}_N, PROCHOT_N	$0.1 * V_{CCIO\_IN}$		V	1,2
$V_{Hysteresis}$	Hysteresis CATERR_N, MSMI_N, PM_FAST_WAKE_N	$0.05 * V_{CCIO\_IN}$		V	1,2
$I_{Leak}$	Input Leakage Current	50	200	$\mu A$	
$R_{ON}$	Buffer On Resistance	4	14	$\Omega$	1,2
	Output Edge Rate MEM_HOT_C{01/23}_N, ERROR_N[2:0], THERMTRIP, PROCHOT_N	0.05	0.60	V/ns	3
	Output Edge Rate CATERR_N, MSMI_N, PM_FAST_WAKE_N	0.2	1.5	V/ns	3

**Notes:**

1. This table applies to the processor sideband and miscellaneous signals specified in Table 2-4.
2. Unless otherwise noted, all specifications in this table apply to all processor frequencies.
3. These signals are measured between  $V_{IL}$  and  $V_{IH}$ .

**Table 2-21. Miscellaneous Signals DC Specifications**

Symbol	Parameter	Min	Typical	Max	Units	Notes
<b>PROC_ID_N</b>						
$V_{O\_ABS\_MAX}$	Output Absolute Max Voltage			1.80	V	1, 2
$I_o$	Output Current		N/A			1, 2
<b>SKTOCC_N</b>						
$V_{O\_ABS\_MAX}$	Output Absolute Max Voltage		3.30	3.50	V	1
$I_{OMAX}$	Output Max Current			1	mA	1

**Notes:**

1. For specific routing guidelines, see the Platform Design Guide for details.
2. PROC\_ID\_N land is unconnected within the package.

**2.9.4.1 PCI Express\* DC Specifications**

The processor DC specifications for the PCI Express\* are available in the *PCI Express Base Specification - Revision 3.0*. This document will provide only the processor exceptions to the *PCI Express Base Specification - Revision 3.0*.



### 2.9.4.2 DMI2/PCI Express\* DC Specifications

The processor DC specifications for the DMI2/PCI Express\* are available in the *PCI Express Base Specification 2.0 and 1.0*. This document will provide only the processor exceptions to the *PCI Express Base Specification 2.0 and 1.0*.

### 2.9.4.3 Intel® QuickPath Interconnect DC Specifications

Intel® QuickPath Interconnect specifications are defined at the processor lands. Refer to the *Platform Design Guide* for specific implementation details. In most cases, termination resistors are not required as these are integrated into the processor silicon.

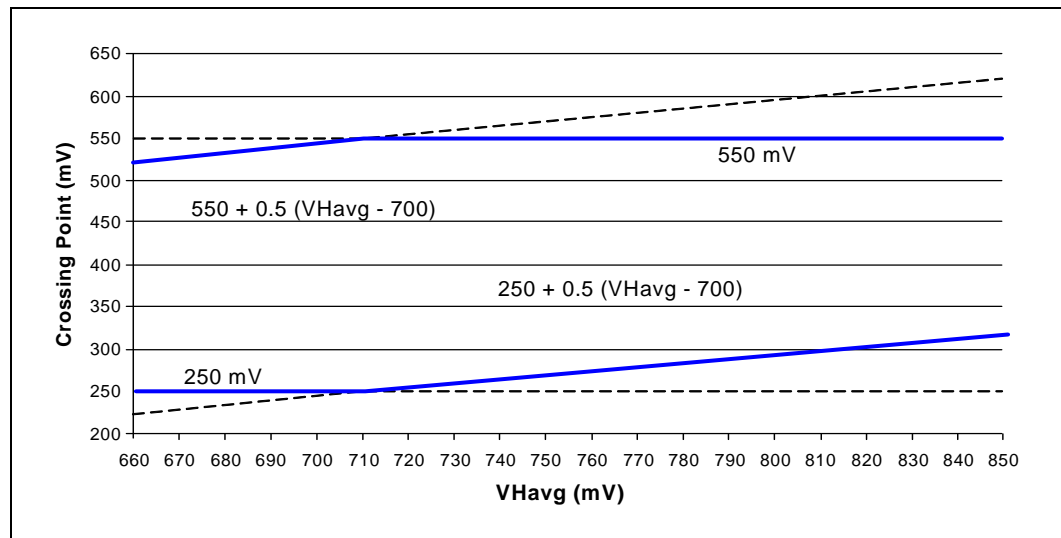
The processor DC specifications for the Intel® QPI interface are available in the *Intel® QuickPath Interconnect V1.1 Base Electrical Specification and Validation Methodologies*. This document will provide only the processor exceptions to the *Intel® QuickPath Interconnect V1.1 Base Electrical Specification and Validation Methodologies*.

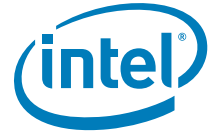
### 2.9.4.4 Reset and Miscellaneous Signal DC Specifications

For a power-on Reset, RESET\_N must stay active for at least 3.5 millisecond after V<sub>CCIN</sub> and BCLK{0/1} have reached their proper specifications. RESET\_N must not be kept asserted for more than 100 ms while PWRGOOD is asserted. RESET\_N must be held asserted for at least 3.5 millisecond before it is deasserted again. RESET\_N must be held asserted before PWRGOOD is asserted. This signal does not have on-die termination and must be terminated on the system board.

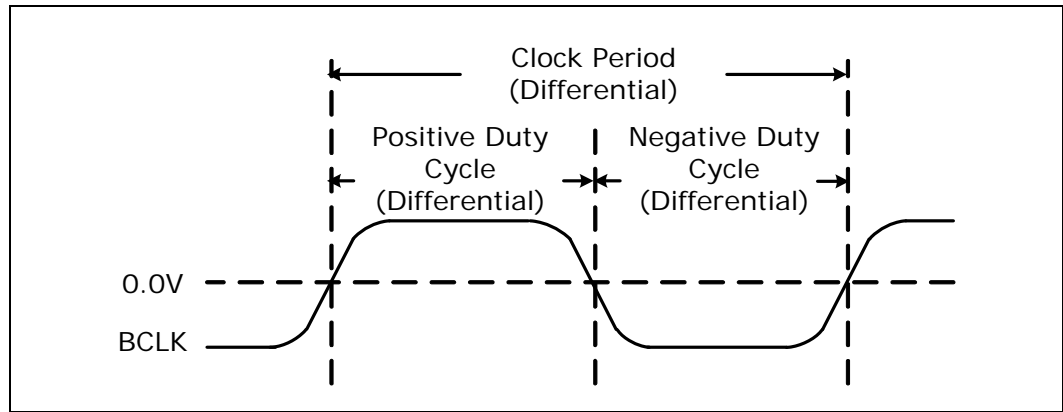
## 2.10 System Reference Clock (BCLK{0/1}) Waveforms

Figure 2-4. BCLK{0/1} Differential Clock Crosspoint Specification

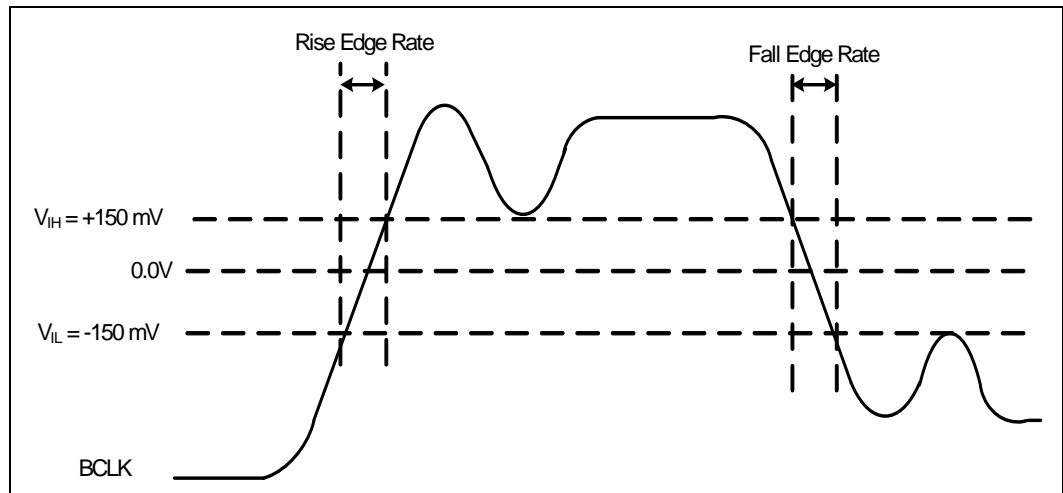




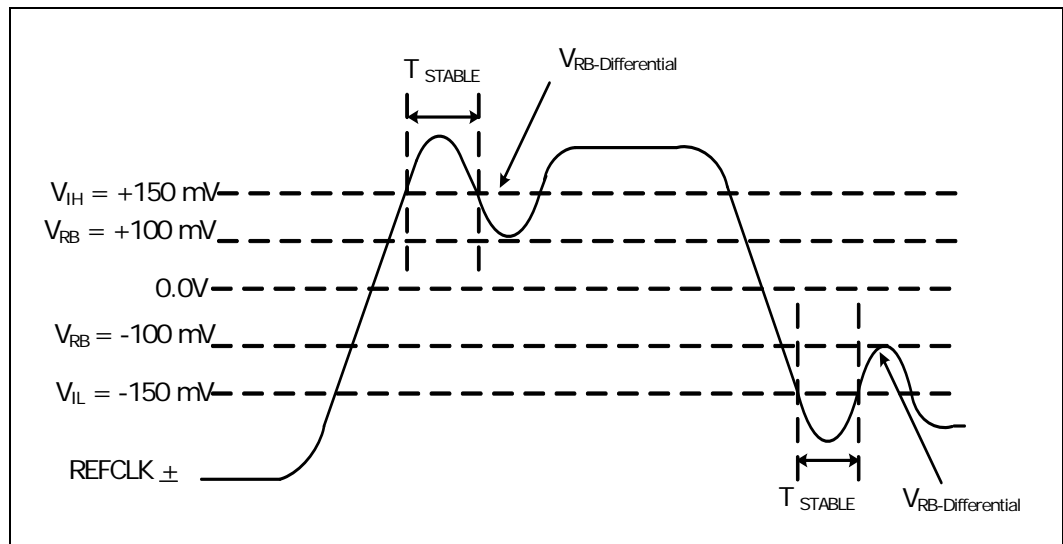
**Figure 2-5. BCLK{0/1} Differential Clock Measurement Points for Duty Cycle and Period**



**Figure 2-6. BCLK{0/1} Differential Clock Measurement Points for Edge Rate**

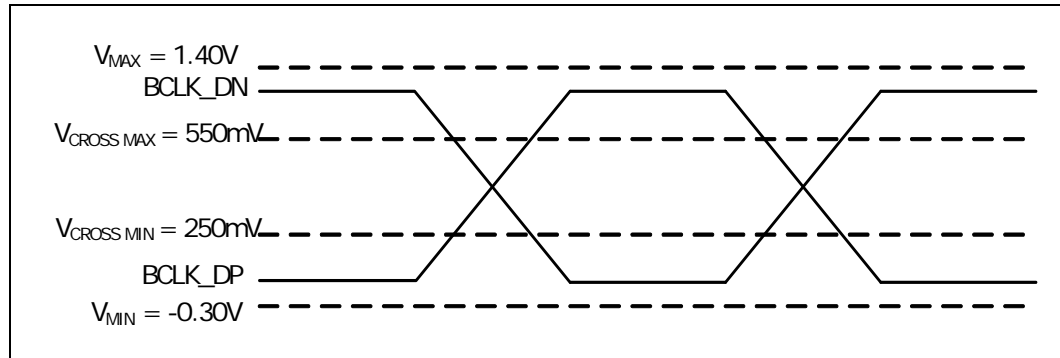


**Figure 2-7. BCLK{0/1} Differential Clock Measurement Point for Ringback**

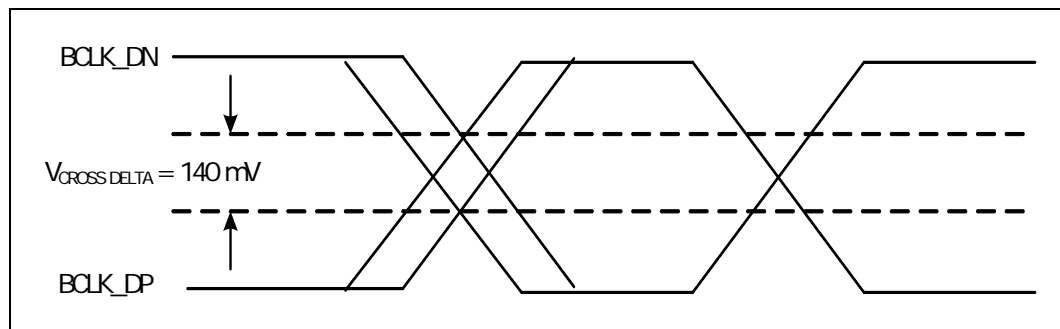




**Figure 2-8. BCLK{0/1} Single Ended Clock Measurement Points for Absolute Cross Point and Swing**



**Figure 2-9. BCLK{0/1} Single Ended Clock Measurement Points for Delta Cross Point**



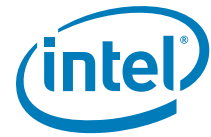
## 2.11 Signal Quality

Data transfer requires the clean reception of data signals and clock signals. Ringing below receiver thresholds, non-monotonic signal edges, and excessive voltage swings will adversely affect system timings. Ringback and signal non-monotonicity cannot be tolerated since these phenomena may inadvertently advance receiver state machines. Excessive signal swings (overshoot and undershoot) are detrimental to silicon gate oxide integrity, and can cause device failure if absolute voltage limits are exceeded. Overshoot and undershoot can also cause timing degradation due to the build up of inter-symbol interference (ISI) effects.

For these reasons, it is crucial that the designer work towards a solution that provides acceptable signal quality across all systematic variations encountered in volume manufacturing.

This section documents signal quality metrics used to derive topology and routing guidelines through simulation. All specifications are specified at the processor die (pad measurements).

Specifications for signal quality are for measurements at the processor core only and are only observable through simulation. Therefore, proper simulation is the only way to verify proper timing and signal quality.



### 2.11.1 DDR3 Signal Quality Specifications

Various scenarios for the DDR3 Signals have been simulated to generate a set of layout guidelines which are available in the *Platform Design Guide*.

Overshoot (or undershoot) is the absolute value of the maximum voltage above or below  $V_{SS}$ . The overshoot/undershoot specifications limit transitions beyond specified maximum voltages or  $V_{SS}$  due to the fast signal edge rates. The processor can be damaged by single and/or repeated overshoot or undershoot events on any input, output, or I/O buffer if the charge is large enough (i.e., if the over/undershoot is great enough). Baseboard designs which meet signal integrity and timing requirements and which do not exceed the maximum overshoot or undershoot limits listed in [Table 2-22](#) will insure reliable IO performance for the lifetime of the processor.

### 2.11.2 I/O Signal Quality Specifications

Signal Quality specifications for PCIe Signals are included as part of the PCIe DC specifications and PCIe AC specifications. Various scenarios have been simulated to generate a set of layout guidelines which are available in the *Platform Design Guide*.

### 2.11.3 Intel® QuickPath Interconnect Signal Quality Specifications

Signal Quality specifications for Differential Intel® QuickPath Interconnect Signals are included as part of the Intel® QuickPath Interconnect defined in the *Intel® QuickPath Interconnect V1.1 Base Electrical Specification and Validation Methodologies*. Various scenarios have been simulated to generate a set of layout guidelines which are available in the *Platform Design Guide*.

### 2.11.4 Input Reference Clock Signal Quality Specifications

Overshoot/Undershoot and Ringback specifications for  $BCLK\{0/1\}_D[N/P]$  are found in [Table 2-22](#). Overshoot/Undershoot and Ringback specifications for the DDR3 Reference Clocks are specified by the DIMM.

### 2.11.5 Overshoot/Undershoot Tolerance

Overshoot (or undershoot) is the absolute value of the maximum voltage above or below  $V_{SS}$ , see [Figure 2-10](#). The overshoot/undershoot specifications limit transitions beyond  $V_{CCD}$  or  $V_{SS}$  due to the fast signal edge rates. The processor can be damaged by single and/or repeated overshoot or undershoot events on any input, output, or I/O buffer if the charge is large enough (that is, if the over/undershoot is great enough). Determining the impact of an overshoot/undershoot condition requires knowledge of the magnitude, the pulse direction, and the activity factor (AF). Permanent damage to the processor is the likely result of excessive overshoot/undershoot.

Baseboard designs which meet signal integrity and timing requirements and which do not exceed the maximum overshoot or undershoot limits listed in [Table 2-22](#) will insure reliable IO performance for the lifetime of the processor.

**Table 2-22. Processor I/O Overshoot/Undershoot Specifications (Sheet 1 of 2)**

Signal Group	Minimum Undershoot	Maximum Overshoot	Overshoot Duration	Undershoot Duration	Notes
Intel® QuickPath Interconnect	$-0.2 * V_{CCIO\_IN}$	$1.2 * V_{CCIO\_IN}$	39 ps	15 ps	1,2



Table 2-22. Processor I/O Overshoot/Undershoot Specifications (Sheet 2 of 2)

Signal Group	Minimum Undershoot	Maximum Overshoot	Overshoot Duration	Undershoot Duration	Notes
DDR3	$-0.2 * V_{CCD}$	$1.2 * V_{CCD}$	$0.25 * T_{CH}$	$0.1 * T_{CH}$	1,2,3
System Reference Clock (BCLK{0/1})	-0.3V	1.15V	N/A	N/A	1,2
PWRGOOD Signal	-0.42V	$V_{CCIO\_IN} + 0.28$	1.25 ns	0.5 ns	4

**Notes:**

1. These specifications are measured at the processor pad.
2. Refer to [Figure 2-10](#) for description of allowable Overshoot/Undershoot magnitude and duration.
3. TCH is the minimum high pulse width duration.
4. For PWRGOOD DC specifications see [Table 2-20](#).

### 2.11.5.1 Overshoot/Undershoot Magnitude

Overshoot/Undershoot magnitude describes the maximum potential difference between a signal and its voltage reference level. For the processor, both overshoot and undershoot magnitude are referenced to  $V_{SS}$ . It is important to note that the overshoot and undershoot conditions are separate and their impact must be determined independently.

The pulse magnitude and duration, and activity factor must be used to determine if the overshoot/undershoot pulse is within specifications.

### 2.11.5.2 Overshoot/Undershoot Pulse Duration

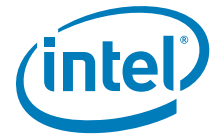
Overshoot/undershoot pulse duration describes the total amount of time that an overshoot/undershoot event exceeds the overshoot/undershoot reference voltage. The total time could encompass several oscillations above the reference voltage. Multiple overshoot/undershoot pulses within a single overshoot/undershoot event may need to be measured to determine the total pulse duration.

**Note:** Oscillations below the reference voltage cannot be subtracted from the total overshoot/undershoot pulse duration.

### 2.11.5.3 Activity Factor

Activity factor (AF) describes the frequency of overshoot (or undershoot) occurrence relative to a clock. Since the highest frequency of assertion of any common clock signal is every other clock, an AF = 0.1 indicates that the specific overshoot (or undershoot) waveform occurs every other clock cycle.

The specification provided in the table shows the maximum pulse duration allowed for a given overshoot/undershoot magnitude at a specific activity factor. Each table entry is independent of all others, meaning that the pulse duration reflects the existence of overshoot/undershoot events of that magnitude ONLY. A platform with an overshoot/undershoot that just meets the pulse duration for a specific magnitude where the AF < 0.1, means that there can be no other overshoot/undershoot events, even of lesser magnitude (note that if AF = 0.1, then the event occurs at all times and no other events can occur).



#### 2.11.5.4 Reading Overshoot/Undershoot Specification Tables

The overshoot/undershoot specification for the processor is not a simple single value. Instead, many factors are needed to determine the over/undershoot specification. In addition to the magnitude of the overshoot, the following parameters must also be known: the width of the overshoot and the activity factor (AF). To determine the allowed overshoot for a particular overshoot event, the following must be done:

1. Determine the signal group a particular signal falls into.
2. Determine the magnitude of the overshoot or the undershoot (relative to VSS).
3. Determine the activity factor (How often does this overshoot occur?).
4. Next, from the appropriate specification table, determine the maximum pulse duration (in nanoseconds) allowed.
5. Compare the specified maximum pulse duration to the signal being measured. If the pulse duration measured is less than the pulse duration shown in the table, then the signal meets the specifications.

Undershoot events must be analyzed separately from overshoot events as they are mutually exclusive.

#### 2.11.5.5 Compliance to Overshoot/Undershoot Specifications

The overshoot/undershoot specifications listed in the table specify the allowable overshoot/undershoot for a single overshoot/undershoot event. However, most systems will have multiple overshoot and/or undershoot events that each have their own set of parameters (duration, AF and magnitude). While each overshoot on its own may meet the overshoot specification, when you add the total impact of all overshoot events, the system may fail. A guideline to ensure a system passes the overshoot and undershoot specifications is shown below.

1. If only one overshoot/undershoot event magnitude occurs, ensure it meets the over/undershoot specifications in the following tables, OR
2. If multiple overshoots and/or multiple undershoots occur, measure the worst case pulse duration for each magnitude and compare the results against the AF = 0.1 specifications. If all of these worst case overshoot or undershoot events meet the specifications (measured time < specifications) in the table (where AF= 0.1), then the system passes.

**Table 2-23. Processor Sideband Signal Group Overshoot/Undershoot Tolerance**

Absolute Maximum Overshoot (V)	Absolute Maximum Undershoot (V)	Pulse Duration (ns) AF=0.1	Pulse Duration (ns) AF=0.01
1.3335 V	0.2835 V	3 ns	5 ns
1.2600 V	0.210 V	5 ns	5 ns



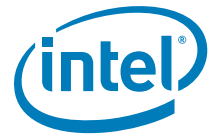
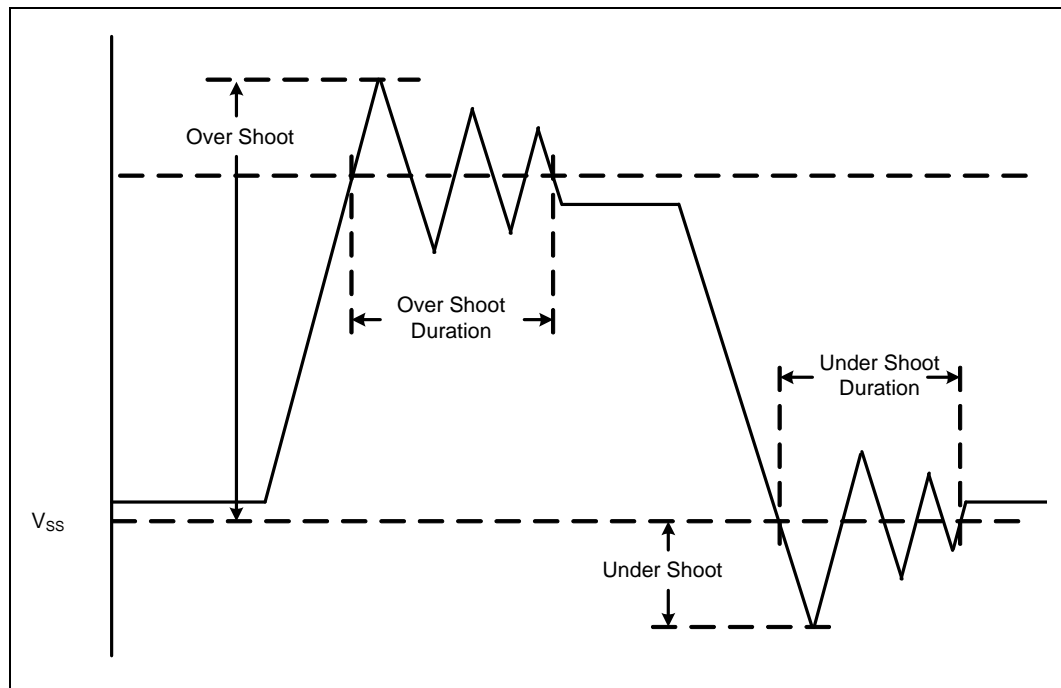
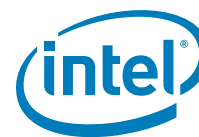


Figure 2-10. Maximum Acceptable Overshoot/Undershoot Waveform





## 2.12 C-State Power

Table 2-24 lists the package level C-State power specifications for each processor SKUs.

This represents the total power dissipated by the processor component in each C-State.

**Table 2-24. Processor Package C-State Power Specifications**

Processor TDP / Core count <sup>1</sup>	C1E (W) <sup>3</sup>	C3 (W) <sup>3</sup>	C6 (W) <sup>2</sup>
LV70W-10C	35	28	13
LV65W-8C 1S	30	24	13
LV55W-8C	30	24	12
LV50W-6C	27	23	12
LV45W-4C	27	23	12

**Notes:**

1. SKUs are subject to change. Contact your Intel Field Representative to obtain the latest SKU information.
2. Package C6 power specified at Tcase = 50°C.
3. C1E and C3 power values are characterized not tested.

§



## 3 Signal Descriptions

This chapter describes the processor signals. They are arranged in functional groups according to their associated interface or category.

### 3.1 System Memory Interface Signals

**Table 3-1. Memory Channel DDR1, DDR2, DDR3**

Signal Name	Description
DDR{1/2/3}_BA[2:0]	Bank Address. Defines the bank which is the destination for the current Activate, Read, Write, or Precharge command.
DDR{1/2/3}_CAS_N	Column Address Strobe.
DDR{1/2/3}_CKE[3:0]	Clock Enable.
DDR{1/2/3}_CLK_DN[3:0] DDR{1/2/3}_CLK_DP[3:0]	Differential clocks to the DIMM. All command and control signals are valid on the rising edge of clock.
DDR{1/2/3}_CS_N[7:0]	Chip Select. Each signal selects one rank as the target of the command and address.
DDR{1/2/3}_DQ[63:0]	Data Bus. DDR3 Data bits.
DDR{1/2/3}_DQS_P[17:0] DDR{1/2/3}_DQS_N[17:0]	Data strobes. Differential pair, Data/ECC Strobe. Differential strobes latch data/ECC for each DRAM. Different numbers of strobes are used depending on whether the connected DRAMs are x4,x8. Driven with edges in center of data, receive edges are aligned with data edges.
DDR{1/2/3}_ECC[7:0]	Check bits. An error correction code is driven along with data on these lines for DIMMs that support that capability
DDR{1/2/3}_MA[15:0]	Memory Address. Selects the Row address for Reads and writes, and the column address for activates. Also used to set values for DRAM configuration registers.
DDR{1/2/3}_PAR	Odd parity across Address and Command.
DDR{1/2/3}_ODT[3:0]	On Die Termination. Enables DRAM on die termination during Data Write or Data Read transactions.
DDR{1/2/3}_PAR_ERR_N	Parity Error detected by Registered DIMM (one for each channel).
DDR{1/2/3}_RAS_N	Row Address Strobe.
DDR{1/2/3}_WE_N	Write Enable.



Table 3-2. Memory Channel Miscellaneous

Signal Name	Description
DDR_RESET_C01_N DDR_RESET_C23_N	System memory reset: Reset signal from processor to DRAM devices on the DIMMs. DDR_RESET_C01_N is used for memory channel1 while DDR_RESET_C23_N is used for memory channels 2 and 3.
DDR_SCL_C01 DDR_SCL_C23	SMBus clock for the dedicated interface to the serial presence detect (SPD) and thermal sensors (TSoD) on the DIMMs. DDR_SCL_C01 is used for memory channel1 while DDR_SCL_C23 is used for memory channels 2 and 3.
DDR_SDA_C01 DDR_SDA_C23	SMBus data for the dedicated interface to the serial presence detect (SPD) and thermal sensors (TSoD) on the DIMMs. DDR_SDA_C01 is used for memory channel1 while DDR_SDA_C23 is used for memory channels 2 and 3.
DDR01_VREF DDR23_VREF	Voltage reference for system memory reads. DDR01_VREF is used for memory channel1 while DDR23_VREF is shared by memory channels 2 and 3.
DDR01_VREFDQ[1] DDR23_VREFDQ[1:0]	Voltage reference for system memory writes. DDR01_VREFDQ[1] is used for memory channel1. DDR23_VREFDQ[0] is used for channel 2 and DDR23_VREFDQ[1] for channel 3. These signal levels are adjusted by MRC to optimize timing margins.
DDR{01/23}_RCOMP[2:0]	System memory impedance compensation. Impedance compensation must be terminated on the system board using a precision resistor. See the <i>Platform Design Guide</i> for implementation details.
DRAM_PWR_OK_C01 DRAM_PWR_OK_C23	Power good input signal used to indicate that the VCCD power supply is stable for memory channel 1 and channels 2 & 3.

### 3.2 PCI Express\* Based Interface Signals

**Note:** PCI Express\* Ports 1 and 3 Signals are receive and transmit differential pairs.

Table 3-3. PCI Express\* Port 1 Signals

Signal Name	Description
PE1A_RX_DN[3:0] PE1A_RX_DP[3:0]	PCIe Receive Data Input
PE1B_RX_DN[7:4] PE1B_RX_DP[7:4]	PCIe Receive Data Input
PE1A_TX_DN[3:0] PE1A_TX_DP[3:0]	PCIe Transmit Data Output
PE1B_TX_DN[7:4] PE1B_TX_DP[7:4]	PCIe Transmit Data Output

Table 3-4. PCI Express\* Port 3 Signals (Sheet 1 of 2)

Signal Name	Description
PE3A_RX_DN[3:0] PE3A_RX_DP[3:0]	PCIe Receive Data Input
PE3B_RX_DN[7:4] PE3B_RX_DP[7:4]	PCIe Receive Data Input
PE3C_RX_DN[11:8] PE3C_RX_DP[11:8]	PCIe Receive Data Input
PE3D_RX_DN[15:12] PE3D_RX_DP[15:12]	PCIe Receive Data Input
PE3A_TX_DN[3:0] PE3A_TX_DP[3:0]	PCIe Transmit Data Output



Table 3-4. PCI Express\* Port 3 Signals (Sheet 2 of 2)

Signal Name	Description
PE3B_TX_DN[7:4] PE3B_TX_DP[7:4]	PCIe Transmit Data Output
PE3C_TX_DN[11:8] PE3C_TX_DP[11:8]	PCIe Transmit Data Output
PE3D_TX_DN[15:12] PE3D_TX_DP[15:12]	PCIe Transmit Data Output

Table 3-5. PCI Express\* Miscellaneous Signals

Signal Name	Description
PE_HP_SCL	PCI Express* Hot-Plug SMBus Clock: Provides PCI Express* hot-plug support via a dedicated SMBus interface. Requires an external general purpose input/output (GPIO) expansion device on the platform.
PE_HP_SDA	PCI Express* Hot-Plug SMBus Data: Provides PCI Express* hot-plug support via a dedicated SMBus interface. Requires an external general purpose input/output (GPIO) expansion device on the platform.

**Note:** Refer to the *Platform Design Guide* for additional implementation details.

### 3.3 DMI 2/PCI Express\* Port 0 Signals

Table 3-6. DMI 2 and PCI Express Port 0 Signals

Signal Name	Description
DMI_RX_DN[3:0] DMI_RX_DP[3:0]	DMI2 Receive Data Input
DMI_TX_DP[3:0] DMI_TX_DN[3:0]	DMI2 Transmit Data Output

### 3.4 Intel® QuickPath Interconnect Signals

Table 3-7. Intel® QPI Port Signals

Signal Name	Description
QPI1_CLKRX_DN/DP	Reference Clock Differential Input. These pins provide the PLL reference clock differential input. The Intel® QPI forward clock frequency is half the Intel® QPI data rate.
QPI1_CLKTX_DN/DP	Reference Clock Differential Output. These pins provide the PLL reference clock differential input. The Intel® QPI forward clock frequency is half the Intel® QPI data rate.
QPI1_DRX_DN/DP[19:0]	Intel® QPI Receive data input.
QPI1_DTX_DN/DP[19:0]	Intel® QPI Transmit data output.



## 3.5 PECE Signal

Table 3-8. PECE Signal

Signal Name	Description
PECE	PECE (Platform Environment Control Interface) is the serial sideband interface to the processor and is used primarily for thermal, power and error management. Details regarding the PECE electrical specifications, protocols and functions can be found in the Platform Environment Control Interface Specification.

## 3.6 System Reference Clock Signals

Table 3-9. System Reference Clock (BCLK) Signals

Signal Name	Description
BCLK{0/1}_D[N/P]	Reference Clock Differential input. These pins provide the PLL reference clock differential input into the processor. 100 MHz typical BCLK0 is the Intel® QPI reference clock (system clock) and BCLK1 is the PCI Express* reference clock.

## 3.7 JTAG and TAP Signals

Table 3-10. JTAG and TAP Signals

Signal Name	Description
BPM_N[7:0]	Breakpoint and Performance Monitor Signals: I/O signals from the processor that indicate the status of breakpoints and programmable counters used for monitoring processor performance. These are 100 MHz signals.
EAR_N	External Alignment of Reset, used to bring the processor up into a deterministic state. This signal is pulled up on the die, refer to <a href="#">Table 2-5</a> for details.
PRDY_N	Probe Mode Ready is a processor output used by debug tools to determine processor debug readiness.
PREQ_N	Probe Mode Request is used by debug tools to request debug operation of the processor.
TCK	TCK (Test Clock) provides the clock input for the processor Test Bus (also known as the Test Access Port).
TDI	TDI (Test Data In) transfers serial test data into the processor. TDI provides the serial input needed for JTAG specification support.
TDO	TDO (Test Data Out) transfers serial test data out of the processor. TDO provides the serial output needed for JTAG specification support.
TMS	TMS (Test Mode Select) is a JTAG specification support signal used by debug tools.
TRST_N	TRST_N (Test Reset) resets the Test Access Port (TAP) logic. TRST_N must be driven low during power-on reset.

**Note:** Refer to the *Platform Design Guide* for Debug Port implementation details.

## 3.8 Serial VID Interface (SVID) Signals

Table 3-11. SVID Signals (Sheet 1 of 2)

Signal Name	Description
SVIDALERT_N	Serial VID alert.



Table 3-11. SVID Signals (Sheet 2 of 2)

Signal Name	Description
SVIDCLK	Serial VID clock.
SVIDDATA	Serial VID data out.

### 3.9 Processor Asynchronous Sideband and Miscellaneous Signals

Table 3-12. Processor Asynchronous Sideband Signals (Sheet 1 of 3)

Signal Name	Description
BIST_ENABLE	BIST Enable Strap. Input which allows the platform to enable or disable built-in self test (BIST) on the processor. This signal is pulled up on the die, refer to <a href="#">Table 2-5</a> for details.
BMCINIT	BMC Initialization Strap. Indicates whether Service Processor Boot Mode should be used. Used in combination with FRMAGENT and SOCKET_ID inputs. <ul style="list-style-type: none"> <li>0: Service Processor Boot Mode Disabled. Example boot modes: Local PCH (this processor hosts a legacy PCH with firmware behind it), Intel® QPI Link Boot (for processors one hop away from the FW agent), or Intel® QPI Link Init (for processors more than one hop away from the firmware agent).</li> <li>1: Service Processor Boot Mode Enabled. In this mode of operation, the processor performs the absolute minimum internal configuration and then waits for the Service Processor to complete its initialization. The socket boots after receiving a "GO" handshake signal via a firmware scratchpad register.</li> </ul> This signal is pulled down on the die, refer to <a href="#">Table 2-5</a> for details.
CATERR_N	Indicates that the system has experienced a fatal or catastrophic error and cannot continue to operate. The processor will assert CATERR_N for nonrecoverable machine check errors and other internal unrecoverable errors. It is expected that every processor in the system will wire-OR CATERR_N for all processors. Since this is an I/O land, external agents are allowed to assert this land which will cause the processor to take a machine check exception. This signal is sampled after PWRGOOD assertion. <p>On the processor, CATERR_N is used for signaling the following types of errors:</p> <ul style="list-style-type: none"> <li>Legacy MCERR's, CATERR_N is asserted for 16 BCLKs.</li> <li>Legacy IERR's, CATERR_N remains asserted until warm or cold reset.</li> </ul>
DEBUG_EN_N	Forces debug to be enabled. This allows debug to occur beginning from cold boot.
ERROR_N[2:0]	Error status signals for integrated I/O (IIO) unit: <ul style="list-style-type: none"> <li>0 = Hardware correctable error (no operating system or firmware action necessary)</li> <li>1 = Non-fatal error (operating system or firmware action required to contain and recover)</li> <li>2 = Fatal error (system reset likely required to recover)</li> </ul>
FIVR_FAULT	Indicates an internal error has occurred with the integrated voltage regulator. The FIVR_FAULT signal can be sampled any time after 1.5 ms after the assertion of PWRGOOD. FIVR_FAULT must be qualified by THERMTRIP_N assertion. See the Platform Design Guide for proper connectivity.
FRMAGENT	Bootable Firmware Agent Strap. This input configuration strap used in combination with SOCKET_ID to determine whether the socket is a legacy socket, bootable firmware agent is present, and DMI links are used in PCIe* mode (instead of DMI2 mode). The firmware flash ROM is located behind the local PCH attached to the processor via the DMI2 interface. This signal is pulled down on the die, refer to <a href="#">Table 2-5</a> for details.

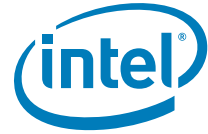


Table 3-12. Processor Asynchronous Sideband Signals (Sheet 2 of 3)

Signal Name	Description
MEM_HOT_C01_N MEM_HOT_C23_N	<p>Memory throttle control. MEM_HOT_C01_N and MEM_HOT_C23_N signals have two modes of operation – input and output mode.</p> <p>Input mode is externally asserted and is used to detect external events such as VR_HOT# from the memory voltage regulator and causes the processor to throttle the appropriate memory channels.</p> <p>Output mode is asserted by the processor known as level mode. In level mode, the output indicates that a particular branch of memory subsystem is hot.</p> <p>MEM_HOT_C01_N is used for memory channel 1 while MEM_HOT_C23_N is used for memory channels 2 &amp; 3.</p>
MSMI_N	Machine Check Exception (MCE) is signaled via this pin when eMCA2 is enabled.
PM_FAST_WAKE_N	Power Management Fast Wake. Enables quick package C3 - C6 exits of all sockets. Asserted if any socket detects a break from package C3 - C6 state requiring all sockets to exit the low power state to service a snoop, memory access, or interrupt. Expected to be wired-OR among all processor sockets within the platform.
PMSYNC	Power Management Sync. A sideband signal to communicate power management status from the Platform Controller Hub (PCH) to the processor.
PROCHOT_N	<p>PROCHOT_N will go active when the processor temperature monitoring sensor detects that the processor has reached its maximum safe operating temperature. This indicates that the processor Thermal Control Circuit has been activated, if enabled. This signal can also be driven to the processor to activate the Thermal Control Circuit. This signal is sampled after PWRGOOD assertion.</p> <p>If PROCHOT_N is asserted at the deassertion of RESET_N, the processor will tristate its outputs.</p>
PWRGOOD	<p>Power Good is a processor input. The processor requires this signal to be a clean indication that BCLK and power supplies are stable and within their specifications.</p> <p>“Clean” implies that the signal will remain low (capable of sinking leakage current), without glitches, from the time that the power supplies are turned on until they come within specification. The signal must then transition monotonically to a high state.</p> <p>PWRGOOD can be driven inactive at any time, but clocks and power must again be stable before a subsequent rising edge of PWRGOOD. PWRGOOD transitions from inactive to active when all supplies except V<sub>CCIN</sub> are stable. V<sub>CCIN</sub> has a V<sub>BOOT</sub> of 1.7 V volts and is included in PWRGOOD indication in this phase. However, for the active to inactive transition, if any CPU power supply is about to fail or is out of regulation, the PWRGOOD is to be negated.</p> <p>The signal must be supplied to the processor; it is used to protect internal circuits against voltage sequencing issues. It should be driven high throughout boundary scan operation.</p>
RESET_N	Asserting the RESET_N signal resets the processor to a known state and invalidates its internal caches without writing back any of their contents. Note some PLL, Intel® QuickPath Interconnect and error states are not affected by reset and only PWRGOOD forces them to a known state.
RSVD	RESERVED. All signals that are RSVD must be left unconnected on the board. Refer to <a href="#">Section 2.2.10, “Reserved or Unused Signals”</a> for details.
SAFE_MODE_BOOT	Safe mode boot Strap. SAFE_MODE_BOOT allows the processor to wake up safely by disabling all clock gating, this allows BIOS to load registers or patches if required. This signal is sampled after PWRGOOD assertion. The signal is pulled down on the die, refer to <a href="#">Table 2-5</a> for details.
SOCKET_ID[1:0]	Socket ID Strap. Socket identification configuration straps for establishing the PECL address, Intel® QPI Node ID, and other settings. This signal is used in combination with FRMAGENT to determine whether the socket is a legacy socket, bootable firmware agent is present, and DMI links are used in PCIe* mode (instead of DMI2 mode). Each processor socket consumes one Node ID, and there are 128 Home Agent tracker entries. This signal is pulled down on the die, refer to <a href="#">Table 2-5</a> for details.
TEST[4:0]	Test[4:0] must be individually connected to an appropriate power source or ground through a resistor for proper processor operation.





Table 3-12. Processor Asynchronous Sideband Signals (Sheet 3 of 3)

Signal Name	Description
THERMTRIP_N	Assertion of THERMTRIP_N (Thermal Trip) indicates one of two possible critical over-temperature conditions: One, the processor junction temperature has reached a level beyond which permanent silicon damage may occur and Two, the system memory interface has exceeded a critical temperature limit set by BIOS. Measurement of the processor junction temperature is accomplished through multiple internal thermal sensors that are monitored by the Digital Thermal Sensor (DTS). Simultaneously, the Power Control Unit (PCU) monitors external memory temperatures via the dedicated SMBus interface to the DIMMs. If any of the DIMMs exceed the BIOS defined limits, the PCU will signal THERMTRIP_N to prevent damage to the DIMMs. Once activated, the processor will stop all execution and shut down all PLLs. To further protect the processor, all power supply voltages must be removed following the assertion of THERMTRIP_N. Once activated, THERMTRIP_N remains latched until RESET_N is asserted. While the assertion of the RESET_N signal may de-assert THERMTRIP_N, if the processor's junction temperature remains at or above the trip level, THERMTRIP_N will again be asserted after RESET_N is de-asserted. This signal can also be asserted if the system memory interface has exceeded a critical temperature limit set by BIOS. This signal is sampled after PWRGOOD assertion.
TXT_AGENT	Intel® Trusted Execution Technology (Intel® TXT) Agent Strap. 0 = Default. The socket is not the Intel® TXT Agent. 1 = The socket is the Intel® TXT Agent. The legacy socket (identified by SOCKET_ID[1:0] = 00b) with Intel® TXT Agent should always set the TXT_AGENT to 1b. This signal is pulled down on the die, refer to Table 2-5 for details.
TXT_PLTEN	Intel® Trusted Execution Technology (Intel® TXT) Platform Enable Strap. 0 = The platform is not Intel® TXT enabled. All sockets should be set to zero. 1 = Default. The platform is Intel® TXT enabled. All sockets should be set to one. When this is set, Intel® TXT functionality requires user to explicitly enable Intel® TXT via BIOS setup. This signal is pulled up on the die, refer to Table 2-5 for details.

Table 3-13. Miscellaneous Signals

Signal Name	Description
PROC_ID_N	This output can be used by the platform to distinguish between Intel® Xeon® Processor E5-2400 v3 Product Family or a potential future product family. There is no connection either to the silicon or package substrate.
SKTOCC_N	SKTOCC_N (Socket occupied) is used to indicate that a processor is present. This is pulled to ground on the processor package; there is no connection to the processor silicon for this signal.
DBR_N	These signals are pass-through pins with no connection to processor silicon for use with Top Side Probe only. Signals pass from the system board through package substrate to connector pins on the top side of the processor package. Top Side Probe implementation is found in the <i>Platform Design Guide</i> .
ITP_BCLK_D[N/P]	
JTAG_TDOX	
SYS_PWROK	

## 3.10 Processor Power and Ground Supplies

Table 3-14. Power and Ground Signals (Sheet 1 of 2)

Signal Name	Description
V <sub>CCIN</sub>	Power supply input for the Integrated Voltage Regulators the deliver power to processor cores, lowest level caches, ring interface, and home agent. The output voltage of this supply is selected by the processor, using the serial voltage identification (SVID) interface.

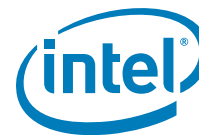


Table 3-14. Power and Ground Signals (Sheet 2 of 2)

Signal Name	Description
V <sub>CCIN_SENSE</sub> V <sub>SS_VCCIN_SENSE</sub>	Isolated, low impedance connection to the processor power and ground. These signals must be connected to the voltage regulator feedback circuit, which ensures processor voltage remains within specification.
V <sub>CCIO_IN</sub>	Power supply for miscellaneous I/O interfaces of the processor.
V <sub>CCPECI</sub>	Power supply for Peci interface of the processor.
V <sub>CCD</sub>	Variable power supply for the processor system memory interface. Provided by one regulator per CPU socket for all memory channels. The valid nominal voltage of this supply (1.50V or 1.35V) is configured by BIOS after determining the operating voltages of the installed memory.  <b>Note:</b> The processor must be provided V <sub>CCD</sub> for proper operation, even in configurations where no memory is populated.
V <sub>SS</sub>	Processor ground node.

§



# 4 Processor Land Listing

## 4.1 Land Listing by Name

**Note:** This land listing is provided in this document for convenience.

**Table 4-1. Land Listing (Sheet 1 of 37)**

Land Name	Land Number	Buffer Type	Direction
BCLK0_DN	AN13	CMOS	I
BCLK0_DP	AP13	CMOS	I
BCLK1_DN	AM30	CMOS	I
BCLK1_DP	AN30	CMOS	I
BIST_ENABLE	AM6	CMOS	I
BMCINIT	AF1	CMOS	I
BPM_N[0]	AL10	ODCMOS	I/O
BPM_N[1]	AK15	ODCMOS	I/O
BPM_N[2]	AR11	ODCMOS	I/O
BPM_N[3]	AN11	ODCMOS	I/O
BPM_N[4]	AP10	ODCMOS	I/O
BPM_N[5]	AP11	ODCMOS	I/O
BPM_N[6]	AN10	ODCMOS	I/O
BPM_N[7]	AP12	ODCMOS	I/O
CATERR_N	AT6	ODCMOS	I/O
DBR_N	AE36		
DDR_RESET_C01_N	L26	CMOS	O
DDR_RESET_C23_N	D27	CMOS	O
DDR_SCL_C01	W7	ODCMOS	I/O
DDR_SCL_C23	V40	ODCMOS	I/O
DDR_SDA_C01	W6	ODCMOS	I/O
DDR_SDA_C23	V37	ODCMOS	I/O
DDR01_RCOMP[0]	P10	ANALOG	I
DDR01_RCOMP[1]	N10	ANALOG	I
DDR01_RCOMP[2]	W10	ANALOG	I
DDR01_VREF	M7	DC	O
DDR01_VREFDQ[1]	W4	DC	O
DDR1_BA[0]	H16	SSTL	O
DDR1_BA[1]	J16	SSTL	O
DDR1_BA[2]	J22	SSTL	O
DDR1_CAS_N	L13	SSTL	O

**Table 4-1. Land Listing (Sheet 2 of 37)**

Land Name	Land Number	Buffer Type	Direction
DDR1_CKE[0]	J25	SSTL	O
DDR1_CKE[1]	J26	SSTL	O
DDR1_CKE[2]	K24	SSTL	O
DDR1_CKE[3]	H26	SSTL	O
DDR1_CLK_DN[0]	J17	SSTL	O
DDR1_CLK_DN[1]	G19	SSTL	O
DDR1_CLK_DN[2]	L16	SSTL	O
DDR1_CLK_DN[3]	H18	SSTL	O
DDR1_CLK_DP[0]	K17	SSTL	O
DDR1_CLK_DP[1]	H19	SSTL	O
DDR1_CLK_DP[2]	L17	SSTL	O
DDR1_CLK_DP[3]	J18	SSTL	O
DDR1_CS_N[0]	K15	SSTL	O
DDR1_CS_N[1]	L15	SSTL	O
DDR1_CS_N[2]	L11	SSTL	O
DDR1_CS_N[3]	K11	SSTL	O
DDR1_CS_N[4]	J15	SSTL	O
DDR1_CS_N[5]	L14	SSTL	O
DDR1_CS_N[6]	L12	SSTL	O
DDR1_CS_N[7]	K12	SSTL	O
DDR1_DQ[0]	AC34	SSTL	I/O
DDR1_DQ[1]	AC35	SSTL	I/O
DDR1_DQ[10]	M35	SSTL	I/O
DDR1_DQ[11]	M36	SSTL	I/O
DDR1_DQ[12]	U35	SSTL	I/O
DDR1_DQ[13]	U36	SSTL	I/O
DDR1_DQ[14]	N35	SSTL	I/O
DDR1_DQ[15]	N36	SSTL	I/O
DDR1_DQ[16]	J36	SSTL	I/O
DDR1_DQ[17]	J35	SSTL	I/O
DDR1_DQ[18]	E35	SSTL	I/O

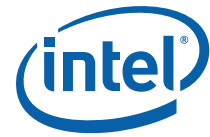


Table 4-1. Land Listing (Sheet 3 of 37)

Land Name	Land Number	Buffer Type	Direction
DDR1_DQ[19]	F35	SSTL	I/O
DDR1_DQ[2]	W35	SSTL	I/O
DDR1_DQ[20]	K36	SSTL	I/O
DDR1_DQ[21]	K35	SSTL	I/O
DDR1_DQ[22]	E36	SSTL	I/O
DDR1_DQ[23]	F36	SSTL	I/O
DDR1_DQ[24]	L32	SSTL	I/O
DDR1_DQ[25]	K32	SSTL	I/O
DDR1_DQ[26]	L28	SSTL	I/O
DDR1_DQ[27]	K28	SSTL	I/O
DDR1_DQ[28]	K33	SSTL	I/O
DDR1_DQ[29]	L33	SSTL	I/O
DDR1_DQ[3]	W36	SSTL	I/O
DDR1_DQ[30]	L29	SSTL	I/O
DDR1_DQ[31]	K29	SSTL	I/O
DDR1_DQ[32]	K9	SSTL	I/O
DDR1_DQ[33]	L9	SSTL	I/O
DDR1_DQ[34]	K5	SSTL	I/O
DDR1_DQ[35]	L5	SSTL	I/O
DDR1_DQ[36]	K10	SSTL	I/O
DDR1_DQ[37]	L10	SSTL	I/O
DDR1_DQ[38]	K6	SSTL	I/O
DDR1_DQ[39]	L6	SSTL	I/O
DDR1_DQ[4]	AD34	SSTL	I/O
DDR1_DQ[40]	N8	SSTL	I/O
DDR1_DQ[41]	P8	SSTL	I/O
DDR1_DQ[42]	V9	SSTL	I/O
DDR1_DQ[43]	V8	SSTL	I/O
DDR1_DQ[44]	N9	SSTL	I/O
DDR1_DQ[45]	P9	SSTL	I/O
DDR1_DQ[46]	U9	SSTL	I/O
DDR1_DQ[47]	U8	SSTL	I/O
DDR1_DQ[48]	AA9	SSTL	I/O
DDR1_DQ[49]	AA8	SSTL	I/O
DDR1_DQ[5]	AD35	SSTL	I/O
DDR1_DQ[50]	AE9	SSTL	I/O
DDR1_DQ[51]	AE8	SSTL	I/O

Table 4-1. Land Listing (Sheet 4 of 37)

Land Name	Land Number	Buffer Type	Direction
DDR1_DQ[52]	Y9	SSTL	I/O
DDR1_DQ[53]	Y8	SSTL	I/O
DDR1_DQ[54]	AD9	SSTL	I/O
DDR1_DQ[55]	AD8	SSTL	I/O
DDR1_DQ[56]	Y1	SSTL	I/O
DDR1_DQ[57]	AA3	SSTL	I/O
DDR1_DQ[58]	AE1	SSTL	I/O
DDR1_DQ[59]	AE2	SSTL	I/O
DDR1_DQ[6]	Y35	SSTL	I/O
DDR1_DQ[60]	Y3	SSTL	I/O
DDR1_DQ[61]	Y2	SSTL	I/O
DDR1_DQ[62]	AD2	SSTL	I/O
DDR1_DQ[63]	AD3	SSTL	I/O
DDR1_DQ[7]	Y36	SSTL	I/O
DDR1_DQ[8]	T35	SSTL	I/O
DDR1_DQ[9]	T36	SSTL	I/O
DDR1_DQS_N[0]	AA35	SSTL	I/O
DDR1_DQS_N[1]	P35	SSTL	I/O
DDR1_DQS_N[10]	R36	SSTL	I/O
DDR1_DQS_N[11]	H35	SSTL	I/O
DDR1_DQS_N[12]	K31	SSTL	I/O
DDR1_DQS_N[13]	L8	SSTL	I/O
DDR1_DQS_N[14]	R8	SSTL	I/O
DDR1_DQS_N[15]	AB8	SSTL	I/O
DDR1_DQS_N[16]	AC3	SSTL	I/O
DDR1_DQS_N[17]	G31	SSTL	I/O
DDR1_DQS_N[2]	G36	SSTL	I/O
DDR1_DQS_N[3]	L30	SSTL	I/O
DDR1_DQS_N[4]	K7	SSTL	I/O
DDR1_DQS_N[5]	T9	SSTL	I/O
DDR1_DQS_N[6]	AC9	SSTL	I/O
DDR1_DQS_N[7]	AC2	SSTL	I/O
DDR1_DQS_N[8]	H30	SSTL	I/O
DDR1_DQS_N[9]	AB35	SSTL	I/O
DDR1_DQS_P[0]	AA36	SSTL	I/O
DDR1_DQS_P[1]	P36	SSTL	I/O
DDR1_DQS_P[10]	R35	SSTL	I/O



Table 4-1. Land Listing (Sheet 5 of 37)

Land Name	Land Number	Buffer Type	Direction
DDR1_DQS_P[11]	H36	SSTL	I/O
DDR1_DQS_P[12]	L31	SSTL	I/O
DDR1_DQS_P[13]	K8	SSTL	I/O
DDR1_DQS_P[14]	R9	SSTL	I/O
DDR1_DQS_P[15]	AB9	SSTL	I/O
DDR1_DQS_P[16]	AB3	SSTL	I/O
DDR1_DQS_P[17]	H31	SSTL	I/O
DDR1_DQS_P[2]	G35	SSTL	I/O
DDR1_DQS_P[3]	K30	SSTL	I/O
DDR1_DQS_P[4]	L7	SSTL	I/O
DDR1_DQS_P[5]	T8	SSTL	I/O
DDR1_DQS_P[6]	AC8	SSTL	I/O
DDR1_DQS_P[7]	AC1	SSTL	I/O
DDR1_DQS_P[8]	G30	SSTL	I/O
DDR1_DQS_P[9]	AB34	SSTL	I/O
DDR1_ECC[0]	H32	SSTL	I/O
DDR1_ECC[1]	G32	SSTL	I/O
DDR1_ECC[2]	H28	SSTL	I/O
DDR1_ECC[3]	G28	SSTL	I/O
DDR1_ECC[4]	G33	SSTL	I/O
DDR1_ECC[5]	H33	SSTL	I/O
DDR1_ECC[6]	H29	SSTL	I/O
DDR1_ECC[7]	G29	SSTL	I/O
DDR1_MA[0]	K19	SSTL	O
DDR1_MA[1]	L20	SSTL	O
DDR1_MA[10]	L18	SSTL	O
DDR1_MA[11]	K26	SSTL	O
DDR1_MA[12]	J20	SSTL	O
DDR1_MA[13]	H13	SSTL	O
DDR1_MA[14]	K20	SSTL	O
DDR1_MA[15]	J24	SSTL	O
DDR1_MA[2]	L19	SSTL	O
DDR1_MA[3]	L21	SSTL	O
DDR1_MA[4]	K22	SSTL	O
DDR1_MA[5]	L22	SSTL	O
DDR1_MA[6]	L24	SSTL	O
DDR1_MA[7]	L25	SSTL	O

Table 4-1. Land Listing (Sheet 6 of 37)

Land Name	Land Number	Buffer Type	Direction
DDR1_MA[8]	L23	SSTL	O
DDR1_MA[9]	L27	SSTL	O
DDR1_ODT[0]	G15	SSTL	O
DDR1_ODT[1]	G13	SSTL	O
DDR1_ODT[2]	J14	SSTL	O
DDR1_ODT[3]	J12	SSTL	O
DDR1_PAR	J19	SSTL	O
DDR1_PAR_ERR_N	J21	SSTL	I
DDR1_RAS_N	K14	SSTL	O
DDR1_WE_N	K13	SSTL	O
DDR2_BA[0]	H17	SSTL	O
DDR2_BA[1]	E17	SSTL	O
DDR2_BA[2]	G26	SSTL	O
DDR2_CAS_N	H14	SSTL	O
DDR2_CKE[0]	J27	SSTL	O
DDR2_CKE[1]	G27	SSTL	O
DDR2_CKE[2]	E27	SSTL	O
DDR2_CKE[3]	H27	SSTL	O
DDR2_CLK_DN[0]	E19	SSTL	O
DDR2_CLK_DN[1]	H21	SSTL	O
DDR2_CLK_DN[2]	G20	SSTL	O
DDR2_CLK_DN[3]	F21	SSTL	O
DDR2_CLK_DP[0]	E20	SSTL	O
DDR2_CLK_DP[1]	G21	SSTL	O
DDR2_CLK_DP[2]	F20	SSTL	O
DDR2_CLK_DP[3]	F22	SSTL	O
DDR2_CS_N[0]	G16	SSTL	O
DDR2_CS_N[1]	G14	SSTL	O
DDR2_CS_N[2]	F11	SSTL	O
DDR2_CS_N[3]	G12	SSTL	O
DDR2_CS_N[4]	E15	SSTL	O
DDR2_CS_N[5]	E14	SSTL	O
DDR2_CS_N[6]	G11	SSTL	O
DDR2_CS_N[7]	H11	SSTL	O
DDR2_DQ[0]	AC39	SSTL	I/O
DDR2_DQ[1]	AC38	SSTL	I/O
DDR2_DQ[10]	M38	SSTL	I/O

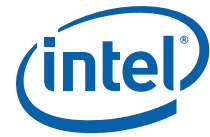


Table 4-1. Land Listing (Sheet 7 of 37)

Land Name	Land Number	Buffer Type	Direction
DDR2_DQ[11]	M39	SSTL	I/O
DDR2_DQ[12]	U39	SSTL	I/O
DDR2_DQ[13]	U38	SSTL	I/O
DDR2_DQ[14]	N39	SSTL	I/O
DDR2_DQ[15]	N38	SSTL	I/O
DDR2_DQ[16]	J38	SSTL	I/O
DDR2_DQ[17]	J39	SSTL	I/O
DDR2_DQ[18]	E39	SSTL	I/O
DDR2_DQ[19]	E38	SSTL	I/O
DDR2_DQ[2]	W39	SSTL	I/O
DDR2_DQ[20]	K38	SSTL	I/O
DDR2_DQ[21]	K39	SSTL	I/O
DDR2_DQ[22]	F39	SSTL	I/O
DDR2_DQ[23]	F38	SSTL	I/O
DDR2_DQ[24]	B39	SSTL	I/O
DDR2_DQ[25]	A39	SSTL	I/O
DDR2_DQ[26]	C34	SSTL	I/O
DDR2_DQ[27]	B34	SSTL	I/O
DDR2_DQ[28]	C38	SSTL	I/O
DDR2_DQ[29]	C39	SSTL	I/O
DDR2_DQ[3]	W38	SSTL	I/O
DDR2_DQ[30]	C35	SSTL	I/O
DDR2_DQ[31]	B35	SSTL	I/O
DDR2_DQ[32]	D9	SSTL	I/O
DDR2_DQ[33]	E9	SSTL	I/O
DDR2_DQ[34]	E5	SSTL	I/O
DDR2_DQ[35]	D5	SSTL	I/O
DDR2_DQ[36]	D10	SSTL	I/O
DDR2_DQ[37]	E10	SSTL	I/O
DDR2_DQ[38]	D6	SSTL	I/O
DDR2_DQ[39]	E6	SSTL	I/O
DDR2_DQ[4]	AD37	SSTL	I/O
DDR2_DQ[40]	G9	SSTL	I/O
DDR2_DQ[41]	H9	SSTL	I/O
DDR2_DQ[42]	G5	SSTL	I/O
DDR2_DQ[43]	H5	SSTL	I/O
DDR2_DQ[44]	G10	SSTL	I/O

Table 4-1. Land Listing (Sheet 8 of 37)

Land Name	Land Number	Buffer Type	Direction
DDR2_DQ[45]	H10	SSTL	I/O
DDR2_DQ[46]	G6	SSTL	I/O
DDR2_DQ[47]	H6	SSTL	I/O
DDR2_DQ[48]	P6	SSTL	I/O
DDR2_DQ[49]	P5	SSTL	I/O
DDR2_DQ[5]	AC37	SSTL	I/O
DDR2_DQ[50]	V6	SSTL	I/O
DDR2_DQ[51]	V5	SSTL	I/O
DDR2_DQ[52]	N6	SSTL	I/O
DDR2_DQ[53]	N5	SSTL	I/O
DDR2_DQ[54]	U6	SSTL	I/O
DDR2_DQ[55]	U5	SSTL	I/O
DDR2_DQ[56]	AA6	SSTL	I/O
DDR2_DQ[57]	AA5	SSTL	I/O
DDR2_DQ[58]	AE6	SSTL	I/O
DDR2_DQ[59]	AE5	SSTL	I/O
DDR2_DQ[6]	Y39	SSTL	I/O
DDR2_DQ[60]	Y6	SSTL	I/O
DDR2_DQ[61]	Y5	SSTL	I/O
DDR2_DQ[62]	AD6	SSTL	I/O
DDR2_DQ[63]	AD5	SSTL	I/O
DDR2_DQ[7]	Y38	SSTL	I/O
DDR2_DQ[8]	T39	SSTL	I/O
DDR2_DQ[9]	T38	SSTL	I/O
DDR2_DQS_N[0]	AA39	SSTL	I/O
DDR2_DQS_N[1]	P39	SSTL	I/O
DDR2_DQS_N[10]	R38	SSTL	I/O
DDR2_DQS_N[11]	H38	SSTL	I/O
DDR2_DQS_N[12]	B37	SSTL	I/O
DDR2_DQS_N[13]	E8	SSTL	I/O
DDR2_DQS_N[14]	H8	SSTL	I/O
DDR2_DQS_N[15]	R5	SSTL	I/O
DDR2_DQS_N[16]	AB5	SSTL	I/O
DDR2_DQS_N[17]	D31	SSTL	I/O
DDR2_DQS_N[2]	G39	SSTL	I/O
DDR2_DQS_N[3]	C36	SSTL	I/O
DDR2_DQS_N[4]	D7	SSTL	I/O



Table 4-1. Land Listing (Sheet 9 of 37)

Land Name	Land Number	Buffer Type	Direction
DDR2_DQS_N[5]	G7	SSTL	I/O
DDR2_DQS_N[6]	T6	SSTL	I/O
DDR2_DQS_N[7]	AC6	SSTL	I/O
DDR2_DQS_N[8]	E30	SSTL	I/O
DDR2_DQS_N[9]	AB38	SSTL	I/O
DDR2_DQS_P[0]	AA38	SSTL	I/O
DDR2_DQS_P[1]	P38	SSTL	I/O
DDR2_DQS_P[10]	R39	SSTL	I/O
DDR2_DQS_P[11]	H39	SSTL	I/O
DDR2_DQS_P[12]	C37	SSTL	I/O
DDR2_DQS_P[13]	D8	SSTL	I/O
DDR2_DQS_P[14]	G8	SSTL	I/O
DDR2_DQS_P[15]	R6	SSTL	I/O
DDR2_DQS_P[16]	AB6	SSTL	I/O
DDR2_DQS_P[17]	E31	SSTL	I/O
DDR2_DQS_P[2]	G38	SSTL	I/O
DDR2_DQS_P[3]	B36	SSTL	I/O
DDR2_DQS_P[4]	E7	SSTL	I/O
DDR2_DQS_P[5]	H7	SSTL	I/O
DDR2_DQS_P[6]	T5	SSTL	I/O
DDR2_DQS_P[7]	AC5	SSTL	I/O
DDR2_DQS_P[8]	D30	SSTL	I/O
DDR2_DQS_P[9]	AB39	SSTL	I/O
DDR2_ECC[0]	E32	SSTL	I/O
DDR2_ECC[1]	D32	SSTL	I/O
DDR2_ECC[2]	E28	SSTL	I/O
DDR2_ECC[3]	D28	SSTL	I/O
DDR2_ECC[4]	D33	SSTL	I/O
DDR2_ECC[5]	E33	SSTL	I/O
DDR2_ECC[6]	E29	SSTL	I/O
DDR2_ECC[7]	D29	SSTL	I/O
DDR2_MA[0]	E18	SSTL	O
DDR2_MA[1]	E22	SSTL	O
DDR2_MA[10]	G18	SSTL	O
DDR2_MA[11]	F25	SSTL	O
DDR2_MA[12]	E25	SSTL	O
DDR2_MA[13]	E13	SSTL	O

Table 4-1. Land Listing (Sheet 10 of 37)

Land Name	Land Number	Buffer Type	Direction
DDR2_MA[14]	H25	SSTL	O
DDR2_MA[15]	E26	SSTL	O
DDR2_MA[2]	H22	SSTL	O
DDR2_MA[3]	G23	SSTL	O
DDR2_MA[4]	H23	SSTL	O
DDR2_MA[5]	F23	SSTL	O
DDR2_MA[6]	J23	SSTL	O
DDR2_MA[7]	G24	SSTL	O
DDR2_MA[8]	E24	SSTL	O
DDR2_MA[9]	H24	SSTL	O
DDR2_ODT[0]	F16	SSTL	O
DDR2_ODT[1]	F13	SSTL	O
DDR2_ODT[2]	H12	SSTL	O
DDR2_ODT[3]	E12	SSTL	O
DDR2_PAR	F18	SSTL	O
DDR2_PAR_ERR_N	G25	SSTL	I
DDR2_RAS_N	F17	SSTL	O
DDR2_WE_N	F15	SSTL	O
DDR23_RCOMP[0]	N34	ANALOG	I
DDR23_RCOMP[1]	L37	ANALOG	I
DDR23_RCOMP[2]	D37	ANALOG	I
DDR23_VREF	D40	DC	O
DDR23_VREFDQ[0]	D34	DC	O
DDR23_VREFDQ[1]	L34	DC	O
DDR3_BA[0]	A16	SSTL	O
DDR3_BA[1]	B16	SSTL	O
DDR3_BA[2]	B25	SSTL	O
DDR3_CAS_N	D15	SSTL	O
DDR3_CKE[0]	B26	SSTL	O
DDR3_CKE[1]	C26	SSTL	O
DDR3_CKE[2]	D26	SSTL	O
DDR3_CKE[3]	A26	SSTL	O
DDR3_CLK_DN[0]	C18	SSTL	O
DDR3_CLK_DN[1]	A19	SSTL	O
DDR3_CLK_DN[2]	B18	SSTL	O
DDR3_CLK_DN[3]	B20	SSTL	O
DDR3_CLK_DP[0]	C19	SSTL	O

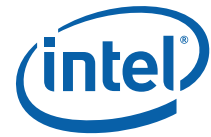


Table 4-1. Land Listing (Sheet 11 of 37)

Land Name	Land Number	Buffer Type	Direction
DDR3_CLK_DP[1]	B19	SSTL	O
DDR3_CLK_DP[2]	A18	SSTL	O
DDR3_CLK_DP[3]	A20	SSTL	O
DDR3_CS_N[0]	A15	SSTL	O
DDR3_CS_N[1]	B13	SSTL	O
DDR3_CS_N[2]	B11	SSTL	O
DDR3_CS_N[3]	D11	SSTL	O
DDR3_CS_N[4]	B15	SSTL	O
DDR3_CS_N[5]	B14	SSTL	O
DDR3_CS_N[6]	C11	SSTL	O
DDR3_CS_N[7]	D12	SSTL	O
DDR3_DQ[0]	AC41	SSTL	I/O
DDR3_DQ[1]	AC42	SSTL	I/O
DDR3_DQ[10]	P41	SSTL	I/O
DDR3_DQ[11]	N43	SSTL	I/O
DDR3_DQ[12]	U41	SSTL	I/O
DDR3_DQ[13]	U43	SSTL	I/O
DDR3_DQ[14]	P43	SSTL	I/O
DDR3_DQ[15]	P42	SSTL	I/O
DDR3_DQ[16]	L43	SSTL	I/O
DDR3_DQ[17]	L42	SSTL	I/O
DDR3_DQ[18]	H43	SSTL	I/O
DDR3_DQ[19]	H41	SSTL	I/O
DDR3_DQ[2]	W42	SSTL	I/O
DDR3_DQ[20]	M41	SSTL	I/O
DDR3_DQ[21]	L41	SSTL	I/O
DDR3_DQ[22]	J43	SSTL	I/O
DDR3_DQ[23]	H42	SSTL	I/O
DDR3_DQ[24]	F41	SSTL	I/O
DDR3_DQ[25]	E41	SSTL	I/O
DDR3_DQ[26]	C41	SSTL	I/O
DDR3_DQ[27]	B41	SSTL	I/O
DDR3_DQ[28]	F42	SSTL	I/O
DDR3_DQ[29]	F43	SSTL	I/O
DDR3_DQ[3]	W43	SSTL	I/O
DDR3_DQ[30]	C42	SSTL	I/O
DDR3_DQ[31]	D41	SSTL	I/O

Table 4-1. Land Listing (Sheet 12 of 37)

Land Name	Land Number	Buffer Type	Direction
DDR3_DQ[32]	A9	SSTL	I/O
DDR3_DQ[33]	B9	SSTL	I/O
DDR3_DQ[34]	B5	SSTL	I/O
DDR3_DQ[35]	B4	SSTL	I/O
DDR3_DQ[36]	A10	SSTL	I/O
DDR3_DQ[37]	B10	SSTL	I/O
DDR3_DQ[38]	A6	SSTL	I/O
DDR3_DQ[39]	B6	SSTL	I/O
DDR3_DQ[4]	AD42	SSTL	I/O
DDR3_DQ[40]	E3	SSTL	I/O
DDR3_DQ[41]	D2	SSTL	I/O
DDR3_DQ[42]	G1	SSTL	I/O
DDR3_DQ[43]	G2	SSTL	I/O
DDR3_DQ[44]	C3	SSTL	I/O
DDR3_DQ[45]	D3	SSTL	I/O
DDR3_DQ[46]	F3	SSTL	I/O
DDR3_DQ[47]	G3	SSTL	I/O
DDR3_DQ[48]	J2	SSTL	I/O
DDR3_DQ[49]	K1	SSTL	I/O
DDR3_DQ[5]	AD43	SSTL	I/O
DDR3_DQ[50]	M3	SSTL	I/O
DDR3_DQ[51]	N3	SSTL	I/O
DDR3_DQ[52]	J3	SSTL	I/O
DDR3_DQ[53]	J1	SSTL	I/O
DDR3_DQ[54]	M2	SSTL	I/O
DDR3_DQ[55]	M1	SSTL	I/O
DDR3_DQ[56]	R2	SSTL	I/O
DDR3_DQ[57]	R1	SSTL	I/O
DDR3_DQ[58]	V1	SSTL	I/O
DDR3_DQ[59]	V3	SSTL	I/O
DDR3_DQ[6]	Y41	SSTL	I/O
DDR3_DQ[60]	P1	SSTL	I/O
DDR3_DQ[61]	R3	SSTL	I/O
DDR3_DQ[62]	U1	SSTL	I/O
DDR3_DQ[63]	V2	SSTL	I/O
DDR3_DQ[7]	W41	SSTL	I/O
DDR3_DQ[8]	U42	SSTL	I/O





Table 4-1. Land Listing (Sheet 13 of 37)

Land Name	Land Number	Buffer Type	Direction
DDR3_DQ[9]	T43	SSTL	I/O
DDR3_DQS_N[0]	AB41	SSTL	I/O
DDR3_DQS_N[1]	R43	SSTL	I/O
DDR3_DQS_N[10]	R41	SSTL	I/O
DDR3_DQS_N[11]	K43	SSTL	I/O
DDR3_DQS_N[12]	E42	SSTL	I/O
DDR3_DQS_N[13]	B8	SSTL	I/O
DDR3_DQS_N[14]	E1	SSTL	I/O
DDR3_DQS_N[15]	L3	SSTL	I/O
DDR3_DQS_N[16]	T1	SSTL	I/O
DDR3_DQS_N[17]	A30	SSTL	I/O
DDR3_DQS_N[2]	K41	SSTL	I/O
DDR3_DQS_N[3]	D43	SSTL	I/O
DDR3_DQS_N[4]	A7	SSTL	I/O
DDR3_DQS_N[5]	F2	SSTL	I/O
DDR3_DQS_N[6]	L1	SSTL	I/O
DDR3_DQS_N[7]	T3	SSTL	I/O
DDR3_DQS_N[8]	B29	SSTL	I/O
DDR3_DQS_N[9]	AB43	SSTL	I/O
DDR3_DQS_P[0]	AA41	SSTL	I/O
DDR3_DQS_P[1]	R42	SSTL	I/O
DDR3_DQS_P[10]	T41	SSTL	I/O
DDR3_DQS_P[11]	K42	SSTL	I/O
DDR3_DQS_P[12]	E43	SSTL	I/O
DDR3_DQS_P[13]	A8	SSTL	I/O
DDR3_DQS_P[14]	E2	SSTL	I/O
DDR3_DQS_P[15]	K3	SSTL	I/O
DDR3_DQS_P[16]	T2	SSTL	I/O
DDR3_DQS_P[17]	B30	SSTL	I/O
DDR3_DQS_P[2]	J41	SSTL	I/O
DDR3_DQS_P[3]	D42	SSTL	I/O
DDR3_DQS_P[4]	B7	SSTL	I/O
DDR3_DQS_P[5]	F1	SSTL	I/O
DDR3_DQS_P[6]	L2	SSTL	I/O
DDR3_DQS_P[7]	U3	SSTL	I/O
DDR3_DQS_P[8]	A29	SSTL	I/O
DDR3_DQS_P[9]	AB42	SSTL	I/O

Table 4-1. Land Listing (Sheet 14 of 37)

Land Name	Land Number	Buffer Type	Direction
DDR3_ECC[0]	A31	SSTL	I/O
DDR3_ECC[1]	A32	SSTL	I/O
DDR3_ECC[2]	B27	SSTL	I/O
DDR3_ECC[3]	A27	SSTL	I/O
DDR3_ECC[4]	B32	SSTL	I/O
DDR3_ECC[5]	B31	SSTL	I/O
DDR3_ECC[6]	B28	SSTL	I/O
DDR3_ECC[7]	A28	SSTL	I/O
DDR3_MA[0]	A17	SSTL	O
DDR3_MA[1]	D19	SSTL	O
DDR3_MA[10]	D17	SSTL	O
DDR3_MA[11]	C24	SSTL	O
DDR3_MA[12]	B24	SSTL	O
DDR3_MA[13]	D14	SSTL	O
DDR3_MA[14]	D25	SSTL	O
DDR3_MA[15]	A25	SSTL	O
DDR3_MA[2]	D20	SSTL	O
DDR3_MA[3]	C21	SSTL	O
DDR3_MA[4]	D21	SSTL	O
DDR3_MA[5]	C22	SSTL	O
DDR3_MA[6]	D22	SSTL	O
DDR3_MA[7]	C23	SSTL	O
DDR3_MA[8]	D23	SSTL	O
DDR3_MA[9]	D24	SSTL	O
DDR3_ODT[0]	A14	SSTL	O
DDR3_ODT[1]	C12	SSTL	O
DDR3_ODT[2]	C14	SSTL	O
DDR3_ODT[3]	C13	SSTL	O
DDR3_PAR	C17	SSTL	O
DDR3_PAR_ERR_N	A24	SSTL	I
DDR3_RAS_N	C16	SSTL	O
DDR3_WE_N	D16	SSTL	O
DEBUG_EN_N	AM3	CMOS	I
DMI_RX_DN[0]	AM33	PCIEX	I
DMI_RX_DN[1]	AL34	PCIEX	I
DMI_RX_DN[2]	AH35	PCIEX	I
DMI_RX_DN[3]	AF35	PCIEX	I

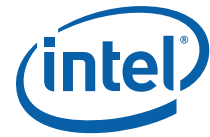


Table 4-1. Land Listing (Sheet 15 of 37)

Land Name	Land Number	Buffer Type	Direction
DMI_RX_DP[0]	AM32	PCIEX	I
DMI_RX_DP[1]	AL33	PCIEX	I
DMI_RX_DP[2]	AH34	PCIEX	I
DMI_RX_DP[3]	AF34	PCIEX	I
DMI_TX_DN[0]	AM35	PCIEX	O
DMI_TX_DN[1]	AL36	PCIEX	O
DMI_TX_DN[2]	AK35	PCIEX	O
DMI_TX_DN[3]	AJ36	PCIEX	O
DMI_TX_DP[0]	AM36	PCIEX	O
DMI_TX_DP[1]	AL37	PCIEX	O
DMI_TX_DP[2]	AK36	PCIEX	O
DMI_TX_DP[3]	AJ37	PCIEX	O
DRAM_PWR_OK_C01	Y10	CMOS	I
DRAM_PWR_OK_C23	AD40	CMOS	I
EAR_N	AH3	CMOS	I
ERROR_N[0]	AK34	Open Drain	O
ERROR_N[1]	AJ34	Open Drain	O
ERROR_N[2]	BA38	Open Drain	O
FIVR_FAULT	AV15	CMOS	O
FRMAGENT	AF2	CMOS	I
ITP_BCLK_DN	AL11		
ITP_BCLK_DP	AK11		
JTAG_TDOX	AE43		
MEM_HOT_C01_N	V10	Open Drain	I/O
MEM_HOT_C23_N	M42	Open Drain	I/O
MSMI_N	P4	Open Drain	I/O
PE_HP_SCL	AR30	ODCMOS	I/O
PE_HP_SDA	AR29	ODCMOS	I/O
PE1A_RX_DN[0]	AE40	PCIEX	I
PE1A_RX_DN[1]	AG37	PCIEX	I
PE1A_RX_DN[2]	AF38	PCIEX	I
PE1A_RX_DN[3]	AG39	PCIEX	I
PE1A_RX_DP[0]	AE39	PCIEX	I
PE1A_RX_DP[1]	AG36	PCIEX	I
PE1A_RX_DP[2]	AF39	PCIEX	I
PE1A_RX_DP[3]	AG40	PCIEX	I
PE1A_TX_DN[0]	AW41	PCIEX	O

Table 4-1. Land Listing (Sheet 16 of 37)

Land Name	Land Number	Buffer Type	Direction
PE1A_TX_DN[1]	AV39	PCIEX	O
PE1A_TX_DN[2]	AU38	PCIEX	O
PE1A_TX_DN[3]	AT37	PCIEX	O
PE1A_TX_DP[0]	AV41	PCIEX	O
PE1A_TX_DP[1]	AU39	PCIEX	O
PE1A_TX_DP[2]	AT38	PCIEX	O
PE1A_TX_DP[3]	AR37	PCIEX	O
PE1B_RX_DN[4]	AF41	PCIEX	I
PE1B_RX_DN[5]	AG42	PCIEX	I
PE1B_RX_DN[6]	AH41	PCIEX	I
PE1B_RX_DN[7]	AJ42	PCIEX	I
PE1B_RX_DP[4]	AF42	PCIEX	I
PE1B_RX_DP[5]	AG43	PCIEX	I
PE1B_RX_DP[6]	AH42	PCIEX	I
PE1B_RX_DP[7]	AJ43	PCIEX	I
PE1B_TX_DN[4]	AY40	PCIEX	O
PE1B_TX_DN[5]	BA39	PCIEX	O
PE1B_TX_DN[6]	AY38	PCIEX	O
PE1B_TX_DN[7]	AW37	PCIEX	O
PE1B_TX_DP[4]	AW40	PCIEX	O
PE1B_TX_DP[5]	AY39	PCIEX	O
PE1B_TX_DP[6]	AW38	PCIEX	O
PE1B_TX_DP[7]	AV37	PCIEX	O
PE3A_RX_DN[0]	AH38	PCIEX	I
PE3A_RX_DN[1]	AJ39	PCIEX	I
PE3A_RX_DN[2]	AK38	PCIEX	I
PE3A_RX_DN[3]	AL39	PCIEX	I
PE3A_RX_DP[0]	AH39	PCIEX	I
PE3A_RX_DP[1]	AJ40	PCIEX	I
PE3A_RX_DP[2]	AK39	PCIEX	I
PE3A_RX_DP[3]	AL40	PCIEX	I
PE3A_TX_DN[0]	AU36	PCIEX	O
PE3A_TX_DN[1]	AT35	PCIEX	O
PE3A_TX_DN[2]	AU34	PCIEX	O
PE3A_TX_DN[3]	AT33	PCIEX	O
PE3A_TX_DP[0]	AT36	PCIEX	O
PE3A_TX_DP[1]	AR35	PCIEX	O



Table 4-1. Land Listing (Sheet 17 of 37)

Land Name	Land Number	Buffer Type	Direction
PE3A_TX_DP[2]	AT34	PCIEX	O
PE3A_TX_DP[3]	AR33	PCIEX	O
PE3B_RX_DN[4]	AM38	PCIEX	I
PE3B_RX_DN[5]	AN39	PCIEX	I
PE3B_RX_DN[6]	AP38	PCIEX	I
PE3B_RX_DN[7]	AR39	PCIEX	I
PE3B_RX_DP[4]	AM39	PCIEX	I
PE3B_RX_DP[5]	AN40	PCIEX	I
PE3B_RX_DP[6]	AP39	PCIEX	I
PE3B_RX_DP[7]	AR40	PCIEX	I
PE3B_TX_DN[4]	AU32	PCIEX	O
PE3B_TX_DN[5]	AV31	PCIEX	O
PE3B_TX_DN[6]	AU30	PCIEX	O
PE3B_TX_DN[7]	AV29	PCIEX	O
PE3B_TX_DP[4]	AT32	PCIEX	O
PE3B_TX_DP[5]	AU31	PCIEX	O
PE3B_TX_DP[6]	AT30	PCIEX	O
PE3B_TX_DP[7]	AU29	PCIEX	O
PE3C_RX_DN[10]	AM41	PCIEX	I
PE3C_RX_DN[11]	AN42	PCIEX	I
PE3C_RX_DN[8]	AK41	PCIEX	I
PE3C_RX_DN[9]	AL42	PCIEX	I
PE3C_RX_DP[10]	AM42	PCIEX	I
PE3C_RX_DP[11]	AN43	PCIEX	I
PE3C_RX_DP[8]	AK42	PCIEX	I
PE3C_RX_DP[9]	AL43	PCIEX	I
PE3C_TX_DN[10]	AY34	PCIEX	O
PE3C_TX_DN[11]	AW33	PCIEX	O
PE3C_TX_DN[8]	AY36	PCIEX	O
PE3C_TX_DN[9]	AW35	PCIEX	O
PE3C_TX_DP[10]	AW34	PCIEX	O
PE3C_TX_DP[11]	AV33	PCIEX	O
PE3C_TX_DP[8]	AW36	PCIEX	O
PE3C_TX_DP[9]	AV35	PCIEX	O
PE3D_RX_DN[12]	AP41	PCIEX	I
PE3D_RX_DN[13]	AR42	PCIEX	I
PE3D_RX_DN[14]	AT41	PCIEX	I

Table 4-1. Land Listing (Sheet 18 of 37)

Land Name	Land Number	Buffer Type	Direction
PE3D_RX_DN[15]	AU42	PCIEX	I
PE3D_RX_DP[12]	AP42	PCIEX	I
PE3D_RX_DP[13]	AR43	PCIEX	I
PE3D_RX_DP[14]	AT42	PCIEX	I
PE3D_RX_DP[15]	AU43	PCIEX	I
PE3D_TX_DN[12]	AY32	PCIEX	O
PE3D_TX_DN[13]	BA31	PCIEX	O
PE3D_TX_DN[14]	AY30	PCIEX	O
PE3D_TX_DN[15]	BA29	PCIEX	O
PE3D_TX_DP[12]	AW32	PCIEX	O
PE3D_TX_DP[13]	AY31	PCIEX	O
PE3D_TX_DP[14]	AW30	PCIEX	O
PE3D_TX_DP[15]	AY29	PCIEX	O
PECI	AN37	PCIEX	I/O
PM_FAST_WAKE_N	AW15	PCIEX	I/O
PMSYNC	AT3	CMOS	I
PRDY_N	AM7	CMOS	O
PREQ_N	AK7	CMOS	I/O
PROC_ID	BA15	NA	O
PROCHOT_N	AK9	ODCMOS	I/O
PWRGOOD	AT13	CMOS	I
PWR_DEBUG_N	AY15	CMOS	I
QPI1_CLKRX_DN	AN8	QPI	I
QPI1_CLKRX_DP	AP8	QPI	I
QPI1_CLKTX_DN	AY11	QPI	O
QPI1_CLKTX_DP	BA11	QPI	O
QPI1_DRX_DN[0]	AG5	QPI	I
QPI1_DRX_DN[1]	AG2	QPI	I
QPI1_DRX_DN[10]	AM1	QPI	I
QPI1_DRX_DN[11]	AM5	QPI	I
QPI1_DRX_DN[12]	AN2	QPI	I
QPI1_DRX_DN[13]	AN6	QPI	I
QPI1_DRX_DN[14]	AP1	QPI	I
QPI1_DRX_DN[15]	AP4	QPI	I
QPI1_DRX_DN[16]	AR2	QPI	I
QPI1_DRX_DN[17]	AR5	QPI	I
QPI1_DRX_DN[18]	AT1	QPI	I

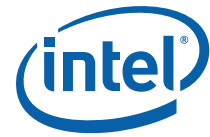


Table 4-1. Land Listing (Sheet 19 of 37)

Land Name	Land Number	Buffer Type	Direction
QPI1_DRX_DN[19]	AT4	QPI	I
QPI1_DRX_DN[2]	AH1	QPI	I
QPI1_DRX_DN[3]	AH5	QPI	I
QPI1_DRX_DN[4]	AJ2	QPI	I
QPI1_DRX_DN[5]	AJ6	QPI	I
QPI1_DRX_DN[6]	AK1	QPI	I
QPI1_DRX_DN[7]	AK5	QPI	I
QPI1_DRX_DN[8]	AL2	QPI	I
QPI1_DRX_DN[9]	AL6	QPI	I
QPI1_DRX_DP[0]	AG6	QPI	I
QPI1_DRX_DP[1]	AG3	QPI	I
QPI1_DRX_DP[10]	AM2	QPI	I
QPI1_DRX_DP[11]	AM4	QPI	I
QPI1_DRX_DP[12]	AN3	QPI	I
QPI1_DRX_DP[13]	AN5	QPI	I
QPI1_DRX_DP[14]	AP2	QPI	I
QPI1_DRX_DP[15]	AP5	QPI	I
QPI1_DRX_DP[16]	AR3	QPI	I
QPI1_DRX_DP[17]	AR6	QPI	I
QPI1_DRX_DP[18]	AT2	QPI	I
QPI1_DRX_DP[19]	AT5	QPI	I
QPI1_DRX_DP[2]	AH2	QPI	I
QPI1_DRX_DP[3]	AH4	QPI	I
QPI1_DRX_DP[4]	AJ3	QPI	I
QPI1_DRX_DP[5]	AJ5	QPI	I
QPI1_DRX_DP[6]	AK2	QPI	I
QPI1_DRX_DP[7]	AK4	QPI	I
QPI1_DRX_DP[8]	AL3	QPI	I
QPI1_DRX_DP[9]	AL5	QPI	I
QPI1_DTX_DN[0]	AV1	QPI	O
QPI1_DTX_DN[1]	AV4	QPI	O
QPI1_DTX_DN[10]	AW8	QPI	O
QPI1_DTX_DN[11]	AR10	QPI	O
QPI1_DTX_DN[12]	AY9	QPI	O
QPI1_DTX_DN[13]	AU11	QPI	O
QPI1_DTX_DN[14]	AV10	QPI	O
QPI1_DTX_DN[15]	AT12	QPI	O

Table 4-1. Land Listing (Sheet 20 of 37)

Land Name	Land Number	Buffer Type	Direction
QPI1_DTX_DN[16]	AU13	QPI	O
QPI1_DTX_DN[17]	AT14	QPI	O
QPI1_DTX_DN[18]	AY13	QPI	O
QPI1_DTX_DN[19]	AW14	QPI	O
QPI1_DTX_DN[2]	AW2	QPI	O
QPI1_DTX_DN[3]	AW5	QPI	O
QPI1_DTX_DN[4]	AY3	QPI	O
QPI1_DTX_DN[5]	AU7	QPI	O
QPI1_DTX_DN[6]	BA4	QPI	O
QPI1_DTX_DN[7]	AT8	QPI	O
QPI1_DTX_DN[8]	AY7	QPI	O
QPI1_DTX_DN[9]	AU9	QPI	O
QPI1_DTX_DP[0]	AV2	QPI	O
QPI1_DTX_DP[1]	AV5	QPI	O
QPI1_DTX_DP[10]	AY8	QPI	O
QPI1_DTX_DP[11]	AT10	QPI	O
QPI1_DTX_DP[12]	BA9	QPI	O
QPI1_DTX_DP[13]	AV11	QPI	O
QPI1_DTX_DP[14]	AW10	QPI	O
QPI1_DTX_DP[15]	AU12	QPI	O
QPI1_DTX_DP[16]	AV13	QPI	O
QPI1_DTX_DP[17]	AU14	QPI	O
QPI1_DTX_DP[18]	BA13	QPI	O
QPI1_DTX_DP[19]	AY14	QPI	O
QPI1_DTX_DP[2]	AW3	QPI	O
QPI1_DTX_DP[3]	AW6	QPI	O
QPI1_DTX_DP[4]	AY4	QPI	O
QPI1_DTX_DP[5]	AV7	QPI	O
QPI1_DTX_DP[6]	BA5	QPI	O
QPI1_DTX_DP[7]	AU8	QPI	O
QPI1_DTX_DP[8]	BA7	QPI	O
QPI1_DTX_DP[9]	AV9	QPI	O
RESET_N	AU2	CMOS	I
RSVD	A40		
RSVD	AD4		
RSVD	AE7		
RSVD	AF10		



Table 4-1. Land Listing (Sheet 21 of 37)

Land Name	Land Number	Buffer Type	Direction
RSVD	AF3		
RSVD	AF4		
RSVD	AF7		
RSVD	AG10		
RSVD	AG7		
RSVD	AG8		
RSVD	AG9		
RSVD	AH10		
RSVD	AH6		
RSVD	AH7		
RSVD	AH8		
RSVD	AH9		
RSVD	AJ11	RSVD	
RSVD	AJ8		
RSVD	AL14		
RSVD	AL15		
RSVD	AL9		
RSVD	AM15		
RSVD	AM28		
RSVD	AM37		
RSVD	AN15		
RSVD	AN28		
RSVD	AN32		
RSVD	AN33		
RSVD	AN34		
RSVD	AP15		
RSVD	AP28		
RSVD	AP31		
RSVD	AP32		
RSVD	AP33		
RSVD	AP35		
RSVD	AP7		
RSVD	AR28		
RSVD	AR31		
RSVD	AR7		
RSVD	AR9		
RSVD	AT15		

Table 4-1. Land Listing (Sheet 22 of 37)

Land Name	Land Number	Buffer Type	Direction
RSVD	AT28		
RSVD	AU15		
RSVD	AU28		
RSVD	AU3		
RSVD	AU4		
RSVD	AU6		
RSVD	AV28		
RSVD	AV42		
RSVD	AV43		
RSVD	AW13		
RSVD	AW42		
RSVD	AY28		
RSVD	AY41		
RSVD	AY6		
RSVD	B2		
RSVD	BA28		
RSVD	L40		
RSVD	M12		
RSVD	M14		
RSVD	M18		
RSVD	M20		
RSVD	M24		
RSVD	M26		
RSVD	M4		
RSVD	P34		
RSVD	R11		
RSVD	V34		
SAFE_MODE_BOOT	AU40	CMOS	I
SKTOCC_N	AR8	NA	O
SOCKET_ID[0]	AY12	CMOS	I
SVIDALERT_N	AK8	CMOS	I
SVIDCLK	AL8	ODCMOS	O
SVIDDATA	AJ10	ODCMOS	I/O
SYS_PWROK	AD38		
TCK	AM14	CMOS	I
TDI	AM12	CMOS	I
TDO	AM11	ODCMOS	O

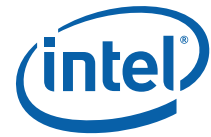


Table 4-1. Land Listing (Sheet 23 of 37)

Land Name	Land Number	Buffer Type	Direction
TEST[0]	F4		
TEST[1]	J4		
TEST[2]	AA34		
TEST[3]	G40		
TEST[4]	AP34		
THERMTRIP_N	AN9	ODCMOS	O
TMS	AL7	CMOS	I
TRST_N	AL12	CMOS	I
TXT_AGENT	C4	CMOS	I
TXT_PLTEN	AP36	CMOS	I
VCCD	D18	PWR	
VCCD	E16	PWR	
VCCD	E21	PWR	
VCCD	F12	PWR	
VCCD	F19	PWR	
VCCD	F24	PWR	
VCCD	F26	PWR	
VCCD	G22	PWR	
VCCD	H15	PWR	
VCCD	H20	PWR	
VCCD	J11	PWR	
VCCD	J13	PWR	
VCCD	K16	PWR	
VCCD	K18	PWR	
VCCD	K23	PWR	
VCCD	K27	PWR	
VCCIN	AA11	PWR	
VCCIN	AD11	PWR	
VCCIN	AE33	PWR	
VCCIN	AF9	PWR	
VCCIN	AG11	PWR	
VCCIN	AG33	PWR	
VCCIN	AJ33	PWR	
VCCIN	AK13	PWR	
VCCIN	AK17	PWR	
VCCIN	AK18	PWR	
VCCIN	AK19	PWR	

Table 4-1. Land Listing (Sheet 24 of 37)

Land Name	Land Number	Buffer Type	Direction
VCCIN	AK21	PWR	
VCCIN	AK22	PWR	
VCCIN	AK24	PWR	
VCCIN	AK25	PWR	
VCCIN	AK26	PWR	
VCCIN	AK27	PWR	
VCCIN	AK29	PWR	
VCCIN	AK30	PWR	
VCCIN	AK31	PWR	
VCCIN	AL17	PWR	
VCCIN	AL18	PWR	
VCCIN	AL19	PWR	
VCCIN	AL21	PWR	
VCCIN	AL22	PWR	
VCCIN	AL24	PWR	
VCCIN	AL25	PWR	
VCCIN	AL26	PWR	
VCCIN	AM17	PWR	
VCCIN	AM18	PWR	
VCCIN	AM19	PWR	
VCCIN	AM21	PWR	
VCCIN	AM22	PWR	
VCCIN	AM24	PWR	
VCCIN	AM25	PWR	
VCCIN	AM26	PWR	
VCCIN	AN17	PWR	
VCCIN	AN18	PWR	
VCCIN	AN19	PWR	
VCCIN	AN21	PWR	
VCCIN	AN22	PWR	
VCCIN	AN24	PWR	
VCCIN	AN25	PWR	
VCCIN	AN26	PWR	
VCCIN	AP17	PWR	
VCCIN	AP18	PWR	
VCCIN	AP19	PWR	
VCCIN	AP21	PWR	



Table 4-1. Land Listing (Sheet 25 of 37)

Land Name	Land Number	Buffer Type	Direction
VCCIN	AP22	PWR	
VCCIN	AP24	PWR	
VCCIN	AP25	PWR	
VCCIN	AP26	PWR	
VCCIN	AR17	PWR	
VCCIN	AR18	PWR	
VCCIN	AR19	PWR	
VCCIN	AR21	PWR	
VCCIN	AR22	PWR	
VCCIN	AR24	PWR	
VCCIN	AR25	PWR	
VCCIN	AR26	PWR	
VCCIN	AT17	PWR	
VCCIN	AT18	PWR	
VCCIN	AT19	PWR	
VCCIN	AT21	PWR	
VCCIN	AT22	PWR	
VCCIN	AT24	PWR	
VCCIN	AT25	PWR	
VCCIN	AT26	PWR	
VCCIN	AU17	PWR	
VCCIN	AU18	PWR	
VCCIN	AU19	PWR	
VCCIN	AU21	PWR	
VCCIN	AU22	PWR	
VCCIN	AU24	PWR	
VCCIN	AU25	PWR	
VCCIN	AU26	PWR	
VCCIN	AV17	PWR	
VCCIN	AV18	PWR	
VCCIN	AV19	PWR	
VCCIN	AV21	PWR	
VCCIN	AV22	PWR	
VCCIN	AV24	PWR	
VCCIN	AV25	PWR	
VCCIN	AV26	PWR	
VCCIN	AW17	PWR	

Table 4-1. Land Listing (Sheet 26 of 37)

Land Name	Land Number	Buffer Type	Direction
VCCIN	AW18	PWR	
VCCIN	AW19	PWR	
VCCIN	AW21	PWR	
VCCIN	AW22	PWR	
VCCIN	AW24	PWR	
VCCIN	AW25	PWR	
VCCIN	AW26	PWR	
VCCIN	AY17	PWR	
VCCIN	AY18	PWR	
VCCIN	AY19	PWR	
VCCIN	AY24	PWR	
VCCIN	AY25	PWR	
VCCIN	AY26	PWR	
VCCIN	BA17	PWR	
VCCIN	BA18	PWR	
VCCIN	BA19	PWR	
VCCIN	BA24	PWR	
VCCIN	BA25	PWR	
VCCIN	BA26	PWR	
VCCIN	T33	PWR	
VCCIN	U11	PWR	
VCCIN	W33	PWR	
VCCIN_SENSE	AB11	Analog	
VCCIO_IN	AK10	PWR	
VCCPECI	W11	PWR	
VSS	A4	GND	
VSS	A41	GND	
VSS	A5	GND	
VSS	AA10	GND	
VSS	AA33	GND	
VSS	AA37	GND	
VSS	AA4	GND	
VSS	AA40	GND	
VSS	AA7	GND	
VSS	AB10	GND	
VSS	AB33	GND	
VSS	AB36	GND	

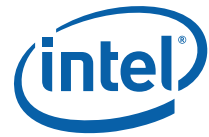


Table 4-1. Land Listing (Sheet 27 of 37)

Land Name	Land Number	Buffer Type	Direction
VSS	AB37	GND	
VSS	AB4	GND	
VSS	AB40	GND	
VSS	AB7	GND	
VSS	AC10	GND	
VSS	AC33	GND	
VSS	AC36	GND	
VSS	AC4	GND	
VSS	AC40	GND	
VSS	AC43	GND	
VSS	AC7	GND	
VSS	AD1	GND	
VSS	AD10	GND	
VSS	AD33	GND	
VSS	AD36	GND	
VSS	AD39	GND	
VSS	AD41	GND	
VSS	AD7	GND	
VSS	AE10	GND	
VSS	AE11	GND	
VSS	AE3	GND	
VSS	AE34	GND	
VSS	AE35	GND	
VSS	AE37	GND	
VSS	AE38	GND	
VSS	AE4	GND	
VSS	AE41	GND	
VSS	AE42	GND	
VSS	AF11	GND	
VSS	AF33	GND	
VSS	AF36	GND	
VSS	AF37	GND	
VSS	AF40	GND	
VSS	AF43	GND	
VSS	AF5	GND	
VSS	AF6	GND	
VSS	AF8	GND	

Table 4-1. Land Listing (Sheet 28 of 37)

Land Name	Land Number	Buffer Type	Direction
VSS	AG1	GND	
VSS	AG34	GND	
VSS	AG35	GND	
VSS	AG38	GND	
VSS	AG4	GND	
VSS	AG41	GND	
VSS	AH11	GND	
VSS	AH33	GND	
VSS	AH36	GND	
VSS	AH37	GND	
VSS	AH40	GND	
VSS	AH43	GND	
VSS	AJ1	GND	
VSS	AJ35	GND	
VSS	AJ38	GND	
VSS	AJ4	GND	
VSS	AJ41	GND	
VSS	AJ7	GND	
VSS	AJ9	GND	
VSS	AK12	GND	
VSS	AK14	GND	
VSS	AK16	GND	
VSS	AK20	GND	
VSS	AK23	GND	
VSS	AK28	GND	
VSS	AK3	GND	
VSS	AK32	GND	
VSS	AK33	GND	
VSS	AK37	GND	
VSS	AK40	GND	
VSS	AK43	GND	
VSS	AK6	GND	
VSS	AL1	GND	
VSS	AL13	GND	
VSS	AL16	GND	
VSS	AL20	GND	
VSS	AL23	GND	





Table 4-1. Land Listing (Sheet 29 of 37)

Land Name	Land Number	Buffer Type	Direction
VSS	AL27	GND	
VSS	AL28	GND	
VSS	AL29	GND	
VSS	AL30	GND	
VSS	AL31	GND	
VSS	AL32	GND	
VSS	AL35	GND	
VSS	AL38	GND	
VSS	AL4	GND	
VSS	AL41	GND	
VSS	AM10	GND	
VSS	AM13	GND	
VSS	AM16	GND	
VSS	AM20	GND	
VSS	AM23	GND	
VSS	AM27	GND	
VSS	AM29	GND	
VSS	AM31	GND	
VSS	AM34	GND	
VSS	AM40	GND	
VSS	AM43	GND	
VSS	AM8	GND	
VSS	AM9	GND	
VSS	AN1	GND	
VSS	AN12	GND	
VSS	AN14	GND	
VSS	AN16	GND	
VSS	AN20	GND	
VSS	AN23	GND	
VSS	AN27	GND	
VSS	AN29	GND	
VSS	AN31	GND	
VSS	AN35	GND	
VSS	AN36	GND	
VSS	AN38	GND	
VSS	AN4	GND	
VSS	AN41	GND	

Table 4-1. Land Listing (Sheet 30 of 37)

Land Name	Land Number	Buffer Type	Direction
VSS	AN7	GND	
VSS	AP14	GND	
VSS	AP16	GND	
VSS	AP20	GND	
VSS	AP23	GND	
VSS	AP27	GND	
VSS	AP29	GND	
VSS	AP3	GND	
VSS	AP30	GND	
VSS	AP37	GND	
VSS	AP40	GND	
VSS	AP43	GND	
VSS	AP6	GND	
VSS	AP9	GND	
VSS	AR1	GND	
VSS	AR12	GND	
VSS	AR13	GND	
VSS	AR14	GND	
VSS	AR15	GND	
VSS	AR16	GND	
VSS	AR20	GND	
VSS	AR23	GND	
VSS	AR27	GND	
VSS	AR32	GND	
VSS	AR34	GND	
VSS	AR36	GND	
VSS	AR38	GND	
VSS	AR4	GND	
VSS	AR41	GND	
VSS	AT11	GND	
VSS	AT16	GND	
VSS	AT20	GND	
VSS	AT23	GND	
VSS	AT27	GND	
VSS	AT29	GND	
VSS	AT31	GND	
VSS	AT39	GND	



Table 4-1. Land Listing (Sheet 31 of 37)

Land Name	Land Number	Buffer Type	Direction
VSS	AT40	GND	
VSS	AT43	GND	
VSS	AT7	GND	
VSS	AT9	GND	
VSS	AU1	GND	
VSS	AU10	GND	
VSS	AU16	GND	
VSS	AU20	GND	
VSS	AU23	GND	
VSS	AU27	GND	
VSS	AU33	GND	
VSS	AU35	GND	
VSS	AU37	GND	
VSS	AU41	GND	
VSS	AU5	GND	
VSS	AV12	GND	
VSS	AV14	GND	
VSS	AV16	GND	
VSS	AV20	GND	
VSS	AV23	GND	
VSS	AV27	GND	
VSS	AV3	GND	
VSS	AV30	GND	
VSS	AV32	GND	
VSS	AV34	GND	
VSS	AV36	GND	
VSS	AV38	GND	
VSS	AV40	GND	
VSS	AV6	GND	
VSS	AV8	GND	
VSS	AW1	GND	
VSS	AW11	GND	
VSS	AW12	GND	
VSS	AW16	GND	
VSS	AW20	GND	
VSS	AW23	GND	
VSS	AW27	GND	

Table 4-1. Land Listing (Sheet 32 of 37)

Land Name	Land Number	Buffer Type	Direction
VSS	AW28	GND	
VSS	AW29	GND	
VSS	AW31	GND	
VSS	AW39	GND	
VSS	AW4	GND	
VSS	AW7	GND	
VSS	AW9	GND	
VSS	AY10	GND	
VSS	AY16	GND	
VSS	AY2	GND	
VSS	AY20	GND	
VSS	AY27	GND	
VSS	AY33	GND	
VSS	AY35	GND	
VSS	AY37	GND	
VSS	AY42	GND	
VSS	AY5	GND	
VSS	B12	GND	
VSS	B17	GND	
VSS	B3	GND	
VSS	B33	GND	
VSS	B38	GND	
VSS	B40	GND	
VSS	B42	GND	
VSS	BA10	GND	
VSS	BA12	GND	
VSS	BA14	GND	
VSS	BA16	GND	
VSS	BA20	GND	
VSS	BA27	GND	
VSS	BA3	GND	
VSS	BA30	GND	
VSS	BA32	GND	
VSS	BA40	GND	
VSS	BA6	GND	
VSS	BA8	GND	
VSS	C10	GND	



Table 4-1. Land Listing (Sheet 33 of 37)

Land Name	Land Number	Buffer Type	Direction
VSS	C15	GND	
VSS	C2	GND	
VSS	C20	GND	
VSS	C25	GND	
VSS	C27	GND	
VSS	C28	GND	
VSS	C29	GND	
VSS	C30	GND	
VSS	C31	GND	
VSS	C32	GND	
VSS	C33	GND	
VSS	C40	GND	
VSS	C43	GND	
VSS	C5	GND	
VSS	C6	GND	
VSS	C7	GND	
VSS	C8	GND	
VSS	C9	GND	
VSS	D1	GND	
VSS	D13	GND	
VSS	D35	GND	
VSS	D36	GND	
VSS	D38	GND	
VSS	D39	GND	
VSS	D4	GND	
VSS	E11	GND	
VSS	E23	GND	
VSS	E34	GND	
VSS	E37	GND	
VSS	E4	GND	
VSS	E40	GND	
VSS	F10	GND	
VSS	F14	GND	
VSS	F27	GND	
VSS	F28	GND	
VSS	F29	GND	
VSS	F30	GND	

Table 4-1. Land Listing (Sheet 34 of 37)

Land Name	Land Number	Buffer Type	Direction
VSS	F31	GND	
VSS	F32	GND	
VSS	F33	GND	
VSS	F34	GND	
VSS	F37	GND	
VSS	F40	GND	
VSS	F5	GND	
VSS	F6	GND	
VSS	F7	GND	
VSS	F8	GND	
VSS	F9	GND	
VSS	G17	GND	
VSS	G34	GND	
VSS	G37	GND	
VSS	G4	GND	
VSS	G41	GND	
VSS	G42	GND	
VSS	G43	GND	
VSS	H1	GND	
VSS	H2	GND	
VSS	H3	GND	
VSS	H34	GND	
VSS	H37	GND	
VSS	H4	GND	
VSS	H40	GND	
VSS	J10	GND	
VSS	J28	GND	
VSS	J29	GND	
VSS	J30	GND	
VSS	J31	GND	
VSS	J32	GND	
VSS	J33	GND	
VSS	J34	GND	
VSS	J37	GND	
VSS	J40	GND	
VSS	J42	GND	
VSS	J5	GND	



Table 4-1. Land Listing (Sheet 35 of 37)

Land Name	Land Number	Buffer Type	Direction
VSS	J6	GND	
VSS	J7	GND	
VSS	J8	GND	
VSS	J9	GND	
VSS	K2	GND	
VSS	K21	GND	
VSS	K25	GND	
VSS	K34	GND	
VSS	K37	GND	
VSS	K4	GND	
VSS	K40	GND	
VSS	L35	GND	
VSS	L36	GND	
VSS	L38	GND	
VSS	L39	GND	
VSS	L4	GND	
VSS	M10	GND	
VSS	M11	GND	
VSS	M13	GND	
VSS	M15	GND	
VSS	M16	GND	
VSS	M17	GND	
VSS	M19	GND	
VSS	M21	GND	
VSS	M22	GND	
VSS	M23	GND	
VSS	M25	GND	
VSS	M27	GND	
VSS	M28	GND	
VSS	M29	GND	
VSS	M30	GND	
VSS	M31	GND	
VSS	M32	GND	
VSS	M33	GND	
VSS	M34	GND	
VSS	M37	GND	
VSS	M40	GND	

Table 4-1. Land Listing (Sheet 36 of 37)

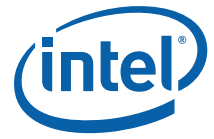
Land Name	Land Number	Buffer Type	Direction
VSS	M43	GND	
VSS	M5	GND	
VSS	M6	GND	
VSS	M8	GND	
VSS	M9	GND	
VSS	N1	GND	
VSS	N11	GND	
VSS	N2	GND	
VSS	N33	GND	
VSS	N37	GND	
VSS	N4	GND	
VSS	N40	GND	
VSS	N41	GND	
VSS	N42	GND	
VSS	N7	GND	
VSS	P11	GND	
VSS	P2	GND	
VSS	P3	GND	
VSS	P33	GND	
VSS	P37	GND	
VSS	P40	GND	
VSS	P7	GND	
VSS	R10	GND	
VSS	R33	GND	
VSS	R34	GND	
VSS	R37	GND	
VSS	R4	GND	
VSS	R40	GND	
VSS	R7	GND	
VSS	T10	GND	
VSS	T11	GND	
VSS	T34	GND	
VSS	T37	GND	
VSS	T4	GND	
VSS	T40	GND	
VSS	T42	GND	
VSS	T7	GND	



Table 4-1. Land Listing (Sheet 37 of 37)

§

Land Name	Land Number	Buffer Type	Direction
VSS	U10	GND	
VSS	U2	GND	
VSS	U33	GND	
VSS	U34	GND	
VSS	U37	GND	
VSS	U4	GND	
VSS	U40	GND	
VSS	U7	GND	
VSS	V11	GND	
VSS	V33	GND	
VSS	V35	GND	
VSS	V36	GND	
VSS	V38	GND	
VSS	V39	GND	
VSS	V4	GND	
VSS	V41	GND	
VSS	V42	GND	
VSS	V43	GND	
VSS	V7	GND	
VSS	W1	GND	
VSS	W2	GND	
VSS	W3	GND	
VSS	W34	GND	
VSS	W37	GND	
VSS	W40	GND	
VSS	W5	GND	
VSS	W8	GND	
VSS	W9	GND	
VSS	Y11	GND	
VSS	Y33	GND	
VSS	Y34	GND	
VSS	Y37	GND	
VSS	Y4	GND	
VSS	Y40	GND	
VSS	Y7	GND	
VSS_VCCIN_SENSE	AC11	Analog	



## X-ON Electronics

Largest Supplier of Electrical and Electronic Components

*Click to view similar products for CPU - Central Processing Units category:*

*Click to view products by Intel manufacturer:*

Other Similar products are found below :

[D8751H](#) [AT80612003090AAS LBWJ](#) [N87C51](#) [IVPX7225-RTM-1](#) [CM8063401286600S R1AK](#) [CM8063501374802S R1A5](#)  
[CM8063501375101S R1A8](#) [MATXM-CORE-411-HTSNK](#) [BGSF 1717MN26 E6327](#) [BX80621E52620 S R0KW](#) [IVPX7225-02250813L](#)  
[D8086-2](#) [CM8063401293902S R1A4](#) [CM8063501374901S R1A6](#) [CM8066201928505 SR2HT](#) [CM8063501293200S R1A0](#)  
[CM8062301046008S R060](#) [ATLASEDGE.1](#) [AV8063801129600S R10F](#) [R0K5ML001SS00BR](#) [CM8066201921712S R2LF](#)  
[CM8064601467102S R152](#) [CM8063701094000S R0TA](#) [CM8063501375800S R1AX](#) [CM8063401376400S R1A9](#) [CM8063401293802S R1A3](#)  
[CM8063401286102S R19S](#) [CM8062107185405S R0KM](#) [CM8066002032201S R2R6](#) [CM8063501288301S R1AN](#) [COMX-300-HSP](#) [RTM-](#)  
[ATCA-7360](#) [96MPI7-3.4-8M11T](#) [96MPP-2.3-3M10T](#) [96MPI7-3.4-8M11T1](#) [96MPXE-2.0-15M20T](#) [96MPI5-3.0-6M10T](#) [96MPI5S-2.3-](#)  
[6M11T1](#) [FJ8066401715827S R2KG](#) [AFPC205 S R1Z1](#) [DNCE2510 S LHCM](#) [FJ8066401715843S R2KH](#) [DNCE2530G S LHCY](#)  
[DNCE2510GU S LHCW](#) [CM8066201935807S R2LM](#) [FH8065503554000S R3H4](#) [FH8065301615104S R1UU](#) [CM8066201934909S R2LK](#)  
[FJ8067702739633S R340](#) [CM8068403360212 SR3XB](#)