



# **Cyclone III 3C120 Development Board Reference Manual**

---



101 Innovation Drive  
San Jose, CA 95134  
[www.altera.com](http://www.altera.com)

Document Version: 1.4  
Document Date: March 2009

Copyright © 2009 Altera Corporation. All rights reserved. Altera, The Programmable Solutions Company, the stylized Altera logo, specific device designations, and all other words and logos that are identified as trademarks and/or service marks are, unless noted otherwise, the trademarks and service marks of Altera Corporation in the U.S. and other countries. All other product or service names are the property of their respective holders. Altera products are protected under numerous U.S. and foreign patents and pending applications, maskwork rights, and copyrights. Altera warrants performance of its semiconductor products to current specifications in accordance with Altera's standard warranty, but reserves the right to make changes to any products and services at any time without notice. Altera assumes no responsibility or liability arising out of the application or use of any information, product, or service described herein except as expressly agreed to in writing by Altera Corporation. Altera customers are advised to obtain the latest version of device specifications before relying on any published information and before placing orders for products or services.

## Chapter 1. Overview

Introduction .....	1-1
General Description .....	1-1
Board Component Blocks .....	1-2
Block Diagram .....	1-4
Handling the Board .....	1-5

## Chapter 2. Board Components

Introduction .....	2-1
Board Overview .....	2-1
Featured FPGA (U20) .....	2-4
I/O and Clocking Resources .....	2-5
MAX II CPLD .....	2-6
Configuration, Status, and Setup Elements .....	2-14
Configuration .....	2-15
FPGA Programming Over USB .....	2-15
FPGA Programming from Flash Memory .....	2-16
Flash Programming over USB Interface .....	2-17
Status Elements .....	2-17
Board Specific LEDs .....	2-17
Power Display (U28) .....	2-18
Setup Elements .....	2-18
JTAG Control DIP Switch .....	2-19
MAX II Device Control DIP Switch .....	2-20
System Reset and Configuration Switches .....	2-20
POWER SELECT Rotary Switch .....	2-21
PGM CONFIG SELECT Rotary Switch .....	2-22
Speaker Header (J5) .....	2-22
Clocking Circuitry .....	2-23
Cyclone III FPGA Clock Inputs .....	2-23
Cyclone III FPGA Clock Outputs .....	2-24
Oscillators .....	2-25
General User Interfaces .....	2-26
User-Defined Push Button Switches .....	2-26
User-Defined DIP Switches .....	2-27
User-Defined LEDs .....	2-27
General User-Defined LEDs .....	2-27
HSMC User-Defined LEDs .....	2-28
DDR2 User-Defined LEDs .....	2-29
7-Segment Displays .....	2-30
User 7-Segment Display .....	2-30
Power 7-Segment Display .....	2-31
LCD Information .....	2-31
Character LCD (J4) .....	2-32
Graphics LCD (J13) .....	2-33

---

Communication Ports and Interfaces .....	2-37
USB 2.0 MAC/PHY .....	2-38
10/100/1000 Ethernet .....	2-40
High-Speed Mezzanine Connector .....	2-42
On-Board Memory .....	2-48
DDR2 SDRAM .....	2-48
SRAM .....	2-54
Flash Memory .....	2-58
Power Supply .....	2-62
Power Measurement .....	2-64
Statement of China-RoHS Compliance .....	2-64

**Additional Information**

Revision History .....	About-1
How to Contact Altera .....	About-2
Typographic Conventions .....	About-2

## Introduction

This document describes the hardware features of the Cyclone® III development board, including detailed pin-out information to enable you to create custom FPGA designs that interface with all components of the board.

- For information about setting up and powering up the Cyclone III development board and using the kit's demo software, refer to the *Cyclone III Development Kit User Guide*.

## General Description

The Cyclone® III development board provides a hardware platform for developing and prototyping low-power, high-volume, and feature-rich designs as well as to demonstrate the Cyclone III device's on-chip memory, embedded multipliers, and the Nios® II embedded processor.

With up to 4 Mbits of embedded memory and 288 embedded 18-bit × 18-bit multipliers, the Cyclone III device supplies internal memory while also providing external support for high-speed, low-latency memory access via dual-channel DDR SDRAM and low-power SRAM.

Built on TSMC's 65-nm low-power process technology, Cyclone III devices are designed to provide low static and dynamic power consumption. Additionally, with the support of the Quartus® II software's PowerPlay technology, designs are automatically optimized for power consumption. Therefore, the Cyclone III development board provides a power-optimized, integrated solution for memory-intensive, high-volume applications.

Accordingly, the Cyclone III development board is especially suitable for wireless, video and image processing, and other high-bandwidth, parallel processing applications. Through the use of Altera®-provided video and image intellectual property (or other MegaCore® functions) and board expansion connectors, you can enable the inter-operability of the Cyclone III device, allowing application-specific customization of the development board.

- For more information about the Altera Video and Image Processing Suite MegaCore functions, refer to the *Video and Image Processing Suite User Guide*.

To get you started, Altera provides application-specific design examples. The pre-built and tested design examples allow you to:

- Create a Cyclone III FPGA design in an hour
- View Cyclone III FPGA power measurement examples
- Design a 32-bit soft processor system inside the Cyclone III FPGA in an hour

The Cyclone III development board has the following main features:

- High logic density to implement more functions and features
- Embedded memory for high-bandwidth applications
- Expandable through two Altera High-Speed Mezzanine Connectors (HSMCs)
- 256-MB of dual channel DDR2 SDRAM with a 72-bit data width
- Supports high-speed external memory interfaces including dual-channel DDR SDRAM and low-power SRAM
- Four user push-button switches
- Eight user LEDs
- Power consumption display

The Cyclone III development board provides the following advantages:

- Unique combination of low-cost, low-power Cyclone III FPGA that supports high-volume, memory-intensive designs
- Highest multiplier-to-logic ratio FPGA in the industry
- Lowest cost, density- and power-optimized FPGA
- Quartus II development software's power optimization tools

## Board Component Blocks

The board features the following major component blocks:

- 780-pin Altera Cyclone III EP3C120 FPGA in a BGA package
  - 119K logic elements (LEs)
  - 3,888 Kbits of memory
  - 288 18 × 18 multiplier blocks
  - Four phase locked loops (PLLs)
  - 20 global clock networks
  - 531 user I/Os
  - 1.2-V core power
- 256-pin Altera MAX<sup>®</sup> II EPM2210G CPLD in a FineLine Ball Grid Array (FBGA) package
  - 1.8-V core power
- On-board memory
  - 256-MB dual-channel DDR2 SDRAM
  - 8-MB SRAM
  - 64-MB flash memory

- FPGA configuration circuitry
  - MAX II CPLD and flash passive serial configuration
  - On-board USB-Blaster™ circuitry using the Quartus II Programmer
- On-board clocking circuitry
  - Two clock oscillators to support Cyclone III device user logic
    - 50 MHz
    - 125 MHz
  - 80 I/O, 6 clocks, SMBus, and JTAG
  - SMA connector for external clock input and output
- General user and configuration interfaces
  - LEDs/displays:
    - Eight user LEDs
    - One transmit/receive LED (TX/RX) per HSMC interface
    - One configuration done LED
    - Ethernet LEDs
    - User 7-segment display
    - Power consumption display
  - Memory activity LEDs:
    - SRAM
    - FLASH
    - DDR2 Top
    - DDR2 Bottom
  - Push-buttons:
    - One user reset push-button (CPU reset)
    - Four general user push-buttons
    - One system reset push-button (user configuration)
    - One factory push-button switch (factory configuration)
  - DIP switches:
    - One MAX control DIP switch
    - One JTAG control switch
    - Eight user DIP switches
    - Speaker header
- Displays
  - 128 × 64 graphics LCD
  - 16 × 2 line character LCD

- Power supply
  - 14 V – 20 V DC input
  - On-board power measurement circuitry
  - Up to 19.8 W per HSMC interface
- Mechanical
  - 6" × 8" board
  - Bench-top design

 The Cyclone III FPGA Development Kit ships with additional HSMC daughter card loopback and break-out headers for convenient testing of some of the HSMC signals. For more details regarding these test daughter cards, refer to their respective schematics at these locations in the installed kit directory:

- `<path>\board_design_files\schematic\breakout_hsmc_debug_header_breakout.pdf`
- `<path>\board_design_files\schematic\loopback_hsmc_loopback_test_lowcost.pdf`

## Block Diagram

Figure 1-1 shows the functional block diagram of the Cyclone III development board.

**Figure 1-1.** Cyclone III Development Board Block Diagram

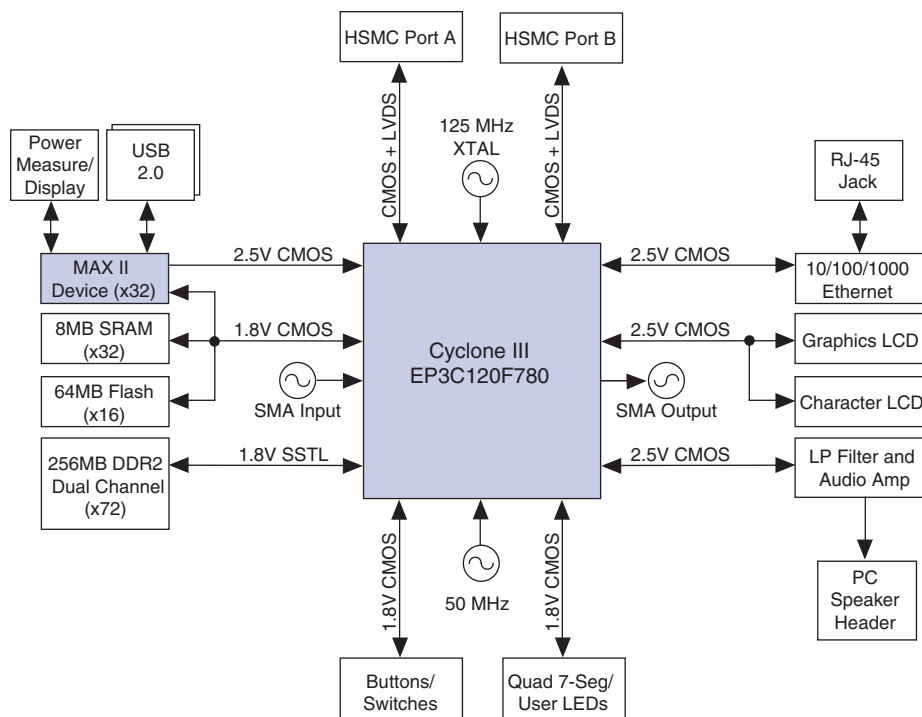



## Handling the Board

When handling the board, it is important to observe the following precaution:



Static Discharge Precaution: Without proper anti-static handling, the board can be damaged. Therefore, use anti-static handling precautions when touching the board.



### Introduction

This chapter introduces all the important components on the Cyclone III development board. [Figure 2-1](#) illustrates all component locations and [Table 2-1](#) describes component features.

The chapter is divided into the following sections:

- “Featured FPGA (U20)” on page 2-4
- “MAX II CPLD” on page 2-6
- “Configuration, Status, and Setup Elements” on page 2-14
- “Clocking Circuitry” on page 2-23
- “General User Interfaces” on page 2-26
- “Communication Ports and Interfaces” on page 2-37
- “On-Board Memory” on page 2-48
- “Power Supply” on page 2-62
- “Statement of China-RoHS Compliance” on page 2-64



A complete set of board schematics, a physical layout database, and GERBER files for the Cyclone III development board are installed in the Cyclone III Development Kit documents directory.



For information about powering up the development board and installing the demo software, refer to the [Cyclone III Development Kit User Guide](#).

### Board Overview

This section provides an overview of the Cyclone III development board, including an annotated board image and component descriptions.

[Figure 2-1](#) shows the top view of the Cyclone III development board.

**Figure 2-1.** Top View of the Cyclone III Development Board

Table 2-1 describes the components and lists their corresponding board references.

**Table 2-1.** Cyclone III Development Board (Part 1 of 3)

Board Reference	Type	Description
<b>Featured Devices</b>		
U20	FPGA	EP3C120, 780-pin FineLine BGA package.
U7	CPLD	EPM2210G, 256-pin device in a FineLine BGA package.
<b>Configuration Status and Setup Elements</b>		
J6	Device select (DEV_SEL) jumper	Sets target device for JTAG signals when using an external USB-Blaster or equivalent.
J3	Input	Type B USB connector that allows for connecting a Type A-B USB cable between a PC and the board.
D20 through D24	User LEDs	Board-specific configuration green LEDs.
D25	Configuration done LED	Green LED that illuminates when the FPGA is successfully configured.
D12 through D15	Channel activity LEDs	Green LEDs that indicate the RX and TX activity on the HSMC Ports A or B.

**Table 2–1.** Cyclone III Development Board (Part 2 of 3)

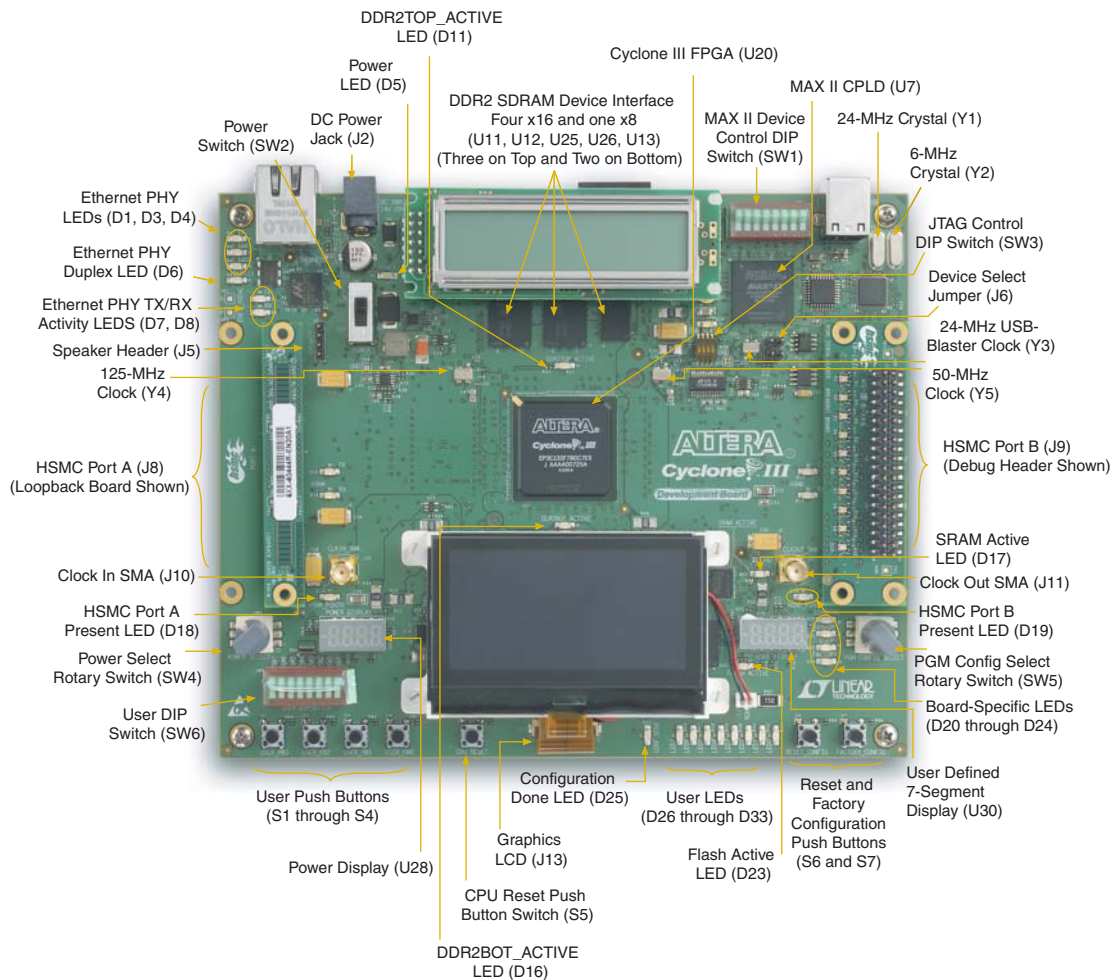
<b>Board Reference</b>	<b>Type</b>	<b>Description</b>
J5	Header	Speaker header.
D1, D3, D4	Ethernet PHY LEDs	Green Ethernet PHY LEDs. Illuminate when Ethernet PHY is using the 10/100/1000 Mbps (D1, D3, D4) connection speeds.
D6	Duplex Ethernet PHY LED	Green Ethernet PHY LED. Illuminates when Ethernet PHY is both sending and receiving data.
D5	Power LED	Blue LED indicates when power is applied to the board.
D7, D8	Ethernet PHY transmit/receive activity LEDs	Green LED. Illuminates when transmit/receive data is active from the Ethernet PHY.
SW1	MAX II device control DIP switch	Controls various features specific to the Cyclone III development board.
SW3	JTAG control switch	JTAG control DIP switch used to remove or include devices in the active JTAG chain.
D17	SRAM active	SRAM active LED. Illuminates when the SRAM device is accessed.
D23	Flash active	Flash active LED. Illuminates when the flash device is accessed.
U28	Power display	Displays power measured by the MAX II CPLD.
D16	DDR2 LED	Indicates that the DDR2 top devices are active.
D11	DDR2 LED	Indicates that the DDR2 bottom devices are active.
<b>Clock Circuitry</b>		
Y4	125 MHz	125-MHz clock oscillator used for the system clock.
Y5	50 MHz	50-MHz clock oscillator used for data processing.
Y1	24-MHz crystal	Cypress USB PHY.
Y2	6-MHz crystal	USB PHY FTDI reference clock.
Y3	24 MHz	MAX II device clock.
J10	SMA clock input	SMA connector that allows the provision of an external clock input.
J11	SMA clock output	SMA connector that allows the provision of an external clock output.
<b>General User Input and Output</b>		
S1 through S4	User push buttons	Four 1.8-V push-button switches for user-defined, logic inputs.
S5	CPU reset push button	One 1.8-V push-button switch for FPGA logic and CPU reset.
S6 and S7	Reset and factory configuration push buttons	Two 1.8-V push-button switches that control FPGA configuration from flash memory.
D26 through D33	User LEDs	Eight user-defined LEDs.
SW5	PGM CONFIG SELECT	Rotary switch to select which FPGA configuration file to use in flash memory.
SW4	Power select rotary switch	Power rail select for on-board power monitor.
U30	User display	User-defined, green 7-segment display.
J4	Character LCD	14-pin LCD display.
J13	Graphics LCD	30-position dot matrix graphics LCD display.
<b>Memory</b>		
U31	Flash	64 MB of flash memory with a 16-bit data bus.

**Table 2-1.** Cyclone III Development Board (Part 3 of 3)

Board Reference	Type	Description
U23 and U24	SRAM	The SRAM devices connect to the MAX II device as well as the flash memory device.
U11, U12, U13, U25, U26	DDR2 SDRAM	Four ×16 devices and a single ×8 device.
<b>Components and Interfaces</b>		
U6	USB device	USB device that provides JTAG programming of on-board devices, including the Cyclone III device and flash memory device.
U3	Ethernet cable jack	The RF-45 jack is for Ethernet cable connection. The connector is fed by a 10/100/1000 base T PHY device with an RGMII interface to the Cyclone III device.
J8, J9	HSMC Port A and Port B	High-speed mezzanine header allows for the connection of HSMC daughter cards.
<b>Power Supply</b>		
J2	DC power jack	14–20 V DC power source.
SW2	Input	Switches the board's power on and off.

## Featured FPGA (U20)

The Cyclone III Development Kit features the EP3C120F780 device (U20) in a 780-pin BGA package.

 For more information about Cyclone III devices, refer to the [Cyclone III Device Handbook](#).

[Table 2-2](#) lists the main Cyclone III device features.

**Table 2-2.** Cyclone III Device Features

Feature	Quantity
Logic elements	119,088
Memory (Kbits)	3,888
Multipliers	288
PLLs	4
Global clock networks	20

[Table 2-3](#) lists the Cyclone III component reference and manufacturing information.

**Table 2-3.** Cyclone III Component Reference and Manufacturing Information

Board Reference	Description	Manufacturer	Manufacturing Part Number	Manufacturer Website
U20	Memory rich FPGA device	Altera Corporation	EP3C120F780	<a href="http://www.altera.com">www.altera.com</a>

Table 2-4 lists the Cyclone III EP3C120F780C7 device pin count.

**Table 2-4.** Cyclone III Device Pin Count

Function	I/O Type	I/O Count	Special Pins
Oscillators and SMAs	1.8-V CMOS	4	Three clock inputs, one output
DDR2	1.8-V SSTL	148	Nine data strobe signal (DQS), 10 V <sub>REF</sub>
Flash/SRAM/MAX	1.8-V CMOS	78	—
Horizontal bank OCT calibration	1.8-V CMOS	4	2 Rup, 2 Rdn
Vertical bank OCT calibration	2.5-V CMOS	4	2 Rup, 2 Rdn
Passive serial configuration	2.5-V CMOS	2	DATA0, DCLK
Ethernet	2.5-V CMOS	16	1 clock input
Buttons, Switches, LEDs	1.8-V CMOS	34	DEV_CLR
Character LCD, Graphics LCD	2.5-V CMOS	14	—
Speaker header	2.5-V CMOS	1	—
USB	2.5-V CMOS	14	1 clock input
HSMC Port A	2.5-V CMOS 2.5-V LVDS	86	5 clock inputs (1 single-ended, 2 differential)
HSMC Port B	2.5-V CMOS 2.5-V LVDS	86	5 clock inputs (1 single-ended, 2 differential)
Device I/O total: 491			



For additional information about Altera devices, go to [www.altera.com/products/devices](http://www.altera.com/products/devices).

## I/O and Clocking Resources

This section lists specific I/O and clocking resources available with the EP3C120F780C7 device, which is the largest of the Cyclone III devices.

Figure 2-2 illustrates the available I/O bank resources on the EP3C120F780C7 device.

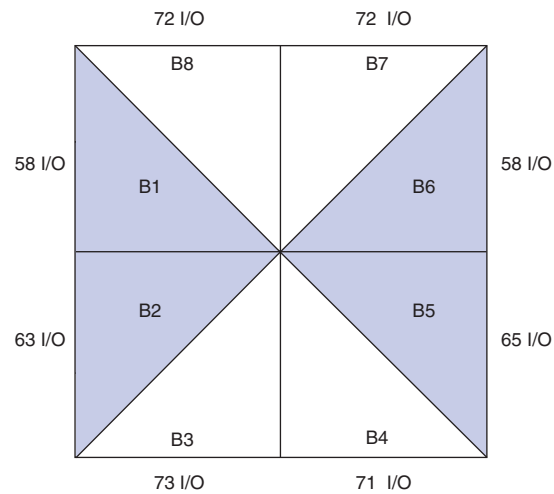
**Figure 2-2.** Cyclone III Device I/O Bank Resources

## MAX II CPLD

The board utilizes an Altera MAX II CPLD for the following purposes:

- Power-up configuration of the FPGA from flash memory
- Embedded USB-Blaster core for USB-based configuration of the FPGA
- Power consumption monitoring and display

There are two USB MAC/PHY devices—FTDI and Cypress USB PHY devices—on the board. They are muxed through the MAX II CPLD. Only one can operate at any time. The FTDI device is the default device and it supports the embedded blaster functionality. The Cypress USB PHY is held in reset and is reserved for future use. Each device has a shared path between the USB device and the MAX II CPLD. The individual paths then drive to the FPGA separately. [Figure 2-3](#) illustrates the MAX II device's block diagram.



Figure 2-3. MAX II Device's Block Diagram

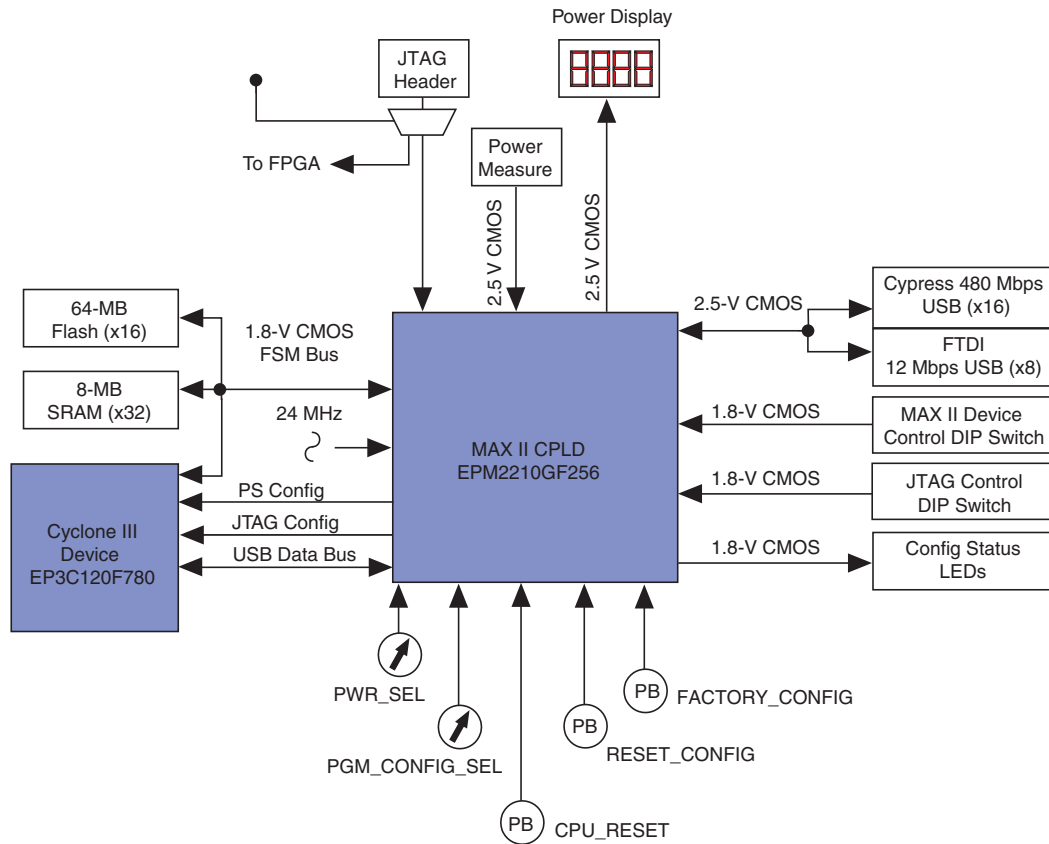

Table 2-5 lists the I/O signals present on the MAX II CPLD. The signal name and function are relative to the MAX II device.

Table 2-5. MAX II Device Pin-Out (Note 1) (Part 1 of 8)

MAX II Pin Number	I/O Standard	Signal Direction	Schematic Signal Name
P3	—	Input	TCK
L6	—	Input	TDI
M5	—	Output	TDO
N4	—	Input	TMS
C14	1.8 V	Output	CLKIN_125_EN
J12	1.8 V	Input	CLKIN_24
E13	1.8 V	Output	CLKIN_50_EN
M9	1.8 V	Input	CPU_RESETh
F11	1.8 V	Input	DEV_SEL
A10	2.5 V	Input	FACTORY_CONFIGn
G13	1.8 V	Output	FLASH_ACTIVE
L15	1.8 V	Output	FLASH_BYTEh
K14	1.8 V	Output	FLASH_CEn

Table 2-5. MAX II Device Pin-Out (Note 1) (Part 2 of 8)

MAX II Pin Number	I/O Standard	Signal Direction	Schematic Signal Name
M16	1.8 V	Output	FLASH_OEn
L11	1.8 V	Input	FLASH_RDYBSYn
M15	1.8 V	Output	FLASH_RESEn
L12	1.8 V	Output	FLASH_WEn
J16	1.8 V	Input	FPGA_BYPASS
E3	2.5 V	Input	FPGA_CONF_DONE
D3	2.5 V	Output	FPGA_DATA
C2	2.5 V	Output	FPGA_DCLK
N3	2.5 V	Input	FPGA_JTAG_TCK
N1	2.5 V	Output	FPGA_JTAG_TDI
N2	2.5 V	Input	FPGA_JTAG_TDO
P2	2.5 V	Input	FPGA_JTAG_TMS
E4	2.5 V	Output	FPGA_nCONFIG
C3	2.5 V	Input	FPGA_nSTATUS
N9	1.8 V	Output	FSA [0]
T8	1.8 V	Output	FSA [1]
N10	1.8 V	Output	FSA [10]
R11	1.8 V	Output	FSA [11]
P10	1.8 V	Output	FSA [12]
T12	1.8 V	Output	FSA [13]
M11	1.8 V	Output	FSA [14]
R12	1.8 V	Output	FSA [15]
N11	1.8 V	Output	FSA [16]
T13	1.8 V	Output	FSA [17]
P11	1.8 V	Output	FSA [18]
R13	1.8 V	Output	FSA [19]
T9	1.8 V	Output	FSA [2]
M12	1.8 V	Output	FSA [20]
R14	1.8 V	Output	FSA [21]
N12	1.8 V	Output	FSA [22]
T15	1.8 V	Output	FSA [23]
P12	1.8 V	Output	FSA [24]
R9	1.8 V	Output	FSA [3]
P9	1.8 V	Output	FSA [4]
T10	1.8 V	Output	FSA [5]
K16	1.8 V	Output	FSA [6]
R10	1.8 V	Output	FSA [7]
M10	1.8 V	Output	FSA [8]
T11	1.8 V	Output	FSA [9]

**Table 2-5.** MAX II Device Pin-Out *(Note 1)* (Part 3 of 8)

MAX II Pin Number	I/O Standard	Signal Direction	Schematic Signal Name
P4	1.8 V	Bidirectional	FSD [0]
R1	1.8 V	Bidirectional	FSD [1]
M6	1.8 V	Bidirectional	FSD [10]
R5	1.8 V	Bidirectional	FSD [11]
P7	1.8 V	Bidirectional	FSD [12]
T5	1.8 V	Bidirectional	FSD [13]
N7	1.8 V	Bidirectional	FSD [14]
R6	1.8 V	Bidirectional	FSD [15]
M7	1.8 V	Bidirectional	FSD [16]
T6	1.8 V	Bidirectional	FSD [17]
J15	1.8 V	Bidirectional	FSD [18]
R7	1.8 V	Bidirectional	FSD [19]
P5	1.8 V	Bidirectional	FSD [2]
P8	1.8 V	Bidirectional	FSD [20]
T7	1.8 V	Bidirectional	FSD [21]
N8	1.8 V	Bidirectional	FSD [22]
R8	1.8 V	Bidirectional	FSD [23]
F12	1.8 V	Bidirectional	FSD [24]
D16	1.8 V	Bidirectional	FSD [25]
F13	1.8 V	Bidirectional	FSD [26]
D15	1.8 V	Bidirectional	FSD [27]
F14	1.8 V	Bidirectional	FSD [28]
D14	1.8 V	Bidirectional	FSD [29]
T2	1.8 V	Bidirectional	FSD [3]
E12	1.8 V	Bidirectional	FSD [30]
C15	1.8 V	Bidirectional	FSD [31]
N5	1.8 V	Bidirectional	FSD [4]
R3	1.8 V	Bidirectional	FSD [5]
P6	1.8 V	Bidirectional	FSD [6]
R4	1.8 V	Bidirectional	FSD [7]
N6	1.8 V	Bidirectional	FSD [8]
T4	1.8 V	Bidirectional	FSD [9]
F7	GNDINT	Gnd	—
G6	GNDINT	Gnd	—
H7	GNDINT	Gnd	—
H9	GNDINT	Gnd	—
J8	GNDINT	Gnd	—
J10	GNDINT	Gnd	—
K11	GNDINT	Gnd	—

Table 2-5. MAX II Device Pin-Out (Note 1) (Part 4 of 8)

MAX II Pin Number	I/O Standard	Signal Direction	Schematic Signal Name
L10	GNDINT	Gnd	—
A1	GNDIO	Gnd	—
A16	GNDIO	Gnd	—
B2	GNDIO	Gnd	—
B15	GNDIO	Gnd	—
G7	GNDIO	Gnd	—
G8	GNDIO	Gnd	—
G9	GNDIO	Gnd	—
G10	GNDIO	Gnd	—
K7	GNDIO	Gnd	—
K8	GNDIO	Gnd	—
K9	GNDIO	Gnd	—
K10	GNDIO	Gnd	—
R2	GNDIO	Gnd	—
R15	GNDIO	Gnd	—
T1	GNDIO	Gnd	—
T16	GNDIO	Gnd	—
J13	1.8 V	Input	HSMA_BYPASS
M4	2.5 V	Output	HSMA_JTAG_TDI
K4	2.5 V	Input	HSMA_JTAG_TDO
H16	1.8 V	Input	HSMB_BYPASS
H1	2.5 V	Output	HSMB_JTAG_TDI
B9	2.5 V	Input	HSMB_JTAG_TDO
E16	1.8 V	Input	JTAG_SEL
D9	2.5 V	Output	LCD_BS1
N16	1.8 V	Output	LCD_SERn
L16	1.8 V	Input	MAX_CS <sub>n</sub>
N14	1.8 V	Input	MAX_DIP[0]
M13	1.8 V	Input	MAX_DIP[1]
N15	1.8 V	Input	MAX_DIP[2]
L14	1.8 V	Input	MAX_DIP[3]
J5	2.5 V	Output	MAX_EMB
M8	1.8 V	Input	MAX_EN
J4	2.5 V	Output	MAX_ERROR
J3	2.5 V	Output	MAX_FACTORY
K1	2.5 V	Output	MAX_LOAD
K13	1.8 V	Input	MAX_OE <sub>n</sub>
M14	1.8 V	Input	MAX_RESERVE[0]
P14	1.8 V	Input	MAX_RESERVE[1]

**Table 2-5.** MAX II Device Pin-Out (Note 1) (Part 5 of 8)

MAX II Pin Number	I/O Standard	Signal Direction	Schematic Signal Name
K2	2.5 V	Output	MAX_USER
K15	1.8 V	Input	MAX_WEn
H12	1.8 V	Input	MAX2_CLK
M1	2.5 V	Input	MAXGP_JTAG_TCK
L4	2.5 V	Output	MAXGP_JTAG_TDI
L5	2.5 V	Input	MAXGP_JTAG_TDO
M2	2.5 V	Input	MAXGP_JTAG_TMS
N13	1.8 V	Input	MWATTS_MAMPS
H13	1.8 V	Input	PGM [0]
H15	1.8 V	Input	PGM [1]
H14	1.8 V	Input	PGM [2]
G16	1.8 V	Input	PGM [3]
J1	2.5 V	Output	PMON_CLK
J2	2.5 V	Output	PMON_CSN
H3	2.5 V	Bidir	PMON_DATA
H4	2.5 V	Output	PMON_SDI
H5	2.5 V	Output	PMON_SYNC
F6	2.5 V	Output	PWR_DIG_SEL [1]
F1	2.5 V	Output	PWR_DIG_SEL [2]
G3	2.5 V	Output	PWR_DIG_SEL [3]
G2	2.5 V	Output	PWR_DIG_SEL [4]
D2	2.5 V	Output	PWR_SEG_A
E5	2.5 V	Output	PWR_SEG_B
D1	2.5 V	Output	PWR_SEG_C
F3	2.5 V	Output	PWR_SEG_D
F5	2.5 V	Output	PWR_SEG_DP
E2	2.5 V	Output	PWR_SEG_E
F4	2.5 V	Output	PWR_SEG_F
E1	2.5 V	Output	PWR_SEG_G
F2	2.5 V	Output	PWR_SEG_MINUS
G4	2.5 V	Input	PWR_SEL [0]
G1	2.5 V	Input	PWR_SEL [1]
G5	2.5 V	Input	PWR_SEL [2]
H2	2.5 V	Input	PWR_SEL [3]
D13	—	—	RESERVED_INPUT
E14	—	—	RESERVED_INPUT
E15	—	—	RESERVED_INPUT
G12	—	—	RESERVED_INPUT
G14	—	—	RESERVED_INPUT

Table 2-5. MAX II Device Pin-Out (Note 1) (Part 6 of 8)

MAX II Pin Number	I/O Standard	Signal Direction	Schematic Signal Name
G15	—	—	RESERVED_INPUT
K12	—	—	RESERVED_INPUT
L13	—	—	RESERVED_INPUT
P13	—	—	RESERVED_INPUT
R16	—	Input	RESET_CONFIGn
F16	—	Output	SRAM_ACTIVE
F15	—	Input	SRAM_CSn
B3	2.5 V	Input	USB_CLKOUT
E10	2.5 V	Input	USB_CMD_DATA
B10	2.5 V	Output	USB_EMPTY
E9	2.5 V	Bidirectional	USB_FD[0]
A9	2.5 V	Bidirectional	USB_FD[1]
A8	2.5 V	Bidirectional	USB_FD[2]
B8	2.5 V	Bidirectional	USB_FD[3]
E8	2.5 V	Bidirectional	USB_FD[4]
A7	2.5 V	Bidirectional	USB_FD[5]
D8	2.5 V	Bidirectional	USB_FD[6]
B7	2.5 V	Bidirectional	USB_FD[7]
C9	2.5 V	Output	USB_FULLL
J14	1.8 V	Input	USB_IFCLK
A2	2.5 V	Bidirectional	USB_PA0_INT0n
D5	2.5 V	Bidirectional	USB_PA1_INT1n
B1	2.5 V	Bidirectional	USB_PA2_SLOE
D4	2.5 V	Bidirectional	USB_PA3_WU2
L3	2.5 V	Bidirectional	USB_PA4_IF0ADR0
L1	2.5 V	Bidirectional	USB_PA5_IF0ADR1
K5	2.5 V	Bidirectional	USB_PA6_PKTEND
L2	2.5 V	Bidirectional	USB_PA7_SLCSn
A4	2.5 V	Input	USB_PHY_CMD_DATA
D6	2.5 V	Output	USB_PHY_EMPTY
C13	2.5 V	Bidirectional	USB_PHY_FD[0]
B16	2.5 V	Bidirectional	USB_PHY_FD[1]
E11	2.5 V	Bidirectional	USB_PHY_FD[10]
B12	2.5 V	Bidirectional	USB_PHY_FD[11]
C10	2.5 V	Bidirectional	USB_PHY_FD[12]
A12	2.5 V	Bidirectional	USB_PHY_FD[13]
D10	2.5 V	Bidirectional	USB_PHY_FD[14]
B11	2.5 V	Bidirectional	USB_PHY_FD[15]
C12	2.5 V	Bidirectional	USB_PHY_FD[2]

**Table 2-5.** MAX II Device Pin-Out (Note 1) (Part 7 of 8)

MAX II Pin Number	I/O Standard	Signal Direction	Schematic Signal Name
A15	2.5 V	Bidirectional	USB_PHY_FD [3]
D12	2.5 V	Bidirectional	USB_PHY_FD [4]
B14	2.5 V	Bidirectional	USB_PHY_FD [5]
C11	2.5 V	Bidirectional	USB_PHY_FD [6]
B13	2.5 V	Bidirectional	USB_PHY_FD [7]
D11	2.5 V	Bidirectional	USB_PHY_FD [8]
A13	2.5 V	Bidirectional	USB_PHY_FD [9]
C4	2.5 V	Output	USB_PHY_FULLL
C7	2.5 V	Input	USB_PHY_IFCLK
E6	2.5 V	Input	USB_PHY_REn
B4	2.5 V	Input	USB_PHY_WEn
E7	2.5 V	Input	USB_PWR_ENn
C8	2.5 V	Output	USB_RDn
A11	2.5 V	Input	USB_REn
C6	2.5 V	Output	USB_RESETn
A5	2.5 V	Output	USB_RSTn
D7	2.5 V	Input	USB_RSTOUTn
B6	2.5 V	Input	USB_RXFn
B5	2.5 V	Output	USB_SI_WU
K3	2.5 V	Input	USB_TXEn
C5	2.5 V	Output	USB_WAKEUP
M3	2.5 V	Input	USB_WEn
A6	2.5 V	Output	USB_WR
F10	—	Power	VCCINT
G11	—	Power	VCCINT
H8	—	Power	VCCINT
H10	—	Power	VCCINT
J7	—	Power	VCCINT
J9	—	Power	VCCINT
K6	—	Power	VCCINT
L7	—	Power	VCCINT
C1	—	Power	VCCIO1
H6	—	Power	VCCIO1
J6	—	Power	VCCIO1
P1	—	Power	VCCIO1
A3	—	Power	VCCIO2
A14	—	Power	VCCIO2
F8	—	Power	VCCIO2
F9	—	Power	VCCIO2

**Table 2-5.** MAX II Device Pin-Out (Note 1) (Part 8 of 8)

MAX II Pin Number	I/O Standard	Signal Direction	Schematic Signal Name
C16	—	Power	VCCIO3
H11	—	Power	VCCIO3
J11	—	Power	VCCIO3
P16	—	Power	VCCIO3
L8	—	Power	VCCIO4
L9	—	Power	VCCIO4
T3	—	Power	VCCIO4
T14	—	Power	VCCIO4
P15	1.8 V	Input	VOLTS_WATTS

**Note to Table 2-5:**

(1) For more information about the MAX II pin-out, refer to the Altera website at [www.altera.com/literature/lit-dp.jsp](http://www.altera.com/literature/lit-dp.jsp).

Table 2-6 lists the MAX II component reference and manufacturing information.

**Table 2-6.** MAX II Component Reference and Manufacturing Information

Board Reference	Description	Manufacturer	Manufacturing Part Number	Manufacturer Website
U7	256-pin device in a FineLine Ball Grid Array (FBGA) package	Altera Corporation	EPM2210GF256C3N	<a href="http://www.altera.com">www.altera.com</a>

## Configuration, Status, and Setup Elements

This section describes the board's configuration, status, and setup elements, and is divided into the following groups:

- “Configuration” on page 2-15
  - FPGA programming over USB
  - FPGA programming from flash memory
  - Flash programming over USB
- “Status Elements” on page 2-17
  - Board-specific LEDs
  - Power display
- “Setup Elements” on page 2-18
  - JTAG control DIP switch
  - MAX II device control DIP switch
  - System reset and configuration push buttons
  - POWER SELECT rotary switch
  - PGM CONFIG SELECT rotary switch
  - Speaker header



## Configuration

This section discusses FPGA, flash memory, and MAX II device programming methods supported by the Cyclone III development board.

### FPGA Programming Over USB

The FPGA can be configured at any time the board is powered on by using the USB 2.0 interface and the Quartus II Programmer in JTAG mode.

The JTAG chain is mastered by the embedded USB Blaster function found in the MAX II device. Only a USB cable is needed to program the Cyclone III FPGA. Any device can be bypassed by using the appropriate switch on the JTAG control DIP switch.

 Board reference SW1 position 5 (SW1.5), labeled MAX0, must be in the closed position (on) for this feature to properly work. If the SW1 switch is in the closed position, the parallel flash loader (PFL) megafunction in the MAX II CPLD may try to overwrite the FPGA image just downloaded over the USB immediately after completion.

For more information about:

- Advanced JTAG settings, refer to [Table 2-7](#).
- The JTAG control switch, refer to “[JTAG Control DIP Switch](#)” on page 2-19.

**Figure 2-4.** JTAG Chain with the MAX II Device and the Cyclone III Device

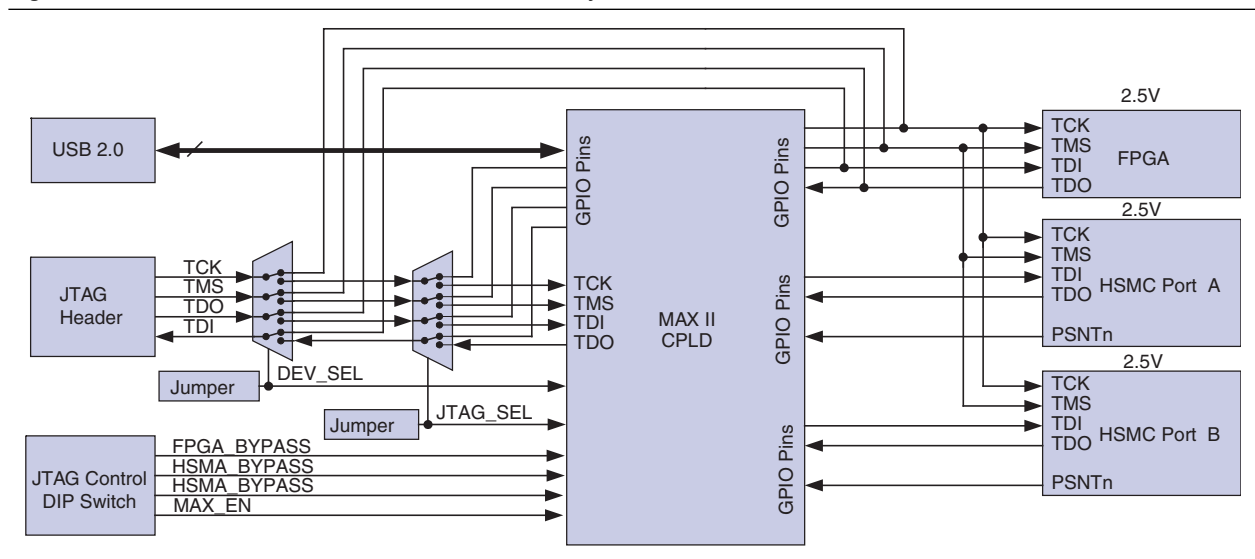

The JTAG header can be used with an external USB-Blaster cable, or equivalent, to program either the MAX II CPLD or configure the Cyclone III FPGA. Most users of the Cyclone III development board do not use the JTAG header at all and instead use a USB cable along with the embedded USB-Blaster. Using an external USB-Blaster with the JTAG header requires disabling the embedded USB-Blaster function. See [Table 2-7](#).

**Table 2-7.** JTAG Settings (Note 1)

Number	Description	FPGA Bypass (SW3.1)	HSMA Bypass (SW3.2)	HSMB Bypass (SW3.3)	MAX Enable (SW3.4)	PFL Enable (SW1.5 MAX0)	Device Select (DEV_SEL) Jumper, J6
1	Embedded USB Blaster (2), Cyclone III target device only	1	0	0	0	1	X
2	Embedded USB Blaster (2), (4) Cyclone III device + HSMC Port A	1	1	0	0	1	X
3	Embedded USB Blaster (2), (4) Cyclone III device + HSMC Port B	1	0	1	0	1	X
4	External USB Blaster (3), Cyclone III target device only	X	X	X	1	1	Off
5	External USB Blaster (3), MAX II target device only	X	X	X	X	X	On

**Notes to Table 2-7:**

- (1) The nomenclature SW3.1 is used to indicate board reference SW3, position 1; similarly SW1.5 is used to indicate board reference SW1, position 5.
- (2) Requires USB cable plugged into board reference J3.
- (3) Requires external USB-Blaster or equivalent plugged into board reference J14 (PCB bottom).
- (4) The JTAG chains for both HSMC ports A and B can only be accessed from the embedded USB-Blaster. They cannot be accessed from the external USB-Blaster header.

**FPGA Programming from Flash Memory**

On either power-up or by pressing the RESET\_CONFIG or FACTORY\_CONFIG push button, the MAX II CPLD device's PFL megafunction configures the Cyclone III FPGA from flash memory.

The PFL megafunction reads 16-bit data from the flash memory and converts it to passive serial format. The data is written to the Cyclone III device's dedicated DCLK and D0 configuration pins at 12 MHz.

FPGA configuration from flash memory can be sourced from one of eight images. The image is selected by the PGM\_CONFIG\_SELECT rotary switch, board reference SW5. The rotary switch has 16 positions, but only the first eight are used. The positions correspond to an offset in flash memory that the PFL is directed to for FPGA configuration data.



Board reference SW1 position 5 (SW1.5), labeled MAX0, must be in the open position (1) for this feature to be enabled. If the SW1 switch is in the closed (0) position, the PFL megafunction in the MAX II CPLD is disabled.

### Flash Programming over USB Interface

The flash memory can be programmed at any time the board is powered up by using the USB 2.0 interface and the Quartus II Programmer’s JTAG mode.

The development kit implements the Altera PFL megafunction for flash programming. The PFL is a block of logic that is programmed into an Altera programmable logic device (FPGA or CPLD). The PFL functions as a utility for writing to a compatible flash device. The development kit ships with a pre-built PFL design called `cycloneIII_3c120_dev_pfl`. The PFL design is programmed onto the FPGA whenever the flash is to be written using the Quartus II software.

 For more information about:

- PFL megafunction, refer to *AN386: Using the Parallel Flash Loader with the Quartus II Software*.
- Basic flash programming instructions for the development board, refer to the *Programming the Flash Device* section of the *Cyclone III Development User Guide*.

### Status Elements

The development board includes general user, board specific, and HSMC user LEDs. This section discusses board-specific LEDs as well as the power display device.

 For information about general and HSMC user-defined LEDs, refer to “User-Defined LEDs” on page 2-27.

#### Board Specific LEDs

There are 14 board-specific LEDs, which are factory designated. Table 2-8 lists the LED board reference, name, and description.

**Table 2-8.** Board-Specific LEDs (Part 1 of 2)

Board Reference	LED Name	Description
D5	Power	Illuminates when board power switch SW2 is on. (Requires 14 V to 20 V input to DC input jack J2)
D25	CONF DONE	Illuminates when FPGA is successfully configured. Driven by Cyclone III FPGA.
D20	Loading	Illuminates when MAX II CPLD is actively configuring the FPGA. Driven by the MAX II CPLD.
D21	Error	Illuminates when MAX II CPLD fails to successfully configure the FPGA. Driven by the MAX II CPLD.
D24	Factory	Illuminates when FPGA is configured with the default factory FPGA design. Driven by the MAX II CPLD.
D22	User	Illuminates when FPGA is configured with a design other than the default factory FPGA design. Driven by the MAX II CPLD.
D7	ENET TX	Illuminates when transmit data is active from the Ethernet PHY. Driven by the Marvell 88E1111 PHY.
D8	ENET RX	Illuminates when receive data is active from the Ethernet PHY. Driven by the Marvell 88E1111 PHY.

**Table 2-8.** Board-Specific LEDs (Part 2 of 2)

Board Reference	LED Name	Description
D1	10 MB	Illuminates when Ethernet PHY is using the 10 Mbps connection speed. Driven by the Marvell 88E1111 PHY.
D3	100 MB	Illuminates when Ethernet PHY is using the 100 Mbps connection speed. Driven by the Marvell 88E1111 PHY.
D4	1000 M	Illuminates when Ethernet PHY is using the 1000 Mbps connection speed. Driven by the Marvell 88E1111 PHY. Also connects to Cyclone III FPGA.
D6	Duplex	Illuminates when Ethernet PHY is both sending and receiving data. Driven by the Marvell 88E1111 PHY.
D18	HSMC Port A present	Illuminates when HSMC Port A has a board or cable plugged such that pin 160 becomes grounded.
D19	HSMC Port B present	Illuminates when HSMC Port B has a board or cable plugged such that pin 160 becomes grounded.
D17	SRAM active	Illuminates when SRAM is being accessed with a read or write transaction. Driven by the MAX II CPLD.
D23	Flash active	Illuminates when flash memory is being accessed with a read or write transaction. Driven by the MAX II CPLD.

Table 2-9 lists the board-specific LEDs component reference and manufacturing information.

**Table 2-9.** Board-Specific LEDs Component Reference and Manufacturing Information

Board Reference	Description	Manufacturer	Manufacturing Part Number	Manufacturer Website
D1, D3, D4, D6-D8, D17-D19, D20, D22-D25	Green LED, 1206, SMT, clear lens, 2.1 V	Lumex, Inc	SML-LX1206GC-TR	<a href="http://www.lumex.com">www.lumex.com</a>
D5	Blue LED, 1206, SMT, clear lens, 3.5 V	Lumex, Inc	SML-LX1206USBC-TR	<a href="http://www.lumex.com">www.lumex.com</a>
D21	Red LED, 1206, SMT, clear lens, 2.0 V	Lumex, Inc	SML-LX1206IC-TR	<a href="http://www.lumex.com">www.lumex.com</a>

### Power Display (U28)

The power being measured by the MAX II CPLD and associated A/D is displayed on a dedicated 7-segment display connected to the MAX II device called *Power Display*. Although the 7-segment display is connected to the MAX II CPLD, it is also register-controllable from the FPGA using the FSM bus.

## Setup Elements

The development board includes user, JTAG control, and board-specific DIP switches. The board also includes system reset and configuration push button switches as well as rotary switches. This section discusses:

- JTAG control DIP switch
- MAX II device control DIP switch
- System reset and configuration push buttons

- POWER SELECT rotary switch
- PGM CONFIG SELECT rotary switch
- Speaker header

### JTAG Control DIP Switch

Board reference SW3 is a 4-position JTAG control DIP switch, and it is provided to either remove or include devices in the active JTAG chain. Additionally, JTAG control DIP switch is also used to disable the embedded USB-Blaster cable when using an external USB-Blaster cable (Table 2-10).

**Table 2-10.** JTAG Control DIP Switch Signal Name and Description

DIP Switch	Signal Name	Description
SW3.1	FPGA_BYPASS	Includes or removes FPGA from embedded USB-Blaster JTAG chain. 1 – FPGA included in JTAG chain 0 – FPGA not included in JTAG chain
SW3.2	HSMA_BYPASS	Includes or removes HSMA Port from embedded USB-Blaster JTAG chain. 1 – HSMA Port included in JTAG chain 0 – HSMA Port not included in JTAG chain
SW3.3	HSMB_BYPASS	Includes or removes HSMB Port from embedded USB-Blaster JTAG chain. 1 – HSMB Port included in JTAG chain 0 – HSMB Port not included in JTAG chain
SW3.4	MAX_EN	Enables embedded USB-Blaster JTAG chain. 1 – Embedded USB-Blaster connected to JTAG chain 0 – Embedded USB-Blaster disconnected from JTAG chain

Because the JTAG chain also contains the two HSMC, the SW3 DIP switch allows data to bypass the HSMC interfaces as well as the MAX II CPLD. See “FPGA Programming Over USB” on page 2-15.

 For information about user-defined DIP switches, refer to “User-Defined DIP Switches” on page 2-27.

Table 2-11 lists the JTAG control switch component reference and manufacturing information.

**Table 2-11.** JTAG Control Switch Component Reference and Manufacturing Information

Board Reference	Description	Manufacturer	Manufacturing Part Number
SW3	Four-position slider DIP switch	C&K Components ITT industries	TDA04H0SB1

### MAX II Device Control DIP Switch

Board reference SW1 is the board settings DIP switch, which controls various features specific to the Cyclone III development board and factory default (board test system) FPGA design: On = logic 0 and Off = logic 1.

Table 2-12 lists the switch position, name, and description.

**Table 2-12.** MAX II Device Control DIP Switch Position, Name, and Description

Switch	Name	Description
8	MAX3	Reserved
7	MAX2	Reserved
6	MAX1	Reserved
5	MAX0	open (1) = MAX II device PFL enabled, closed (0) = MAX II device PFL disabled
4	MAX_RESERVE1	Reserved
3	MAX_RESERVE0	Reserved
2	VOLTS_WATTS	1 = power display shows mW/mA, 0 = power display shows voltage
1	MWATTS_MAMPS	1 = power display shows mA, 0 = power display shows mW

Table 2-13 lists the MAX II device control DIP switch component reference and manufacturing information.

**Table 2-13.** MAX II Device Control DIP Switch Component Reference and Manufacturing Information

Board Reference	Description	Manufacturer	Manufacturing Part Number	Manufacturer Website
SW1	8-position rocker DIP switch	Grayhill Corporation	76SB08ST	<a href="http://www.grayhill.com">www.grayhill.com</a>

### System Reset and Configuration Switches

Board reference S6 is the system reset push button switch, RESET\_CONFIGn, which is an input to the MAX II device. It forces a reconfiguration of the FPGA from flash memory. The location in flash memory is based on the input from the board settings rotary switch position for the signals PGM [2 : 0]. The MAX II device uses the RESET\_CONFIGn pin as its reset along with the CPU\_RESEtn push button.

Board reference S5 is the CPU reset push button switch, CPU\_RESET, which is an input to both the Cyclone III FPGA and the MAX II CPLD. The CPU\_RESET push button is intended to be the master reset signal for the FPGA design loaded in the Cyclone III device, and connects to the special function pin called DEV\_CLR on the FPGA but is also a regular I/O pin. The MAX II device uses this as its reset along with the RESET\_CONFIG and FACTORY\_CONFIG push buttons.

Board reference S7 is the factory push button switch (FACTORY\_CONFIG), which is an input to the MAX II device. The FACTORY\_CONFIG pin forces a reconfiguration of the FPGA with the factory default FPGA design, which is located at the base of flash memory. See Table 2-14.

**Table 2-14.** Push Button Switch Signal Name and Function

Board Reference	Description	I/O Standard	Schematic Signal Name	Cyclone III Device Pin Number	MAX II Device Pin Number
S7	User defined push button	1.8 V	FACTORY_CONFIG	—	A10
S6	User defined push button	1.8 V	RESET_CONFIGn	—	R16
S5	User defined push button	1.8 V	CPU_RESET	T21	M9

Table 2-15 lists the push-button switch component reference and manufacturing information.

**Table 2-15.** Push-Button Switch Component Reference and Manufacturing Information

Board Reference	Description	Manufacturer	Manufacturing Part Number	Manufacturer Website
S5-S7	Push button switch	Panasonic	EVQAPAC07K	<a href="http://www.panasonic.com">www.panasonic.com</a>

 For information about user-defined push buttons, refer to “User-Defined Push Button Switches” on page 2-26.

### POWER SELECT Rotary Switch

A 16-position rotary switch, board reference SW4, is used to select the current power rail whose power is being measured and displayed on the power display. The rotary switch is connected to the MAX II CPLD, but it also registers readable by the FPGA using the FSM shared bus (flash, SRAM, and MAX II device). Table 2-16 lists the power select rotary switch number, name, power pin, and description.

**Table 2-16.** Power Select Rotary Switch Number, Name, Pin, and Description (Part 1 of 2)

Number	Schematic Signal Name	Power Pin Name	Description
0	1.2V_INT	VCCINT	FPGA core power
1	1.2V_VCCD	VCCD_PLL	FPGA PLL digital power
2	2.5V_VCCA	VCCA	FPGA PLL analog power and auxiliary circuit power
3	1.8V_IO_B3_B4	VCCIO3, VCCIO4	FPGA I/O power banks 3, 4
4	1.8V_IO_B7_B8	VCCIO7, VCCIO8	FPGA I/O power banks 7, 8
5	2.5V_IO_B1_B2	VCCIO1, VCCIO2	FPGA I/O power banks 1, 2
6	2.5V_IO_B5_B6	VCCIO5, VCCIO6	FPGA I/O power banks 5, 6
7	1.2V	—	All non-FPGA 1.2-V power (Ethernet)
8	1.8V	—	All non-FPGA 1.8-V power (SRAM, Flash, MAX II, and DDR2 devices)
9	2.5V	—	All non-FPGA 2.5-V power (Ethernet, LEDs, LCD)
A	3.3V	—	All 3.3-V power (voltage only) (1)
B	5.0V	—	All 5.0-V power (voltage only) (1)

**Table 2-16.** Power Select Rotary Switch Number, Name, Pin, and Description (Part 2 of 2)

Number	Schematic Signal Name	Power Pin Name	Description
C	12V	—	All 12-V power (voltage only) (1)
D	—	—	—
E	—	—	—
F	—	—	—

**Note to Table 2-16:**

- (1) Display shows resistor divider output, not actual voltage as the A/D cannot take in sources higher than 3.0 V. See schematic page 5 for resistor dividers. Current (mA) displays for these voltages are only accurate to see a change in current from one circuit state to another. The absolute current levels should not be referenced.

Table 2-17 lists power select rotary switch component reference and manufacturing information.

**Table 2-17.** Power Select Rotary Switch Component Reference and Manufacturing Information

Board Reference	Description	Manufacturer	Manufacturing Part Number	Manufacturer Website
SW4	16-position rotary switch	Grayhill Corporation	94HCB16WT	<a href="http://www.grayhill.com">www.grayhill.com</a>

**PGM CONFIG SELECT Rotary Switch**

A 16-position rotary switch, board reference SW5, is used to select the location in flash memory to load the Cyclone III FPGA design. The rotary switch has 16 positions but only the first eight are used. For information about the flash memory locations, refer to Table 2-58 on page 2-60.

Table 2-18 lists PGM configuration select rotary switch component reference and manufacturing information.

**Table 2-18.** PGM CONFIG SELECT Rotary Switch Component Reference and Manufacturing Information

Board Reference	Description	Manufacturer	Manufacturing Part Number	Manufacturer Website
SW5	Rotary switch	Grayhill Corporation	94HCB16WT	<a href="http://www.grayhill.com">www.grayhill.com</a>

**Speaker Header (J5)**

A four-pin 0.1" pitch header is used for a PC speaker connection. The FPGA drives an R/C filter from a 2.5-V CMOS I/O pin allowing tones to be generated by driving different frequencies to the pin.

Table 2-19 lists power select rotary switch component reference and manufacturing information.

**Table 2-19.** Power Select Rotary Switch Component Reference and Manufacturing Information

Board Reference	Description	Manufacturer	Manufacturing Part Number	Manufacturer Website
J5	Speaker header	Samtec	TSW-104-07-G-S	<a href="http://www.samtec.com">www.samtec.com</a>



## Clocking Circuitry

This section describes Cyclone III FPGA clocking inputs and outputs. A diagram is provided for each section.

### Cyclone III FPGA Clock Inputs

Figure 2-5 outlines the clocking inputs to the Cyclone III FPGA.

 Some signals are connected to 1.8-V banks and some are connected to 2.5-V banks. Refer to the *Cyclone III Device Handbook* for information about allowable levels for driving these inputs from external sources.

The clock 1 and clock 2 signals from the HSMC interface can be used as LVDS pairs or as eight separate clock signals. These signals include HSMA\_CLK\_IN\_P2/N2, HSMA\_CLK\_IN\_P1/N1, HSMB\_CLK\_IN\_P2/N2, and HSMB\_CLK\_IN\_P1/N1. These signals may also be used for bidirectional data. If used in LVDS mode, install applicable termination resistors between P/N pairs. A voltage translator, National Semiconductor part number FXLP34, is located in between the HSMC interfaces and the Cyclone III FPGA to reduce LVTTTL to 1.8-V CMOS input levels for clock 0 signals HSMA\_CLK\_IN0 and HSMB\_CLK\_IN0.



 For more information, refer to the Cyclone III development board schematics included in the development kit.

Figure 2-5. Cyclone III FPGA Clock Inputs

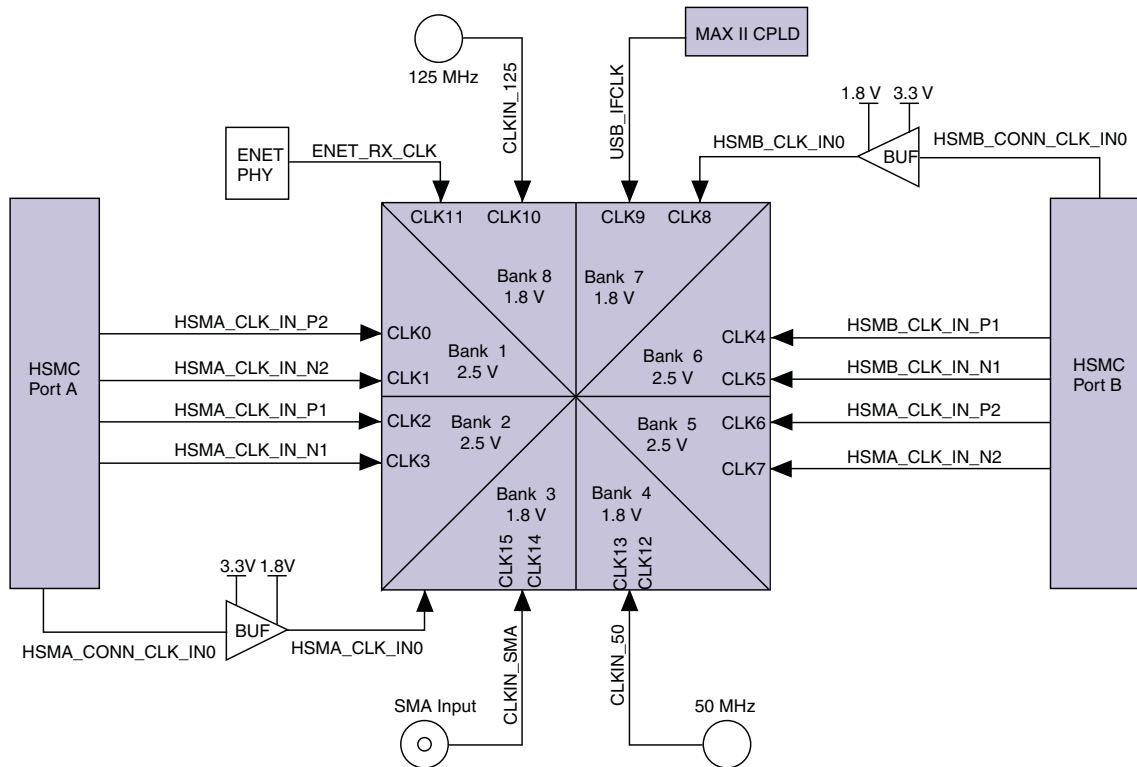

## Cyclone III FPGA Clock Outputs

Figure 2-6 outlines the clocking outputs from the Cyclone III FPGA.

 Some signals are connected to 1.8-V banks and some are connected to 2.5-V banks. Refer to the *Cyclone III Device Handbook* for information about voltage output levels.

The clock 1 and clock 2 signals from the HSMC interface can be used as LVDS pairs or as eight separate clock signals. These signals include HSMA\_CLK\_IN\_P2/N2, HSMA\_CLK\_IN\_P1/N1, HSMB\_CLK\_IN\_P2/N2, and HSMB\_CLK\_IN\_P1/N1. These signals may also be used for bidirectional data.

The CLKOUT\_SMA signal connects to the Cyclone III FPGA using a dedicated PLL output pin, PLL4\_CLKOUTp. This pin does not have to be used with the PLL as it can also drive data or other trigger signals.

**Figure 2-6.** Cyclone III FPGA Clock Outputs

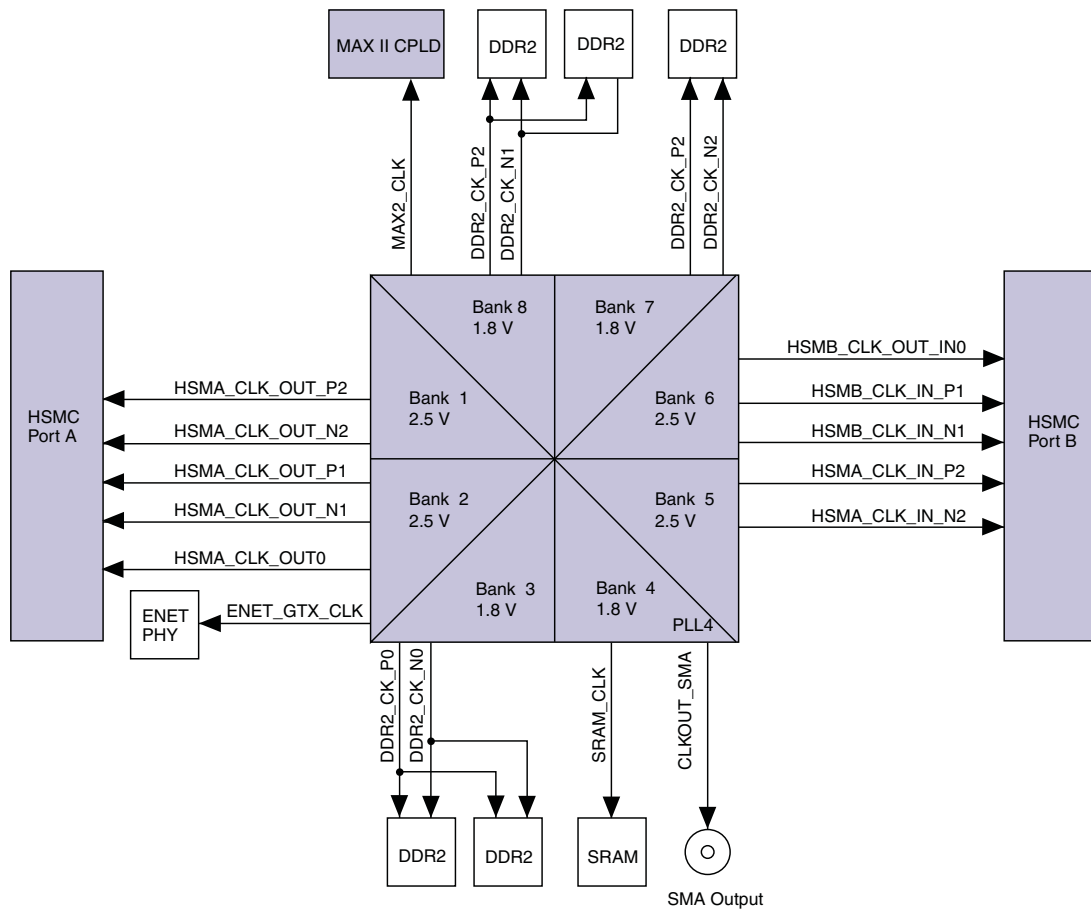

Table 2-20 shows the clocking parts list.

**Table 2-20.** Cyclone III Development Board Clocking Parts List

Board Reference	Description	Manufacturer	Manufacturer Part Number	Manufacturer Website
Y5	50-MHz LVDS oscillator	Pletronics	SM5545TEX-50.00M	<a href="http://www.pletronics.com">www.pletronics.com</a>
Y4	125-MHz LVDS oscillator	Pletronics	SM5545TEX-125.00M	<a href="http://www.pletronics.com">www.pletronics.com</a>
J10, J11	SMA for external clock input/output	Lighthouse Technologies	LTI-SASF546-P26-X1	<a href="http://www.rfconnector.com">www.rfconnector.com</a>
Y1	24-MHz crystal	Abracon Corporation	ABL-24.000MHZ-12	<a href="http://www.abracon.com">www.abracon.com</a>
Y2	6-MHz crystal	Abracon Corporation	ABL-6.000MHZ-B2	<a href="http://www.abracon.com">www.abracon.com</a>
X1	25-MHz crystal oscillator	ECS, Inc.	ECS-3953C-250-B	<a href="http://www.ecsxtal.com">www.ecsxtal.com</a>
Y3	24-MHz crystal oscillator	Pletronics	SM5545TEX-24.00M	<a href="http://www.pletronics.com">www.pletronics.com</a>

Table 2-21 lists the board’s clock distribution system.

**Table 2-21.** Cyclone III Development Board Clock Distribution

Source	Schematic Signal Name	I/O Standard	Signal Originates From	Signal Propagates To
125-MHz (Y4) oscillator	clk <sub>in</sub> _125	Input	Y4	Cyclone III device pin A14
50-MHz (Y5) oscillator	clk <sub>in</sub> _50	Input	Y5	Cyclone III device pin AH15
User input (SMA clock input)	clk <sub>in</sub> _sma	Input	J10	Cyclone III device pin AH14
User output (SMA clock output)	clk <sub>out</sub> _sma	Output	J11	From Cyclone III device pin AE23
25 MHz (reference clock); This clock can change both speed and direction depending on the Ethernet link speed (10/100/1000)	enet_rx_clk	Input	U5	Cyclone III device pin B14
24-MHz (Y3) oscillator	clk <sub>in</sub> _24	Input	Y3	MAX II device pin J12 (Bank 3)
6-MHz crystal	XTIN/XTOUT	Input	Y2	FTDI USB PHY
24-MHz crystal	XTALIN/XTALOUT	Input	Y1	Cypress USB PHY

## Oscillators

There are several on-board crystals and crystal oscillators driving reference clocks to different devices. Table 2-22 lists the board’s oscillators.

**Table 2-22.** Board Oscillators

Number	Frequency	Description
1	6.000 MHz	Crystal for FTDI USB PHY
2	24.000 MHz	Crystal for Cypress USB PHY
3	24.000 MHz	Crystal oscillator for MAX II CPLD
4	25.000 MHz	Crystal oscillator for Ethernet PHY
5	50.000 MHz	Crystal oscillator for Cyclone III FPGA PLL
6	125.000 MHz	Crystal oscillator for Cyclone III FPGA PLL

## General User Interfaces

To allow you to fully leverage the I/O capabilities of the Cyclone III device for debugging, control, and monitoring purposes, the following general user interfaces are available on the board:

- Push buttons
- DIP switches
- LEDs
- 7-segment displays
- LCD displays

### User-Defined Push Button Switches

The development board includes four general user, one user reset, one system reset, and one factory push button switch.

 For information on the system reset and factory push button switches, refer to “[System Reset and Configuration Switches](#)” on page 2-20.

Board references S1 through S4 are push button switches allowing general user I/O interfaces to the Cyclone III device. There is no board-specific function for these four push buttons.

Board reference S5 is the user reset push button switch, CPU\_RESETn, which is an input to the Cyclone III device and MAX II CPLD. It is intended to be the master reset signal for the FPGA design loaded into the Cyclone III device. This connects to the special function pin called the DEV\_CLR on the FPGA, but it also is a regular I/O pin. The MAX II device uses the DEV\_CLR pin as its reset along with the RESET\_CONFIGn push button.

Table 2-23 lists the schematic signal name and corresponding Cyclone III pin number.

**Table 2-23.** Push Button Switch Signal Name and Function

Board Reference	Schematic Signal Name	Cyclone III Device Pin Number	MAX II Device Pin Number
S1	USER_PB3	AA12	—
S2	USER_PB2	AH3	—
S3	USER_PB1	AC12	—
S4	USER_PB0	AD7	—
S5	CPU_RESETn	T21	M9

Table 2-24 lists the push button switch component reference and manufacturing information.

**Table 2-24.** Push Button Switch Component Reference and Manufacturing Information

Board Reference	Description	Manufacturer	Manufacturing Part Number	Manufacturer Website
S1 through S5	Push button switch	Panasonic	EVQPAC07K	<a href="http://www.panasonic.com">www.panasonic.com</a>

## User-Defined DIP Switches

Board reference SW6 is an 8-pin DIP switch. The switches in SW6 are user-defined, and are provided for additional FPGA input control. Each pin can be set to a logic 1 by pushing it to the open position, and each pin can be set to a logic 0 by pushing it to the closed position. There is no board-specific function for these switches.

Table 2-25 lists the user DIP switch setting, schematic signal name, and corresponding Cyclone III device's pin number.

**Table 2-25.** User-Defined DIP Switch Pin-Out (SW6)

Board Reference SW6 DIP Switch	Description	I/O Standard	Schematic Signal Name	Cyclone III Device Pin Number
SW6 pin 1	User-defined DIP switch pin 1	1.8 V	USER_DIPSW0	AC14
SW6 pin 2	User-defined DIP switch pin 2	1.8 V	USER_DIPSW1	AD18
SW6 pin 3	User-defined DIP switch pin 3	1.8 V	USER_DIPSW2	AG23
SW6 pin 4	User-defined DIP switch pin 4	1.8 V	USER_DIPSW3	AC19
SW6 pin 5	User-defined DIP switch pin 5	1.8 V	USER_DIPSW4	AD14
SW6 pin 6	User-defined DIP switch pin 6	1.8 V	USER_DIPSW5	G20
SW6 pin 7	User-defined DIP switch pin 7	1.8 V	USER_DIPSW6	AB15
SW6 pin 8	User-defined DIP switch pin 8	1.8 V	USER_DIPSW7	AF25

Table 2-26 lists the user-defined DIP switch component reference and manufacturing information.

**Table 2-26.** User-Defined DIP Switch Component Reference and Manufacturing Information

Board Reference	Description	Manufacturer	Manufacturing Part Number	Manufacturer Website
SW6	8-position rocker DIP switch	Grayhill Corporation	76SB08ST	<a href="http://www.grayhill.com">www.grayhill.com</a>

## User-Defined LEDs

The board includes general, HSMC, and DDR2 user-defined LEDs. This section discusses all user-defined LEDs.

 For information about board specific or status LEDs, refer to “Status Elements” on page 2-17.

### General User-Defined LEDs

Board references D26 through D33 are eight user LEDs, which allow status and debugging signals to be driven to LEDs from the FPGA designs loaded into the Cyclone III device. There is no board-specific function for these LEDs.

Table 2-27 lists the general user LED reference number, schematic signal name, and corresponding Cyclone III device pin number.

**Table 2-27.** LED Reference Number, Schematic Signal Name, and Cyclone III Device Pin Number

LED Board Reference	Description	I/O Standard	Schematic Signal Name	Cyclone III Device Pin Number
D26	User-defined LED	1.8 V	USER_LED7	AF19
D27	User-defined LED	1.8 V	USER_LED6	AG19
D28	User-defined LED	1.8 V	USER_LED5	AC17
D29	User-defined LED	1.8 V	USER_LED4	AE15
D30	User-defined LED	1.8 V	USER_LED3	AD19
D31	User-defined LED	1.8 V	USER_LED2	AF18
D32	User-defined LED	1.8 V	USER_LED1	AE20
D33	User-defined LED	1.8 V	USER_LED0	AD15

Table 2-28 lists the general user-defined LED component reference and manufacturing information.

**Table 2-28.** General User-Defined LED Component Reference and Manufacturing Information

Board Reference	Description	Manufacturer	Manufacturing Part Number	Manufacturer Website
D26-D33	Green LEDs, 1206, SMT, clear lens, 2.1 V	Lumex, Inc.	SML-LX1206GC-TR	<a href="http://www.lumex.com">www.lumex.com</a>

### HSMC User-Defined LEDs

The HSMC Port A and Port B have two LEDs located nearby. There are no board-specific functions for the HSMC LEDs; however, the HSMC LEDs are labeled TX and RX, and are intended to display data flow to and from connected HSMC daughter cards. The LEDs are driven by the Cyclone III device.

Table 2-29 lists the HSMC user-defined LED board reference number, schematic signal name, and corresponding Cyclone III device pin number.

**Table 2-29.** HSMC User LEDs

Board Reference	Description	I/O Standard	Schematic Signal Name	Cyclone III Device Pin Number
D12	User-defined but labeled <i>TX</i> in silk-screen for HSMC Port A.	1.8 V	HSMA_TX_LED	AA3
D14	User-defined but labeled <i>RX</i> in silk-screen for HSMC Port A.	1.8 V	HSMA_RX_LED	AE1
D13	User-defined but labeled <i>TX</i> in silk-screen for HSMC Port B.	1.8 V	HSMB_TX_LED	D28
D15	User-defined but labeled <i>RX</i> in silk-screen for HSMC Port B.	1.8 V	HSMB_RX_LED	F26

Table 2-30 lists the HSMC user-defined LED component reference and manufacturing information.

**Table 2-30.** HSMC User-Defined LED Component Reference and Manufacturing Information

Board Reference	Description	Manufacturer	Manufacturing Part Number	Manufacturer Website
D12-D15	Green LED, 1206, SMT, clear lens, 2.1 V	Lumex, Inc.	SML-LX1206GC-TR	<a href="http://www.lumex.com">www.lumex.com</a>

## DDR2 User-Defined LEDs

Each channel of DDR2 memory has an LED near the respective DDR2 device. There is no board-specific function for these LEDs; however, they are labeled `DDR2TOP_ACTIVE` and `DDR2BOT_ACTIVE` on the silkscreen and are intended to be illuminated when each respective memory channel is being accessed. The LEDs are driven by the Cyclone III device.

Table 2-31 lists the DDR2 user-defined LED board reference number, schematic signal name, and corresponding Cyclone III device pin number.

**Table 2-31.** DDR2 User—Defined LEDs

Board Reference	Schematic Signal Name	Cyclone III Device Pin Number
D11	<code>DDR2TOP_ACTIVE</code>	User defined but labeled <code>DDR2TOP_ACTIVE</code> on the silkscreen for DDR2TOP memory channel.
D16	<code>DDR2BOT_ACTIVE</code>	User defined but labeled <code>DDR2BOT_ACTIVE</code> in silkscreen for DDR2BOT memory channel.

Table 2-32 lists the memory user-defined LED component reference and manufacturing information.

**Table 2-32.** Memory User-Defined LED Component Reference and Manufacturing Information

Board Reference	Description	Manufacturer	Manufacturing Part Number	Manufacturer Website
D11 and D16	Green LED, 1206, SMT, clear lens 2.1 V	Lumex, Inc.	SML-LX1206GC-TR	<a href="http://www.lumex.com">www.lumex.com</a>

## 7-Segment Displays

This section discusses the following two on-board displays:

- User 7-segment display
- Power 7-segment display

### User 7-Segment Display

Board reference U30 is a four-digit, user-defined, 7-segment display that is labeled User Display. Each segment's LED driver input signals are multiplexed to each of the four digits and a minus sign. A small HDL code snippet continuously writes to each of the four segments so that they appear constantly illuminated.

Table 2-33 lists the 7-segment display pin-out.

**Table 2-33.** 7-Segment Display Pin-Out

Board Reference	Description	I/O Standard	Schematic Signal Name	Cyclone III Device Pin Name
U30 pin 12	User-defined display signal	1.8 V	SEVEN_SEG_A	AD5
U30 pin 11	User-defined display signal	1.8 V	SEVEN_SEG_B	A3
U30 pin 3	User-defined display signal	1.8 V	SEVEN_SEG_C	C4
U30 pin 8	User-defined display signal	1.8 V	SEVEN_SEG_D	D4
U30 pin 9	User-defined display signal	1.8 V	SEVEN_SEG_E	E5
U30 pin 7	User-defined display signal	1.8 V	SEVEN_SEG_F	D5
U30 pin 5	User-defined display signal	1.8 V	SEVEN_SEG_G	AE6
U30 pin 2	User-defined display signal	1.8 V	SEVEN_SEG_DP	AD4
U30 pin 13	User-defined display signal	1.8 V	SEVEN_SEG_SEL1	B3
U30 pin 1	User-defined display select signal	1.8 V	SEVEN_SEG_SEL2	C5
U30 pin 10	User-defined display select signal	1.8 V	SEVEN_SEG_SEL3	E4
U30 pin 4	User-defined display select signal	1.8 V	SEVEN_SEG_SEL4	C3
U30 pin 6	User-defined display select signal	1.8 V	SEVEN_SEG_MINUS	G19



 The four-pin, 7-segment display uses fewer pins than 2-digit, 7-segment displays. See Figure 2-7.

**Figure 2-7.** 7-Segment Display

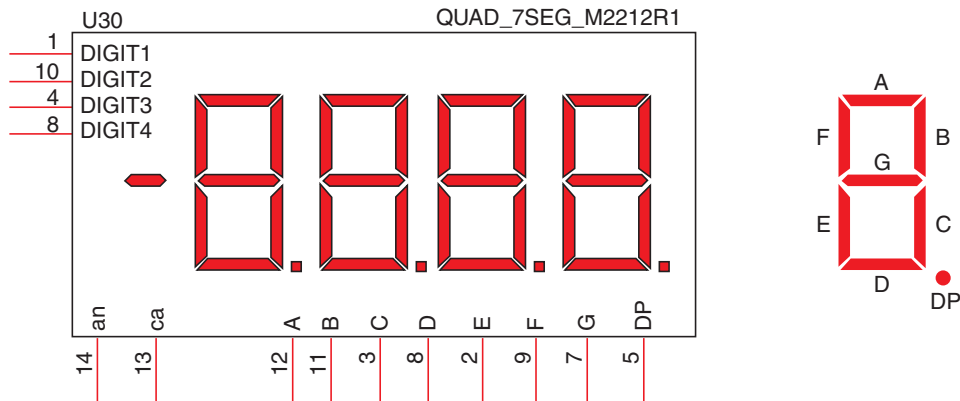

Table 2-34 lists the 7-segment display component reference and manufacturing information.

**Table 2-34.** 7-Segment Display Component Reference and Manufacturing Information

Board Reference	Description	Manufacturer	Manufacturing Part Number	Manufacturer Website
U30	7-segment, green LED display	Lumex, Inc.	LDQ-M2212R1	<a href="http://www.lumex.com">www.lumex.com</a>

### Power 7-Segment Display

The power measured by the MAX II CPLD and associated A/D is displayed on board reference U28, which is a dedicated 7-segment display connected to the MAX II CPLD, labeled *Power Display*.

Table 2-35 lists the power 7-segment display component reference and manufacturing information.

**Table 2-35.** Power 7-Segment Display Component Reference and Manufacturing Information

Board Reference	Description	Manufacturer	Manufacturing Part Number	Manufacturer Website
U28	7-segment, green LED display	Lumex, Inc.	LDQ-M2212R1	<a href="http://www.lumex.com">www.lumex.com</a>

## LCD Information

The development board is designed to accommodate two separate displays:

- Character LCD
- Graphics LCD

The first display is a 16-character, by 2-line LCD display. The second is a 128 × 64 pixel transmissive graphics LCD. These two share a common bus but have separate control signals so they can operate simultaneously. This section describes both displays.

**Character LCD (J4)**

The board contains a single 14-pin 0.1" pitch dual-row header, used to interface to a 16-character by 2-line LCD display, Lumex (part number LCM-S01602DSR/C). The LCD has a 14-pin receptacle that mounts directly to the board's 14-pin header, so it can be easily removed for access to components under the display—or to use the header for debugging or other purposes.

Table 2-36 summarizes the character LCD interface pins. Signal name and direction are relative to the Cyclone III FPGA. For functional descriptions, see Table 2-37.

**Table 2-36.** Character LCD Header I/O

Board Reference	Description	I/O Standard	Schematic Signal Name	Cyclone III Pin Number
J22 pin 7	LCD data bus bit 0	2.5 V	LCD_DATA0	AA4
J22 pin 8	LCD data bus bit 1	2.5 V	LCD_DATA1	AD1
J22 pin 9	LCD data bus bit 2	2.5 V	LCD_DATA2	V8
J22 pin 10	LCD data bus bit 3	2.5 V	LCD_DATA3	AB5
J22 pin 11	LCD data bus bit 4	2.5 V	LCD_DATA4	AE2
J22 pin 12	LCD data bus bit 5	2.5 V	LCD_DATA5	V5
J22 pin 13	LCD data bus bit 6	2.5 V	LCD_DATA6	V6
J22 pin 14	LCD data bus bit 7	2.5 V	LCD_DATA7	AB3
J22 pin 4	LCD data/command select	2.5 V	LCD_D_Cn	D27
J22 pin 5	LCD write enable	2.5 V	LCD_D_WEn	AC4
J22 pin 6	LCD chip select	2.5 V	LCD_D_CSn	AB24

Table 2-37 shows pin definitions, and is an excerpt from the Lumex data sheet.



For more information such as timing, character maps, interface guidelines, and related documentation, visit [www.lumex.com](http://www.lumex.com).

**Table 2-37.** Character LCD Display Pin Definitions

Pin Number	Symbol	Level	Function	
1	$V_{DD}$	—	Power supply	5 V
2	$V_{SS}$	—		GND (0 V)
3	$V_0$	—		For LCD drive
4	RS	H/L	Register select signal H: Data input L: Instruction input	
5	R/W	H/L	H: Data read (module to MPU) L: Data write (MPU to module)	
6	E	H, H to L	Enable	
7~14	DB0~DB7	H/L	Data bus, software selectable 4 or 8 bit mode	

Figure 2-8 shows a functional block diagram of the Lumex LCD display device. The 8-bit data bus is shared with the graphics LCD, but the control signals are all separate.

 The particular model used does not have a backlight and the LCD drive pin is not connected.

**Figure 2-8.** LCD Display Block Diagram

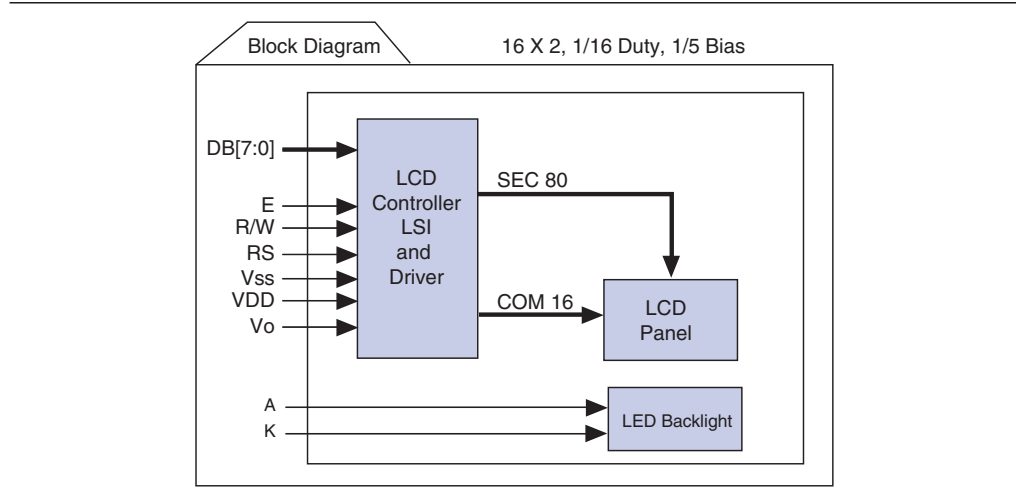



Table 2-38 lists the character LCD display component reference and manufacturing information.

**Table 2-38.** Character LCD Display Component Reference and Manufacturing Information

Board Reference	Description	Manufacturer	Manufacturing Part Number	Manufacturer Website
J4	2 × 7 pin, 100 mil, vertical header	Samtec	TSM-107-01-G-DV	<a href="http://www.samtec.com">www.samtec.com</a>
	2 × 16 character display, 5 × 8 dot matrix	Lumex	LCM-S01602DSR/C	<a href="http://www.lumex.com">www.lumex.com</a>

### Graphics LCD (J13)

The board contains a 30-pin, fine-pitch connector to interface directly to a 128 × 64 dot matrix graphics LCD display via a flex-cable that is soldered to the display itself. The display is an Optrex part number F-51852GNFQJ-LB-AIN (blue pixels) or F-51852GNFQJ-LB-CAN (green pixels). The pin-out of this interface connector is compatible with a variety of displays.

 The data signals are bused with the 14-pin LCD header.

 For the graphics LCD data sheet and related documentation, visit [www.optrex.com](http://www.optrex.com).

Table 2-39 lists the graphics LCD pin name, description, and type. Signal name and direction are relative to the Cyclone III FPGA.

**Table 2-39.** Graphics LCD Interface I/O

Board Reference	Description	I/O Standard	Schematic Signal Name	Cyclone III Device Pin Number
J13 pin 6	LCD data bus bit 0	2.5 V	LCD_DATA0	AA4
J13 pin 7	LCD data bus bit 1	2.5 V	LCD_DATA1	AD1
J13 pin 8	LCD data bus bit 2	2.5 V	LCD_DATA2	V8
J13 pin 9	LCD data bus bit 3	2.5 V	LCD_DATA3	AB5
J13 pin 10	LCD data bus bit 4	2.5 V	LCD_DATA4	AE2
J13 pin 11	LCD data bus bit 5	2.5 V	LCD_DATA5	V5
J13 pin 12	LCD data bus bit 6 _or SCLK	2.5 V	LCD_DATA6	V6
J13 pin 13	LCD data bus bit 7 _or SDATA	2.5 V	LCD_DATA7	AB3
J13 pin 28	Parallel interface selection _high = 68 series, low = 80 series	2.5 V	LCD_BS1	(1)
J13 pin 1	LCD chip select	2.5 V	LCD_CS <sub>n</sub>	AB24
J13 pin 3	LCD data/command select	2.5 V	LCD_D_C <sub>n</sub>	D27
J13 pin 5	LCD read enable	2.5 V	LCD_E_RD <sub>n</sub>	V7
J13 pin 2	LCD reset	2.5 V	LCD_RST <sub>n</sub>	H7
J13 pin 29	LCD parallel/serial data select	2.5 V	LCD_SER <sub>n</sub>	(1)
J13 pin 4	LCD write enable	2.5 V	LCD_WEn	AC4

**Note to Table 2-39:**

(1) For the corresponding Cyclone III device pin number, refer to the MAX II device pin-out information in [Table 2-5 on page 2-7](#).



For more information about the data sheet and related documentation, visit Lumex at [www.lumex.com](http://www.lumex.com).

Table 2-40 is an excerpt from the OPTREX data sheet showing pin definitions for both serial and parallel interfaces. The included display has a parallel interface.

**Table 2-40.** Graphics LCD Pin Definitions

Pin Number	Parallel I/F	
	Name	Description
1	CS1	Chip select signal L: active
2	RES	Reset signal L: reset
3	A0	H: D0 to D7 are display data; L: D0 to D7 are instructions
4	WR	80 family CPU: reset signal L: active
5	RD	80 family CPU: reset signal L: active
6	D0	Display data
7	D1	Display data
8	D2	Display data
9	D3	Display data
10	D4	Display data
11	D5	Display data
12	D6(SCL)	Display data (serial data clock signal input)
13	D7(S1)	Display data (serial data input)
14	V <sub>D0</sub>	Power supply for logic
15	V <sub>SS</sub>	Power supply (0 V.GND)
16	V <sub>OUT</sub>	DC/DC voltage converter output
17	C3-	DC/DC voltage converter negative connection
18	C1+	DC/DC voltage converter positive connection
19	C1-	DC/DC voltage converter negative connection
20	C2-	DC/DC voltage converter negative connection
21	C2+	DC/DC voltage converter positive connection
22	V <sub>1</sub>	Power supply for LCD drive $V_1 = 1/9 \cdot V_S$
23	V <sub>2</sub>	Power supply for LCD drive $V_2 = 2/9 \cdot V_S$
24	V <sub>3</sub>	Power supply for LCD drive $V_3 = 7/9 \cdot V_S$
25	V <sub>4</sub>	Power supply for LCD drive $V_4 = 8/9 \cdot V_S$
26	V <sub>5</sub>	Power supply for LCD drive $V_5, V_{OUT}$
27	V <sub>R</sub>	Voltage adjustment pin. Applies voltage between V <sub>CC</sub> and V <sub>S</sub> using a resistive divider
28	C86	Interface mode select signal H:68 series L: 80 series
29	P/S	Parallel/serial data select signal H: parallel L: serial
30	N/C	Non-connection



Board defaults graphics LCD interface to 80 series CPU mode and parallel interface. These defaults can be modified by writing to the appropriate register in the MAX II CPLD using the FSM bus.

Figure 2-9 is an excerpt from the OPTREX data sheet showing the control chip in the LCD module. The control chip is from New Japan Radio Corporation (part number NJU6676), and Figure 2-9 illustrates the functional block diagram of the display driver.

For more information, contact Optrex American at [www.optrex.com](http://www.optrex.com) or New Japan Radio at [www.njr.co.jp/index\\_e.htm](http://www.njr.co.jp/index_e.htm).

Figure 2-9. Graphics LCD Functional Block Diagram of Display Driver

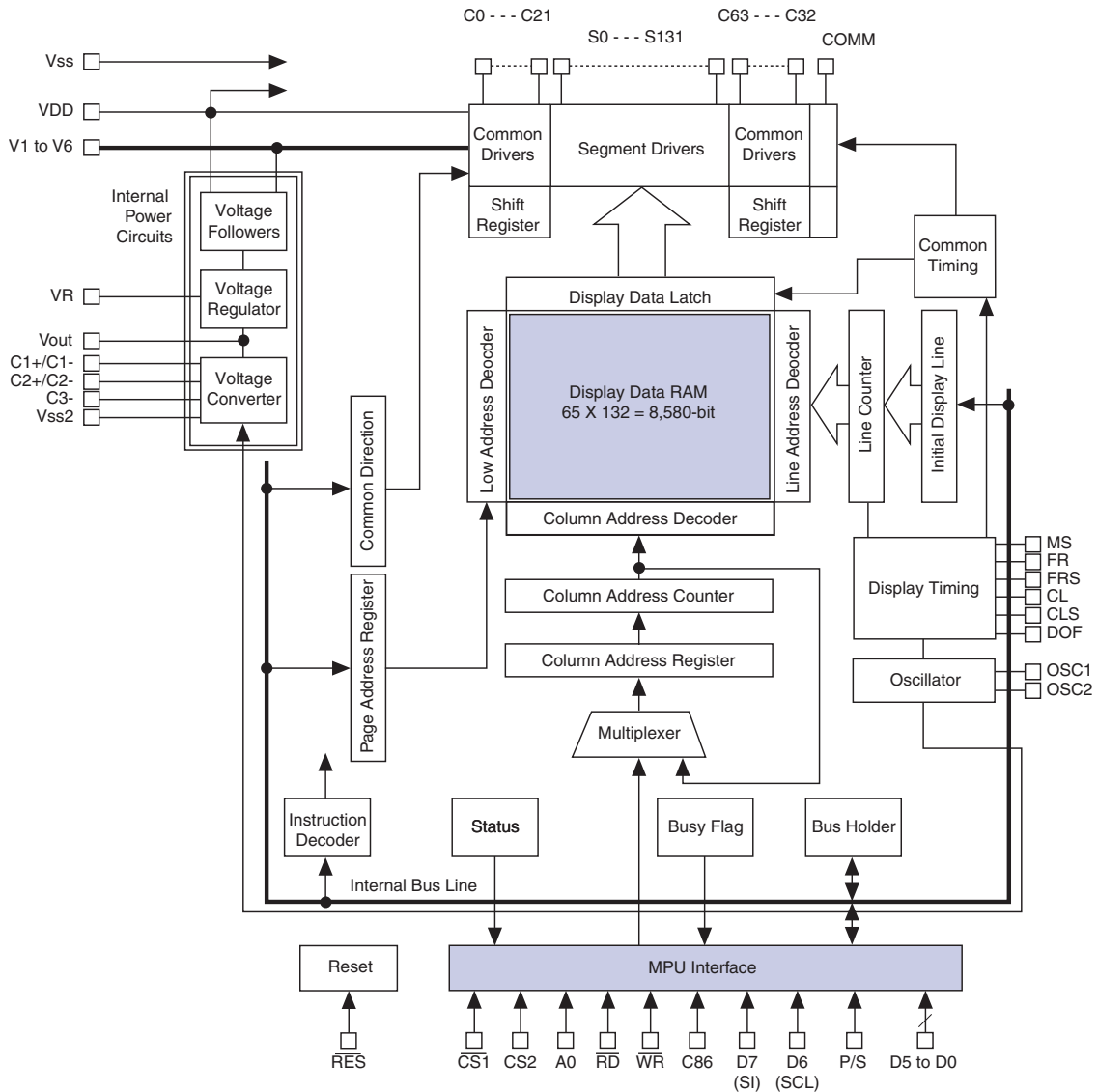
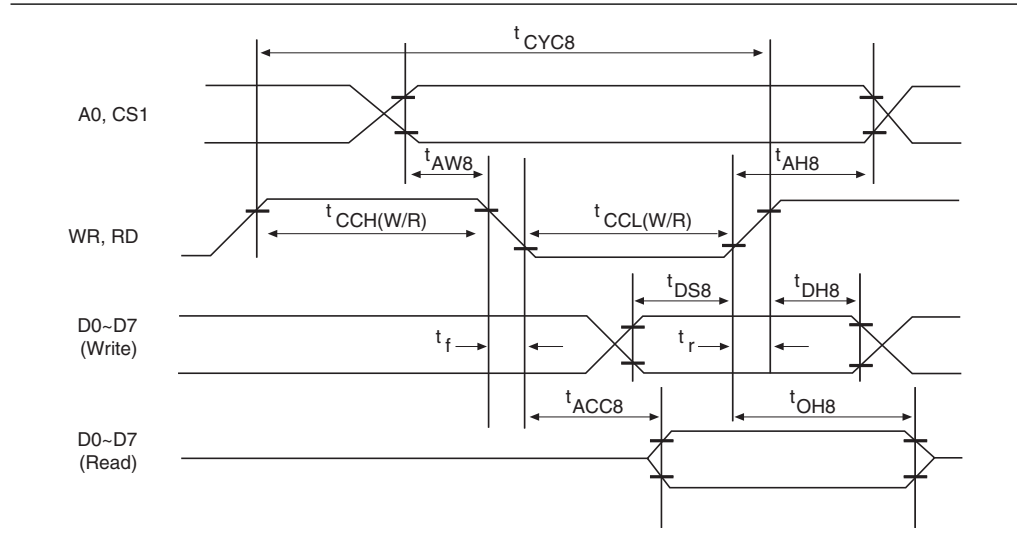

Figure 2-10 is an excerpt from the Optrex data sheet and shows the module interface signals for both read and write transactions.

Figure 2-10. Graphics LCD Timing Diagram



For more information about timing parameters, visit [www.optrex.com](http://www.optrex.com).

Table 2-41 lists the graphics LCD display component reference and manufacturing information.

Table 2-41. Graphics LCD Display Component Reference and Manufacturing Information

Board Reference	Description	Manufacturer	Manufacturing Part Number	Manufacturer Website
J13	FPC/FFC 30-position flick lock connector, bottom contact	Hirose Electronics, Co.	FH12S-30S-0.55H(55)	<a href="http://www.hirose.com">www.hirose.com</a>
	128 × 64 graphics module, blue LCD (1)	Optrex America, Inc.	F-51852GNFQJ-LB-AIN	<a href="http://www.optrex.com">www.optrex.com</a>
	128 × 64 graphics module, green LCD (1)	Optrex America, Inc.	F-51852GNFQJ-LG-ACN	<a href="http://www.optrex.com">www.optrex.com</a>

**Note to Table 2-41:**

(1) The Cyclone III development board is shipped with either a blue or green Optrex LED display.

## Communication Ports and Interfaces

This section describes the board’s communication ports and interfaces relative to the Cyclone III device.

The board supports the following communication ports:

- USB 2.0 MAC /PHY
- 10/100/1000 Ethernet
- HSMC

## USB 2.0 MAC/PHY

The board incorporates the FTDI USB 2.0 PHY chip. The FT245BL (LQFP package) provides an easy cost-effective method of transferring data to/from a peripheral and a host PC at up to 8 million bits (1 Megabyte) per second (Mbps). The simple, FIFO-like design makes interfacing easier.

The device interfaces to J3, a Type B USB connector similar to those used by common peripherals such as digital cameras and printers. The maximum speed of the interface is 12 Mbps. Typical application speeds are around 1.5 Mbps; however, actual system speed may vary.

The primary usage for the USB device is to provide JTAG programming of on-board devices such as the FPGA and flash memory. The interface is also the default means through which the FPGA connects to host PC applications such as SignalTap® II, DSP Builder, and the Nios II JTAG universal asynchronous receiver/transmitter (UART).

Figure 2-11 shows the functional block diagram of the FTDI USB PHY device.

**Figure 2-11.** FTDI USB PHY Block Diagram

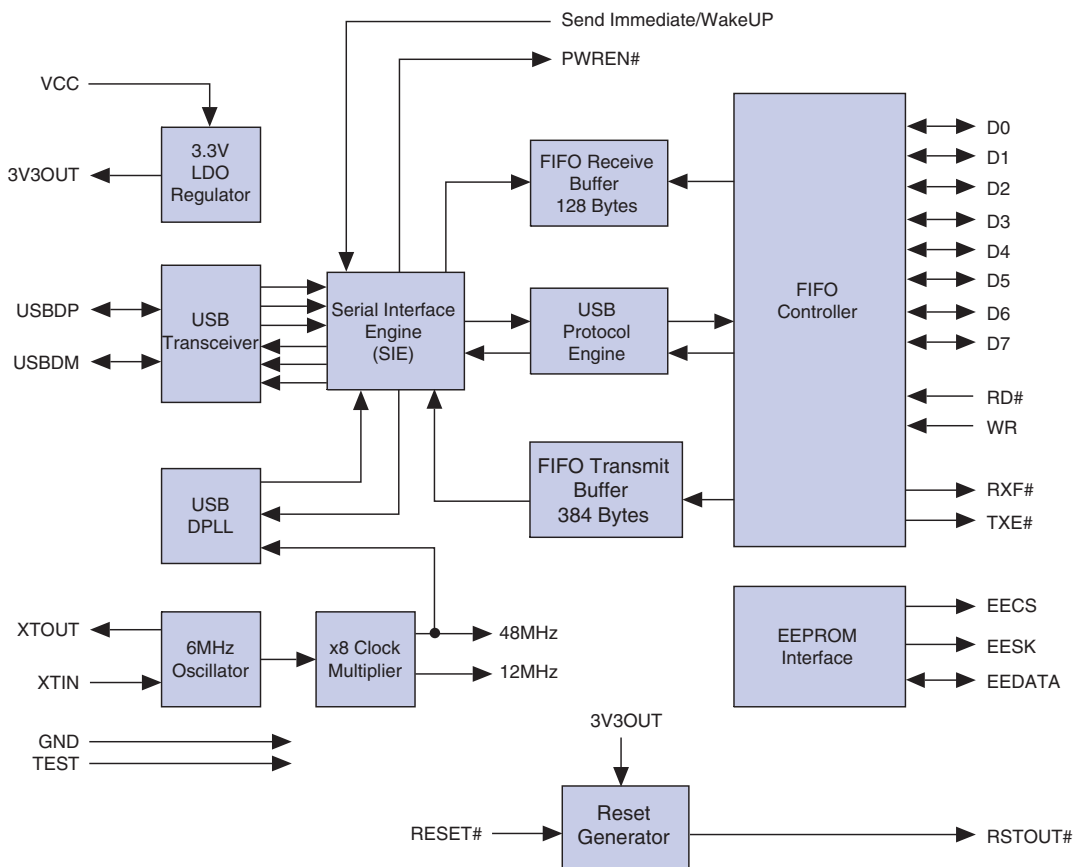

For more information about the data sheet and related documentation, contact FTDI at [www.ftdichip.com](http://www.ftdichip.com).



Table 2-42 lists the FTDI USB interface pins. Signal name and direction are relative to the MAX II CPLD.

**Table 2-42.** FTDI USB PHY Interface I/O

Signal Names	Description	Type
USB_FD (7 : 0)	FIFO data bus	2.5-V CMOS in/out (8 bit) (1)
USB_RDn	FIFO data bus read enable	2.5-V CMOS in (1)
USB_WR	FIFO data bus write enable	2.5-V CMOS in (1)
USB_RXFn	FIFO data bus RX enable	2.5-V CMOS out (1)
USB_TXEn	FIFO data bus TX enable	2.5-V CMOS out (1)
USB_EECS	EEPROM select	N/A
USB_EESK	EEPROM clock	N/A
USB_EEDATA	EEPROM dData	N/A
USB_DP	USB PHY +	N/A
USB_DM	USB PHY -	N/A
USB_RSTn	Reset in	2.5-V CMOS output (1)
USB_RSTOUTn	Reset out	2.5-V CMOS input (1)
USB_XTIN	6-MHz crystal input	N/A
USB_XTOUT	6-MHz crystal output	N/A
USB_PWRENn	Power enable	2.5-V CMOS input (1)
USB_SI_WU	Send immediate / wake up	2.5-V CMOS input (1)
VCC	5-V core power	5.0 V (powered by USB host)
VCCIO	I/O power	3.3 V
AVCC	Analog power	1.2 V
AGND	Analog ground	1.2 V
GND	Ground	Ground

**Note to Table 2-42:**

(1) The FTDI USB 2.0 device uses 3.3-V LVTTTL levels driving into 2.5-V I/O banks on the MAX II CPLD.

Table 2-43 lists the FTDI USB interface component reference and manufacturing information.

**Table 2-43.** FTDI Interface Component Reference and Manufacturing Information

Board Reference	Description	Manufacturer	Manufacturing Part Number	Manufacturer Web Site
U8	FTDI USB device	FTDI Ltd	FT245BL	<a href="http://www.ftdichip.com">www.ftdichip.com</a>

## 10/100/1000 Ethernet

The 10/100/1000 Ethernet PHY port is provided using a dedicated 10/100/1000 base-T, auto-negotiating Ethernet PHY with reduced Gigabit media independent interface (RGMII) to the FPGA. The target device is the Marvell 88E1111, which uses 2.5-V and 1.2-V power rails. The Marvell 88E1111 requires a 25-MHz reference clock driven from a dedicated oscillator.

The Marvell device is provided for copper RS-45 Ethernet connectivity and comes in the BCC96 leadless chip carrier package. The device interfaces to a HALO HFJ11-1G02E model RJ-45.

The PHY device provides 32 internal management registers that can be accessed using the Management Interface (MDIO). The MDIO address of the PHY device is configured to the value 18 (0x12).

Figure 2-12 shows the interface between the FPGA and the PHY device.

**Figure 2-12.** Interface Between the FPGA and the PHY Device

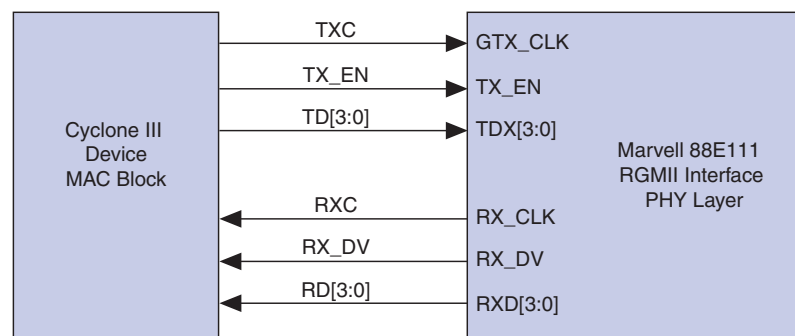

Table 2-44 lists the signal name, description, and I/O standard for the Ethernet PHY interface I/O. The signal name and type are relative to the Cyclone III device, i.e., the I/O setting and direction.

**Table 2-44.** Ethernet PHY Interface I/O (Part 1 of 2)

Board Reference	Description	I/O Standard	Schematic Signal Name	Cyclone III Device Pin Number
U5 pin 8	RGMII interface transmit clock	2.5 V	ENET_GTX_CLK	T8
U5 pin 73	1000 MB link established	2.5 V	ENET_LED_LINK1000	AC25
U5 pin 25	Management bus data clock	2.5 V	ENET_MDC	N8
U5 pin 24	Management bus data	2.5 V	ENET_MDIO	L5
U5 pin 28	Reset	2.5 V	ENET_RESETN	AD2
U5 pin 2	RGMII interface receive clock	1.8 V	ENET_RX_CLK	B14
U5 pin 95	RGMII interface receive data bus bit 0	2.5 V	ENET_RX_D0	W8
U5 pin 92	RGMII interface receive data bus bit 1	2.5 V	ENET_RX_D1	AA6
U5 pin 93	RGMII interface receive data bus bit 2	2.5 V	ENET_RX_D2	W7
U5 pin 91	RGMII interface receive data bus bit 3	2.5 V	ENET_RX_D3	Y6
U5 pin 94	RGMII interface receive control	2.5 V	ENET_RX_DV	AB4
U5 pin 11	RGMII interface transmit data bus bit 0	2.5 V	ENET_TX_D0	W4

**Table 2-44.** Ethernet PHY Interface I/O (Part 2 of 2)

Board Reference	Description	I/O Standard	Schematic Signal Name	Cyclone III Device Pin Number
U5 pin 12	RGMII interface transmit data bus bit 1	2.5 V	ENET_TX_D1	AA5
U5 pin 14	RGMII interface transmit data bus bit 2	2.5 V	ENET_TX_D2	Y5
U5 pin 16	RGMII interface transmit data bus bit 3	2.5 V	ENET_TX_D3	W3
U5 pin 9	RGMII interface transmit control	2.5 V	ENET_TX_EN	AA7

Table 2-45 is an excerpt from the Marvell data sheet with a summary of RGMII interface signals and their functions.

**Table 2-45.** RGMII Signal Definitions

Schematic Signal Name	Marvell Device Pin Name	RGMII Spec Pin Name	Description
ENET_GTX_CLK	GTX_CLK	TXC	125-MHz, 25-MHz, or 2.5-MHz transmit clock with $\pm 50$ ppm tolerance based on the selected speed.
ENET_TX_EN	TX_EN	TX_CTL	Transmit control signals. TX_EN is encoded on the rising edge of GTX_CLK, TX_ER, XORed with TX_EN is encoded on this falling edge of GTX_CLK.
ENET_TXD [3 : 0]	TXD [3 : 0]	TD [3 : 0]	Transmit data. In 1000 base-T and 1000 base-X modes, TXD [3 : 0] are presented on both edges of GTX_CLK. In 100 base-T and 10 base-T modes, TXD [3 : 0] are presented on the rising edge of GTX_CLK.
ENET_RX_CLK	RX_CLK	RXC	125-MHz, 25-MHz, or 2.5-MHz receive clock $\pm 50$ ppm tolerance derived from the received data stream and based on the selected speed.
ENET_RX_DV	RX_DV	RX_CTL	Receive control signals. RX_DV is encoded on the rising edge of RX_CLK, RX_ER XORed with RX_DV is encoded on the falling edge of RX_CLK.
ENET_RXD [3 : 0]	RXD [3 : 0]	RD [3 : 0]	Receive data. In 1000 base-T and 1000 base-X modes, RXD [3 : 0] are presented on both edges of RX_CLK. In 100 base-TX and 10 base-T modes, RXD [3 : 0] are presented on the rising edge of RX_CLK.

Table 2-46 lists the 10/100/1000 Ethernet PHY component reference and manufacturing information.

**Table 2-46.** Ethernet PHY Component Reference and Manufacturing Information

Board Reference	Description	Manufacturer	Manufacturing Part Number	Manufacturer Website
U5	Ethernet PHY Base-T device	Marvell Semiconductor	88E1111-B2-CAA1C000	<a href="http://www.marvell.com">www.marvell.com</a>



For more information about the data sheet and related documentation, contact Marvell at [www.marvell.com](http://www.marvell.com).

## High-Speed Mezzanine Connector

The board contains two HSMC interfaces called Port A and Port B. These HSMC interfaces support both single-ended and differential signaling. The connector part number is Samtec ASP-122953-01. The HSM connector interface also allows for JTAG, SMBus, clock outputs and inputs, as well as power for compatible HSMC daughter cards.

The HSMC is an Altera-developed specification, which allows users to expand the functionality of the development board through the addition of HSMC daughter cards.

 For more information about the HSMC specification such as signaling standards, signal integrity, compatible connectors, and mechanical information, visit [www.altera.com](http://www.altera.com).

The HSM connector has 172 total pins, including 120 signal pins, 39 power pins, and 13 ground pins. The ground pins are located between the two rows of signal and power pins, acting as both a shield and a reference. The HSM connector is based on the 0.5 mm-pitch QSH/QTH family of high-speed, board-to-board connectors from Samtec. There are three banks in this connector. Bank 1 has every third pin removed as is done in the QSH-DP/QTH-DP series. Bank 2 and Bank 3 have all of the pins populated as done in the QSH/QTH series.

The Cyclone III development board does not use Bank 1 transceiver signals intended for clock-data-recover (CDR) applications such as PCI Express and Rapid I/O<sup>®</sup>. These 32 pins are left floating. Banks 2 and 3 are fully supported and can be used in two different configurations. See [Figure 2-13](#).

**Figure 2-13.** HSMC Signal and Bank Diagram

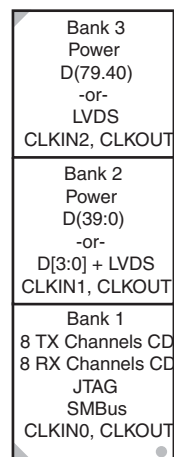

The HSMC interface has programmable bi-directional I/O pins that can be used as 2.5-V LVCMOS, which is 3.3-V LVTTTL-compatible. These pins can also be used as various differential I/O standards including, but not limited to LVDS, mini-LVDS, and RSDS with up to 17-channels full-duplex. Resistor locations are provided for board-level differential termination on designated receiver pairs, but are not installed as CMOS utilization of these pins is the default usage model.

 As noted in the HSMC specification, LVDS and single-ended I/O standards are only guaranteed to function when mixed according to either the generic single-ended pin-out or the generic differential pin-out.

Table 2-47 lists the HSMC Port A interface signal name, description, and I/O standard. Signal name and direction are relative to the Cyclone III FPGA, which is the HSMC host.

**Table 2-47.** HSMC Port A Interface Signal Name, Description, and Type (Part 1 of 3)

Board Reference	Description	I/O Standard	Schematic Signal Name	Cyclone III Device Pin Number
J8 pin 33	Management serial data	2.5 V	HSMA_SDA	AC1
J8 pin 34	Management serial clock	2.5 V	HSMA_SCL	AC3
J8 pin 35	JTAG clock signal	2.5 V	FPGA_JTAG_TCK	P5
J8 pin 36	JTAG mode select signal	2.5 V	FPGA_JTAG_TMS	P8
J8 pin 39	Dedicated CMOS clock out	2.5 V	HSMA_CLK_OUT0	Y7
J8 pin 40	Dedicated CMOS clock in	1.8 V	HSMA_CLK_IN0	AG14
J8 pin 41	Dedicated CMOS I/O bit 0	2.5 V	HSMA_D0	AB6
J8 pin 42	Dedicated CMOS I/O bit 1	2.5 V	HSMA_D1	AF2
J8 pin 43	Dedicated CMOS I/O bit 2	2.5 V	HSMA_D2	AE3
J8 pin 44	Dedicated CMOS I/O bit 3	2.5 V	HSMA_D3	AC5
J8 pin 47	LVDS TX or CMOS I/O bit 0	LVDS or 2.5 V	HSMA_TX_D_P0	R7
J8 pin 48	LVDS RX or CMOS I/O bit 0	LVDS or 2.5 V	HSMA_RX_D_P0	AB2
J8 pin 49	LVDS TX or CMOS I/O bit 0	LVDS or 2.5 V	HSMA_TX_D_N0	R6
J8 pin 50	LVDS RX or CMOS I/O bit 0	LVDS or 2.5 V	HSMA_RX_D_N0	AB1
J8 pin 53	LVDS TX bit 1p or CMOS I/O data 8	LVDS or 2.5 V	HSMA_TX_D_P1	V4
J8 pin 54	LVDS RX bit 1p or CMOS I/O data 9	LVDS or 2.5 V	HSMA_RX_D_P1	Y4
J8 pin 55	LVDS TX bit 1n or CMOS I/O data bit 10	LVDS or 2.5 V	HSMA_TX_D_N1	V3
J8 pin 56	LVDS RX bit 1n or CMOS I/O data bit 11	LVDS or 2.5 V	HSMA_RX_D_N1	Y3
J8 pin 59	LVDS TX bit 2p or CMOS I/O data bit 12	LVDS or 2.5 V	HSMA_TX_D_P2	T4
J8 pin 60	LVDS RX bit 2p or CMOS I/O data bit 13	LVDS or 2.5 V	HSMA_RX_D_P2	U3
J8 pin 61	LVDS TX bit 2n or CMOS I/O data bit 14	LVDS or 2.5 V	HSMA_TX_D_N2	T3
J8 pin 62	LVDS RX bit 2n or CMOS I/O data bit 15	LVDS or 2.5 V	HSMA_RX_D_N2	U4
J8 pin 65	LVDS TX bit 3p or CMOS I/O data bit 16	LVDS or 2.5 V	HSMA_TX_D_P3	R3
J8 pin 66	LVDS RX bit 3p or CMOS I/O data bit 17	LVDS or 2.5 V	HSMA_RX_D_P3	W2
J8 pin 67	LVDS TX bit 3n or CMOS I/O data bit 18	LVDS or 2.5 V	HSMA_TX_D_N3	R4
J8 pin 68	LVDS RX bit 3n or CMOS I/O data bit 19	LVDS or 2.5 V	HSMA_RX_D_N3	W1
J8 pin 71	LVDS TX bit 4p or CMOS I/O data bit 20	LVDS or 2.5 V	HSMA_TX_D_P4	M8
J8 pin 72	LVDS RX bit 4p or CMOS I/O data bit 21	LVDS or 2.5 V	HSMA_RX_D_P4	V2
J8 pin 73	LVDS TX or 4n CMOS I/O data bit 22	LVDS or 2.5 V	HSMA_TX_D_N4	M7
J8 pin 74	LVDS RX 4n or CMOS I/O data bit 23	LVDS or 2.5 V	HSMA_RX_D_N4	V1
J8 pin 77	LVDS TX 5p or CMOS I/O data bit 24	LVDS or 2.5 V	HSMA_TX_D_P5	P2
J8 pin 78	LVDS RX 5p or CMOS I/O data bit 25	LVDS or 2.5 V	HSMA_RX_D_P5	U2

**Table 2-47.** HSMC Port A Interface Signal Name, Description, and Type (Part 2 of 3)

Board Reference	Description	I/O Standard	Schematic Signal Name	Cyclone III Device Pin Number
J8 pin 79	LVDS TX 5n or CMOS I/O data bit 26	LVDS or 2.5 V	HSMA_TX_D_N5	P1
J8 pin 80	LVDS RX 5n or CMOS I/O data bit 27	LVDS or 2.5 V	HSMA_RX_D_N5	U1
J8 pin 83	LVDS TX 6p or CMOS I/O data bit 28	LVDS or 2.5 V	HSMA_TX_D_P6	M4
J8 pin 84	LVDS RX 6p or CMOS I/O data bit 29	LVDS or 2.5 V	HSMA_RX_D_P6	U6
J8 pin 85	LVDS TX 6n or CMOS I/O data bit 30	LVDS or 2.5 V	HSMA_TX_D_N6	M3
J8 pin 86	LVDS RX 6n or CMOS I/O data bit 31	LVDS or 2.5 V	HSMA_RX_D_N6	U5
J8 pin 89	LVDS TX 7p or CMOS I/O data bit 32	LVDS or 2.5 V	HSMA_TX_D_P7	M2
J8 pin 90	LVDS RX 7p or CMOS I/O data bit 33	LVDS or 2.5 V	HSMA_RX_D_P7	R2
J8 pin 91	LVDS TX 7n or CMOS I/O data bit 34	LVDS or 2.5 V	HSMA_TX_D_N7	M1
J8 pin 92	LVDS RX 7n or CMOS I/O data bit 35	LVDS or 2.5 V	HSMA_RX_D_N7	R1
J8 pin 95	LVDS or CMOS clock out	LVDS or 2.5 V	HSMA_CLK_OUT_P1	G6
J8 pin 96	LVDS or CMOS clock in	LVDS or 2.5 V	HSMA_CLK_IN_P1	Y2
J8 pin 97	LVDS or CMOS clock out	LVDS or 2.5 V	HSMA_CLK_OUT_N1	G5
J8 pin 98	LVDS or CMOS clock in	LVDS or 2.5 V	HSMA_CLK_IN_N1	Y1
J8 pin 101	LVDS TX 8p or CMOS I/O data bit 40	LVDS or 2.5 V	HSMA_TX_D_P8	L7
J8 pin 102	LVDS RX 8p or CMOS I/O data bit 41	LVDS or 2.5 V	HSMA_RX_D_P8	N4
J8 pin 103	LVDS TX 8n or CMOS I/O data bit 42	LVDS or 2.5 V	HSMA_TX_D_N8	L6
J8 pin 104	LVDS RX 8n or CMOS I/O data bit 43	LVDS or 2.5 V	HSMA_RX_D_N8	N3
J8 pin 107	LVDS TX 9p or CMOS I/O data bit 44	LVDS or 2.5 V	HSMA_TX_D_P9	K8
J8 pin 108	LVDS RX 9p or CMOS I/O data bit 45	LVDS or 2.5 V	HSMA_RX_D_P9	L4
J8 pin 109	LVDS TX 9n or CMOS I/O data bit 46	LVDS or 2.5 V	HSMA_TX_D_N9	L8
J8 pin 110	LVDS RX 9n or CMOS I/O data bit 47	LVDS or 2.5 V	HSMA_RX_D_N9	L3
J8 pin 113	LVDS TX 10p or CMOS I/O data bit 48	LVDS or 2.5 V	HSMA_TX_D_P10	K4
J8 pin 114	LVDS RX 10p or CMOS I/O data bit 49	LVDS or 2.5 V	HSMA_RX_D_P10	L2
J8 pin 115	LVDS TX 10n or CMOS I/O data bit 50	LVDS or 2.5 V	HSMA_TX_D_N10	K3
J8 pin 116	LVDS RX 10n or CMOS I/O data bit 51	LVDS or 2.5 V	HSMA_RX_D_N10	L1
J8 pin 119	LVDS TX 11p or CMOS I/O data bit 52	LVDS or 2.5 V	HSMA_TX_D_P11	J4
J8 pin 120	LVDS RX 11p or CMOS I/O data bit 53	LVDS or 2.5 V	HSMA_RX_D_P11	K2
J8 pin 121	LVDS TX 11n or CMOS I/O data bit 54	LVDS or 2.5 V	HSMA_TX_D_N11	J3
J8 pin 122	LVDS RX 11n or CMOS I/O data bit 55	LVDS or 2.5 V	HSMA_RX_D_N11	K1
J8 pin 125	LVDS TX 12p or CMOS I/O data bit 56	LVDS or 2.5 V	HSMA_TX_D_P12	J7
J8 pin 126	LVDS RX 12p or CMOS I/O data bit 57	LVDS or 2.5 V	HSMA_RX_D_P12	J6
J8 pin 127	LVDS TX 12n or CMOS I/O data bit 58	LVDS or 2.5 V	HSMA_TX_D_N12	K7
J8 pin 128	LVDS RX 12n or CMOS I/O data bit 59	LVDS or 2.5 V	HSMA_RX_D_N12	J5
J8 pin 131	LVDS TX 13p or CMOS I/O data bit 60	LVDS or 2.5 V	HSMA_TX_D_P13	G2
J8 pin 132	LVDS RX 13p or CMOS I/O data bit 61	LVDS or 2.5 V	HSMA_RX_D_P13	H4
J8 pin 133	LVDS TX 13n or CMOS I/O data bit 62	LVDS or 2.5 V	HSMA_TX_D_N13	G1
J8 pin 134	LVDS RX 13n or CMOS I/O data bit 63	LVDS or 2.5 V	HSMA_RX_D_N13	H3

**Table 2-47.** HSMC Port A Interface Signal Name, Description, and Type (Part 3 of 3)

Board Reference	Description	I/O Standard	Schematic Signal Name	Cyclone III Device Pin Number
J8 pin 137	LVDS TX 14p or CMOS I/O data bit 64	LVDS or 2.5 V	HSMA_TX_D_P14	F5
J8 pin 138	LVDS TX 14p or CMOS I/O data bit 65	LVDS or 2.5 V	HSMA_RX_D_P14	G4
J8 pin 139	LVDS RX 14n or CMOS I/O data bit 66	LVDS or 2.5 V	HSMA_TX_D_N14	F4
J8 pin 140	LVDS RX 14n or CMOS I/O data bit 67	LVDS or 2.5 V	HSMA_RX_D_N14	G3
J8 pin 143	LVDS RX 15p or CMOS I/O data bit 68	LVDS or 2.5 V	HSMA_TX_D_P15	E2
J8 pin 144	LVDS TX 15p or CMOS I/O data bit 69	LVDS or 2.5 V	HSMA_RX_D_P15	F2
J8 pin 145	LVDS RX 15n or CMOS I/O data bit 70	LVDS or 2.5 V	HSMA_TX_D_N15	E1
J8 pin 146	LVDS TX 15n or CMOS I/O data bit 71	LVDS or 2.5 V	HSMA_RX_D_N15	F1
J8 pin 149	LVDS RX 16p or CMOS I/O data bit 72	LVDS or 2.5 V	HSMA_TX_D_P16	D3
J8 pin 150	LVDS TX 16p or CMOS I/O data bit 73	LVDS or 2.5 V	HSMA_RX_D_P16	E3
J8 pin 151	LVDS TX 16n or CMOS I/O data bit 74	LVDS or 2.5 V	HSMA_TX_D_N16	C2
J8 pin 152	LVDS RX 16n or CMOS I/O data bit 75	LVDS or 2.5 V	HSMA_RX_D_N16	F3
J8 pin 155	LVDS or CMOS clock out	LVDS	HSMA_CLK_OUT_P2	D2
J8 pin 156	LVDS or CMOS clock in	LVDS	HSMA_CLK_IN_P2	J2
J8 pin 157	LVDS or CMOS clock out	2.5 V	HSMA_CLK_OUT_N2	D1
J8 pin 158	LVDS or CMOS clock in	2.5 V	HSMA_CLK_IN_N2	J1
N/A	User LED intended to show RX data activity on the HSMC interface	2.5 V	HSMA_RX_LED	AE1
N/A	User LED intended to show TX data activity on the HSMC interface	2.5 V	HSMA_TX_LED	AA3

Table 2-48 lists the HSMC Port B interface signal name, description, and I/O standard. Signal name and direction are relative to the Cyclone III FPGA, which is the HSMC host.

**Table 2-48.** HSMC Port B Interface Signal Name, Description, and Type (Part 1 of 4)

Board Reference	Description	I/O Standard	Schematic Signal Name	Cyclone III Device Pin Number
J9 pin 33	Management serial data	2.5 V	HSMB_SDA	H26
J9 pin 34	Management serial clock	2.5 V	HSMB_SCL	H25
J9 pin 35	JTAG clock signal	2.5 V	FPGA_JTAG_TCK	P5
J9 pin 36	JTAG mode select signal	2.5 V	FPGA_JTAG_TMS	P8
J9 pin 39	Dedicated CMOS clock out	2.5 V	HSMB_CLK_OUT0	J22
J9 pin 40	Dedicated CMOS clock in	2.5 V	HSMB_CLK_IN0	A15
J9 pin 41	Dedicated CMOS I/O bit 0	2.5 V	HSMB_D0	G24
J9 pin 42	Dedicated CMOS I/O bit 1	2.5 V	HSMB_D1	H23
J9 pin 43	Dedicated CMOS I/O bit 2	2.5 V	HSMB_D2	G25
J9 pin 44	Dedicated CMOS I/O bit 3	2.5 V	HSMB_D3	H24
J9 pin 47	LVDS TX 0p or CMOS I/O data bit 4	LVDS or 2.5 V	HSMB_TX_D_P0	J25
J9 pin 48	LVDS RX 0p or CMOS I/O data bit 5	LVDS or 2.5 V	HSMB_RX_D_P0	F27

**Table 2-48.** HSMC Port B Interface Signal Name, Description, and Type (Part 2 of 4)

Board Reference	Description	I/O Standard	Schematic Signal Name	Cyclone III Device Pin Number
J9 pin 49	LVDS TX 0n or CMOS I/O data bit 6	LVDS or 2.5 V	HSMB_TX_D_NO	J26
J9 pin 50	LVDS RX 0n or CMOS I/O data bit 7	LVDS or 2.5 V	HSMB_RX_D_NO	F28
J9 pin 53	LVDS TX 1p or CMOS I/O data bit 8	LVDS or 2.5 V	HSMB_TX_D_P1	L23
J9 pin 54	LVDS RX 1p or CMOS I/O data bit 9	LVDS or 2.5 V	HSMB_RX_D_P1	G27
J9 pin 55	LVDS TX 1n or CMOS I/O data bit 10	LVDS or 2.5 V	HSMB_TX_D_N1	L24
J9 pin 56	LVDS RX 1n or CMOS I/O data bit 11	LVDS or 2.5 V	HSMB_RX_D_N1	G28
J9 pin 59	LVDS TX 2p or CMOS I/O data bit 12	LVDS or 2.5 V	HSMB_TX_D_P2	M25
J9 pin 60	LVDS RX 2p or CMOS I/O data bit 13	LVDS or 2.5 V	HSMB_RX_D_P2	K25
J9 pin 61	LVDS TX 2n or CMOS I/O data bit 14	LVDS or 2.5 V	HSMB_TX_D_N2	M26
J9 pin 62	LVDS RX 2n or CMOS I/O data bit 15	LVDS or 2.5 V	HSMB_RX_D_N2	K26
J9 pin 65	LVDS TX 3p or CMOS I/O data bit 16	LVDS or 2.5 V	HSMB_TX_D_P3	N25
J9 pin 66	LVDS RX 3p or CMOS I/O data bit 17	LVDS or 2.5 V	HSMB_RX_D_P3	K27
J9 pin 67	LVDS TX 3n or CMOS I/O data bit 18	LVDS or 2.5 V	HSMB_TX_D_N3	N26
J9 pin 68	LVDS RX 3n or CMOS I/O data bit 19	LVDS or 2.5 V	HSMB_RX_D_N3	K28
J9 pin 71	LVDS TX 4p or CMOS I/O data bit 20	LVDS or 2.5 V	HSMB_TX_D_P4	R27
J9 pin 72	LVDS RX 4p or CMOS I/O data bit 21	LVDS or 2.5 V	HSMB_RX_D_P4	L27
J9 pin 73	LVDS TX 4n or CMOS I/O data bit 22	LVDS or 2.5 V	HSMB_TX_D_N4	R28
J9 pin 74	LVDS RX 4n or CMOS I/O data bit 23	LVDS or 2.5 V	HSMB_RX_D_N4	L28
J9 pin 77	LVDS TX 5p or CMOS I/O data bit 24	LVDS or 2.5 V	HSMB_TX_D_P5	R25
J9 pin 78	LVDS RX 5p or CMOS I/O data bit 25	LVDS or 2.5 V	HSMB_RX_D_P5	M27
J9 pin 79	LVDS TX 5n or CMOS I/O data bit 26	LVDS or 2.5 V	HSMB_TX_D_N5	R26
J9 pin 80	LVDS RX 5n or CMOS I/O data bit 27	LVDS or 2.5 V	HSMB_RX_D_N5	M28
J9 pin 83	LVDS TX 6p or CMOS I/O data bit 28	LVDS or 2.5 V	HSMB_TX_D_P6	U25
J9 pin 84	LVDS RX 6p or CMOS I/O data bit 29	LVDS or 2.5 V	HSMB_RX_D_P6	P25
J9 pin 85	LVDS TX 6n or CMOS I/O data bit 30	LVDS or 2.5 V	HSMB_TX_D_N6	U26
J9 pin 86	LVDS RX 6n or CMOS I/O data bit 31	LVDS or 2.5 V	HSMB_RX_D_N6	P26
J9 pin 89	LVDS TX 7p or CMOS I/O data bit 32	LVDS or 2.5 V	HSMB_TX_D_P7	V27
J9 pin 90	LVDS RX 7p or CMOS I/O data bit 33	LVDS or 2.5 V	HSMB_RX_D_P7	P27
J9 pin 91	LVDS TX 7n or CMOS I/O data bit 34	LVDS or 2.5 V	HSMB_TX_D_N7	V28
J9 pin 92	LVDS RX 7n or CMOS I/O data bit 35	LVDS or 2.5 V	HSMB_RX_D_N7	P28
J9 pin 95	LVDS or CMOS clock out	LVDS or 2.5 V	HSMB_CLK_OUT_P1	AC26
J9 pin 96	LVDS or CMOS clock in	LVDS or 2.5 V	HSMB_CLK_IN_P1	J27
J9 pin 97	LVDS or CMOS clock out	LVDS or 2.5 V	HSMB_CLK_OUT_N1	AD26
J9 pin 98	LVDS or CMOS clock in	LVDS or 2.5 V	HSMB_CLK_IN_N1	J28
J9 pin 101	LVDS TX 8p or CMOS I/O data bit 40	LVDS or 2.5 V	HSMB_TX_D_P8	V25
J9 pin 102	LVDS RX 8p or CMOS I/O data bit 41	LVDS or 2.5 V	HSMB_RX_D_P8	P21
J9 pin 103	LVDS TX 8n or CMOS I/O data bit 42	LVDS or 2.5 V	HSMB_TX_D_N8	V26
J9 pin 104	LVDS RX 8n or CMOS I/O data bit 43	LVDS or 2.5 V	HSMB_RX_D_N8	R21



**Table 2-48.** HSMC Port B Interface Signal Name, Description, and Type (Part 3 of 4)

Board Reference	Description	I/O Standard	Schematic Signal Name	Cyclone III Device Pin Number
J9 pin 107	LVDS TX 9p or CMOS I/O data bit 44	LVDS or 2.5 V	HSMB_TX_D_P9	W25
J9 pin 108	LVDS RX 9p or CMOS I/O data bit 45	LVDS or 2.5 V	HSMB_RX_D_P9	R22
J9 pin 109	LVDS TX 9n or CMOS I/O data bit 46	LVDS or 2.5 V	HSMB_TX_D_N9	W26
J9 pin 110	LVDS RX 9n or CMOS I/O data bit 47	LVDS or 2.5 V	HSMB_RX_D_N9	R23
J9 pin 113	LVDS TX 10p or CMOS I/O data bit 48	LVDS or 2.5 V	HSMB_TX_D_P10	Y25
J9 pin 114	LVDS RX 10p or CMOS I/O data bit 49	LVDS or 2.5 V	HSMB_RX_D_P10	T25
J9 pin 115	LVDS TX 10n or CMOS I/O data bit 50	LVDS or 2.5 V	HSMB_TX_D_N10	Y26
J9 pin 116	LVDS RX 10n or CMOS I/O data bit 51	LVDS or 2.5 V	HSMB_RX_D_N10	T26
J9 pin 119	LVDS TX 11p or CMOS I/O data bit 52	LVDS or 2.5 V	HSMB_TX_D_P11	AA25
J9 pin 120	LVDS RX 11p or CMOS I/O data bit 53	LVDS or 2.5 V	HSMB_RX_D_P11	U27
J9 pin 121	LVDS TX 11n or CMOS I/O data bit 54	LVDS or 2.5 V	HSMB_TX_D_N11	AA26
J9 pin 122	LVDS RX 11n or CMOS I/O data bit 55	LVDS or 2.5 V	HSMB_RX_D_N11	U28
J9 pin 125	LVDS TX 12p or CMOS I/O data bit 56	LVDS or 2.5 V	HSMB_TX_D_P12	AB25
J9 pin 126	LVDS RX 12p or CMOS I/O data bit 57	LVDS or 2.5 V	HSMB_RX_D_P12	U22
J9 pin 127	LVDS TX 12n or CMOS I/O data bit 58	LVDS or 2.5 V	HSMB_TX_D_N12	AB26
J9 pin 128	LVDS RX 12n or CMOS I/O data bit 59	LVDS or 2.5 V	HSMB_RX_D_N12	V22
J9 pin 131	LVDS TX 13p or CMOS I/O data bit 60	LVDS or 2.5 V	HSMB_TX_D_P13	Y23
J9 pin 132	LVDS RX 13p or CMOS I/O data bit 61	LVDS or 2.5 V	HSMB_RX_D_P13	W28
J9 pin 133	LVDS TX 13n or CMOS I/O data bit 62	LVDS or 2.5 V	HSMB_TX_D_N13	Y24
J9 pin 134	LVDS RX 13n or CMOS I/O data bit 63	LVDS or 2.5 V	HSMB_RX_D_N13	W27
J9 pin 137	LVDS TX 14p or CMOS I/O data bit 64	LVDS or 2.5 V	HSMB_TX_D_P14	AE27
J9 pin 138	LVDS TX 14p or CMOS I/O data bit 65	LVDS or 2.5 V	HSMB_RX_D_P14	V23
J9 pin 139	LVDS RX 14n or CMOS I/O data bit 66	LVDS or 2.5 V	HSMB_TX_D_N14	AE28
J9 pin 140	LVDS RX 14n or CMOS I/O data bit 67	LVDS or 2.5 V	HSMB_RX_D_N14	V24
J9 pin 143	LVDS RX 15p or CMOS I/O data bit 68	LVDS or 2.5 V	HSMB_TX_D_P15	W22
J9 pin 144	LVDS TX 15p or CMOS I/O data bit 69	LVDS or 2.5 V	HSMB_RX_D_P15	AB27
J9 pin 145	LVDS RX 15n or CMOS I/O data bit 70	LVDS or 2.5 V	HSMB_TX_D_N15	Y22
J9 pin 146	LVDS TX 15n or CMOS I/O data bit 71	LVDS or 2.5 V	HSMB_RX_D_N15	AB28
J9 pin 149	LVDS RX 16p or CMOS I/O data bit 72	LVDS or 2.5 V	HSMB_TX_D_P16	V21
J9 pin 150	LVDS TX 16p or CMOS I/O data bit 73	LVDS or 2.5 V	HSMB_RX_D_P16	AC27
J9 pin 151	LVDS TX 16n or CMOS I/O data bit 74	LVDS or 2.5 V	HSMB_TX_D_N16	W21
J9 pin 152	LVDS RX 16n or CMOS I/O data bit 75	LVDS or 2.5 V	HSMB_RX_D_N16	AC28
J9 pin 155	LVDS or CMOS clock out	LVDS	HSMB_CLK_OUT_P2	AD27
J9 pin 156	LVDS or CMOS clock in	LVDS	HSMB_CLK_IN_P2	Y27
J9 pin 157	LVDS or CMOS clock out	2.5 V	HSMB_CLK_OUT_N2	AD28
J9 pin 158	LVDS or CMOS clock in	2.5 V	HSMB_CLK_IN_N2	Y28

**Table 2-48.** HSMC Port B Interface Signal Name, Description, and Type (Part 4 of 4)

Board Reference	Description	I/O Standard	Schematic Signal Name	Cyclone III Device Pin Number
N/A	User LED intended to show RX data activity on the HSMC interface	2.5 V	HSMB_RX_LED	F26
N/A	User LED intended to show TX data activity on the HSMC interface	2.5 V	HSMB_TX_LED	D28

The board provides both 12 V and 3.3 V to installed daughter cards up to 18.6 W each. [Table 2-49](#) shows the maximum current allowed per voltage.

**Table 2-49.** HSMC Power Supply

Voltage	Maximum Current From Host	Maximum Wattage
12 V	1.0 A	12.0 W
3.3 V	2.0 A	6.6 W

[Table 2-50](#) lists HSMC component reference and manufacturing information.

**Table 2-50.** HSMC Component Reference and Manufacturing Information

Board Reference	Description	Manufacturer	Manufacturing Part Number	Manufacturer Website
J8 and J9	High-speed mezzanine card (HSMC), custom version of QSH-DP family high speed socket	Samtec	ASP-122953-01	<a href="http://www.samtec.com">www.samtec.com</a>

## On-Board Memory

This section describes the on-board memory interface support, provides signal name, type, and signal connectivity relative to the Cyclone III device.

The board has the following on-board memory:

- DDR2 SDRAM
- SRAM

### DDR2 SDRAM

The board has 256 MB of dual-channel DDR2 SDRAM memory with a 72-bit data width. These devices use the 1.8-V SSTL signaling standard.

The data bus can be configured as two separate buses of 32 bits each, or a single 32-bit and a single 40-bit bus. One address/control bus is referred to as TOP and the other is referred to as BOT (bottom), as they connect to the respective Cyclone III device edges. The interface comprises four ×16 devices for the 64-bit datapath, and a single ×8 device for the ECC bits for a total of 5 devices (3 to TOP, 2 to BOT). The Micron part numbers are MT47H32M16CC-3 for the ×16 devices and MT47H32M8BP-3 for the ×8 device.

The two address buses are large enough to support any size JEDEC-compliant DDR2 device, as they have all 16 address pins and all three bank pins connected. The Micron components shipped on the board all have 13 row addresses, 2 bank addresses, and 10 column addresses.

 Unused control pins should be left tri-stated to reduce power consumption.

There are three clock pairs driven from the FPGA to the memories. The first two pairs clock two memory devices each. The last clock drives the 5th memory device as well as an additional capacitive load to make all clocks have similar loading.

The maximum frequency is 167 MHz (333 Mbps per pin). The theoretical bandwidth of the entire DDR2 interface is 2667 Mbps plus ECC, or 3,000 Mbps raw throughput.

 For more information, visit Micron at [www.micron.com](http://www.micron.com).

The data interface to the FPGA fabric runs at either one-half or one-quarter the physical layer data rate when using the Altera DDR2 MegaCore function, which equates to a doubling or quadrupling of the physical data bus width (144 bits or 288 bits, respectively). For example, a 72-bit interface with a 200-MHz external clock speed can have a 200 MHz 144-bit internal bus or a 100 MHz 288-bit interface.

To allow for the use of memory device ODT functionality, the ODT signal is connected. Because a board-level Class I termination is also available, use of this feature is optional. Termination resistors are approximately 50Ω to match the trace impedance of the signals on the board. Clocks are terminated using a single 100Ω resistor across each P/N pair. Altera recommends using the 50ΩOCT on the FPGA for data, and the 10 mA setting for the address and control pins. The DDR2 devices should use the reduced drive strength setting available as a register option.

Table 2-51 lists the DDR2 interface signal name, description, and I/O standard. Signal name and direction are relative to the Cyclone III FPGA.

**Table 2-51.** DDR2 Interface I/O (Part 1 of 5)

Board Reference	Description	I/O Standard	Schematic Signal Name	Cyclone III Device Pin Number
U25, U26 pin K8	Differential clock 0n	SSTL18 Class 1	DDR2_CK_N0	AF14
U11, U12 pin K8	Differential clock 1n	SSTL18 Class 1	DDR2_CK_N1	G11
U13 pin F8	Differential clock 2n	SSTL18 Class 1	DDR2_CK_N2	H19
U25, U26 pin J8	Differential clock 0p	SSTL18 Class 1	DDR2_CK_P0	AE14
U11, U12 pin J8	Differential clock 1p	SSTL18 Class 1	DDR2_CK_P1	H12
U13 pin E8	Differential clock 2p	SSTL18 Class 1	DDR2_CK_P2	J19
U26 pin F3	Data mask 0	SSTL18 Class 1	DDR2_DM0	AH19
U26 pin B3	Data mask 1	SSTL18 Class 1	DDR2_DM1	AC15
U25 pin F3	Data mask 2	SSTL18 Class 1	DDR2_DM2	AF8
U25 pin B3	Data mask 3	SSTL18 Class 1	DDR2_DM3	AB9
U11 pin F3	Data mask 4	SSTL18 Class 1	DDR2_DM4	B10
U11 pin B3	Data mask 5	SSTL18 Class 1	DDR2_DM5	A8
U12 pin F3	Data mask 6	SSTL18 Class 1	DDR2_DM6	E15

**Table 2-51.** DDR2 Interface I/O (Part 2 of 5)

Board Reference	Description	I/O Standard	Schematic Signal Name	Cyclone III Device Pin Number
U12 pin B3	Data mask 7	SSTL18 Class 1	DDR2_DM7	C20
U13 pin B3	Data mask 8	SSTL18 Class 1	DDR2_DM8	B23
U26 pin G8	Data 0	SSTL18 Class 1	DDR2_DQ0	AG22
U26 pin G2	Data 1	SSTL18 Class 1	DDR2_DQ1	AH21
U26 pin D7	Data 10	SSTL18 Class 1	DDR2_DQ10	AH18
U26 pin D3	Data 11	SSTL18 Class 1	DDR2_DQ11	AH17
U26 pin D1	Data 12	SSTL18 Class 1	DDR2_DQ12	AF15
U26 pin D9	Data 13	SSTL18 Class 1	DDR2_DQ13	AE17
U26 pin B1	Data 14	SSTL18 Class 1	DDR2_DQ14	AF16
U26 pin B9	Data 15	SSTL18 Class 1	DDR2_DQ15	AB16
U25 pin G8	Data 16	SSTL18 Class 1	DDR2_DQ16	AE11
U25 pin G2	Data 17	SSTL18 Class 1	DDR2_DQ17	AG11
U25 pin H7	Data 18	SSTL18 Class 1	DDR2_DQ18	AG10
U25 pin H3	Data 19	SSTL18 Class 1	DDR2_DQ19	AH11
U26 pin H7	Data 2	SSTL18 Class 1	DDR2_DQ2	AH22
U25 pin H1	Data 20	SSTL18 Class 1	DDR2_DQ20	AE9
U25 pin H9	Data 21	SSTL18 Class 1	DDR2_DQ21	AE12
U25 pin F1	Data 22	SSTL18 Class 1	DDR2_DQ22	AF10
U25 pin F9	Data 23	SSTL18 Class 1	DDR2_DQ23	AE13
U25 pin C8	Data 24	SSTL18 Class 1	DDR2_DQ24	AC8
U25 pin C2	Data 25	SSTL18 Class 1	DDR2_DQ25	AH7
U25 pin D7	Data 26	SSTL18 Class 1	DDR2_DQ26	AG8
U25 pin D3	Data 27	SSTL18 Class 1	DDR2_DQ27	AH8
U25 pin D1	Data 28	SSTL18 Class 1	DDR2_DQ28	AG7
U25 pin D9	Data 29	SSTL18 Class 1	DDR2_DQ29	AA10
U26 pin H3	Data 3	SSTL18 Class 1	DDR2_DQ3	AG21
U25 pin B1	Data 30	SSTL18 Class 1	DDR2_DQ30	AF7
U25 pin B9	Data 31	SSTL18 Class 1	DDR2_DQ31	AD10
U11 pin G8	Data 32	SSTL18 Class 1	DDR2_DQ32	A12
U11 pin G2	Data 33	SSTL18 Class 1	DDR2_DQ33	C14
U11 pin H7	Data 34	SSTL18 Class 1	DDR2_DQ34	A11
U11 pin H3	Data 35	SSTL18 Class 1	DDR2_DQ35	C13
U11 pin H1	Data 36	SSTL18 Class 1	DDR2_DQ36	D15
U11 pin H9	Data 37	SSTL18 Class 1	DDR2_DQ37	C12
U11 pin F1	Data 38	SSTL18 Class 1	DDR2_DQ38	E14
U11 pin F9	Data 39	SSTL18 Class 1	DDR2_DQ39	D13
U26 pin H1	Data 4	SSTL18 Class 1	DDR2_DQ4	AD17
U11 pin C8	Data 40	SSTL18 Class 1	DDR2_DQ40	B7

**Table 2-51.** DDR2 Interface I/O (Part 3 of 5)

Board Reference	Description	I/O Standard	Schematic Signal Name	Cyclone III Device Pin Number
U11 pin C2	Data 41	SSTL18 Class 1	DDR2_DQ4 1	C11
U11 pin D7	Data 42	SSTL18 Class 1	DDR2_DQ4 2	A7
U11 pin D3	Data 43	SSTL18 Class 1	DDR2_DQ4 3	C10
U11 pin D1	Data 44	SSTL18 Class 1	DDR2_DQ4 4	E11
U11 pin D9	Data 45	SSTL18 Class 1	DDR2_DQ4 5	B6
U11 pin B1	Data 46	SSTL18 Class 1	DDR2_DQ4 6	H13
U11 pin B9	Data 47	SSTL18 Class 1	DDR2_DQ4 7	D10
U12 pin G8	Data 48	SSTL18 Class 1	DDR2_DQ4 8	C17
U12 pin G2	Data 49	SSTL18 Class 1	DDR2_DQ4 9	B19
U26 pin H9	Data 5	SSTL18 Class 1	DDR2_DQ5	AH23
U12 pin H7	Data 50	SSTL18 Class 1	DDR2_DQ5 0	B18
U12 pin H3	Data 51	SSTL18 Class 1	DDR2_DQ5 1	C19
U12 pin H1	Data 52	SSTL18 Class 1	DDR2_DQ5 2	D20
U12 pin H9	Data 53	SSTL18 Class 1	DDR2_DQ5 3	C16
U12 pin F1	Data 54	SSTL18 Class 1	DDR2_DQ5 4	A19
U12 pin F9	Data 55	SSTL18 Class 1	DDR2_DQ5 5	E17
U12 pin C8	Data 56	SSTL18 Class 1	DDR2_DQ5 6	C21
U12 pin C2	Data 57	SSTL18 Class 1	DDR2_DQ5 7	C22
U12 pin D7	Data 58	SSTL18 Class 1	DDR2_DQ5 8	A21
U12 pin D3	Data 59	SSTL18 Class 1	DDR2_DQ5 9	A22
U26 pin F1	Data 6	SSTL18 Class 1	DDR2_DQ6	AE19
U12 pin D1	Data 60	SSTL18 Class 1	DDR2_DQ6 0	C24
U12 pin D9	Data 61	SSTL18 Class 1	DDR2_DQ6 1	B21
U12 pin B1	Data 62	SSTL18 Class 1	DDR2_DQ6 2	D21
U12 pin B9	Data 63	SSTL18 Class 1	DDR2_DQ6 3	E18
U13 pin C8	Data 64	SSTL18 Class 1	DDR2_DQ6 4	E22
U13 pin C2	Data 65	SSTL18 Class 1	DDR2_DQ6 5	C25
U13 pin D7	Data 66	SSTL18 Class 1	DDR2_DQ6 6	A23
U13 pin D3	Data 67	SSTL18 Class 1	DDR2_DQ6 7	B25
U13 pin D1	Data 68	SSTL18 Class 1	DDR2_DQ6 8	A26
U13 pin D9	Data 69	SSTL18 Class 1	DDR2_DQ6 9	F21
U26 pin F9	Data 7	SSTL18 Class 1	DDR2_DQ7	AF24
U13 pin B1	Data 70	SSTL18 Class 1	DDR2_DQ7 0	B26
U13 pin B9	Data 71	SSTL18 Class 1	DDR2_DQ7 1	D22
U26 pin C8	Data 8	SSTL18 Class 1	DDR2_DQ8	AG18
U26 pin C2	Data 9	SSTL18 Class 1	DDR2_DQ9	AG17
U26 pin F7	Data strobe 0	SSTL18 Class 1	DDR2_DQS 0	AE18
U26 pin B7	Data strobe 1	SSTL18 Class 1	DDR2_DQS 1	AF17

Table 2-51. DDR2 Interface I/O (Part 4 of 5)

Board Reference	Description	I/O Standard	Schematic Signal Name	Cyclone III Device Pin Number
U25 pin F7	Data strobe 2	SSTL18 Class 1	DDR2_DQS2	AF11
U25 pin B7	Data strobe 3	SSTL18 Class 1	DDR2_DQS3	AE10
U11 pin F7	Data strobe 4	SSTL18 Class 1	DDR2_DQS4	D12
U11 pin B7	Data strobe 5	SSTL18 Class 1	DDR2_DQS5	E12
U12 pin F7	Data strobe 6	SSTL18 Class 1	DDR2_DQS6	B17
U12 pin B7	Data strobe 7	SSTL18 Class 1	DDR2_DQS7	D17
U13 pin B7	Data strobe 8	SSTL18 Class 1	DDR2_DQS8	A25
U25, U26 pin M8	Bottom address 0	SSTL18 Class 1	DDR2BOT_A0	AB22
U25, U26 pin M3	Bottom address 1	SSTL18 Class 1	DDR2BOT_A1	AG6
U25, U26 pin M2	Bottom address 10	SSTL18 Class 1	DDR2BOT_A10	AE4
U25, U26 pin P7	Bottom address 11	SSTL18 Class 1	DDR2BOT_A11	AF21
U25, U26 pin R2	Bottom address 12	SSTL18 Class 1	DDR2BOT_A12	Y12
U25, U26 pin R8	Bottom address 13	SSTL18 Class 1	DDR2BOT_A13	Y14
U25, U26 pin R3	Bottom address 14	SSTL18 Class 1	DDR2BOT_A14	AF12
U25, U26 pin R7	Bottom address 15	SSTL18 Class 1	DDR2BOT_A15	AA16
U25, U26 pin M7	Bottom address 2	SSTL18 Class 1	DDR2BOT_A2	Y13
U25, U26 pin N2	Bottom address 3	SSTL18 Class 1	DDR2BOT_A3	AE7
U25, U26 pin N8	Bottom address 4	SSTL18 Class 1	DDR2BOT_A4	AB12
U25, U26 pin N3	Bottom address 5	SSTL18 Class 1	DDR2BOT_A5	AC7
U25, U26 pin N7	Bottom address 6	SSTL18 Class 1	DDR2BOT_A6	AD12
U25, U26 pin P2	Bottom address 7	SSTL18 Class 1	DDR2BOT_A7	AB8
U25, U26 pin P8	Bottom address 8	SSTL18 Class 1	DDR2BOT_A8	AH12
U25, U26 pin P3	Bottom address 9	SSTL18 Class 1	DDR2BOT_A9	AB10
LED D16 pin 2	Bottom bus activity LED	1.8 V	DDR2BOT_ACTIVE	AA14
U25, U26 pin L2	Bottom bank address 0	SSTL18 Class 1	DDR2BOT_BA0	AF3
U25, U26 pin L3	Bottom bank address 1	SSTL18 Class 1	DDR2BOT_BA1	AF5
U25, U26 pin L1	Bottom bank address 2	SSTL18 Class 1	DDR2BOT_BA2	AH4
U25, U26 pin L7	Bottom column address strobe	SSTL-18 Class I	DDR2BOT_CASn	AD21
U25, U26 pin K2	Bottom clock enable	SSTL-18 Class I	DDR2BOT_CKE	AG4
U25, U26 pin L8	Bottom chip select	SSTL-18 Class I	DDR2BOT_CSn	AC21
U25, U26 pin K9	Bottom on-die termination enable	SSTL-18 Class I	DDR2BOT_ODT	AE24
U25, U26 pin K7	Bottom row address strobe	SSTL-18 Class I	DDR2BOT_RASn	AE21
U25, U26 pin K3	Bottom write enable	SSTL-18 Class I	DDR2BOT_WEn	AE5
U11, U12 pin M8, U13 pin H8	Top address 0	SSTL18 Class 1	DDR2TOP_A0	J13
U11, U12 pin M3, U13 pin H3	Top address 1	SSTL18 Class 1	DDR2TOP_A1	G18
U11, U12 pin M2, U13 pin H2	Top address 10	SSTL18 Class 1	DDR2TOP_A10	A17

**Table 2-51.** DDR2 Interface I/O (Part 5 of 5)

Board Reference	Description	I/O Standard	Schematic Signal Name	Cyclone III Device Pin Number
U11, U12 pin P7, U13 pin K7	Top address 11	SSTL18 Class 1	DDR2TOP_A11	D8
U11, U12 pin R2, U13 pin L2	Top address 12	SSTL18 Class 1	DDR2TOP_A12	D25
U11, U12 pin R8, U13 pin L8	Top address 13	SSTL18 Class 1	DDR2TOP_A13	F15
U11, U12 pin R3, U13 pin L3	Top address 14	SSTL18 Class 1	DDR2TOP_A14	B12
U11, U12 pin R7	Top address 15	SSTL18 Class 1	DDR2TOP_A15	H16
U11, U12 pin M7, U13 pin H7	Top address 2	SSTL18 Class 1	DDR2TOP_A2	E8
U11, U12 pin N2, U13 pin J2	Top address 3	SSTL18 Class 1	DDR2TOP_A3	D24
U11, U12 pin N8, U13 pin J8	Top address 4	SSTL18 Class 1	DDR2TOP_A4	D7
U11, U12 pin N3, U13 pin J3	Top address 5	SSTL18 Class 1	DDR2TOP_A5	J15
U11, U12 pin N7, U13 pin J7	Top address 6	SSTL18 Class 1	DDR2TOP_A6	H15
U11, U12 pin P2, U13 pin K2	Top address 7	SSTL18 Class 1	DDR2TOP_A7	J16
U11, U12 pin P8, U13 pin K8	Top address 8	SSTL18 Class 1	DDR2TOP_A8	H8
U11, U12 pin P3, U13 pin K3	Top address 9	SSTL18 Class 1	DDR2TOP_A9	D16
LED D11 pin 2	Top bus activity LED	1.8 V	DDR2TOP_ACTIVE	E10
U11, U12 pin L2, U13 pin G2	Top bank address 0	SSTL18 Class 1	DDR2TOP_BA0	C23
U11, U12 pin L3, U13 pin G3	Top bank address 1	SSTL18 Class 1	DDR2TOP_BA1	D19
U11, U12 pin L1, U13 pin G1	Top bank address 2	SSTL18 Class 1	DDR2TOP_BA2	C26
U11, U12 pin L7, U13 pin G7	Top column address strobe	SSTL-18 Class I	DDR2TOP_CASn	F14
U11, U12 pin K2, U13 pin F2	Top clock enable	SSTL-18 Class I	DDR2TOP_CKE	E21
U11, U12 pin L8, U13 pin G8	Top chip select	SSTL-18 Class I	DDR2TOP_CSn	C7
U11, U12 pin K9, U13 pin F9	Top on-die termination enable	SSTL-18 Class I	DDR2TOP_ODT	A6
U11, U12 pin K7, U13 pin F7	Top row address strobe	SSTL-18 Class I	DDR2TOP_RASn	F8
U11, U12 pin K3, U13 pin F3	Top write enable	SSTL-18 Class I	DDR2TOP_WEn	A10

Table 2-52 lists the DDR2 interface component reference and manufacturing information.

**Table 2-52.** DDR2 Interface Component Reference and Manufacturing Information

Board Reference	Description	Manufacturer	Manufacturing Part Number	Manufacturer Website
U11, U12, U25, U26	DDR2 SDRAM 34 M × 16	Micron Technology, Inc.	MT47H32M16CC-3:B	<a href="http://www.micron.com">www.micron.com</a>
U13	DDR2 SDRAM 32 M × 8	Micron Technology, Inc.	MT47H32M8BP-3:B	<a href="http://www.micron.com">www.micron.com</a>

## SRAM

The board features 8 MB of SRAM memory with a 32-bit data bus. The devices use 1.8-V CMOS signaling and are optimized for low cost and power.

The 32-bit interface comprises two  $\times 16$  devices. The Samsung part features a maximum frequency of 104 MHz (104 Mbps). The theoretical bandwidth of the entire interface is 416 Mbps.

The SRAM devices are part of a shared bus with connectivity to the MAX II CPLD as well as the flash memory, which is called the FSM bus. All three devices use 1.8-V CMOS signaling. Altera recommends using the 50- $\Omega$ OCT setting on the FPGA and the one-half drive setting on the SRAM.

Table 2-53 lists the SRAM interface signal name, description, and I/O standard. Signal name and type are relative to the Cyclone III device, i.e., I/O setting and direction.

**Table 2-53.** SRAM Interface I/O (Part 1 of 3)

Board Reference	Description	I/O Standard	Schematic Signal Name	Cyclone III Device Pin Number
U23 pin A1	Byte enables bit 0	1.8 V	SRAM_BEn0	AF20
U23 pin B2	Byte enables bit 1	1.8 V	SRAM_BEn1	AH26
U24 pin A1	Byte enables bit 2	1.8 V	SRAM_BEn2	AE22
U24 pin B2	Byte enables bit 3	1.8 V	SRAM_BEn3	AB21
U23, U24 pin J2	Clock (drives two memories)	1.8 V	SRAM_CLK	AD22
U23, U24 pin B5	Chip select	1.8 V	SRAM_CS <sub>n</sub>	AB19
U23, U24 pin A2	Output enable	1.8 V	SRAM_OEn	AD25
U23, U24 pin A6	Power save /MRS set pin	1.8 V	SRAM_PSn	B4
U23 pin J1	Data wait bit 0	1.8 V	SRAM_WAIT0	AG15
U24 pin J1	Data wait bit 1	1.8 V	SRAM_WAIT1	AH25
U23, U24 pin G5	Write enable	1.8 V	SRAM_WEn	AE25
U23, U24 pin J3	Address valid	1.8 V	SRAM_ADV <sub>n</sub>	AA19
U23, U24 pin A3	Address bit 1 (DWORD aligned)	1.8 V	FSA1	AH10
U23, U24 pin A4	Address bit 2 (DWORD aligned)	1.8 V	FSA2	AA13
U23, U24 pin A5	Address bit 3 (DWORD aligned)	1.8 V	FSA3	AC10
U23, U24 pin B3	Address bit 4 (DWORD aligned)	1.8 V	FSA4	Y15
U23, U24 pin B4	Address bit 5 (DWORD aligned)	1.8 V	FSA5	AF22
U23, U24 pin C3	Address bit 6 (DWORD aligned)	1.8 V	FSA6	AF26
U23, U24 pin C4	Address bit 7 (DWORD aligned)	1.8 V	FSA7	AF4
U23, U24 pin D4	Address bit 8 (DWORD aligned)	1.8 V	FSA8	AD8
U23, U24 pin H2	Address bit 9 (DWORD aligned)	1.8 V	FSA9	AG26
U23, U24 pin H3	Address bit 10 (DWORD aligned)	1.8 V	FSA10	AH6
U23, U24 pin H4	Address bit 11 (DWORD aligned)	1.8 V	FSA11	AD24
U23, U24 pin H5	Address bit 12 (DWORD aligned)	1.8 V	FSA12	AF9
U23, U24 pin G3	Address bit 13 (DWORD aligned)	1.8 V	FSA13	AA8



**Table 2-53.** SRAM Interface I/O (Part 2 of 3)

Board Reference	Description	I/O Standard	Schematic Signal Name	Cyclone III Device Pin Number
U23, U24 pin G4	Address bit 14 (DWORD aligned)	1.8 V	FSA14	AC22
U23, U24 pin F3	Address bit 15 (DWORD aligned)	1.8 V	FSA15	AE8
U23, U24 pin F4	Address bit 16 (DWORD aligned)	1.8 V	FSA16	AF13
U23, U24 pin E4	Address bit 17 (DWORD aligned)	1.8 V	FSA17	AB14
U23, U24 pin D3	Address bit 18 (DWORD aligned)	1.8 V	FSA18	AF23
U23, U24 pin H1	Address bit 19 (DWORD aligned)	1.8 V	FSA19	AG12
U23, U24 pin G2	Address bit 20 (DWORD aligned)	1.8 V	FSA20	AB18
U23, U24 pin H6	Address bit 21 (DWORD aligned)	1.8 V	FSA21	Y19
U23 pin B6	Data bit 0	1.8 V	FSD0	J14
U23 pin C5	Data bit 1	1.8 V	FSD1	D6
U23 pin C6	Data bit 2	1.8 V	FSD2	J17
U23 pin D5	Data bit 3	1.8 V	FSD3	G7
U23 pin E5	Data bit 4	1.8 V	FSD4	F18
U23 pin F5	Data bit 5	1.8 V	FSD5	C6
U23 pin F6	Data bit 6	1.8 V	FSD6	H17
U23 pin G6	Data bit 7	1.8 V	FSD7	C18
U23 pin B1	Data bit 8	1.8 V	FSD8	D18
U23 pin C1	Data bit 9	1.8 V	FSD9	G16
U23 pin C2	Data bit 10	1.8 V	FSD10	G22
U23 pin D2	Data bit 11	1.8 V	FSD11	F12
U23 pin E2	Data bit 12	1.8 V	FSD12	D11
U23 pin F2	Data bit 13	1.8 V	FSD13	E24
U23 pin F1	Data bit 14	1.8 V	FSD14	H21
U23 pin G1	Data bit 15	1.8 V	FSD15	G9
U24 pin B6	Data bit 16	1.8 V	FSD16	A4
U24 pin C5	Data bit 17	1.8 V	FSD17	G13
U24 pin C6	Data bit 18	1.8 V	FSD18	H14
U24 pin D5	Data bit 19	1.8 V	FSD19	B8
U24 pin E5	Data bit 20	1.8 V	FSD20	C8
U24 pin F5	Data bit 21	1.8 V	FSD21	F7
U24 pin F6	Data bit 22	1.8 V	FSD22	B11
U24 pin G6	Data bit 23	1.8 V	FSD23	B22
U24 pin B1	Data bit 24	1.8 V	FSD24	A18
U24 pin C1	Data bit 25	1.8 V	FSD25	G8
U24 pin C2	Data bit 26	1.8 V	FSD26	J12
U24 pin D2	Data bit 27	1.8 V	FSD27	D9
U24 pin E2	Data bit 28	1.8 V	FSD28	C9
U24 pin F2	Data bit 29	1.8 V	FSD29	E7

**Table 2-53.** SRAM Interface I/O (Part 3 of 3)

Board Reference	Description	I/O Standard	Schematic Signal Name	Cyclone III Device Pin Number
U24 pin F1	Data bit 30	1.8 V	FSD30	H10
U24 pin G1	Data bit 31	1.8 V	FSD31	J10

Figure 2-14 illustrates the latency for both fixed and variable modes of operation. For asynchronous accesses, each of the two devices has its own WAIT pin wired to the Cyclone III device.

 For Samsung SRAM pin definitions, data sheet, and other related documentation, refer to the Samsung website at [www.samsung.com](http://www.samsung.com).

**Figure 2-14.** SRAM Latency Timing Illustration

Table 2-54 lists the Samsung device latency values based on operation frequency.

**Table 2-54.** SRAM Latency Vs. Frequency

Item	Up to 66 MHz		Up to 80 MHz		Up to 104 MHz	
	Fixed	Variable	Fixed	Variable	Fixed	Variable
Latency set (A11:A10:A9)	4(0:0:1)	2(1:0:0)	5(0:1:0)	3(0:0:0)	7(1:0:1)	4(0:0:1)
Read latency (min)	4	2/4	5	3/5th	7	4/7
First read data fetch clock	5th	3rd/5th	6th	4th/6th	8th	5th/8th
Write latency (min)	2	2	3	3	4	4
First write data loading clock	3rd	3rd	3rd	4th	5th	5th

Figure 2-15 and Figure 2-16 show the Samsung device read and write access waveforms, respectively.

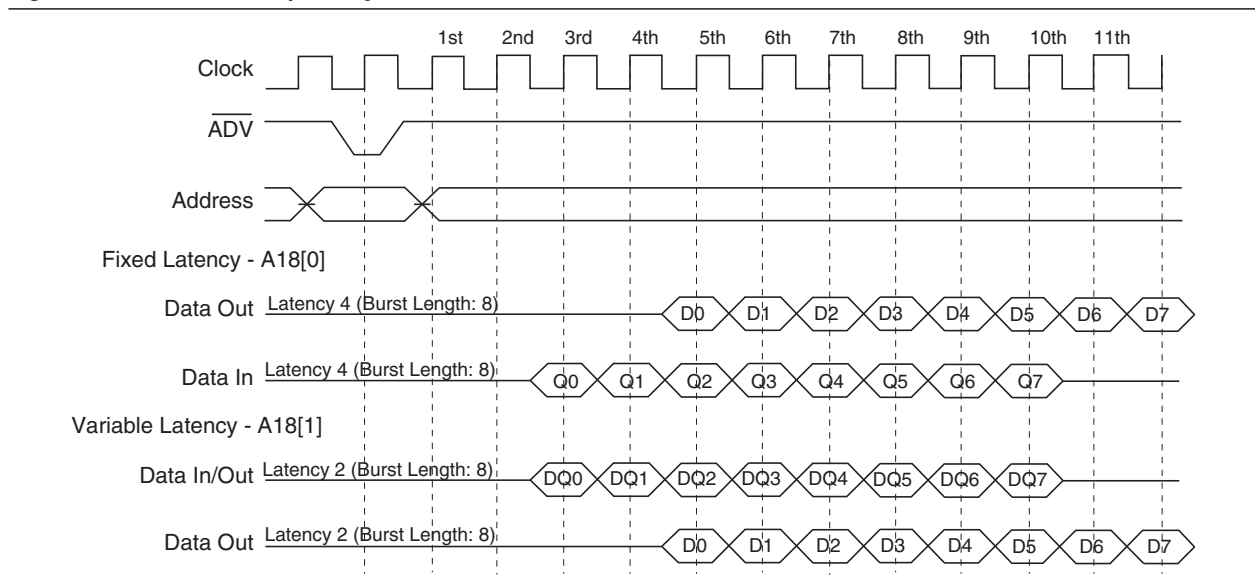
Figure 2-15. SRAM Read Timing Waveforms

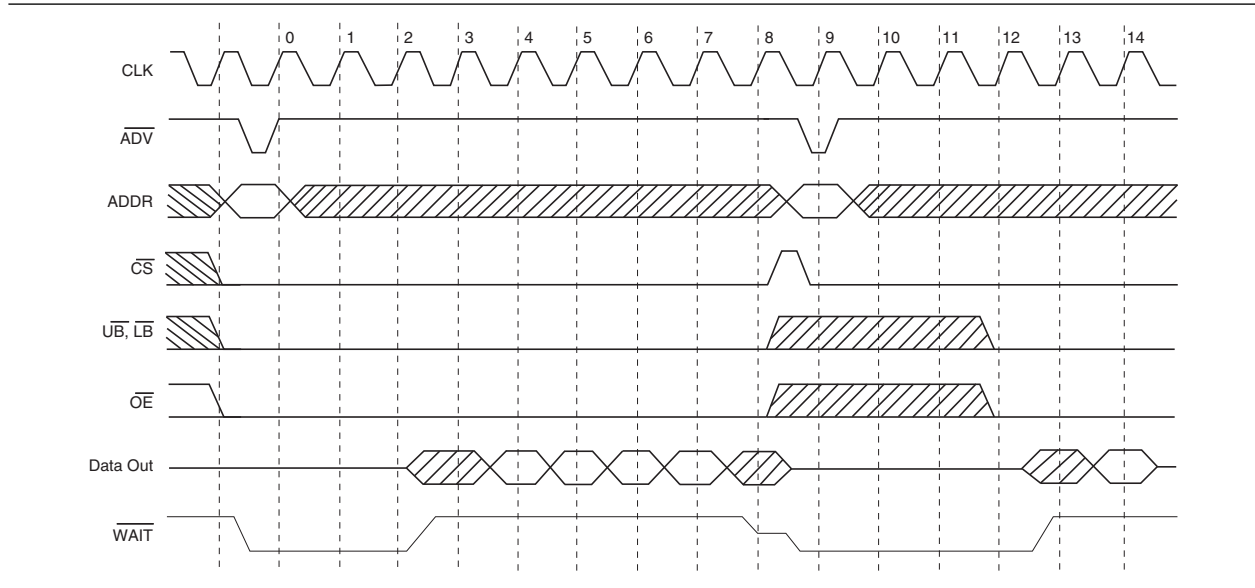

Figure 2-16. SRAM Write Timing Waveforms

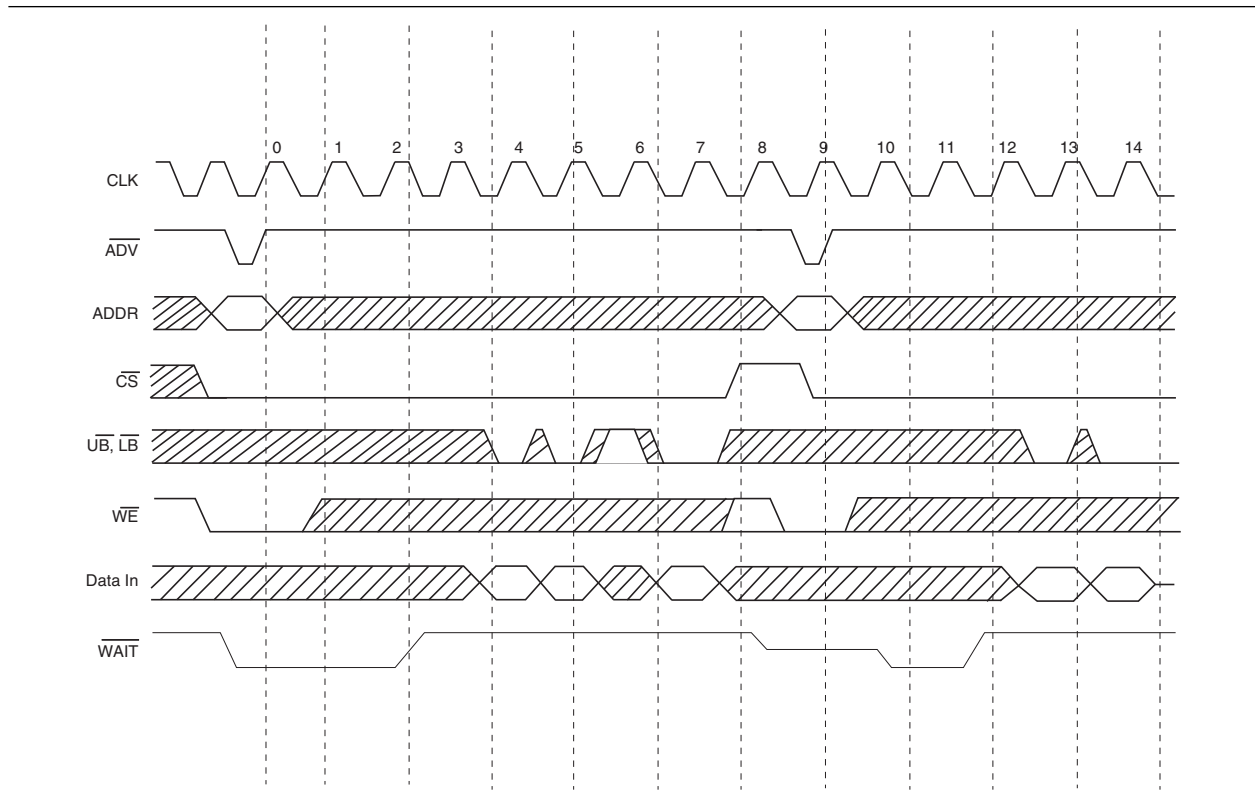

Table 2-55 lists the SRAM board reference and manufacturing information.

**Table 2-55.** SRAM Manufacturing Information

Board Reference	Description	Manufacturer	Manufacturer Part Number	Manufacturer Website
U23, U24	32 MB (2 M × 16) of SRAM	Samsung Semiconductor	K1B3216B2E-BI70	<a href="http://www.samsung.com">www.samsung.com</a>



For more information about timing parameter values, mode register settings (MRS), or any other data regarding the Samsung device, visit [www.samsung.com](http://www.samsung.com).

## Flash Memory

The board features 64 MB of flash memory with a 16-bit data bus. The device uses 1.8-V CMOS signaling and is used for storing configuration files for the FPGA as well as any other files such as Nios software binaries, libraries, images, and sounds.

The interface uses a single Spansion device. The part number is S29GL512N11FFIV1. The device features CFI flash command support, byte- and word-mode operation, and 110 ns access times for a theoretical read bandwidth of 145 Mbps.

The flash device is part of a shared bus with connectivity to the MAX II CPLD as well as the SRAM memory, which is called the FSM bus. All three devices use 1.8-V CMOS signaling. Altera recommends using the 50-ΩOCT setting on the FPGA. The flash does not have a drive strength setting.

Table 2-56 shows the required signals for flash memory. Signal direction is relative to the FPGA.

**Table 2-56.** Flash Interface I/O (Part 1 of 2)

Board Reference	Description	I/O Standard	Schematic Signal Name	Cyclone III Device Pin Number
U31 pin F2	Chip enable	1.8 V	FLASH_CEn	Y16
U31 pin G2	Output enable	1.8 V	FLASH_OEn	Y17
U31 pin A4	Ready/busy	1.8 V	FLASH_RDYBSYn	AG25
U31 pin B5	Reset	1.8 V	FLASH_RESETrn	AB20
U31 pin A5	Write enable	1.8 V	FLASH_WEn	AA21
U31 pin F7	Word/byte	1.8 V	FLASH_BYTEEn	(1)
U31 pin E2	Address bus bit 0 (word aligned)	1.8 V	FSA0	AC11
U31 pin D2	Address bus bit 1 (word aligned)	1.8 V	FSA1	AH10
U31 pin C2	Address bus bit 2 (word aligned)	1.8 V	FSA2	AA13
U31 pin A2	Address bus bit 3 (word aligned)	1.8 V	FSA3	AC10
U31 pin B2	Address bus bit 4 (word aligned)	1.8 V	FSA4	Y15
U31 pin D3	Address bus bit 5 (word aligned)	1.8 V	FSA5	AF22
U31 pin C3	Address bus bit 6 (word aligned)	1.8 V	FSA6	AF26
U31 pin A3	Address bus bit 7 (word aligned)	1.8 V	FSA7	AF4
U31 pin B6	Address bus bit 8 (word aligned)	1.8 V	FSA8	AD8
U31 pin A6	Address bus bit 9 (word aligned)	1.8 V	FSA9	AG26

**Table 2-56.** Flash Interface I/O (Part 2 of 2)

Board Reference	Description	I/O Standard	Schematic Signal Name	Cyclone III Device Pin Number
U31 pin C6	Address bus bit 10 (word aligned)	1.8 V	FSA10	AH6
U31 pin D6	Address bus bit 11 (word aligned)	1.8 V	FSA11	AD24
U31 pin B7	Address bus bit 12 (word aligned)	1.8 V	FSA12	AF9
U31 pin A7	Address bus bit 13 (word aligned)	1.8 V	FSA13	AA8
U31 pin C7	Address bus bit 14 (word aligned)	1.8 V	FSA14	AC22
U31 pin D7	Address bus bit 15 (word aligned)	1.8 V	FSA15	AE8
U31 pin E7	Address bus bit 16 (word aligned)	1.8 V	FSA16	AF13
U31 pin B3	Address bus bit 17 (word aligned)	1.8 V	FSA17	AB14
U31 pin C4	Address bus bit 18 (word aligned)	1.8 V	FSA18	AF23
U31 pin D5	Address bus bit 19 (word aligned)	1.8 V	FSA19	AG12
U31 pin D4	Address bus bit 20 (word aligned)	1.8 V	FSA20	AB18
U31 pin C5	Address bus bit 21 (word aligned)	1.8 V	FSA21	Y19
U31 pin B8	Address bus bit 22 (word aligned)	1.8 V	FSA22	AG3
U31 pin C8	Address bus bit 23 (word aligned)	1.8 V	FSA23	AE16
U31 pin F8	Address bus bit 24 (word aligned)	1.8 V	FSA24	AB7
U31 pin E3	Data bit 0	1.8 V	FSD0	J14
U31 pin H3	Data bit 1	1.8 V	FSD1	D6
U31 pin E4	Data bit 2	1.8 V	FSD2	J17
U31 pin H4	Data bit 3	1.8 V	FSD3	G7
U31 pin H5	Data bit 4	1.8 V	FSD4	F18
U31 pin E5	Data bit 5	1.8 V	FSD5	C6
U31 pin H6	Data bit 6	1.8 V	FSD6	H17
U31 pin E6	Data bit 7	1.8 V	FSD7	C18
U31 pin F3	Data bit 8	1.8 V	FSD8	D18
U31 pin G3	Data bit 9	1.8 V	FSD9	G16
U31 pin F4	Data bit 10	1.8 V	FSD10	G22
U31 pin G4	Data bit 11	1.8 V	FSD11	F12
U31 pin F5	Data bit 12	1.8 V	FSD12	D11
U31 pin G6	Data bit 13	1.8 V	FSD13	E24
U31 pin F6	Data bit 14	1.8 V	FSD14	H21
U31 pin G7	Data bit 15	1.8 V	FSD15	G9

**Note to Table 2-56:**

(1) For the corresponding Cyclone III device pin number, refer to the MAX II device pin-out information in [Table 2-5 on page 2-7](#).

Table 2-57 defines the flash memory map and lists the signals required for flash memory. Signal directions are relative to the Cyclone FPGA.

**Table 2-57.** Flash Memory Map Defined

Signal Name	Description	I/O Standard
FSM_A (24 : 0)	Address bus (word aligned)	1.8-V LVCMOS out (25 bits)
FSM_D (15 : 0)	Data bus	N/A (Accounted for in SRAM section)
FLASH_CS <sub>n</sub>	Chip select	1.8-V LVCMOS out
FLASH_OE <sub>n</sub>	Output enable	1.8-V LVCMOS out
FLASH_WE <sub>n</sub>	Write enable	1.8-V LVCMOS out
FLASH_RST <sub>n</sub>	Reset	1.8-V LVCMOS out
FLASH_WP <sub>n</sub>	Write protect	N/A (Tie to VCC)
FLASH_RDYBSY <sub>n</sub>	Ready/not busy	N/A (Tie to CPLD)
FLASH_BYTE <sub>n</sub>	Byte/word select	N/A (Tie to CPLD)
VIO	I/O power	1.8 V
VCC	Core power	3.3 V
VSS	Ground	Ground
Cyclone III device I/O totals: 29 1.8 V CMOS I/O pins		

Table 2-58 shows the flash device memory map on the Cyclone III development board. The memory provides non-volatile storage for a minimum of eight FPGA bit streams, as well as various settings data used for on-board devices such as Ethernet TCP/IP defaults, PFL configuration bits, and data on the board itself. The remaining area is designated as user flash area for storage of software binaries and other data relevant to a user FPGA design.

**Table 2-58.** Flash Memory Map (Part 1 of 2)

Name	Address
PFL option bits	0x03FE.0080 0x03FE.0000
Ethernet option bits	0x03FD.FFEF 0x03FC.0000
User space (32 MB)	0x03F9.FFFF 0x0200.0000
Reserved	0x01FF.FFFF 0x01C0.0000
FPGA design 7	0x01BE.EBE1 0x0188.0000
FPGA design 6	0x0186.EBE1 0x0150.0000
FPGA design 5	0x014E.EBE1 0x0118.0000
FPGA design 4	0x0116.EBE1 0x00E0.0000

**Table 2-58.** Flash Memory Map (Part 2 of 2)

Name	Address
FPGA Design 3	0x00DE.EBE1 0x00A8.0000
FPGA Design 2	0x00A6.EBE1 0x0070.0000
FPGA Design 1	0x006E.EBE1 0x0038.0000
FPGA Design 0 (factory design)	0x0036.EBE1 0x0000.0000

 For information about the flash array command set and sequencing for register access, or any other data regarding the Spansion device, visit [www.spansion.com](http://www.spansion.com).

Table 2-59 and Table 2-60 are from the Spansion flash device data sheet. The tables show the top and bottom sections of the flash sector map, along with the manufacturer's sector address map.

**Table 2-59.** Flash Sector Map – Bottom

Sector	A24-A16									Sector Size (KBytes) Kwords	8-Bit Address Range (In hexadecimal)	16-bit Address Range (In hexadecimal)
SA0	0	0	0	0	0	0	0	0	0	128/64	0000000-001FFFFF	0000000-000FFFFF
SA1	0	0	0	0	0	0	0	0	1	128/64	0020000-003FFFFF	0010000-001FFFFF
SA2	0	0	0	0	0	0	0	1	0	128/64	0040000-005FFFFF	0020000-002FFFFF
SA3	0	0	0	0	0	0	0	1	1	128/64	0060000-007FFFFF	0030000-003FFFFF
SA4	0	0	0	0	0	0	1	0	0	128/64	0080000-009FFFFF	0040000-004FFFFF
SA5	0	0	0	0	0	0	1	0	1	128/64	00A0000-00BFFFFF	0050000-005FFFFF

**Table 2-60.** Flash Sector Map – Top

Sector	A24-A16									Sector Size (Kbytes) Kwords	8-Bit Address Range (In hexadecimal)	16-bit Address Range (In hexadecimal)
SA508	1	1	1	1	1	1	1	0	0	128/64	3F80000-3F9FFFFF	1FC0000-1FCFFFFF
SA509	1	1	1	1	1	1	1	0	1	128/64	3FA0000-3FBFFFFF	1FD0000-1FDFFFFF
SA510	1	1	1	1	1	1	1	1	0	128/64	3FC0000-3FDFFFFF	1FE0000-1FEFFFFF
SA511	1	1	1	1	1	1	1	1	1	128/64	3FE0000-3FFFFFFF	1FF0000-1FFFFFFF

Table 2-61 lists Spansion flash board reference and manufacturing information.

**Table 2-61.** Spansion Flash Manufacturing Information

Board Reference	Description	Manufacturer	Manufacturer Part Number	Manufacturer Website
U31	64 MB of flash memory	Spansion LLC	S29GL512N11FFIV1	<a href="http://www.spansion.com">www.spansion.com</a>

## Power Supply

The board's power is provided through an IBM laptop style DC power input. The input voltage must be in the range of 14 V to 20 V. The DC voltage is then stepped down to the various power rails used by the components on the board and installed into the HSM connectors.

Figure 2-17 shows the power distribution system, which uses current power rails as described in "POWER SELECT Rotary Switch" on page 2-21. Regulator inefficiencies and sharing are reflected in the currents shown.



Figure 2-17. Power Distribution System

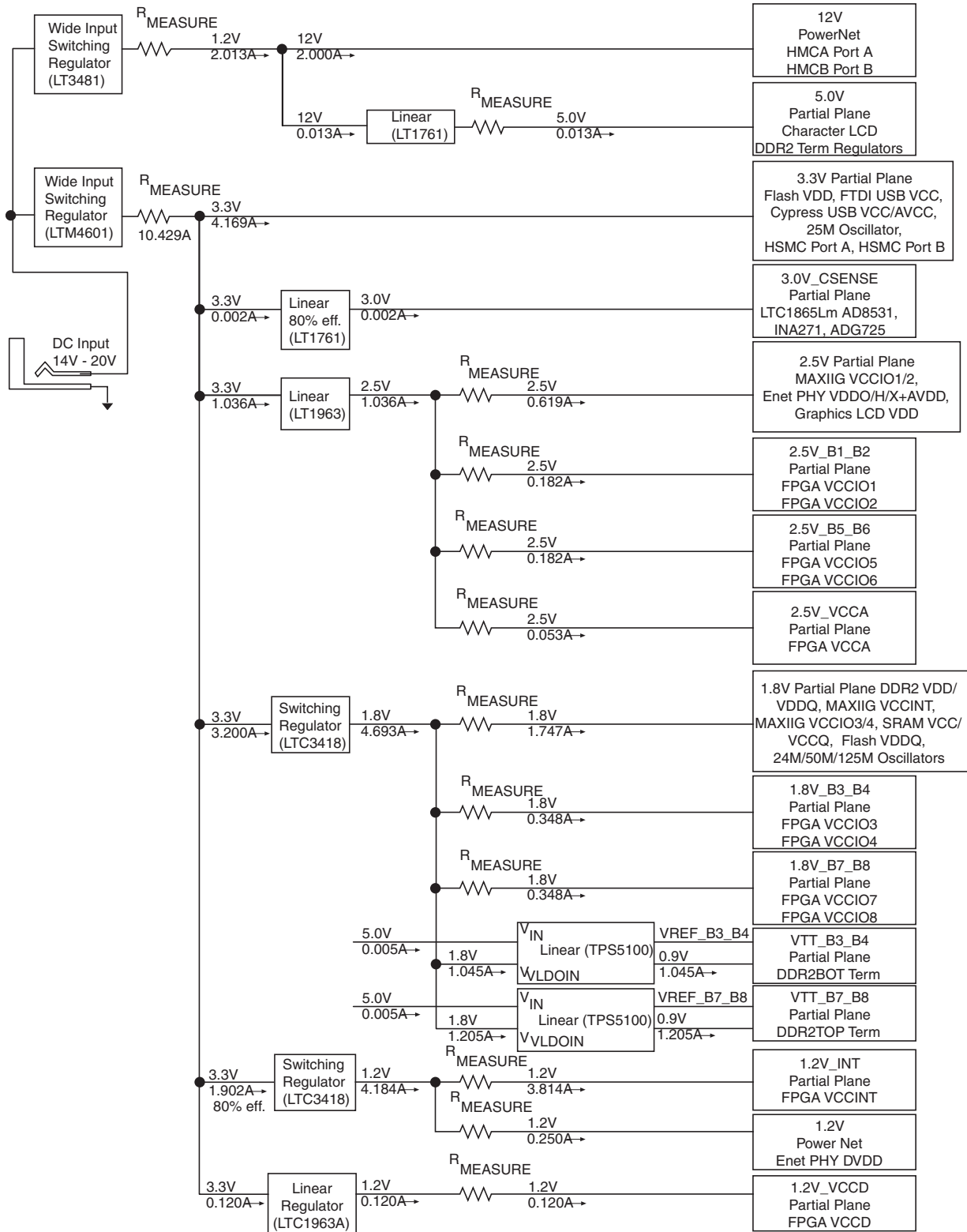

## Power Measurement

Eight power supply rails have on-board voltage and current sense capabilities. These measurements are made using an 8-channel differential A/D converter from Linear Technology, with a serial data bus connected to the MAX II CPLD.

The MAX II CPLD contains a logic design that continually monitors the power rails and displays the current in mW on the dedicated four-digit 7-segment display. Rotary switch SW4 is used to select the power rail being displayed. The sense resistor is large enough that it can be easily probed by a user to confirm the display results. The results are also accessible from the FPGA through register access across the FSM bus.

Figure 2-18 illustrates the circuit.

Figure 2-18. Power Measurement Circuit

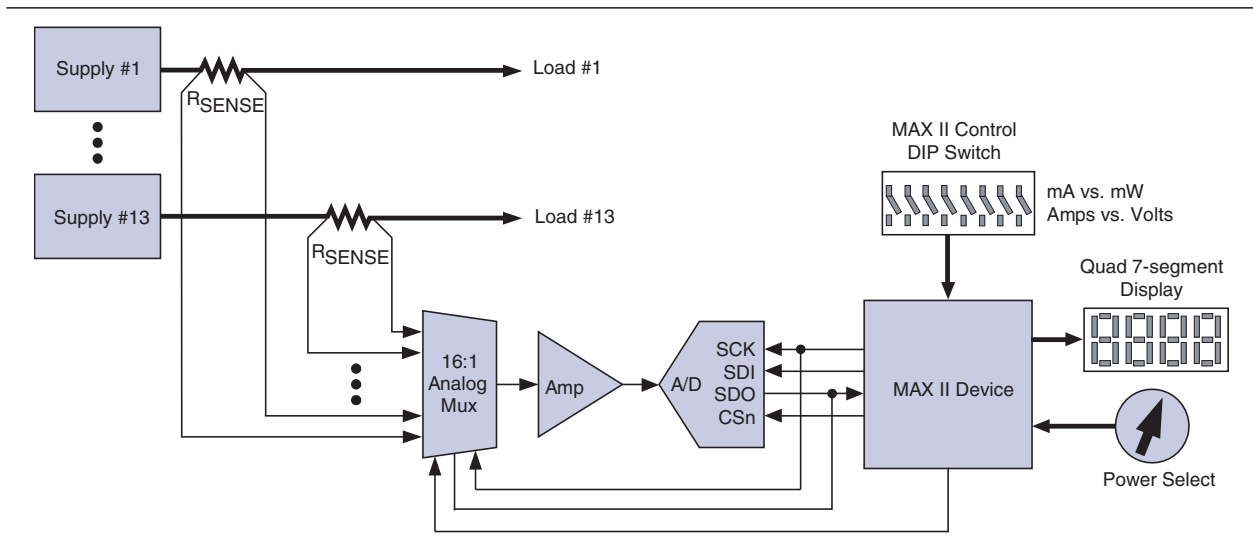

Table 2-16 on page 2-21 lists the power measurement rails. The *Schematic Signal Name* column lists the power rail being measured, and the power pins/devices attached to the power rail are listed in the *Power Pin Name* and *Description* columns.



## Statement of China-RoHS Compliance

Table 2-62 lists hazardous substances included with the kit.

Table 2-62. Table of Hazardous Substances' Name and Concentration Notes (1), (2) (Part 1 of 2)

Part Name	Lead (Pb)	Cadmium (Cd)	Hexavalent Chromium (Cr6+)	Mercury (Hg)	Polybrominated biphenyls (PBB)	Polybrominated diphenyl Ethers (PBDE)
Cyclone III development board	X*	0	0	0	0	0
12-V power supply	0	0	0	0	0	0
Type A-B USB cable	0	0	0	0	0	0

**Table 2-62.** Table of Hazardous Substances' Name and Concentration *Notes (1), (2)* (Part 2 of 2)

<b>Part Name</b>	<b>Lead (Pb)</b>	<b>Cadmium (Cd)</b>	<b>Hexavalent Chromium (Cr6+)</b>	<b>Mercury (Hg)</b>	<b>Polybrominated biphenyls (PBB)</b>	<b>Polybrominated diphenyl Ethers (PBDE)</b>
User guide	0	0	0	0	0	0

**Notes to Table 2-62:**

- (1) 0 indicates that the concentration of the hazardous substance in all homogeneous materials in the parts is below the relevant threshold of the SJ/T11363-2006 standard.
- (2) X\* indicates that the concentration of the hazardous substance of at least one of all homogeneous materials in the parts is above the relevant threshold of the SJ/T11363-2006 standard, but it is exempted by EU RoHS.



## Revision History

The following table displays the revision history for this reference manual.

Date	Version	Changes Made
March 2009	1.4	Updated <a href="#">Table 2–10</a> and <a href="#">Table 2–12</a> .
December 2008	1.3	Corrected “Schematic Signal Names” in <a href="#">Table 2–47</a> and <a href="#">Table 2–48</a> .
August 2008	1.2	<ul style="list-style-type: none"> <li>■ Corrected “Schematic Signal Names” in <a href="#">Table 2–5</a> and added <a href="#">(Note 1)</a>.</li> <li>■ Updated JTAG settings in <a href="#">Table 2–7</a>.</li> <li>■ Updated <a href="#">Table 2–16</a>.</li> <li>■ Updated the power supply information of banks 1, 2, 5, and 6 in <a href="#">Figure 2–6</a>.</li> <li>■ Updated <a href="#">(Note 1)</a> in <a href="#">Table 2–39</a> and <a href="#">(Note 1)</a> in <a href="#">Table 2–39</a> to point to MAX II pin-out information.</li> <li>■ Updated “<a href="#">10/100/1000 Ethernet</a>” section.</li> <li>■ Corrected unit in “<a href="#">Power Measurement</a>” section.</li> <li>■ Converted document to new frame template and made textual and style changes.</li> </ul>
March 2008	1.1	<ul style="list-style-type: none"> <li>■ Added schematic information to, revised I/O standard terminology, and added data bit information to the HSMC Port A and Port B tables.</li> <li>■ Added schematic information to and revised I/O standard terminology to the DDR 2 interface I/O table.</li> <li>■ Added schematic information to and revised I/O standard terminology to the Ethernet PHY I/O table.</li> <li>■ Added schematic information to and revised I/O standard terminology to the flash memory I/O table.</li> <li>■ Added schematic information to and revised I/O standard terminology to the graphics LCD table.</li> <li>■ Added schematic information to and revised I/O standard terminology to the SRAM table.</li> <li>■ Updated power measurement table.</li> <li>■ Updated flash memory map table.</li> <li>■ Added flash memory map definition table.</li> </ul>
October 2007	1.0	First publication

## How to Contact Altera

For the most up-to-date information about Altera products, refer to the following table.

Contact <i>(Note 1)</i>	Contact Method	Address
Technical support	Website	<a href="http://www.altera.com/support">www.altera.com/support</a>
Technical training	Website	<a href="http://www.altera.com/training">www.altera.com/training</a>
	Email	<a href="mailto:custrain@altera.com">custrain@altera.com</a>
Product literature	Website	<a href="http://www.altera.com/literature">www.altera.com/literature</a>
Non-technical support (General) (Software Licensing)	Email	<a href="mailto:nacomp@altera.com">nacomp@altera.com</a>
	Email	<a href="mailto:authorization@altera.com">authorization@altera.com</a>





**Note to Table:**

(1) You can also contact your local Altera sales office or sales representative.

## Typographic Conventions

This document uses the typographic conventions shown in the following table.

Visual Cue	Meaning
<b>Bold Type with Initial Capital Letters</b>	Indicates command names, dialog box titles, dialog box options, and other GUI labels. For example, <b>Save As</b> dialog box.
<b>bold type</b>	Indicates directory names, project names, disk drive names, file names, file name extensions, and software utility names. For example, <b>qdesigns</b> directory, <b>d:</b> drive, and <b>chiptrip.gdf</b> file.
<i>Italic Type with Initial Capital Letters</i>	Indicates document titles. For example, <i>AN 519: Stratix IV Design Guidelines</i> .
<i>Italic type</i>	Indicates variables. For example, $n + 1$ . Variable names are enclosed in angle brackets (<>). For example, <file name> and <project name>.pof file.
Initial Capital Letters	Indicates keyboard keys and menu names. For example, Delete key and the Options menu.
“Subheading Title”	Quotation marks indicate references to sections within a document and titles of Quartus II Help topics. For example, “Typographic Conventions.”
Courier type	Indicates signal, port, register, bit, block, and primitive names. For example, data1, tdi, and input. Active-low signals are denoted by suffix n. For example, resetn. Indicates command line commands and anything that must be typed exactly as it appears. For example, c:\qdesigns\tutorial\chiptrip.gdf. Also indicates sections of an actual file, such as a Report File, references to parts of files (for example, the AHDL keyword SUBDESIGN), and logic function names (for example, TRI).
1., 2., 3., and a., b., c., and so on.	Numbered steps indicate a list of items when the sequence of the items is important, such as the steps listed in a procedure.
■ ■	Bullets indicate a list of items when the sequence of the items is not important.
	The hand points to information that requires special attention.

<b>Visual Cue</b>	<b>Meaning</b>
	A caution calls attention to a condition or possible situation that can damage or destroy the product or your work.
	A warning calls attention to a condition or possible situation that can cause you injury.
	The angled arrow instructs you to press Enter.
	The feet direct you to more information about a particular topic.





## X-ON Electronics

Largest Supplier of Electrical and Electronic Components

*Click to view similar products for [Programmable Logic IC Development Tools](#) category:*

*Click to view products by [Intel](#) manufacturer:*

Other Similar products are found below :

[DK-DEV-5SGXEA7N](#) [SLG4DVKADV](#) [88980182](#) [DEV-17526](#) [DEV-17514](#) [LCMXO3L-SMA-EVN](#) [471-014](#) [80-001005](#) [iCE40UP5K-MDP-EVN](#) [ALTHYDRAC5GX](#) [ALTNITROC5GX](#) [471-015](#) [Hinj](#) [SnoMakrR10](#) [DK-DEV-1SDX-P-A](#) [DK-DEV-1SDX-P-0ES](#) [DK-DEV-1SGX-L-A](#) [DK-DEV-1SMC-H-A](#) [DK-DEV-1SMX-H-0ES](#) [DK-DEV-1SMX-H-A](#) [DK-DEV-4CGX150N](#) [DK-DEV-5CGTD9N](#) [DK-DEV-5CSXC6N](#) [DK-DEV-5M570ZN](#) [DK-MAXII-1270N](#) [DK-SI-1SGX-H-A](#) [DK-SI-1STX-E-0ES](#) [DK-SI-1STX-E-A](#) [DK-SI-5SGXEA7N](#) [ATF15XX-DK3-U](#) [SLG46824V-DIP](#) [SLG46826V-DIP](#) [240-114-1](#) [6003-410-017](#) [ICE40UP5K-B-EVN](#) [DK-SOC-1SSX-L-D](#) [ICE5LP4K-WDEV-EVN](#) [L-ASC-BRIDGE-EVN](#) [LC4256ZE-B-EVN](#) [LCMXO2-7000HE-B-EVN](#) [LCMXO3D-9400HC-B-EVN](#) [LCMXO3L-6900C-S-EVN](#) [LF-81AGG-EVN](#) [LFE3-MEZZ-EVN](#) [LIF-MD6000-ML-EVN](#) [LPTM-ASC-B-EVN](#) [M2S-HELLO-FPGA-KIT](#) [VIDEO-DC-USXGMII](#) [12GSDIFMCCD](#) [SFP+X4FMCCD](#)