

# Qualified Functional Safety Data Package

## Reduce Development Time, System Complexity, and Certification Risk

### Safety Data Package Contents:

- Silicon Integration – How to qualify devices using the reliability report
- Tools and Tool Flow – How to use Intel® Quartus® Prime software and develop FPGAs according to IEC 61508
- Suggested RTL coding guidelines for FPGA development
- Diagnostic IP with IEC 61508 documentation and source code: single event upset (SEU) test, clock check, and cyclic redundancy check (CRC) test modules
- Intel Quartus Prime Standard software version 17.0.2
- Intel-qualified devices up to Cyclone® V, Cyclone IV, Arria® V, and Stratix® V FPGAs and MAX® 10, MAX V, MAX II and MAX II Z CPLDs
- Intel IP including Nios® II embedded processor
- The latest FPGA device reliability report

### Summary

Industrial automation, transportation, the smart grid, automotive, military, aerospace, and medical require machinery and products are highly reliable, and certified for functional safety. Safety is a central requirement when you develop machinery that must comply with worldwide established safety standards such as IEC 61508 and ISO 26262.

When you develop a safe product, you need to consider safety as a core system functionality. Design challenges include:

- Adopting quality management standards, a “safe” design methodology, and safety concepts
- Accounting for additional project effort (time and technology), resulting in longer time to market and higher cost of ownership

### Impact of Functional Safety

Typical design steps to develop an application, before safety:



If you add some of the required steps to design a safe application and achieve functional safety certification (in yellow), you can see the significant project complexity:



Having immediate access to qualified semiconductor data, intellectual property (IP), development flows, and design tools from Intel can significantly shorten overall project time by one and one half to two years:

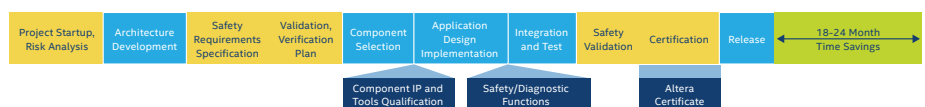

## Accelerating Development

To simplify and speed up the certification process for faster time to market, we worked with TÜV Rheinland and obtained approval for Altera® FPGA devices, IP, our established safety FPGA design flow, and development tools for safety designs up to Safety Integrity Level 3 (SIL3). This certification means that our tools, methodologies, and devices are sufficiently free of systematic errors.

### INTEL FUNCTIONAL SAFETY DATA PACKAGE CONTENTS

FUNCTIONAL DATA SAFETY PACKAGE	BENEFIT
Intel FPGA Development Methodology	Qualified, safe design methodology
Intel FPGA development tools	Qualified tools
Intel IP	Shorter design time, faster debug for safety architecture
Diagnostic IP	Shorter design time, faster debug for safety architecture
Device reliability reports, guidelines	Simplifies risk analysis, failures in time (FIT) calculation
Formatted in compliance with IEC 61508	Seamless integration into product documentation

TÜV Rheinland Certificate  
No. 968/EL 850.00/12

Product Order Numbers  
Functional Safety Data Package:  
IP-ABG-SafetyDP5

Annual Renewal:  
IPR-ABG-SafetyDP5



† Tests measure performance of components on a particular test, in specific systems. Differences in hardware, software, or configuration will affect actual performance. Consult other sources of information to evaluate performance as you consider your purchase. For more complete information about performance and benchmark results, visit [www.intel.com/benchmarks](http://www.intel.com/benchmarks).

© Intel Corporation. Intel, the Intel logo, the Intel Inside mark and logo, the Intel. Experience What's Inside mark and logo, Altera, Arria, Cyclone, Enpirion, Intel Atom, Intel Core, Intel Xeon, MAX, Nios, Quartus and Stratix are trademarks of Intel Corporation or its subsidiaries in the U.S. and/or other countries. See Trademarks on [intel.com](http://intel.com) for full list of Intel trademarks.

\*Other names and brands may be claimed as the property of others.

## Intel FPGAs Provide Flexible Safety Solutions

Figure 1 illustrates a typical industrial controller application. It integrates standard (“non-safe”) and safety functions with very few board components using FPGA devices, such as the Intel Cyclone FPGA, and a soft processor core, such as the Nios II processor. In this example, all three embedded controllers are Nios II soft-core processors, each with an individual custom peripheral set.

With such a safety-focused architecture for a SIL3 certified application, you can reduce the total cost of ownership, design footprint, and power consumption while meeting the global requirements for functional safety.

Architectures where safety typically is an after-thought often use bolt-on safety option boards and dual microcontroller units (MCUs) that detect system failures. Using an option card significantly increases costs. Integrating a SIL3 “safe” solution in a pre-qualified FPGA with standard application functions on the main board not only lowers the safety cost footprint, but it also enhances system flexibility and shortens development time. It is designed with safety as a core system functionality in mind.

If you are concerned about the lack of flexibility, long development times, or device certification issues that come with traditional safety architectures, Intel FPGAs are the ideal solution.

Figure 1. A Typical SIL3 Industrial “Safe” System

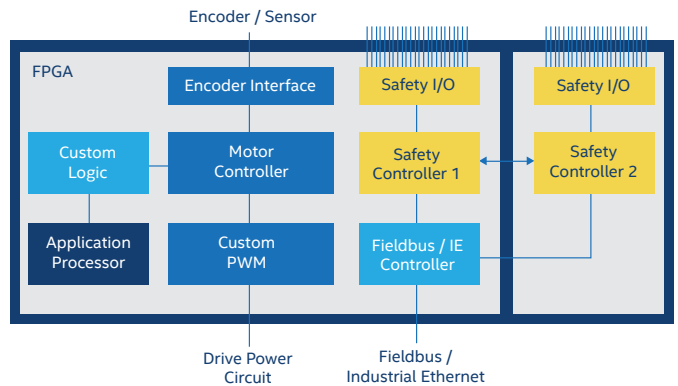

## Learn More

For more information on developing IEC 61508 systems with Intel FPGAs and the Functional Safety Data Package, please contact your local Intel representative, the nearest distributors' sales office or visit the Functional Safety page at [www.intel.com/safety](http://www.intel.com/safety).

## X-ON Electronics

Largest Supplier of Electrical and Electronic Components

*Click to view similar products for [Development Software](#) category:*

*Click to view products by [Intel](#) manufacturer:*

Other Similar products are found below :

[RAPPID-567XFSW](#) [SRP004001-01](#) [SW163052](#) [SYSWINEV21](#) [Core429-SA](#) [WS01NCTF1E](#) [W128E13](#) [SW89CN0-ZCC](#) [IPS-EMBEDDED](#)  
[IP-UART-16550](#) [MPROG-PRO535E](#) [AFLCF-08-LX-CE060-R21](#) [WS02-CFSC1-EV3-UP](#) [SYSMAC-STUDIO-EIPCPLR](#) [LIB-PL-PC-N-](#)  
[1YR-DISKID](#) [LIB-PL-A-F](#) [SW006026-COV](#) [1120270005](#) [1120270006](#) [MIKROBASIC PRO FOR FT90X \(USB DONGLE\)](#) [MIKROC PRO](#)  
[FOR FT90X \(USB DONGLE\)](#) [MIKROC PRO FOR PIC \(USB DONGLE LICENSE\)](#) [MIKROBASIC PRO FOR AVR \(USB DONGLE LICEN](#)  
[MIKROBASIC PRO FOR FT90X](#) [MIKROC PRO FOR DSPIC30/33 \(USB DONGLE LI](#) [MIKROPASCAL PRO FOR ARM \(USB DONGLE](#)  
[LICE](#) [MIKROPASCAL PRO FOR FT90X](#) [MIKROPASCAL PRO FOR FT90X \(USB DONGLE\)](#) [MIKROPASCAL PRO FOR PIC32 \(USB](#)  
[DONGLE LI](#) [SW006021-2H](#) [ATATMELSTUDIO](#) [2400573](#) [2702579](#) [2988609](#) [2702546](#) [SW006022-DGL](#) [2400303](#) [2701356](#) [VDSP-21XX-](#)  
[PCFLOAT](#) [VDSP-BLKFN-PC-FULL](#) [88970111](#) [DG-ACC-NET-CD](#) [55195101-102](#) [SW1A-W1C](#) [MDK-ARM](#) [PCI-EXP1-E3-US](#) [PCI-T32-](#)  
[E3-US](#) [SW006021-2NH](#) [SW006021-1H](#) [SW006021-2](#)