



HDMI Intel® FPGA IP User Guide

Updated for Intel® Quartus® Prime Design Suite: **21.3**

IP Version: **19.6.1**



Online Version



Send Feedback

UG-HDMI

ID: **683798**

Version: **2021.11.12**

Contents

| | |
|---|-----------|
| 1. HDMI Intel® FPGA IP Quick Reference..... | 4 |
| 2. HDMI Overview..... | 6 |
| 2.1. Release Information..... | 12 |
| 2.2. Device Family Support..... | 13 |
| 2.3. Feature Support..... | 14 |
| 2.4. Resource Utilization..... | 14 |
| 3. HDMI Intel FPGA IP Getting Started..... | 17 |
| 3.1. Installing and Licensing Intel FPGA IP Cores..... | 17 |
| 3.1.1. Intel FPGA IP Evaluation Mode..... | 18 |
| 3.2. Specifying IP Parameters and Options..... | 20 |
| 4. HDMI Hardware Design Examples..... | 21 |
| 4.1. HDMI Hardware Design Examples for Intel Arria 10, Intel Cyclone 10 GX, and Intel Stratix 10 Devices..... | 21 |
| 4.2. HDCP Over HDMI Design Example for Intel Arria 10 and Intel Stratix 10 Devices..... | 21 |
| 4.3. HDMI Hardware Design Examples for Arria V and Stratix V Devices..... | 22 |
| 4.3.1. HDMI Hardware Design Components..... | 22 |
| 4.3.2. HDMI Hardware Design Requirements..... | 37 |
| 4.3.3. Design Walkthrough..... | 38 |
| 5. HDMI Source..... | 42 |
| 5.1. Source Functional Description..... | 42 |
| 5.1.1. Source Scrambler, TMDS/TERC4 Encoder..... | 43 |
| 5.1.2. Source Video Resampler..... | 44 |
| 5.1.3. Source Window of Opportunity Generator..... | 46 |
| 5.1.4. Source Auxiliary Packet Encoder..... | 46 |
| 5.1.5. Source Auxiliary Packet Generators..... | 48 |
| 5.1.6. Source Auxiliary Data Path Multiplexers..... | 48 |
| 5.1.7. Source Auxiliary Control Port..... | 48 |
| 5.1.8. Source Audio Encoder..... | 53 |
| 5.1.9. HDCP 1.4 TX Architecture..... | 59 |
| 5.1.10. HDCP 2.3 TX Architecture..... | 63 |
| 5.1.11. FRL Packetizer..... | 69 |
| 5.1.12. FRL Character Block and Super Block Mapping..... | 69 |
| 5.1.13. Reed-Solomon (RS) Forward Error Correction (FEC) Generation and Insertion..... | 69 |
| 5.1.14. FRL Scrambler and Encoder..... | 69 |
| 5.1.15. Source FRL Resampler..... | 69 |
| 5.1.16. TX Oversampler..... | 70 |
| 5.1.17. Clock Enable Generator..... | 70 |
| 5.1.18. I ² C Master..... | 71 |
| 5.2. Source Interfaces..... | 71 |
| 5.3. Source Clock Tree..... | 84 |
| 5.4. Link Training Procedure..... | 87 |
| 5.5. FRL Clocking Scheme..... | 88 |
| 5.6. Valid Video Data..... | 90 |
| 5.7. Source Deep Color Implementation When Support FRL = 0..... | 91 |

| | |
|---|------------|
| 5.8. Source Deep Color Implementation When Support FRL = 1..... | 93 |
| 5.9. Variable Refresh Rate (VRR) and Auto Low Latency Mode (ALLM)..... | 94 |
| 6. HDMI Sink..... | 95 |
| 6.1. Sink Functional Description..... | 95 |
| 6.1.1. Sink Word Alignment and Channel Deskew..... | 96 |
| 6.1.2. Sink Descrambler, TMDS/TERC4 Decoder..... | 99 |
| 6.1.3. Sink Auxiliary Decoder..... | 99 |
| 6.1.4. Sink Auxiliary Packet Capture..... | 100 |
| 6.1.5. Sink Video Resampler..... | 100 |
| 6.1.6. Sink Auxiliary Data Port..... | 101 |
| 6.1.7. Sink Audio Decoder..... | 105 |
| 6.1.8. Status and Control Data Channel (SCDC) Interface..... | 108 |
| 6.1.9. HDCP 1.4 RX Architecture..... | 108 |
| 6.1.10. HDCP 2.3 RX Architecture..... | 114 |
| 6.1.11. FRL Depacketizer..... | 117 |
| 6.1.12. Sink FRL Character Block and Super Block Demapper..... | 118 |
| 6.1.13. Sink FRL Descrambler and Decoder..... | 118 |
| 6.1.14. Sink FRL Resampler..... | 118 |
| 6.1.15. RX Oversampler..... | 118 |
| 6.1.16. I2C Slave..... | 118 |
| 6.1.17. I2C and EDID RAM Blocks..... | 119 |
| 6.1.18. Variable Refresh Rate(VRR) and Auto Low Latency Mode (ALLM)..... | 119 |
| 6.2. Sink Interfaces..... | 119 |
| 6.3. Sink Clock Tree..... | 133 |
| 6.4. Link Training Procedure..... | 135 |
| 6.5. Sink Deep Color Implementation When Support FRL = 0..... | 136 |
| 6.6. Sink Deep Color Implementation When Support FRL = 1..... | 138 |
| 7. HDMI Parameters..... | 140 |
| 7.1. HDMI Source Parameters..... | 140 |
| 7.2. HDMI Sink Parameters..... | 142 |
| 8. HDMI Simulation Example..... | 146 |
| 8.1. Simulation Walkthrough..... | 147 |
| 9. HDMI Intel FPGA IP User Guide Archives..... | 150 |
| 10. Document Revision History for the HDMI Intel FPGA IP User Guide..... | 151 |

1. HDMI Intel® FPGA IP Quick Reference

The Intel® FPGA High-Definition Multimedia Interface (HDMI) IP provides support for next-generation video display interface technology. The HDMI Intel FPGA IP is part of the Intel FPGA IP Library, which is distributed with the Intel Quartus® Prime software.

Note: All information in this document refers to the Intel Quartus Prime Pro Edition software, unless stated otherwise.

| | Information | Description |
|-----------------------|---------------------|---|
| IP Information | Core Features | <ul style="list-style-type: none"> • Conforms to the <i>High-Definition Multimedia Interface (HDMI) Specification versions 1.4, 2.0b, and 2.1</i> • Supports transmitter and receiver on a single device transceiver quad • Supports pixel frequency up to 600 MHz for HDMI 2.0 and 1,200 MHz for HDMI 2.1 • Supports fixed rate link (FRL) for HDMI 2.1 • Supports RGB and YCbCr 444, 422, and 420 color modes • Accepts standard H-SYNC, V-SYNC, data enable, RGB video format, and YCbCr video format • Supports up to 32 audio channels in 2-channel and 8-channel layouts. • Supports 8, 10, 12, or 16 bits per component (bpc) • Supports single link Digital Visual Interface (DVI) • Supports High Dynamic Range (HDR) InfoFrame insertion and filter through the provided design examples • Supports the High-bandwidth Digital Content Protection (HDCP) feature for Intel Arria® 10 and Intel Stratix® 10 devices • Supports Variable Refresh Rate (VRR) and Auto Low Latency Mode (ALLM) for HDMI 2.1 |
| | Typical Application | <ul style="list-style-type: none"> • Interfaces within a PC and monitor • External display connections, including interfaces between a PC and monitor or projector, between a PC and TV, or between a device such as a DVD player and TV display |
| | Device Family | Supports Intel Stratix 10 (H-tile and L-tile), Intel Arria 10, Intel Cyclone® 10 GX, Arria V, and Stratix V FPGA devices <i>Note:</i> HDMI 2.1 with FRL enabled supports only Intel Stratix 10 and Intel Arria 10 devices. |
| | Design Tools | <ul style="list-style-type: none"> • Intel Quartus Prime software for IP design instantiation and compilation • Timing Analyzer in the Intel Quartus Prime software for timing analysis • ModelSim* - Intel FPGA Edition or ModelSim - Intel FPGA Starter Edition, NCSim, Riviera-PRO*, VCS*, VCS MX, and Xcelium* Parallel software for design simulation |

Note: The High-bandwidth Digital Content Protection (HDCP) feature is not included in the Intel Quartus Prime Pro Edition software. To access the HDCP feature, contact Intel at <https://www.intel.com/content/www/us/en/broadcast/products/programmable/applications/connectivity-solutions.html>.

Related Information

- [HDMI Intel Arria 10 FPGA IP Design Example User Guide](#)
For more information about the Intel Arria 10 design examples.
- [HDMI Intel Cyclone 10 GX FPGA IP Design Example User Guide](#)
For more information about the Intel Cyclone 10 GX design examples.
- [HDMI Intel Stratix 10 FPGA IP Design Example User Guide](#)
For more information about the Intel Stratix 10 design examples.
- [Intel Arria 10 HDMI 2.1 System Design Guidelines](#)
For more information about the Intel Arria 10 HDMI 2.1 system design guidelines.
- [HDMI Intel FPGA IP User Guide Archives](#) on page 150
Provides a list of user guides for previous versions of the HDMI Intel FPGA IP.

2. HDMI Overview

The HDMI Intel FPGA IP provides support for next generation video display interface technology.

The HDMI standard specifies a digital communications interface for use in both internal and external connections:

- Internal connections—interface within a PC and monitor
- External display connections—interface between a PC and monitor or projector, between a PC and TV, or between a device such a DVD player and TV display.

The HDMI system architecture consists of sinks and sources. A device may have one or more HDMI inputs and outputs.

The HDMI cable and connectors carry four differential pairs that make up the Transition Minimized Differential Signaling (TMDS) data and clock channels for HDMI 1.4 and HDMI 2.0. For HDMI 2.1, HDMI cable and connectors carry four fixed rate link (FRL) lanes of data. You can use these channels to carry video, audio, and auxiliary data.

The HDMI also carries a Video Electronics Standards Association (VESA) Display Data Channel (DDC) and Status and Control Data Channel (SCDC). The DDC configures and exchanges status between a single source and a single sink. The source uses the DDC to read the sink's Enhanced Extended Display Identification Data (E-EDID) to discover the sink's configuration and capabilities.

The optional Consumer Electronics Control (CEC) protocol provides high-level control functions between various audio visual products in your environment.

The optional HDMI Ethernet and Audio Return Channel (HEAC) provides Ethernet compatible data networking between connected devices and an audio return channel in the opposite direction of TMDS. The HEAC also uses Hot-Plug Detect (HPD) line for link detection.

Figure 1. HDMI Intel FPGA IP Block Diagram for TMDS Mode

The figure below illustrates the blocks in the HDMI Intel FPGA IP for TMDS Mode.

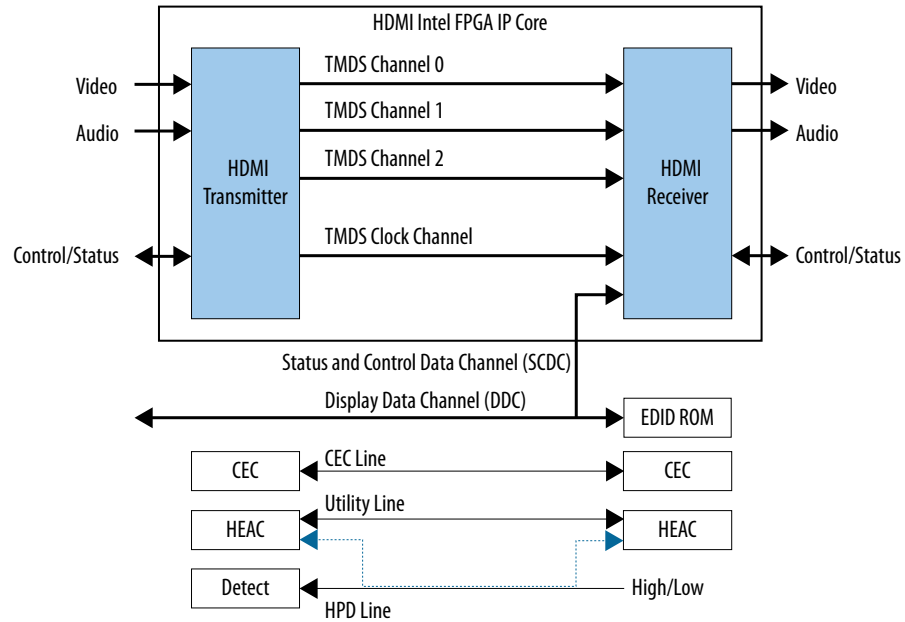

Based on TMDS encoding, the HDMI protocol allows the transmission of both audio and video data between source and sink devices.

An HDMI interface consists of three color channels accompanied by a single clock channel. You can use each color line to transfer both individual RGB colors and auxiliary data.

Note: Refer to *AN 837: Design Guidelines for Intel FPGA HDMI* to know more about the channel mapping to the RGB colors for HDMI 1.4 and HDMI 2.0.

The receiver uses the TMDS clock as a frequency reference for data recovery on the three TMDS data channels. This clock typically runs at the video pixel rate.

TMDS encoding is based on an 8-bit to 10-bit algorithm. This protocol attempts to minimize data channel transition, and yet maintain sufficient transition so that a sink device can lock reliably to the data stream.

Figure 2. Fixed Rate Link (FRL)

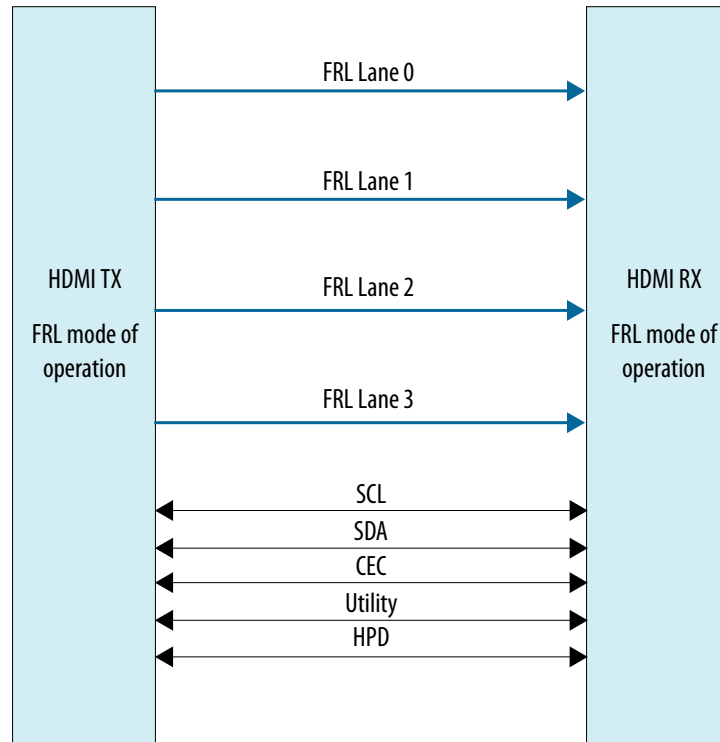

In HDMI 1.4 and HDMI 2.0, 3 lanes carry data and 1 lane carries TMDS clock. When operating in FRL mode, the clock channel carries data as well. As the HDMI 2.1 specification requires backward compatibility with HDMI 1.4 and HDMI 2.0, you need to configure the 4th lane to carry data or clock during run time.

You can configure the FRL mode to 3 lanes and 4 lanes. In 3-lane FRL mode, each lane can operate at 3 Gbps or 6 Gbps. In 4-lane FRL mode, each lane can operate at 6 Gbps, 8 Gbps, 10 Gbps, or 12 Gbps.

Use category 3 (Cat 3) cable for FRL mode to ensure good signal integrity.

Figure 3. HDMI Intel FPGA IP Video Stream Data

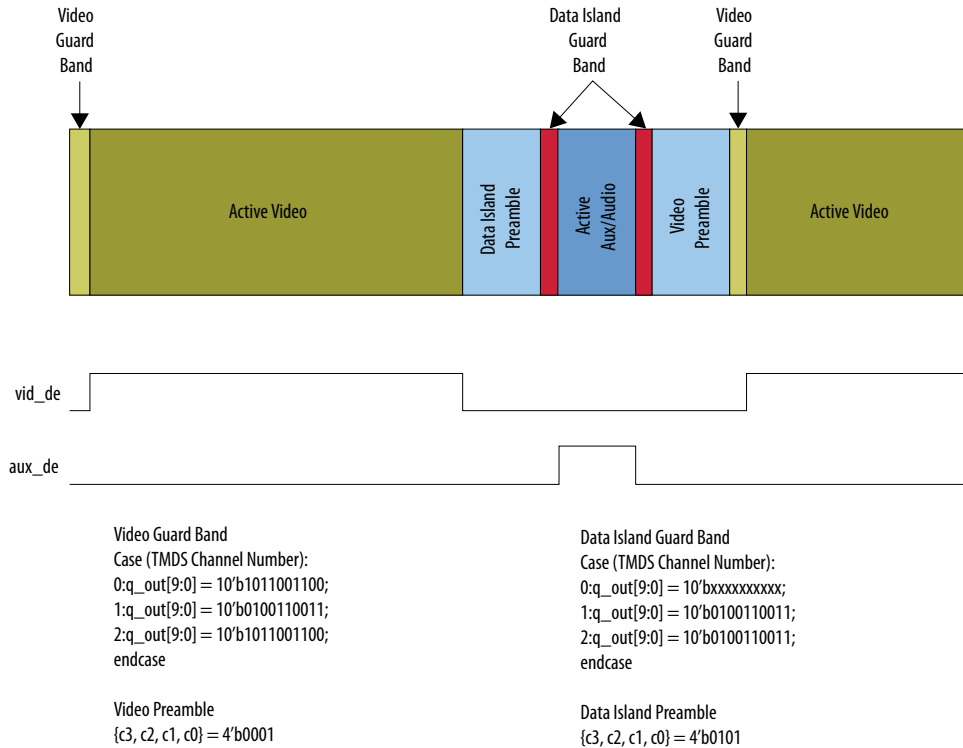

The figure above illustrates two data streams:

- Data stream in green—transports color data
- Data stream in dark blue—transports auxiliary data

Table 1. Video Data and Auxiliary Data

The table below describes the function of the video data and auxiliary data.

| Data | Description |
|----------------|---|
| Video data | <ul style="list-style-type: none"> • Packed representation of the video pixels clocked at the source pixel clock. • Encoded using the TMDS 8-bit to 10-bit algorithm. |
| Auxiliary data | <ul style="list-style-type: none"> • Transfers audio data together with a range of auxiliary data packets. • Sink devices use auxiliary data packets to correctly reconstruct video and audio data. • Encoded using the TMDS Error Reduction Coding–4 bits (TERC4) encoding algorithm. |

Each data stream section is preceded with guard bands and pre-ambles. The guard bands and pre-ambles allow for accurate synchronization with received data streams.

The following figures show the arrangement of the video data, video data enable, video H-SYNC, and video V-SYNC in 1, 2, 4, and 8 pixels per clock.

Figure 4. Video Data, Video Data Valid, H-SYNC, and V-SYNC—1 Pixel per Clock

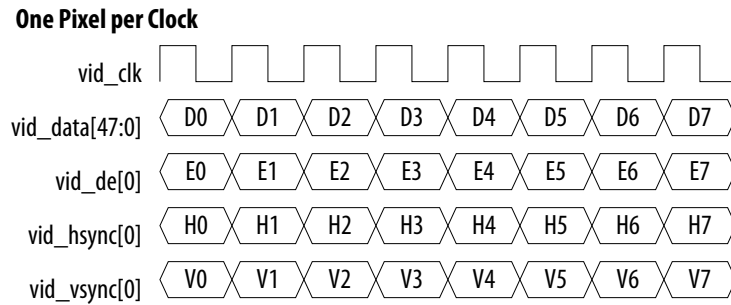

Figure 5. Video Data, Video Data Valid, H-SYNC, and V-SYNC—2 Pixels per Clock

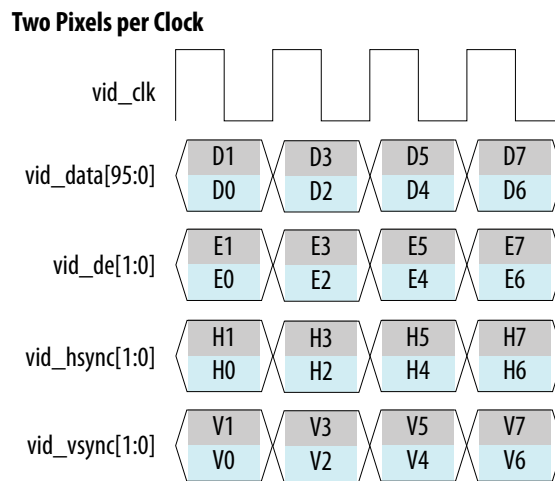

Figure 6. Video Data, Video Data Valid, H-SYNC, and V-SYNC—4 Pixels per Clock

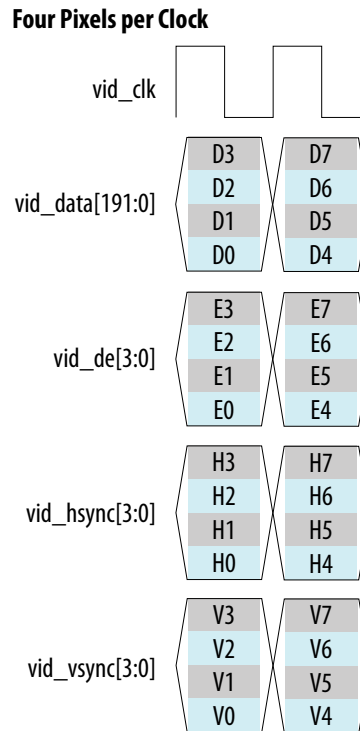
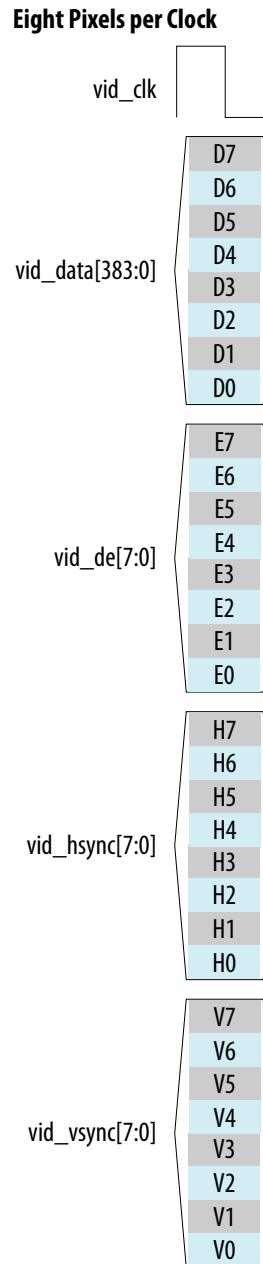

Figure 7. Video Data, Video Data Valid, H-SYNC, and V-SYNC—8 Pixels per Clock



Related Information

[AN 837: Design Guidelines for Intel FPGA HDMI](#)

2.1. Release Information

Intel FPGA IP versions match the Intel Quartus Prime Design Suite software versions until v19.1. Starting in Intel Quartus Prime Design Suite software version 19.2, Intel FPGA IP has a new versioning scheme.

The Intel FPGA IP version (X.Y.Z) number can change with each Intel Quartus Prime software version. A change in:

- X indicates a major revision of the IP. If you update the Intel Quartus Prime software, you must regenerate the IP.
- Y indicates the IP includes new features. Regenerate your IP to include these new features.
- Z indicates the IP includes minor changes. Regenerate your IP to include these changes.

Table 2. HDMI Intel FPGA IP Release Information

| Item | Description |
|-----------------------------|--|
| IP Version | 19.6.1 |
| Intel Quartus Prime Version | 21.3 (Intel Quartus Prime Pro Edition) |
| Release Date | 2021.10.04 |
| Ordering Code | IP-HDMI |

Related Information

[HDMI Intel FPGA IP Release Notes](#)

Describes changes to the IP in a particular release.

2.2. Device Family Support

Table 3. Intel Device Family Support

| Device Family | Support Level |
|--|---------------|
| Intel Stratix 10 (H-tile and L-tile) (Intel Quartus Prime Pro Edition) | Final |
| Intel Arria 10 (Intel Quartus Prime Pro Edition) | Final |
| Intel Cyclone 10 GX (Intel Quartus Prime Pro Edition) | Final |
| Arria V (Intel Quartus Prime Standard Edition) | Final |
| Stratix V (Intel Quartus Prime Standard Edition) | Final |

The following terms define device support levels for Intel FPGA IP cores:

- Advance support—the IP core is available for simulation and compilation for this device family. Timing models include initial engineering estimates of delays based on early post-layout information. The timing models are subject to change as silicon testing improves the correlation between the actual silicon and the timing models. You can use this IP core for system architecture and resource utilization studies, simulation, pinout, system latency assessments, basic timing assessments (pipeline budgeting), and I/O transfer strategy (data-path width, burst depth, I/O standards tradeoffs).
- Preliminary support—the IP core is verified with preliminary timing models for this device family. The IP core meets all functional requirements, but might still be undergoing timing analysis for the device family. It can be used in production designs with caution.
- Final support—the IP core is verified with final timing models for this device family. The IP core meets all functional and timing requirements for the device family and can be used in production designs.

2.3. Feature Support

Table 4. HDMI Intel FPGA IP FRL Feature Support in Intel Stratix 10 and Intel Arria 10 Devices

| Feature | Support Level | |
|-----------------|------------------|-------------|
| Support FRL = 1 | Intel Arria 10 | Final |
| | Intel Stratix 10 | Preliminary |
| Support FRL = 0 | Final | |

The following terms define IP feature support levels for HDMI Intel FPGA IP:

- Preliminary support—The IP meets the functional requirement for the feature set as listed in this user guide. Additional features, characterization, and system level design guidelines shall be covered in future releases. The IP can be used in production designs for the supported device family with caution.
- Final support—The IP is compliant to the protocol CTS requirement for the supported device family and can be used in production design. Characterization report and system level design guidelines are available to facilitate meeting PHY CTS requirements.

2.4. Resource Utilization

The resource utilization data indicates typical expected performance for the HDMI Intel FPGA IP in the Intel Quartus Prime Pro Edition software.

Table 5. HDMI Data Rate

The table lists the maximum data rates for HDMI Intel FPGA IP configurations.

| Devices | Maximum Data Rate (Mbps) | |
|---------------------|---|---|
| | 2 Pixels per Clock (Support FRL = 0) | 8 Pixels per Clock (Support FRL = 1) |
| Intel Stratix 10 | 5,940 (Example: 4Kp60 8 bpc) | 12,000 (Example: 8Kp30 12 bpc) |
| Intel Arria 10 | 5,940 (Example: 4Kp60 8 bpc) | 12,000 (Example: 8Kp30 12 bpc) |
| Intel Cyclone 10 GX | 5,940 (Example: 4Kp60 8 bpc) | Not Supported |

Table 6. HDMI Intel FPGA IP Resource Utilization

The table lists the performance data for the different Intel FPGA devices.

| Device | Pixels per Clock | Direction | ALMs | Logic Registers | | Memory | |
|---|------------------|-----------|--------|-----------------|-----------|---------|--------------|
| | | | | Primary | Secondary | Bits | M10K or M20K |
| Intel Stratix 10 H-tile (Support FRL = 0) (1) | 2 | RX | 5,041 | 6,633 | 902 | 38,400 | 14 |
| | 2 | TX | 4,975 | 7,559 | 1,368 | 37,568 | 13 |
| Intel Stratix 10 L-tile (Support FRL = 0) (1) | 2 | RX | 5,025 | 6,584 | 967 | 38,400 | 14 |
| | 2 | TX | 4,966 | 7,539 | 1,425 | 37,568 | 13 |
| Intel Arria 10 (Support FRL = 0) (1) | 2 | RX | 3,768 | 5,716 | 1,049 | 36,352 | 14 |
| | 2 | TX | 4,445 | 7,016 | 1,701 | 36,968 | 13 |
| Intel Arria 10 (Support FRL = 1) (2) | 8 | RX | 48,865 | 55,417 | 13,067 | 376,832 | 87 |
| | 8 | TX | 30,092 | 35,533 | 6,839 | 276,288 | 60 |
| Intel Cyclone 10 GX | 2 | RX | 4,000 | 5,768 | 965 | 38,400 | 14 |
| | 2 | TX | 4,484 | 7,167 | 1,629 | 36,968 | 13 |

Table 7. Recommended Speed Grades for Intel Stratix 10 and Intel Arria 10 Devices (Support FRL = 1)

| Device | Lane Rate (Mbps) | Transceiver Interface Width (bits) | Speed Grade |
|------------------|------------------|------------------------------------|-------------|
| Intel Stratix 10 | 12,000 | 40 | -1, -2 (3) |
| Intel Arria 10 | 12,000 | 40 | -1, -2 |

- (1) Resource data for Support FRL = 1 design is not finalized.
- (2) Contact Intel Sales for further optimization for specific device variants.
- (3) Contact Intel Sales if you need to use -2 speed grade.

Table 8. Recommended Speed Grades for Intel Stratix 10, Intel Arria 10, and Intel Cyclone 10 GX Devices (Support FRL = 0)

| Device | Lane Rate (Mbps) | Interface Width (bits) | Speed Grades |
|---------------------|------------------|------------------------|--------------|
| Intel Stratix 10 | 6,000 | 20 | -1, -2 |
| Intel Arria 10 | 6,000 | 20 | -1, -2 |
| Intel Cyclone 10 GX | 6,000 | 20 | -5 |

Table 9. HDCP Resource Utilization

The table lists the HDCP resource data for Intel Arria 10 and Intel Stratix 10 devices.

| Device | HDCP IP | Support HDCP Key Management | Support FRL | Pixels/TMDS Symbols Per Clock | ALMs | Combination al ALUTs | Registers | M20K | DSP | |
|----------------|------------------|-----------------------------|-------------|-------------------------------|--------|----------------------|-----------|--------|-----|---|
| Intel Arria 10 | HDCP 2.3 TX | 0 | 0 | 2 | 6,479 | 10,548 | 12,015 | 10 | 3 | |
| | | | 1 | 8 | 16,629 | 28,783 | 23,606 | 10 | 3 | |
| | | 1 | 0 | 2 | 6,875 | 11,338 | 12,793 | 12 | 3 | |
| | | | 1 | 8 | 17,048 | 29,534 | 24,367 | 12 | 3 | |
| | HDCP 2.3 RX | 0 | 0 | 2 | 7,119 | 11,685 | 12,673 | 11 | 3 | |
| | | | 1 | 8 | 17,083 | 30,148 | 24,068 | 11 | 3 | |
| | | 1 | 0 | 2 | 7,543 | 12,420 | 13,406 | 13 | 3 | |
| | | | 1 | 8 | 17,552 | 30,861 | 24,806 | 13 | 3 | |
| | HDCP 1.4 TX | 0 | 0, 1 | 2 | 1,665 | 2,626 | 4,411 | 2 | 0 | |
| | | 1 | 0, 1 | 2 | 2,142 | 3,411 | 5,167 | 4 | 0 | |
| | HDCP 1.4 RX | 0 | 0, 1 | 2 | 1,170 | 1,850 | 3,407 | 3 | 0 | |
| | | 1 | 0, 1 | 2 | 1,616 | 2,558 | 4,207 | 5 | 0 | |
| | Intel Stratix 10 | HDCP 2.3 TX | 0 | 0 | 2 | 7,213 | 11,582 | 12,810 | 10 | 3 |
| | | | | 1 | 8 | 17,755 | 29,784 | 24,428 | 10 | 3 |
| 1 | | | 0 | 2 | 7,888 | 12,473 | 13,188 | 12 | 3 | |
| | | | 1 | 8 | 18,477 | 30,540 | 25,191 | 12 | 3 | |
| HDCP 2.3 RX | | 0 | 0 | 2 | 8,145 | 12,691 | 13,438 | 11 | 3 | |
| | | | 1 | 8 | 18,482 | 30,881 | 25,422 | 11 | 3 | |
| | | 1 | 0 | 2 | 8,644 | 13,382 | 13,640 | 13 | 3 | |
| | | | 1 | 8 | 19,096 | 31,460 | 26,138 | 13 | 3 | |
| HDCP 1.4 TX | | 0 | 0, 1 | 2 | 2,320 | 2,937 | 4,544 | 2 | 0 | |
| | | 1 | 0, 1 | 2 | 2,881 | 3,797 | 5,170 | 4 | 0 | |
| HDCP 1.4 RX | | 0 | 0, 1 | 2 | 1,784 | 2,135 | 3,605 | 3 | 0 | |
| | | 1 | 0, 1 | 2 | 2,293 | 2,897 | 4,219 | 5 | 0 | |

3. HDMI Intel FPGA IP Getting Started

This chapter provides a general overview of the Intel IP core design flow to help you quickly get started with the HDMI Intel FPGA IP. The Intel FPGA IP Library is installed as part of the Intel Quartus Prime installation process. You can select and parameterize any Intel FPGA IP from the library. Intel provides an integrated parameter editor that allows you to customize the HDMI Intel FPGA IP to support a wide variety of applications. The parameter editor guides you through the setting of parameter values and selection of optional ports.

Related Information

- [Introduction to Intel FPGA IP Cores](#)
Provides general information about all Intel FPGA IP cores, including parameterizing, generating, upgrading, and simulating IP cores.
- [Creating Version-Independent IP and Platform Designer Simulation Scripts](#)
Create simulation scripts that do not require manual updates for software or IP version upgrades.
- [Project Management Best Practices](#)
Guidelines for efficient management and portability of your project and IP files.

3.1. Installing and Licensing Intel FPGA IP Cores

The Intel Quartus Prime software installation includes the Intel FPGA IP library. This library provides many useful IP cores for your production use without the need for an additional license. Some Intel FPGA IP cores require purchase of a separate license for production use. The Intel FPGA IP Evaluation Mode allows you to evaluate these licensed Intel FPGA IP cores in simulation and hardware, before deciding to purchase a full production IP core license. You only need to purchase a full production license for licensed Intel IP cores after you complete hardware testing and are ready to use the IP in production.

The Intel Quartus Prime software installs IP cores in the following locations by default:

Figure 8. IP Core Installation Path

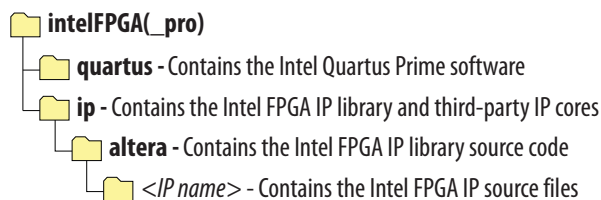

Table 10. IP Core Installation Locations

| Location | Software | Platform |
|---|--------------------------------------|----------|
| <drive>:\intelFPGA_pro\quartus\ip\altera | Intel Quartus Prime Pro Edition | Windows* |
| <drive>:\intelFPGA\quartus\ip\altera | Intel Quartus Prime Standard Edition | Windows |
| <home directory>:\intelFPGA_pro\quartus\ip\altera | Intel Quartus Prime Pro Edition | Linux* |
| <home directory>:\intelFPGA\quartus\ip\altera | Intel Quartus Prime Standard Edition | Linux |

Note: The Intel Quartus Prime software does not support spaces in the installation path.

3.1.1. Intel FPGA IP Evaluation Mode

The free Intel FPGA IP Evaluation Mode allows you to evaluate licensed Intel FPGA IP cores in simulation and hardware before purchase. Intel FPGA IP Evaluation Mode supports the following evaluations without additional license:

- Simulate the behavior of a licensed Intel FPGA IP core in your system.
- Verify the functionality, size, and speed of the IP core quickly and easily.
- Generate time-limited device programming files for designs that include IP cores.
- Program a device with your IP core and verify your design in hardware.

Intel FPGA IP Evaluation Mode supports the following operation modes:

- **Tethered**—Allows running the design containing the licensed Intel FPGA IP indefinitely with a connection between your board and the host computer. Tethered mode requires a serial joint test action group (JTAG) cable connected between the JTAG port on your board and the host computer, which is running the Intel Quartus Prime Programmer for the duration of the hardware evaluation period. The Programmer only requires a minimum installation of the Intel Quartus Prime software, and requires no Intel Quartus Prime license. The host computer controls the evaluation time by sending a periodic signal to the device via the JTAG port. If all licensed IP cores in the design support tethered mode, the evaluation time runs until any IP core evaluation expires. If all of the IP cores support unlimited evaluation time, the device does not time-out.
- **Untethered**—Allows running the design containing the licensed IP for a limited time. The IP core reverts to untethered mode if the device disconnects from the host computer running the Intel Quartus Prime software. The IP core also reverts to untethered mode if any other licensed IP core in the design does not support tethered mode.

When the evaluation time expires for any licensed Intel FPGA IP in the design, the design stops functioning. All IP cores that use the Intel FPGA IP Evaluation Mode time out simultaneously when any IP core in the design times out. When the evaluation time expires, you must reprogram the FPGA device before continuing hardware verification. To extend use of the IP core for production, purchase a full production license for the IP core.

You must purchase the license and generate a full production license key before you can generate an unrestricted device programming file. During Intel FPGA IP Evaluation Mode, the Compiler only generates a time-limited device programming file (<project name>_time_limited.sof) that expires at the time limit.

Figure 9. Intel FPGA IP Evaluation Mode Flow

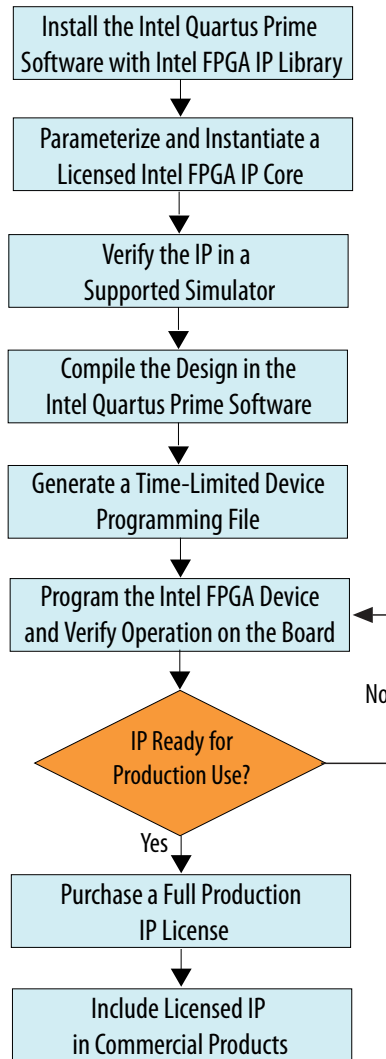

Note: Refer to each IP core's user guide for parameterization steps and implementation details.

Intel licenses IP cores on a per-seat, perpetual basis. The license fee includes first-year maintenance and support. You must renew the maintenance contract to receive updates, bug fixes, and technical support beyond the first year. You must purchase a full production license for Intel FPGA IP cores that require a production license, before generating programming files that you may use for an unlimited time. During Intel FPGA IP Evaluation Mode, the Compiler only generates a time-limited device programming file (`<project name>_time_limited.sof`) that expires at the time limit. To obtain your production license keys, visit the [Self-Service Licensing Center](#).

The [Intel FPGA Software License Agreements](#) govern the installation and use of licensed IP cores, the Intel Quartus Prime design software, and all unlicensed IP cores.

Related Information

- [Intel FPGA Licensing Support Center](#)
- [Introduction to Intel FPGA Software Installation and Licensing](#)

3.2. Specifying IP Parameters and Options

Follow these steps to specify the HDMI Intel FPGA IP parameters and options.

1. Create a Intel Quartus Prime project using the **New Project Wizard** available from the File menu.
2. On the **Tools** menu, click **IP Catalog**.
3. Under **Installed IP**, double-click **Library > Interface > Protocols > Audio&Video > HDMI Intel FPGA IP**. The parameter editor appears.
4. Specify a top-level name for your custom IP variation. This name identifies the IP variation files in your project. If prompted, also specify the targeted FPGA device family and output file HDL preference. Click **OK**.
5. Specify parameters and options in the HDMI parameter editor:
 - Optionally select preset parameter values. Presets specify all initial parameter values for specific applications (where provided).
 - Specify parameters defining the IP functionality, port configurations, and device-specific features.
 - Specify options for generation of a timing netlist, simulation model, testbench, or example design (where applicable).
 - Specify options for processing the IP files in other EDA tools.
6. Click **Generate** to generate the IP and supporting files, including simulation models.
7. Click **Close** when file generation completes.
8. Click **Finish**.
9. If you generate the HDMI Intel FPGA IP instance in a Intel Quartus Prime project, you are prompted to add Intel Quartus Prime IP File (.qip) and Intel Quartus Prime Simulation IP File (.sip) to the current Intel Quartus Prime project.

4. HDMI Hardware Design Examples

Intel offers design examples that you can simulate, compile, and test in hardware.

The implementation of the HDMI Intel FPGA IP on hardware requires additional components specific to the targeted device.

4.1. HDMI Hardware Design Examples for Intel Arria 10, Intel Cyclone 10 GX, and Intel Stratix 10 Devices

The HDMI Intel FPGA IP offers design examples that you can generate through the IP catalog in the Intel Quartus Prime Pro Edition software.

Related Information

- [HDMI Intel Arria 10 FPGA IP Design Example User Guide](#)
For more information about the Intel Arria 10 design examples.
- [HDMI Intel Cyclone 10 GX FPGA IP Design Example User Guide](#)
For more information about the Intel Cyclone 10 GX design examples.
- [HDMI Intel Stratix 10 FPGA IP Design Example User Guide](#)
For more information about the Intel Stratix 10 design examples.
- [Intel Arria 10 HDMI 2.1 System Design Guidelines](#)
For more information about the Intel Arria 10 HDMI 2.1 system design guidelines.

4.2. HDCP Over HDMI Design Example for Intel Arria 10 and Intel Stratix 10 Devices

The High-bandwidth Digital Content Protection (HDCP) over HDMI hardware design example helps you to evaluate the functionality of the HDCP feature and enables you to use the feature in your Intel Arria 10 and Intel Stratix 10 designs.

For detailed information about the HDCP over HDMI design examples, refer to the Intel Arria 10 and Intel Stratix 10 design example user guides.

Note:

The HDCP feature is not included in the Intel Quartus Prime Pro Edition software. To access the HDCP feature, contact Intel at <https://www.intel.com/content/www/us/en/broadcast/products/programmable/applications/connectivity-solutions.html>.

Related Information

- [HDMI Intel Arria 10 FPGA IP Design Example User Guide](#)
For more information about the HDCP over HDMI design example for Intel Arria 10 devices and the security considerations when using the HDCP features.

- [HDMI Intel Stratix 10 FPGA IP Design Example User Guide](#)
For more information about the HDCP over HDMI design example for Intel Stratix 10 devices and the security considerations when using the HDCP features.

4.3. HDMI Hardware Design Examples for Arria V and Stratix V Devices

The HDMI hardware design example helps you evaluate the functionality of the HDMI Intel FPGA IP and provides a starting point for you to create your own design for Arria V and Stratix V devices in the Intel Quartus Prime Standard Edition software.

The design example runs on the following device kits:

- Arria V GX starter kit
- Stratix V GX development kit
- Bitec HDMI HSMC 2.0 Daughter Card Revision 8

Related Information

[AN 837: Design Guidelines for Intel FPGA HDMI](#)

4.3.1. HDMI Hardware Design Components

The demonstration designs instantiate the Video and Image Processing (VIP) Suite IP cores or FIFO buffers to perform a direct HDMI video stream passthrough between the HDMI sink and source.

The hardware demonstration design comprises the following components:

- HDMI sink
 - Transceiver Native PHY (RX)
 - Transceiver PHY Reset Controller (RX)
 - PLL
 - PLL Reconfiguration
 - Multirate Reconfiguration Controller (RX)
 - Oversampler (RX)
 - DCFIFO
- Sink Display Data Channel (DDC) and Status and Control Data Channel (SCDC)
- Transceiver Reconfiguration Controller

- VIP bypass and Audio, Auxiliary and InfoFrame buffers
- Platform Designer system
 - VIP passthrough for HDMI video stream
 - Source SCDC controller
 - HDMI source reconfiguration controller
- HDMI source
 - Transceiver Native PHY (TX)
 - Transceiver fPLL
 - Transceiver PHY Reset Controller (TX)
 - PLL
 - PLL Reconfiguration
 - Oversampler (TX)
 - DCFIFO
 - Clock Enable Generator

Figure 10. HDMI Hardware Design Example Block Diagram

The figure below shows a high level architecture of the design.

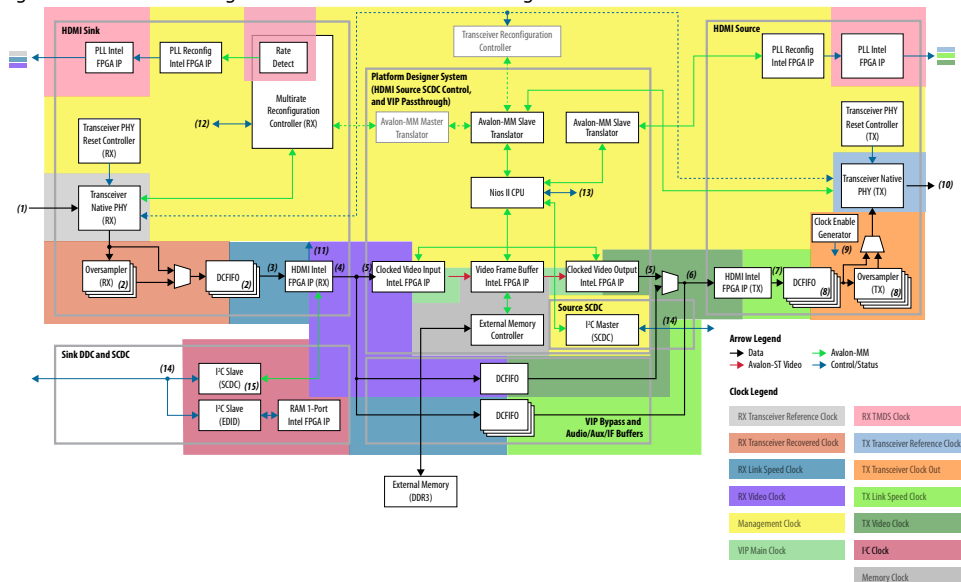

The following details of the design example architecture correspond to the numbers in the block diagram.

1. The sink TMDS data has three channels: data channel 0 (blue), data channel 1 (green), and data channel 2 (red).
2. The Oversampler (RX) and dual-clock FIFO (DCFIFO) instances are duplicated for each TMDS data channel (0,1,2).
3. The video data input width for each color channel of the HDMI RX core is equivalent to RX transceiver PCS-PLD parallel data width per channel.

4. Each color channel is fixed at 16 bpc. The video data output width of the HDMI RX core is equivalent to the value of $\text{symbols per clock} * 16 * 3$.
5. The video data input width of the Clocked Video Input (CVI) and Clocked Video Output (CVO) IP cores are equivalent to the value of $\text{NUMBER_OF_PIXELS_IN_PARALLEL} * \text{BITS_PER_PIXEL_PER_COLOR_PLANE} * \text{NUMBER_OF_COLOR_PLANES}$. To interface with the HDMI core, the values of `NUMBER_OF_PIXELS_IN_PARALLEL`, `BITS_PER_PIXEL_PER_COLOR_PLANE`, and `NUMBER_OF_COLOR_PLANES` must match the symbols per clock, 16 and 3 respectively.
6. The video data input width of the HDMI TX core is equivalent to the value of $\text{symbols per clock} * 16 * 3$. You can use the user switch to select the video data from the CVO IP core (VIP passthrough) or DCFIFO (VIP bypass).
7. The video data output width for each color channel of the HDMI TX core is equivalent to TX transceiver PCS-PLD parallel data width per channel.
8. The DCFIFO and the Oversampler (TX) instances are duplicated for each TMDS data channel (0,1,2) and clock channel.
9. The Oversampler (TX) uses the clock enable signal to read data from the DCFIFO.
10. The source TMDS data has four channels: data channel 0 (blue), data channel 1 (green), data channel 2 (red), and clock channel.
11. The RX Multirate Reconfiguration Controller requires the status of `TMDS_Bit_clock_Ratio` port to perform appropriate RX reconfiguration between the TMDS character rates below 340 Mcsc (HDMI 1.4b) and above 340 Mcsc (HDMI 2.0b). The status of the port is also required by the Nios II processor and the HDMI TX core to perform appropriate TX reconfiguration and scrambling.
12. The reset control and lock status signals from HDMI PLL, RX Transceiver Reset Controller and HDMI RX core.
13. The reset and oversampling control signals for HDMI PLL, TX Transceiver Reset Controller, and HDMI TX core. The lock status and rate detection measure valid signals from the HDMI sink initiate the TX reconfiguration process.
14. The I²C SCL and SDA lines with tristate buffer for bidirectional configuration. Use the ALTIIOBUF IP core for Arria V and Stratix V devices.
15. The SCDC is mainly designed for the source to update the `TMDS_Bit_Clock_Ratio` and `Scrambler_Enable` bits of the sink TMDS Configuration register. .

4.3.1.1. Transceiver Native PHY (RX)

- Transceiver Native PHY in Arria V devices
 - To operate the TMDS bit rate up to 3,400 Mbps, configure the Transceiver Native PHY at 20 bits at PCS – PLD interface with the HDMI RX core at 2 symbols per clock. When the PCS – PLD interface width is 20 bits, the minimum link rate is 611 Mbps.
 - To operate the TMDS bit rate up to 6,000 Mbps, configure the Transceiver Native PHY at 40 bits with the HDMI RX core at 4 symbols per clock. When the PCS – PLD interface width is 40 bits, the minimum link rate is 1,000 Mbps.
 - Oversampling is required for TMDS bit rate which is below the minimum link rate.
- Transceiver Native PHY in Stratix V devices
 - To operate the TMDS bit rate up to 6,000 Mbps, configure the Transceiver Native PHY at 20 bits at PCS – PLD interface with the HDMI RX core at 2 symbols per clock. When the PCS – PLD interface width is 20 bits, the minimum link rate is 611 Mbps.

Table 11. Arria V and Stratix V Transceiver Native PHY (RX) Configuration Settings (6,000 Mbps)

This table shows an example of Arria V and Stratix V Transceiver Native PHY (RX) configuration settings for TMDS bit rate of 6,000 Mbps.

| Parameters | Settings |
|--|------------------|
| Datapath Options | |
| Enable TX datapath | Off |
| Enable RX datapath | On |
| Enable Standard PCS | On |
| Initial PCS datapath selection | Standard |
| Number of data channels | 3 |
| Enable simplified data interface | On |
| RX PMA | |
| Data rate | 6,000 Mbps |
| Enable CDR dynamic reconfiguration | On |
| Number of CDR reference clocks | 2 ⁽⁴⁾ |
| Selected CDR reference clock | 0 ⁽⁴⁾ |
| Selected CDR reference clock frequency | 600 MHz |
| PPM detector threshold | 1,000 PPM |
| <i>continued...</i> | |

⁽⁴⁾ The Bitec HDMI HSMC 2.0 daughter card routes the TMDS clock pin to the transceiver serial data pin. To use the TMDS clock to drive the HDMI PLL, the TMDS clock must also drive the transceiver dedicated reference clock pin. The number of CDR reference clocks is 2 with reference clock 1 (unused) driven by the TMDS clock and reference clock 0 driven by the HDMI PLL output clock. The selected CDR reference clock will be fixed at 0.

| RX PMA | |
|---|----|
| Enable rx_pma_clkout port | On |
| Enable rx_is_lockedtodata port | On |
| Enable rx_is_lockedtoref port | On |
| Enable rx_set_locktodata and rx_set_locktoref ports | On |

| Standard PCS | |
|----------------------------------|---|
| Standard PCS protocol | Basic |
| Standard PCS/PMA interface width | <ul style="list-style-type: none"> 10 (for 1 symbol per clock) 20 (for 2 and 4 symbols per clock) |
| Enable RX byte deserializer | <ul style="list-style-type: none"> Off (for 1 and 2 symbols per clock) On (for 4 symbols per clock) |

Table 12. Arria V and Stratix V Transceiver Native PHY (RX) Common Interface Ports

This table describes the Arria V and Stratix V Transceiver Native PHY (RX) common interface ports.

| Signals | Direction | Description |
|---------------------|-----------|---|
| Clocks | | |
| rx_cdr_refclk[1:0] | Input | Input reference clock for the RX CDR circuitry. <ul style="list-style-type: none"> To support arbitrary wide data rate range from 250 Mbps to 6,000 Mbps, you need a generic core PLL to obtain a higher clock frequency from the TMDS clock. You need a higher clock frequency to create oversampled stream for data rates below the minimum transceiver data rate—for example, 611 Mbps or 1,000 Mbps). If the TMDS clock pin is routed to the transceiver dedicated reference clock pin, you only need to create one transceiver reference clock input. You can use the TMDS clock as reference clock for a generic core PLL to drive the transceiver. If you use Bitec HDMI HSMC 2.0 daughter card, the TMDS clock pin is routed to the transceiver serial data pin. In this case, to use the TMDS clock as a reference clock for a generic core PLL, the clock must also drive the transceiver dedicated reference clock. Connect bit 0 to the generic core PLL output and bit 1 to the TMDS clock and set the selected CDR reference clock at 0. |
| rx_std_clkout[2:0] | Output | RX parallel clock output. <ul style="list-style-type: none"> The CDR circuitry recovers the RX parallel clock from the RX data stream when the CDR is configured at lock-to-data mode. The RX parallel clock is a mirror of the CDR reference clock when the CDR is configured at lock-to-reference mode. |
| rx_std_coreclk[2:0] | Input | RX parallel clock that drives the read side of the RX phase compensation FIFO. Connect to rx_std_clkout ports. |
| rx_pma_clkout[2:0] | Output | RX parallel clock (recovered clock) output from PMA. Leave unconnected. |
| Resets | | |
| rx_analogreset[2:0] | Input | Active-high, edge-sensitive, asynchronous reset signal. |
| <i>continued...</i> | | |

| Resets | | |
|----------------------|-------|---|
| | | When asserted, resets the RX CDR circuit, deserializer. Connect to Transceiver PHY Reset Controller IP core. |
| rx_digitalreset[2:0] | Input | Active-high, edge-sensitive, asynchronous reset signal. When asserted, resets the digital component of the RX data path. Connect to the Transceiver PHY Reset Controller IP core. |

| PMA Ports | | |
|-------------------------|--------|---|
| rx_set_locktoref[2:0] | Input | When asserted, programs the RX CDR to lock to reference mode manually. The lock to reference mode enables you to control the reset sequence using rx_set_locktoref and rx_set_locktodata. The Multirate Reconfiguration Controller (RX) sets this port to 1 if oversampling mode is required. Otherwise, this port is set to 0. Refer "Transceiver Reset Sequence" in Transceiver Reset Control in Arria V/Stratix V Devices for more information about manual control of the reset sequence. |
| rx_set_locktodata[2:0] | Input | Always driven to 0. When rx_set_locktoref is driven to 1, the CDR is configured to lock-to-reference mode. Otherwise, the CDR is configured to lock-to-data mode. |
| rx_is_lockedtoref[2:0] | Output | When asserted, the CDR is locked to the incoming reference clock. Connect this port to rx_is_lockedtodata port of the Transceiver PHY Reset Controller IP core when rx_set_locktoref is 1. |
| rx_is_lockedtodata[2:0] | Output | When asserted, the CDR is locked to the incoming data. Connect this port to rx_is_lockedtodata port of Transceiver PHY Reset Controller IP core when rx_set_locktoref is 0. |
| rx_serial_data[2:0] | Input | RX differential serial input data. |

| PCS Ports | | |
|------------------------------|--------|--|
| unused_rx_parallel_data | Output | Leave unconnected. |
| rx_parallel_data[S*3*10-1:0] | Output | PCS RX parallel data. <i>Note:</i> S=Symbols per clock. |

| Calibration Status Port | | |
|-------------------------|--------|--|
| rx_cal_busy[2:0] | Output | When asserted, indicates that the initial RX calibration is in progress. This port is also asserted if the reconfiguration controller is reset. Connect to the Transceiver PHY Reset Controller IP core. |

| Reconfiguration Ports | | |
|---------------------------|--------|--|
| reconfig_to_xcvr[209:0] | Input | Reconfiguration signals from the Transceiver Reconfiguration Controller. |
| reconfig_from_xcvr[137:0] | Output | Reconfiguration signals to the Transceiver Reconfiguration Controller. |

4.3.1.2. PLL Intel FPGA IP Cores

Use the PLL Intel FPGA IP core as the HDMI PLL to generate reference clock for RX or TX transceiver, link speed, and video clocks for the HDMI RX or TX IP core.

The HDMI PLL is referenced by the arbitrary TMDS clock. For HDMI source, you can reference the HDMI PLL by a separate clock source in the VIP passthrough design, which contains frame buffer. The HDMI PLL for TX has the same desired output frequencies as RX across symbols per clock and color depth.

- For TMDS bit rates ranging from 3,400 Mbps to 6,000 Mbps (HDMI 2.0), the TMDS clock rate is 1/40 of the TMDS bit rate. The HDMI PLL generates reference clock for RX/TX transceiver at 4 times the TMDS clock.
- For TMDS bit rates below 3,400 Mbps (HDMI 1.4b), the TMDS clock rate is 1/10 of the TMDS bit rate. The HDMI PLL generates reference clock for RX/TX transceiver at identical rate as the TMDS clock.

If the TMDS link operates at TMDS bit rates below the minimum RX/TX transceiver link rate, your design requires oversampling and a factor of 5 is chosen. The minimum link rate of the RX/TX transceiver vary across device families and symbols per clock. The HDMI PLL generates reference clock for RX/TX transceiver at 5 times the TMDS clock.

Note: Place the PLL Intel FPGA block on the transmit path (`p11_hdmi_tx`) in the physical location next to the transceiver PLL.

Table 13. HDMI PLL Desired Output Frequencies for 8-bpc Video

This table shows an example of HDMI PLL desired output frequencies across various TMDS clock rates and symbols per clock for all supported device families using 8-bpc video.

| Device Family | Symbols Per Clock | Minimum Link Rate (Mbps) | TMDS Bit Rate (Mbps) | Oversampling (5x) Required | TMDS Clock Rate (MHz) | RX/TX Transceiver Refclk (MHz) | RX/TX Link Speed Clock (MHz) | RX/TX Video Clock (MHz) |
|---------------|-------------------|--------------------------|----------------------|----------------------------|-----------------------|--------------------------------|------------------------------|-------------------------|
| Arria V | 2 | 611 | 270 | Yes | 27 | 135 | 13.5 | 13.5 |
| | | | 742.5 | No | 74.25 | 74.25 | 37.125 | 37.125 |
| | | | 1,485 | No | 148.5 | 148.5 | 74.25 | 74.25 |
| | | | 2,970 | No | 297 | 297 | 148.5 | 148.5 |
| | 4 | 1,000 | 270 | Yes | 27 | 135 | 6.75 | 6.75 |
| | | | 742.5 | Yes | 74.25 | 371.25 | 18.5625 | 18.5625 |
| | | | 1,485 | No | 148.5 | 148.5 | 37.125 | 37.125 |
| | | | 5,940 | No | 148.5 | 594 | 148.5 | 148.5 |
| Stratix V | 2 | 611 | 540 | Yes | 54 | 270 | 27 | 27 |
| | | | 1,620 | No | 162 | 162 | 81 | 81 |
| | | | 5,934 | No | 148.35 | 593.4 | 296.7 | 296.7 |

The color depths greater than 8 bpc or 24 bpp are defined to be deep color. For a color depth of 8 bpc, the core carries the pixels at a rate of one pixel per TMDS clock. At deeper color depths, the TMDS clock runs faster than the source pixel clock to provide the extra bandwidth for the additional bits.

The TMDS clock rate is increased by the ratio of the pixel size to 8 bits:

- 8 bits mode—TMDS clock = $1.0 \times$ pixel or video clock (1:1)
- 10 bits mode—TMDS clock = $1.25 \times$ pixel or video clock (5:4)
- 12 bits mode—TMDS clock = $1.5 \times$ pixel or video clock (3:2)
- 16 bits mode—TMDS clock = $2 \times$ pixel or video clock (2:1)

Table 14. HDMI PLL Desired Output Frequencies for Deep Color Video

This table shows an example of HDMI PLL desired output frequencies across symbols per clock and color depths.

| Symbols Per Clock | Oversampling (5x) Required | Bits Per Component | TMDS Bit Rate (Mbps) ⁽⁵⁾ | TMDS Clock Rate (MHz) | RX/TX Transceiver Refclk (MHz) | RX/TX Link Speed Clock (MHz) | RX/TX Video Clock (MHz) |
|-------------------|----------------------------|--------------------|-------------------------------------|-----------------------|--------------------------------|------------------------------|-------------------------|
| 2 | Yes | 8 | 270 | 27 | 135 | 13.5 | 13.5 |
| | | 10 ⁽⁶⁾ | 337.5 | 33.75 | 168.75 | 16.875 | 13.5 |
| | | 12 ⁽⁶⁾ | 405 | 40.5 | 202.5 | 20.25 | 13.5 |
| | | 16 ⁽⁶⁾ | 540 | 54 | 270 | 27 | 13.5 |
| 4 | No | 8 | 1,485 | 148.5 | 148.5 | 37.125 | 37.125 |
| | | 10 ⁽⁶⁾ | 1,856.25 | 185.625 | 185.625 | 46.40625 | 37.125 |
| | | 12 ⁽⁶⁾ | 2,227.5 | 222.75 | 222.75 | 55.6875 | 37.125 |
| | | 16 ⁽⁶⁾ | 2,970 | 297 | 297 | 74.25 | 37.125 |

The default frequency setting of the HDMI PLL is fixed at possible maximum value for each clock for appropriate timing analysis.

Note: This default combination is not valid for any HDMI resolution. The core will reconfigure to the appropriate settings upon power up.

4.3.1.3. PLL Reconfig Intel FPGA IP Core

The PLL Reconfig Intel FPGA IP core facilitates dynamic real-time reconfiguration of PLLs in Intel FPGAs.

Use the IP core to update the output clock frequency, PLL bandwidth in real-time, without reconfiguring the entire FPGA.

You can run this IP core at 100 MHz in Stratix V devices. In Arria V devices, you need to run at 75 MHz for timing closure. To simplify clocking in Arria V devices, the entire management clock domain is capped at 75 MHz.

⁽⁵⁾ The TMDS bit rate is 10x the TMDS character rate. For information about how the TMDS character rate is derived from the pixel clock rate, refer to the *HDMI Specifications*.

⁽⁶⁾ For this release, deep color video is only demonstrated in VIP bypass mode. It is not available in VIP passthrough mode.

4.3.1.4. Multirate Reconfig Controller (RX)

The Multirate Reconfig Controller implements rate detection circuitry with the HDMI PLL to drive the RX transceiver to operate at any arbitrary link rates ranging from 250 Mbps to 6,000 Mbps. Link rate of 6,000 Mbps is not the absolute maximum but the intention is to support HDMI 2.0b link rate.

The Multirate Reconfig Controller performs rate detection on the HDMI PLL arbitrary reference clock, which is also the TMDS clock, to determine the clock frequency band. Based on the detected clock frequency band, the circuitry dynamically reconfigures the HDMI PLL and transceiver settings to accommodate for the link rate change.

Figure 11. Multirate Reconfiguration Sequence Flow

This figure illustrates the multirate reconfiguration sequence flow of the controller when it receives input data stream and reference clock frequency, or when the transceiver is unlocked.

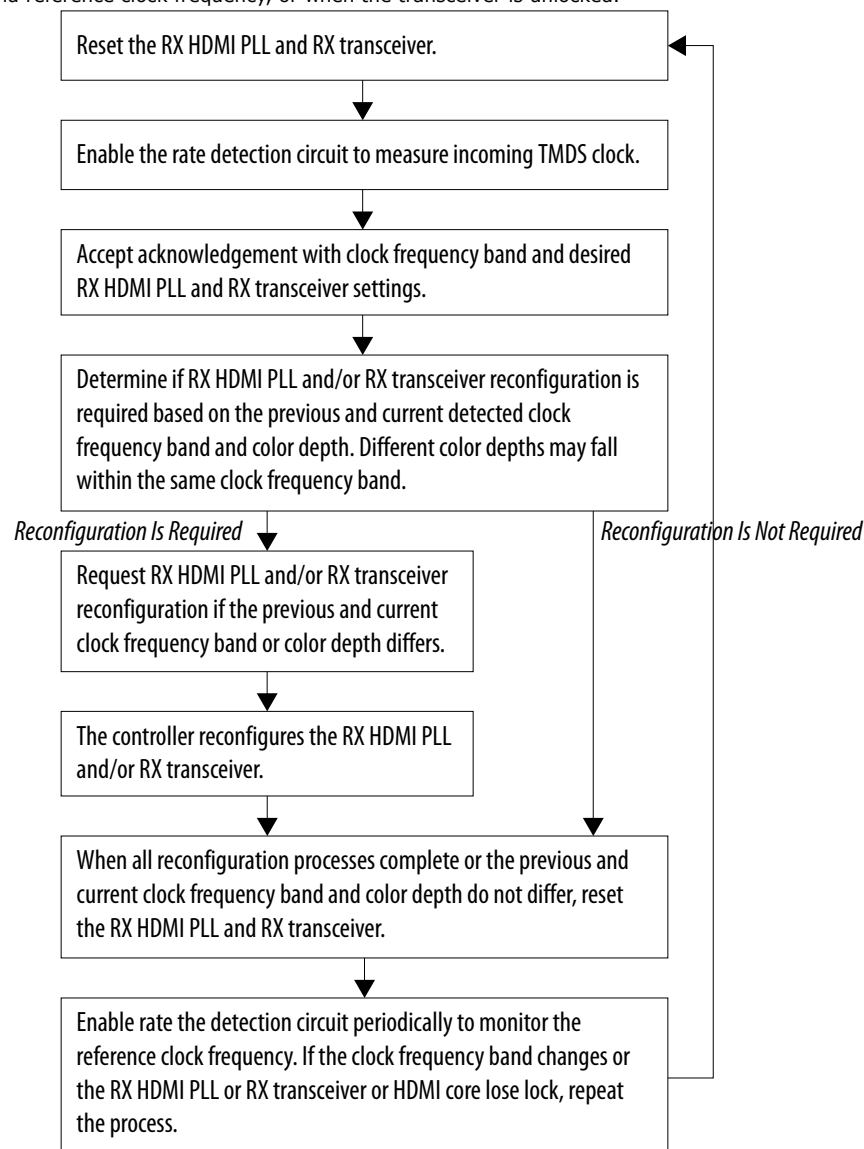

4.3.1.5. Oversampler (RX)

The Oversampler (RX) extracts data from the oversampled incoming data stream when the detected clock frequency band is below the transceiver minimum link rate.

The oversampling factor is fixed at 5 and you can program the data width to support different number of symbols. The supported data width is 20 bit for 2 symbols per clock and 40 bits for 4 symbols per clock. The extracted bit will be accompanied by data valid pulse which asserts every 5 clock cycles.

4.3.1.6. DCFIFO

The DCFIFO transfers data from the RX transceiver recovered clock domain to the RX link speed clock domain. The DCFIFO transfers data from the TX link speed clock domain to the TX transceiver parallel clock out domain.

- Sink
 - When the Multirate Reconfig Controller (RX) detects an incoming input stream that is below the transceiver minimum link rate, the DCFIFO accepts the data from the Oversampler with data valid pulse as write request asserted every 5 clock cycles.
 - Otherwise, it accepts data directly from the transceiver with write request asserted at all times.
- Source
 - When Nios II processor determines the outgoing data stream is below the TX transceiver minimum link rate, the TX transceiver accepts the data from the Oversampler (TX).
 - Otherwise, the TX transceiver reads data directly from the DCFIFO with read request asserted at all times.

4.3.1.7. Sink Display Data Channel (DDC) & Status and Control Data Channel (SCDC)

The HDMI source uses the DDC to determine the capabilities and characteristics of the sink by reading the Enhanced Extended Display Identification Data (E-EDID) data structure.

The E-EDID memory is stored using the RAM 1-Port IP core. A standard two-wire (clock and data) serial data bus protocol (I2C slave-only controller) is used to transfer CEA-861-D compliant E-EDID data structure.

The 8-bit I²C slave addresses for the E-EDID are 0xA0/0xA1. The LSB indicates the access type: 1 for read and 0 for write. When an HPD event occurs, the I²C slave responds to E-EDID data by reading from the RAM.

The I²C slave-only controller is also used to support SCDC for HDMI 2.0b operation. The 8-bit I²C slave addresses for the SCDC are 0xA8/0xA9. When an HPD event occurs, the I²C slave performs write/read transaction to/from SCDC interface of HDMI RX core. This I²C slave-only controller for SCDC is not required if HDMI 2.0b is not intended.

4.3.1.8. Transceiver Reconfiguration Controller

You can use the Transceiver Reconfiguration Controller IP core to change the device transceiver settings at any time.

You can selectively reconfigure any portion of the transceiver. The reconfiguration of each portion requires a read-modify-write operation (read first, then write). The read-modify-write operation modifies only the appropriate bits in a register and does not affect the other bits.

The Transceiver Reconfiguration Controller is only available and required in Arria V and Stratix V devices. Because the RX and TX transceivers share a single controller, the controller requires Platform Designer interconnects, such as Avalon-MM Master Translator and Avalon-MM Slave Translator, in the Platform Designer system.

- The Avalon-MM Master Translator provides an interface between this controller and the RX Multirate Reconfig Controller.
- The Avalon-MM Slave Translator arbitrates the RX and TX reconfiguration event for this controller.

4.3.1.9. VIP Bypass and Audio, Auxiliary and InfoFrame Buffers

The video data output and synchronization signals from HDMI RX core is looped through a DCFIFO across RX and TX video clock domains. The General Control Packet (GCP), InfoFrames (AVI, VSI, and AI), auxiliary data and audio data are looped through DCFIFOs across RX and TX link speed clock domains.

The auxiliary data port of the HDMI TX core controls the auxiliary data that flow through DCFIFO through backpressure. The backpressure ensures there is no incomplete auxiliary packet on the auxiliary data port. This block also performs external filtering on the audio data and audio clock regeneration packet from the auxiliary data stream before sending to the HDMI TX core auxiliary data port.

4.3.1.10. Transceiver Native PHY (TX)

The Arria V and Stratix V Transceiver Native PHY (TX) configuration settings are typically the same as RX.

Table 15. Arria V and Stratix V Transceiver Native PHY (TX) Configuration Settings (6,000 Mbps)

This table shows an example of Arria V and Stratix V Transceiver Native PHY (TX) configuration settings for TMDS bit rate of 6,000 Mbps.

| Parameters | Settings |
|----------------------------------|----------|
| Datapath Options | |
| Enable TX datapath | On |
| Enable RX datapath | Off |
| Enable Standard PCS | On |
| Initial PCS datapath selection | Standard |
| Number of data channels | 4 |
| Bonding mode | xN |
| Enable simplified data interface | On |

| TX PMA | |
|---------------------------------------|------------|
| Data rate | 6,000 Mbps |
| TX local clock division factor | 1 |
| Enable TX PLL dynamic reconfiguration | On |
| Use external TX PLL | Off |
| Number of TX PLLs | 1 |
| Main TX PLL logical index | 0 |
| Number of TX PLL reference clocks | 1 |
| PLL type | CMU |
| Reference clock frequency | 600 MHz |
| Selected reference clock source | 0 |
| Selected clock network | xN |

| Standard PCS | |
|----------------------------------|---|
| Standard PCS protocol | Basic |
| Standard PCS/PMA interface width | <ul style="list-style-type: none"> 10 (for 1 symbol per clock) 20 (for 2 and 4 symbols per clock) |
| Enable TX byte serializer | <ul style="list-style-type: none"> Off (for 1 and 2 symbols per clock) On (for 4 symbols per clock) |

Table 16. Arria V and Stratix V Transceiver Native PHY (TX) Common Interface Ports

This table describes the Arria V and Stratix V Transceiver Native PHY (TX) common interface ports.

| Signals | Direction | Description |
|------------------------|-----------|---|
| Clocks | | |
| tx_pll_refclk | Input | The reference clock input to the TX PLL. |
| tx_std_clkout[3:0] | Output | TX parallel clock output. |
| tx_std_coreclkkin[3:0] | Input | TX parallel clock that drives the write side of the TX phase compensation FIFO. Connect to tx_std_clkout[0] ports. |
| Resets | | |
| tx_analogreset[3:0] | Input | When asserted, resets all the blocks in TX PMA. Connect to Transceiver PHY Reset Controller (TX) IP core. |
| tx_digitalreset[3:0] | Input | When asserted, resets all the blocks in TX PCS. Connect to the Transceiver PHY Reset Controller (TX) IP core. |
| TX PLL | | |
| pll_powerdown | Input | When asserted, resets the TX PLL. Connect to the Transceiver PHY Reset Controller (TX) IP core. |
| pll_locked | Output | When asserted, indicates that the TX PLL is locked. Connect to the Transceiver PHY Reset Controller (TX) IP core. |

| PCS Ports | | |
|------------------------------|--------|---|
| unused_tx_parallel_data | Input | Leave unconnected. |
| tx_parallel_data[S*4*10-1:0] | Input | PCS TX parallel data. <i>Note:</i> S=Symbols per clock. |
| PMA Port | | |
| tx_serial_data[3:0] | Output | TX differential serial output data. |
| Calibration Status Port | | |
| tx_cal_busy[3:0] | Output | When asserted, indicates that the initial TX calibration is in progress. This port is also asserted if the reconfiguration controller is reset. Connect to the Transceiver PHY Reset Controller (TX) IP core. |
| Reconfiguration Ports | | |
| reconfig_to_xcvr[349:0] | Input | Reconfiguration signals from the Transceiver Reconfiguration Controller. |
| reconfig_from_xcvr[229:0] | Output | Reconfiguration signals to the Transceiver Reconfiguration Controller. |

4.3.1.11. Transceiver PHY Reset Controller

The Transceiver PHY Reset Controller IP core ensures a reliable initialization of the RX and TX transceivers.

The reset controller has separate reset controls per channel to handle synchronization of reset inputs, lagging of PLL locked status, and automatic or manual reset recovery mode.

4.3.1.12. Oversampler (TX)

The Oversampler (TX) transmits data by repeating each bit of the input word a given number of times and constructs the output words.

The oversampling factor is fixed at 5. The Oversampler (TX) assumes that the input word is only valid every 5 clock cycles. This block enables when the outgoing data stream is determined to be below the TX transceiver minimum link rate by reading once from the DCFIFO every 5 clock cycles.

4.3.1.13. Clock Enable Generator

The Clock Enable Generator is a logic that generates a clock enable pulse.

This clock enable pulse asserts every 5 clock cycles and serves as a read request signal to clock the data out from DCFIFO.

4.3.1.14. Platform Designer System

The Platform Designer system consists of the VIP passthrough for HDMI video stream, source SDC controller, and source reconfiguration controller blocks.

4.3.1.14.1. VIP Passthrough for HDMI Video Stream

For certain example designs, you can loop the video data output and synchronization signals from HDMI RX core through the VIP data path.

The Clocked Video Input II (CVI II) Intel FPGA IP core converts clocked video formats to Avalon-ST video by stripping incoming clocked video of horizontal and vertical blanking, leaving only active picture data.

- The IP core provides clock crossing capabilities to allow video formats running at different frequencies to enter the system.
- The IP core also detects the format of the incoming clocked video and provides this information in a set of registers.
- The Nios II processor uses this information to reconfigure the video frame mode registers of the CVO IP core in the VIP passthrough design.

The Video Frame Buffer II Intel FPGA IP core buffers video frames into external RAM.

- The IP core supports double and triple buffering with a range of options for frame dropping and repeating.
- You can use the buffering options to solve throughput issues in the data path and perform simple frame rate conversion.

In a VIP passthrough design, you can reference the HDMI source PLL and sink PLL using separate clock sources. However, in a VIP bypass design, you must reference the HDMI source PLL and sink PLL using the same clock source.

The Clocked Video Output II (CVO II) Intel FPGA IP core converts data from the flow-controlled Avalon-ST video protocol to clocked video.

- The IP core provides clock crossing capabilities to allow video formats running at different frequencies to be created from the system.
- It formats the Avalon-ST video into clocked video by inserting horizontal and vertical blanking and generating horizontal and vertical synchronization information using the Avalon-ST video control and active picture packets.
- The video frame is described using the mode registers that are accessed through the Avalon-MM control port.

Table 17. Difference between VIP Passthrough Design and VIP Bypass Design

| VIP Passthrough Design | VIP Bypass Design |
|--|--|
| <ul style="list-style-type: none"> • Can reference the HDMI source PLL and sink PLL using separate clock sources • Demonstrates only certain video formats—640×480p60, 720×480p60, 1280×720p60, 1920×1080p60, and 3840×2160p24 | <ul style="list-style-type: none"> • Must reference the HDMI source PLL and sink PLL using the same clock source • Demonstrates all video formats. |

Table 18. VIP Passthrough and VIP Bypass Options for the Supported Devices

| Device Family | Symbols Per Clock | HDMI Specification Support | Bitenc HDMI HSMC 2.0 Daughter Card | Directory | VIP Passthrough | VIP Bypass |
|---------------|-------------------|----------------------------|------------------------------------|-------------|-----------------|------------|
| Arria V | 2 | 1.4b | HSMC (Rev8) | av_sk | Supported | Supported |
| | 4 | 2.0b | HSMC (Rev8) | av_sk_hdmi2 | Not supported | Supported |
| Stratix V | 2 | 2.0b | HSMC (Rev8) | sv_hdmi2 | Not supported | Supported |

4.3.1.14.2. Source SCDC Controller

The source SCDC Controller contains the I²C master controller. The I²C master controller transfers the SCDC data structure from the FPGA source to the external sink for HDMI 2.0b operation.

For example, if the outgoing data stream is 6,000 Mbps, the Nios II processor commands the I²C master controller to update the `TMDS_Bit_Clock_Ratio` and `Scrambler_Enable` bits of the sink TMDS configuration register to 1. The same I²C master can also transfer the DDC data structure (E-EDID) between the HDMI source and external sink.

4.3.1.14.3. Source Reconfiguration Controller

The Nios II CPU acts as the multirate reconfiguration controller for the HDMI source.

The CPU relies on the periodic rate detection from the Multirate Reconfig Controller (RX) to determine if TX requires reconfiguration. The Avalon-MM slave translator provides the interface between the Nios II processor Avalon-MM master interface and the Avalon-MM slave interfaces of the externally instantiated HDMI source's PLL Reconfig Intel FPGA IP and Transceiver Native PHY (TX).

Figure 12. Nios II Software Flow

The reconfiguration sequence flow for TX is the same as RX, except that the PLL and transceiver reconfiguration, and the reset sequence is performed sequentially. The figure illustrates the Nios II software flow that involves the controls for CVO, I²C master and HDMI source.

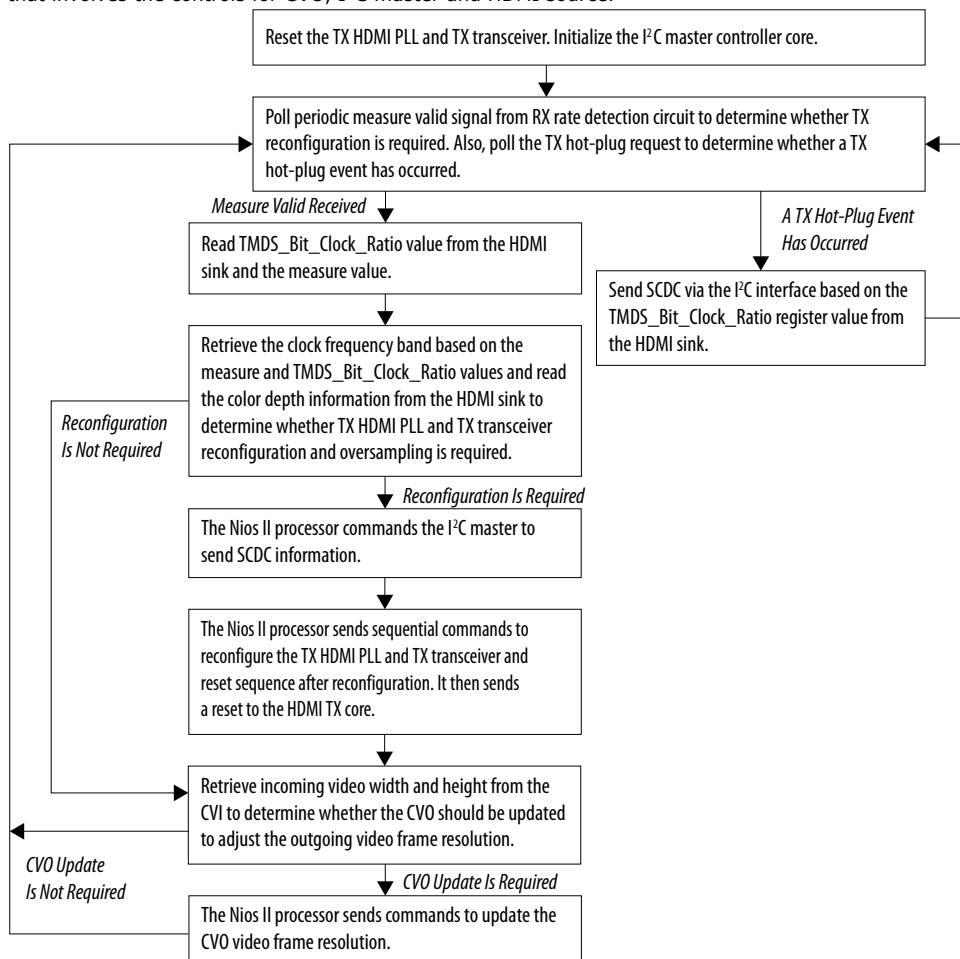

4.3.2. HDMI Hardware Design Requirements

The HDMI design requires an Intel FPGA board and supporting hardware.

- Intel FPGA board
- Bitec HDMI HSMC 2.0 daughter card
- Standard HDMI source—for example, PC with a graphic card and HDMI output
- Standard HDMI sink—for example, monitor with HDMI input
- 2 HDMI cables
 - A cable to connect the graphics card to the Bitec daughter card RX connector.
 - A cable to connect the Bitec daughter card TX connector to the monitor.

Table 19. Intel FPGA Boards and Bitec HDMI HSMC 2.0 Daughter Cards Supported for the Design

| Design Example | Intel FPGA Board | Bitec HDMI HSMC 2.0 Daughter Card |
|-----------------------|-----------------------------------|-----------------------------------|
| Arria V (av_sk) | Arria V GX FPGA Starter Kit | HSMC (Rev8) |
| Arria V (av_sk_hdmi2) | Arria V GX FPGA Starter Kit | HSMC (Rev8) |
| Stratix V (sv_hdmi2) | Stratix V GX FPGA Development Kit | HSMC (Rev8) |

Related Information

- [Arria V GX Starter Kit User Guide](#)
- [Stratix V GX FPGA Development Kit User Guide](#)

4.3.3. Design Walkthrough

Setting up and running the HDMI hardware design consists of four stages.

You can use the Intel-provided scripts to automate these stages.

1. Set up the hardware.
2. Copy the design files to your working directory.
3. Build and compile the design.
4. View the results.

4.3.3.1. Set Up the Hardware

The first stage of the demonstration is to set up the hardware.

To set up the hardware for the demonstration:

1. Connect the Bitec HDMI HSMC 2.0 daughter card to the FPGA development board.
2. Connect the FPGA board to your PC using a USB cable.

Note: The Arria V GX FPGA Starter Kit and Stratix V GX FPGA Development Kit have an On-Board Intel FPGA Download Cable II connector. If your version of the board does not have this connector, you can use an external Intel FPGA Download Cable cable.

3. Connect an HDMI cable from the HDMI RX connector on the Bitec HDMI HSMC 2.0 daughter card to a standard HDMI source, in this case a PC with a graphic card and HDMI output.
4. Connect another HDMI cable from the HDMI TX connector on the Bitec HDMI HSMC 2.0 daughter card to a standard HDMI sink, in this case a monitor with HDMI input.

4.3.3.2. Copy the Design Files

After you set up the hardware, you copy the design files. Copy the hardware demonstration files from one of the following paths to your working directory:

- Arria V
 - 2 symbols per clock (HDMI 1.4b) demonstration: <IP root directory>/altera_hdmi/hw_demo/av_sk
 - 4 symbols per clock (HDMI 2.0b) demonstration: <IP root directory>/altera_hdmi/hw_demo/av_sk_hdmi2
- Stratix V
 - 2 symbols per clock (HDMI 2.0b) demonstration: <IP root directory>/altera_hdmi/hw_demo/sv_hdmi2

4.3.3.3. Build and Compile the Design

After you copy the design files, you can build the design.

You can use the provided Tcl script to build and compile the FPGA design.

1. Open a Nios II Command Shell.
2. Change the directory to your working directory.
3. Type the command and enter `source runall.tcl`.
This script executes the following commands:
 - Generate IP catalog files
 - Generate the Platform Designer system
 - Create an Intel Quartus Prime project
 - Create a software work space and build the software
 - Compile the Intel Quartus Prime project
 - Run Analysis & Synthesis to generate a post-map netlist for DDR assignments
—for VIP passthrough design only
 - Perform a full compilation

Note: If you are a Linux user, you will get a message `cygpath: command not found`. You can safely ignore this message; the script will proceed to generate the next commands.

4.3.3.4. View the Results

At the end of the demonstration, you will be able to view the results on the standard HDMI sink (monitor).

To view the results of the demonstration, follow these steps:

1. Power up the Intel FPGA board.
2. Type the following command on the Nios II Command Shell to download the Software Object File (`.sof`) to the FPGA.

```
nios2-configure-sof output_files/<Quartus project name>.sof
```
3. Power up the standard HDMI source and sink (if you haven't done so).
The design displays the output of your video source (PC).

Note: If the output does not appear, press `cpu_resetn` to reinitialize the system or perform HPD by unplugging the cable from the standard source and plug it back again.

- Open the graphic card control utility (if you are using a PC as source). Using the control panel, you can switch between various video resolutions.

The `av_hdmi2` and `sv_hdmi2` demonstration designs allow any video resolutions up to 4Kp60. The `av_sk` design allows `640x480p60`, `720x480p60`, `1280x720p60`, `1920x1080p60`, and `3840x2160p24` when you select the VIP passthrough mode (`user_dipsw[0] = 0`). If you select the VIP bypass mode (`user_dipsw[0] = 1`), the design allows any video resolutions up to 4Kp60.

4.3.3.4.1. Push Buttons, DIP Switches and LED Functions

Use the push buttons, DIP switches, and LED functions on the board to control your demonstration.

Table 20. Push Buttons, DIP Switches and LEDs Functions

| Push Button/ DIP Switch/LED | Pins | | Functions |
|--------------------------------|-------------------|----------|--|
| | av_sk/av_sk_hdmi2 | sv_hdmi2 | |
| <code>cpu_resetn</code> | D5 | AM34 | Press once to perform system reset. |
| <code>user_pb[0]</code> | A14 | A7 | Press once to turn on and turn off HPD signal to the standard HDMI source. |
| <code>user_pb[1]</code> | B15 | B7 | Press and hold to instruct the TX to send DVI encoded signal and release to send HDMI encoded signal. |
| <code>user_pb[2]</code> | B14 | C7 | Press and hold to instruct the TX to stop sending InfoFrames and release to resume sending. |
| <code>user_dipsw[0]</code> | D15 | Unused | Only used in <code>av_sk</code> design which demonstrates the VIP passthrough feature. <ul style="list-style-type: none"> 0: VIP passthrough 1: VIP bypass |
| <code>user_led[0]</code> | F17 | J11 | RX HDMI PLL lock status. <ul style="list-style-type: none"> 0: Unlocked 1: Locked |
| <code>user_led[1]</code> | G15 | U10 | RX transceiver ready status. <ul style="list-style-type: none"> 0: Not ready 1: Ready |
| <code>user_led[2]</code> | G16 | U9 | RX HDMI core lock status <ul style="list-style-type: none"> 0: At least 1 channel unlocked 1: All 3 channels locked |
| <code>user_led[3]</code> | G17 | AU24 | RX oversampling status. <ul style="list-style-type: none"> 0: Non-oversampled (more than 611 Mbps for <code>av_sk</code> and <code>sv_hdmi2</code>, more than 1,000 Mbps for <code>av_sk_hdmi2</code>) 1: Oversampled (less than 611 Mbps for <code>av_sk</code> and <code>sv_hdmi2</code>, less than 1,000 Mbps for <code>av_sk_hdmi2</code>) |
| <code>user_led[4]</code> | D16 | AF28 | TX HDMI PLL lock status. |

continued...

| Push Button/ DIP Switch/LED | Pins | | Functions |
|--------------------------------|-------------------|----------|--|
| | av_sk/av_sk_hdmi2 | sv_hdmi2 | |
| | | | <ul style="list-style-type: none"> 0: Unlocked 1: Locked |
| user_led[5] | C13 | AE29 | TX transceiver ready status. <ul style="list-style-type: none"> 0: Not ready 1: Ready |
| user_led[6] | C14 | AR7 | TX transceiver PLL lock status. <ul style="list-style-type: none"> 0: Unlocked 1: Locked |
| user_led[7] | C16 | AV10 | TX oversampling status. <ul style="list-style-type: none"> 0: Non-oversampled (more than 611 Mbps for av_sk and sv_hdmi2, more than 1,000 Mbps for av_sk_hdmi2) 1: Oversampled (less than 611 Mbps for av_sk and sv_hdmi2, less than 1,000 Mbps for av_sk_hdmi2) |

5. HDMI Source

5.1. Source Functional Description

The HDMI source core provides direct connection to the Transceiver Native PHY through a 20-bit or 40-bit parallel data path. The clock domains for the auxiliary and audio ports, and the internal modules are different for Support FRL = 1 and Support FRL = 0.

Figure 13. HDMI Source Signal Flow Diagram for TMDS (Support FRL = 0) Design

The figure below shows the flow of the HDMI source signals. The figure shows the various clocking domains used within the core.

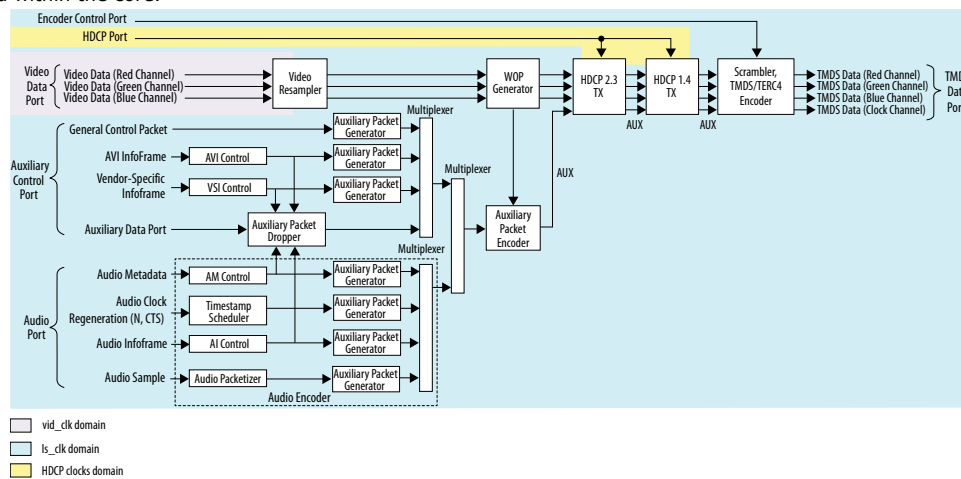

The source core provides four 20-bit parallel data paths corresponding to the 3 color channels and the clock channel.

The source core accepts video, audio, and auxiliary channel data streams. The core produces a scrambled and TMDS/TERC4 encoded data stream that would typically connect to the high-speed transceiver parallel data inputs.

Note: The scrambled data only applies for HDMI 2.0b stream with TMDS Bit Rate higher than 3.4 Gbps.

Central to the core is the Scrambler, TMDS/TERC4 Encoder. The encoder processes either video or auxiliary data.

Figure 14. HDMI Source Signal Flow Diagram for Support FRL = 1 Design

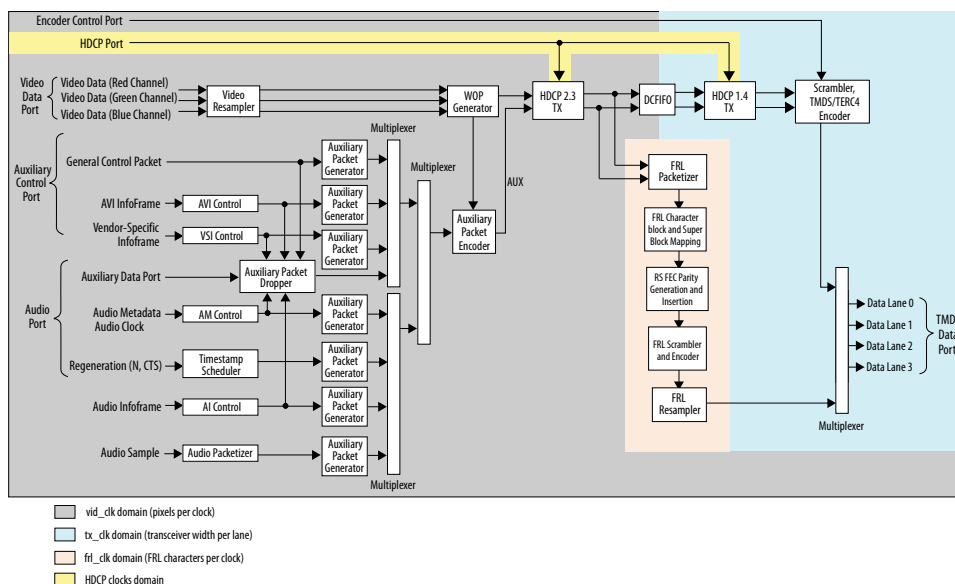

For FRL path design, the video resampler and WOP generator operating at video clock domain accept video data running in the video clock (`vid_clk`) domain. The auxiliary data port, audio data port, and the auxiliary sideband signals also run in the video clock domain.

- A DCFIFO clocks the HDMI data stream from the WOP generator in the video clock domain to the scrambler, TMDS/TERC4 encoder in the transceiver recovered clock (`tx_clk`) domain to create a TMDS data stream.
- The HDMI data stream is also fed into the FRL path in FRL clock (`frl_clk`) domain to create an FRL data stream.

The multiplexer selects either TMDS data stream or FRL data stream as output data for lanes 0–3 based on the FRL rate.

- If FRL rate is 0, the multiplexer selects TMDS data streams as output.
- If FRL rate is non-zero, the multiplexer selects FRL data streams as output.

5.1.1. Source Scrambler, TMDS/TERC4 Encoder

The TMDS/TERC4 encoder implements 8-bit to 10-bit and 4-bit to 10-bit algorithms as defined in the *HDMI 1.4b Specification Section 5.4*. Each data channel, with exception of the clock channel, has its own encoder. You can configure the core to enable scrambling, as defined in the *HDMI 2.0b Specification Section 6.1.2*, before TMDS/TERC4 encoding.

The encoder processes symbol data at 1, 2, or 4 symbols per clock. When the encoder operates in 2 or 4 symbols per clock, it also produces the output in the form of two or four encoded symbols per clock.

The TMDS/TERC4 encoder also produces digital visual interface (DVI) signaling when you deassert the `mode` input signal. DVI signaling is identical to HDMI signaling, except for the absence of data and video islands and TERC4 auxiliary data.

5.1.2. Source Video Resampler

The video resampler consists of a dual-clock FIFO (DCFIFO) and a gearbox.

The gearbox converts data of 8, 10, 12, or 16 bits per component to 8-bit per component data based on the current color depth. The General Control Packet (GCP) conveys the color depth information.

Figure 15. Source Video Resampler Signal Flow Diagram

The figure below shows the components of the video resampler and the signal flow between these components.

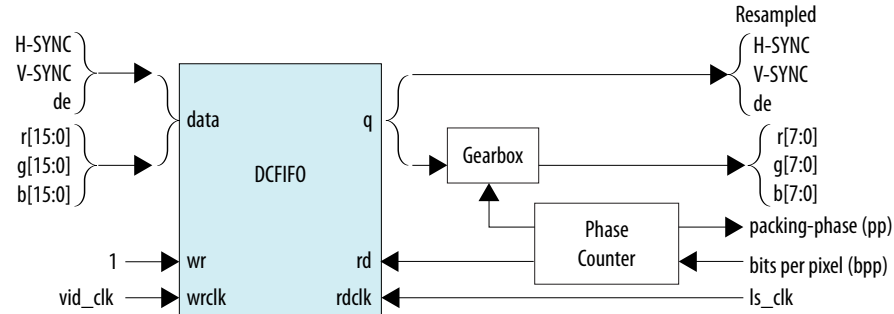

The resampler adheres to the recommended phase encoding method described in *HDMI 1.4b Specification Section 6.5*.

- The phase counter must register the last pixel packing-phase (pp) of the last pixel of the last active line.
- The core then transmits the pp value to the attached sink device in the GCP for packing synchronization.

The HDMI cable may send across four different pixel encodings: RGB 4:4:4, YCbCr 4:4:4, and YCbCr 4:2:2 (as described in *HDMI 1.4b Specification Section 6.5*), and YCbCr 4:2:0 (as described in *HDMI 2.0b Specification Section 7.1*).

Figure 16. Pixel Data Input Format RGB/YCbCr 4:4:4

The figure below shows the RGB/YCbCr 4:4:4 color space pixel bit-field mappings per symbol. When the actual color depth is below 16 bpc, the unused LSBs are set to zero.

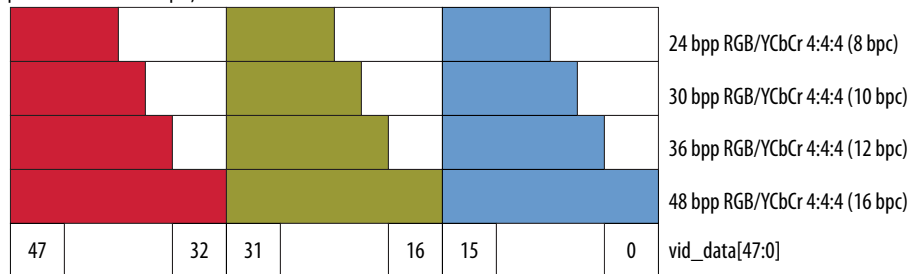
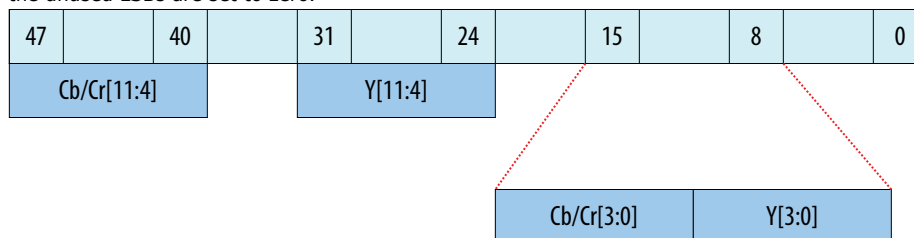

Figure 17. Pixel Data Input Format YCbCr 4:2:2 (12 bpc)

The figure below shows the YCbCr 4:2:2 color space pixel bit-field mappings per symbol. As with 4:4:4 color space, the unused LSBs are set to zero.



The higher order 8 bits of the Y samples are mapped to the 8 bits of Channel 1 and the lower order 4 bits are mapped to the lower order 4 bits of Channel 0.

The first pixel transmitted within a Video Data Period contains three components, Y0, Cb0 and Cr0. The Y0 and Cb0 components are transmitted during the first pixel period while Cr0 is transmitted during the second pixel period. This second pixel period also contains the only component for the second pixel, Y1. In this way, the link carries one Cb sample for every two pixels and one Cr sample for every two pixels. These two components (Cb and Cr) are multiplexed onto the same signal paths on the link.

Figure 18. Pixel Data Input Format YCbCr 4:2:0

The figure shows the YCbCr 4:2:0 color space pixel bit-field mappings. As with 4:4:4 color space, the unused LSBs are set to zero.

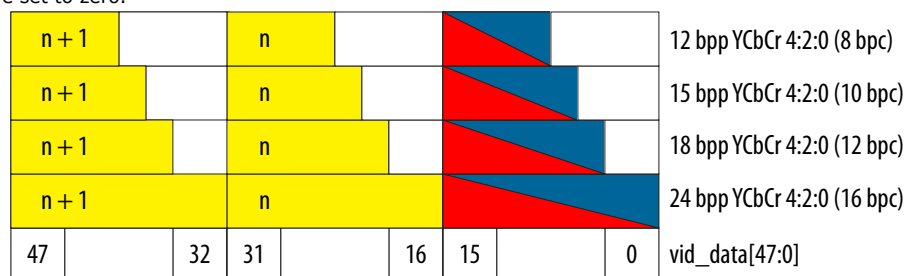

n = Pixel Index

The two horizontally successive 8-bit Y components are transmitted in TMDs Channels 1 and 2, in that order. The 8-bit Cb or Cr components are transmitted alternately in TMDs Channel 0, line by line.

For even lines starting with line 0:

- `vid_data[47:32]` always transfer the Y_{n+1} component
- `vid_data[31:16]` always transfer the Y_n component
- `vid_data[15:0]` always transfer the Cb_n component

For odd lines:

- `vid_data[47:32]` always transfer the Y_{n+1} component
- `vid_data[31:16]` always transfer the Y_n component
- `vid_data[15:0]` always transfer the Cr_n component

The frequency of `vid_clk` must be halved when YCbCr 4:2:0 is used, because two pixels are fed into a single clock cycle.

Figure 19. YCbCr 4:2:0 Transport Using 1 Symbol Per Clock Mode

The figure below shows the YCbCr 4:2:0 transmission when the core operates in 1 symbol per clock mode.

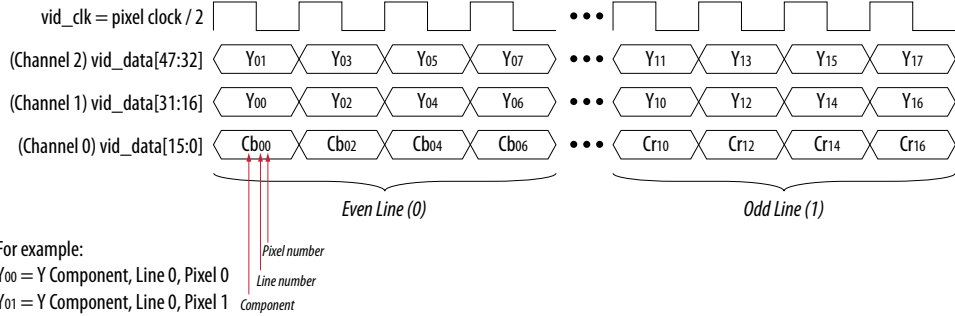

5.1.3. Source Window of Opportunity Generator

The source Window of Opportunity (WOP) generator creates valid data islands within the blanking regions.

During horizontal blanking region, the WOP generator creates a leading region to hold at least 12 period symbols that include eight preamble symbols. The generator also creates a trailing region to hold two data island trailing guard band symbols, at least 12 control period symbols that include eight preamble symbols and two video leading guard band symbols.

During vertical blanking region, the source cannot send more than 18 auxiliary packets consecutively. The WOP generator deasserts the data island output enable (`aux_wop`) line after every 18th auxiliary packet for 32-symbol clocks.

The WOP generator also has an integral number of auxiliary packet cycles: 24 clocks when processing in 1-symbol mode, 16 clocks when processing in 2-symbol mode, and 8 clocks when processing in 4-symbol mode.

Figure 20. Typical Window of Opportunity

The figure below shows a typical output from the WOP generator.

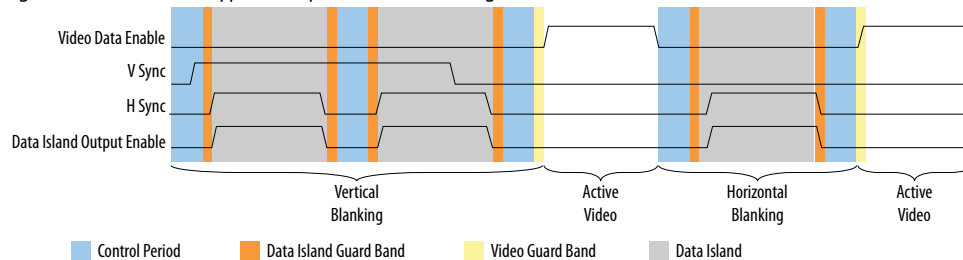

5.1.4. Source Auxiliary Packet Encoder

Auxiliary packets are encoded by the source auxiliary packet encoder.

The auxiliary packets originate from several sources, which are multiplexed into the auxiliary packet encoder in a round-robin schedule. The auxiliary packet encoder converts a standard stream into the channel data format required by the TERC4 encoder.

The auxiliary packet encoder also calculates and inserts the Bose-Chaudhuri-Hocquenghem (BCH) error correction code.

Figure 21. Auxiliary Packet Encoder Input

The figure below shows the auxiliary packet encoder input from a 72-bit input data.

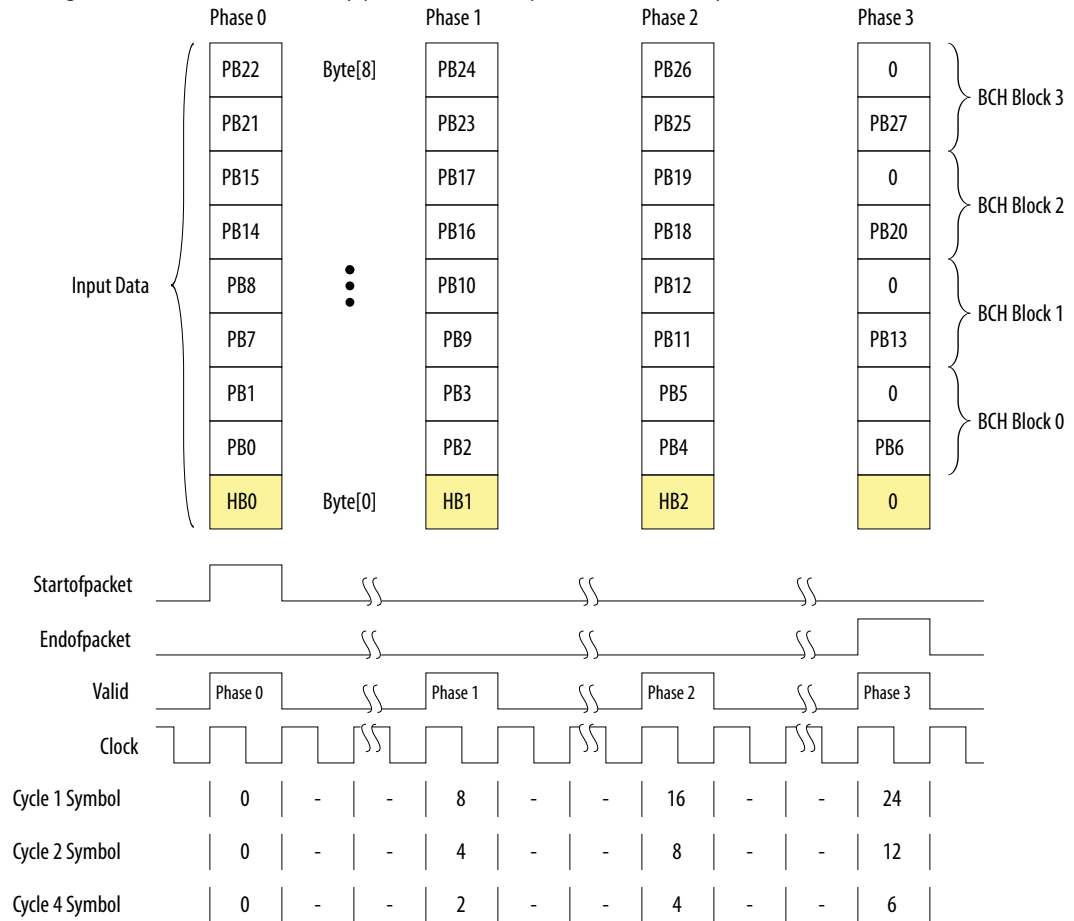

The encoder assumes the data valid input will remain asserted for the duration of a packet to complete. A packet is always 24 clocks (in 1-symbol mode), 12 clocks (in 2-symbol mode), or 6 clocks (in 4-symbol mode).

Figure 22. Typical Auxiliary Packet Stream During Blanking Interval

The figure below shows a typical auxiliary packet stream in 1-symbol per clock mode, where 0 denotes a null packet.

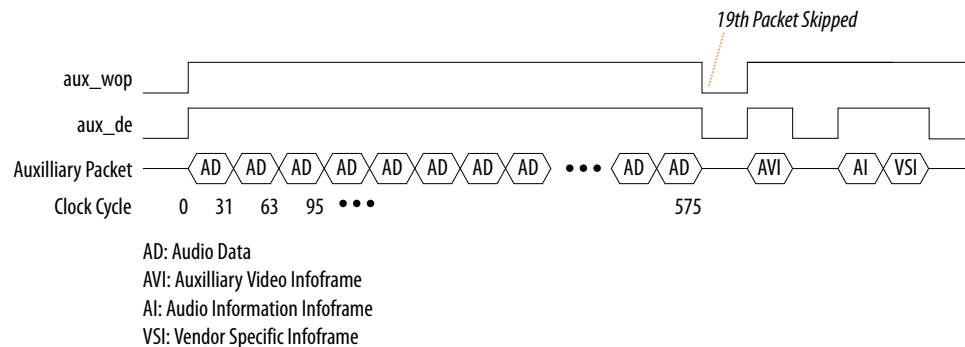

5.1.5. Source Auxiliary Packet Generators

The source core uses various auxiliary packet generators. The packet generators convert the packet field inputs to the auxiliary packet stream format.

The packet generator propagates backpressure from the output ready signal to the input ready signal. The generator asserts the input valid signal when a packet is ready to be transmitted. The input valid signal remains asserted until the end of the packet and the generator receives a ready acknowledgment.

5.1.6. Source Auxiliary Data Path Multiplexers

The auxiliary data path multiplexers provide paths for the various auxiliary packet generators.

The various auxiliary packet generators traverse a multiplexed routing path to the auxiliary packet encoder. The multiplexers obey a round-robin schedule and propagate backpressure.

5.1.7. Source Auxiliary Control Port

To simplify the user logic, the source core has control ports to send the most common auxiliary control packets.

These packets are: General Control Packet, Auxiliary Video Information (AVI) InfoFrame, and HDMI Vendor Specific InfoFrame (VSI).

The core sends the default values in the auxiliary packets. The default values allow the core to send video data compatible with the *HDMI 1.4b Specification* with minimum description.

You can also override the generators using the customized input values. The override values replace the default values when the input checksum is non-zero.

Table 21. Insertion and Filtration

| Auxiliary Packets | | Insertion/Filtration | Frequency of Insertion |
|---|---|--|-----------------------------|
| General Control Packet (GCP) | - | The core always inserts GCP packets from the GCP sideband upon the rising edge of <code>vsync</code> . The core always removes the GCP in the Auxiliary Data Port. You must provide the pixel packing and color depth information through the <code>gcp</code> port. | Once per frame. |
| Auxiliary Video Information (AVI) InfoFrame | <code>info_avi[112]=1'b0</code> | The core inserts <code>info_avi</code> when there is a non-zero bit upon the rising edge of <code>vsync</code> . The core send default values when all bits are zero. The core filters the AVI InfoFrame packet on the Auxiliary Data Port. | Once per frame. |
| | Support FRL=0: <code>info_avi[112]=1'b1</code> Support FRL =1: <code>info_avi[122]=1'b1</code> | The core does not insert <code>info_avi</code> . The AVI InfoFrame packet on the Auxiliary Data Port passes through. | |
| Vendor Specific InfoFrame (VSI) | <code>info_vsi[61]=1'b0</code> | The core inserts <code>info_vsi[60:0]</code> when there is a non-zero bit upon the rising edge of <code>vsync</code> . The core sends default values when all bits are zero. The core filters the VSI InfoFrame packet on the Auxiliary Data Port. | Once per frame. |
| | <code>info_vsi[61]=1'b1</code> | The core does not insert <code>info_vsi[60:0]</code> . The VSI InfoFrame packet on the Auxiliary Data Port passes through. | |
| Audio Metadata (AM) | <code>audio_metadata[165]=1'b0</code> | The core inserts <code>audio_metadata[164:0]</code> when <code>audio_format[3:0]</code> is 3D audio or MST audio upon the rising edge of <code>vsync</code> . The core filters the AM packet on the Auxiliary Data Port. | Once per frame. |
| | <code>audio_metadata[165]=1'b1</code> | The core does not insert <code>audio_metadata[164:0]</code> . The AM packet on the Auxiliary Data Port passes through. | |
| Audio InfoFrame (AI) | <code>audio_info_ai[48]=1'b0</code> | The core inserts <code>audio_info_ai[47:0]</code> when there is a non-zero bit upon the rising edge of <code>vsync</code> . The core sends default values when all bits are zero. The core filters the AI packet on the Auxiliary Data Port. | Once per frame. |
| | <code>audio_info_ai[48]=1'b1</code> | The core does not insert <code>audio_info_ai[47:0]</code> . The AI packet on the Auxiliary Data Port passes through. | |
| Audio Control Regeneration (ACR) | - | The core always inserts the <code>audio_N</code> and <code>audio_CTS</code> . The core does not filter the ACR packet in the auxiliary. If there is ACR packet in the Auxiliary Data Port, you must remove it before passing into the Auxiliary Data Port. | Every 1 ms. |
| Audio Sample | - | The core always inserts <code>audio_data</code> . | Based on audio sample rate. |

continued...

| Auxiliary Packets | | Insertion/Filtration | Frequency of Insertion |
|-------------------|--|--|------------------------|
| | | The core does not filter the audio sample packet in the Auxiliary Data Port. If there is audio sample packet in the Auxiliary Data Port, you must remove it before passing into the Auxiliary Data Port. | |

5.1.7.1. Source General Control Packet (GCP)

Table 22. Source GCP Bit-Fields

This table lists the controllable bit-fields for the Source `gcp[5:0]` port.

| Bit Field | Name | Value | | | | Comment |
|-----------|------------------|---|-----|-----|-----|----------------------------------|
| gcp[3:0] | Color Depth (CD) | CD3 | CD2 | CD1 | CD0 | Color depth |
| | | 0 | 0 | 0 | 0 | Color depth not indicated |
| | | 0 | 1 | 0 | 0 | 8 bpc or 24 bits per pixel (bpp) |
| | | 0 | 1 | 0 | 1 | 10 bpc or 30 bpp |
| | | 0 | 1 | 1 | 0 | 12 bpc or 36 bpp |
| | | 0 | 1 | 1 | 1 | 16 bpc or 48 bpp |
| | | Others | | | | Reserved |
| gcp[4] | Set_AVMUTE | Refer to <i>HDMI 1.4b Specification Section 5.3.6</i> . | | | | |
| gcp[5] | Clear_AVMUTE | Refer to <i>HDMI 1.4b Specification Section 5.3.6</i> . | | | | |

All other fields for the source GCP, (for example, Pixel Packing Phase and Default Phase as described in *HDMI 1.4b Specification Section 5.3.6*) are calculated automatically inside the core. You must provide the bit-field values in the table above through the source `gcp[5:0]` port. The GCP on the Auxiliary Data Port will always be filtered.

5.1.7.2. Source Auxiliary Video Information (AVI) InfoFrame Bit-Fields

Table 23. Source Auxiliary Video Information (AVI) InfoFrame for Support FRL = 0 Designs

The signal bundle is clocked by `ls_clk` for **Support FRL = 0** designs.

| Bit-field | Name | Description | Default Value |
|---------------------|----------|----------------------------|---------------|
| 7:0 | Checksum | Checksum | 8'h67 |
| 9:8 | S | Scan information | 2'h0 |
| 11:10 | B | Bar info data valid | 2'h0 |
| 12 | A0 | Active information present | 1'h0 |
| 14:13 | Y | RGB or YCbCr indicator | 2'h0 |
| 15 | Reserved | Returns 0 | 1'h0 |
| 19:16 | R | Active format aspect ratio | 4'h8 |
| <i>continued...</i> | | | |

| Bit-field | Name | Description | Default Value |
|-----------|----------|---|---------------|
| 21:20 | M | Picture aspect ratio | 2'h0 |
| 23:22 | C | Colorimetry (for example: ITU BT.601, BT.709) | 2'h0 |
| 25:24 | SC | Non-uniform picture scaling | 2'h0 |
| 27:26 | Q | Quantization range | 2'h0 |
| 30:28 | EC | Extended colorimetry | 3'h0 |
| 31 | ITC | IT content | 1'h0 |
| 38:32 | VIC | Video format identification code | 7'h00 |
| 39 | Reserved | Returns 0 | 1'h0 |
| 43:40 | PR | Picture repetition factor | 4'h0 |
| 45:44 | CN | Content type | 2'h0 |
| 47:46 | YQ | YCC quantization range | 2'h0 |
| 63:48 | ETB | Line number of end of top bar | 16'h0000 |
| 79:64 | SBB | Line number of start of bottom bar | 16'h0000 |
| 95:80 | ELB | Pixel number of end of left bar | 16'h0000 |
| 111:96 | SRB | Pixel number of start of right bar | 16'h0000 |
| 112 | Control | <p>Disables the core from inserting the InfoFrame packet.</p> <ul style="list-style-type: none"> 1: The core does not insert <code>info_avi[111:0]</code>. The AVI InfoFrame packet on the Auxiliary Data Port passes through. 0: The core inserts <code>info_avi[111:0]</code> when there is a non-zero bit. The core sends default values when all bits are zero. The core filters the AVI InfoFrame packet on the Auxiliary Data Port. | - |

By default, the HDMI source sets the AVI version to version 2. If the value of `info_avi[30:28]` (EC2, EC1, EC0) is 3'b111, then the HDMI source sets the AVI version to version 4. If the value of `info_avi[39]` is 1'b1 (VIC >= 128) or `info_avi[15]` (Y2) is set to 1, the HDMI source sets the AVI version to version 3.

Table 24. Source Auxiliary Video Information (AVI) InfoFrame for Support FRL = 1 Designs

This signal bundle is clocked by `vid_clk` for **Support FRL = 1** designs.

| Bit-field | Name | Description | Default Value |
|---------------------|----------|----------------------------|---------------|
| 7:0 | Checksum | Checksum | 8'h67 |
| 9:8 | S | Scan information | 2'h0 |
| 11:10 | B | Bar info data valid | 2'h0 |
| 12 | A0 | Active information present | 1'h0 |
| 15:13 | Y | RGB or YCbCr indicator | 3'h0 |
| 19:16 | R | Active format aspect ratio | 4'h8 |
| 21:20 | M | Picture aspect ratio | 2'h0 |
| <i>continued...</i> | | | |

| Bit-field | Name | Description | Default Value |
|-----------|-----------|--|---------------|
| 23:22 | C | Colorimetry (for example: ITU BT.601, BT.709) | 2'h0 |
| 25:24 | SC | Non-uniform picture scaling | 2'h0 |
| 27:26 | Q | Quantization range | 2'h0 |
| 30:28 | EC | Extended colorimetry | 3'h0 |
| 31 | ITC | IT content | 1'h0 |
| 39:32 | VIC | Video format identification code | 8'h00 |
| 43:40 | PR | Picture repetition factor | 4'h0 |
| 45:44 | CN | Content type | 2'h0 |
| 47:46 | YQ | YCC quantization range | 2'h0 |
| 63:48 | ETB | Line number of end of top bar | 16'h0000 |
| 79:64 | SBB | Line number of start of bottom bar | 16'h0000 |
| 95:80 | ELB | Pixel number of end of left bar | 16'h0000 |
| 111:96 | SRB | Pixel number of start of right bar | 16'h0000 |
| 115:112 | F143-F140 | Future use 14 | 4'h0 |
| 119:116 | ACE3-ACE0 | Additional colorimetry extension | 4'h0 |
| 121:120 | - | Reserved | - |
| 122 | Control | Disables the core from inserting the InfoFrame packet. <ul style="list-style-type: none"> 1: The core does not insert <code>info_avi[120:0]</code>. The AVI InfoFrame packet on the Auxiliary Data Port passes through. 0: The core inserts <code>info_avi[120:0]</code> when there is a non-zero bit. The core sends default values when all bits are zero. The core filters the AVI InfoFrame packet on the Auxiliary Data Port. | 2'h0 |

5.1.7.3. Source HDMI Vendor Specific InfoFrame (VSI)

Table 25. Source HDMI Vendor Specific InfoFrame Bit-Fields

The table below lists the bit-fields for VSI (as described in *HDMI 1.4b Specification Section 8.2.3*).

The signal bundle is clocked by `1s_clk`.

Note: For the HDMI Forum-VSI InfoFrame (HF-VSIF) transmission, use external VSI by asserting control bit to 1 and send the data through the Auxiliary Data Port.

| Bit-field | Name | Description | Default Value |
|---------------------|----------|--|---------------|
| 4:0 | Length | Length of HDMI VSI payload | 5'h06 |
| 12:5 | Checksum | Checksum | 8'h69 |
| 36:13 | IEEE | 24-bit IEEE registration identifier (0x000C03) | 24'h000C03 |
| 41:37 | Reserved | Reserved (0) | 5'h00 |
| <i>continued...</i> | | | |

| Bit-field | Name | Description | Default Value |
|-----------|--------------------------|---|---------------|
| 44:42 | HDMI_Video_Format | Structure of extended video formats exclusively defined in <i>HDMI 1.4b Specification</i> | 3'h0 |
| 52:45 | HDMI_VIC or 3D_Structure | <ul style="list-style-type: none"> If HDMI_Video_Format = 3'h1, [52:45] = HDMI proprietary video format identification code If HDMI_Video_Format = 3'h2, [52:49] = 3D_Structure and [48:45] = Reserved (0) | 8'h00 |
| 56:53 | Reserved | Reserved (0) | 4'h00 |
| 60:57 | 3D_Ext_Data | 3D extended data | 4'h0 |
| 61 | Control | <p>Disables the core from inserting the InfoFrame packet.</p> <ul style="list-style-type: none"> 1: The core does not insert <code>info_vsi[60:0]</code>. The VSI InfoFrame packet on the Auxiliary Data Port passes through. 0: The core inserts <code>info_vsi[60:0]</code> when there is a non-zero bit. The core sends default values when all bits are zero. The core filters the VSI InfoFrame packet on the Auxiliary Data Port. | - |

5.1.8. Source Audio Encoder

Audio transport allows four packet types:

- Audio Clock Regeneration
- Audio InfoFrame
- Audio Metadata
- Audio Sample

The Audio Clock Regeneration packet contains the CTS and N values.

Note: You need to provide these values as recommended in *HDMI 1.4b Specification, Section 7.2.1 through 7.2.3* and *HDMI 2.0b Specification, Section 9.2.1* for TMDS mode and *HDMI 2.1 Specification, Section 9.2.2* for FRL mode.

The core schedules this packet to be sent every ms. The timestamp scheduler uses the `audio_clk` and `N` value to determine a 1-ms interval. The audio data queues on a DCFIFO. The core also uses the DCFIFO to synchronize its clock to `ls_clk` when you turn off **Support FRL** and synchronized to `vid_clk` when you turn on **Support FRL**. The Audio Packetizer packs the audio data into the Audio Sample packets according to the specified audio format (as described in *HDMI 1.4b Specification Section 5.3.4*). An Audio Sample packet can contain up to 4 audio samples, based on the required audio sample clock. The core sends the Audio Sample packets whenever there is an available slot in the auxiliary packet stream.

The core determines the payload data packet type from the `audio_format[3:0]` signal.

Table 26. Definition of the Supported audio_format[3:0]

| Value | Name | Description |
|--------|-------------------------------------|--|
| 0 | Linear Pulse-Code Modulation (LPCM) | Use packet type 0x02 to transport payload data |
| 4 | 3D Audio (LPCM) | Use packet type 0x0B to transport payload data |
| 6 | Multi-Stream(MST) Audio for LPCM | Use packet type 0x0E to transport payload data |
| Others | - | Reserved |

The 32-bit audio data is packed in IEC-60958 standard. The least significant word is the left channel sample.

Figure 23. Audio Data Packing

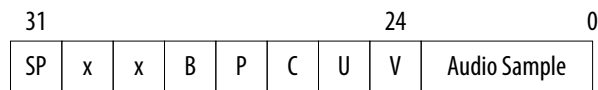

The fields are defined as:

- SP : Sample Present
- x : Not Used
- B : Start of 192-bit IEC-60958 Channel Status
- P : Parity Bit
- C : Channel Status
- U : User Data Bit
- V : Valid Bit

The audio_data port is always at a fixed value of 256 bits. In the LPCM format, the core can send up to 8 channels of audio data.

- Channel 1 audio data should be present at audio_data[31:0].
- Channel 2 audio data should be present at audio_data[63:32] and so on.

The Sample Present (SP) bit determines whether to use 2-channel or 8-channel layout. If one or more SP bit from Channel 2-7 is high, then the core uses the 8-channel layout. Otherwise, the core uses the 2-channel layout. The core ignores all other fields if the SP bit is 0.

The core requires an audio_de port for designs in which the audio_clk port frequency is higher than the actual audio sample clock. The audio_de port qualifies the audio data. If audio_clk is the actual audio sample clock, you can tie the audio_de signal to 1. For audio channels fewer than 8, insert 0 to the respective audio data of the unused audio channels.

The Audio Clock Regeneration and Audio Sample packets on the Auxiliary Data Port are not filtered by the core. You must filter these packets externally if you want to loop back the auxiliary data stream from the sink.

3D Audio Format

In 3D format, the core sends up to 32 channels audio data by consuming up to 4 writes of 8 channels. Assert `audio_format[4]` to indicate the first 8 channels of each sample. For audio channels greater than 8, do not drive `audio_clk` at actual audio sample clock; instead drive `audio_clk` with `ls_clk` and qualify `audio_data` with `audio_de`.

Figure 24. 3D Audio Input Example

Figure below shows the three examples of 3D audio: Full 32 channels, 24 channels, and 12 channels. In the 12 channels example, the 4 most significant audio channels of the last beat are zero.

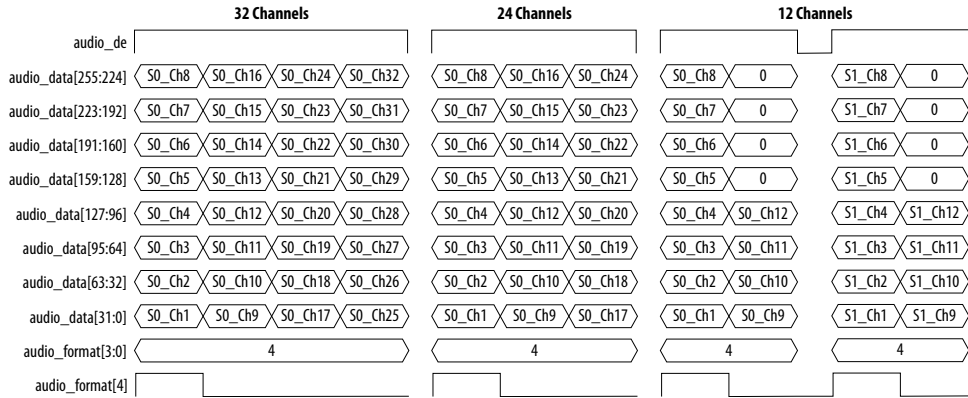

MST Audio Format

In MST format, the core sends 2, 3, or 4 streams of audio. For audio streams fewer than 4, you must set the respective audio data to zero for the unused streams as shown in the figure below.

Figure 25. MST Audio Input Example

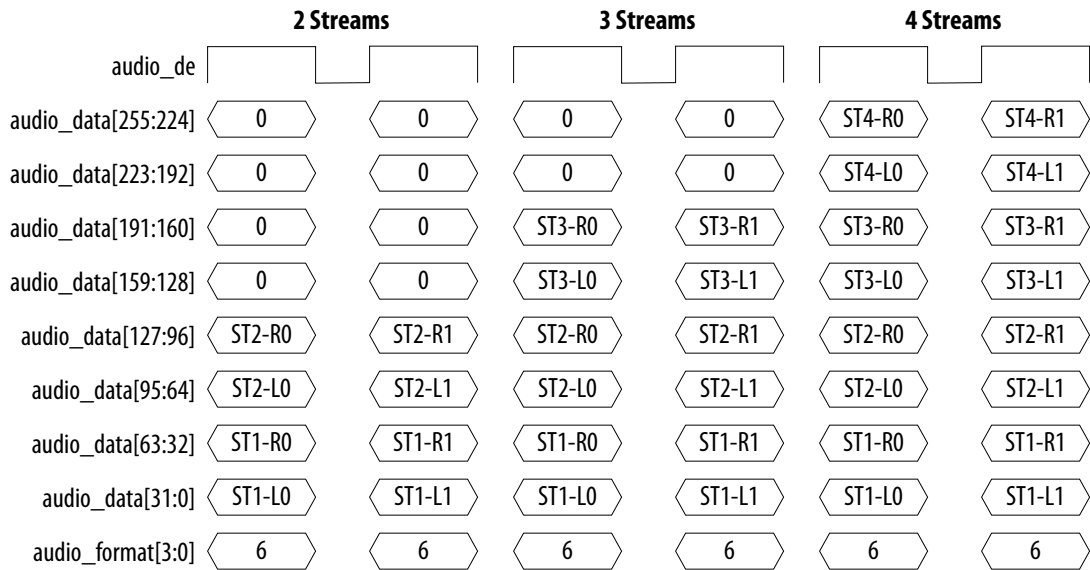

5.1.8.1. Audio InfoFrame (AI) Bundle Bit-Fields

The core sends the AI default values in the auxiliary packets.

The default values are overridden by the customized input values (`audio_info_ai[47:0]`) when the input checksum is non-zero. The core sends the AI packet on the active edge of the `V-SYNC` signal to ensure that the packet is sent once per field.

Table 27. Source Audio InfoFrame Bundle Bit-Fields

Table below lists the AI signal bit-fields (as described in *HDMI 1.4b Specification Section 8.2.2*). The signal bundle is clocked by `ls_clk` for **Support FRL = 0** designs and by `vid_clk` for **Support FRL = 1** designs.

| Bit-field | Name | Description | Default Value |
|-----------|----------|---|---------------|
| 7:0 | Checksum | Checksum | 8'h71 |
| 10:8 | CC | Channel count | 3'h0 |
| 11 | Reserved | Returns 0 | 1'h0 |
| 15:12 | CT | Audio format type | 4'h0 |
| 17:16 | SS | Bits per audio sample | 2'h0 |
| 20:18 | SF | Sampling frequency | 3'h0 |
| 23:21 | Reserved | Returns 0 | 3'h0 |
| 31:24 | CXT | Audio format type of the audio stream | 8'h00 |
| 39:32 | CA | Speaker location allocation FL, FR | 8'h00 |
| 41:40 | LFEPBL | LFE playback level information, dB | 2'h0 |
| 42 | Reserved | Returns 0 | 1'h0 |
| 46:43 | LSV | Level shift information, dB | 4'h0 |
| 47 | DM_INH | Down-mix inhibit flag | 1'h0 |
| 48 | Control | Disables the core from inserting the AI packet. <ul style="list-style-type: none"> 1: The core does not insert <code>audio_info_ai[47:0]</code>. The AI packet on the Auxiliary Data Port passes through. 0: The core inserts <code>audio_info_ai[47:0]</code> when there is a non-zero bit. The core sends default values when all bits are zero. The core filters the AI packet on the Auxiliary Data Port. | - |

5.1.8.2. Audio Metadata Bundle Bit-Fields

The Audio Metadata (AM) packet carries additional information related to 3D Audio and Multi-Stream Audio (MST).

The core sends the AM packet on the active edge of the V-SYNC signal to ensure that the packet is sent once per field. The signal bundle of `audio_metadata[165:0]` is clocked by `ls_clk` for **Support FRL = 0** designs and by `vid_clk` for **Support FRL = 1** designs.

Table 28. Audio Metadata Bundle Bit-Fields for Packet Header and Control

Table below lists the AM signal bit-fields for packet header (as described in the *HDMI 2.0b Specification Section 8.3*) and control.

| Bit-field | Name | Description |
|-----------|---------------|---|
| 0 | 3D_AUDIO | <ul style="list-style-type: none"> 1: Transmits 3D audio 0: Transmits MST audio |
| 2:1 | NUM_VIEWS | Number of views for an MST stream |
| 4:3 | NUM_AUDIO_STR | Number of audio streams - 1 |
| 165 | Control | Disables the core from inserting the AM packet. <ul style="list-style-type: none"> 1: The core does not insert <code>audio_metadata[164:0]</code>. The AM packet on the Auxiliary Data Port passes through. 0: The core inserts <code>audio_metadata[164:0]</code> when <code>audio_format[3:0]</code> is 3D audio or MST audio. The core filters the AM packet on the Auxiliary Data Port. |

Table 29. Audio Metadata Bundle Bit-Fields for Packet Content when 3D_AUDIO = 1

Table below lists the AM signal bit-fields for packet content when `3D_AUDIO = 1` (as described in the *HDMI 2.0b Specification Section 8.3.1*).

| Bit-field | Name | Description |
|-----------|----------|---|
| 9:5 | 3D_CC | Channel count of the transmitted 3D audio |
| 12:10 | Reserved | Reserved (0) |
| 16:13 | ACAT | Audio channel allocation standard |
| 20:17 | Reserved | Reserved (0) |
| 28:21 | 3D_ACAT | Channel/Speaker allocation for 3D audio |
| 164:29 | Reserved | Reserved (0) |

Table 30. Audio Metadata Bundle Bit-Fields for Packet Content when 3D_AUDIO = 0

Table below lists the AM signal bit-fields for packet content when `3D_AUDIO = 0` (as described in the *HDMI 2.0b Specification Section 8.3.2*).

| Bit-field | Name | Description |
|---------------------|-------------------|---|
| 5 | Multiview_Left_0 | Left stereoscopic picture (Subpacket 0 in MST Audio Sample Packet) |
| 6 | Multiview_Right_0 | Right stereoscopic picture (Subpacket 0 in MST Audio Sample Packet) |
| 12:7 | Reserved | Reserved (0) |
| 15:13 | Suppl_A_Type_0 | Supplementary audio type (Subpacket 0 in MST Audio Sample Packet) |
| 16 | Suppl_A_Mixed_0 | Mix of main audio components and a supplementary audio track (Subpacket 0 in MST Audio Sample Packet) |
| <i>continued...</i> | | |

| Bit-field | Name | Description |
|---------------------|-------------------|---|
| 17 | Suppl_A_Valid_0 | Audio stream contains a supplementary audio track (Subpacket 0 in MST Audio Sample Packet) |
| 19:18 | Reserved | Reserved (0) |
| 20 | LC_Valid_0 | Validity of Language_Code (Subpacket 0 in MST Audio Sample Packet) |
| 44:21 | Language_Code_0 | Audio stream language (Subpacket 0 in MST Audio Sample Packet) |
| 45 | Multiview_Left_1 | Left stereoscopic picture (Subpacket 1 in MST Audio Sample Packet) |
| 46 | Multiview_Right_1 | Right stereoscopic picture (Subpacket 1 in MST Audio Sample Packet) |
| 52:47 | Reserved | Reserved (0) |
| 55:53 | Suppl_A_Type_1 | Supplementary audio type (Subpacket 1 in MST Audio Sample Packet) |
| 56 | Suppl_A_Mixed_1 | Mix of main audio components and a supplementary audio track (Subpacket 1 in MST Audio Sample Packet) |
| 57 | Suppl_A_Valid_1 | Audio stream contains a supplementary audio track (Subpacket 1 in MST Audio Sample Packet) |
| 59:58 | Reserved | Reserved (0) |
| 60 | LC_Valid_1 | Validity of Language_Code (Subpacket 1 in MST Audio Sample Packet) |
| 84:61 | Language_Code_1 | Audio stream language (Subpacket 1 in MST Audio Sample Packet) |
| 85 | Multiview_Left_2 | Left stereoscopic picture (Subpacket 2 in MST Audio Sample Packet) |
| 86 | Multiview_Right_2 | Right stereoscopic picture (Subpacket 2 in MST Audio Sample Packet) |
| 92:87 | Reserved | Reserved (0) |
| 95:93 | Suppl_A_Type_2 | Supplementary audio type (Subpacket 2 in MST Audio Sample Packet) |
| 96 | Suppl_A_Mixed_2 | Mix of main audio components and a supplementary audio track (Subpacket 2 in MST Audio Sample Packet) |
| 97 | Suppl_A_Valid_2 | Audio stream contains a supplementary audio track (Subpacket 2 in MST Audio Sample Packet) |
| 99:98 | Reserved | Reserved (0) |
| 100 | LC_Valid_2 | Validity of Language_Code (Subpacket 2 in MST Audio Sample Packet) |
| 124:101 | Language_Code_2 | Audio stream language (Subpacket 2 in MST Audio Sample Packet) |
| 125 | Multiview_Left_3 | Left stereoscopic picture (Subpacket 3 in MST Audio Sample Packet) |
| 126 | Multiview_Right_3 | Right stereoscopic picture (Subpacket 3 in MST Audio Sample Packet) |
| 132:127 | Reserved | Reserved (0) |
| 135:133 | Suppl_A_Type_3 | Supplementary audio type (Subpacket 3 in MST Audio Sample Packet) |
| continued... | | |

| Bit-field | Name | Description |
|-----------|-----------------|---|
| 136 | Suppl_A_Mixed_3 | Mix of main audio components and a supplementary audio track (Subpacket 3 in MST Audio Sample Packet) |
| 137 | Suppl_A_Valid_3 | Audio stream contains a supplementary audio track (Subpacket 3 in MST Audio Sample Packet) |
| 139:138 | Reserved | Reserved (0) |
| 140 | LC_Valid_3 | Validity of Language_Code (Subpacket 3 in MST Audio Sample Packet) |
| 164:141 | Language_Code_3 | Audio stream language (Subpacket 3 in MST Audio Sample Packet) |

5.1.9. HDCP 1.4 TX Architecture

The HDCP 1.4 transmitter block encrypts video and auxiliary data prior to the transmission over serial link that has HDCP 1.4 device connected.

The HDCP 1.4 TX core consists of the following entities:

- Control and Status Registers Layer
- Authentication Layer
- Video Stream and Auxiliary Layer

Figure 26. Architecture Block Diagram of HDCP 1.4 TX IP

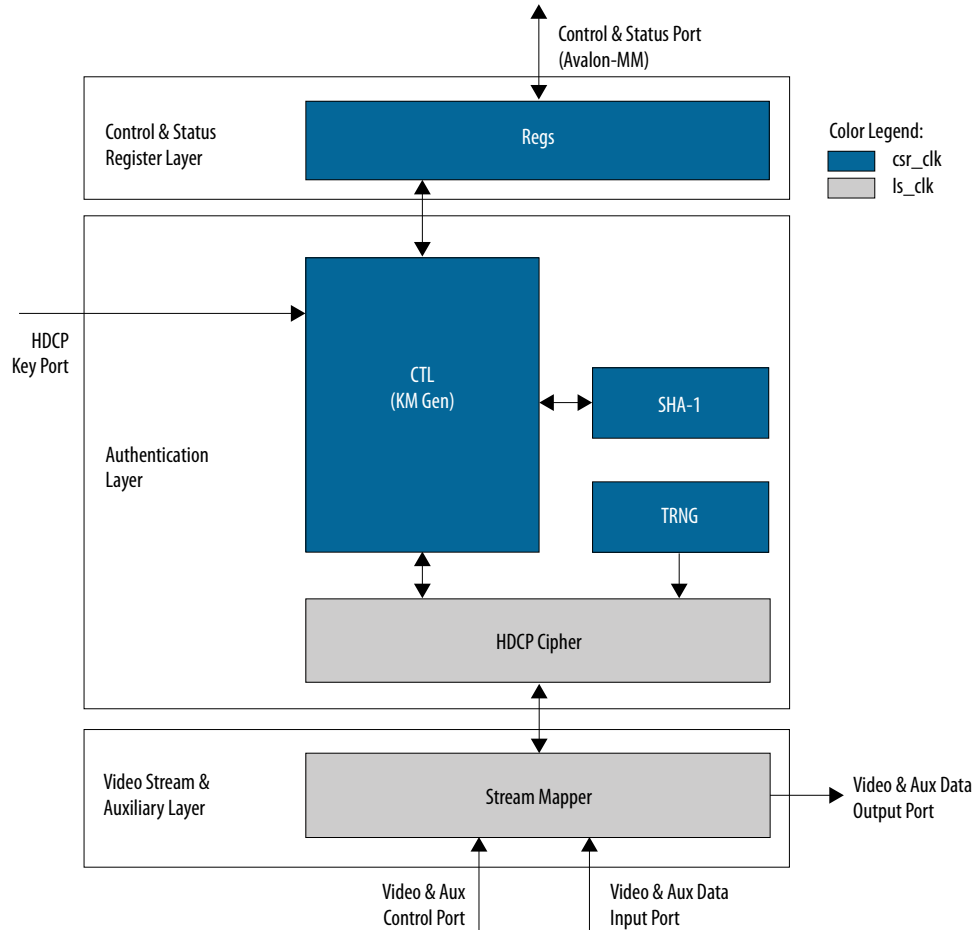

The Nios II processor typically drives the HDCP 1.4 TX core. The processor implements the authentication protocol. The processor accesses the IP through the Control and Status Port using Avalon Memory Mapped (Avalon-MM) interface.

The HDCP specifications requires the HDCP 1.4 TX core to be programmed with the DCP-issued production keys – Device Private Keys (Akeys) and Key Selection Vector (Aksv). The IP retrieves the key from the on-chip memory externally to the core through the HDCP Key Port. The on-chip memory must store the key data in the arrangement in the table below.

Table 31. HDCP 1.4 TX Key Port Addressing

| Address | Content |
|---------------------|---------------------|
| 6'h28 | {16'd0, Aksv[39:0]} |
| 6'h27 | Akeys39[55:0] |
| 6'h26 | Akeys38[55:0] |
| <i>continued...</i> | |

| Address | Content |
|---------|---------------|
| ... | ... |
| 6'h01 | Akeys01[55:0] |
| 6'h00 | Akeys00[55:0] |

When authenticating with the HDCP 1.4 repeater device, the HDCP 1.4 TX core must perform the second part of the authentication protocol. This second part corresponds to the computation of the SHA-1 hash digest for all downstream device KSVs which are written to the registers in Control and Status Register Layer using the Control and Status Port (Avalon-MM).

The Video Stream and Auxiliary layer receives audio and video content over its Video and Aux Data Input Port, and performs the encryption operation. The Video Stream and Auxiliary Layer detects the Encryption Status Signaling (ESS) provided by the HDMI TX core to determine when to encrypt frames.

You can use the HDCP 1.4 registers to customize your design configurations. The HDCP 1.4 TX core supports full handshaking mechanism for authentication. Every issued command should be followed by polling of the assertion of its corresponding status bit before proceeding to issuing the next command. The value of AUTH_CMD must be in one-hot format that only one bit can be set at a time.

Table 32. HDCP 1.4 TX Registers Mapping

| Address | Register | R/W | Reset | Bit | Bit Name | Description |
|---------|--------------------|-----|------------|------|-----------|---|
| 0x00 | AUTH_CMD (one-hot) | WO | 0x00000000 | 31:6 | Reserved | Reserved. |
| | | | | 5 | GO_V | Set to 1 to compute V and compare against V' during authentication with repeater. Self-cleared. |
| | | | | 4 | Reserved | Reserved. |
| | | | | 3 | GEN_RI | Set to 1 to generate and receive R0 during authentication exchange or Ri during link integrity verification. Ri-Ri' comparison should be performed by Nios® II processor. Self-cleared. |
| | | | | 2 | GO_KM | Set to 1 to compute master key (km). Self-cleared. |
| | | | | 1 | GEN_AKSV | Set to 1 to request and receive Aksv. Self-cleared. |
| | | | | 0 | GEN_AN | Set to 1 to generate and receive new true random An. Self-cleared. |
| 0x01 | AUTH_MSGDATAIN | WO | 0x00000000 | 31:8 | Reserved | Reserved. |
| | | | | 7:0 | MSGDATAIN | Write messages (in byte) from receiver in burst mode. 1. Master key computation: Prior to setting GO_KM to 1, the BCAPS.REPEATER bit had |

continued...

| Address | Register | R/W | Reset | Bit | Bit Name | Description |
|---------|-----------------|-----|-----------|------|-----------|--|
| | | | | | | <p>to be set and the following messages had to be written in this sequence:</p> <ol style="list-style-type: none"> a. 5 bytes of Bksv with least significant byte (lsb) first. <p>2. V generation: Prior to setting GO_V to 1, the following messages had to be written in this sequence:</p> <ol style="list-style-type: none"> a. 20 bytes of V' with lsb first b. Variable length of KSV list with lsb first c. 2 bytes of Bstatus with lsb first |
| 0x02 | AUTH_STATUS | RO | 0x0000000 | 31 | KM_OK | Asserted by the core to indicate the received Bksv is valid. Poll KM_DONE until it is set before reading KM_OK. |
| | | | | 30 | V_OK | Asserted by the core to indicate V-V' comparison is passed. Poll V_DONE until it is set before reading V_OK. |
| | | | | 29:6 | Reserved | Reserved. |
| | | | | 5 | V_DONE | Asserted by the core when V is generated. Self-cleared upon next GO_V is set. |
| | | | | 4 | Reserved | Reserved |
| | | | | 3 | RI_DONE | Asserted by the core when Ri is generated. Self-cleared upon next GEN_RI is set. |
| | | | | 2 | KM_DONE | Asserted by the core when Km is generated. Self-cleared upon next GO_KM is set. |
| | | | | 1 | AKSV_DONE | Asserted by the core when Aksv is ready to be read from MSGDATAOUT. Self-cleared upon next GEN_AKSV is set. |
| | | | | 0 | AN_DONE | Asserted by the core when new random An is generated and ready to be read from MSGDATAOUT. Self-cleared upon next GEN_AN is set. |
| 0x03 | AUTH_MSGDATAOUT | RO | 0x0000000 | 31:8 | Reserved | Reserved. |

continued...

| Address | Register | R/W | Reset | Bit | Bit Name | Description |
|---------|----------|-----|------------|------|-------------|--|
| | | | | 7:0 | MSGDATAOUT | Read messages (in byte) from the IP in burst mode. <ol style="list-style-type: none"> 1. An generation: When AN_DONE is set to 1, reading this offset 8 times to obtain An with lsb first. 2. Aksv request: When AKSV_DONE is set to 1, reading this offset 5 times to obtain Aksv with lsb first. 3. Ri request: When RI_DONE is set to 1, reading this offset 2 times to obtain Ri with lsb first. |
| 0x04 | VID_CTL | RW | 0x00000000 | 31:1 | Reserved | Reserved. |
| | | | | 0 | HDCP_ENABLE | Set to 1 to enable HDCP 1.4 encryption. Set to 0 if HDCP 1.4 encryption is not required especially when it is in unauthenticated state. |
| 0x05 | BCAPS | RW | 0x00000000 | 31:2 | Reserved | Reserved. |
| | | | | 1 | REPEATER | Downstream repeater capability. Write bit 6 (REPEATER) of Bcaps received from downstream to this offset. |
| | | | | 0 | Reserved | Reserved. |

5.1.10. HDCP 2.3 TX Architecture

The HDCP 2.3 transmitter block encrypts video and auxiliary data prior to the transmission over serial link that has HDCP 2.3 device connected.

The HDCP 2.3 TX core consists of the following entities:

- Control and Status Registers Layer
- Authentication and Cryptographic Layer
- Video Stream and Auxiliary Layer

Figure 27. Architecture Block Diagram of HDCP 2.3 TX IP

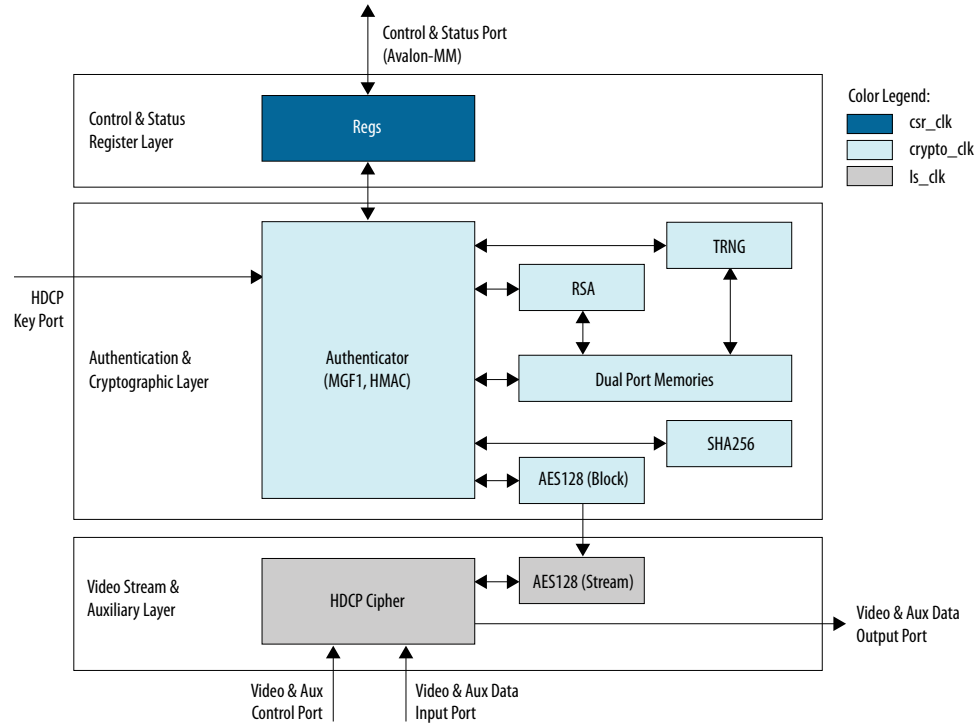

The Nios II processor typically drives the HDCP 2.3 TX core. The processor implements the authentication protocol. The processor accesses the IP through the Control and Status Port using Avalon Memory Mapped (Avalon-MM) interface.

The HDCP specifications requires the HDCP 2.3 TX core to be programmed with the DCP-issued production key – Global Constant (Ic128). The IP retrieves the key from the on-chip memory externally to the core through the HDCP Key Port. The on-chip memory must store the key data in the arrangement in the table below.

Table 33. HDCP 2.3 TX Key Port Addressing

| Address | Content |
|---------|---------------|
| 2'h3 | Ic128[127:96] |
| 2'h2 | Ic128[95:64] |
| 2'h1 | Ic128[63:32] |
| 2'h0 | Ic128[31:0] |

The Video Stream and Auxiliary Layer receives audio and video content over its Video and Aux Data Input port, and performs the encryption operation. The Video Stream and Auxiliary Layer detects the Encryption Status Signaling (ESS) provided by the HDMI TX core to determine when to encrypt frames.

You can use the HDCP 2.3 registers to perform authentication. The HDCP 2.3 TX core supports full handshaking mechanism for authentication. Every issued command should be followed by polling of the assertion of its corresponding status bit before proceeding to issuing the next command. The value of CRYPTO_CMD must be in one-hot encoding format that only one bit can be set at a time.

Table 34. HDCP 2.3 TX Registers Mapping

| Address | Register | R/W | Reset | Bit | Bit Name | Description |
|---------|----------------------|-----|------------|-------|-------------|---|
| 0x00 | CRPYTO_CMD (one-hot) | WO | 0x00000000 | 31:11 | Reserved | Reserved |
| | | | | 10 | GO_HMAC_M | Set to 1 to compute M and verify against M'. Self-cleared upon operation is busy. |
| | | | | 9 | GO_HMAC_V | Set to 1 to compute V and verify against V'. Self-cleared upon operation is busy. |
| | | | | 8 | GEN_RIV | Set to 1 to generate and receive new random riv. Self-cleared upon operation is busy. |
| | | | | 7 | GEN_EDKEYKS | Set to 1 to generate and receive new random Edkey(ks). Self-cleared upon operation is busy. |
| | | | | 6 | GO_HMAC_L | Set to 1 to compute L and verify against L'. Self-cleared upon operation is busy. |
| | | | | 5 | GEN_RN | Set to 1 to generate and receive new random rn. Self-cleared upon operation is busy. |
| | | | | 4 | GO_HMAC_H | Set to 1 to compute H and verify against H'. Self-cleared upon operation is busy. |
| | | | | 3 | GO_KD | Set to 1 to compute kd (dkey0, dkey1). Self-cleared upon operation is busy. |
| | | | | 2 | GEN_EKPUBKM | Set to 1 to generate and receive new random Epub(km). Self-cleared upon operation is busy. |
| | | | | 1 | GO_SIG | Set to 1 to verify signature (certx or SRM). Self-cleared upon operation is busy. |
| | | | | 0 | GEN_RTX | Set to 1 to generate and receive new random rtx. Self-cleared upon operation is busy. |
| 0x01 | CRYPTO_MSGDATAIN | WO | 0x00000000 | 31:8 | Reserved | Reserved |
| | | | | 7:0 | MSGDATAIN | Write messages (in byte) from receiver in burst mode. 1. Signature verification (certx): Prior to setting GO_SIG to 1, the following messages had to be written in this sequence: <i>continued...</i> |

| Address | Register | R/W | Reset | Bit | Bit Name | Description |
|---------|----------|-----|-------|-----|----------|---|
| | | | | | | <ul style="list-style-type: none"> a. 384 bytes of signature with least significant byte (lsb) first b. 5 bytes of Receiver ID with most significant byte (msb) first c. 128 bytes of Receiver Public Key modulus (n) with msb first d. 3 bytes of Receiver Public Key exponent (e) with msb first e. 2 bytes of Reserved with msb first <p>2. Signature verification (SRM): Prior to setting GO_SIG to 1, the following messages had to be written in this sequence:</p> <ul style="list-style-type: none"> a. 384 bytes of signature with lsb first b. All preceding fields of the SRM (except signature) with msb first <p>3. Master Key encryption: Prior to setting GEN_EKPUBKM to 1, the following messages had to be written in this sequence:</p> <ul style="list-style-type: none"> a. 128 bytes of Receiver Public Key modulus (n) with msb first b. 3 bytes of Receiver Public Key exponent (e) with msb first. <p>4. Compute kd for HMAC: Prior to setting GO_KD to 1, the following messages had to be written in this sequence:</p> <ul style="list-style-type: none"> a. 8 bytes of rrx with msb first b. 3 bytes of RxCaps with msb first <p>5. H-H' comparison: Prior to setting GO_HMAC_H to 1, the following messages had to be written in this sequence:</p> <ul style="list-style-type: none"> a. 32 bytes of H' with msb first <p>6. L-L' comparison: Prior to setting GO_HMAC_L to 1, the following messages had to be written in this sequence:</p> <ul style="list-style-type: none"> a. 32 bytes of L' with msb first <p>7. V-V' comparison: Prior to setting GO_HMAC_V to 1, the following messages had to be written in this sequence:</p> |

continued...

| Address | Register | R/W | Reset | Bit | Bit Name | Description |
|---------|---------------|-----|------------|-------|--------------|---|
| | | | | | | <ul style="list-style-type: none"> a. 16 bytes of V' with msb first b. Variable length of ReceiverID_List with msb first c. 2 bytes of RxInfo with msb first d. 3 bytes of seq_num_V with msb first <p>8. M-M' comparison: Prior to setting GO_HMAC_M to 1, the following messages had to be written in this sequence:</p> <ul style="list-style-type: none"> a. 32 bytes of M' with msb first b. 2 bytes of StreamID_Type with msb first c. 3 bytes of seq_num_M with msb first |
| 0x02 | CRYPTO_STATUS | RO | 0x00000000 | 31 | SIG_OK | Asserted by the core to indicate signature verification is passed. Poll SIG_DONE until it is set before reading SIG_OK. |
| | | | | 30 | H_OK | Asserted by the core to indicate H-H' comparison is passed. Poll H_DONE until it is set before reading H_OK. |
| | | | | 29 | L_OK | Asserted by the core to indicate L-L' comparison is passed. Poll L_DONE until it is set before reading L_OK. |
| | | | | 28 | V_OK | Asserted by the core to indicate V-V' comparison is passed. Poll V_DONE until it is set before reading V_OK. |
| | | | | 27 | M_OK | Asserted by the core to indicate M-M' comparison is passed. Poll M_DONE until it is set before reading M_OK. |
| | | | | 26:11 | Reserved | Reserved |
| | | | | 10 | M_DONE | Asserted by the core when M-M' comparison is done. Self-cleared upon next GO_HMAC_M is set. |
| | | | | 9 | V_DONE | Asserted by the core when V-V' comparison is done. Self-cleared upon next GO_HMAC_V is set. |
| | | | | 8 | RIV_DONE | Asserted by the core when riv is generated and ready to be read from MSGDATAOUT. Self-cleared upon next GEN_RIV is set. |
| | | | | 7 | EDKEYKS_DONE | Asserted by the core when Edkey(ks) is generated and ready to be read from MSGDATAOUT. Self-cleared upon next GEN_EDKEYKS is set. |

continued...

| Address | Register | R/W | Reset | Bit | Bit Name | Description |
|---------|-------------------|-----|-----------|------|--------------|--|
| | | | | 6 | L_DONE | Asserted by the core when L-L' comparison is done. Self-cleared upon next GO_HMAC_L is set. |
| | | | | 5 | RN_DONE | Asserted by the core when rn is generated and ready to be read from MSGDATAOUT. Self-cleared upon next GEN_RN is set. |
| | | | | 4 | H_DONE | Asserted by the core when H-H' comparison is done. Self-cleared upon next GO_HMAC_H is set. |
| | | | | 3 | KD_DONE | Asserted by the core when kd is generated. Self-cleared upon next GO_KD is set. |
| | | | | 2 | EKPUBKM_DONE | Asserted by the core when Ekp(km) is generated and ready to be read from MSGDATAOUT. Self-cleared upon next GEN_EKPUBKM is set. |
| | | | | 1 | SIG_DONE | Asserted by the core when signature verification is done. Self-cleared upon next GO_SIG is set. |
| | | | | 0 | RTX_DONE | Asserted by the core when rtx is generated and ready to be read from MSGDATAOUT. Self-cleared upon next GEN_RTX is set. |
| 0x03 | CRYPTO_MSGDATAOUT | RO | 0x0000000 | 31:8 | Reserved | Reserved. |
| | | | | 7:0 | MSGDATAOUT | Read messages (in byte) from IP core in burst mode. <ol style="list-style-type: none"> Rtx generation: When RTX_DONE is set to 1, reading this offset 8 times to obtain rtx with msb first. Master Key generation: When EKPUBKM_DONE is set to 1, reading this offset 128 times to obtain Ekp(km) with msb first. Rn generation: When RN_DONE is set to 1, reading this offset 8 times to obtain rn with msb first. Session Key generation: When EDKEYKS_DONE is set to 1, reading this offset 16 times to obtain Edkey(ks) with msb first. Riv generation: When RIV_DONE is set to 1, reading this offset 8 times to obtain riv with msb first. |
| 0x04 | VID_CTL | RW | 0x0000000 | 31:1 | Reserved | Reserved. |
| | | | | 0 | HDCP_ENABLE | Set to 1 to enable HDCP 2.3 encryption. Set to 0 if HDCP 2.3 encryption is not required especially when it is in unauthenticated state. |

5.1.11. FRL Packetizer

The FRL packetizer separates HDMI data into FRL packets.

Each FRL packet comprises a single map character of 0 to 1022 data characters.

5.1.12. FRL Character Block and Super Block Mapping

An FRL Super Block contains four FRL Character Blocks. FRL Character Blocks transport one or more FRL packets.

Each Character Block contains up to 502 FRL characters transporting FRL packets and eight FRL characters carrying Reed-Solomon parity data.

Each FRL Super Block is preceded by a group of three or four Start Super Blocks (SSB) or a group of three or four Scrambler Reset (SR) characters. SSB and SR characters are comma characters used by a receiver for character alignment.

5.1.13. Reed-Solomon (RS) Forward Error Correction (FEC) Generation and Insertion

FEC protects the FRL stream by using the Reed-Solomon (RS) encoding with an RS (255,251) code over GF (256).

The IP demultiplexes the data on the link into four RS blocks to create the RS parity words. The parity data are interleaved onto the data lanes.

The primitive polynomial used to form the GF (256) field is:

$$p(x) = x^8 + x^4 + x^3 + x^2 + 1$$

The corresponding RS code generator polynomial used by the encoder is:

$$g(x) = x^4 + 15x^3 + 54x^2 + 120x + 64$$

5.1.14. FRL Scrambler and Encoder

The IP scrambles all FRL data, except the SSB and SR special characters, for EMI/RFI reduction.

The IP then encodes the scrambled data into FRL characters using 16B/18B encoding.

5.1.15. Source FRL Resampler

FRL resampler consists of the mixed-width DCFIFO to clock the FRL characters from the `frl_clk` domain to `tx_clk` domain.

In FRL path, the IP processes video data in FRL characters per clock*18 bits. FRL characters per clock are always 16. The mixed-width FIFO converts the data width into (Number of lanes*Effective transceiver width) bits width. For each link rate, the `frl_clk` and `tx_clk` frequency is reconfigured to the specific ratio to keep the throughput of the data the same from `frl_clk` domain to `tx_clk` domain.

5.1.16. TX Oversampler

The TX oversampler transmits data by repeating each bit of the input word a given number of times and constructs the output words.

There are three possible oversampling factors: 3, 4, and 5. The oversampler assumes that the input word is only valid for the number of clock cycles defined by the oversampling factor. The oversampler is enabled when the outgoing data stream is determined to be below the TX transceiver minimum data rate. The oversampler then reads the DCFIFO once every number of clock cycles determined by the oversampling factor.

5.1.17. Clock Enable Generator

The clock enable generator is a logic block that generates a clock enable pulse.

This clock enable pulse asserts every number of clock cycles defined by the oversampling factor and serves as a read request signal to clock the data out from the DCFIFO.

Figure 28. Oversampling Blocks and Clock Enable Blocks When Support FRL = 0

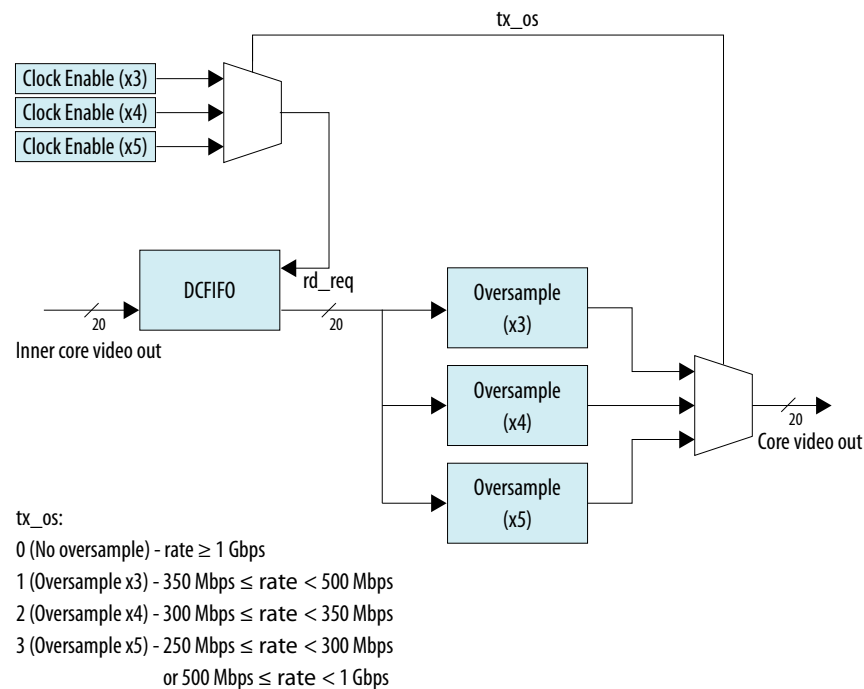
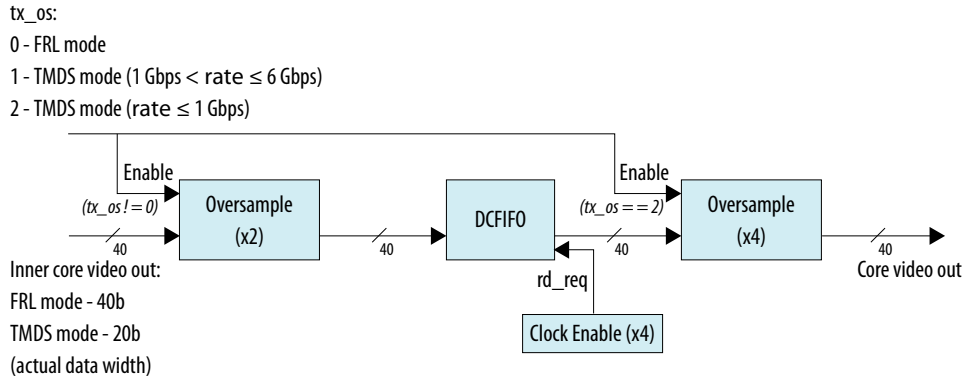

Figure 29. Oversampling Blocks and Clock Enable Block When Support FRL = 1



5.1.18. I²C Master

When you enable the **Include I2C** parameter, the HDMI source includes the Intel FPGA Avalon[®] I²C core in the design.

The HDMI source uses the I²C core to communicate with the SCDC and EDID from the HDMI sink through the DDC signals.

Related Information

[Embedded Peripherals IP User Guide](#)

For more information about the Intel FPGA Avalon I²C core.

5.2. Source Interfaces

The table lists the port interfaces of the source.

Table 35. HDMI Source Interfaces

N is the number of pixels per clock.

| Interface | Port Type | Clock Domain | Port | Direction | Description |
|-----------|-----------|--------------|-----------|-----------|---|
| Reset | Reset | - | reset | Input | Main asynchronous reset input. |
| | Reset | - | reset_vid | Input | Reset input for the video domain. <i>Note:</i> This signal is only available when Support FRL = 0 . |
| Clock | Clock | - | ls_clk | Input | Link speed clock input. The out_c(3), out_r(2), out_g(1), and out_b(0) TMDS encoded data outputs run at this clock frequency. ls_clk frequency = data rate per lane / 20 This signal connects to the transceiver output clock only if TMDS bit rate is |

continued...

| Interface | Port Type | Clock Domain | Port | Direction | Description |
|-----------|-----------|--------------|----------------------|-----------|---|
| | | | | | <p>above the minimum transceiver data rate, which means no oversampling is required.</p> <p>This signal should connect to a PLL output clock that supplies the <code>ls_clk</code> frequency if the TMDS bit rate is below the minimum transceiver data rate, which means oversampling is required.</p> <p>In TMDS mode, data rate per lane is a function of pixel frequency and color depth ratio.</p> <p>Data rate per lane = Pixel frequency x 10 x Color depth ratio.</p> <ul style="list-style-type: none"> 8 bpc: Color depth ratio = 1 10 bpc: Color depth ratio = 1.25 12 bpc: Color depth ratio = 1.5 16 bpc: Color depth ratio = 2 <p><i>Note:</i> This port is not available when the SUPPORT_FRL parameter is enabled.</p> |
| | Clock | - | <code>vid_clk</code> | Input | <p>Video data clock input. When Support FRL = 0, <code>vid_clk</code> frequency = data rate per lane/transceiver width/color depth ratio.</p> <ul style="list-style-type: none"> For RGB and YCbCr 4:4:4/4:2:2 transport: <code>vid_clk</code> frequency = (data rate per lane/transceiver width)/color depth ratio. For YCbCr 4:2:0 transport: <code>vid_clk</code> frequency = ((data rate per lane/transceiver width)/color depth ratio)/2. <code>vid_clk</code> needs to be synchronous to <code>ls_clk</code>. |

continued...

| Interface | Port Type | Clock Domain | Port | Direction | Description |
|-----------|-----------|--------------|------------------------|-----------|--|
| | | | | | <p>When Support FRL = 1, <code>vid_clk</code> frequency can be a fixed clock frequency. Intel recommends to use 225 MHz for the <code>vid_clk</code>.</p> <ul style="list-style-type: none"> <code>vid_clk</code> runs at the maximum frequency across all resolutions and FRL rates. The video data is qualified by the <code>vid_valid</code> signal. <code>vid_clk</code> can be asynchronous to <code>ls_clk</code> and <code>frl_clk</code>. <p>Refer to Table 39 on page 89 for more details.</p> |
| | Clock | - | <code>tx_clk</code> | Input | Transceiver recovered clock. Connect this signal to the output clock of the TX transceiver output clock. |
| | Clock | - | <code>frl_clk</code> | Input | <p>Clock supplied to the FRL path.</p> <p>FRL clock frequency = (data rate * number of lanes) / (FRL characters per clock * 18).</p> <p><code>frl_clk</code> needs to be synchronous to <code>tx_clk</code>.</p> <p><i>Note:</i> The number of lanes is always 4. For FRL rates 3, 4, 5, and 6, all 4 FRL lanes are used to transmit data. For FRL rates 1 and 2, only 3 FRL lanes are used to transmit data, and the 4th lane is unused.</p> <p>In Intel Arria 10 devices, FRL characters per clock is 16.</p> <p>In Intel Stratix 10 devices, FRL characters per clock is 8.</p> |
| | Clock | - | <code>audio_clk</code> | Input | <p>Audio clock input. Connect this signal to <code>ls_clk</code> when Support FRL = 0 or to <code>vid_clk</code> when Support FRL = 1 by qualifying the slower frequency of <code>audio_data</code> with <code>audio_de</code>.</p> <p>If you connect this signal to a clock at actual audio sample frequency, you must tie <code>audio_de</code> to 1.</p> |

continued...

| Interface | Port Type | Clock Domain | Port | Direction | Description |
|-----------------|-----------|----------------------|---------------------------------|-----------|---|
| | | | | | For audio channels greater than 8, do not drive <code>audio_clk</code> at actual audio sample clock; instead drive <code>audio_clk</code> with <code>ls_clk</code> when Support FRL = 0 or to <code>vid_clk</code> when Support FRL = 1, and qualify <code>audio_data</code> with <code>audio_de</code> . <i>Note:</i> Applicable only when you turn on the Support auxiliary and Support audio parameters. |
| | Clock | - | <code>mgmt_clk</code> | Input | Free-running system clock input (100 MHz). This clock connects to the I ² C master and HPD debouncing logic. <i>Note:</i> This signal is not available if you turn off the Include I2C parameter. |
| Video Data Port | Conduit | <code>vid_clk</code> | <code>vid_data[N*48-1:0]</code> | Input | Video 48-bit pixel data input port. For <i>N</i> pixels per clock, this port accepts <i>N</i> 48-bit pixels per clock. |
| | Conduit | <code>vid_clk</code> | <code>vid_de[N-1:0]</code> | Input | Video data enable input that indicates active picture region. |
| | Conduit | <code>vid_clk</code> | <code>vid_hsync[N-1:0]</code> | Input | Video horizontal sync input. |
| | Conduit | <code>vid_clk</code> | <code>vid_vsync[N-1:0]</code> | Input | Video vertical sync input. |
| | Conduit | <code>vid_clk</code> | <code>vid_ready</code> | Output | Indicates if the TX core is ready to process new data. When <code>vid_ready</code> is asserted, the TX core is ready to process new data. <i>Note:</i> This signal is only available when Support FRL = 1. <code>vid_ready</code> is always high for 8 bits per component (BPC). This signal toggles for different color depths. <ul style="list-style-type: none"> For 10 bpc, <code>vid_ready</code> is high for 4 out of 5 clock cycles. For 12 bpc, <code>vid_ready</code> is high for 2 out of 3 clock cycles. For 16 bpc, <code>vid_ready</code> is high for 1 out of 2 clock cycles. Refer to Source Deep Color Implementation When Support FRL = 1 on page 93 for more details. |

continued...

| Interface | Port Type | Clock Domain | Port | Direction | Description |
|--------------------|-----------|---|------------------------------|-----------|---|
| | Conduit | vid_clk | vid_valid | Input | <p>Indicates if the video data is valid. When vid_clk is running at the actual pixel clock, this signal should always be asserted.</p> <p><i>Note:</i> This signal is only available when Support FRL = 1.</p> <p>When you generate the video data at a frequency higher than the actual pixel clock, use vid_valid to qualify the validity of the video data. vid_valid and vid_clk guarantee the exact pixel clock rate.</p> <p>Refer to Valid Video Data on page 90 for more details.</p> |
| | Conduit | vid_clk | vid_overflow | Output | <p>Indicates if the FIFO clocking the data from the video path to the FRL path is overflowing.</p> <p>Under normal operation, this signal is not expected to assert.</p> <p>Reset HDMI TX core if this signal is asserted.</p> <p>Applicable only for FRL mode.</p> |
| TMDS/FRL Data Port | Conduit | Support FRL=1: tx_clk Support FRL =0: ls_clk | out_b[transceiver width-1:0] | Output | <p>When in TMDS mode, this signal is TMDS encoded blue channel (0) output.</p> <p>When in FRL mode, this signal is FRL lane 0.</p> <ul style="list-style-type: none"> When Support FRL = 0, transceiver width is configured to 20 bits. When Support FRL = 1, transceiver width is configured to 40 bits. <p><i>Note:</i> For TMDS mode, only the 20 bits from the least significant bits are used. For FRL mode, all 40 bits are used.</p> |
| | Conduit | Support FRL=1: tx_clk Support FRL =0: ls_clk | out_g[transceiver width-1:0] | Output | <p>When in TMDS mode, this signal is TMDS encoded green channel (1) output.</p> <p>When in FRL mode, this signal is FRL lane 1.</p> <ul style="list-style-type: none"> When Support FRL = 0, transceiver width is configured to 20 bits. When Support FRL = 1, transceiver width is configured to 40 bits. |

continued...

| Interface | Port Type | Clock Domain | Port | Direction | Description |
|----------------------|-----------|---|------------------------------|-----------|---|
| | | | | | <i>Note:</i> For TMDS mode, only the 20 bits from the least significant bits are used. For FRL mode, all 40 bits are used. |
| | Conduit | Support FRL=1: tx_clk Support FRL =0: ls_clk | out_r[transceiver width-1:0] | Output | When in TMDS mode, this signal is TMDS encoded red channel (2) output. When in FRL mode, this signal is FRL lane 2. <ul style="list-style-type: none"> When Support FRL = 0, transceiver width is configured to 20 bits. When Support FRL = 1, transceiver width is configured to 40 bits. <i>Note:</i> For TMDS mode, only the 20 bits from the least significant bits are used. For FRL mode, all 40 bits are used. |
| | Conduit | Support FRL=1: tx_clk Support FRL =0: ls_clk | out_c[transceiver width-1:0] | Output | When in TMDS mode, this signal is TMDS encoded clock channel (3) output. When in FRL mode, this signal is FRL lane 3. <ul style="list-style-type: none"> When Support FRL = 0, transceiver width is configured to 20 bits. When Support FRL = 1, transceiver width is configured to 40 bits. <i>Note:</i> For TMDS mode, only the 20 bits from the least significant bits are used. For FRL mode, all 40 bits are used. |
| | Conduit | - | in_lock | Input | When asserted, the HDMI TX core begins to operate. Synchronize this signal to the same clock domain as reset port. When Support FRL =0, in_lock, reset and reset_vid should run at same clock domain. |
| Encoder Control Port | Conduit | Support FRL=1: tx_clk Support FRL =0: ls_clk | mode | Input | Encoding mode input. <ul style="list-style-type: none"> 0: DVI 1: HDMI |

continued...

| Interface | Port Type | Clock Domain | Port | Direction | Description |
|----------------------------|-----------|---|----------------------|-----------|--|
| | Conduit | Support FRL=1: tx_clk Support FRL =0: ls_clk | tmds_bit_clock_ratio | Input | Indicates if TMDS Bit Rate is greater than 3.4 Gbps in TMDS mode. <ul style="list-style-type: none"> 0: (TMDS Bit Rate) / (TMDS Clock Rate) ratio is 10 1 = (TMDS Bit Rate) / (TMDS Clock Rate) ratio is 40 |
| | Conduit | Support FRL=1: tx_clk Support FRL =0: ls_clk | scrambler_enable | Input | Enables scrambling. <ul style="list-style-type: none"> 0: Instructs the source device not to perform scrambling 1: Instructs the source device to perform scrambling |
| | Conduit | Support FRL=1: tx_clk Support FRL =0: ls_clk | ctrl[N*6-1:0] | Input | DVI control side-band inputs to override the necessary control and synchronization data in the green and red channels. |
| | | Bit-Field | n=0,1.....N-1 | | |
| | | n*6+5 | CTL3 | | |
| | | n*6+4 | CTL2 | | |
| | | n*6+3 | CTL1 | | |
| | n*6+2 | CTL0 | | | |
| | n*6+1 | Reserved (0) | | | |
| | n*6 | Reserved (0) | | | |
| Link Training Control Port | Conduit | frl_clk | scdc_frl_start | Input | <ul style="list-style-type: none"> When set to 1, the TX core transmits normal video data. When set to 0, the TX core transmits link training pattern data. |
| | Conduit | frl_clk | scdc_frl_rate[3:0] | Input | Specifies the FRL rate (link rate and number of lanes) that the TX core is running. <ul style="list-style-type: none"> 0: Disable FRL 1: Fixed rate link at 3 Gbps per lane on 3 lanes 2: Fixed rate link at 6 Gbps per lane on 3 lanes 3: Fixed rate link at 6 Gbps per lane on 4 lanes 4: Fixed rate link at 8 Gbps per lane on 4 lanes 5: Fixed rate link at 10 Gbps per lane on 4 lanes 6: Fixed rate link at 12 Gbps per lane on 4 lanes |
| continued... | | | | | |

| Interface | Port Type | Clock Domain | Port | Direction | Description |
|--|-----------|--------------|--|-----------|---|
| | Conduit | frl_clk | scdc_frl_pattern[15:0] | Input | Indicates the link training pattern that each lane on the TX core is transmitting . <ul style="list-style-type: none"> • scdc_frl_pattern[3:0]: Link training pattern for lane 0 • scdc_frl_pattern[7:4]: Link training pattern for lane 1 • scdc_frl_pattern[11:8]: Link training pattern for lane 2 • scdc_frl_pattern[15:12]: Link training pattern for lane 3 • 4'd0: No link training pattern • 4'd1: All 1's pattern • 4'd2: All 0's pattern • 4'd3: Nyquist clock pattern • 4'd4: TxFFE Compliance Test Pattern • 4'd5: LFSR 0 • 4'd6: LFSR 1 • 4'd7: LFSR 2 • 4'd8: LFSR 3 |
| Auxiliary Data Port (Applicable only when you enable Support auxiliary parameter) ⁽⁷⁾ | Conduit | aux_clk | aux_ready | Output | Auxiliary data channel ready output. Asserted high to indicate that the core is ready to accept data. |
| | Conduit | aux_clk | aux_valid | Input | Auxiliary data channel valid input to qualify the data. |
| | Conduit | aux_clk | aux_data[71:0] | Input | Auxiliary data channel data input. For information about the bit-fields, refer to Figure 21 on page 47. |
| | Conduit | aux_clk | aux_sop | Input | Auxiliary data channel start-of-packet input to mark the beginning of a packet. |
| | Conduit | aux_clk | aux_eop | Input | Auxiliary data channel end-of-packet input to mark the end of a packet. |
| Auxiliary Control Port (Applicable only when you enable Support auxiliary parameter) ⁽⁷⁾ | Conduit | aux_clk | gcp[5:0] | Input | General Control Packet user input. For information about the bit-fields, refer to Table 22 on page 50. |
| | Conduit | aux_clk | info_avi[122:0] (Support FRL = 1) | Input | Auxiliary Video Information InfoFrame user input. |

continued...

⁽⁷⁾ aux_clk = ls_clk (**Support FRL = 0**)
aux_clk = vid_clk (**Support FRL = 1**)

| Interface | Port Type | Clock Domain | Port | Direction | Description | | | | |
|---|-------------|--------------|--|-----------|--|-----------|-------------|---------------------|--|
| | | | info_avi[112:0] (Support FRL = 0) | | For information about the bit-fields, refer to Table 23 on page 50. | | | | |
| | Conduit | aux_clk | info_vsi[61:0] | Input | Vendor Specific Information InfoFrame user input. For information about the bit-fields, refer to Table 25 on page 52. | | | | |
| Audio Port (Applicable only when you enable Support auxiliary and Support audio parameters) ⁽⁷⁾ | Conduit | audio_clk | audio_CTS[19:0] | Input | Audio CTS value input. | | | | |
| | Conduit | audio_clk | audio_N[19:0] | Input | Audio N value input. | | | | |
| | Conduit | audio_clk | audio_data[255:0] | Input | Audio data input. For audio channel values, refer to Table 38 on page 84. | | | | |
| | Conduit | audio_clk | audio_de | Input | Audio data valid input. | | | | |
| | Conduit | audio_clk | audio_mute | Input | Audio mute input. No audio will be transmitted when this signal is asserted high. | | | | |
| | Conduit | aux_clk | audio_info_ai[48:0] | Input | Audio InfoFrame user input. <i>Note:</i> If you provide <code>audio_info_ai[48:0]</code> using <code>audio_clk</code> with actual audio sample frequency, you must synchronize the clock domain to <code>ls_clk</code> externally. For information about the bit-fields, refer to Table 27 on page 56. | | | | |
| | Conduit | aux_clk | audio_metadata[165:0] | Input | Carries additional information related to 3D audio and MST audio. <i>Note:</i> If you provide <code>audio_metadata[165:0]</code> using <code>audio_clk</code> with actual audio sample frequency, you must synchronize the clock domain to <code>ls_clk</code> externally. For information about the bit-fields, refer to Table 28 on page 57, Table 29 on page 57, and Table 30 on page 57. | | | | |
| | Conduit | audio_clk | audio_format[4:0] | Input | Controls the transmission of the 3D audio and indicates the audio format to be transmitted. | | | | |
| | | | | | <table border="1"> <thead> <tr> <th>Bit-Field</th> <th>Description</th> </tr> </thead> <tbody> <tr> <td colspan="2" style="text-align: right;"><i>continued...</i></td> </tr> </tbody> </table> | Bit-Field | Description | <i>continued...</i> | |
| Bit-Field | Description | | | | | | | | |
| <i>continued...</i> | | | | | | | | | |

| Interface | Port Type | Clock Domain | Port | Direction | Description | | | | |
|----------------------------|---|---|------------|-----------|--|---|--|-----|---|
| | | | | | <table border="1"> <tr> <td>4</td> <td>Assert to indicate the first 8 channels of each 3D audio sample.</td> </tr> <tr> <td>3:0</td> <td>For information about the bit-fields, refer to Table 26 on page 54.</td> </tr> </table> | 4 | Assert to indicate the first 8 channels of each 3D audio sample. | 3:0 | For information about the bit-fields, refer to Table 26 on page 54. |
| 4 | Assert to indicate the first 8 channels of each 3D audio sample. | | | | | | | | |
| 3:0 | For information about the bit-fields, refer to Table 26 on page 54. | | | | | | | | |
| PHY Interface Control Port | Conduit | Support FRL=1: tx_clk Support FRL =0: ls_clk | os[1:0] | Input | Oversampling control signal to control the oversampling factor. Support FRL = 1 <ul style="list-style-type: none"> 0: No oversample. Send this when you are transmitting FRL. 1: 2x oversampling: Send this when you are transmitting TMDS rate between 1 Gb/s < rate ≤ 6 Gb/s 2: 8x oversampling: Send this when you are transmitting TMDS rate ≤ 1 Gb/s Support FRL = 0 <ul style="list-style-type: none"> 0: No oversample. Send this when you are transmitting TMDS rate ≥ 1 Gb/s. 1: 3x oversampling: Send this when you are transmitting data rate between 350 Mb/s ≤ rate < 500 Gb/s 2: 4x oversampling: Send this when you are transmitting data rate between 300 Mb/s ≤ rate < 350 Gb/s 3: 5x oversampling: Send this when you are transmitting data rate between 250 Mb/s ≤ rate < 300 Gb/s or data rate between 500 Mb/s ≤ rate < 1 Gb/s | | | | |
| Hot Plug Detect | Conduit | - | tx_hpd | Input | Detects the Hot Plug Detect (HPD) status. This signal should be driven with the same signal to the HPD pin on the HDMI connector. | | | | |
| | | mgmt_clk | tx_hpd_req | Output | The core asserts the tx_hpd_req signal if the tx_hpd signal holds for more than 100 milliseconds, indicating a valid HPD. The | | | | |

continued...

| Interface | Port Type | Clock Domain | Port | Direction | Description |
|---|-----------|--------------|----------------------------|-----------|---|
| | | | | | tx_hpd_req signal deasserts if the tx_hpd signal is not detected. |
| I ² C Master Interface Port | Conduit | - | i2c_scl | Inout | The SCL signal from the I ² C bus on the HDMI connector. <i>Note:</i> This signal is not available if you turn off the Include I2C parameter. |
| | Conduit | - | i2c_sda | Inout | The SDA signal from the I ² C bus on the HDMI connector. <i>Note:</i> This signal is not available if you turn off the Include I2C parameter. |
| | Avalon MM | mgmt_clk | i2c_master_address[3:0] | Input | The Avalon memory-mapped interface signals to the I ² C master. Connect these signals to an Avalon memory-mapped master such as the Nios processor to perform read and write operations to the EDID block. <i>Note:</i> These signals are not available if you turn off the Include I2C parameter. |
| | Avalon MM | mgmt_clk | i2c_master_write | Input | |
| | Avalon MM | mgmt_clk | i2c_master_read | Input | |
| | Avalon MM | mgmt_clk | i2c_master_writedata[31:0] | Input | |
| | Avalon MM | mgmt_clk | i2c_master_readdata[31:0] | Output | |
| | | | | | |
| | | | | | |
| HDCP Port (Applicable only when you enable Support HDCP 2.3 or Support HDCP 1.4 parameters) | Reset | - | hdcp_reset | Input | Main asynchronous reset. |
| | Clock | - | csr_clk | Input | HDCP clock for control and status registers. Typically, shares the Nios II processor clock (100 MHz). |
| | | - | crypto_clk | Input | HDCP 2.3 clock for authentication and cryptographic layer. You can use any clock with a frequency of up to 200 MHz. Not applicable for HDCP 1.4. <i>Note:</i> The clock frequency determines the authentication latency. |
| | Avalon-MM | csr_clk | csr_addr[7:0] | Input | The Avalon-MM slave port that provides access to internal control and status register, mainly for authentication messages transfer. This interface is expected to operate at Nios II processor clock domain. Because of the extremely large bit portion of message, the IP transfers |
| | | | csr_wr | Input | |
| | | | csr_rd | Input | |
| | | | csr_wrddata[31:0] | Input | |
| csr_rddata[31:0] | Output | | | | |

continued...

| Interface | Port Type | Clock Domain | Port | Direction | Description |
|--|---------------|-------------------------|-----------|--|--|
| | | | | | <p>the message in burst mode with full handshaking mechanism.</p> <p>Write transfers always have a wait time of 0 cycle while read transfers have a wait time of 1 cycle.</p> <p>The addressing should be accessed as word addressing in the Platform Designer flow. For example, addressing of 4 in the Nios II software selects the address of 1 in the slave.</p> |
| | Conduit (Key) | crypto_clk | kmem_wait | Input | Always keep this signal asserted until the key is ready to be read. This signal is not available if you turn on the Support HDCP Key Management parameter. |
| kmem_rdaddr[3:0] (HDCP 2.3) kmem_rdaddr[9:4] (HDCP 1.4) | | | Output | Key read address bus. [3:2] = Reserved. This signal is not available if you turn on the Support HDCP Key Management parameter. | |
| kmem_q[31:0] (HDCP 2.3) kmem_q[87:32] (HDCP 1.4) | | | Input | 32-bit (HDCP 2.3) or 56-bit (HDCP 1.4) data for read transfers. Read transfer always have a wait time of 1 cycle. This signal is not available if you turn on the Support HDCP Key Management parameter. | |
| Avalon-MM | csr_clock | hdcp1_kmem_wr | Input | <p>The Avalon memory-mapped slave port provides write access to internal HDCP 1.4 key storage.</p> <p>Write transfers always have a wait time of 0</p> <p>The Avalon memory-mapped master access the addressing as word addressing in the Platform Designer flow.</p> <p>For example, addressing of 4 in the Avalon memory-mapped master selects the address of 1 in the slave.</p> <p>These signals are only available if you turn on the Support HDCP Key Management parameter and the Support HDCP 1.4 parameter.</p> | |
| | | hdcp1_kmem_wrdata[31:0] | Input | | |
| | | hdcp1_kmem_addr[6:0] | Input | | |
| Avalon-MM | csr_clk | hdcp2_kmem_wr | Input | <p>The Avalon memory-mapped slave port provides write access to internal HDCP 2.3 key storage.</p> | |
| | | hdcp2_kmem_wrdata[31:0] | Input | | |

continued...

| Interface | Port Type | Clock Domain | Port | Direction | Description |
|-----------|-----------|--------------|----------------------|-----------|--|
| | | | hdcp2_kmem_addr[3:0] | Input | Write transfers always have a wait time of 0 The Avalon memory-mapped master access the addressing as word addressing in the Platform Designer flow. For example, addressing of 4 in the Avalon memory-mapped master selects the address of 1 in the slave. These signals are only available if you turn on the Support HDCP Key Management parameter and the Support HDCP 2.3 parameter. |
| | Conduit | ls_clk | hdcp1_enabled | Output | This signal is asserted by the IP if the outgoing video and auxiliary data are HDCP 1.4 encrypted. |
| | | | hdcp2_enabled | Output | This signal is asserted by the IP if the outgoing video and auxiliary data are HDCP 2.3 encrypted. |
| | csr_clk | | hdcp1_disable | Input | Assert this signal to disable the HDCP 1.4 IP. <i>Note:</i> You must reset the HDCP IP (hdcp_reset) after toggling this signal. You must not call the software API hdcp_main() while this signal is asserted. You must call the software API hdcp_unauth() after deasserting this signal. |
| | | | hdcp2_disable | Input | Assert this signal to disable the HDCP 2.3 IP. <i>Note:</i> You must reset the HDCP IP (hdcp_reset) after toggling this signal. You must not call the software API hdcp_main() while this signal is asserted. You must call the software API hdcp_unauth() after deasserting this signal. |

Table 36. out_c Value for TMDS Bit Rate Less than 3.4 Gbps

TMDS_Bit_clock_Ratio = 0 and out_c value is constant.

| N | out_c Value |
|---|---|
| 1 | 10'b1111100000 |
| 2 | 20'b1111100000_1111100000 |
| 4 | 40'b1111100000_1111100000_1111100000_1111100000 |

Table 37. out_c Value for TMDS Bit Rate Greater than 3.4 Gbps in TMDS Mode

TMDS_Bit_clock_Ratio = 1 and out_c value is repeated indefinitely.

| N | out_c Value | | | |
|---|-----------------|-----------------|-----------------|-----------------|
| | t | t+1 | t+2 | t+3 |
| 1 | 10'h000 | 10'h000 | 10'h3ff | 10'h3ff |
| 2 | 20'h00000 | 20'hfffff | 20'h00000 | 20'hfffff |
| 4 | 40'hfffff 00000 | 40'hfffff 00000 | 40'hfffff 00000 | 40'hfffff 00000 |

Table 38. Audio Channels

| Bit-Field | Audio Channel | |
|-----------|--------------------------|------------------------|
| | LPCM and 3D Audio (LPCM) | MST Audio (LPCM) |
| 255:224 | 8 or 16 or 24 or 32 | Stream 4 right channel |
| 223:192 | 7 or 15 or 23 or 31 | Stream 4 left channel |
| 191:160 | 6 or 14 or 22 or 30 | Stream 3 right channel |
| 159:128 | 5 or 13 or 21 or 29 | Stream 3 left channel |
| 127:96 | 4 or 12 or 20 or 28 | Stream 2 right channel |
| 95:64 | 3 or 11 or 19 or 27 | Stream 2 left channel |
| 63:32 | 2 or 10 or 18 or 26 | Stream 1 right channel |
| 31:0 | 1 or 9 or 17 or 25 | Stream 1 left channel |

5.3. Source Clock Tree

The source uses various clocks.

Figure 30. Source Clock Tree

The figure shows how the different clocks connect in the source core.

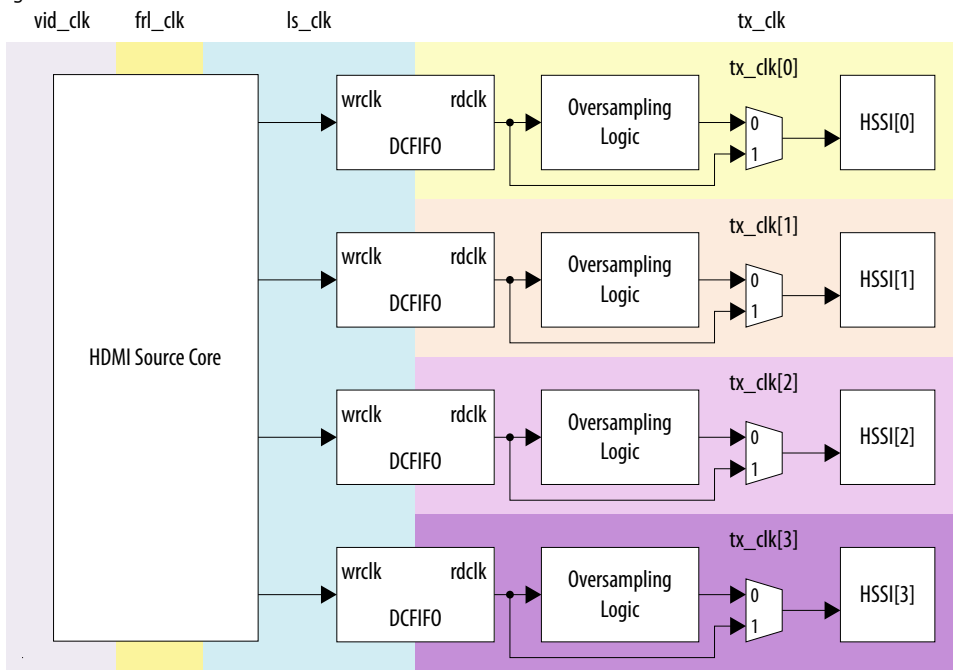

For HDMI source, you must instantiate 4 transceiver channels: 3 channels to transmit data and 1 channel to transmit clock information.

Figure 31. Source Clock Tree when Support FRL = 1

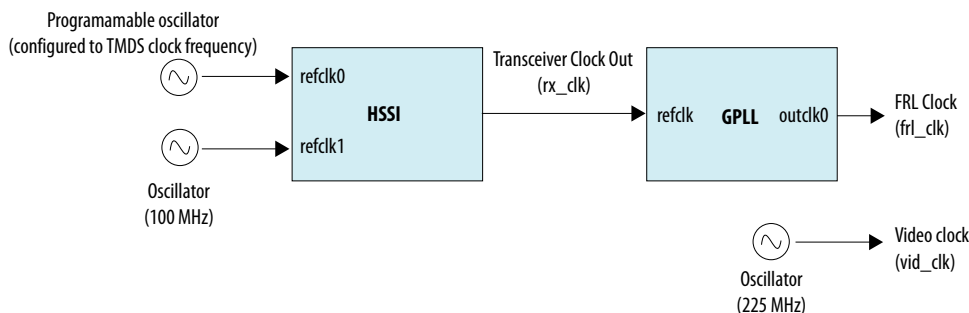

When Support FRL =1, the transceiver PLL has two reference clocks:

- Reference clock 0 supplied with arbitrary TMDS clock frequency from a programmable oscillator.
- Reference clock 1 supplied with free running 100 MHz clock.

The transceiver PLL switches between reference clock 0 and reference clock 1 in TMDS and FRL modes.

A general purpose phase-locked loop (GPLL), that is referenced by a Transceiver Clock Out (`rx_clk`) clock is used to generate the FRL clock (`frl_clk`). You can fix the video clock (`vid_clk`) at a static frequency of 225 MHz. The link speed clock (`ls_clk`) is not required when you turn on the **Support FRL** parameter. Refer to [Table 39](#) on page 89 for more details.

Figure 32. Source Clock Tree when Support FRL = 0

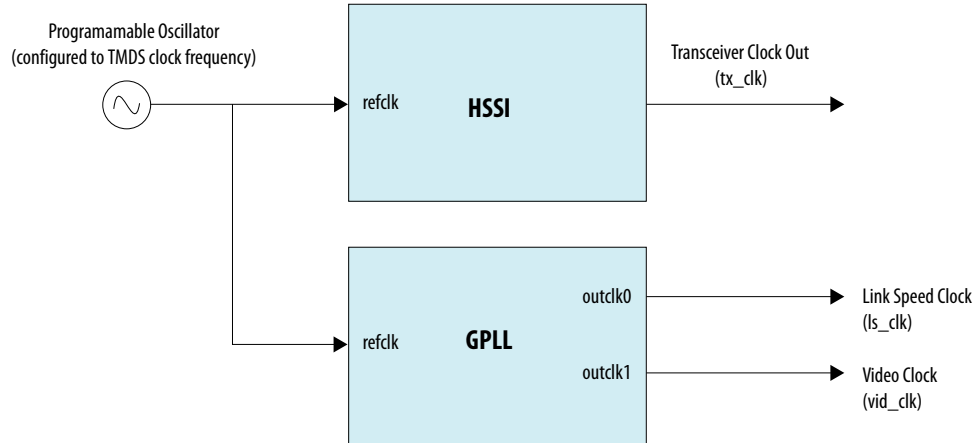

When Support FRL = 0, the transceiver PLL in high-speed serial interface (HSSI) block only has one reference clock which supplied with arbitrary TMDS clock frequency from a programmable oscillator.

A general-purpose phase-locked loop (GPLL), that is referenced by same clock from the same programmable oscillator, is used to generate the video clock (`vid_clk`) and link speed clock (`ls_clk`). FRL clock (`frl_clk`) is not required when you turn off the Support FRL parameter.

The video data clocks into the core at `vid_clk`, the TMDS or FRL data clocks out from the core at `tx_clk` (Support FRL = 1) or `ls_clk` (Support FRL = 0), and the FRL data clocks with `frl_clk`.

If an application requires low TMDS Bit Rate (below the transceiver minimum data rate requirement), then the application needs a user logic consisting of a DCFIFO and oversampling logic.

- The DCFIFO synchronizes the TMDS data from `ls_clk` to a faster transceiver output clock (`tx_clk[0]`). This DCFIFO is not required when Support FRL = 1.
- The oversampling logic repeats each bit of the TMDS data a given number of times.
- When you enable the oversampling control bit, the transceiver transmits the TMDS data between the HDMI source core and the oversampling logic.
- You can use `tx_clk[0]` across four channels if the transceiver is in bonding mode.

When Support FRL = 0, if an application does not require low TMDS Bit Rate, you can connect the core output directly to the transceiver with `tx_clk[0]` driving the core `ls_clk`. You do not require the GPLL to generate CLK1 (`ls_clk`).

Related Information

- [HDMI Hardware Design Examples for Arria V and Stratix V Devices](#) on page 22
- [HDMI Hardware Design Examples for Intel Arria 10, Intel Cyclone 10 GX, and Intel Stratix 10 Devices](#) on page 21

5.4. Link Training Procedure

The HDMI TX core does not handle the link training process.

Instead, the Nios II software manages the link training process, which is demonstrated in the Intel Arria 10/Intel Stratix 10 FRL design example.

Implement the link training external to the HDMI TX core according to the TX link training flow diagram shown below. The HDMI TX core generates different link training patterns on each lane based on your input through the `scdc_frl_pattern` port when `scdc_frl_start` is deasserted. When `scdc_frl_start` is asserted, the source core generates normal video.

Figure 33. Source Link Training Flow Diagram

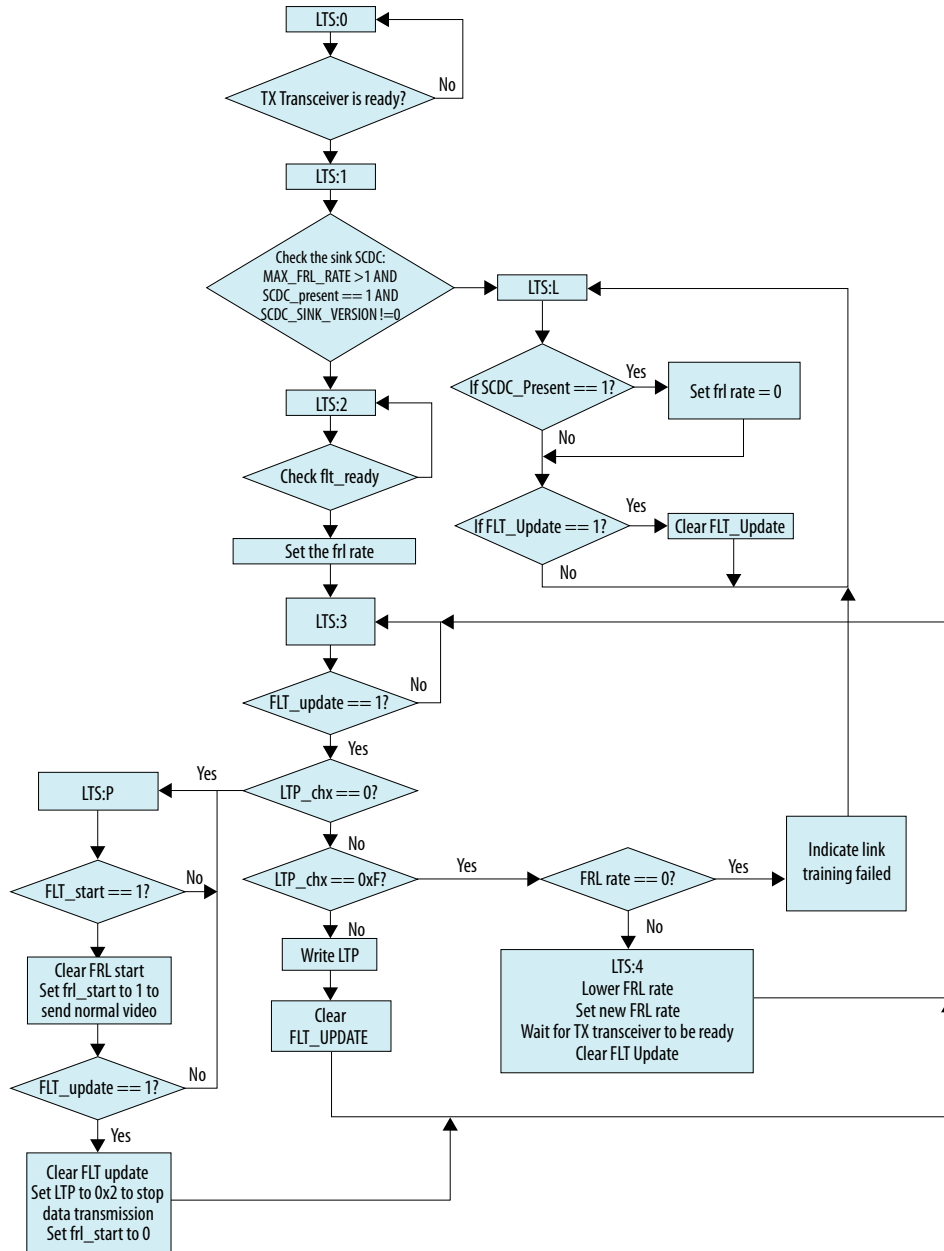

5.5. FRL Clcking Scheme

The HDMI 2.1 design is not limited to run at the actual pixel clock, but the data can be processed at a faster clock rate. HDMI 2.1 data flow metering expects the data to be evenly distributed across the link bandwidth if the data runs at a faster clock rate.

The vid_valid signal at the HDMI TX core qualifies the validity of the data for every clock cycle. Due to the timing consideration on maximum FRL data rate, the transceiver width is set to 40 bits.

In the FRL clock domain, the TX core always processes the data in multiple of 18 bits because of the 16B/18B encoder in the FRL path. The FRL modules can process N (FRL char per clock) FRL characters in parallel. However, the FRL modules always process 8 or 16 FRL characters per clock due to timing considerations.

Hence, f_{rl_clk} frequency = (data rate per lane * number of lanes) / (FRL char per clock*18)

The number of lanes is always four.

- For FRL rates 3–6, all four lanes carry the FRL characters.
- For FRL rates 1 and 2, only 3 lanes carry the FRL characters and 1 lane is unused.

Similarly, in the vid_clk domain, the TX core processes data in multiples of pixels (24 bits) in parallel. You can configure the number of pixels to be processed in parallel through the pixels per clock GUI parameter. However, due to timing consideration and backward compatibility, the IP sets the pixels per clock to 2 when you turn off **Support FRL**, and to 8 when you turn on **Support FRL**. Because the actual pixel clock may differ based on different resolutions, you can configure vid_clk to the maximum frequency per the specified link rate according to the following calculation:

vid_clk frequency = max supported pixel clock / pixel per clock

Note: Because vid_clk can be asynchronous to f_{rl_clk} and ls_clk , you can set the vid_clk frequency according to the maximum pixel frequency of the highest allowed resolution divided by 8, to simplify the clocking scheme. Intel recommends that you set the vid_clk frequency to 225 MHz, as demonstrated in the HDMI Intel FPGA IP FRL design example.

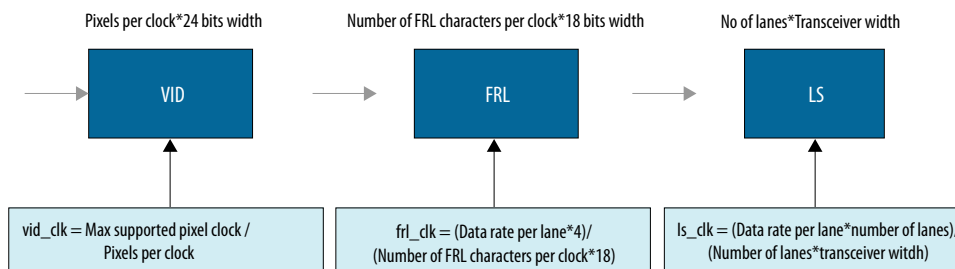

Table 39. Clock Frequencies for FRL Mode at Different Link Rates

| FRL Rate | TX PLL Refclk Frequency (MHz) | TX Clkout Frequency (MHz) | Maximum vid_clk Frequency (MHz) | f_rl_clk Frequency (MHz) | |
|----------|-------------------------------|---------------------------|---------------------------------|--------------------------|--------------------------|
| | | | | Intel Arria 10 Devices | Intel Stratix 10 Devices |
| 1 | 100.00 | 75.00 | 50.00 | 41.665 | 83.33 |
| 2 | 100.00 | 150.00 | 75.00 | 83.33 | 166.67 |
| 3 | 100.00 | 150.00 | 120.00 | 83.33 | 166.67 |
| 4 | 100.00 | 200.00 | 150.00 | 111.11 | 222.22 |
| 5 | 100.00 | 250.00 | 200.00 | 138.89 | 277.78 |
| 6 | 100.00 | 300.00 | 225.00 | 166.67 | 333.33 |

Table 40. Clock Frequencies for TMD5 Mode at Different Link Rates

| TMD5_BIT_CLOCK_RATE_IO | TMD5 Refclk (MHz) | | TX PLL Refclk Frequency (MHz) | | TX Clkout Frequency (MHz) | | Is_clk Frequency (MHz) | | vid_clk Frequency (MHz) | |
|----------------------------|-------------------|--------|-------------------------------|--------|---------------------------|--------|------------------------|--------|-------------------------|-------|
| | Min | Max | Min | Max | Min | Max | Min | Max | Min | Max |
| TMD5_BIT_CLOCK_RATE_IO = 0 | 25.00 | 100.00 | 25.00 | 100.00 | 100.00 | 400.00 | 12.50 | 50.00 | 3.13 | 12.5 |
| TMD5_BIT_CLOCK_RATE_IO = 0 | 100.00 | 340.00 | 100.00 | 340.00 | 50.00 | 170.00 | 50.00 | 170.00 | 12.50 | 42.50 |
| TMD5_BIT_CLOCK_RATE_IO = 1 | 85.00 | 150.00 | 85.00 | 150.00 | 170.00 | 300.00 | 170.00 | 300.00 | 42.50 | 75.00 |

5.6. Valid Video Data

You can generate video data using a different clock, other than `vid_clk` used in the HDMI TX core.

To generate video data, you need to use the actual pixel clock but `vid_clk` runs at a faster frequency. You can use a FIFO buffer to clock the data between the actual pixel clock and `vid_clk` while generating the valid video data (`vid_valid`) based on the inverted empty FIFO buffer.

For example, when operating at 8 Gbps link rate while transmitting 7680 x 4320p30 RGB resolution, a test pattern generator configured at 8 pixels in parallel runs at 148.5 MHz with the `vid_clk` domain of the HDMI TX core operating at 166.67 MHz. Like this case, not every `vid_clk` has valid video data. You can handle similar cases using the inverted empty signal of the DCFIFO.

When `vid_clk` runs at a faster frequency than the actual pixel clock frequency/pixels per clock, toggle `vid_valid` to qualify the video data.

Figure 34. Video Clock Running at Faster Frequency

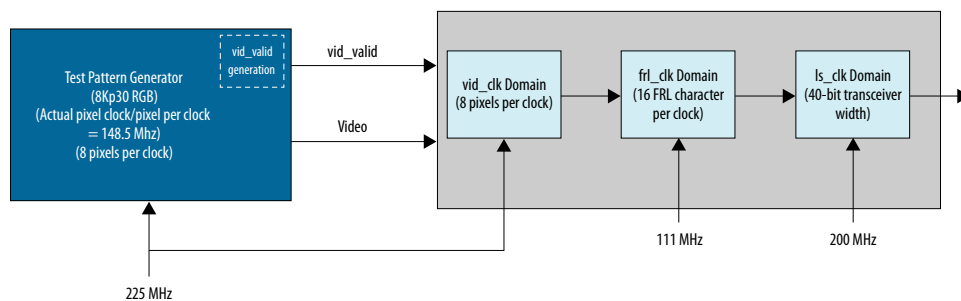

When you connect the test pattern generator to the HDMI TX core which runs at a faster clock rate, you need to generate the vid_valid to qualify validity of the pixel data. There is a requirement for the vid_valid generation to ensure the video data evenly distributed across the link bandwidth. An example for the vid_valid generation is as below:

First, you need to calculate the ratio of the pixel rate to the vid_clk frequency. For example, 8Kp30 video at 8 pixels per clock which runs at vid_clk of 225Mhz, the ratio is

$$\text{Ratio} = \frac{\text{Actual Pixel Clock}}{\text{Video Clock Frequency}} = \frac{148.5}{225} = \frac{33}{50}$$

Then, you will need to create a logic to generate the vid_valid according to the calculated ratio. For the example above, the vid_valid should be evenly asserted for 33 clock cycles for every 50 clock cycles.

Figure 35. Timing diagram for the vid_valid generation

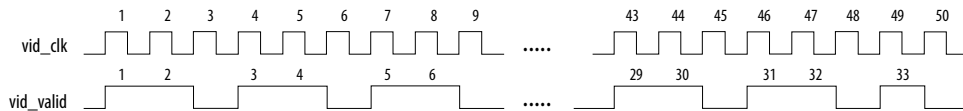

When vid_clk runs at the actual pixel clock frequency/pixels per clock, vid_valid should always remain asserted.

Figure 36. Video Clock Running at Actual Frequency

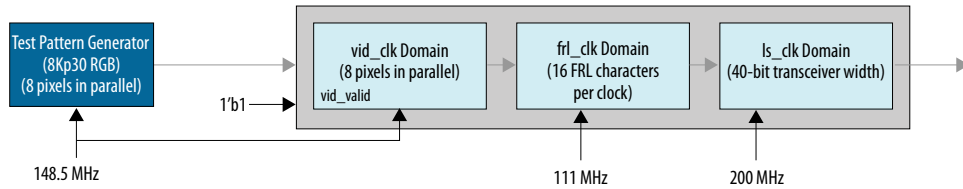

5.7. Source Deep Color Implementation When Support FRL = 0

When **Support FRL = 0**, you need to provide the ls_clk and vid_clk clocks according to the color depth ratio. The HDMI TX core carries 24, 30, 36 or 48 bits per pixel (bpp).

$$\text{ls_clk frequency} = \text{data rate per lane} / \text{effective transceiver width} = \text{data rate per lane} / 20$$

Note: The effective transceiver width in TMDS mode is also 20.

$$\text{vid_clk frequency} = (\text{data rate per lane} / \text{effective transceiver width}) / \text{color depth ratio}$$

Table 41. Color Depth Ratio for Bits per Color

| Bits per Color | Color Depth Ratio |
|----------------|-------------------|
| 8 | 1.6 |
| 10 | 1.25 |
| 12 | 1.5 |
| 16 | 2.0 |

Figure 37. Deep Color Implementation When Support FRL = 0

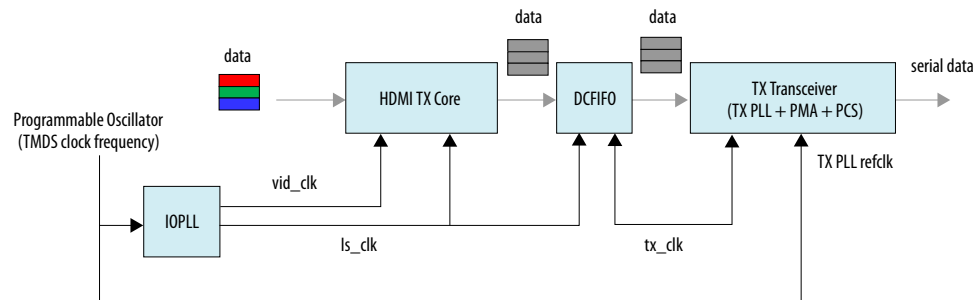

Figure 38. 10 Bits per Component (30 Bits per Pixel)

When operating in 10 bits per component, the vid_clk frequency to ls_clk frequency ratio is 4:5. For every 5 ls_clk cycles, there should be 4 vid_clk cycles.

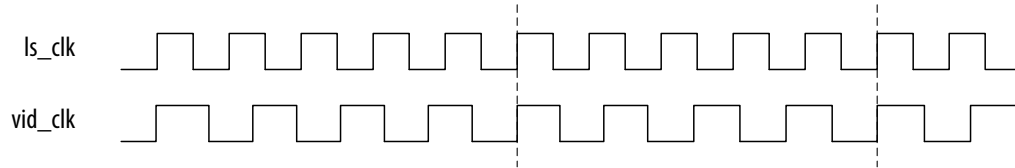

Figure 39. 12 Bits per Component (36 Bits per Pixel)

When operating in 12 bits per component, the vid_clk frequency to ls_clk frequency ratio is 2:3. For every 3 ls_clk cycles, there should be 2 vid_clk cycles.

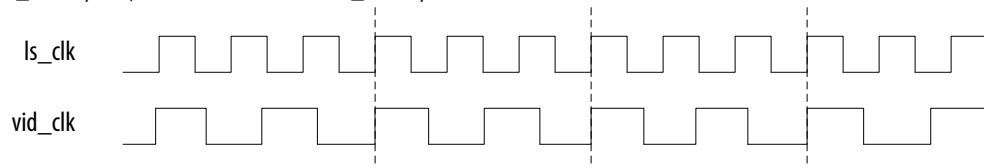
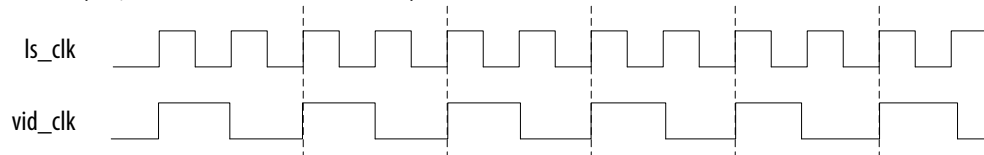

Figure 40. 16 Bits per Component (48 Bits per Pixel)

When operating in 16 bits per component, the vid_clk frequency to ls_clk frequency ratio is 1:2. For every 1 ls_clk cycle, there should be 2 vid_clk cycles.



5.8. Source Deep Color Implementation When Support FRL = 1

When **Support FRL** = 1, you can drive `vid_clk` regardless of the color depth ratio.

- In TMDS mode:
 $\text{vid_clk frequency} = (\text{data rate per lane} / \text{effective transceiver width}) / 4$
- In FRL mode:
 $\text{vid_clk frequency} = 225 \text{ MHz}$

Figure 41. Deep Color Implementation When Support FRL = 1

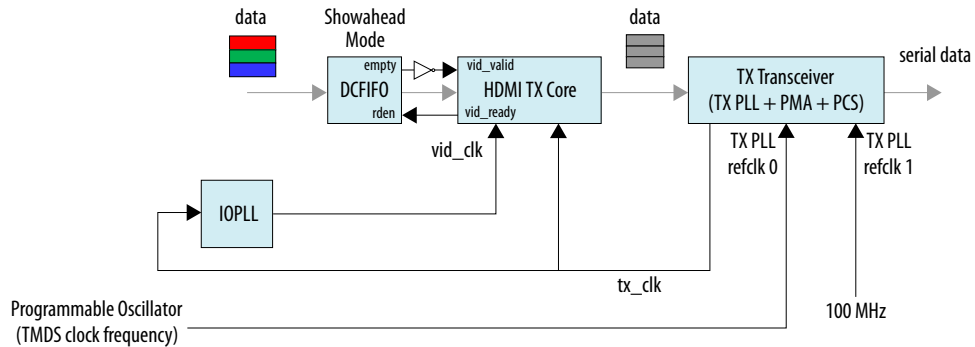

The `vid_ready` signal toggles to indicate if the HDMI TX core is ready to take in new video data. In this case, you can use a DCFIFO IP to store the video data when the HDMI TX core is not ready (`vid_ready` is low). You need to configure the DCFIFO IP to **show-ahead** mode, with the `vid_ready` signal connected to the `rden` signal of the DCFIFO IP.

When `vid_ready` is low, the DCFIFO IP holds the video data immediately. When `vid_ready` goes high, the HDMI TX core processes the stored data without losing any valid video data.

The inverted empty signal from the DCFIFO IP sets the `vid_valid` signal to the HDMI TX core.

Figure 42. 10 Bits per Component (30 Bits per Pixel)

When operating in 10 bits per component, the `vid_ready` signal is high for 4 out of 5 clock cycles. For every 5 clock cycles, the HDMI TX core processes 4 video data with 10 bits per component.

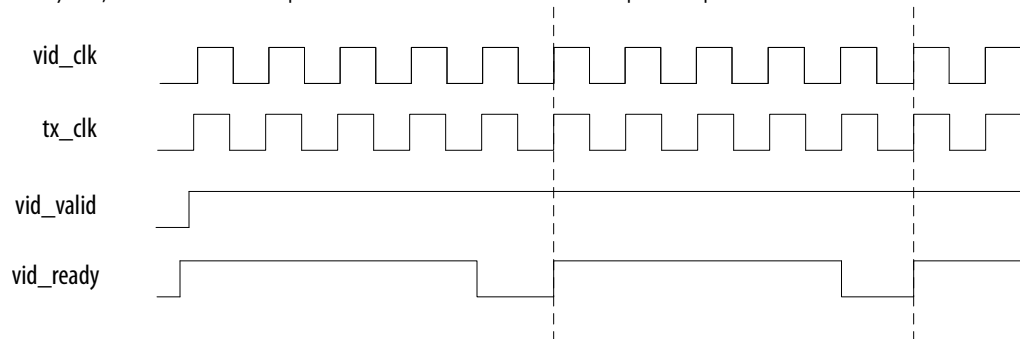

Figure 43. 12 Bits per Component (36 Bits per Pixel)

When operating in 12 bits per component, the `vid_ready` signal is high for 2 out of 3 clock cycles. For every 3 clock cycles, the HDMI TX core processes 2 video data with 12 bits per component.

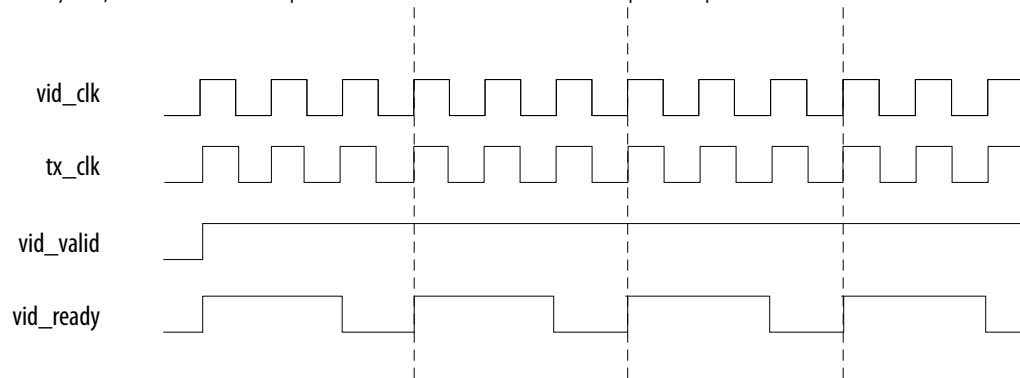
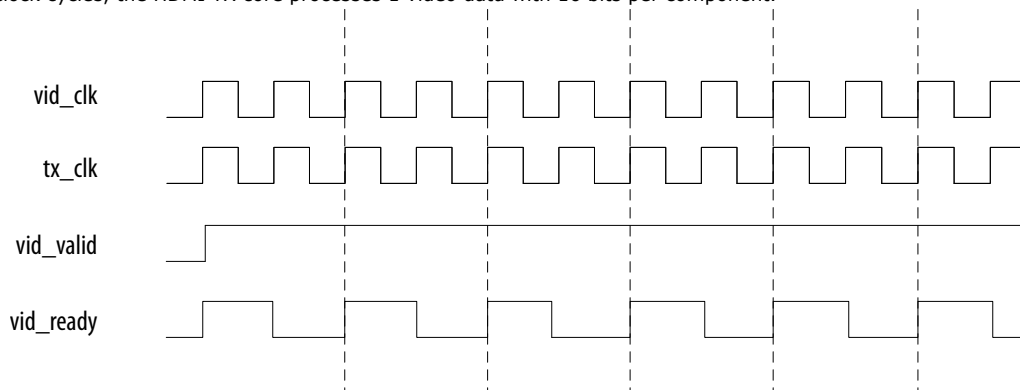

Figure 44. 16 Bits per Component (48 Bits per Pixel)

When operating in 16 bits per component, the `vid_ready` signal is high for 1 out of 2 clock cycles. For every 2 clock cycles, the HDMI TX core processes 1 video data with 16 bits per component.



5.9. Variable Refresh Rate (VRR) and Auto Low Latency Mode (ALLM)

HDMI TX core can support Variable Refresh Rate (VRR) transport as described in HDMI 2.1 specification. Section 7.6. VRR involves modification of the video vertical blanking timing, which is external to the HDMI TX core. After user generates the video with VRR transport, HDMI TX core is able to transmit this video through the FRL packets.

User can enable the Auto Low Latency Mode through the `ALLM_Mode` field (HF-VSI packet byte 5, bit 1). For the HDMI Forum-VSI InfoFrame (HF-VSIF) transmission, use external VSI by asserting control bit (`info_vsi[61]`) to 1 and send the data through the Auxiliary Data Port instead of `info_vsi` sidebands. Refer to HDMI 2.1 specification Section 10.2 HDMI Forum Vendor Specific InfoFrame for more information.

6. HDMI Sink

6.1. Sink Functional Description

The HDMI sink core provides direct connection to the Transceiver Native PHY through a 20-bit or 40-bit parallel data path. The clock domains for the auxiliary and audio ports, and the internal modules are different for FRL path and non-FRL path.

Figure 45. HDMI Sink Signal Flow Diagram for TMDs (Support FRL = 0) Design

The figure below shows the flow of the HDMI sink signals. The figure shows the various clocking domains used within the core.

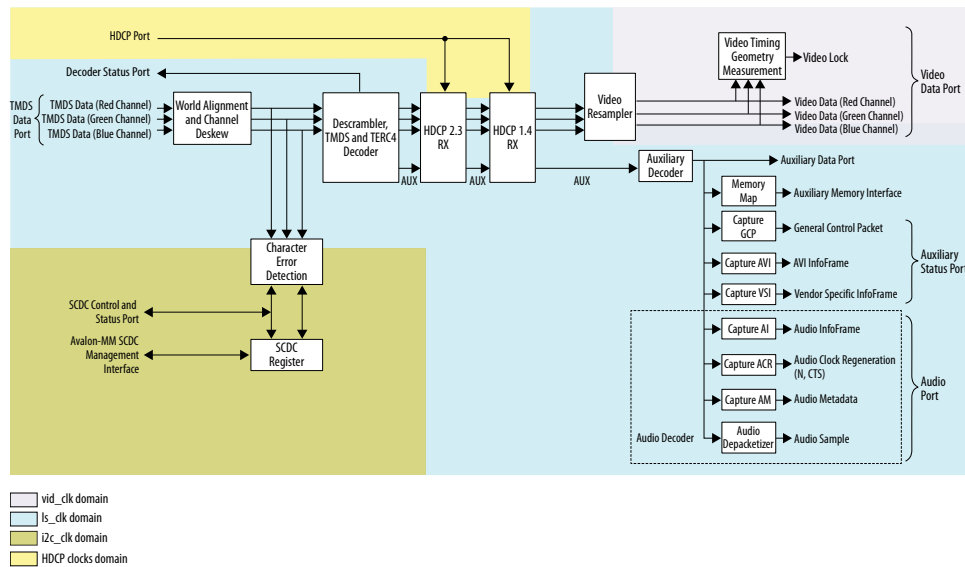

The sink core provides three (TMDs mode) or four (FRL mode) 20-bit or 40-bit data input paths corresponding to the color channels. The sink core clocks the three 20-bit or 40-bit channels from the transceiver outputs using the respective transceiver clock outputs.

- Blue channel: 0
- Green channel: 1
- Red channel: 2
- Clock channel: 3

Figure 46. HDMI Sink Signal Flow Diagram for Support FRL = 1 Design

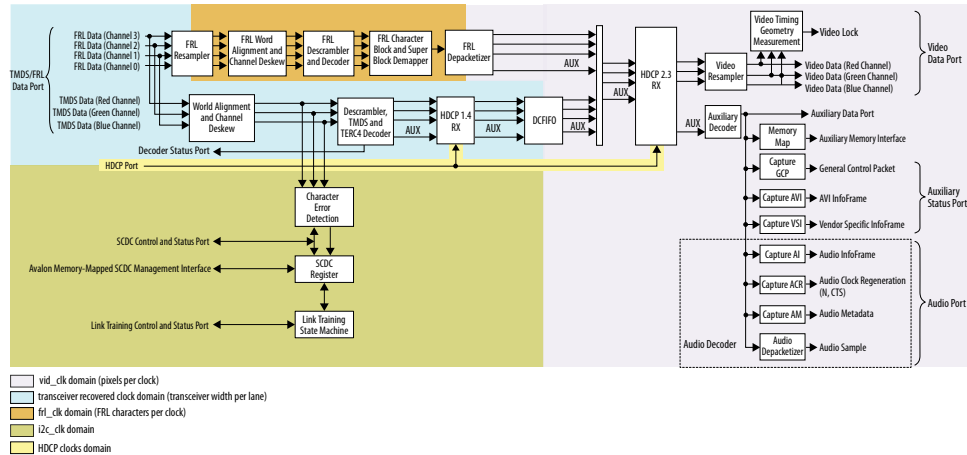

For **Support FRL = 1** design, in TMDS mode, a DCFIFO clocks the HDMI data stream from the scrambler, TMS/TERC4 decoder in the transceiver recovered clock domain to `vid_clk` domain. All the blocks in the FRL path and video data operate in `vid_clk` domain.

When operating TMDS mode, the sink core accepts three 20-bit data input paths corresponding to each color channel. The sink core clocks the three 20-bit channels from the transceiver outputs using respective transceiver clock outputs.

- Blue channel: Data channel 0
- Green channel: Data channel 1
- Red channel: Data channel 2

Note:

Data channel 3 is unused in TMDS mode. Data channels 0–3 are always 40-bit wide, but only 20 bits from the least significant bits are used in TMDS mode.

When operating in FRL mode, the sink core accepts four 40-bit data input paths corresponding to each FRL channel. The sink core clocks the four 40-bit channels from the transceiver outputs using respective transceiver clock outputs.

- FRL channel 0: Data channel 0
- FRL channel 1: Data channel 1
- FRL channel 2: Data channel 2
- FRL channel 3: Data channel 3

The sink core provides $N \times 48$ bit video data per channel for each color channel, where N is number of pixels per clock.

6.1.1. Sink Word Alignment and Channel Deskew

The input stage of the sink is responsible for synchronizing the incoming parallel data channels correctly. The synchronization is split to two stages: word alignment and channel deskew.

Table 42. Synchronization Stages

| Stage | Description | |
|----------------|--|--|
| Word Alignment | TMDS Mode | <ul style="list-style-type: none"> Correctly aligns the incoming parallel data to word boundaries using bit-slip and pattern-matching technique. TMDS encoding does not guarantee unique control codes, but the core can still use the sequence of continuous symbols found in data and video preambles to align. The alignment algorithm searches for 8 consecutive 0x54 or 0xab corresponding to the data and video preambles. <i>Note:</i> The preambles are also present in Digital Video Interface (DVI) coding. The alignment logic asserts a marker indicator when the 8 consecutive signals are detected. Similarly, the logic infers alignment loss when 8K symbol clocks elapse without a single marker assertion. <i>Note:</i> If you are using Intel Arria 10 or Intel Cyclone 10 GX devices, soft word alignment logic in the HDMI RX core is disabled for HDMI 2.0 resolution (data rate >3.4 Gbps). Hard transceiver PCS word alignment is used with some control logic to achieve faster word alignment with more optimized resource utilization. Refer to the design example user guides for more information. <i>Note:</i> If you are using Intel Stratix 10 devices, the HDMI RX core uses a new word alignment algorithm logic to achieve fast word alignment time for HDMI 2.0 resolution (data rate >3.4Gbps). |
| | FRL Mode | <ul style="list-style-type: none"> Correctly aligns the incoming parallel data to word boundaries using bit-slip and pattern-matching technique. FRL encoding uses unique Scrambler Reset (SR) and Start of Super Block (SSB) characters to achieve alignment. The FRL encoding loses lock when it does not receive the SR or SSB on one lane while other lane receive SR or SSB continuously for seven times. |
| Channel Deskew | <ul style="list-style-type: none"> When the data channels are aligned, the core then attempts to deskew each channel. The sink core deskews at the rising edge of the marker insertion. For every correct deskewed lane, the marker insertion will appear in all three TMDS encoded streams. The sink core deskews using three dual-clock FIFOs. The dual-clock FIFOs also synchronize all three data streams to the blue channel clock to be used later throughout the decoder core. | |

Figure 47. Channel Deskew DCFIFO Arrangement

The figure below shows the signal flow diagram of the deskew logic.

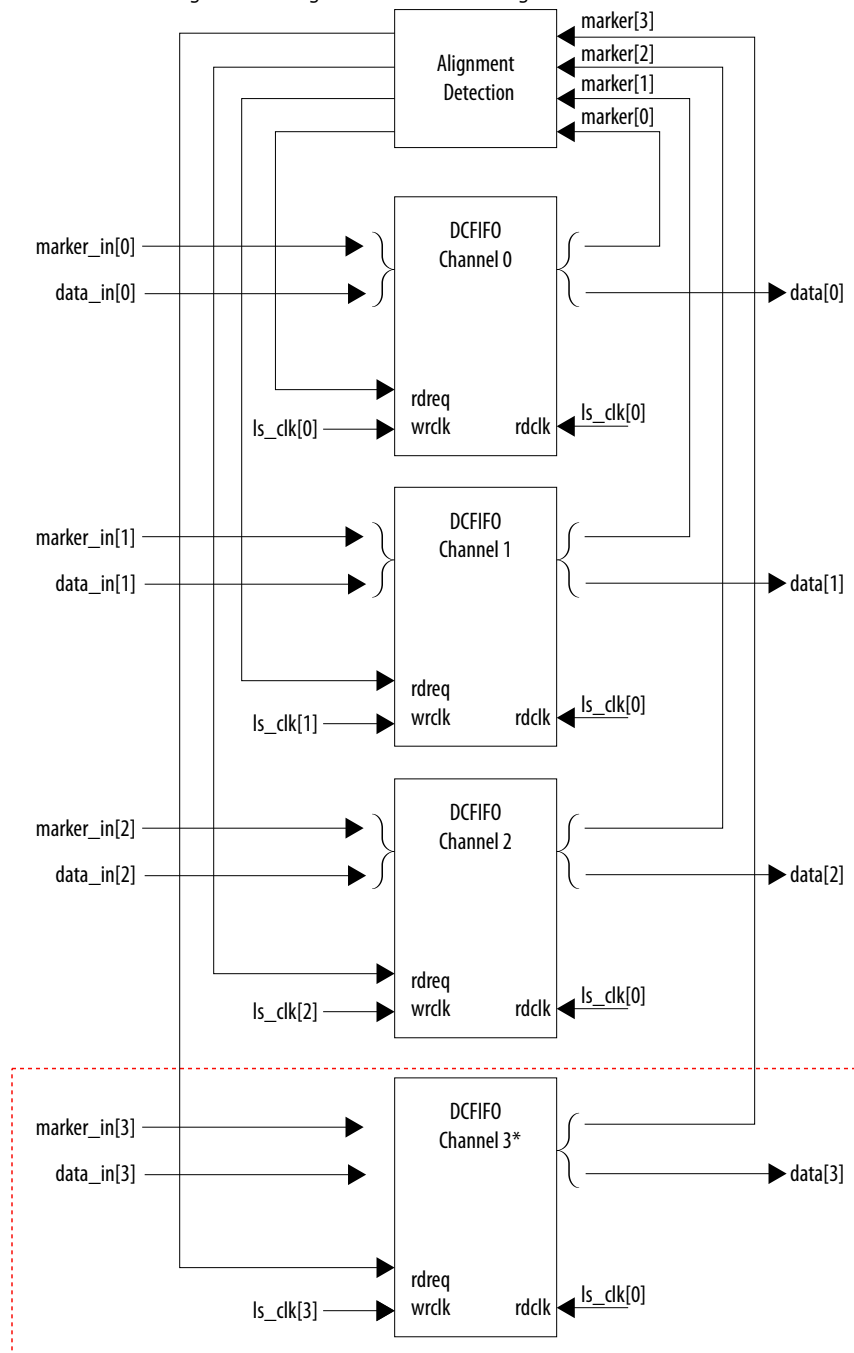

* Channel 3 is applicable only for FRL mode.

The FIFO read signal of the channels is normally asserted. The sink core deasserts a particular FIFO read signal if a marker appears at its output and not in the other two FIFO outputs. By deasserting, the sink core stalls the data stream for sufficient cycles to remove the channel skew. If any of the FIFO channels overflow, the sink core asserts a reset signal which propagates backwards to the word alignment logic.

6.1.2. Sink Descrambler, TMDS/TERC4 Decoder

The sink TMDS/TERC4 decoder follows the HDMI/DVI specification. The core enable descrambling automatically when it detects the `Scramble_Enable` bit of the SCDC registers.

The sink core feeds the aligned channels into the TMDS/TERC4 decoder. You can parameterize the decoder to operate in 1, 2, or 4 TMDS symbols per clock. If you choose 2 or 4 TMDS symbols per clock, the decoder will produce 2 or 4 decoded symbols per clock. The decoded symbols per clock output supports high pixel clock resolutions on low-end FPGA devices.

6.1.3. Sink Auxiliary Decoder

The sink core decodes the auxiliary data path into a 72-bit wide standard packet stream. The stream contains a valid, start-of-packet (SOP) and end-of-packet (EOP) marker.

Figure 48. Auxiliary Data Stream Signal

The figure below shows the relationship between the data bit-field and its clock cycle based on 1-, 2-, or 4-symbol per clock mode.

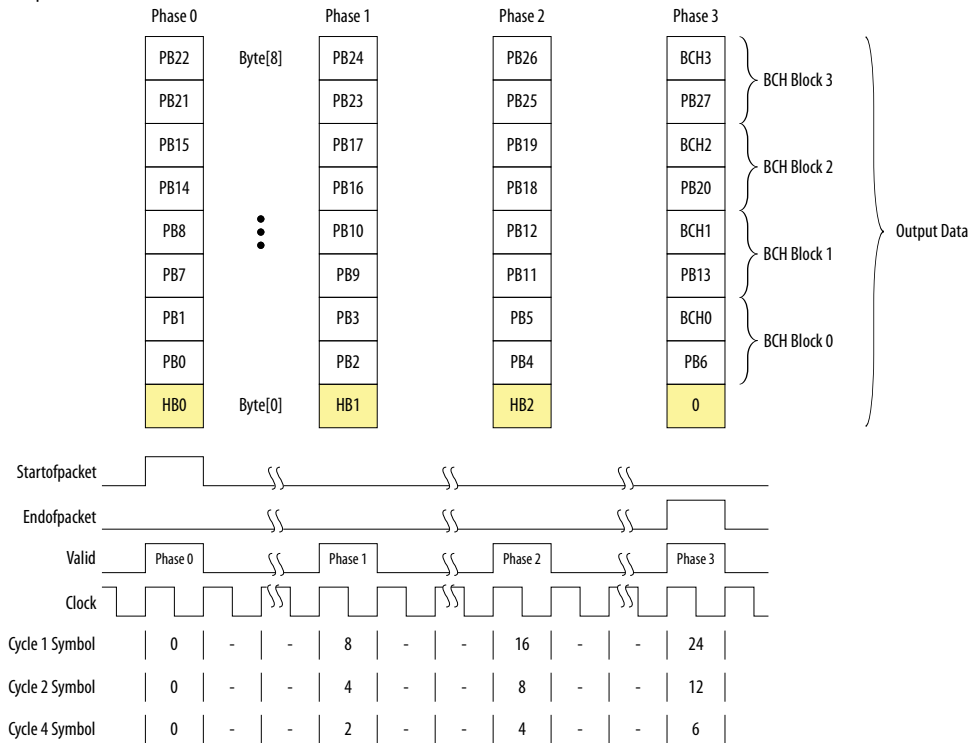

The data output at EOP contains the received BCH error correcting code. The sink core does not perform any error correction within the core. The auxiliary data is available outside the core.

Note: You can find the bit-field nomenclature in the *HDMI 2.0b Specification*.

6.1.4. Sink Auxiliary Packet Capture

To simplify user applications and minimize external logic, the core captures 3 different packet types and presents the packets outside the core.

These packets are: General Control Packet (GCP), Auxiliary Video Information (AVI) InfoFrame, and HDMI Vendor Specific InfoFrame (VSI).

The GCP, AVI and VSI bit-fields (excluding control bit) are defined in [Table 22](#) on page 50. [Table 23](#) on page 50. and [Table 25](#) on page 52 respectively with reserved bits return 0.

6.1.5. Sink Video Resampler

The video resampler consists of a gearbox and a dual-clock FIFO (DCFIFO).

The gearbox converts 8-bpc data to 8-, 10-, 12- or 16-bpc data based on the current color depth. The GCP conveys the color depth (bpp) information.

Figure 49. Sink Resampler Signal Flow Diagram

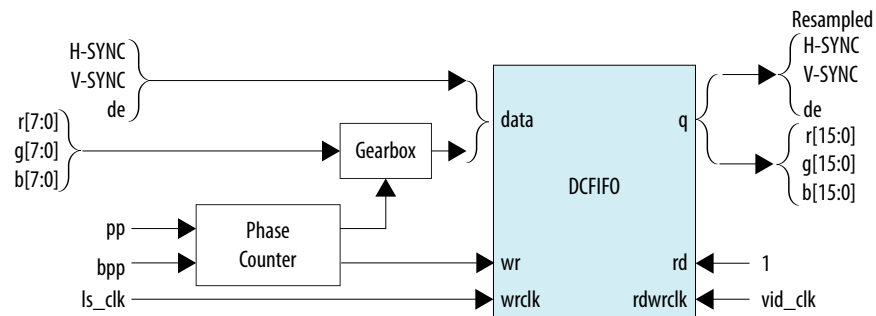

The resampler adheres to the recommended phase count method described in *HDMI 1.4b Specification Section 6.5*.

- To keep the source and sink resamples synchronized, the source must send the packing-phase (pp) value to the sink during the vertical blanking phase, using the general control packet.
- The pp corresponds to the phase of the last pixel in the last active video line.
- The phase-counter logic compares its own pp value to the pp value received in the general control packet and *slips* the phase count if the two pp values do not agree.

The output from the resampler is fixed at 16 bpc. When the resampler operates in lower color depths, the low order bits are zero. The pixel data output format across color space are described in Figure 10-12.

6.1.6. Sink Auxiliary Data Port

The auxiliary port is attached to external memory. This port allows you to write packets to memory for use outside the HDMI core.

The core calculates the address for the data port using the header byte of the received packet. The core writes packet types 0–15 into a contiguous memory region.

Figure 50. Typical Application of AUX Packet Register Interface

The figure below shows a typical application of the auxiliary data port.

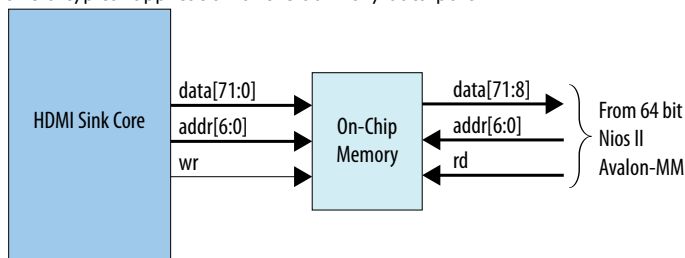

Table 43. Auxiliary Packet Memory Map

| Memory Start Address | Packet Name |
|----------------------|--|
| 0 | NULL PACKET |
| 4 | Audio Clock Regeneration (N/CTS) |
| 8 | Audio Sample |
| 12 | General Control |
| 16 | ACP Packet |
| 20 | ISRC1 Packet |
| 24 | ISRC2 Packet |
| 28 | One Bit Audio Sample Packet 5.3.9 |
| 32 | DST Audio Packet |
| 36 | High Bitrate (HBR) Audio Stream Packet |
| 40 | Gamut Metadata Packet |
| 44 | 3D Audio Sample Packet |
| 48 | One Bit 3D Audio Sample Packet |
| 52 | Audio Metadata Packet |
| 56 | Multi-Stream Audio Sample Packet |
| 60 | One Bit Multi-Stream Audio Sample Packet |
| 64 | Vendor-Specific InfoFrame |
| 68 | AVI InfoFrame |
| 72 | Source Product Descriptor InfoFrame |
| 76 | Audio InfoFrame |
| <i>continued...</i> | |

| Memory Start Address | Packet Name |
|----------------------|---------------------------------------|
| 80 | MPEG Source InfoFrame |
| 84 | TSC VBI InfoFrame |
| 88 | Dynamic Range and Mastering InfoFrame |

Table 44. Packet Payload Data Byte

The table below lists the representation of each packet payload data byte.

| Word Offset | Byte Offset | | | | | | | | |
|-------------|-------------|------|------|------|------|------|------|-----|-------|
| | 8 | 7 | 6 | 5 | 4 | 3 | 2 | 1 | 0 |
| 0 | PB22 | PB21 | PB15 | PB14 | PB8 | PB7 | PB1 | PB0 | HB0 |
| 1 | PB24 | PB23 | PB17 | PB16 | PB10 | PB9 | PB3 | PB2 | HB1 |
| 2 | PB26 | PB25 | PB19 | PB18 | PB12 | PB11 | PB5 | PB4 | HB2 |
| 3 | BCH3 | PB27 | BCH2 | PB20 | BCH1 | PB13 | BCH0 | PB6 | HBCH0 |

Note: The packet fields (PB0-PB26) are described in the HDMI 1.4b Specification (Chapter 8.2.1).

6.1.6.1. Sink General Control Packet (GCP)

Table 45. Sink GCP Bit-Fields

This table lists the controllable bit-fields for the Source `gcp[5:0]` port.

| Bit Field | Name | Value | | | | Comment |
|-----------|------------------|--|-----|-----|-----|----------------------------------|
| gcp[3:0] | Color Depth (CD) | CD3 | CD2 | CD1 | CD0 | Color depth |
| | | 0 | 0 | 0 | 0 | Color depth not indicated |
| | | 0 | 1 | 0 | 0 | 8 bpc or 24 bits per pixel (bpp) |
| | | 0 | 1 | 0 | 1 | 10 bpc or 30 bpp |
| | | 0 | 1 | 1 | 0 | 12 bpc or 36 bpp |
| | | 0 | 1 | 1 | 1 | 16 bpc or 48 bpp |
| | | Others | | | | |
| gcp[4] | Set_AVMUTE | Refer to <i>HDMI 1.4b Specification Section 5.3.6.</i> | | | | |
| gcp[5] | Clear_AVMUTE | Refer to <i>HDMI 1.4b Specification Section 5.3.6.</i> | | | | |

6.1.6.2. Sink Auxiliary Video Information (AVI) InfoFrame Bit-Fields

Table 46. Sink Auxiliary Video Information (AVI) InfoFrame for Support FRL = 0 Designs

The signal bundle is clocked by `ls_clk` for **Support FRL = 0** designs.

| Bit-field | Name | Description |
|-----------|----------|---|
| 7:0 | Checksum | Checksum |
| 9:8 | S | Scan information |
| 11:10 | B | Bar info data valid |
| 12 | A0 | Active information present |
| 14:13 | Y | RGB or YCbCr indicator |
| 15 | Reserved | Returns 0 |
| 19:16 | R | Active format aspect ratio |
| 21:20 | M | Picture aspect ratio |
| 23:22 | C | Colorimetry (for example: ITU BT.601, BT.709) |
| 25:24 | SC | Non-uniform picture scaling |
| 27:26 | Q | Quantization range |
| 30:28 | EC | Extended colorimetry |
| 31 | ITC | IT content |
| 38:32 | VIC | Video format identification code |
| 39 | Reserved | Returns 0 |
| 43:40 | PR | Picture repetition factor |
| 45:44 | CN | Content type |
| 47:46 | YQ | YCC quantization range |
| 63:48 | ETB | Line number of end of top bar |
| 79:64 | SBB | Line number of start of bottom bar |
| 95:80 | ELB | Pixel number of end of left bar |
| 111:96 | SRB | Pixel number of start of right bar |

Table 47. Sink Auxiliary Video Information (AVI) InfoFrame for Support FRL = 1 Designs

The signal bundle is clocked by `ls_clk` for **Support FRL = 1** designs.

| Bit-field | Name | Description |
|-----------|----------|----------------------------|
| 7:0 | Checksum | Checksum |
| 9:8 | S | Scan information |
| 11:10 | B | Bar info data valid |
| 12 | A0 | Active information present |
| 14:13 | Y | RGB or YCbCr indicator |
| 15 | Reserved | Returns 0 |

continued...

| Bit-field | Name | Description |
|-----------|-------------|---|
| 19:16 | R | Active format aspect ratio |
| 21:20 | M | Picture aspect ratio |
| 23:22 | C | Colorimetry (for example: ITU BT.601, BT.709) |
| 25:24 | SC | Non-uniform picture scaling |
| 27:26 | Q | Quantization range |
| 30:28 | EC | Extended colorimetry |
| 31 | ITC | IT content |
| 38:32 | VIC | Video format identification code |
| 39 | Reserved | Returns 0 |
| 43:40 | PR | Picture repetition factor |
| 45:44 | CN | Content type |
| 47:46 | YQ | YCC quantization range |
| 63:48 | ETB | Line number of end of top bar |
| 79:64 | SBB | Line number of start of bottom bar |
| 95:80 | ELB | Pixel number of end of left bar |
| 111:96 | SRB | Pixel number of start of right bar |
| 115:112 | F143-F140 | Future use 14 |
| 119:116 | ACE3-ACE0 | Additional colorimetry extension |
| 121:120 | AVI Version | Refer to HDMI 2.1 Spec section 10.1 for more details. |
| 122 | - | Reserved |

6.1.6.3. Sink HDMI Vendor Specific InfoFrame (VSI)

Table 48. Sink HDMI Vendor Specific InfoFrame Bit-Fields

The table below lists the bit-fields for VSI (as described in *HDMI 1.4b Specification Section 8.2.3*).

The signal bundle is clocked by `1s_clk` for Support FRL=0 and `tx_clk` when Support FRL=1.

| Bit-field | Name | Description |
|-----------|--------------------------|--|
| 4:0 | Length | Length of HDMI VSI payload |
| 12:5 | Checksum | Checksum |
| 36:13 | IEEE | 24-bit IEEE registration identifier (0x000C03) |
| 41:37 | Reserved | Reserved (0) |
| 44:42 | HDMI_Video_Format | Structure of extended video formats exclusively defined in <i>HDMI 1.4b Specification</i> |
| 52:45 | HDMI_VIC or 3D_Structure | <ul style="list-style-type: none"> If HDMI_Video_Format = 3'h1, [52:45] = HDMI proprietary video format identification code If HDMI_Video_Format = 3'h2, [52:49] = 3D_Structure and [48:45] = Reserved (0) |
| 56:53 | Reserved | Reserved (0) |
| 60:57 | 3D_Ext_Data | 3D extended data |

6.1.7. Sink Audio Decoder

The Audio Clock Regeneration packet transmits the CTS and N values required to synthesize the audio sample clock. The core also makes the CTS and N values available outside the core.

An audio clock synthesizer uses a phase-counter to recover the audio sample rate. The output from the audio clock synthesizer generates a valid pulse at the same rate as the audio sample clock from the attached source device. This valid pulse is available outside the core as an audio sample valid signal. This signal reads from a FIFO, which governs the rate of audio samples. The audio depacketizer drives the input to the FIFO.

The audio depacketizer extracts the 32-bit audio sample data from the incoming Audio Sample packets. The Audio Sample packets can hold from one to four sample data values. The audio format indicates the format of the received audio data as defined in [Table 26](#) on page 54.

The Audio InfoFrame and Audio Metadata packets are not used within the core. The packets are captured and presented outside the core. The bit fields (excluding control bit) are defined in [Table 27](#) on page 56, [Table 28](#) on page 57, [Table 29](#) on page 57, and [Table 30](#) on page 57 with reserved bits return 0.

6.1.7.1. Audio InfoFrame (AI) Bundle Bit-Fields

Table 49. Source Audio InfoFrame Bundle Bit-Fields

Table below lists the AI signal bit-fields (as described in *HDMI 1.4b Specification Section 8.2.2*). The signal bundle is clocked by `ls_clk` for **Support FRL = 0** designs and by `vid_clk` for **Support FRL = 1** designs.

| Bit-field | Name | Description |
|-----------|----------|---------------------------------------|
| 7:0 | Checksum | Checksum |
| 10:8 | CC | Channel count |
| 11 | Reserved | Returns 0 |
| 15:12 | CT | Audio format type |
| 17:16 | SS | Bits per audio sample |
| 20:18 | SF | Sampling frequency |
| 23:21 | Reserved | Returns 0 |
| 31:24 | CXT | Audio format type of the audio stream |
| 39:32 | CA | Speaker location allocation FL, FR |
| 41:40 | LFEPBL | LFE playback level information, dB |
| 42 | Reserved | Returns 0 |
| 46:43 | LSV | Level shift information, dB |
| 47 | DM_INH | Down-mix inhibit flag |

6.1.7.2. Audio Metadata Bundle Bit-Fields

Table 50. Audio Metadata Bundle Bit-Fields for Packet Header and Control

Table below lists the AM signal bit-fields for packet header (as described in the *HDMI 2.0b Specification Section 8.3*) and control.

| Bit-field | Name | Description |
|-----------|---------------|---|
| 0 | 3D_AUDIO | <ul style="list-style-type: none"> 1: Transmits 3D audio 0: Transmits MST audio |
| 2:1 | NUM_VIEWS | Number of views for an MST stream |
| 4:3 | NUM_AUDIO_STR | Number of audio streams - 1 |

Table 51. Audio Metadata Bundle Bit-Fields for Packet Content when 3D_AUDIO = 1

Table below lists the AM signal bit-fields for packet content when 3D_AUDIO = 1 (as described in the *HDMI 2.0b Specification Section 8.3.1*).

| Bit-field | Name | Description |
|-----------|----------|---|
| 9:5 | 3D_CC | Channel count of the transmitted 3D audio |
| 12:10 | Reserved | Reserved (0) |
| 16:13 | ACAT | Audio channel allocation standard |
| 20:17 | Reserved | Reserved (0) |
| 28:21 | 3D_ACAT | Channel/Speaker allocation for 3D audio |
| 164:29 | Reserved | Reserved (0) |

Table 52. Audio Metadata Bundle Bit-Fields for Packet Content when 3D_AUDIO = 0

Table below lists the AM signal bit-fields for packet content when 3D_AUDIO = 0 (as described in the *HDMI 2.0b Specification Section 8.3.2*).

| Bit-field | Name | Description |
|---------------------|-------------------|---|
| 5 | Multiview_Left_0 | Left stereoscopic picture (Subpacket 0 in MST Audio Sample Packet) |
| 6 | Multiview_Right_0 | Right stereoscopic picture (Subpacket 0 in MST Audio Sample Packet) |
| 12:7 | Reserved | Reserved (0) |
| 15:13 | Suppl_A_Type_0 | Supplementary audio type (Subpacket 0 in MST Audio Sample Packet) |
| 16 | Suppl_A_Mixed_0 | Mix of main audio components and a supplementary audio track (Subpacket 0 in MST Audio Sample Packet) |
| 17 | Suppl_A_Valid_0 | Audio stream contains a supplementary audio track (Subpacket 0 in MST Audio Sample Packet) |
| 19:18 | Reserved | Reserved (0) |
| 20 | LC_Valid_0 | Validity of Language_Code (Subpacket 0 in MST Audio Sample Packet) |
| 44:21 | Language_Code_0 | Audio stream language (Subpacket 0 in MST Audio Sample Packet) |
| 45 | Multiview_Left_1 | Left stereoscopic picture (Subpacket 1 in MST Audio Sample Packet) |
| <i>continued...</i> | | |

| Bit-field | Name | Description |
|-----------|-------------------|---|
| 46 | Multiview_Right_1 | Right stereoscopic picture (Subpacket 1 in MST Audio Sample Packet) |
| 52:47 | Reserved | Reserved (0) |
| 55:53 | Suppl_A_Type_1 | Supplementary audio type (Subpacket 1 in MST Audio Sample Packet) |
| 56 | Suppl_A_Mixed_1 | Mix of main audio components and a supplementary audio track (Subpacket 1 in MST Audio Sample Packet) |
| 57 | Suppl_A_Valid_1 | Audio stream contains a supplementary audio track (Subpacket 1 in MST Audio Sample Packet) |
| 59:58 | Reserved | Reserved (0) |
| 60 | LC_Valid_1 | Validity of Language_Code (Subpacket 1 in MST Audio Sample Packet) |
| 84:61 | Language_Code_1 | Audio stream language (Subpacket 1 in MST Audio Sample Packet) |
| 85 | Multiview_Left_2 | Left stereoscopic picture (Subpacket 2 in MST Audio Sample Packet) |
| 86 | Multiview_Right_2 | Right stereoscopic picture (Subpacket 2 in MST Audio Sample Packet) |
| 92:87 | Reserved | Reserved (0) |
| 95:93 | Suppl_A_Type_2 | Supplementary audio type (Subpacket 2 in MST Audio Sample Packet) |
| 96 | Suppl_A_Mixed_2 | Mix of main audio components and a supplementary audio track (Subpacket 2 in MST Audio Sample Packet) |
| 97 | Suppl_A_Valid_2 | Audio stream contains a supplementary audio track (Subpacket 2 in MST Audio Sample Packet) |
| 99:98 | Reserved | Reserved (0) |
| 100 | LC_Valid_2 | Validity of Language_Code (Subpacket 2 in MST Audio Sample Packet) |
| 124:101 | Language_Code_2 | Audio stream language (Subpacket 2 in MST Audio Sample Packet) |
| 125 | Multiview_Left_3 | Left stereoscopic picture (Subpacket 3 in MST Audio Sample Packet) |
| 126 | Multiview_Right_3 | Right stereoscopic picture (Subpacket 3 in MST Audio Sample Packet) |
| 132:127 | Reserved | Reserved (0) |
| 135:133 | Suppl_A_Type_3 | Supplementary audio type (Subpacket 3 in MST Audio Sample Packet) |
| 136 | Suppl_A_Mixed_3 | Mix of main audio components and a supplementary audio track (Subpacket 3 in MST Audio Sample Packet) |
| 137 | Suppl_A_Valid_3 | Audio stream contains a supplementary audio track (Subpacket 3 in MST Audio Sample Packet) |
| 139:138 | Reserved | Reserved (0) |
| 140 | LC_Valid_3 | Validity of Language_Code (Subpacket 3 in MST Audio Sample Packet) |
| 164:141 | Language_Code_3 | Audio stream language (Subpacket 3 in MST Audio Sample Packet) |

6.1.8. Status and Control Data Channel (SCDC) Interface

For applications using the features in HDMI 2.0b onwards, the core provides a memory slave port to the SCDC registers.

This memory slave port connects to an I²C slave component. The `TMDS_Bit_clock_Ratio` output from the SCDC interface indicates when the core requires the TMDS Bit Rate/TMDS Clock Rate ratio of 40. This bit is also stored in its corresponding field in the SCDC registers.

The *HDMI 2.0b Specification* requires the core to respond to the presence of the 5V input from the connector and the state of the HPD signal. The 5V input and HPD signal are used in the register mechanism updates. The signals are synchronous to the `i2c_clk` clock domain. You must create a 100-ms delay on the HPD signal externally to the core.

For more information about the Status and Control Data Channel, you may refer to *HDMI 2.0b Specification Chapter 10.4*. You can obtain the address map for the registers in the *HDMI 2.0b Specification*.

6.1.9. HDCP 1.4 RX Architecture

The HDCP 1.4 receiver block decrypts the protected video and auxiliary data from the connected HDCP 1.4 device. The HDCP 1.4 receiver block has identical structure layers as the HDCP 1.4 transmitter block.

Figure 51. Architecture Block Diagram of HDCP 1.4 RX IP

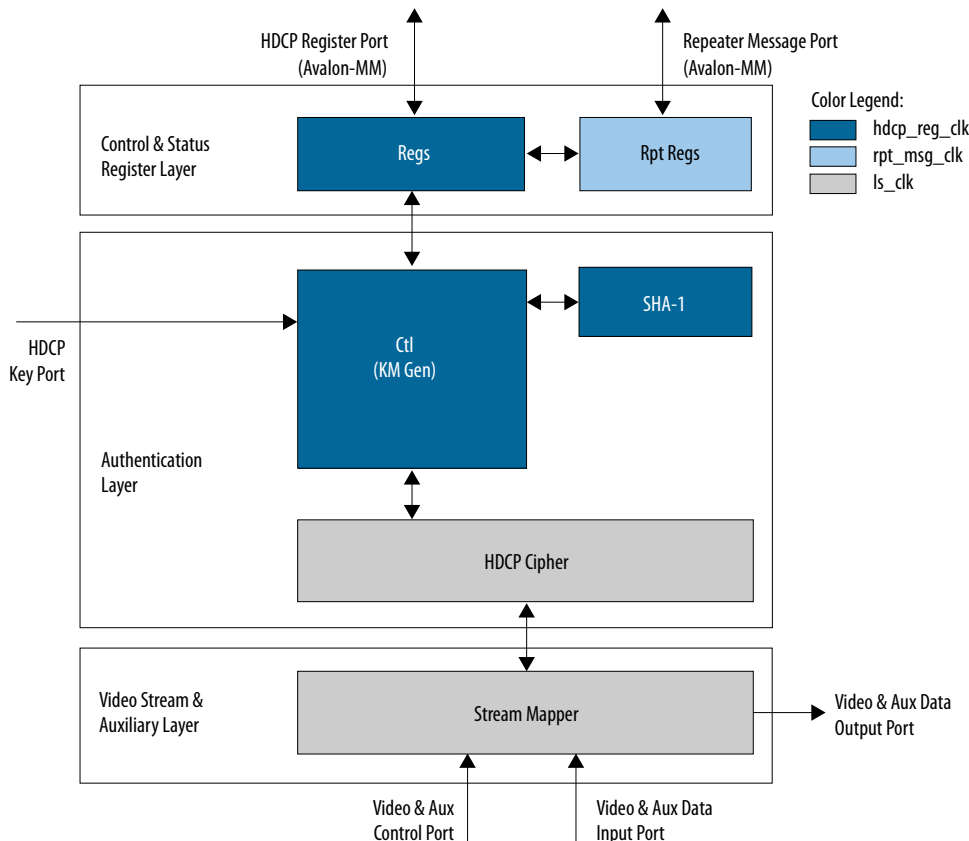

The HDCP 1.4 RX core is fully autonomous. For HDMI application, the transmitter drives the HDCP 1.4 RX core using the standard DDC interface supporting I²C protocol. You need an I²C slave externally to drive the IP through the HDCP Register Port (Avalon-MM).

The HDCP specifications requires the HDCP 2.3 RX core to be programmed with the DCP-issued production key – Device Private Keys (Bkeys) and Key Selection Vector (Bksv). The IP retrieves the key from the on-chip memory externally to the core through the HDCP Key Port. The on-chip memory must store the key data in the arrangement shown in the table below.

Table 53. HDCP 1.4 RX Key Port Addressing

| Address | Content |
|---------|---------------------|
| 6'h28 | {16'd0, Bksv[39:0]} |
| 6'h27 | Bkeys39[55:0] |
| 6'h26 | Bkeys38[55:0] |
| ... | ... |
| 6'h01 | Bkeys01[55:0] |
| 6'h00 | Bkeys00[55:0] |

The Video Stream and Auxiliary Layer receives audio and video content over its Video and Aux Data Input Port, and performs the decryption operation. The Video Stream and Auxiliary Layer detects the Encryption Status Signaling (ESS) provided by the HDMI IP to determine when to decrypt frames.

To implement the HDCP 1.4 RX core as a repeater upstream interface, the IP must propagate certain information such as KSV list and Bstatus to the upstream transmitter and to be used for SHA-1 hash digest. The repeater downstream interface (TX) must provide this information using the Repeater Message Port (Avalon-MM). You can use the same clock source to drive the clocking for the HDCP Register Port and Repeater Message Port.

The RX registers mapping defined in the following table is equivalent to the address space for HDCP 1.4 receiver defined in the HDCP specification.

Table 54. HDCP 1.4 RX Registers Mapping

| Address | Register | R/W | Reset | Bit | Bit Name | Description |
|-------------|-----------|-----|-------|-----|----------|--|
| 0x00 | BKSV0 | RO | - | 7:0 | - | Bit [7:0] of HDCP Receiver KSV. |
| 0x01 | BKSV1 | | - | 7:0 | - | Bit [15:8] of HDCP Receiver KSV. |
| 0x02 | BKSV2 | | - | 7:0 | - | Bit [23:16] of HDCP Receiver KSV. |
| 0x03 | BKSV3 | | - | 7:0 | - | Bit [31:24] of HDCP Receiver KSV. |
| 0x04 | BKSV4 | | - | 7:0 | - | Bit [39:32] of HDCP Receiver KSV. |
| 0x05-0x07 | Rsvd | RO | 0x00 | 7:0 | - | Reserved. All bytes read as 0x00. |
| 0x08 | RI_PRIME0 | RO | 0x00 | 7:0 | - | Link verification response. Bit [7:0] of Ri'. |
| 0x09 | RI_PRIME1 | | 0x00 | 7:0 | - | Link verification response. Bit [15:8] of Ri'. |
| 0x0A | PJ_PRIME | RO | 0x00 | 7:0 | - | Reserved. All bytes read as 0x00. |
| 0x0B – 0x0F | Rsvd | RO | 0x00 | 7:0 | - | Reserved. All bytes read as 0x00. |
| 0x10 | AKSV0 | WO | 0x00 | 7:0 | - | Bit [7:0] of HDCP Transmitter KSV. |
| 0x11 | AKSV1 | | 0x00 | 7:0 | - | Bit [15:8] of HDCP Transmitter KSV. |
| 0x12 | AKSV2 | | 0x00 | 7:0 | - | Bit [23:16] of HDCP Transmitter KSV. |
| 0x13 | AKSV3 | | 0x00 | 7:0 | - | Bit [31:24] of HDCP Transmitter KSV. |
| 0x14 | AKSV4 | | 0x00 | 7:0 | - | Bit [39:32] of HDCP Transmitter KSV. |
| 0x15 | AINFO | WO | 0x00 | 7:0 | - | Reserved. |
| 0x16 – 0x17 | Rsvd | RO | 0x00 | 7:0 | - | Reserved. All bytes read as 0x00. |

continued...

| Address | Register | R/W | Reset | Bit | Bit Name | Description |
|---------|--------------|-----|-------|-----|----------|--|
| 0x18 | AN0 | WO | 0x00 | 7:0 | - | Bit [7:0] of HDCP Session Random Number An. |
| 0x19 | AN1 | | 0x00 | 7:0 | | Bit [15:8] of HDCP Session Random Number An. |
| 0x1A | AN2 | | 0x00 | 7:0 | | Bit [23:16] of HDCP Session Random Number An. |
| 0x1B | AN3 | | 0x00 | 7:0 | | Bit [31:24] of HDCP Session Random Number An. |
| 0x1C | AN4 | | 0x00 | 7:0 | | Bit [39:32] of HDCP Session Random Number An. |
| 0x1D | AN5 | | 0x00 | 7:0 | | Bit [47:40] of HDCP Session Random Number An. |
| 0x1E | AN6 | | 0x00 | 7:0 | | Bit [55:48] of HDCP Session Random Number An. |
| 0x1F | AN7 | | 0x00 | 7:0 | | Bit [63:56] of HDCP Session Random Number An. |
| 0x20 | V_PRIME_H0_0 | RO | 0x00 | 7:0 | - | H0 part of SHA-1 hash value used in the authentication protocol HDCP repeaters. Bit [7:0] of H0 value. |
| 0x21 | V_PRIME_H0_1 | | 0x00 | 7:0 | | Bit [15:8] of H0 value. |
| 0x22 | V_PRIME_H0_2 | | 0x00 | 7:0 | | Bit [23:16] of H0 value. |
| 0x23 | V_PRIME_H0_3 | | 0x00 | 7:0 | | Bit [31:24] of H0 value. |
| 0x24 | V_PRIME_H1_0 | RO | 0x00 | 7:0 | - | H1 part of SHA-1 hash value used in the authentication protocol HDCP repeaters. Bit [7:0] of H1 value. |
| 0x25 | V_PRIME_H1_1 | | 0x00 | 7:0 | | Bit [15:8] of H1 value. |
| 0x26 | V_PRIME_H1_2 | | 0x00 | 7:0 | | Bit [23:16] of H1 value. |
| 0x27 | V_PRIME_H1_3 | | 0x00 | 7:0 | | Bit [31:24] of H1 value. |
| 0x28 | V_PRIME_H2_0 | RO | 0x00 | 7:0 | - | H2 part of SHA-1 hash value used in the authentication protocol HDCP repeaters. Bit [7:0] of H2 value. |
| 0x29 | V_PRIME_H2_1 | | 0x00 | 7:0 | | Bit [15:8] of H2 value. |
| 0x2A | V_PRIME_H2_2 | | 0x00 | 7:0 | | Bit [23:16] of H2 value. |
| 0x2B | V_PRIME_H2_3 | | 0x00 | 7:0 | | Bit [31:24] of H2 value. |
| 0x2C | V_PRIME_H3_0 | RO | 0x00 | 7:0 | - | H3 part of SHA-1 hash value used in the authentication protocol HDCP repeaters. Bit [7:0] of H3 value. |
| 0x2D | V_PRIME_H3_1 | | 0x00 | 7:0 | | Bit [15:8] of H3 value. |
| 0x2E | V_PRIME_H3_2 | | 0x00 | 7:0 | | Bit [23:16] of H3 value. |
| 0x2F | V_PRIME_H3_3 | | 0x00 | 7:0 | | Bit [31:24] of H3 value. |

continued...

| Address | Register | R/W | Reset | Bit | Bit Name | Description |
|-------------|--------------|-----|-------|-----|-----------------------|--|
| 0x30 | V_PRIME_H4_0 | RO | 0x00 | 7:0 | - | H4 part of SHA-1 hash value used in the authentication protocol HDCP repeaters. Bit [7:0] of H4 value. |
| 0x31 | V_PRIME_H4_1 | | 0x00 | 7:0 | | Bit [15:8] of H4 value. |
| 0x32 | V_PRIME_H4_2 | | 0x00 | 7:0 | | Bit [23:16] of H4 value. |
| 0x33 | V_PRIME_H4_3 | | 0x00 | 7:0 | | Bit [31:24] of H4 value. |
| 0x34 – 0x3F | Rsvd | RO | 0x00 | 7:0 | - | Reserved. All bytes read as 00. |
| 0x40 | BCAPS | RO | 0x00 | 7 | HDMI_RESERVED | 0 = Receiver not capable of supporting HDMI 1 = Receiver capable of supporting HDMI |
| | | | | 6 | REPEATER | HDCP repeater capability. 0 = Receiver is not a repeater. 1 = Receiver is a repeater. |
| | | | | 5 | READY | KSV FIFO ready. When set to 1, the receiver has built the list of attached KSVs and computed the verification value V'. This value is always 0 during the computation of V'. |
| | | | | 4 | FAST | This bit reads as 0. |
| | | | | 3:2 | Reserved | These bits read as 0. |
| | | | | 1 | FEATURES_1_1 | Reserved. This bit reads as 0. |
| | | | | 0 | FAST_REAUTHENTICATION | This bit reads as 1. |
| 0x41 | BSTATUS0 | RO | 0x00 | 7 | MAX_DEVS_EXCEEDED | Topology error indicator. When set to 1, more than 127 downstream devices, or the capacity of the KSV FIFO, are attached. |
| | | | | 6:0 | DEVICE_COUNT | Total number of attached downstream devices. Always 0 for HDCP Receivers. This count does not include the HDCP Repeater itself, but only downstream devices downstream from the HDCP Repeater. |
| 0x42 | BSTATUS1 | RO | 0x00 | 7:6 | Rsvd | These bits read as 0. |
| | | | | 5 | HDMI_RESERVED_2 | Reserved for future possible HDMI use. |
| | | | | 4 | HDMI_MODE | HDMI mode. When set to 1, the HDCP Receiver has transitioned from DVI mode to HDMI mode. |

continued...

| Address | Register | R/W | Reset | Bit | Bit Name | Description |
|--------------|----------|-----|-------|-----|----------------------|---|
| | | | | 3 | MAX_CASCADE_EXCEEDED | Topology error indicator. When set to 1, more than 7 levels of video repeater have been cascaded together. |
| | | | | 2:0 | DEPTH | 3-bit repeater cascade depth. This value gives the number of attached levels through the connection topology. |
| 0x43 | KSV_FIFO | RO | 0x00 | 7:0 | - | Key selection vector FIFO. Used to pull downstream KSVs from HDCP Repeaters. |
| 0x44 – 0xBF | Rsvd | RO | 0x00 | 7:0 | - | Reserved. All bytes read as 0x00. |
| 0xC0 – 0x100 | DBG | RW | 0x00 | 7:0 | - | Implementation-specific debug registers. |

Table 55. HDCP 1.4 RX Repeater Registers Mapping

| Address | Register | R/W | Reset | Bit | Bit Name | Description |
|---------|--------------|-----|------------|-------|----------|---|
| 0x00 | RPT_KSV_LIST | WO | 0x00000000 | 31:8 | Reserved | Reserved |
| | | | | 7:0 | KSV_LIST | Byte write KSV List in big endian order. |
| 0x01 | RPT_BSTATUS | RW | 0x00000000 | 31:19 | Reserved | Reserved |
| | | | | 18 | REQUEST | Read-only. Asserted by the core to request for KSV_LIST and BSTATUS. This usually happens when re-authentication is triggered by the connected upstream. Note that when REQUEST is asserted, the READY should also be asserted. |
| | | | | 17 | READY | Read-only. Asserted by the core to indicate KSV_LIST and BSTATUS are processed. Write KSV_LIST and BSTATUS after this bit is asserted. |
| | | | | 16 | VALID | Set to 1 after KSV_LIST and BSTATUS are written. Self-cleared by the core after KSV_LIST and BSTATUS are read. |
| | | | | 15:0 | BSTATUS | [15:12]: Reserved. [11]: MAX_CASCADE_EXCEEDED [10:8]: DEPTH [7]: MAX_DEVS_EXCEEDED [6:0]: DEVICE_COUNT |
| 0x02 | RPT_MISC | RW | - | 31:1 | Reserved | Reserved. |
| | | | | 0 | REPEATER | Set to 0 if no downstream is connected or if the connected downstream is not HDCP 1.4-capable. This means the receiver IP core is an end-point receiver rather than a repeater. |

continued...

| Address | Register | R/W | Reset | Bit | Bit Name | Description |
|---------|----------|-----|-------|-----|----------|---|
| | | | | | | Set to 1 if the connected downstream is HDCP-capable. |

6.1.10. HDCP 2.3 RX Architecture

The receiver block decrypts the protected video and auxiliary data from the connected HDCP 2.3 device. The HDCP 2.3 receiver block has identical structure layers as the HDCP 2.3 transmitter block.

Figure 52. Architecture Block Diagram of HDCP 2.3 RX IP

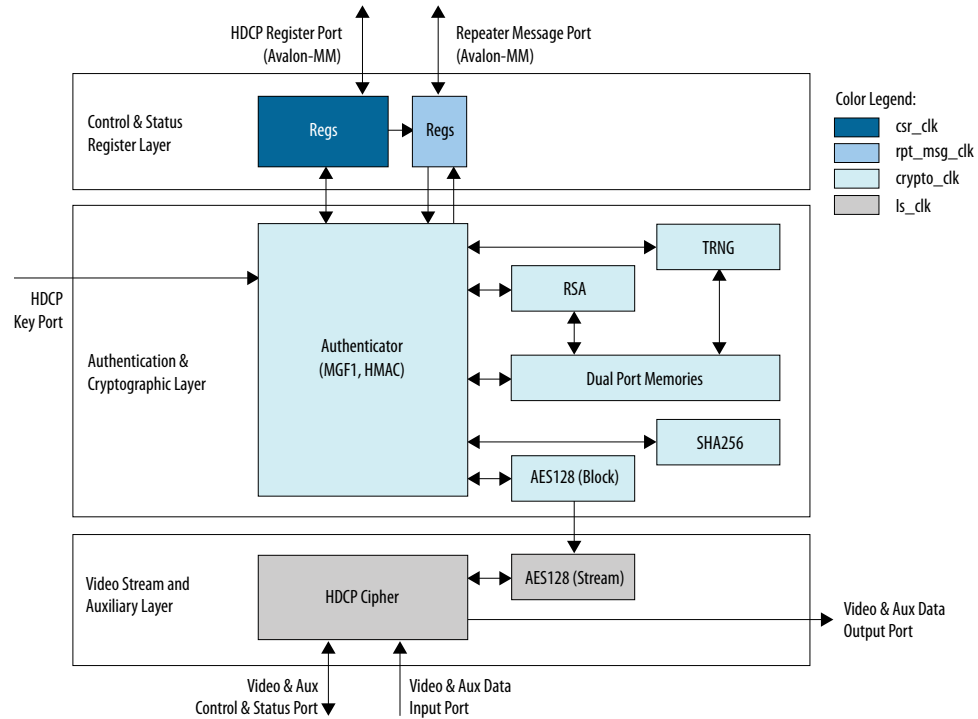

The HDCP 2.3 RX core is fully autonomous. For HDMI application, the transmitter drives the HDCP 2.3 RX core using the standard DDC interface supporting I²C protocol.

The HDCP specifications requires the HDCP 2.3 RX core to be programmed with the DCP-issued production key – Global Constant (Ic128), RSA private key (kprivrx) and RSA Public Key Certificate (certrx). The IP retrieves the key from the on-chip memory externally to the core through the HDCP Key Port. The on-chip memory must store the key data in the arrangement shown in the table below.

Table 56. HDCP 2.3 RX Key Port Addressing

| Address | Content |
|---------------------|---------------|
| 8'hE3 | Ic128[127:96] |
| 8'hE2 | Ic128[95:64] |
| <i>continued...</i> | |

| Address | Content |
|-------------|----------------------------|
| 8'hE1 | lc128[63:32] |
| 8'hE0 | lc128[31:0] |
| 8'hDF | kprivrx_p[511:480] |
| ... | ... |
| 8'hD0 | kprivrx_p[31:0] |
| 8'hCF | kprivrx_q[511:480] |
| ... | ... |
| 8'hC0 | kprivrx_q[31:0] |
| 8'hBF | kprivrx_dp[511:480] |
| ... | ... |
| 8'hB0 | kprivrx_dp[31:0] |
| 8'hAF | kprivrx_dq[511:480] |
| ... | ... |
| 8'hA0 | kprivrx_dq[31:0] |
| 8'h9F | kprivrx_qinv[511:480] |
| ... | ... |
| 8'h90 | kprivrx_qinv[31:0] |
| 8'h83-8'h8F | Reserved |
| 8'h82 | {16'd0, certrx[4175:4160]} |
| 8'h81 | certrx[4159:4128] |
| ... | ... |
| 8'h01 | certrx[63:32] |
| 8'h00 | certrx[31:0] |

The Video Stream and Auxiliary Layer receives audio and video content over its Video and Aux Data Input Port, and performs the decryption operation. The Video Stream and Auxiliary Layer detects the Encryption Status Signaling (ESS) provided by the HDMI IP to determine when to decrypt frames.

To implement the HDCP 2.3 RX core as a repeater upstream interface, the IP must propagate certain information such as `ReceiverID List` and `RxInfo` to the upstream transmitter and to be used for HMAC computation. The repeater downstream interface (TX) must provide this information using the Repeater Message Port (Avalon-MM). You can use the same clock source to drive the clocking for the HDCP Register Port and Repeater Message Port.

The RX registers mapping defined in the following table is equivalent to the address space for HDCP 2.3 receiver defined in the HDCP specification.

Table 57. HDCP 2.3 RX Registers Mapping

| Address | Register | R/W | Reset | Bit | Bit Name | Description |
|-------------|---------------|-----|-------|-----|------------|--|
| 0x44 – 0x4F | Rsvd | RO | 0x00 | 7:0 | Reserved | Reserved. |
| 0x50 | HDCP2VERSION | RO | 0x04 | 7:3 | Reserved | Reserved. |
| | | | | 2 | HDCP22 | When set to 1, the core supports HDCP 2.2 and above. |
| | | | | 1:0 | Reserved | Reserved. |
| 0x51 – 0x5F | Rsvd | RO | 0x00 | 7:0 | Reserved | Reserved. |
| 0x60 | WRITE_MESSAGE | WO | 0x00 | 7:0 | WR_MSG | Variable length message written by the transmitter as a single burst write to this address. |
| 0x61 – 0x6F | Rsvd | RO | 0x00 | 7:0 | Reserved | Reserved. |
| 0x70 | RXSTATUS0 | RO | 0x00 | 7:0 | MSG_SIZE0 | The lower part of message size in bytes available at the receiver for reading by the transmitter. |
| 0x71 | RXSTATUS1 | RO | 0x00 | 7:4 | Reserved | Reserved |
| | | | | 3 | REAUTH_REQ | When set to 1, indicates the link integrity check failure at the receiver (including upstream side of the repeater) or the upstream side of the repeater has transitioned into an unauthenticated state. Self-cleared by the core on every new authentication initiated by the AKE_Init message. |
| | | | | 2 | READY | When set to 1, the repeater has built the list of downstream Receiver IDs and computed the verification value V'. Self-cleared by the core as soon as the RepeaterAuth_Send_ReceiverID_List message has been read by the transmitter or on every new authentication request by the transmitter. |
| | | | | 1:0 | MSG_SIZE1 | The upper part of message size in bytes available at the receiver for reading by the transmitter. |
| 0x72 – 0x7F | Rsvd | RO | 0x00 | 7:0 | Reserved | Reserved. |
| 0x80 | READ_MESSAGE | RO | 0x00 | 7:0 | RD_MSG | Variable length message read by the transmitter as a single burst read from this address. |
| 0x81 – 0xBF | Rsvd | RO | 0x00 | 7:0 | Reserved | Reserved. |
| 0xC0 – 0xFF | DBG | RW | 0x00 | 7:0 | DBG_REGS | Implemented specific debug registers. |

Table 58. HDCP 2.3 RX Repeater Registers Mapping

| Address | Register | R/W | Reset | Bit | Bit Name | Description |
|---------|-----------------|-----|------------|-------|-------------|--|
| 0x00 | RPT_RCVDID_LIST | WO | 0x00000000 | 31:8 | Reserved | Reserved |
| | | | | 7:0 | RCVDID_LIST | Byte write ReceiverID_List in big endian order. |
| 0x01 | RPT_RXINFO | RW | 0x00000000 | 31:19 | Reserved | Reserved |
| | | | | 18 | REQUEST | Read-only. Asserted by the core to request for RCVDID_LIST and RXINFO. This usually happens when re-authentication is triggered by the connected upstream. Note that when REQUEST is asserted, the READY should also be asserted. |
| | | | | 17 | READY | Read-only. Asserted by the core to indicate RCVDID_LIST and RXINFO are processed. Write RCVDID_LIST and RXINFO after this bit is asserted. |
| | | | | 16 | VALID | Set to 1 after RCVDID_LIST and RXINFO are written. Self-cleared by the core after RCVDID_LIST and RXINFO are read. |
| | | | | 15:0 | RXINFO | [15:12]: Reserved. [11:9]: DEPTH [8:4]: DEVICE_COUNT [3]: MAX_DEVS_EXCEEDED [2]: MAX_CASCADE_EXCEEDED [1]: HDCP2_REPEATER_DOWNSTREAM [0]: HDCP1_DEVICE_DOWNSTREAM |
| 0x02 | RPT_TYPE | RO | 0x00000000 | 31:9 | Reserved | Reserved |
| | | | | 8 | VALID | Asserted by the core to indicate content stream TYPE is valid. Self-cleared by the core after TYPE is read. |
| | | | | 7:0 | TYPE | 0x00: Type 0 Content Stream 0x01: Type 1 Content Stream 0x02-0xFF: Reserved. Treated as Type 1 Content Stream. |
| 0x03 | RPT_MISC | RW | 0x00000000 | 31:1 | Reserved | Reserved. |
| | | | | 0 | REPEATER | Set to 0 if no downstream is connected or if the connected downstream is not HDCP 2.3-capable. This means the receiver IP core is an end-point receiver rather than a repeater. Set to 1 if the connected downstream is HDCP-capable. |

6.1.11. FRL Depacketizer

FRL depacketizer reconstructs the FRL packets into HDMI data.

FRL depacketizer contains a mixed-width DCFIFO to clock the data from the `frl_clk` domain to the `vid_clk` domain. This block also demaps the HDMI data from number of FRL characters per clock * 16 bits to pixels per clock * 24 bits, where number of FRL characters per clock is always 16 and pixels per clock is always 8 in FRL mode.

6.1.12. Sink FRL Character Block and Super Block Demapper

The HDMI RX core extracts the FRL character blocks from the FRL super block, and demaps the FRL packets from the FRL characters in the FRL character blocks.

The HDMI RX core achieves FRL character alignment based on the Start Super Block (SSB) or Scrambler Reset (SR) character proceeded FRL super block.

6.1.13. Sink FRL Descrambler and Decoder

FRL data is decoded using 16B/18B decoder. The HDMI RX core then descrambles the decoded data to obtain the FRL super block.

6.1.14. Sink FRL Resampler

FRL resampler consists of the mixed-width DCFIFO to clock the FRL characters from the transceiver recovered clock domain to `frl_clk` domain.

The mixed-width FIFO buffer demaps the FRL data in effective transceiver width bits to FRL characters per clock*18 bits. For FRL mode, the transceiver width is always 40 bits and number of FRL characters per clock is 8 or 16.

6.1.15. RX Oversampler

The HDMI design requires oversampling on the RX side in case the data received is below the minimum data rate of the transceiver at 1 Gb/s.

The oversampling factor on the RX is set to 5. For example, a video resolution with TMDS Bit Rates of 742.5 Mb/s should configure the transceiver to operate at 5 times its data rate, which is 3.7125 Gb/s.

Figure 53. RX Oversampler Block

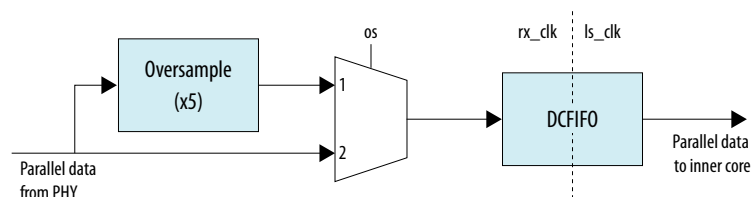

6.1.16. I2C Slave

The core includes a pair of I²C slaves when you turn on the **Include I2C** parameter.

- One slave is for the EDID address (0x50).
You need to instantiate a separate memory (ROM/RAM) to interface with this slave. The HDMI IP also has an optional feature to include a RAM for EDID.
- The other slave is for the SCDC address (0x54).
The I2C slave for the SCDC will be directly interfaced with the HDMI core for the SCDC registers operation.

6.1.17. I2C and EDID RAM Blocks

The HDMI IP includes a RAM to store your EDID information for the sink.

You need to specify your EDID content in a `.mif` or `.hex` file before you start generating the IP. You can also modify your EDID contents at run time.

The `edid_ram_access` signal acts as a trigger to the EDID RAM. When this signal is asserted, the IP holds the `hpd` signal low. During this period, you are free to modify the RAM content by accessing its Avalon memory-mapped interface through an Avalon memory-mapped master, such as NIOS.

After you are done modifying the RAM contents, deassert the `edid_ram_access` signal to reassert the `hpd` signal. The source device rereads the new EDID content.

Figure 54. Modifying EDID RAM

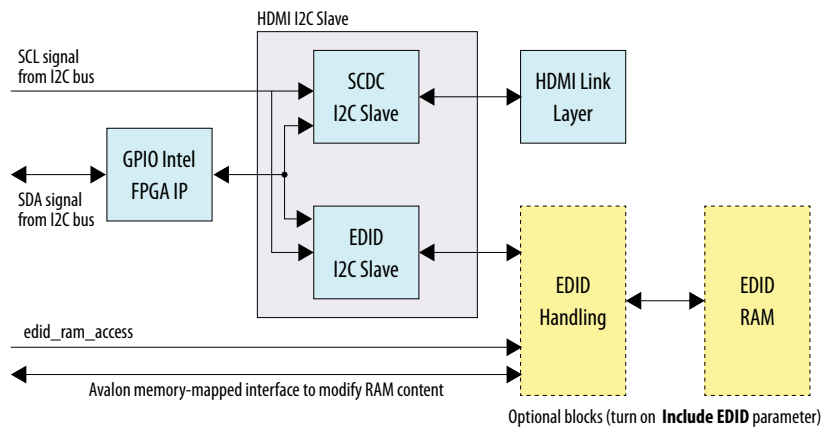

6.1.18. Variable Refresh Rate(VRR) and Auto Low Latency Mode (ALLM)

HDMI sink core is able to receive the video with variable refresh rate (VRR) transport. Since VRR involves runtime varying video vertical blanking, HDMI sink locked and `vid_lock` remains asserted when receiving video with VRR transport.

ALLM is enabled through the HF-VSI which can only be supported in sink auxiliary data port. You can capture the ALLM_Mode through the packet byte 5 bit 1 of HF-VSI through the sink auxiliary data port. Refer to HDMI 2.1 specification section 10.2 HDMI Forum Vendor Specific InfoFrame for more information.

6.2. Sink Interfaces

The table lists the port interfaces of the sink.

Table 59. Sink Interfaces

N is the number of pixels per clock.

| Interface | Port Type | Clock Domain | Port | Direction | Description |
|-----------|-----------|--------------|-----------|-----------|---|
| Reset | Reset | - | reset | Input | Main asynchronous reset input. <i>Note:</i> Asserting the reset input resets the SCDC register. |
| | Reset | - | reset_vid | | Reset input for the video domain. <i>Note:</i> This signal is only available when Support FRL = 0 . |
| Clock | Clock | - | ls_clk | Input | <p>Link speed clock input. This port is only used when Support FRL = 0.</p> <p>The out_c(3), out_r(2), out_g(1), and out_b(0) TMDS/FRL encoded data inputs run at this clock frequency.</p> <p>ls_clk frequency = data rate per lane/20</p> <p>This signal connects to the transceiver output clock only if TMDS Bit Rate is above the minimum transceiver data rate, which means no oversampling is required.</p> <p>This signal should connect to a PLL output clock that meets the vid_clk relationship if TMDS Bit Rate is below the minimum transceiver data rate, which means oversampling is required.</p> <p>In TMDS mode, data rate per lane is a function of pixel frequency and color depth ratio.</p> <p>Data rate per lane = Pixel frequency * 10 * Color depth ratio.</p> <ul style="list-style-type: none"> • 8 bpc: Color depth ratio = 1 • 10 bpc: Color depth ratio = 1.25 • 12 bpc: Color depth ratio = 1.5 • 16 bpc: Color depth ratio = 2 <p><i>Note:</i> The ls_clk signal is 3 bits wide for Intel Quartus Prime Pro Edition software versions 19.2 and earlier.</p> |

continued...

| Interface | Port Type | Clock Domain | Port | Direction | Description |
|-----------|-----------|--------------|---------|-----------|--|
| | | | | | Refer to Table 39 on page 89 for more details. |
| | Clock | - | vid_clk | Input | <p>Video data clock input.</p> <p>When Support FRL = 0, vid_clk frequency = data rate per lane/transceiver width/color depth ratio.</p> <ul style="list-style-type: none"> For RGB and YCbCr 4:4:4/4:2:2 transport: vid_clk frequency = (data rate per lane/transceiver width)/color depth ratio. For YCbCr 4:2:0 transport: vid_clk frequency = ((data rate per lane/transceiver width)/color depth ratio)/2. vid_clk needs to be synchronous to ls_clk. <p>When Support FRL = 1, vid_clk frequency = 225 MHz.</p> <ul style="list-style-type: none"> vid_clk runs at the maximum frequency across all resolutions and FRL rates. The video data is qualified by the vid_valid signal. vid_clk can be asynchronous to ls_clk and frl_clk. |
| | Clock | - | frl_clk | Input | <p>Clock supplied to the FRL path.</p> <p>FRL clock frequency = (data rate * number of lanes) / (FRL characters per clock * 18).</p> <p>frl_clk needs to be synchronous to clk_b.</p> <p><i>Note:</i> The number of lanes is always 4. For FRL rates 3, 4, 5, and 6, all 4 FRL lanes are used to transmit data. For FRL rates 1 and 2, only 3 FRL lanes are used to transmit data, and the 4th lane is unused.</p> |
| | Clock | - | clk_b | Input | Transceiver recovered clock from the "Blue" data channel. |

continued...

| Interface | Port Type | Clock Domain | Port | Direction | Description |
|-----------------|-----------|--------------|--------------------|-----------|--|
| | Clock | - | clk_g | Input | Transceiver recovered clock from the "Green" data channel. |
| | Clock | - | clk_r | Input | Transceiver recovered clock from the "Red" data channel. |
| | Clock | - | clk_c | Input | Transceiver recovered clock from the clock data channel. |
| | Clock | - | i2c_clk | Input | Avalon-MM SCDC Management Interface clock input. |
| Video Data Port | Conduit | vid_clk | vid_data[N*48-1:0] | Output | Video 48-bit pixel data output port. For N pixels per clock, this port produces N 48-bit pixels per clock. |
| | Conduit | vid_clk | vid_de[N-1:0] | Output | Video data enable output that indicates active picture region. |
| | Conduit | vid_clk | vid_hsync[N-1:0] | Output | Video horizontal sync output. |
| | Conduit | vid_clk | vid_vsync[N-1:0] | Output | Video vertical sync output. |
| | Conduit | vid_clk | vid_valid | Output | Indicates if the video data is valid. When in TMDS mode and vid_clk is running at the actual pixel clock, this signal should always be asserted. When you generate the video data at a frequency higher than the actual pixel clock, use vid_valid to qualify the validity of the video data. vid_valid and vid_clk guarantee the exact pixel clock rate. |
| | Conduit | vid_clk | locked | Output | Indicates that the HDMI sink core is locked to the TMDS or FRL signals with successful lane deskew and word alignment. <i>Note:</i> The locked[2:0] signal is 3 bits wide for Intel Quartus Prime Pro Edition software versions 19.2 and earlier, where each bit represents the locked status of a TMDS color channel. |

continued...

| Interface | Port Type | Clock Domain | Port | Direction | Description |
|-----------------------------------|-----------|--|-----------------------------|-----------|--|
| | Conduit | vid_clk | vid_lock | Output | Asserted when the length or duration of vid_de is consistent for 3 frames. If the length or duration of vid_de is inconsistent for 2 frames, this signal deasserts. |
| TMDS/FRL Data Port ⁽⁸⁾ | Conduit | Support FRL =1: clk_b Support FRL =0: ls_clk[0] | in_b[transceiver width-1:0] | Input | <p>TMDS encoded blue channel (0) input or FRL encoded channel 0.</p> <p>When in TMDS mode, this signal is TMDS encoded blue channel (0) output.</p> <p>When in FRL mode, this signal is FRL lane 0.</p> <ul style="list-style-type: none"> When Support FRL = 0, transceiver width is configured to 20 bits. When Support FRL = 1, transceiver width is configured to 40 bits. <p><i>Note:</i> For TMDS mode, only the 20 bits from the least significant bits are used. For FRL mode, all 40 bits are used.</p> |
| | Conduit | Support FRL =1: clk_b Support FRL =0: ls_clk[0] | in_g[transceiver width-1:0] | Input | <p>TMDS encoded green channel (1) input or FRL encoded channel 1.</p> <p>When in TMDS mode, this signal is TMDS encoded green channel (1) output.</p> <p>When in FRL mode, this signal is FRL lane 1.</p> <ul style="list-style-type: none"> When Support FRL = 0, transceiver width is configured to 20 bits. When Support FRL = 1, transceiver width is configured to 40 bits. <p><i>Note:</i> For TMDS mode, only the 20 bits from the least significant bits are used. For FRL mode, all 40 bits are used.</p> |
| | Conduit | Support FRL =1: clk_b | in_r[transceiver width-1:0] | Input | <p>TMDS encoded red channel (2) input or FRL encoded channel 2.</p> |

continued...

⁽⁸⁾ Connect to the transceiver data output if no oversampling is required. If oversampling is required, the port should connect to a DCFIFO and an oversampling user logic before connecting to a transceiver data output. Refer to [Sink Clock Tree](#) on page 133 for more information.

| Interface | Port Type | Clock Domain | Port | Direction | Description | |
|---------------------|--------------|--|-----------------------------|-----------|---|----------------------|
| | | Support FRL =0: ls_clk[0] | | | <p>When in TMDS mode, this signal is TMDS encoded red channel (2) output. When in FRL mode, this signal is FRL lane 2.</p> <ul style="list-style-type: none"> When Support FRL = 0, transceiver width is configured to 20 bits. When Support FRL = 1, transceiver width is configured to 40 bits. <p><i>Note:</i> For TMDS mode, only the 20 bits from the least significant bits are used. For FRL mode, all 40 bits are used.</p> | |
| | Conduit | clk_c | in_c[transceiver width-1:0] | Input | <p>When in TMDS mode, this signal is unused. When in FRL mode, this signal is FRL lane 3. When Support FRL = 1, transceiver width is configured to 40 bits</p> | |
| | Conduit | Support FRL =1: clk_b Support FRL =0: ls_clk[0] | in_lock | Input | <p>Indicates the HDMI RX core is ready to operate. This signal should be driven by the ready signal from the transceiver reset controller that indicates transceiver are locked.</p> <p><i>Note:</i> The in_lock signal is 3 bits wide for Intel Quartus Prime Pro Edition software versions 19.2 and earlier.</p> | |
| Decoder Status Port | Conduit | Support FRL =1: clk_b Support FRL =0: ls_clk[0] | ctrl[N*6-1:0] | Output | DVI (mode = 0) status signals that overwrite the control and synchronization character in the green and red channels. | |
| | | | | | Bit-Field | n=0,1.....N-1 |
| | | | | | n*6+5 | CTL3 |
| | | | | | n*6+4 | CTL2 |
| | | | | | n*6+3 | CTL1 |
| | | | | | n*6+2 | CTL0 |
| | | | | | n*6+1 | Reserved (0) |
| n*6 | Reserved (0) | | | | | |
| <i>continued...</i> | | | | | | |

| Interface | Port Type | Clock Domain | Port | Direction | Description |
|---------------------------------------|-----------|--|--------------------------|-----------|--|
| | | | | | Refer to the <i>HDMI 1.4b Specification</i> for more information. |
| | Conduit | Support FRL =1: clk_b Support FRL =0: ls_clk[0] | mode | Output | Indicates the encoding mode of the incoming TMDS signals. <ul style="list-style-type: none"> 0: DVI 1: HDMI <i>Note:</i> This signal is unused in FRL mode. |
| Link Training Control and Status Port | Conduit | i2c_clk | scdc_frl_ffe_levels[3:0] | Input | Indicates the maximum TxFFE level supported by the source at current FRL rate, These bits correspond to the SCDC sink configuration register 0x31 bits 4-7. |
| | Conduit | i2c_clk | scdc_frl_rate[3:0] | Output | Indicates the FRL rate (link rate and number of lanes) that the RX core is running. <ul style="list-style-type: none"> 0: Disable FRL 1: Fixed rate link at 3 Gbps per lane on 3 lanes 2: Fixed rate link at 6 Gbps per lane on 3 lanes 3: Fixed rate link at 6 Gbps per lane on 4 lanes 4: Fixed rate link at 8 Gbps per lane on 4 lanes 5: Fixed rate link at 10 Gbps per lane on 4 lanes 6: Fixed rate link at 12 Gbps per lane on 4 lanes |
| | Conduit | i2c_clk | scdc_frl_locked[3:0] | Output | Each bit indicates the corresponding FRL lane achieving lock. <ul style="list-style-type: none"> For 3-lane mode, the RX core asserts the lock bit when it detects SR or SSB followed by 680 FRL Character Periods, repeating for 3 times. Bit 3 is never asserted at 3-lane mode. For 4-lane mode, the RX core asserts the lock bit when it detects SR or SSB followed by 510 Character Periods, repeating for 3 times. |

continued...

| Interface | Port Type | Clock Domain | Port | Direction | Description |
|-----------|-----------|--------------|-------------------------------|-----------|--|
| | Conduit | i2c_clk | scdc_frl_ltp_req[15:0] | Input | <p>Write to the SCDC status flags 0x41 and 0x42 to request the source to transmit specific link training pattern. Set scdc_frl_ltp_req[15:0] 0x0000 to pass the link training process.</p> <ul style="list-style-type: none"> • Bit [15:12]: Link training pattern for lane 3 (SCDC status flag 0x42 bit[7:4]) • Bit [11:8]: Link training pattern for lane 2 (SCDC status flag 0x42 bit[3:0]) • Bit [7:4]: Link training pattern for lane 1 (SCDC status flag 0x41 bit[7:4]) • Bit [3:0]: Link training pattern for lane 0 (SCDC status flag 0x41 bit[3:0]) • By default this port is disabled. Sink will always request link training pattern 0x5678. To enable other link training pattern please contact Sale. • Sink does not support FFE. Pattern 0xEEEE are not supported. • Sink link training process will not automatically change to other FRL rate. Pattern 0xFFFF are not supported. |
| | Conduit | i2c_clk | scdc_frlflt_ready | Input | <p>Set this bit to 1 when the HDMI RX core is ready for the link training process. When asserted, the FLT_Ready bit in the SCDC status flag 0x40 bit 6 is set to 1, the FRL start flag is cleared, and the FLT update flag is set for the link training process.</p> |
| | Conduit | i2c_clk | scdc_frl_src_test_config[7:0] | Input | <p>Configure the Source Test Configuration register (SCDC register 0x35)</p> <ul style="list-style-type: none"> • Bit 7 : FRL_Max • Bit 6: SDC_FRL_Max • Bit 5: FLT_no_timeout • Bit 4: Reserved • Bit 3: TxFFE_No_FFE |

continued...

| Interface | Port Type | Clock Domain | Port | Direction | Description |
|--|-----------|--------------|----------------------|-----------|---|
| | | | | | <ul style="list-style-type: none"> Bit 2: TxFFE_De_Emphasis_only Bit 1: TxFFE_Pre_Shoot_Only Bit 0: Reserved For more information about these bits, refer to the 10.4.1.6.1 Source Test Configuration Request section of the HDMI 2.1 Specifications. |
| SCDC Control Port | Conduit | i2c_clk | in_5v_power | Input | Detects the presence of 5V input voltage. |
| | Conduit | i2c_clk | rx_hpd_req | Output | Indicates the Hot Plug Detect (HPD) status. This signal should be driven to the HPD pin on the HDMI connector. <ul style="list-style-type: none"> Sink will deassert rx_hpd_req if in_5v_power is low or after reset. Sink will assert rx_hpd_req after 1 second in_5v_power is detected, or after reset Contact sale team if want to change the HPD duration. |
| | Conduit | i2c_clk | TMDS_Bit_clock_Ratio | Output | Indicates if the TMDS Bit Rate is greater than 3.4 Gbps <ul style="list-style-type: none"> 0: (TMDS Bit Rate) / (TMDS Clock Rate) ratio is 10 or FRL mode 1: (TMDS Bit Rate) / (TMDS Clock Rate) ratio is 40 |
| Avalon-MM SCDC Management Interface ⁽⁹⁾ | Avalon-MM | i2c_clk | scdc_i2c_addr[7:0] | Input | Address. |
| | Avalon-MM | i2c_clk | scdc_i2c_r | Input | Assert to indicate a read transfer. |
| | Avalon-MM | i2c_clk | scdc_i2c_rdata[7:0] | Output | Data driven from the core in response to a read transfer. |
| | Avalon-MM | i2c_clk | scdc_i2c_w | Input | Assert to indicate a write transfer. |
| | Avalon-MM | i2c_clk | scdc_i2c_wdata[7:0] | Input | Data for write transfers. |
| continued... | | | | | |

⁽⁹⁾ Refer to *HDMI 2.0b Specification Section 10.4* for address and data bit mapping.

| Interface | Port Type | Clock Domain | Port | Direction | Description |
|---|-----------|--------------|--|-----------|--|
| Auxiliary Data Port (Applicable only when you enable Support auxiliary parameter) | Conduit | aux_clk | aux_valid | Output | Auxiliary data channel valid output to qualify the data. |
| | Conduit | aux_clk | aux_data[71:0] | Output | Auxiliary data channel data output. For information about the bit-fields, refer to Figure 48 on page 99. |
| | Conduit | aux_clk | aux_sop | Output | Auxiliary data channel start-of-packet output to mark the beginning of a packet. |
| | Conduit | aux_clk | aux_eop | Output | Auxiliary data channel end-of-packet output to mark the end of a packet. |
| | Conduit | aux_clk | aux_error | Output | Asserted when there is auxiliary data channel CRC error. |
| Auxiliary Status Port (Applicable only when you enable Support auxiliary parameter) ⁽¹⁰⁾ | Conduit | aux_clk | gcp[5:0] | Output | General Control Packet output. For information about the bit-fields, refer to Table 22 on page 50. |
| | Conduit | aux_clk | info_avi[122:0] (Support FRL = 1) info_avi[111:0] (Support FRL = 0) | Output | Auxiliary Video Information InfoFrame output. For information about the bit-fields, refer to Table 23 on page 50. |
| | Conduit | aux_clk | info_vsi[60:0] | Output | Vendor Specific Information InfoFrame output. For information about the bit-fields, refer to Table 25 on page 52. |
| Auxiliary Memory Interface (Applicable only when you enable Support auxiliary parameter) ⁽¹⁰⁾ | Conduit | aux_clk | aux_pkt_addr[6:0] | Output | Auxiliary packet memory buffer address output. |
| | Conduit | aux_clk | aux_pkt_data[71:0] | Output | Auxiliary packet memory buffer data output. |
| | Conduit | aux_clk | aux_pkt_wr | Output | Auxiliary packet memory buffer write strobe output. |
| Audio Port (Applicable only when you enable Support auxiliary and Support audio parameters) ⁽¹⁰⁾ | Conduit | aux_clk | audio_CTS[19:0] | Output | Audio CTS value output. |
| | Conduit | aux_clk | audio_N[19:0] | Output | Audio N value output. |
| | Conduit | aux_clk | audio_data[255:0] | Output | Audio data output. For audio channel values, refer to Table 38 on page 84. |

continued...

⁽¹⁰⁾ aux_clk = ls_clk (**Support FRL = 0**)
aux_clk = vid_clk (**Support FRL = 1**)

| Interface | Port Type | Clock Domain | Port | Direction | Description | |
|---------------------------------------|---|--|------------------------|---|--|--|
| | Conduit | aux_clk | audio_de | Output | Audio data valid output. | |
| | Conduit | aux_clk | audio_metadata[164:0] | Output | Additional information related to 3D audio and MST audio. For information about the bit-fields, refer to Table 28 on page 57, Table 29 on page 57, and Table 30 on page 57. | |
| | Conduit | aux_clk | audio_format[4:0] | Output | Indicates 3D audio status and the audio format detected. | |
| | | | | | Bit-Field | Description |
| | | | | | 4 | The core asserts to indicate the first 8 channels of each 3D audio sample. |
| 3:0 | For information about the bit-fields, refer to Table 26 on page 54. | | | | | |
| Conduit | aux_clk | audio_info_ai[47:0] | Output | Audio InfoFrame output bundle. For information about the bit-fields, refer to Table 27 on page 56. | | |
| PHY Control Interface Port | Conduit | Support FRL:clk_b Support FRL =0:ls_clk | os | Input | Indicates to the core that the current receiving data rate requires downsampling with a factor of 5. Assert this signal when the receiving TMDS Bit Rates is less than 1 Gbps. | |
| I ² C Slave Interface Port | Conduit | - | i2c_scl | Input | SCL signal from I ² C bus on the HDMI connector. This signal is not available if you turn off the Include I2C parameter. | |
| | Conduit | - | i2c_sda | Inout | SDA signal from I ² C bus on the HDMI connector. This signal is not available if you turn off the Include I2C parameter. | |
| | | i2c_clk | edid_i2cslv_rdata[7:0] | Input | Connect this signal to the output q port of an EDID RAM. This signal returns | |

continued...

| Interface | Port Type | Clock Domain | Port | Direction | Description |
|-----------------------------|-----------|-------------------------|------------------------|-----------|--|
| | | | | | the value from a certain address in the RAM to the internal I ² C slave. This signal is available only if you turn on the Include I2C parameter and turn off the Include EDID RAM parameter. |
| | Conduit | i2c_clk | edid_i2cslv_addr[31:0] | Output | Connect this signal to the output address port of an EDID RAM. This signal indicates the address that the I ² C slave would access to the RAM. This signal is available only if you turn on the Include I2C slave parameter and turn off the Include EDID RAM parameter. |
| | Conduit | i2c_clk | tmds_config_trans_de t | Output | Indicates that there is a new write operation to the SCDC address offset 0x20 (TMDS configuration). Connect this signal to a reconfiguration controller to restart the reconfiguration flow. This signal is not available if you turn off the Include I2C parameter. |
| EDID RAM Interface Port | Conduit | i2c_clk | edid_ram_access | Input | Assert this signal when you are reading or writing to the EDID RAM. Deassert this signal when the read and write operations are complete. Asserting this signal would trigger an HPD event to the source. When you deassert this signal, the source reads the new EDID which you have just written into the RAM. This signal is not available if you turn off the Include EDID RAM parameter. |
| | Avalon-MM | i2c_clk | edid_ram_address | Input | Avalon memory mapped interface to the EDID RAM. Connect these signals to an Avalon memory mapped master, such as NIOS, to perform read and write operation to the EDID RAM. |
| | Avalon-MM | i2c_clk | edid_ram_read | Input | |
| | Avalon-MM | i2c_clk | edid_ram_write | Input | |
| | Avalon-MM | i2c_clk | edid_ram_waitrequest | Output | These signals are not available if you turn off the Include EDID RAM parameter. |
| | Avalon-MM | i2c_clk | edid_ram_readdata[7:0] | Output | |
| Avalon-MM | i2c_clk | edid_ram_writedata[7:0] | Input | | |
| HDCP Port (Applicable only) | Reset | - | hdcp_reset | Input | Main asynchronous reset. |

continued...

| Interface | Port Type | Clock Domain | Port | Direction | Description |
|--|-----------|--------------|--------------------|-----------|--|
| when you enable Support HDCP 2.3 or Support HDCP 1.4 parameters) | Clock | - | hdcp_i2c_clk | Input | HDCP clock for control and status registers. Typically, shares the I ² C slave clock (100 MHz). |
| | | - | crypto_clk | Input | HDCP 2.3 clock for authentication and cryptographic layer. You can use any clock with a frequency up to 200 MHz. Not applicable for HDCP 1.4. <i>Note:</i> The clock frequency determines the authentication latency. |
| | | - | rpt_msg_clk | Input | HDCP clock for the Repeater registers in the Control and Status Register layer. Typically, shares the clock (100 MHz) that drives the repeater downstream Nios II processor. Available only when you turn on the SUPPORT_REPEATER parameter. |
| | Avalon-MM | hdcp_i2c_clk | hdcp_i2c_addr[7:0] | Input | The Avalon-MM slave port that provides access to HDCP registers. The I2C slave must drive this port for HDMI application. |
| | | | hdcp_i2c_wr | Input | |
| | | | hdcp_i2c_rd | Input | |
| | | | hdcp_i2c_wrd[7:0] | Input | |
| | | | hdcp_i2c_rdd[7:0] | Output | |
| | Conduit | hdcp_i2c_clk | i2c_stop_det | Input | Assert this signal to indicate the stop condition for each I2C command. |
| | Avalon-MM | rpt_msg_clk | rpt_msg_addr[7:0] | Input | The Avalon-MM slave port that provides access to the Repeater registers, mainly for Receiver ID List and RxInfo. This interface is expected to operate at repeater downstream Nios II processor clock domain. Because of the extremely large bit portion of message, the IP transfers the message in burst mode with full handshaking mechanism. Write transfers always have a wait time of 0 cycle while read transfers have a wait time of 1 cycle. |
| | | | rpt_msg_wr | Input | |
| | | | rpt_msg_rd | Input | |
| | | | rpt_msg_wrd[31:0] | Input | |
| | | | rpt_msg_rdd[31:0] | Output | |

continued...

| Interface | Port Type | Clock Domain | Port | Direction | Description |
|---|---------------|---------------------------------|-----------|---|---|
| | | | | | The addressing should be accessed as word addressing in the Platform Designer flow. For example, addressing of 4 in the Nios II software selects the address of 1 in the slave. |
| | Conduit (Key) | crypto_clk | kmem_wait | Input | Always keep this signal asserted until the key is ready to be read. This signal is not available if you turn on the Support HDCP Key Management parameter. |
| kmem_rdaddr[7:0] (HDCP 2.3) kmem_rdaddr[13:8] (HDCP 1.4) | | | Output | Key read address bus. This signal is not available if you turn on the Support HDCP Key Management parameter. | |
| kmem_q[31:0] (HDCP 2.3) kmem_q[87:32] (HDCP 1.4) | | | Input | 32-bit (HDCP 2.3) or 56-bit (HDCP 1.4) data for read transfers. Read transfer always have a wait time of 1 cycle. This signal is not available if you turn on the Support HDCP Key Management parameter. | |
| Avalon-MM | hdcpi2c_clk | hdcpi1_kmem_wr | Input | The Avalon-MM slave port provides write access to internal HDCP 1.4 key storage. Write transfers always have a wait time of 0. The Avalon memory-mapped master access the addressing as word addressing in the Platform Designer flow. For example, addressing of 4 in the Avalon memory-mapped master selects the address of 1 in the slave. These signals are only available if you turn on the Support HDCP Key Management parameter and the Support HDCP 1.4 parameter | |
| | | hdcpi1_kmem_wrd[31:0] | Input | | |
| | | hdcpi1_kmem_addr[6:0] | Input | | |
| Avalon-MM | hdcpi2c_clk | hdcpi2_kmem_wr | Input | The Avalon memory-mapped slave port that provides write access to internal HDCP 2.3 key storage. Write transfers always have a wait time of 0. | |
| | | hdcpi2_kmem_wrd[31:0] Avalon | Input | | |
| | | hdcpi2_kmem_addr[7:0] | Input | | |

continued...

| Interface | Port Type | Clock Domain | Port | Direction | Description |
|-----------|-----------|--------------|---------------|-----------|--|
| | | | | | The Avalon memory-mapped master access the addressing as word addressing in the Platform Designer flow. For example, addressing of 4 in the Avalon memory-mapped master selects the address of 1 in the slave. These signals are only available if you turn on the Support HDCP Key Management parameter and the Support HDCP 2.3 parameter. |
| | Conduit | ls_clk | hdcpl_enabled | Output | This signal is asserted by the IP if the incoming video and auxiliary data are HDCP 1.4 encrypted. |
| | | | hdcp2_enabled | Output | This signal is asserted by the IP if the incoming video and auxiliary data are HDCP 2.3 encrypted. |
| | | | streamid_type | Output | <ul style="list-style-type: none"> 0: The received stream type is 0. 1: The received stream type is 1. |
| | | hdcpi2c_clk | hdcpl_disable | Input | Assert this signal to disable the HDCP 1.4 IP. <i>Note:</i> You must reset the HDCP IP (<code>hdcp_reset</code>) and trigger a Hot Plug event after toggling this signal. |
| | | | hdcp2_disable | Input | Assert this signal to disable the HDCP 2.3 IP. <i>Note:</i> You must reset the HDCP IP (<code>hdcp_reset</code>) and trigger a Hot Plug event after toggling this signal. |

6.3. Sink Clock Tree

The sink core uses various clocks.

The logic clocks the transceiver data into the core using the three CDR clocks: (`rx_clk[2:0]`).

The TMDS and TERC4 decoding is done at the link-speed clock (`ls_clk`) or transceiver recovered clock when you turn on the **Support FRL** parameter. The sink then resamples the pixel data and presents the data at the output of the core at the video pixel clock (`vid_clk`).

The pixel data clock depends on the video format used (within HDMI specification).

Figure 55. Sink Clock Tree

The figure shows how the different clocks connect in the sink core.

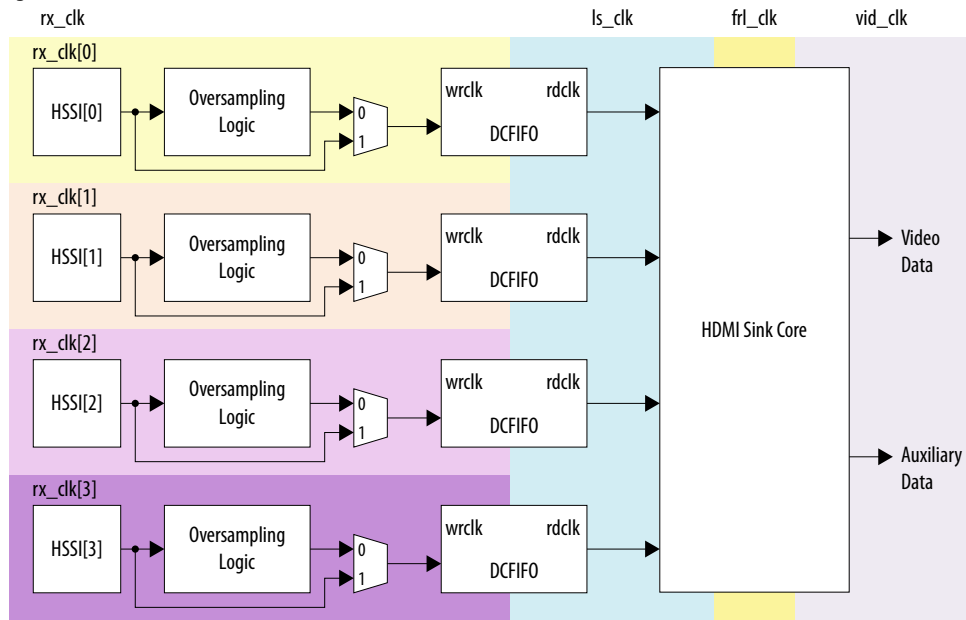

For HDMI sink, you must instantiate three receiver channels to receive data in TMDS mode or four receiver channels to receive data in FRL mode.

Figure 56. Sink Clock Tree when Support FRL = 1

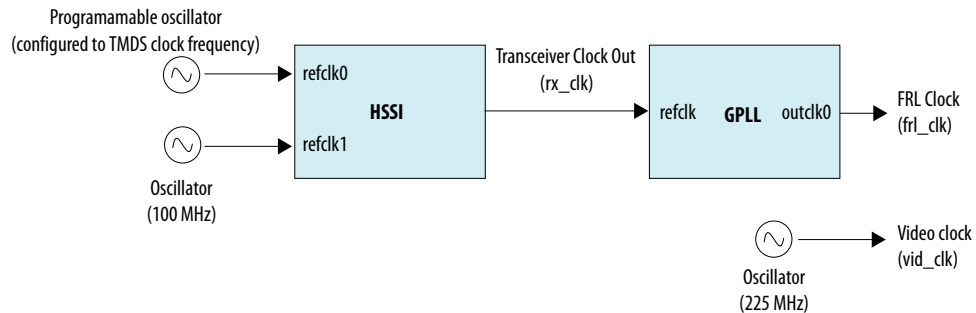

When Support FRL = 1, the transceiver RX CDR has two reference clocks:

- Reference clock 0, which is supplied with TMDS clock from the HDMI connector.
- Reference clock 1 supplied with free running 100 MHz clock for FRL mode.

This RX CDR switches between reference clock 0 and reference clock 1 based on TMDS or FRL mode.

A general-purpose phase-locked loop GPLL that is referenced by the transceiver output clock, is used to generate the FRL (*frl_clk*) clock. You can fix *vid_clk* at a static frequency of 225 MHz. For Support FRL =1 design, *ls_clk* is not required.

Figure 57. Sink Clock Tree when Support FRL = 0

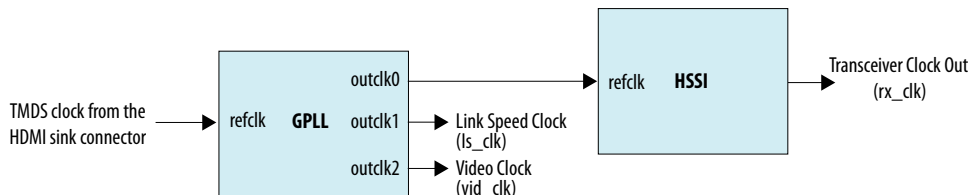

When Support FRL = 0, a general purpose phase-locked loop GPLL that is referenced by the TMDS clock from the HDMI sink connector, is used to generate reference clock to the transceiver RX CDR, the link speed clock (`ls_clk`) and video clock (`vid_clk`) for the core. This GPLL switches between reference clock 0 and reference clock 1 based on TMDS or FRL mode.

- For **Support FRL = 0** design, `fml_clk` is not required.

Note: GPLL refers to IOPLL Intel FPGA IP for Intel Arria 10, Intel Cyclone 10 GX, and Intel Stratix 10 devices; PLL Intel FPGA IP for Arria V and Stratix V devices.

- The TMDS/FRL data clocks into the core at `ls_clk` (Support FRL = 0) or transceiver recovered clock (Support FRL = 1) with all channels driven by the same clock source (GPLL CLK1).
- The video data clocks out from the core at `vid_clk`.

`ls_clk`, and `vid_clk` are derived based on the color depth, TMDS Bit clock ratio, user oversampling control bit information, and the detected Clock Channel frequency band in TMDS mode (**Support FRL = 0**).

Related Information

- [HDMI Hardware Design Examples for Arria V and Stratix V Devices](#) on page 22
- [HDMI Hardware Design Examples for Intel Arria 10, Intel Cyclone 10 GX, and Intel Stratix 10 Devices](#) on page 21

6.4. Link Training Procedure

The HDMI RX core includes a state machine for link training process.

Sink will always request link training pattern 0x5678. These link training patterns start with 4 Scrambler Reset (SR) characters followed by 4096 encoded and scrambled data. After receiving the SR characters, the HDMI RX core achieves alignment and lane deskew lock to qualify the received link training pattern.

After detecting the pattern, sink will set link training pattern 0x0000 indicating link training passed.

Figure 58. Sink Link Training State Machine Flow Diagram

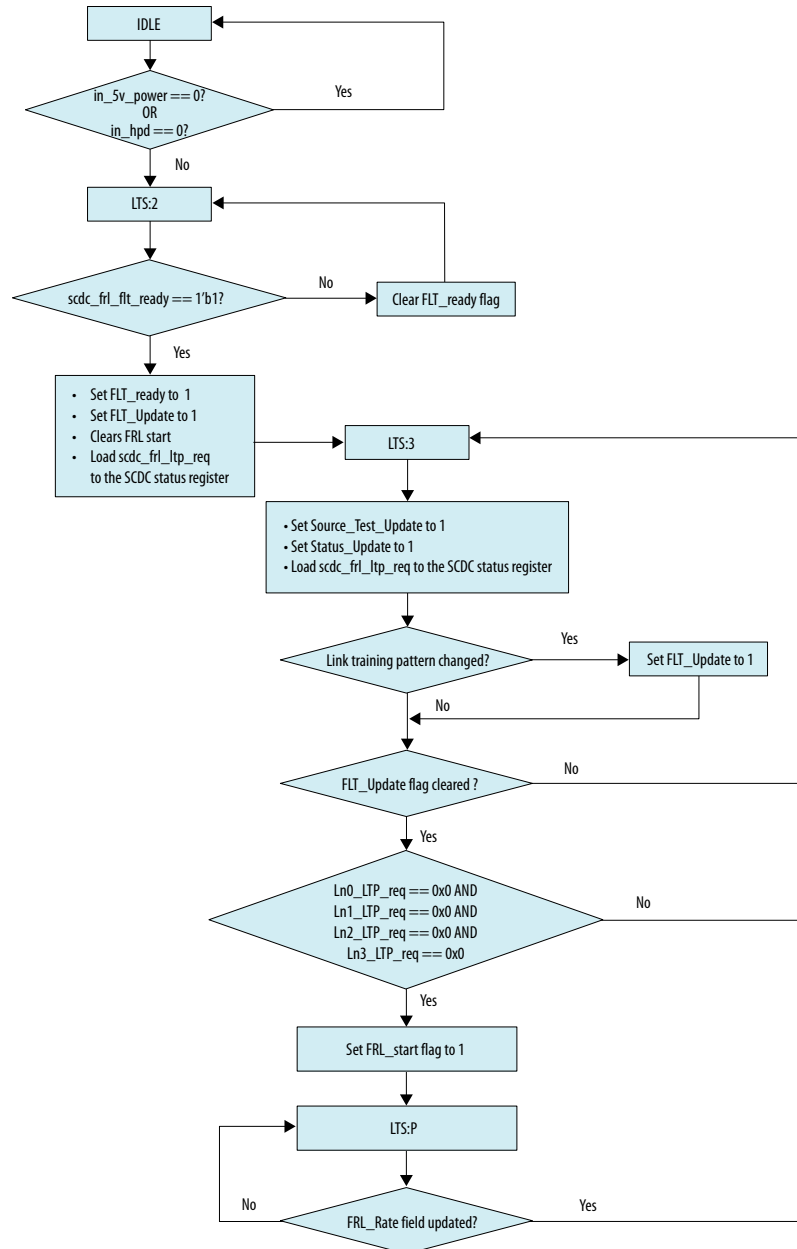

6.5. Sink Deep Color Implementation When Support FRL = 0

When **Support FRL** = 0, the HDMI RX core requires you to derive vid_clk from ls_clk based on the color depth ratio.

$$ls_clk \text{ frequency} = \text{data rate per lane} / \text{effective transceiver width}$$

$$vid_clk \text{ frequency} = (\text{data rate per lane} / \text{effective transceiver width}) / \text{color depth ratio}$$

Table 60. Color Depth Ratio for Bits per Color

| Bits per Color | Color Depth Ratio |
|----------------|-------------------|
| 8 | 1.0 |
| 10 | 1.25 |
| 12 | 1.5 |
| 16 | 2.0 |

Figure 59. Deep Color Implementation When FRL = 0

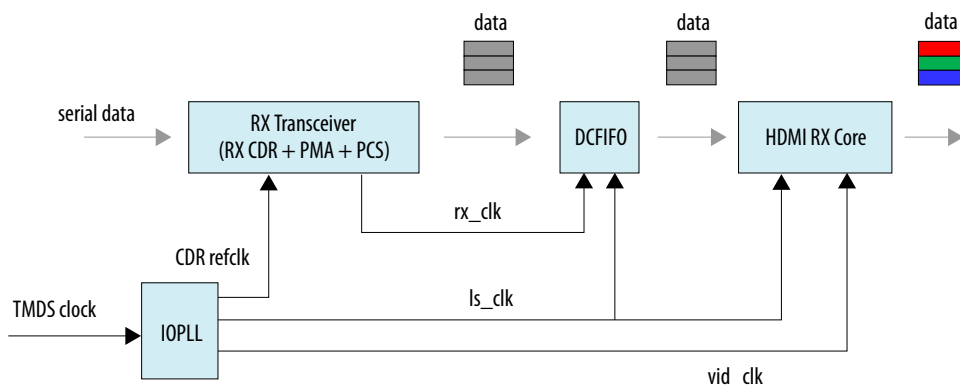

When **Support FRL = 0**, the RX core uses the TMD5 clock to drive the IOPLL reference clock. The IOPLL generates three output clocks that drive the CDR reference clock, `ls_clk`, and `vid_clk`.

When the HDMI RX core operates in `vid_clk` and `ls_clk` with the correct color depth ratio, the `vid_valid` signal is always high.

Figure 60. 10 Bits per Component (30 Bits per Pixel)

When operating in 10 bits per component, the `vid_clk` frequency to `ls_clk` frequency ratio is 4:5. For every 5 `ls_clk` cycles, there should be 4 `vid_clk` cycles.

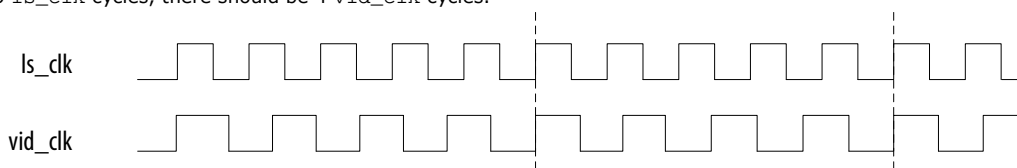

Figure 61. 12 Bits per Component (36 Bits per Pixel)

When operating in 12 bits per component, the `vid_clk` frequency to `ls_clk` frequency ratio is 2:3. For every 3 `ls_clk` cycles, there should be 2 `vid_clk` cycles.

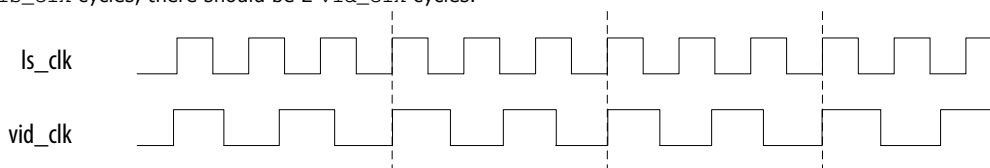
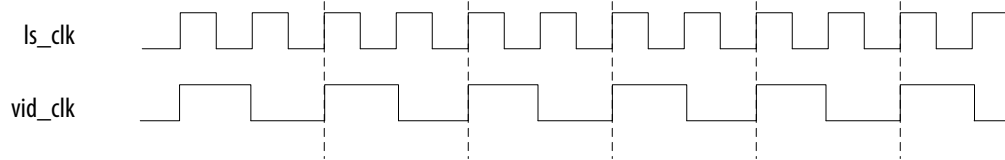

Figure 62. 16 Bits per Component (48 Bits per Pixel)

When operating in 16 bits per component, the `vid_clk` frequency to `ls_clk` frequency ratio is 1:2. For every 1 `ls_clk` cycle, there should be 2 `vid_clk` cycles.



6.6. Sink Deep Color Implementation When Support FRL = 1

When **Support FRL = 1**, you should drive `vid_clk` based on their frequency, regardless of the color depth ratio.

`vid_clk` frequency = 225 MHz

In deep color mode, the video data (30 bpp, 36 bpp, or 48 bpp) in the `vid_clk` domain has higher throughput than the data in the `ls_clk` domain. The HDMI RX core uses the `vid_valid` signal to indicate the validity of the video data at a specific clock.

Figure 63. Deep Color Implementation When Support FRL = 1

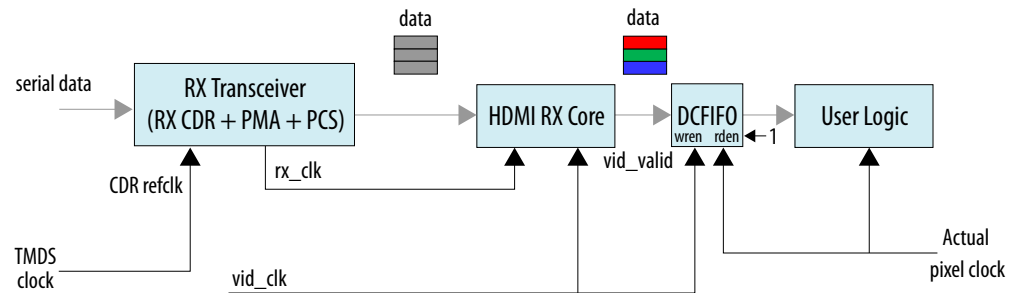

If your user logic cannot process the video data at a faster rate, you can use a DCFIFO to clock cross the video data from `vid_clk` to the actual pixel clock as shown in the diagram below. The `wren` signal of the DCFIFO IP connects to the `vid_valid` signal from the HDMI RX core. The `rden` signal is always asserted.

When operating in 10 bits per color, the `vid_ready` signal is high for 4 out of 5 clock cycles. For every 5 clock cycles, the HDMI RX core receives 4 valid video data with 10 bits per color.

The timing diagrams and description below assume that the video data at the `vid_clk` domain is running at the actual deep color data rate. If the video data at the `vid_clk` domain is running faster than the actual deep color data rate, the `vid_valid` signal would toggle more.

Figure 64. 10 Bits per Component (30 Bits per Pixel)

When operating in 10 bits per component, the `vid_valid` signal is high for 4 out of 5 clock cycles. For every 5 clock cycles, the HDMI RX core receives 4 valid video data with 10 bits per component.

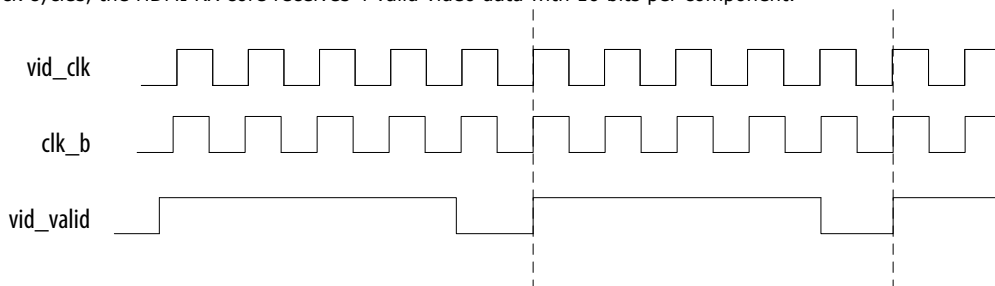

Figure 65. 12 Bits per Component (36 Bits per Pixel)

When operating in 12 bits per component, the `vid_valid` signal is high for 2 out of 3 clock cycles. For every 3 clock cycles, the HDMI RX core receives 2 valid video data with 12 bits per component.

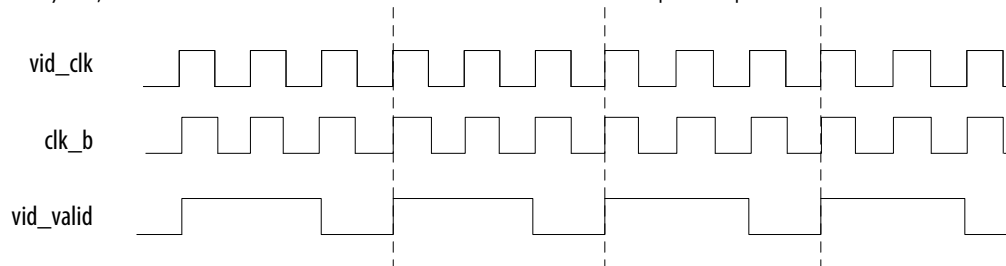
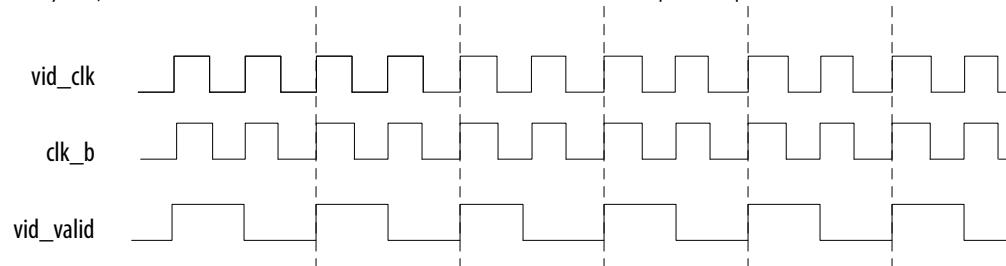

Figure 66. 16 Bits per Component (48 Bits per Pixel)

When operating in 16 bits per component, the `vid_valid` signal is high for 1 out of 2 clock cycles. For every 2 clock cycles, the HDMI RX core receives 1 video valid data with 16 bits per component.



7. HDMI Parameters

Use the settings in the HDMI parameter editor to configure your design.

7.1. HDMI Source Parameters

Table 61. HDMI Source Parameters

| Parameter | Value | Description |
|--------------------|---|---|
| Device family | Intel Stratix 10 Intel Arria 10 Intel Cyclone 10 GX Arria V Stratix V | Targeted device family. This parameter inherits the value from the project device. |
| Direction | Transmitter Receiver | Select HDMI transmitter. |
| Pixels per clock | 2 or 8 pixels per clock | Determines how many pixels are processed per clock. <ul style="list-style-type: none"> When you turn off Support FRL, supports 2 pixels per clock. When you turn on Support FRL, supports 8 pixels per clock. <i>Note:</i> This parameter is available only with Intel Arria 10 and Intel Stratix 10 devices. |
| Transceiver width | 20 or 40 bits | Determines the required transceiver width. The transceiver width depends on the number of TMDS symbols processed in parallel (symbols per clock). <ul style="list-style-type: none"> When you turn off Support FRL, transceiver width is 20 bits (2 symbols per clock). When you turn on Support FRL, transceiver width is 40 bits (4 symbols per clock). <i>Note:</i> This parameter is available only with Intel Arria 10 and Intel Stratix 10 devices. |
| Support auxiliary | On, Off | Determines if auxiliary channel encoding is included. This parameter is turned on by default. This parameter is always turned on when Support FRL is enabled. |
| Support deep color | On, Off | Determines if the core can encode deep color formats. This parameter is turned on by default. |
| Support audio | On, Off | Determines if the core can encode audio data. To enable this parameter, you must also enable the Support auxiliary parameter. This parameter is turned on by default. |
| Support FRL | On, Off | Turn on to enable the FRL path. |

continued...

| Parameter | Value | Description |
|-----------------------------|-------------------------------|--|
| | | When enabled, the clock domains for the auxiliary and audio ports, and the internal modules are different Refer to the block diagram for more details. <i>Note:</i> This parameter is available only with Intel Arria 10 and Intel Stratix 10 devices. |
| Support HDCP 2.3 | On, Off | Turn on to enable HDCP 2.3 TX support. This parameter can only be used with Intel Arria 10 and Intel Stratix 10 devices. <i>Note:</i> The HDCP-related parameters are not included in the Intel Quartus Prime Pro Edition software. To access the HDCP feature, contact Intel at https://www.intel.com/content/www/us/en/broadcast/products/programmable/applications/connectivity-solutions.html . |
| Support HDCP 1.4 | On, Off | Turn on to enable HDCP 1.4 TX support. This parameter can only be used with Intel Arria 10 and Intel Stratix 10 devices. <i>Note:</i> The HDCP-related parameters are not included in the Intel Quartus Prime Pro Edition software. To access the HDCP feature, contact Intel at https://www.intel.com/content/www/us/en/broadcast/products/programmable/applications/connectivity-solutions.html . |
| Support HDCP Key Management | On, Off | Turn on to enable HDCP key management support. You can only turn on this parameter if you turn on the Support HDCP 1.4 or Support HDCP 2.3 parameters. <i>Note:</i> 1. The HDCP-related parameters are not included in the Intel Quartus PrimeIntel Quartus Prime Pro EditionIntel Quartus Prime Pro Edition software. To access the HDCP feature, contact Intel at https://www.intel.com/content/www/us/en/broadcast/products/programmable/applications/connectivity-solutions.html . 2. The HDCP key management support from version 21.3 onwards is not compatible with the KEYENC version 21.2 and earlier. You need to re-encrypt the HDCP production keys using the KEYENC version 21.3 onwards. Refer to <i>HDMI Intel Arria 10 FPGA IP Design Example User Guide</i> and <i>HDMI Intel Stratix 10 FPGA IP Design Example User Guide</i> for more details. |
| Include I2C slave | On, Off | Turn on to include a pair of I ² C slaves for EDID and SCDC registers. path. |
| Include EDID RAM | On, Off | Turn on to include RAM to store EDID information for RX. You can only turn on this parameter if you turned on the Include I2C slave parameter. |
| EDID RAM size | In multiple of 2 ^N | Specifies the memory size in number of <i>N</i> -bit words. The value must be in multiple of 2 ^N . For example, the default memory size is 256 words which is 28 with <i>N</i> = 8. The <i>N</i> also determines the width of the address bus of the RAM's Avalon memory-mapped nterface. |

continued...

| Parameter | Value | Description |
|--------------------------|---------|---|
| | | This parameter is enabled only if you turned on the Include EDID RAM parameter. |
| RAM file path | - | Initial content of the memory. The file must be in .hex or .mif file type. This parameter is enabled only if you turned on the Include EDID RAM parameter. |
| HPD signal polarity | 0, 1 | Specifies the polarity of Hot Plug Detect (HPD) signal from the connector. <ul style="list-style-type: none"> 0: Negative 1: Positive <i>Note:</i> For Bitec daughter card, always set the polarity to 0. |
| Include I2C Master/Slave | On, Off | Turn on to include I2C master on the HDMI TX or I2C slave on the HDMI RX for the DDC channel communication. When enabled for RX, HDMI RX core includes I2C slave with I2C serial interface exposed for the connection to the HDMI connector. I2C slave is driven internally by EDID RAM and SCDC register. When enabled for TX, HDMI TX core includes I2C master with I2C serial interface exposed for the connection to the HDMI connector. I2C master will also expose Avalon-MM interface for the user control using NIOS. |

Related Information

- [HDMI Intel Arria 10 FPGA IP Design Example User Guide](#)
 For more information about the HDCP over HDMI design example for Intel Arria 10 devices and the security considerations when using the HDCP features.
- [HDMI Intel Stratix 10 FPGA IP Design Example User Guide](#)
 For more information about the HDCP over HDMI design example for Intel Stratix 10 devices and the security considerations when using the HDCP features.

7.2. HDMI Sink Parameters

Table 62. HDMI Sink Parameters

| Parameter | Value | Description |
|---------------------|---|---|
| Device family | Intel Stratix 10 Intel Arria 10 Intel Cyclone 10 GX Arria V Stratix V | Targeted device family. This parameter inherits the value from the project device. |
| Direction | Transmitter Receiver | Select HDMI receiver. |
| Pixels per clock | 2 or 8 pixels per clock | Determines how many pixels are processed per clock. <ul style="list-style-type: none"> When you turn off Support FRL, supports 2 pixels per clock. When you turn on Support FRL, supports 8 pixels per clock. |
| <i>continued...</i> | | |

| Parameter | Value | Description |
|-----------------------------|---------------|---|
| | | <i>Note:</i> This parameter is available only with Intel Arria 10 and Intel Stratix 10 devices. |
| Transceiver width | 20 or 40 bits | Determines the required transceiver width. The transceiver width depends on the number of TMDS symbols processed in parallel (symbols per clock). <ul style="list-style-type: none"> When you turn off Support FRL, transceiver width is 20 bits (2 symbols per clock). When you turn on Support FRL, transceiver width is 40 bits (4 symbols per clock). <i>Note:</i> This parameter is available only with Intel Arria 10 and Intel Stratix 10 devices. |
| Support auxiliary | On, Off | Determines if auxiliary channel encoding is included. This parameter is turned on by default. This parameter is always turned on when Support FRL is enabled. |
| Support deep color | On, Off | Determines if the core can encode deep color formats. This parameter is turned on by default. |
| Support audio | On, Off | Determines if the core can encode audio data. To enable this parameter, you must also enable the Support auxiliary parameter. This parameter is turned on by default. |
| Support FRL | On, Off | Turn on to enable the FRL path. When enabled, the clock domains for the auxiliary and audio ports, and the internal modules are different. Refer to the block diagram for more details. <i>Note:</i> This parameter is available only with Intel Arria 10 and Intel Stratix 10 devices. |
| Support HDCP 1.4 | On, Off | Turn on to enable HDCP 1.4 RX support. This parameter can only be used with Intel Arria 10 and Intel Stratix 10 devices. <i>Note:</i> The HDCP-related parameters are not included in the Intel Quartus Prime Pro Edition software. To access the HDCP feature, contact Intel at https://www.intel.com/content/www/us/en/broadcast/products/programmable/applications/connectivity-solutions.html . |
| Support HDCP 2.3 | On, Off | Turn on to enable HDCP 2.3 RX support. This parameter can only be used with Intel Arria 10 and Intel Stratix 10 devices. <i>Note:</i> The HDCP-related parameters are not included in the Intel Quartus Prime Pro Edition software. To access the HDCP feature, contact Intel at https://www.intel.com/content/www/us/en/broadcast/products/programmable/applications/connectivity-solutions.html . |
| Support HDCP Key Management | On, Off | Turn on to enable HDCP key management support. You can only turn on this parameter if you turn on the Support HDCP 1.4 or Support HDCP 2.3 parameters. |

continued...

| Parameter | Value | Description |
|-------------------|-------------------------------|--|
| | | <p><i>Note:</i> 1. The HDCP-related parameters are not included in the Intel Quartus Prime Pro Edition software. To access the HDCP feature, contact Intel at https://www.intel.com/content/www/us/en/broadcast/products/programmable/applications/connectivity-solutions.html.</p> <p>2. The HDCP key management support from version 21.3 onwards is not compatible with the KEYENC version 21.2 and earlier. You need to re-encrypt the HDCP production keys using the KEYENC version 21.3 onwards. Refer to <i>HDMI Intel Arria 10 FPGA IP Design Example User Guide</i> and <i>HDMI Intel Stratix 10 FPGA IP Design Example User Guide</i> for more details.</p> |
| Manufacturer OUI | — | <p>The Manufacturer Organizationally Unique Identifier (OUI) assigned to the manufactured device to be written into the SCDC registers of address 0xD0, 0xD1, and 0xD2.</p> <p>Key in 3 byte hexadecimal data.</p> |
| Device ID String | — | <p>The Device Identification (ID) string to be written into the SCDC registers from addresses 0xD3 to 0xDa.</p> <p>Use this parameter to identify the sink device. You can key in up to eight ASCII characters. If you use less than eight characters, the unused bytes are set to 0x00.</p> |
| Hardware Revision | — | <p>Indicates the major and minor revisions of the hardware. Key in one byte of integer data.</p> <ul style="list-style-type: none"> Upper byte represents major revision. Lower byte represents minor revision. <p>The hardware major revision increments on a major silicon or board revision. The hardware minor revision increments on a minor silicon revision or minor board revision and resets to 0 when the major revision increments.</p> |
| Include I2C slave | On, Off | <p>Turn on to include a pair of I²C slaves for EDID and SCDC registers. path.</p> |
| Include EDID RAM | On, Off | <p>Turn on to include RAM to store EDID information for RX.</p> <p><i>Note:</i> You can only turn on this parameter if you turned on the Include I2C slave parameter.</p> |
| EDID RAM size | In multiple of 2 ^N | <p>Specifies the memory size in number of <i>N</i>-bit words. The value must be in multiple of 2^N. For example, the default memory size is 256 words which is 28 with <i>N</i> = 8.</p> <p>The <i>N</i> also determines the width of the address bus of the RAM's Avalon memory-mapped interface.</p> <p><i>Note:</i> This parameter is enabled only if you turned on the Include EDID RAM parameter.</p> |
| RAM file path | - | <p>Initial content of the memory. The file must be in .hex or .mif file type.</p> |

continued...

| Parameter | Value | Description |
|--------------------------|---------|---|
| | | <i>Note:</i> This parameter is enabled only if you turned on the Include EDID RAM parameter. |
| HPD signal polarity | 0, 1 | Specifies the polarity of Hot Plug Detect (HPD) signal from the connector. <ul style="list-style-type: none"> • 0: Negative • 1: Positive <i>Note:</i> For Bitec daughter card, always set the polarity to 0. |
| Include I2C Master/Slave | On, Off | Turn on to include I2C master on the HDMI TX or I2C slave on the HDMI RX for the DDC channel communication. When enabled for RX, HDMI RX core includes I2C slave with I2C serial interface exposed for the connection to the HDMI connector. I2C slave is driven internally by EDID RAM and SCDC register. When enabled for TX, HDMI TX core includes I2C master with I2C serial interface exposed for the connection to the HDMI connector. I2C master will also expose Avalon-MM interface for the user control using NIOS. |

Related Information

- [HDMI Intel Arria 10 FPGA IP Design Example User Guide](#)
For more information about the HDCP over HDMI design example for Intel Arria 10 devices and the security considerations when using the HDCP features.
- [HDMI Intel Stratix 10 FPGA IP Design Example User Guide](#)
For more information about the HDCP over HDMI design example for Intel Stratix 10 devices and the security considerations when using the HDCP features.



8. HDMI Simulation Example

The HDMI simulation example evaluates the functionality of the HDMI Intel FPGA IP and provides a starting point for you to create your own simulation.

This simulation example targets the ModelSim - Intel FPGA Starter Edition simulator. The simulation covers the following core features:

- IEC-60958 audio format
- Standard H/V/DE/RGB input video format
- Support for HDMI 2.0b scrambled operation

Note:

This simulation flow applies only for the Intel Quartus Prime Standard Edition software using ModelSim - Intel FPGA Starter Edition. For the Intel Quartus Prime Pro Edition simulation flow, refer to the respective design example user guides.

Figure 67. HDMI Testbench

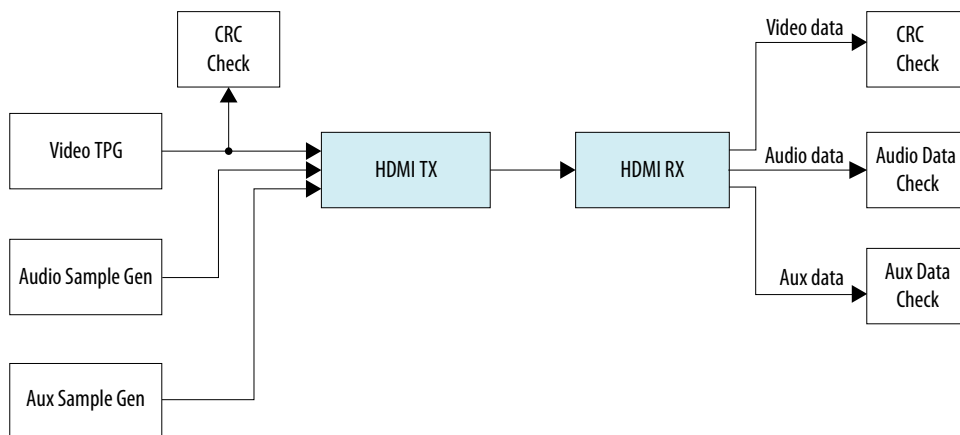

The Test Pattern Generator (TPG) provides the video stimulus. The IP core stimulates the HDMI TX core using an audio packet generator and aux packet generator. The output from the HDMI TX core drives the HDMI RX core.

The IP core requires a memory-mapped master stimulus to operate the testbench for HDMI 2.0b scrambling. This stimulus implements the activity normally seen across the I²C DDC channel. At this point, the IP core asserts the scramble enable bit in the SCDC registers.

The testbench implements CRC checking on the input and output video. The testbench checks the CRC value of the transmitted data against the CRC calculated in the received video data. The testbench performs the checking after detecting 4 stable V-SYNC signals from the receiver.

The aux sample generator generates a fixed data to be transmitted from the transmitter. On the receiver side, the generator compares whether the expected aux data is received and decoded correctly.

The audio sample generator generates an incrementing test data pattern to be transmitted through the audio channel. On the receiver side, the audio data checker checks and compares whether the incrementing test data pattern is received and decoded correctly.

8.1. Simulation Walkthrough

Setting up and running the HDMI simulation example consists of two steps.

Note: This simulation flow applies only to Intel Quartus Prime Standard Edition using ModelSim - Intel FPGA Starter Edition. For Intel Quartus Prime Pro Edition flow, refer to the respective *Design Example User Guides*.

Note: When I2C Master/Slave parameter is turned on, simulation design example is not supported.

1. Copy the simulation files from <IP root directory>/altera/altera_hdmi/sim_example to your working directory.
2. Generate the IP simulation files and scripts, compile, and simulate.

- a. Start the Nios II Command Shell.
- b. Type the command below and enter.

```
sh runall.sh
```

This script executes the following commands:

| Command | |
|--|--|
| Generate the simulation files for the HDMI cores. | <ul style="list-style-type: none"> • ip-generate --project-directory=./ --component-file=./hdmi_rx_single.qsys --output-directory=./hdmi_rx_single/sim/ --file-set=SIM_VERILOG --report-file=sopcinfo:./hdmi_rx_single.sopcinfo --report-file=html:./hdmi_rx_single.html --report-file=spd:./hdmi_rx_single/sim/hdmi_rx_single.spd --report-file=qip:./hdmi_rx_single/sim/hdmi_rx_single.qip • ip-generate --project-directory=./ --component-file=./hdmi_rx_double.qsys --output-directory=./hdmi_rx_double/sim/ --file-set=SIM_VERILOG --report-file=sopcinfo:./hdmi_rx_double.sopcinfo --report-file=html:./hdmi_rx_double.html --report-file=spd:./hdmi_rx_double/sim/hdmi_rx_double.spd --report-file=qip:./hdmi_rx_double/sim/hdmi_rx_double.qip • ip-generate --project-directory=./ --component-file=./hdmi_tx_single.qsys --output-directory=./hdmi_tx_single/sim/ --file-set=SIM_VERILOG --report-file=sopcinfo:./hdmi_tx_single.sopcinfo --report-file=html:./hdmi_tx_single.html --report-file=spd:./hdmi_tx_single/sim/hdmi_tx_single.spd --report-file=qip:./hdmi_tx_single/sim/hdmi_tx_single.qip • ip-generate --project-directory=./ --component-file=./hdmi_tx_double.qsys --output-directory=./hdmi_tx_double/sim/ --file-set=SIM_VERILOG --report-file=sopcinfo:./hdmi_tx_double.sopcinfo --report-file=html:./hdmi_tx_double.html --report-file=spd:./hdmi_tx_double/sim/hdmi_tx_double.spd --report-file=qip:./hdmi_tx_double/sim/hdmi_tx_double.qip |
| Merge the four resulting msim_setup.tcl scripts to create a single mentor/msim_setup.tcl script. | ip-make-simscrip --spd=./hdmi_tx_single/sim/hdmi_tx_single.spd --spd=./hdmi_tx_double/sim/hdmi_tx_double.spd --spd=./hdmi_rx_single/sim/hdmi_rx_single.spd --spd=./hdmi_rx_double/sim/hdmi_rx_double.spd |
| Compile and simulate the design in the ModelSim software. | vsim -c -do msim_hdmi.tcl |
| Generate the simulation files for the HDMI cores. | |
| Merge the resulting msim_setup.tcl scripts to create a single mentor/msim_setup.tcl script. | |
| Compile and simulate the design in the ModelSim software. | |

Example successful result:

```
# SYMBOLS_PER_CLOCK = 4
# VIC = 0
# AUDIO_CLK_DIVIDE = 800
```

8. HDMI Simulation Example

683798 | 2021.11.12



```
# TEST_HDMI_6G = 1
# Simulation pass
# ** Note: $finish : bitec_hdmi_tb.v (647)
#       Time: 15702552 ns Iteration: 3 Instance: /bitec_hdmi_tb
# End time: 14:39:02 on Feb 04,2016, Elapsed time: 0:03:17
# Errors: 0, Warnings: 134
```

9. HDMI Intel FPGA IP User Guide Archives

IP versions are the same as the Intel Quartus Prime Design Suite software versions up to 19.1. From Intel Quartus Prime Design Suite software version 19.2 or later, IP cores have a new IP versioning scheme.

If an IP core version is not listed, the user guide for the previous IP core version applies.

| Intel Quartus Prime Version | IP Core Version | User Guide |
|-----------------------------|-----------------|---|
| 21.1 | 19.6.0 | HDMI Intel FPGA IP User Guide |
| 20.4 | 19.6.0 | HDMI Intel FPGA IP User Guide |
| 20.3 | 19.5.0 | HDMI Intel FPGA IP User Guide |
| 20.2 | 19.4.0 | HDMI Intel FPGA IP User Guide |
| 20.1 | 19.4.0 | HDMI Intel FPGA IP User Guide |
| 19.4 | 19.3.0 | HDMI Intel FPGA IP User Guide |
| 19.3 | 19.1.0 | HDMI Intel FPGA IP User Guide |
| 19.1 | 19.1 | HDMI Intel FPGA IP User Guide |
| 18.1 | 18.1 | HDMI Intel FPGA IP User Guide |
| 18.0 | 18.0 | HDMI Intel FPGA IP User Guide |
| 17.1 | 17.1 | HDMI IP Core User Guide |
| 17.0 | 17.0 | HDMI IP Core User Guide |
| 16.1 | 16.1 | HDMI IP Core User Guide |
| 16.0 | 16.0 | HDMI IP Core User Guide |
| 15.1 | 15.1 | HDMI IP Core User Guide |
| 15.0 | 15.0 | HDMI IP Core User Guide |
| 14.1 | 14.1 | HDMI IP Core User Guide |

10. Document Revision History for the HDMI Intel FPGA IP User Guide

| Document Version | Intel Quartus Prime Version | IP Version | Changes |
|------------------|-----------------------------|------------|---|
| 2021.11.12 | 21.3 | 19.6.1 | <ul style="list-style-type: none"> Updated Table <i>HDCP Resource Utilization</i> for Support HDCP Key Management = 1. Updated Table <i>HDMI Source Parameters</i> and <i>HDMI Sink Parameters</i> for Support HDCP Key Management. |
| 2021.08.06 | 21.2 | 19.6.1 | <ul style="list-style-type: none"> Added the link for <i>Intel Arria 10 HDMI 2.1 System Design Guidelines</i> in <i>HDMI Intel FPGA IP Quick Reference</i>. Changed the <i>TMDS Clock Rate (MHz)</i> for <i>Stratix V</i> in Table: <i>HDMI PLL Desired Output Frequencies for 8-bpc Video</i>. Edited the description from <i>HDMI 1.4b</i> to <i>HDMI 2.0</i> in <i>Source Scramble, TMDS/TERC4 Encoder</i>. Edited Figure: <i>Typical Window of Opportunity for H sync</i> to asserted when V Sync is high. Edited the <i>Description</i> for <i>Encoder Control Port</i> and <i>I²C Master Interface Port</i> in Table: <i>HDMI Source Interfaces</i>. Edited the <i>Description</i> for <i>Decoder Status Port</i> in Table: <i>HDMI Sink Interfaces</i>. |
| 2021.06.25 | 21.2 | 19.6.1 | <ul style="list-style-type: none"> Updated Table: <i>HDMI Intel FPGA IP FRL Feature Support in Intel Stratix 10 and Intel Arria 10 Devices</i> and added <i>Arria 10</i> as <i>Final</i> and <i>Stratix 10</i> as <i>Preliminary</i> for <i>Support FRL = 1</i>. Updated Table: <i>HDMI Intel FPGA IP Resource Utilization</i> and added the performance data for <i>Intel Arria 10 (Support FRL = 1)</i>. Edited the description in <i>Source Audio Encoder</i>. Updated Table: <i>HDMI Source Interfaces</i> in <i>Source Interfaces</i>: <ul style="list-style-type: none"> Updated the <i>Description</i> for <i>vid_clk</i> Port, <i>vid_ready</i> Port and <i>vid_valid</i> Port. Edited the <i>Clock Domain</i> and <i>Description</i> for <i>TMDS/FRL Data Port</i> Interface. Edited the <i>Clock Domain</i> for <i>Encoder Control Port Interface, PHY Interface Control Port</i> and <i>Hot Plug Detect</i>. Updated <i>Source Clock Tree</i>: <ul style="list-style-type: none"> Edited the description. Added Figure: <i>Source clock tree when Support FRL = 1</i>. Added Figure: <i>Source clock tree when Support FRL = 0</i>. Added <i>Intel Stratix 10</i> in <i>Link Training Procedure</i>. |

continued...

Intel Corporation. All rights reserved. Intel, the Intel logo, and other Intel marks are trademarks of Intel Corporation or its subsidiaries. Intel warrants performance of its FPGA and semiconductor products to current specifications in accordance with Intel's standard warranty, but reserves the right to make changes to any products and services at any time without notice. Intel assumes no responsibility or liability arising out of the application or use of any information, product, or service described herein except as expressly agreed to in writing by Intel. Intel customers are advised to obtain the latest version of device specifications before relying on any published information and before placing orders for products or services.

*Other names and brands may be claimed as the property of others.

| Document Version | Intel Quartus Prime Version | IP Version | Changes |
|---------------------|-----------------------------|------------|--|
| | | | <ul style="list-style-type: none"> • Updated <i>FRL CLocking Scheme</i>: <ul style="list-style-type: none"> – Updated the description and the calculation to configure <code>vid_clk</code> to the maximum frequency. – Removed column <i>Is_clk Frequency (MHz)</i> from the Table: <i>Clock Frequencies for FRL Mode at Different Link Rates</i>. • Updated <i>Valid Video Data</i>: <ul style="list-style-type: none"> – Updated the description and Figure: <i>Video Clock Running at Faster Frequency</i>. – Added Figure: <i>Timing diagram for the vid_valid generation</i>. • Added topic <i>Variable Refresh Rate(VRR) and Auto Low Latency Mode (ALLM)</i> in <i>HDMI Source</i> and <i>HDMI Sink</i>. • Removed Table: <i>Auxiliary Packet Memory Map</i> and Table: <i>Packet Payload Data Byte</i> from <i>Sink Auxiliary Packet Capture</i>. • Updated <i>Sink Auxiliary Data Port</i> and added the following topics: <ul style="list-style-type: none"> – <i>Sink General Control Packet (GCP)</i>. – <i>Sink Auxiliary Video Information (AVI) InfoFrame Bit-Fields</i>. – <i>Sink HDMI Vendor Specific InfoFrame (VSI)</i>. • Updated <i>Sink Audio Decoder</i> and added the following topics:: <ul style="list-style-type: none"> – <i>Audio InfoFrame (AI) Bundle Bit-Fields</i>. – <i>Audio Metadata Bundle Bit-Fields</i>. • Updated Table: <i>Sink Interfaces</i> in <i>Sink Interfaces</i>: <ul style="list-style-type: none"> – Updated the <i>Description</i> for <i>Is_clk</i>. – Edited the <i>Clock Domain</i> for <i>TMDS/FRL Data Port</i> Interface. – Edited the <i>Clock Domain</i> for <i>Decoder Status Port</i> Interface. • Updated <i>Sink Clock Tree</i> : <ul style="list-style-type: none"> – Added Figure: <i>Sink clock tree when Support FRL = 1</i>. – Added Figure: <i>Sink clock tree when Support FRL = 0</i>. • Edited the description in <i>Link Training Procedure</i>. • Updated Table: <i>HDMI Source Parameters</i> and <i>HDMI Sink Parameters</i>: <ul style="list-style-type: none"> – Edited the description for <i>Support Auxiliary</i> parameter. – Added the row <i>Include I2C Master/Slave</i>. |
| continued... | | | |

| Document Version | Intel Quartus Prime Version | IP Version | Changes |
|------------------|-----------------------------|------------|--|
| 2021.05.12 | 21.1 | 19.6.0 | <ul style="list-style-type: none"> Removed (<i>Support FRL = 0 only</i>) from <i>Support HDCP 2.3</i> and <i>Support HDCP 1.4</i> in Table : <i>HDMI Source Interfaces</i> and Table : <i>HDMI Sink Interfaces</i>. Added <i>Support HDCP Key Management</i> in Table: <i>HDMI Source Interfaces</i> and Table: <i>HDMI Sink Interfaces</i>. Added Table: <i>Source Interfaces</i> and <i>Sink Interfaces</i>: <ul style="list-style-type: none"> Added <i>This signal is not available if you turn on the Support HDCP Key Management parameter</i> under the description for <i>Conduit (Key)</i> port type. Changed the port name from <i>kmem_addr</i> to <i>kmem_raddr</i>. Changed the port name from <i>kmem_rddata</i> to <i>kmem_q</i>. Added <i>Avalon-MM</i> port type. |
| 2021.04.01 | 21.1 | 19.6.0 | <ul style="list-style-type: none"> Updated Table: <i>Sink Interfaces</i>: <ul style="list-style-type: none"> Updated the descriptions for the <i>sdc_frl_ltp_req</i> port. Edited the port name <i>rx_hpd</i> to <i>rx_hpd_req</i>, change the direction from <i>Inout</i> to <i>Output</i> and updated the descriptions. Updated <i>Link Training Procedure</i>. Removed Figure <i>Link Training Pattern</i>. |
| 2020.12.14 | 20.4 | 19.6.0 | <ul style="list-style-type: none"> Added support for HDMI 2.1 with fixed rate link (FRL) enabled for Intel Stratix 10 devices. Edited the description in the <i>HDMI Overview</i> section. Updated table title <i>HDMI Intel FPGA IP FRL Feature Support in Intel Arria 10 Devices Feature Support Level Support FRL</i> to <i>HDMI Intel FPGA IP FRL Feature Support in Intel Stratix 10 and Intel Arria 10 Devices Feature Support Level Support FRL</i>. Updated the maximum data rates for Intel Stratix 10 devices in Table: <i>HDMI Data Rate</i>. Updated the resource utilization data in Table: <i>HDMI Intel FPGA IP Resource Utilization</i> and Table: <i>HDCP Resource Utilization</i>. Updated table title <i>Recommended Speed Grades for Intel Arria 10 Devices (Support FRL = 1)</i> to <i>Recommended Speed Grades for Intel Stratix 10 and Intel Arria 10 Devices (Support FRL = 1)</i> and added recommended speed grades for Intel Stratix 10 devices. Updated the <i>FRL Clocking Scheme</i> section: <ul style="list-style-type: none"> Edited the FRL character processing description and associated figure. Added <i>frl_clk</i> frequency for Intel Stratix 10 devices in Table: <i>Clock Frequencies for FRL Mode at Different Link Rates</i>. Edited the minimum and maximum TX clkout frequencies for <i>TMDS_BIT_CLOCK_RATIO = 0</i> in Table: <i>Clock Frequencies for TMDS Mode at Different Link Rates</i>. Updated the description for the <i>kmem_addr[3:0]</i> (HDCP 2.3) and <i>kmem_addr[9:4]</i> (HDCP 1.4) ports in Table: <i>HDMI Source Interfaces</i>. |

continued...

| Document Version | Intel Quartus Prime Version | IP Version | Changes |
|------------------|-----------------------------|------------|--|
| | | | <ul style="list-style-type: none"> Updated Table: <i>Sink Interfaces</i>: <ul style="list-style-type: none"> Updated the descriptions for the <code>vid_lock</code> port. Edited the port name <code>kmem_addr[3:0]</code> (HDCP 2.3) to <code>kmem_addr[7:0]</code> (HDCP 2.3), and <code>kmem_addr[9:4]</code> (HDCP 1.4) to <code>kmem_addr[13:8]</code> (HDCP 1.4). Updated the description for the <code>kmem_rddata[31:0]</code> (HDCP 2.3) and <code>kmem_rddata[87:32]</code> (HDCP 1.4) ports. Edited the description in the <i>Sink FRL Resampler</i> section. Edited the description in the <i>Sink Clock Tree</i> section. Updated the following figures: <ul style="list-style-type: none"> <i>HDMI Source Signal Flow Diagram for Support FRL = 1 Design</i> <i>HDMI Sink Signal Flow Diagram for Support FRL = 1 Design</i> Edited the descriptions for Device family, Pixels per clock, Transceiver width, Support deep color, Support HDCP 2.3, Support HDCP 1.4, and Support FRL in Table: <i>HDMI Source Parameters</i> and Table: <i>HDMI Sink Parameters</i>. Removed the support for 4 symbols per clock feature in the <i>HDMI Simulation Example</i> section. Made editorial edits throughout the document. |
| 2020.09.28 | 20.3 | 19.5.0 | <ul style="list-style-type: none"> The FRL path now uses the transceiver recovered clock domain instead of the <code>ls_clk</code> domain. Updated the following Source sections with the transceiver recovered clock domain information. <ul style="list-style-type: none"> <i>Source Functional Description</i> <i>Source FRL Resampler</i> <i>Source Clock Tree</i> Edited the description for the <code>ls_clk</code> signal in the <i>Source Interfaces</i> section. Added the following signals in the <i>Source Interfaces</i> section. <ul style="list-style-type: none"> <code>tx_clk</code> <code>os</code> <code>mgmt_clk</code> <code>in_lock</code> <code>tx_hpd</code> <code>tx_hpd_req</code> <code>i2c_scl</code> <code>i2c_sda</code> <code>i2c_master_address[3:0]</code> <code>i2c_master_write</code> <code>i2c_master_read</code> <code>i2c_master_writedata[31:0]</code> <code>i2c_master_readdata[31:0]</code> <code>mgmt_clk</code> Removed the <code>ls_clk</code> domain information from the <i>FRL Clocking Scheme</i> section. |

continued...

| Document Version | Intel Quartus Prime Version | IP Version | Changes |
|------------------|-----------------------------|------------|--|
| | | | <ul style="list-style-type: none"> • Removed the <code>ls_clk</code> domain information and updated the block diagram and the timing diagrams with the transceiver recovered clock information in the <i>Source Deep Color Implementation When Support FRL = 1</i> section. • Added the following new Source sections: <ul style="list-style-type: none"> – <i>TX Oversampler</i> – <i>Clock Enable Generator</i> – <i>I²C Master</i> • Updated the following Sink sections with the transceiver recovered clock domain information. <ul style="list-style-type: none"> – <i>Sink Functional Description</i> – <i>Sink FRL Resampler</i> – <i>Sink Clock Tree</i> • Added the following new Sink sections: <ul style="list-style-type: none"> – <i>RX Oversampler</i> – <i>I2C Slave</i> – <i>EDID RAM</i> • Edited the description for the <code>ls_clk</code> signal and added information about the transceiver recovered clock, oversampling (<code>os</code>), I2C slave, and the EDID RAM signals in the <i>Sink Interfaces</i> section. • Added a note in the description for the <code>mode</code> signal in the <i>Sink Interfaces</i> section. This signal is unused in FRL mode. • Edited the <code>scdc_i2c_clk</code> clock domain to <code>i2c_clk</code> clock domain in the <i>Status and Control Data Channel (SCDC) Interface</i> and <i>Sink Interfaces</i> sections. • Edited the typo in the color depth ratio for 8 bits per color in the <i>Sink Deep Color Implementation When Support FRL = 0</i> section. The correct color depth ratio for 8 bits per color should be 1.0, not 1.6. • Removed the <code>ls_clk</code> domain information and updated the block diagram and the timing diagrams with the transceiver recovered clock information in the <i>Sink Deep Color Implementation When Support FRL = 1</i> section. • Updated the <i>HDMI Parameters</i> section with the following new parameters information. <ul style="list-style-type: none"> – Include I2C – Include EDID RAM – EDID RAM size – RAM file path – HPD polarity • Added a note about the TMDS bit rate and TMDS character rate information in the <i>PLL Intel FPGA IP Cores</i> section. |
| | | | <i>continued...</i> |

| Document Version | Intel Quartus Prime Version | IP Version | Changes |
|------------------|-----------------------------|------------|--|
| 2020.06.02 | 20.2 | 19.4.0 | <ul style="list-style-type: none"> Updated HDCP feature support for Intel Stratix 10 devices. <i>Note:</i> The HDCP feature is not included in the Intel Quartus Prime Pro Edition software. To access this feature, contact Intel at https://www.intel.com/content/www/us/en/broadcast/products/programmable/applications/connectivity-solutions.html. Updated the HDCP resource utilization data for Intel Arria 10 devices and added data for Intel Stratix 10 devices in the <i>Resource Utilization</i> section. Updated the HDCP 1.4 Key Port address information in <i>HDCP 1.4 TX Architecture</i> and <i>HDCP 1.4 RX Architecture</i> sections. Added information about the <code>reset_vid</code>, <code>hdcp1_disable</code>, and <code>hdcp2_disable</code> signals in the <i>Source Interfaces</i> section. Added information about the <code>reset_vid</code>, <code>streamid_type</code>, <code>hdcp1_disable</code>, and <code>hdcp2_disable</code> signals in the <i>Sink Interfaces</i> section. Added a note and edited the bit-field information in the <i>Source HDMI Vendor Specific InfoFrame (VSI)</i> section. For the HF-VSIF transmission, use external VSI by asserting control bit to 1 and send the data through the Auxiliary Data Port. |
| 2020.04.13 | 20.1 | 19.4.0 | <ul style="list-style-type: none"> Updated the data rate for Intel Arria 10 devices in the <i>Resource Utilization</i> section. Removed the <i>HDCP Over HDMI Design Examples for Intel Arria 10 Devices</i> section. This information is now available in the <i>HDMI Intel Arria 10 FPGA IP Design Example User Guide</i>. Edited the port bit in <code>avi[121]</code> to <code>avi[122]</code> in the <i>Source Auxiliary Control Port</i> and <i>Source Interfaces</i> sections. Removed the AVI version bit information and added information about setting the AVI version for Support FRL = 1 in the <i>Source Auxiliary Video Information</i> section. Added <i>HDMI 2.1 Specification</i> reference for FRL mode in the <i>Source Audio Encoder</i> section. Edited the description for <code>ls_clk</code>, <code>vid_clk</code>, and <code>frl_clk</code> in the <i>Source Interfaces</i> and <i>Sink Interfaces</i> sections. Edited the clocks information in the <i>FRL Clocking Scheme</i> section. |

continued...



| Document Version | Intel Quartus Prime Version | IP Version | Changes |
|------------------|-----------------------------|------------|--|
| | | | <ul style="list-style-type: none"> • Added the following sections for deep color implementation: <ul style="list-style-type: none"> – <i>Source Deep Color Implementation When Support FRL = 0</i> – <i>Source Deep Color Implementation When Support FRL = 1</i> – <i>Sink Deep Color Implementation When Support FRL = 0</i> – <i>Sink Deep Color Implementation When Support FRL = 1</i> • Edited the port bit in <code>info_avi[120]</code> to <code>info_avi[122]</code> in the <i>Sink Interfaces</i> section. • Added a note in the <i>HDMI Simulation Example</i> section that the simulation flow applies only for the Intel Quartus Prime Standard Edition software using ModelSim - Intel FPGA Starter Edition. For the Intel Quartus Prime Pro Edition simulation flow, refer to the respective design example user guides. |
| 2020.02.10 | 19.4 | 19.3.0 | <ul style="list-style-type: none"> • Added support for HDMI 2.1 with fixed rate link (FRL) enabled. This feature is available only for Intel Arria 10 devices. • Added information that HDMI 2.1 supports pixel frequency up to 1,118 MHz and supports only 8 bits per component in the <i>HDMI Intel FPGA IP Quick Reference</i> section. • Added information about FRL in the <i>HDMI Overview</i> section. • Added information about the signal flow for Support FRL = 1 in the <i>Source Functional Description</i> and <i>Sink Functional Description</i> sections. • Updated the <i>Source Auxiliary Video Information (AVI) InfoFrame</i> section with Support FRL = 1 information. • Updated the <i>Source Clock Tree</i> and <i>Sink Clock Tree</i> sections with FRL information. • Updated the <i>Source Interfaces</i> and <i>Sink Interfaces</i> sections with FRL information. • Updated the <i>HDMI Parameters</i> section to include Support FRL parameter. |

continued...

| Document Version | Intel Quartus Prime Version | IP Version | Changes |
|------------------|-----------------------------|------------|--|
| | | | <ul style="list-style-type: none"> Added the following new sections in the <i>HDMI Source</i> chapter: <ul style="list-style-type: none"> – <i>FRL Packetizer</i> – <i>FRL Character Block and Super Block Mapping</i> – <i>Reed Solomon (RS) Forward Error Correction (FEC) Generation and Insertion</i> – <i>FRL Scrambler and Encoder</i> – <i>Source FRL Resampler</i> – <i>FRL Clocking Scheme</i> – <i>Valid Video Data</i> – <i>Source Link Training Procedure</i> Added the following new sections in the <i>HDMI Sink</i> chapter: <ul style="list-style-type: none"> – <i>FRL Depacketizer</i> – <i>Sink FRL Character Block and Super Block Demapper</i> – <i>Sink FRL Descrambler and Decoder</i> – <i>Sink FRL Resampler</i> – <i>Sink Link Training Procedure</i> Updated the diagrams in the <i>Source Clock Tree</i> and <i>Sink Clock Tree</i> sections. |
| 2019.10.10 | 19.3 | 19.1.0 | <ul style="list-style-type: none"> Added a new section about High-bandwidth Digital Content Protection (HDCP). This feature is available only for Intel Arria 10 devices. <i>Note:</i> The HDCP feature is not included in the Intel Quartus Prime Pro Edition software. To access this feature, contact Intel at https://www.intel.com/content/www/us/en/broadcast/products/programmable/applications/connectivity-solutions.html. Added information about the following HDCP-related parameters in the <i>HDMI Source Parameters</i> and <i>HDMI Sink Parameters</i> sections: <ul style="list-style-type: none"> – Support HDCP 1.4 – Support HDCP 2.3 Added information about HDCP-related signals in the <i>Source Interfaces</i> and <i>Sink Interfaces</i> sections. Added information about a new design example that demonstrates the HDCP feature for Intel Arria 10 devices in the Intel Quartus Prime Pro Edition software. |
| | | | <i>continued...</i> |

| Document Version | Intel Quartus Prime Version | IP Version | Changes |
|------------------|-----------------------------|------------|---|
| 2019.04.29 | 19.1 | 19.1 | <ul style="list-style-type: none"> Added support for Intel Stratix 10 L-tile devices. Support for both Intel Stratix 10 L-tile and H-tile devices are final. Updated the support for YCbCr 4:2:2 pixel encoding in the <i>Resource Utilization</i> section. The HDMI IP core supports 8-bit and 10-bit color depth for YCbCr 4:2:2 pixel encoding. Added performance data for Intel Stratix 10 L-tile and H-tile devices, and updated the data for Intel Arria 10 and Intel Cyclone 10 GX devices for version 19.1. Updated the description for the <code>locked[2:0]</code>, <code>in_lock[2:0]</code>, and <code>ctrl[N*6-1:0]</code> ports. Added information insertion and filtration for the control ports in the <i>Source Auxiliary Control Port</i> section. |
| 2019.01.21 | 18.1 | 18.1 | <ul style="list-style-type: none"> Added a note in the <i>Sink Word Alignment and Channel Deskew</i> section that the word alignment logic in the HDMI RX core is disabled for HDMI 2.0 resolution (data rate >3.4 Gbps) in Intel Arria 10 and Intel Cyclone 10 GX devices. For Intel Stratix 10 devices, the HDMI RX core uses a new word alignment algorithm logic to achieve fast word alignment time for HDMI 2.0 resolution (data rate >3.4Gbps). Updated the description for the <code>vid_lock</code> port to add that the IP detects HTotal, VTotal, HSync Width, VSync Width, HSync Polarity, and VSync Polarity. and a change in these parameters across two frames will deassert the <code>vid_lock</code> signal. |
| 2018.05.07 | 18.0 | 18.0 | <ul style="list-style-type: none"> Update the HDMI specification reference to 2.0b. The HDMI Intel FPGA IP core now supports <i>HDMI Specification 2.0b</i>. Added preliminary support for Intel Stratix 10 (H-Tile) devices. Updated support for Intel Cyclone 10 GX devices to final. Clarified in the features list that HDMI IP core supports up to 32 channels in 2-channel or 8-channel layouts. Added link to the <i>HDMI Intel Cyclone 10 GX FPGA IP Design Example User Guide</i>. Updated all IP names as part of standardization and rebranding exercise. Removed a note that said the HDMI RX core does not support SCDC read request feature for this release. The HDMI RX core fully supports SCDC features since version 17.1. Added a note in the <i>Sink Clock Tree</i> section that GPLL refers to IOPLL Intel FPGA IP for Intel Arria 10, Intel Cyclone 10 GX, and Intel Stratix 10 devices; PLL Intel FPGA IP for Arria V and Stratix V devices. Edited the recommended speed grade information for Intel Cyclone 10 GX. The recommended speed grade is -5. Edited typo in <i>3D Audio Input Example</i> figure. Changed the term <i>Video Format</i> to <i>Pixel Encoding</i> to be consistent with <i>HDMI Specification 2.0b</i>. Restructured the document. Placed the <i>HDMI Hardware Design</i> chapter after the <i>HDMI Getting Started</i> chapter. |

| Date | Version | Changes |
|---------------------|------------|---|
| November 2017 | 2017.11.06 | <ul style="list-style-type: none"> • Added advance support for Intel Cyclone 10 GX devices. • Added resource utilization data for Intel Cyclone 10 GX devices. • Changed <i>bits per color (bpc)</i> to <i>bits per component (bpc)</i> as stated in the <i>HDMI Specification 2.0</i>. • Renamed HDMI IP core to HDMI Intel FPGA IP as per Intel rebranding. • Changed the term Qsys to Platform Designer. • Reorganized and updated the <i>Source Functional Description</i> and <i>Source Functional Description</i> sections for better understanding. • Added description for the following new bit-fields: <ul style="list-style-type: none"> — Audio InfoFrame Bundle Bit-fields — Audio Metadata Bundle Bit-Fields for Packet Header and Control — Audio Metadata Bundle Bit-Fields for Packet Content When 3D_AUDIO = 1 — Audio Metadata Bundle Bit-Fields for Packet Content When 3D_AUDIO = 0 • Added support for up to 32 audio channels. • Added support for up to 1,536 kHz audio sample frequency. • Updated the <i>3D Audio Format</i> section and the description for <code>audio_clk</code> that for audio channels greater than 8, do not drive <code>audio_clk</code> at actual audio sample clock. Instead drive <code>audio_clk</code> with <code>ls_clk</code> and qualify <code>audio_data</code> with <code>audio_de</code> • Updated the <i>HDMI Intel FPGA IP Source Clock Tree</i> and <i>HDMI Intel FPGA IP Sink Clock Tree</i> sections. • Updated the <i>HDMI Intel FPGA IP Source Parameter</i> and <i>HDMI Intel FPGA IP Sink Parameter</i> sections. • Updated the <i>HDMI Intel FPGA IP Source Interfaces</i> and <i>HDMI Intel FPGA IP Sink Interfaces</i> sections. • Updated the description for the Support for deep color parameter. The parameter is now turned on by default. • Edited the HDMI Intel FPGA IP testbench block diagram. Removed 4 symbols/clock to avoid confusion. • Added a note in the <i>HDMI Intel FPGA IP Hardware Demonstration</i> section that the demonstration is only applicable for Arria V and Stratix V devices. For Intel Arria 10 devices, refer to the <i>HDMI Intel FPGA IP Design Example User Guide for Intel Arria 10 Devices</i>. • Added a note in the <i>Simulation Walkthrough</i> section that the walkthrough is only applicable for Intel Quartus Prime Standard Edition. For Intel Quartus Prime Pro Edition, refer to the <i>HDMI Intel FPGA IP Design Example User Guide for Intel Arria 10 Devices</i>. • Moved information about the HDMI Intel FPGA IP design example parameters to the <i>HDMI Intel FPGA IP Design Example User Guide for Intel Arria 10 Devices</i>. |
| May 2017 | 2017.05.08 | <ul style="list-style-type: none"> • Rebranded as Intel. • Added recommended speed grades for Intel Arria 10 devices. |
| December 2016 | 2016.12.20 | <ul style="list-style-type: none"> • Updated the HDMI IP core resource utilization table with 16.1 information. • Added a note for YCbCr 4:2:2 video format that 8 and 10 bits per color use the same pixel encoding as 12 bits per color, but the valid bits are left-justified with zeros padding the bits below the least significant bit. • Added information for the new Design Example parameters. • Removed all Arria 10 design example related information. For more information about Arria 10 design examples, refer to the <i>HDMI IP Core Design Example User Guide</i>. • Edited the typos in the HDMI Audio Format topic. • Added information that the HDMI IP core does not support 8-channel audio. • Added a new output port <code>version[31:0]</code> for HDMI source and sink. |
| <i>continued...</i> | | |

| Date | Version | Changes |
|---------------|------------|--|
| May 2016 | 2016.05.02 | <ul style="list-style-type: none"> • Updated the HDMI IP core resource utilization table with 16.0 information. • Added information about Audio Metadata Packet for <i>HDMI Specification Version 2.0</i>. • Added information about new HDMI source ports: <ul style="list-style-type: none"> – audio_metadata[164:0] – audio_format[4:0] • Added information about new HDMI sink ports: <ul style="list-style-type: none"> – audio_metadata[164:0] – audio_format[4:0] – vid_lock – aux_error • Provided detailed information about the HDMI source and sink audio_de[7:0] port. • Updated the testbench diagram and description to include audio data and auxiliary data information. • Added a note for Altera PLL to place the PLL in the transmit path (pll_hdmi_tx) in the physical location next to the transceiver PLL. • Updated the HDMI sideband signals (HDMI AVI and VSI bit-fields) with default values. • Added links to archived versions of the <i>HDMI IP Core User Guide</i>. |
| November 2015 | 2015.11.02 | <ul style="list-style-type: none"> • Updated the HDMI IP core resource utilization table with 15.1 information. • Changed instances of <i>Quartus II</i> to <i>Intel Quartus Prime</i>. • Added full support for Arria 10 devices. • Added support for new features: <ul style="list-style-type: none"> – Deep color – 8-channel audio • Added the following parameters for HDMI source: <ul style="list-style-type: none"> – Support for 8-channel audio – Support for deep color • Added the following parameters for HDMI sink: <ul style="list-style-type: none"> – Support for 8-channel audio – Support for deep color – Manufacturer OUI – Device ID String – Hardware Revision • Updated the following interface ports for HDMI source: <ul style="list-style-type: none"> – Added ctrl port – Removed gcp_Set_AVMute and gcp_Clear_AVMute ports • Updated the following interface ports for HDMI sink: <ul style="list-style-type: none"> – Added ctrl, mode, in_5v_power, and in_hpd ports – Removed gcp_Set_AVMute and gcp_Clear_AVMute ports • Updated the HDMI sink and source block diagrams to reflect the new features. • Provided block diagrams for deep color mapping. • Generalized the HDMI hardware demonstration design for all supported device families (Arria V, Stratix V, and Arria 10) with detailed description. |
| May 2015 | 2015.05.04 | <ul style="list-style-type: none"> • Updated the HDMI IP core resource utilization table with 15.0 information. • Added information about 4 symbols per clock mode. • Added information about Status and Control Data Channel (SCDC) for <i>HDMI specification version 2.0</i>. • Added the following interface ports for HDMI source: <ul style="list-style-type: none"> – TMSD_Bit_clock_Ratio – Scrambler_Enable |

continued...

| Date | Version | Changes |
|---------------|------------|---|
| | | <ul style="list-style-type: none">• Added the TMD5_Bit_clock_Ratio interface port for HDMI sink.• Updated the HDMI hardware demonstration design with HDMI 2.0 information.• Added software process flow for the HDMI hardware demonstration. |
| December 2014 | 2014.12.15 | Initial release. |

X-ON Electronics

Largest Supplier of Electrical and Electronic Components

Click to view similar products for [Development Software](#) category:

Click to view products by [Intel](#) manufacturer:

Other Similar products are found below :

[RAPPID-567XFSW](#) [SRP004001-01](#) [SW163052](#) [SYSWINEV21](#) [Core429-SA](#) [WS01NCTF1E](#) [W128E13](#) [SW89CN0-ZCC](#) [IPS-EMBEDDED](#)
[IP-UART-16550](#) [MPROG-PRO535E](#) [AFLCF-08-LX-CE060-R21](#) [WS02-CFSC1-EV3-UP](#) [SYSMAC-STUDIO-EIPCPLR](#) [LIB-PL-PC-N-](#)
[1YR-DISKID](#) [LIB-PL-A-F](#) [SW006026-COV](#) [1120270005](#) [1120270006](#) [MIKROBASIC PRO FOR FT90X \(USB DONGLE\)](#) [MIKROC PRO](#)
[FOR FT90X \(USB DONGLE\)](#) [MIKROC PRO FOR PIC \(USB DONGLE LICENSE\)](#) [MIKROBASIC PRO FOR AVR \(USB DONGLE LICEN](#)
[MIKROBASIC PRO FOR FT90X](#) [MIKROC PRO FOR DSPIC30/33 \(USB DONGLE LI](#) [MIKROPASCAL PRO FOR ARM \(USB DONGLE](#)
[LICE](#) [MIKROPASCAL PRO FOR FT90X](#) [MIKROPASCAL PRO FOR FT90X \(USB DONGLE\)](#) [MIKROPASCAL PRO FOR PIC32 \(USB](#)
[DONGLE LI](#) [SW006021-2H](#) [ATATMELSTUDIO](#) [2400573](#) [2702579](#) [2988609](#) [2702546](#) [SW006022-DGL](#) [2400303](#) [2701356](#) [VDSP-21XX-](#)
[PCFLOAT](#) [VDSP-BLKFN-PC-FULL](#) [88970111](#) [DG-ACC-NET-CD](#) [55195101-102](#) [SW1A-W1C](#) [MDK-ARM](#) [PCI-EXP1-E3-US](#) [PCI-T32-](#)
[E3-US](#) [SW006021-2NH](#) [SW006021-1H](#) [SW006021-2](#)