

2N6764, JANTX2N6764, JANTXV2N6764
 2N6766, JANTX2N6766, JANTXV2N6766

2N6768, JANTX2N6768, JANTXV2N6768
 2N6770, JANTX2N6770, JANTXV2N6770

JANTX, JANTXV POWER MOSFET IN TO-204 PACKAGE, QUALIFIED TO MIL-PRF-19500/543

100V Thru 500V, Up to 38A, N-Channel,
 Enhancement Mode MOSFET Power Transistor

FEATURES

- Low $R_{DS(on)}$
- Ease of Paralleling
- Qualified to MIL-PRF-19500/543



DESCRIPTION

This hermetically packaged QPL product features the latest advanced MOSFET technology. It is ideally suited for Military requirements where small size, high performance and high reliability are required, and in applications such as switching power supplies, motor controls, inverters, choppers, audio amplifiers and high energy pulse circuits.

PRIMARY ELECTRICAL CHARACTERISTICS @ $T_c = 25\text{ C}$

PART NUMBER	V_{DS} , Volts	$R_{DS(on)}$	I_D , Amps
2N6764	100	.055	38
2N6766	200	.085	30
2N6768	400	.30	14
2N6770	500	.40	12

SCHEMATIC

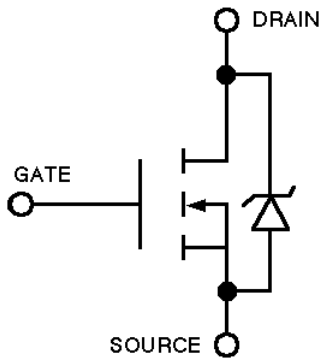

MECHANICAL OUTLINE

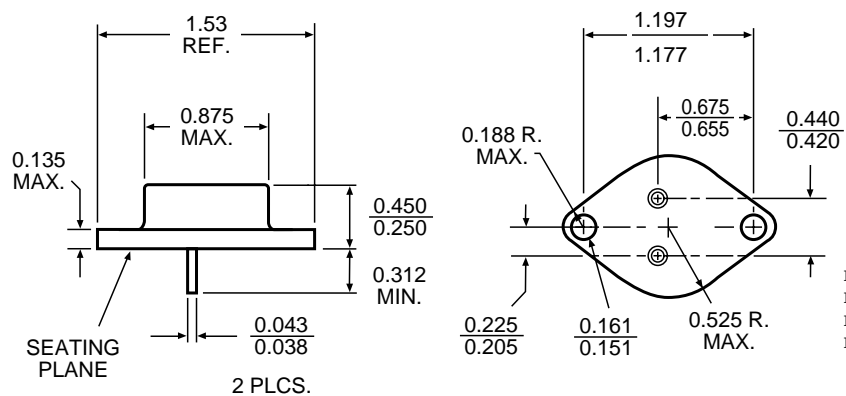

Pin Connection
 Pin 1: Drain
 Pin 2: Source
 Pin 3: Gate

Note: For part number 2N6764 and 2N6766 the mechanical dimensions are the same as above except the lead diameter is 0.058 min to 0.063 max.

2N6764, JANTX2N6764, JANTXV2N6764
2N6766, JANTX2N6766, JANTXV2N6766

2N6768, JANTX2N6768, JANTXV2N6768
2N6770, JANTX2N6770, JANTXV2N6770

ABSOLUTE MAXIMUM RATINGS ($T_C = 25^\circ\text{C}$ unless otherwise noted)

Parameter	JANTXV, JANTX, 2N6764	Units
I_D @ $V_{GS} = 10\text{V}$, $T_C = 25^\circ\text{C}$ Continuous Drain Current	38	A
I_D @ $V_{GS} = 10\text{V}$, $T_C = 100^\circ\text{C}$ Continuous Drain Current	24	A
I_{DM} Pulsed Drain Current ¹	152	A
P_D @ $T_C = 25^\circ\text{C}$ Maximum Power Dissipation	150	W
Linear Derating Factor	1.2	W/ $^\circ\text{C}$
V_{GS} Gate-Source Voltage	± 20	V
E_{AS} Single Pulse Avalanche Energy ²	150 ⁴	mJ
I_{AR} Avalanche Current ¹	38 ⁴	A
T_J Operating Junction	-55 to 150	$^\circ\text{C}$
T_{STG} Storage Temperature Range		$^\circ\text{C}$
Lead Temperature	300(.06 from case for 10 sec)	$^\circ\text{C}$

ELECTRICAL CHARACTERISTICS @ $T_J = 25^\circ\text{C}$ (Unless Otherwise Specified)

Parameter	Min.	Typ.	Max.	Units	Test Conditions
BV_{DSS} Drain-Source Breakdown Voltage	100			V	$V_{GS} = 0\text{V}$, $I_D = 1.0\text{ mA}$,
$R_{DS(on)}$ Static Drain-to-Source On-State Resistance	—	—	0.055		$V_{GS} = 10\text{V}$, $I_D = 24\text{ A}$ ³
	—	—	0.065		$V_{GS} = 10\text{V}$, $I_D = 38\text{ A}$ ³
$V_{GS(th)}$ Gate Threshold Voltage	2.0	—	4.0	V	$V_{DS} = V_{GS}$, $I_D = 250\text{ }\mu\text{A}$
I_{DSS} Zero Gate Voltage Drain Current	—	—	25	μA	$V_{DS} = 80\text{ V}$, $V_{GS} = 0\text{V}$
	—	—	250		$V_{DS} = 80\text{ V}$, $V_{GS} = 0\text{V}$, $T_J = 125^\circ\text{C}$
I_{SS} Gate -to-Source Leakage Forward	—	—	100	nA	$V_{GS} = 20\text{ V}$
I_{SS} Gate -to-Source Leakage Reverse	—	—	-100	nA	$V_{GS} = -20\text{ V}$
$Q_{G(on)}$ On-state Gate Charge	50	—	125	nC	$V_{GS} = 10\text{ V}$, $I_D = 38\text{ A}$
Q_{GS} Gate-to-Source Charge	8	—	22	nC	$V_{DS} = 50\text{ V}$
Q_{GD} Gate-to-Drain ("Miller") Charge	25	—	65	nC	See note 4
t_{ON} Turn-On Delay Time	—	—	35	ns	$V_{DD} = 50\text{ V}$, $I_D = 38\text{ A}$, $R_G = 2.35$
t_r Rise Time	—	—	190	ns	See note 4
t_{OFF} Turn-Off Delay Time	—	—	170	ns	
t_f Fall Time	—	—	130	ns	

Source-Drain Diode Ratings and Characteristics

Parameter	Min.	Typ.	Max.	Units	Test Conditions
V_{SD} Diode Forward Voltage	—	—	1.9	V	$T_J = 25^\circ\text{C}$, $I_S = 38\text{ A}$ ³ , $V_{GS} = 0\text{ V}$
t_r Reverse Recovery Time	—	—	500	ns	$T_J = 25^\circ\text{C}$, $I_S = 38\text{ A}$, $dI/dt \leq 100\text{ A}/\mu\text{s}$ ³

Thermal Resistance

Parameter	Min.	Typ.	Max.	Units	Test Conditions
R_{thJC} Junction-to-Case	—	—	0.83	$^\circ\text{C}/\text{W}$	Mounting surface flat, smooth, and greased
R_{thCS} Case-to-sink	—	0.21	—		
R_{thJA} Junction-to-Ambient	—	—	48		

1. Repetitive Rating: Pulse width limited by maximum junction temperature.
2. @ $V_{DD} = 50\text{V}$, Starting $T_J = 25^\circ\text{C}$, $L = 100\text{ }\mu\text{H} \pm 10\%$, $R_G = 25$, Peak $I_L = 38\text{A}$
3. Pulse width $\leq 300\text{ }\mu\text{s}$; Duty Cycle $\leq 2\%$
4. See MIL-S-19500/543

2N6764, JANTX2N6764, JANTXV2N6764
2N6766, JANTX2N6766, JANTXV2N6766

2N6768, JANTX2N6768, JANTXV2N6768
2N6770, JANTX2N6770, JANTXV2N6770

ABSOLUTE MAXIMUM RATINGS ($T_C = 25^\circ\text{C}$ unless otherwise noted)

Parameter	JANTXV, JANIX, 2N6766	Units
I_D @ $V_{GS} = 10\text{V}$, $T_C = 25^\circ\text{C}$ Continuous Drain Current	30	A
I_D @ $V_{GS} = 10\text{V}$, $T_C = 100^\circ\text{C}$ Continuous Drain Current	19	A
I_{DM} Pulsed Drain Current ¹	120	A
P_D @ $T_C = 25^\circ\text{C}$ Maximum Power Dissipation	150	W
Linear Derating Factor	1.2	W/ $^\circ\text{C}$
V_{GS} Gate-Source Voltage	± 20	V
E_{AS} Single Pulse Avalanche Energy ²	60 ⁴	mJ
I_{AR} Avalanche Current ¹	30 ⁴	A
T_J Operating Junction	-55 to 150	$^\circ\text{C}$
T_{STG} Storage Temperature Range		$^\circ\text{C}$
Lead Temperature	300(.06 from case for 10 sec)	$^\circ\text{C}$

ELECTRICAL CHARACTERISTICS @ $T_J = 25^\circ\text{C}$ (Unless Otherwise Specified)

Parameter	Min.	Typ.	Max.	Units	Test Conditions
BV_{DSS} Drain-Source Breakdown Voltage	200			V	$V_{GS} = 0\text{V}$, $I_D = 1.0\text{ mA}$,
$R_{DS(on)}$ Static Drain-to-Source On-State Resistance	—	—	.085		$V_{GS} = 10\text{ V}$, $I_D = 19\text{ A}$ ³
	—	—	.090		$V_{GS} = 10\text{ V}$, $I_D = 30\text{ A}$ ³
$V_{GS(th)}$ Gate Threshold Voltage	2.0	—	4.0	V	$V_{DS} = V_{GS}$, $I_D = 250\text{ }\mu\text{A}$
I_{SS} Zero Gate Voltage Drain Current	—	—	25	μA	$V_{DS} = 160\text{ V}$, $V_{GS} = 0\text{ V}$
	—	—	250		$V_{DS} = 160\text{ V}$, $V_{GS} = 0\text{ V}$, $T_J = 125^\circ\text{C}$
I_{SS} Gate -to-Source Leakage Forward	—	—	100	nA	$V_{GS} = 20\text{ V}$
I_{SS} Gate -to-Source Leakage Reverse	—	—	-100	nA	$V_{GS} = -20\text{ V}$
$Q_{G(on)}$ On-state Gate Charge	55	—	115	nC	$V_{GS} = 10\text{ V}$, $I_D = 30\text{ A}$
Q_{GS} Gate-to-Source Charge	8	—	22	nC	$V_{DS} = 100\text{ V}$
Q_{GD} Gate-to-Drain ("Miller") Charge	30	—	60	nC	See note 4
$t_{(on)}$ Turn-On Delay Time	—	—	35	ns	$V_{DD} = 100\text{ V}$, $I_D = 30\text{ A}$, $R_G = 2.35$ See note 4
t_r Rise Time	—	—	190	ns	
$t_{(off)}$ Turn-Off Delay Time	—	—	170	ns	
t_f Fall Time	—	—	130	ns	

Source-Drain Diode Ratings and Characteristics

Parameter	Min.	Typ.	Max.	Units	Test Conditions
V_{SD} Diode Forward Voltage	—	—	1.9	V	$T_J = 25^\circ\text{C}$, $I_F = 30\text{ A}$ ³ , $V_{GS} = 0\text{ V}$
t_r Reverse Recovery Time	—	—	950	ns	$T_J = 25^\circ\text{C}$, $I_F = 30\text{ A}$, $dI/dt < 100\text{ A}/\mu\text{s}$ ³

Thermal Resistance

Parameter	Min.	Typ.	Max.	Units	Test Conditions
R_{thJC} Junction-to-Case	—	—	0.83	$^\circ\text{C}/\text{W}$	Mounting surface flat, smooth, and greased
R_{thCS} Case-to-sink	—	0.21	—		
R_{thJA} Junction-to-Ambient	—	—	48		

1. Repetitive Rating: Pulse width limited by maximum junction temperature.
2. @ $V_{DD} = 50\text{ V}$, Starting $T_J = 25^\circ\text{C}$, $L = 100\text{ }\mu\text{H} \pm 10\%$, $R_G = 25$, Peak $I_L = 30\text{ A}$
3. Pulse width $\leq 300\text{ }\mu\text{s}$; Duty Cycle $\leq 2\%$
4. See MIL-S-19500/543

2N6764, JAN1X2N6764, JAN1XV2N6764
2N6766, JAN1X2N6766, JAN1XV2N6766

2N6768, JAN1X2N6768, JAN1XV2N6768
2N6770, JAN1X2N6770, JAN1XV2N6770

ABSOLUTE MAXIMUM RATINGS ($T_C = 25^\circ\text{C}$ unless otherwise noted)

Parameter	JAN1XV, JAN1X, 2N6768	Units
I_D @ $V_{GS} = 10\text{V}$, $T_C = 25^\circ\text{C}$ Continuous Drain Current	14	A
I_D @ $V_{GS} = 10\text{V}$, $T_C = 100^\circ\text{C}$ Continuous Drain Current	9.0	A
I_{DM} Pulsed Drain Current ¹	56	A
P_D @ $T_C = 25^\circ\text{C}$ Maximum Power Dissipation	150	W
Linear Derating Factor	1.2	W/ $^\circ\text{C}$
V_{GS} Gate-Source Voltage	± 20	V
E_{AS} Single Pulse Avalanche Energy ²	11.3 ⁴	mJ
I_{AR} Avalanche Current ¹	14 ⁴	A
T_J Operating Junction	-55 to 150	$^\circ\text{C}$
T_{STG} Storage Temperature Range		$^\circ\text{C}$
Lead Temperature	300(.06 from case for 10 sec)	$^\circ\text{C}$

ELECTRICAL CHARACTERISTICS @ $T_J = 25^\circ\text{C}$ (Unless Otherwise Specified)

Parameter	Min.	Typ.	Max.	Units	Test Conditions
BV_{DSS} Drain-Source Breakdown Voltage	400			V	$V_{GS} = 0\text{V}$, $I_D = 1.0\text{ mA}$,
$R_{DS(on)}$ Static Drain-to-Source On-State Resistance	—	—	.300		$V_{GS} = 10\text{V}$, $I_D = 9.0\text{ A}$ ³
	—	—	.400		$V_{GS} = 10\text{V}$, $I_D = 14\text{ A}$ ³
$V_{GS(th)}$ Gate Threshold Voltage	2.0	—	4.0	V	$V_{GS} = V_{GS} = I_D = 250\text{ }\mu\text{A}$
I_{DSS} Zero Gate Voltage Drain Current	—	—	25	μA	$V_{DS} = 320\text{ V}$, $V_{GS} = 0\text{V}$
	—	—	250	μA	$V_{DS} = 320\text{ V}$, $V_{GS} = 0\text{V}$, $T_J = 125^\circ\text{C}$
I_{SS} Gate -to-Source Leakage Forward	—	—	100	nA	$V_{GS} = 20\text{ V}$
I_{SS} Gate -to-Source Leakage Reverse	—	—	-100	nA	$V_{GS} = -20\text{ V}$
$Q_{G(on)}$ On-state Gate Charge	52	—	110	nC	$V_{GS} = 10\text{ V}$, $I_D = 14\text{ A}$
Q_{GS} Gate-to-Source Charge	5.0	—	18	nC	$V_{DS} = 200\text{ V}$
Q_{GD} Gate-to-Drain ("Miller") Charge	25	—	65	nC	See note 4
t_{on} Turn-On Delay Time	—	—	35	ns	$V_{DD} = 200\text{ V}$, $I_D = 14\text{ A}$, $R_G = 2.35$
t_r Rise Time	—	—	190	ns	See note 4
t_{off} Turn-Off Delay Time	—	—	170	ns	
t_f Fall Time	—	—	130	ns	

Source-Drain Diode Ratings and Characteristics

Parameter	Min.	Typ.	Max.	Units	Test Conditions
V_{SD} Diode Forward Voltage	—	—	1.7	V	$T_J = 25^\circ\text{C}$, $I_S = 14\text{ A}$ ³ , $V_{GS} = 0\text{ V}$
t_r Reverse Recovery Time	—	—	1200	ns	$T_J = 25^\circ\text{C}$, $I_S = 14\text{ A}$, $dI/dt \leq 100\text{ A}/\mu\text{s}$ ³

Thermal Resistance

Parameter	Min.	Typ.	Max.	Units	Test Conditions
R_{thJC} Junction-to-Case	—	—	0.83	$^\circ\text{C}/\text{W}$	Mounting surface flat, smooth, and greased
R_{thCS} Case-to-sink	—	0.21	—		
R_{thJA} Junction-to-Ambient	—	—	48		

1. Repetitive Rating: Pulse width limited by maximum junction temperature.
2. @ $V_{DD} = 50\text{ V}$, Starting $T_J = 25^\circ\text{C}$, $L = 100\text{ }\mu\text{H} \pm 10\%$, $R_G = 25$, Peak $I_L = 14\text{ A}$
3. Pulse width $\leq 300\text{ }\mu\text{s}$; Duty Cycle $\leq 2\%$
4. See MIL-S-19500/543

2N6764, JANTX2N6764, JANTXV2N6764
2N6766, JANTX2N6766, JANTXV2N6766

2N6768, JANTX2N6768, JANTXV2N6768
2N6770, JANTX2N6770, JANTXV2N6770

ABSOLUTE MAXIMUM RATINGS ($T_C = 25^\circ\text{C}$ unless otherwise noted)

Parameter	JANIXV, JANIX, 2N6770	Units
I_D @ $V_{GS} = 10\text{V}$, $T_C = 25^\circ\text{C}$ Continuous Drain Current	12	A
I_D @ $V_{GS} = 10\text{V}$, $T_C = 100^\circ\text{C}$ Continuous Drain Current	7.75	A
I_{DM} Pulsed Drain Current ¹	48	A
P_D @ $T_C = 25^\circ\text{C}$ Maximum Power Dissipation	150	W
Linear Derating Factor	1.2	W/ $^\circ\text{C}$
V_{GS} Gate-Source Voltage	± 20	V
E_{AS} Single Pulse Avalanche Energy ²	8.0 ⁴	mJ
I_{AR} Avalanche Current ¹	12 ⁴	A
T_J Operating Junction	-55 to 150	$^\circ\text{C}$
T_{STG} Storage Temperature Range		$^\circ\text{C}$
Lead Temperature	300(.06 from case for 10 sec)	$^\circ\text{C}$

ELECTRICAL CHARACTERISTICS @ $T_J = 25^\circ\text{C}$ (Unless Otherwise Specified)

Parameter	Min.	Typ.	Max.	Units	Test Conditions
BV_{DSS} Drain-Source Breakdown Voltage	500			V	$V_{GS} = 0\text{V}$, $I_D = 1.0\text{ mA}$,
$R_{DS(on)}$ Static Drain-to-Source On-State Resistance	—	—	.400		$V_{GS} = 10\text{V}$, $I_D = 7.75\text{ A}$ ³
	—	—	.500		$V_{GS} = 10\text{V}$, $I_D = 12\text{ A}$ ³
$V_{GS(th)}$ Gate Threshold Voltage	2.0	—	4.0	V	$V_{DS} = V_{GS}$, $I_D = 250\text{ }\mu\text{A}$
I_{DSS} Zero Gate Voltage Drain Current	—	—	25	μA	$V_{DS} = 400\text{ V}$, $V_{GS} = 0\text{V}$
	—	—	250		$V_{DS} = 400\text{V}$, $V_{GS} = 0\text{V}$, $T_J = 125^\circ\text{C}$
I_{SS} Gate -to-Source Leakage Forward	—	—	100	nA	$V_{GS} = 20\text{ V}$
I_{SS} Gate -to-Source Leakage Reverse	—	—	-100	nA	$V_{GS} = -20\text{ V}$
$Q_{G(on)}$ On-state Gate Charge	55	—	120	nC	$V_{GS} = 10\text{ V}$, $I_D = 12\text{ A}$
Q_{GS} Gate-to-Source Charge	5.0	—	19	nC	$V_{DS} = 250\text{ V}$
Q_{GD} Gate-to-Drain ("Miller") Charge	27	—	70	nC	See note 4
$t_{p(on)}$ Turn-On Delay Time	—	—	35	ns	$V_{DD} = 250\text{ V}$, $I_D = 12\text{ A}$, $R_G = 2.35$
t_r Rise Time	—	—	190	ns	See note 4
$t_{p(off)}$ Turn-Off Delay Time	—	—	170	ns	
t_f Fall Time	—	—	130	ns	

Source-Drain Diode Ratings and Characteristics

Parameter	Min.	Typ.	Max.	Units	Test Conditions
V_{SD} Diode Forward Voltage	—	—	1.7	V	$T_J = 25^\circ\text{C}$, $I_S = 12\text{ A}$ ³ , $V_{GS} = 0\text{ V}$
t_r Reverse Recovery Time	—	—	1600	ns	$T_J = 25^\circ\text{C}$, $I_F = 12\text{A}$, $dI/dt \leq 100\text{A}/\mu\text{s}$ ³

Thermal Resistance

Parameter	Min.	Typ.	Max.	Units	Test Conditions
R_{thJC} Junction-to-Case	—	—	0.83	$^\circ\text{C}/\text{W}$	Mounting surface flat, smooth, and greased
R_{thCS} Case-to-sink	—	0.21	—		
R_{thJA} Junction-to-Ambient	—	—	48		

1. Repetitive Rating: Pulse width limited by maximum junction temperature.
2. @ $V_{DD} = 50\text{ V}$, Starting $T_J = 25^\circ\text{C}$, $L = 100\text{ }\mu\text{H} \pm 10\%$, $R_G = 25$, Peak $I_L = 12\text{ A}$
3. Pulse width $\leq 300\text{ }\mu\text{s}$; Duty Cycle $\leq 2\%$
4. See MIL-S-19500/543

X-ON Electronics

Largest Supplier of Electrical and Electronic Components

Click to view similar products for [MOSFET](#) category:

Click to view products by [International Rectifier](#) manufacturer:

Other Similar products are found below :

[614233C](#) [648584F](#) [MCH3443-TL-E](#) [MCH6422-TL-E](#) [FDPF9N50NZ](#) [FW216A-TL-2W](#) [FW231A-TL-E](#) [APT5010JVR](#) [NTNS3A92PZT5G](#)
[IRF100S201](#) [JANTX2N5237](#) [2SK2464-TL-E](#) [2SK3818-DL-E](#) [FCA20N60_F109](#) [FDZ595PZ](#) [STD6600NT4G](#) [FSS804-TL-E](#) [2SJ277-DL-E](#)
[2SK1691-DL-E](#) [2SK2545\(Q,T\)](#) [D2294UK](#) [405094E](#) [423220D](#) [MCH6646-TL-E](#) [TPCC8103,L1Q\(CM](#) [367-8430-0972-503](#) [VN1206L](#)
[424134F](#) [026935X](#) [051075F](#) [SBVS138LT1G](#) [614234A](#) [715780A](#) [NTNS3166NZT5G](#) [751625C](#) [873612G](#) [IRF7380TRHR](#)
[IPS70R2K0CEAKMA1](#) [RJK60S3DPP-E0#T2](#) [RJK60S5DPK-M0#T0](#) [APT5010JVFR](#) [APT12031JFLL](#) [APT12040JVR](#) [DMN3404LQ-7](#)
[NTE6400](#) [JANTX2N6796U](#) [JANTX2N6784U](#) [JANTXV2N5416U4](#) [SQM110N05-06L-GE3](#) [SIHF35N60E-GE3](#)