

IV1D12040U3Z – 1200V 40A Automotive SiC Schottky Diode

Features

- Max Junction Temperature 175°C
- High Surge Current Capacity
- Zero Reverse Recovery Current
- Zero Forward Recovery Voltage
- High-Frequency Operation
- Temperature independent switching behavior
- Positive Temperature Coefficient on V_F
- AEC-Q101 qualified

Outline

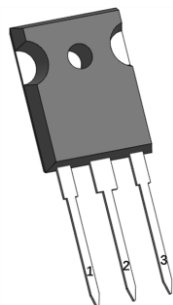

TO247-3

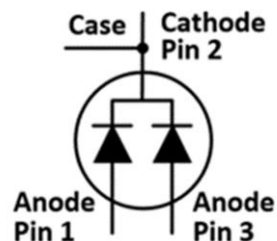

Applications

- Automotive Inverter Free Wheeling Diodes
- EV Charger Piles
- Vienna 3-Phase PFC
- Solar Power Boost
- Switch Mode Power Supplies

Marking Diagram

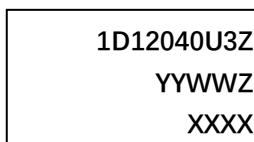

1D12040U3Z=Specific Device Code
 YY =Year
 WW =Work Week
 Z =Assembly Location
 XXXX =Lot Traceability

Absolute Maximum Ratings (Tc=25°C unless otherwise specified)

Symbol	Parameter	Value	Unit
V_{RRM}	Reverse voltage (repetitive peak)	1200	V
V_{DC}	DC blocking voltage	1200	V
I_F	Forward current (continuous) @Tc=25°C	54*	A
	Forward current (continuous) @Tc=135°C	28*	A
	Forward current (continuous) @Tc=151°C	20*	A
I_{FSM}	Surge non-repetitive forward current sine halfwave @Tc=25°C tp=10ms	140*	A
I_{FRM}	Surge repetitive forward current (Freq=0.1Hz, 100cycles) sine halfwave @Tamb=25°C tp=10ms	115*	A
P_{tot}	Total power dissipation @ Tc=25°C	272*	W
	Total power dissipation @ Tc=150°C	45*	
$\int i^2 dt$	I^2t value @Tc=25°C tp=10ms	98*	A ² s
Tstg	Storage temperature range	-55 to 175	°C
Tj	Operating junction temperature range	-55 to 175	°C

*Per Leg

Stresses exceeding those listed in the Maximum Ratings table may damage the device. If any of these limits are exceeded, device functionality should not be assumed, damage may occur and reliability may be affected.

Electrical Characteristics

Symbol	Parameter	Typ.	Max.	Unit	Test Conditions	Note
V _F	Forward Voltage	1.48*	1.8*	V	I _F = 20 A T _J =25°C	Fig. 1
		2.1*	3.0*		I _F = 20 A T _J =175°C	
I _R	Reverse Current	10*	200*	μA	V _R = 1200 V T _J =25°C	Fig. 2
		45*	800*		V _R = 1200 V T _J =175°C	
C	Total Capacitance	1114*		pF	V _R = 1 V, T _J = 25°C, f = 1 MHz	Fig. 3
		100*			V _R = 400 V, T _J = 25°C, f = 1 MHz	
		77*			V _R = 800 V, T _J = 25°C, f = 1 MHz	
Q _C	Total Capacitive Charge	107*		nC	V _R = 800 V, T _J = 25°C, $Q_C = \int_0^{V_R} C(V) dV$	Fig. 4
E _C	Capacitance Stored Energy	31*		μJ	V _R = 800 V, T _J = 25°C, $E_C = \int_0^{V_R} C(V) \cdot V dV$	Fig. 5

*Per Leg

Thermal Characteristics (Per Leg)

Symbol	Parameter	Typ.	Unit	Note
R _{th(j-c)}	Thermal Resistance from Junction to Case	0.55	°C/W	Fig.7

Typical Performance (Per Leg)

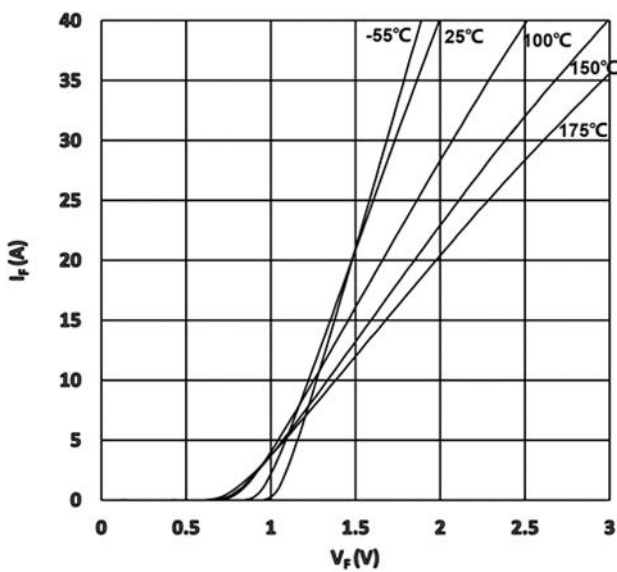

Figure 1. Typical Forward Characteristics

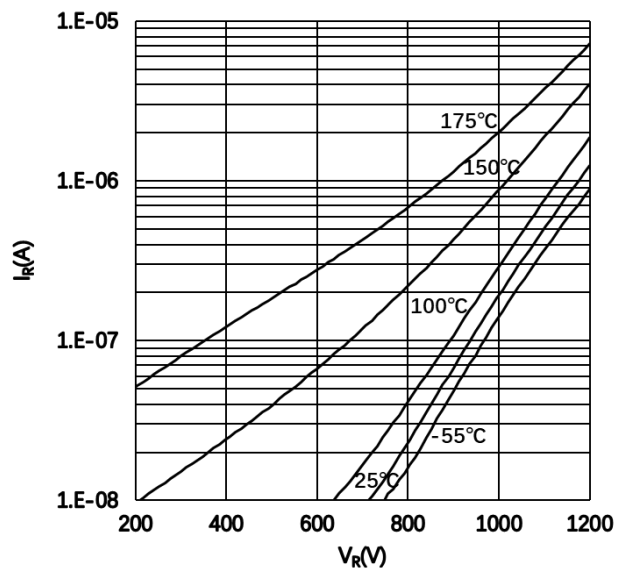

Figure 2. Typical Reverse Characteristics

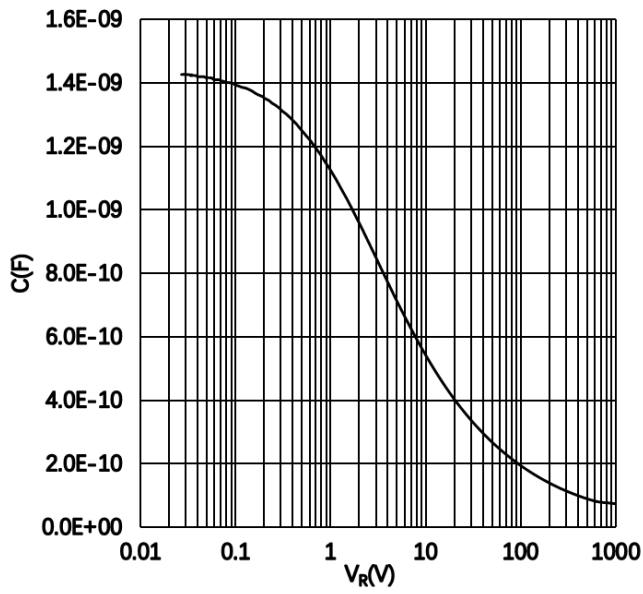

Figure 3. Capacitance vs. Reverse Voltage

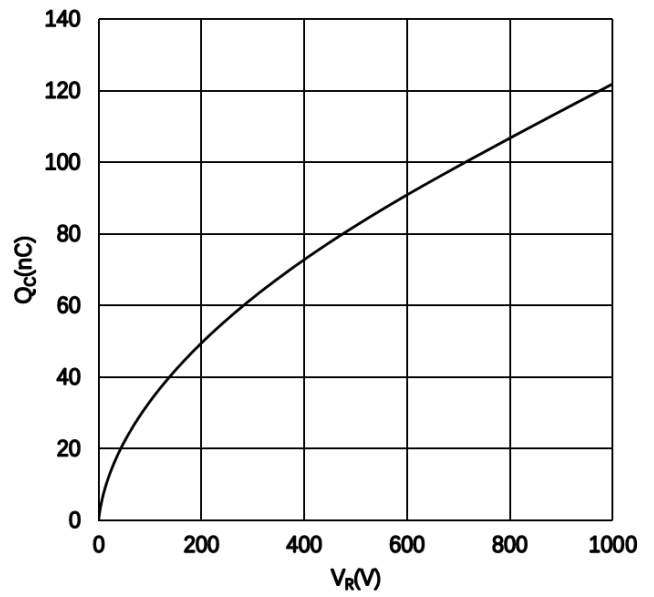

Figure 4. Recovery Charge vs. Reverse Voltage

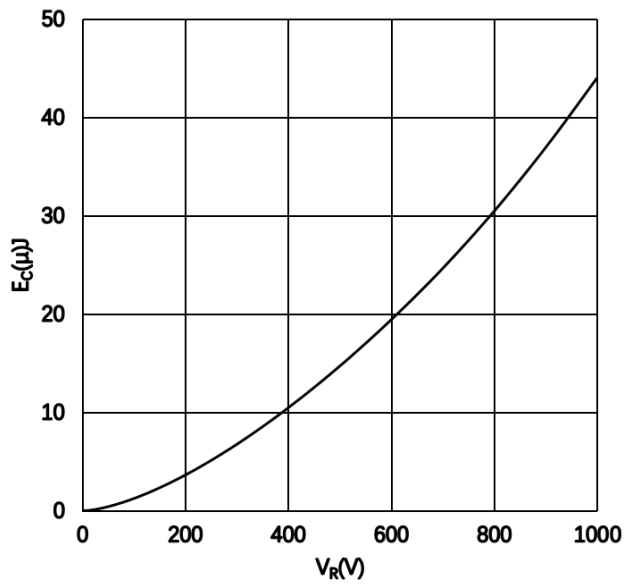

Figure 5. Capacitance Stored Energy

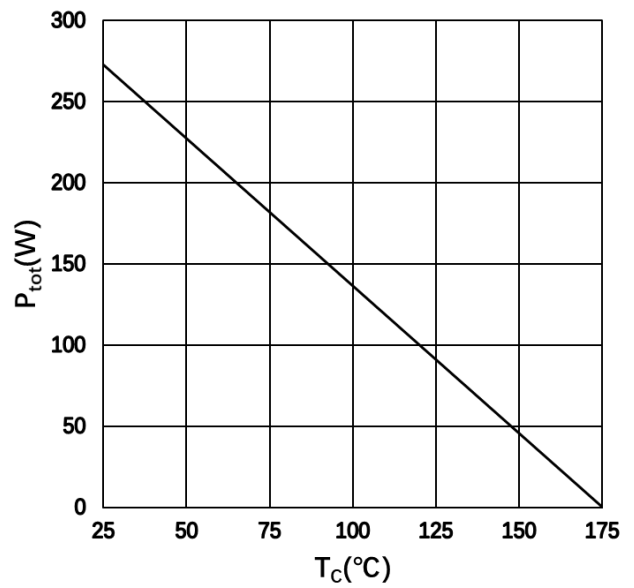

Figure 6. Power Derating

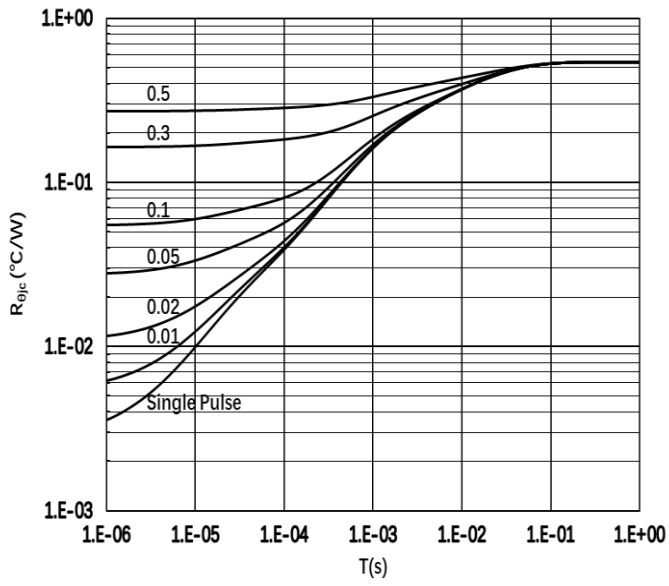

Figure 7. Transient Thermal Impedance

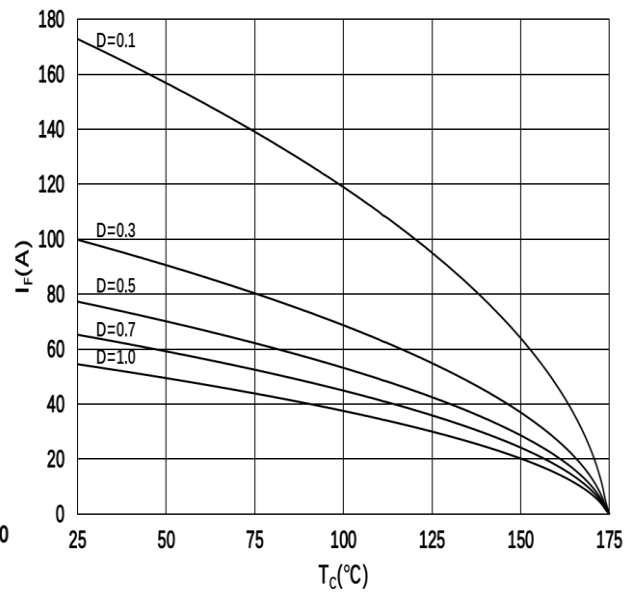
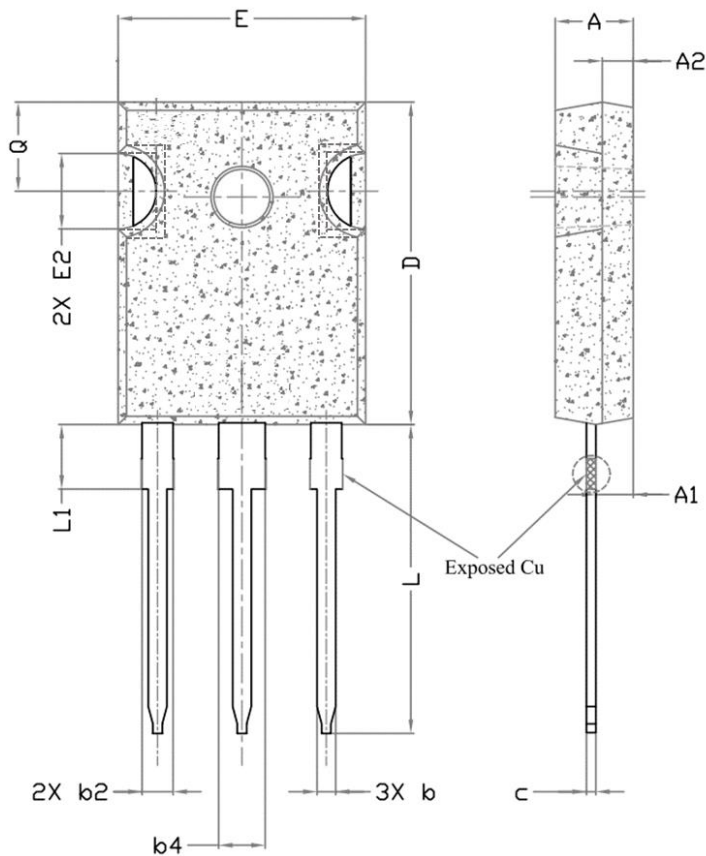
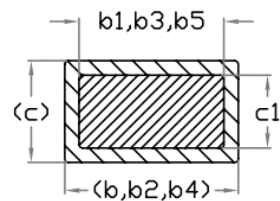
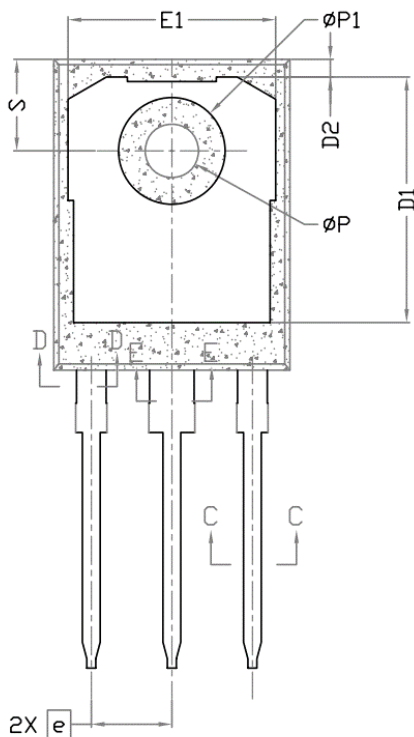

Figure 8. Forward Current as a Function of Temp.

Package Dimensions



Dimensions In Millimeters		
SYMBOL	MIN.	MAX.
A	4.83	5.21
A1	2.29	2.55
A2	1.50	2.49
b	1.07	1.33
b1	1.07	1.28
b2	1.91	2.41
b3	1.91	2.34
b4	2.87	3.38
b5	2.87	3.18
c	0.55	0.69
c1	0.55	0.65
D	20.80	21.10
D1	16.25	17.65
D2	0.51	1.35
E	15.70	16.13
E1	13.10	14.16
E2	3.68	5.49
e	5.44 BSC	
L	19.80	20.32
L1	3.95	4.40
Ø P	3.50	3.70
Ø P1	7.00	7.40
Q	5.39	6.20
S	6.04	6.30



Section C--C,D--D,E--E

Note:

1. Package Reference: JEDEC TO247, Variation AD
2. All Dimensions are in mm
3. Slot Required, Notch May Be Rounded or Rectangular
4. Dimension D&E Do Not Include Mold Flash
5. Subject to Change Without Notice

Notes

For further information please contact IVCT's Sales Office.

Copyright©2022 InventChip Technology Co., Ltd. All rights reserved.

The information in this document is subject to change without notice.

Related Links

<http://www.inventchip.com.cn>



X-ON Electronics

Largest Supplier of Electrical and Electronic Components

Click to view similar products for [Schottky Diodes & Rectifiers](#) category:

Click to view products by [InventChip](#) manufacturer:

Other Similar products are found below :

[MA4E2039](#) [MMBD301M3T5G](#) [HFA35HB60C](#) [RB160M-50TR](#) [D83C](#) [BAS16E6433HTMA1](#) [BAS 3010S-02LRH](#) [E6327](#) [BAT 54-02LRH](#)
[E6327](#) [NRVBAF360T3G](#) [NSR05F40QNXT5G](#) [NTE555](#) [JANS1N6640](#) [SS3003CH-TL-E](#) [GA01SHT18](#) [CRS10I30A\(TE85L,QM](#)
[MBRA140TRPBF](#) [MBRB30H30CT-1G](#) [BAT 15-04R](#) [E6152](#) [JANTX1N5712-1](#) [DMJ3940-000](#) [SB007-03C-TB-E](#) [NRVBB20100CTT4G](#)
[NRVBM120LT1G](#) [NTSB30U100CT-1G](#) [CRG04\(T5L,TEMQ\)](#) [ACDBA1100LR-HF](#) [ACDBA1200-HF](#) [ACDBA240-HF](#) [ACDBA3100-HF](#)
[CDBQC0530L-HF](#) [ACDBA260LR-HF](#) [ACDBA1100-HF](#) [10BQ015-M3/5BT](#) [NRVBM120ET1G](#) [VSSB410S-M3/5BT](#) [1N5819T-G](#)
[PDS1040Q-13](#) [B160BQ-13-F](#) [SDM05U20CSP-7](#) [BAS 70-07](#) [E6433](#) [B140S1F-7](#) [HSM560Je3/TR13](#) [DDB2265-000](#) [ZHCS506QTA](#)
[HSM190Je3/TR13](#) [B330AF-13](#) [ACDBUC0230-HF](#) [SDM1U100S1F-7](#) [MBR10200CTF-G1](#) [CDLL5712](#)