

# ANTDOM-XX-CT-WPM GPS ANTENNA

## Functional Specification



---

Inventek Systems, LLC  
239 Littleton Road, Suite 4D  
Westford, Massachusetts 01886  
978-392-2202

© 2008 Inventek Systems, LLC  
239 Littleton Road, Suite 4D  
Westford, Massachusetts 01886  
978-392-2202  
978-692-3502 (Fax)

Visit us at <http://www.inventeksys.com/>

Inventek Systems, LLC, reserves the right to make changes to its products, specifications and other information at any time without notice. Inventek Systems assumes no liability or responsibility for any claims or damages arising out of the use of this document, or from the use of products based on this document, including, but not limited to claims or damages based on infringement of patents, copyrights or other intellectual property rights. Inventek Systems makes no warranties, either express or implied with respect to the information and specifications contained in this document. Performance characteristics listed in this document do not constitute a warranty or guarantee of product performance.

## Contents

Contents .....	3
Overview.....	4
Mechanical .....	5
Thermal.....	5
Power .....	6
Patch Characteristics.....	7
LNA Characteristics.....	7
Far field amplitude excluding the LNA gain.....	8
Shipping.....	9
Ordering Information .....	10
ANTDOM-10-MMCX-WPM Specification .....	11
Figure 1 ANTDOM Dimensions (Inches) .....	5
Table 1 Mechanical.....	5
Table 2 Antenna Temperature .....	5
Table 3 Power Requirements .....	6
Table 4 Filer out of Band .....	7
Table 5 Shipping specification .....	9

## Overview

Inventek's GPS antenna , part number, ANTDOM-XX-CT-WPM is designed to work with a variety of GPS receivers. The active antenna is waterproof and can be used in a variety of applications including automotive with an impedance of 50 ohms.

The Antenna , P/N ANTDOM-XX-CT-WPM lets you integrate GPS functionality into your product quickly and easily. It's suitable for a wide range of applications, including the most compact:

- Hand-held personal positioning and navigation
- External PDAs, Pocket PCs and other hand-held computers
- Fleet management
- Asset tracking
- Automatic vehicle location

The ANTDOM-XX-CT-WPM world class performance suits it to navigating urban canyons, as well as wide-open spaces. Being lead-free, it complies with the European Union's RoHS (Restriction of Hazardous Substances) directive.

## Mechanical

Table 1 summarizes the dimensions of the Antenna.

Parameter	Value
Circular	45 x 45 mm
Width	14.5±0.1 mm
Color	Black
Weight	110 ± 10G including 5 Meter cable
Ohms	50
Pull Strength	6 Kg

Table 1 Mechanical

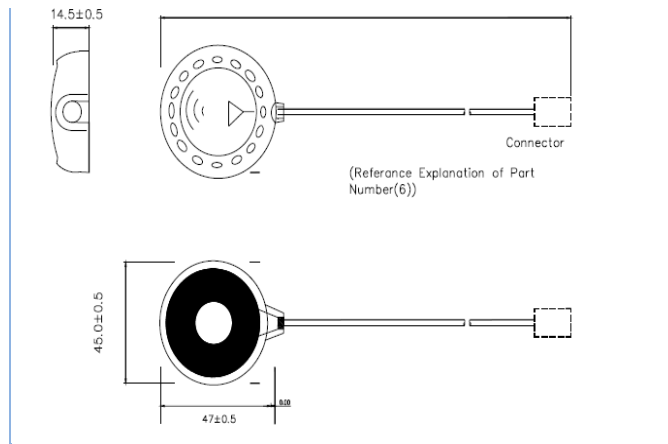

Figure 1 ANTDOM Dimensions (Inches)

## Thermal

Name	
Temperature range	40 to +90 °C
Waterproof	Yes, per IP67 Standard

Table 2 Antenna Temperature

## Power

Table 3 summarizes the Antenna's power requirements.

Parameter	Value
VCC	2.7–5.v V dc
Continuous tracking	10 ma @ 3 Volts

**Table 3 Power Requirements**

You can reduce power consumption by turning on the antenna and only when needed to acquire a fix.

## Patch Characteristics

The Patch characteristics are measured with 70x70 mm ground plane in an anechoic chamber. Active antenna ESD test (working): >16kv (contact discharge with radome)

Patch	Value
Center Frequency	575.42 +/- 1.023 Mhz (with radome and measured by LNA ground plane)
Bandwidth (10 dB return loss)	10 Mhz min
Gain at Zenith	-5.0 dBic typical
Gain at 10 degrees elevation	-1.0 dBic min
Polarization	R.H.C.P
Axial Ratio	1.0 dB Typical

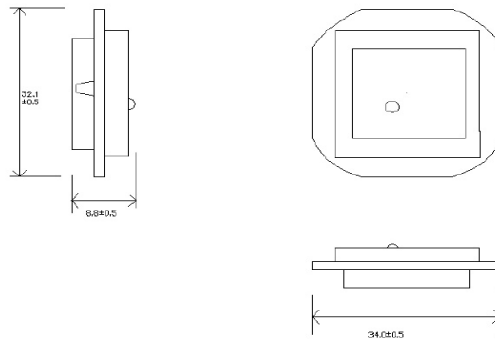

Figure 6 Patch Size

## LNA Characteristics

LNA	Value
Gain	26 to 35 dB ( @ 3volts 30 dB)
Noise figure	1.4 dB Typical (@ 3 volts 1.35dB)
VSWR	DC= 2.0 max

Saw Filter Out of Band	fo
7 db min	fo ± 20 MHz
20 db min	fo ± 50 MHz
20 db min	fo ± 50 MHz

Table 4 Filer out of Band

## Far field amplitude excluding the LNA gain

Here is an example of Radiation Pattern (Exclude LNA Gain) (90°) Far field amplitude excluding the LNA gain

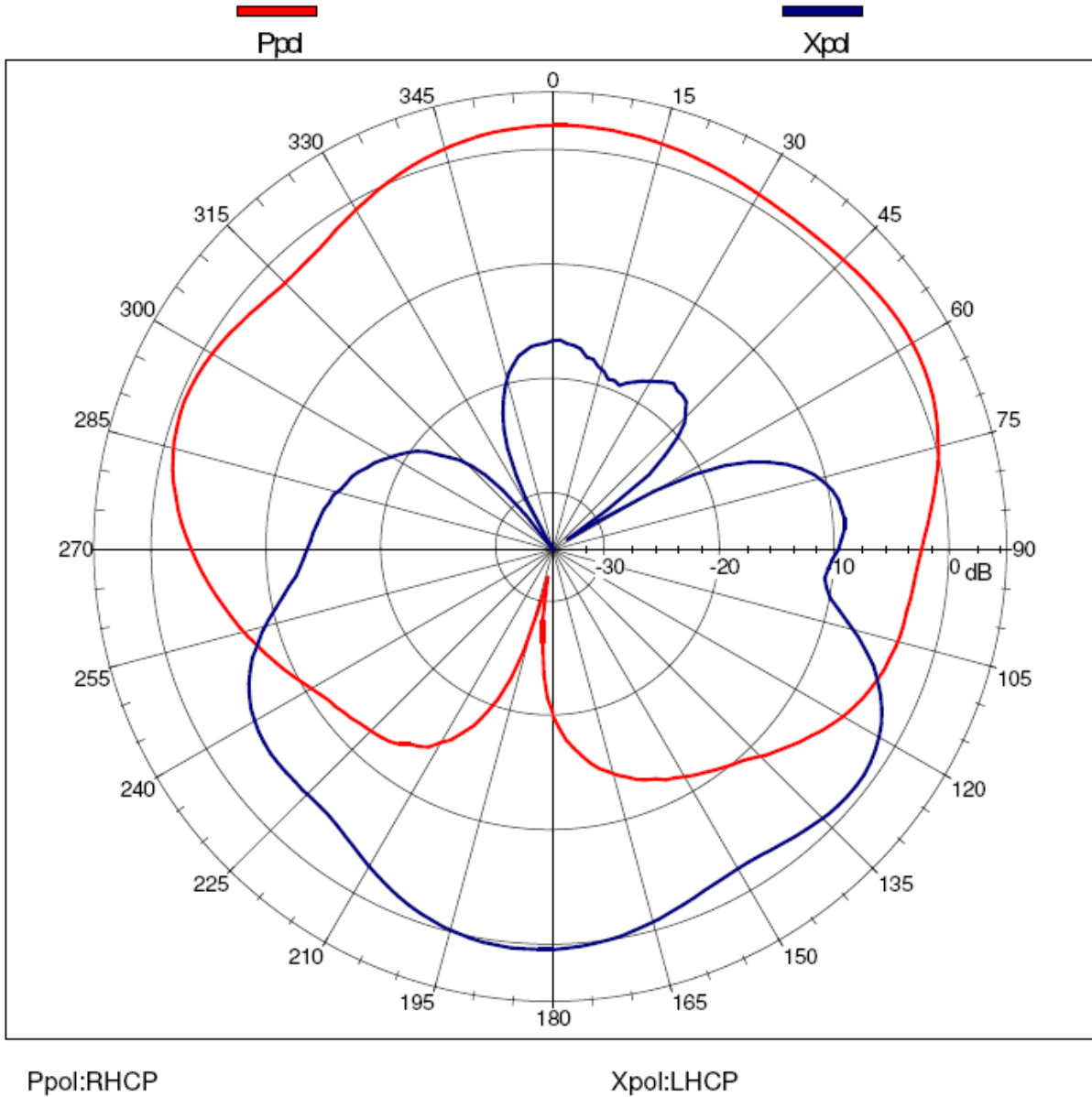
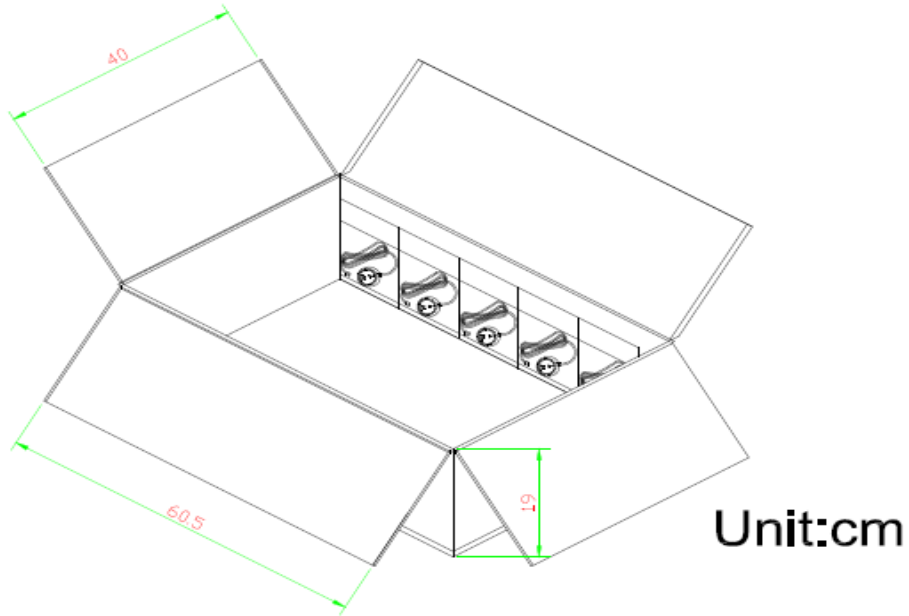

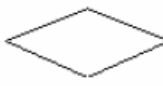

Figure 3 [Radiation Pattern \(Exclude LNA Gain\) \(90°\)](#)



## Shipping

- Each antenna is individually packaged in Plastic bags
- All bags are sealed, impulse sealer
- 100 units per box
- All material and components are ROHS compliance



605		400		
				200
 C/NO.	ITEM NO. QTY: PCS. N.W.: KGS. G.W.: KGS. GUFT:1.2	 C/NO.	ITEM NO. QTY: PCS. N.W.: KGS. G.W.: KGS. GUFT:1.2	190
				200

Tolerances: X=+/-10mm

unit:mm

Table 5 Shipping specification

## Ordering Information

The Antenn is RoHS-compliant and you can custom configure the cable length, type and connector type. Min orders are required for custom builds. Please specify the corresponding part number when ordering.

Build a part number:

The following ordering configurations are available by order:

P/N: ANTDOM-XX-CT-WPM

(XX) = Cable length 05: 5 Meters , 10: 10 Meters , xx: Custom length in meters

(CT) = Connector Types

00 : No connector

01: SMA plug (Male) (standard)

02: SMA jack (Female)

xxx: Custom connector

Ordering Part number sequence example (WP = Waterproof) (M= Magnetic)

ANTDOM-05-01-WPM (5 meter cable with Male SMA, waterproof & magnet)

NTDOM-05-01-WP (5 meter cable with Male SMA, waterproof & no magnet)

Standard Parts:

Part No.	Antenna Type	Connector Type	Cable Length	Magnetic
ANTDOM-05-01-WPM	Active Dome	Male SMA	5 Meter	Yes
ANTDOM-05-01-WP	Active Dome	Male SMA	5 Meter	No
ANTDOM-10-MMCX-WPM	Active Dome	Male MCX	10 Meter	Yes

# ANTDOM-10-MMCX-WPM Specification

The Antennas is RoHS-compliant and you can custom configure the cable length, type and connector type. Min orders are required for custom builds. Please specify the corresponding part number when ordering.

## **MMCX ACTIVE PATCH**

GPS Active Dome Antenna , MMCX, 10 M RG-174 cable, Waterproof and magnetic bottom

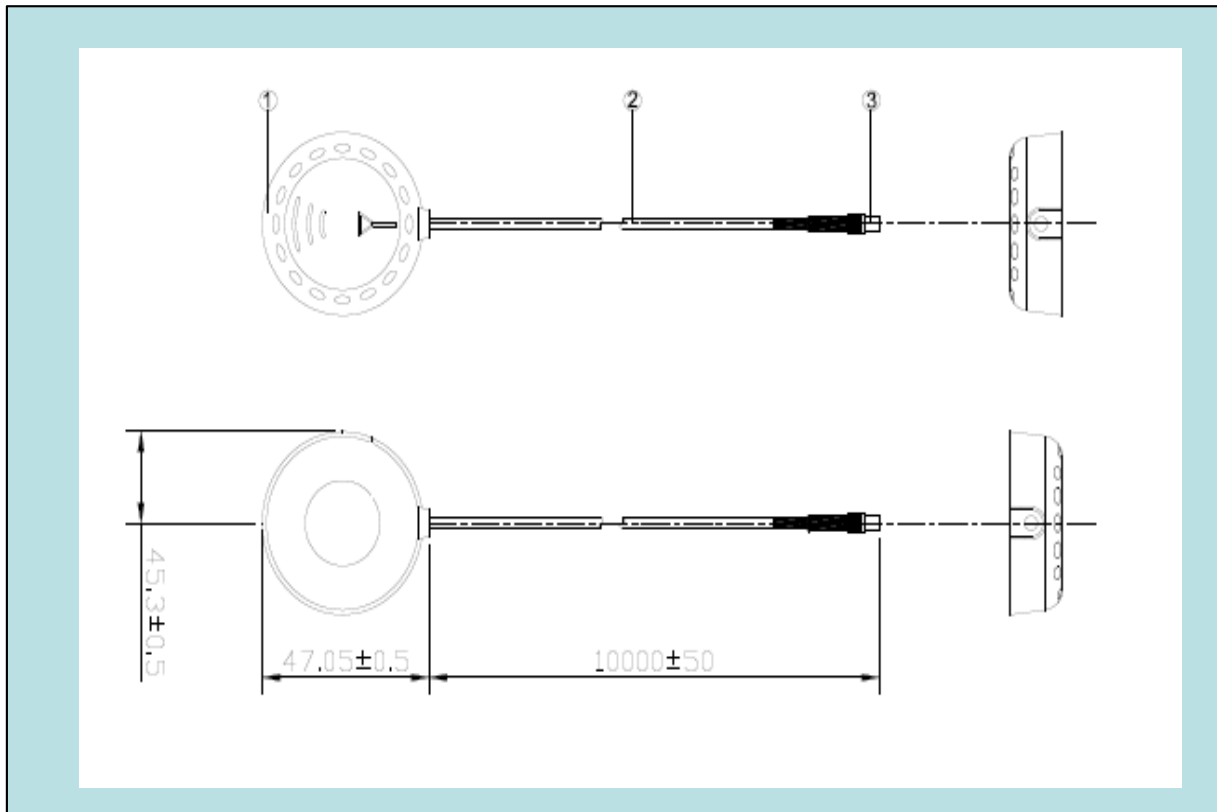

1	Dome	ABS+PC	Black
2	Cable	RG-174	10050mm
3	MCX Pug	Brass	Au Plated
4	Shrink Tub	PVC	Black

**Not to Scale**                      **Unit :** mm                      **PN:** ANTDOM-10-MMCX-WPM  
**Title:** GPS MMCX Water Proof                      ROHS

## X-ON Electronics

Largest Supplier of Electrical and Electronic Components

*Click to view similar products for [Antennas](#) category:*

*Click to view products by [Inventek](#) manufacturer:*

Other Similar products are found below :

[GAN30084EU](#) [930-033-R](#) [GW17.07.0250E](#) [1513563-1](#) [EXE902SM](#) [APAMPG-117](#) [MAF94383](#) [W3908B0100](#) [W6102B0100](#) [YE572113-30RSMM](#) [108-00014-50](#) [66089-2406](#) [SPDA17RP918](#) [A09-F8NF-M](#) [A09-F5NF-M](#) [RGFRA1903041A1T](#) [W3593B0100](#) [W3921B0100](#) [SIMNA-868](#) [SIMNA-915](#) [SIMNA-433](#) [W1044](#) [W1049B090](#) [A75-001](#) [WTL2449CQ1-FRSMM](#) [CPL9C](#) [EXB148BN](#) [0600-00060](#) [TRA9020S3PBN-001](#) [Y4503](#) [GD5W-28P-NF](#) [MA9-7N](#) [GD53-25](#) [GD5W-21P-NF](#) [C37](#) [MAF94051](#) [MA9-5N](#) [EXD420PL](#) [B1322NR](#) [QWFTB120](#) [MAF94271](#) [MAF94300](#) [GPSMB301](#) [FG4403](#) [AO-AGSM-OM54](#) [5200232](#) [MIKROE-2349](#) [WCM.01.0111](#) [MIKROE-2393](#) [MIKROE-2352](#)