



INVENTEK SYSTEMS
ISM4334X-L77
Embedded SiP Module
802.11 a/b/g/n
Bluetooth 4.0 &
NFC Data Sheet



Table of Contents

1	PART NUMBER DETAIL DESCRIPTION	3
1.1	Ordering Information	3
2	OVERVIEW	3
3	FEATURES	4
3.1	Limitations	5
4	COMPLEMENTARY DOCUMENTATION	5
4.1	Inventek Systems	5
5	BLOCK DIAGRAM.....	6
6	HOST INTERFACES	6
6.1	UART Interface	6
6.2	NFC Host Interfaces (ISM43341 only).....	8
7	ELECTRICAL SPECIFICATIONS	8
7.1	Absolute Maximum Ratings	8
7.2	Environmental Ratings.....	9
7.3	Recommended Operating Conditions and DC Characteristics	9
8	RF SPECIFICATIONS	9
8.1	Bluetooth RF Specifications	9
8.2	WLAN RF Specifications	10
8.3	Environmental Specifications	13
9	PIN OUT AND DESCRIPTIONS	14
9.1	Module Pin-Out (1 of 2)	14
9.2	Module Pin-Out (2 of 2)	15
9.3	Recommended PCB Footprint (Bottom View).....	16
9.4	Recommended PCB Footprint (Top View)	17
9.5	Detailed Pin Description	18
10	Product Compliance Considerations.....	20
11	Reflow Profile.....	21
12	Packaging Information.....	22
12.1	MSL Level / Storage Condition	22
12.2	Device baking requirements prior to assembly.....	23
13	REVISION CONTROL	23
14	CONTACT INFORMATION.....	23

1 PART NUMBER DETAIL DESCRIPTION

1.1 Ordering Information

Device	Description	Ordering Number
ISM43341-L77	2.4/5G Wi-Fi, Bluetooth, NFC SiP Module	ISM43341-L77
ISM43340-L77	2.4/5G Wi-Fi, Bluetooth SiP Module	ISM43340-L77
ISM43341-SDIO-EVB or ISM43340	SDIO Evaluation Board	ISM43341-SDIO-EVB

2 OVERVIEW

The Inventek ISM4443X single-chip quad-radio device provides the highest level of integration for a wireless system, with integrated dual band (2.4 GHz/ 5 GHz) IEEE 802.11 a/b/g and single-stream IEEE 802.11n MAC/baseband/radio, Bluetooth 4.0. The ISM43341 also integrates a low power NFC controller. The ISM4443X includes integrated power amplifiers, LNAs and T/R switches for the 2.4 GHz and 5 GHz WLAN bands, greatly reducing the external part count, PCB footprint, and cost of the solution.

It provides a small form-factor solution with minimal external components to drive down cost for mass volumes and allows for handheld device flexibility in size, form and function. Comprehensive power management circuitry and software ensure the system can meet the needs of high mobile devices that require minimal power consumption and reliable operations.

The ISM4443X is compatible with the Bluetooth Low Energy operating mode, which provides a dramatic reduction in the power consumption of the Bluetooth radio and baseband. The primary application for this mode is to provide support for low data rate devices, such as sensors and remote controls.

The ISM4443X implements the highly sophisticated Enhanced Collaborative Coexistence algorithms and hardware mechanisms, allowing for an extremely collaborative Bluetooth coexistence scheme along with coexistence support for external radios such as cellular and LTE, GPS, and Ultra-Wideband. For the WLAN section, host interface is a SDIO v2.0 interface. An independent, high-speed UART is provided for the Bluetooth host interface. Separate independent interfaces (I²C-compatible, SPI and UART) for NFC are also provided.

3 FEATURES

The ISM4443X supports the following WLAN, Bluetooth functions:

- Dual-band 2.4 GHz and 5 GHz IEEE 802.11 a/b/g/n
- Single-stream IEEE 802.11n support for 20 MHz and 40 MHz channels provides PHY layer rates up to 150 Mbps for typical upper-layer throughput in excess of 90 Mbps.
- Supports a single 2.4 GHz antenna shared between WLAN and Bluetooth
- IEEE 802.11a/b/g/n dual-band radio with internal Power Amplifiers, LNAs and T/R switches
- OneDriver™ software architecture for easy migration from existing embedded WLAN and Bluetooth devices as well as future devices.
- Bluetooth v4.0 with integrated Class 1 PA
- Concurrent Bluetooth, NFC and WLAN operation
- On-chip WLAN driver execution capable of supporting IEEE 802.11 functionality
- Single and dual-antenna support
- WLAN host interface :
 - SDIO v2.0, including default and high-speed timing.
- BT host digital interface (can be used concurrently with above interface):
 - UART (up to 4 Mbps)
- ECI – enhanced coexistence support, ability to coordinate BT SCO transmissions around WLAN receives
- I²S/PCM for BT audio
- HCI high-speed UART (H4, H4 +, H5) transport support
- Bluetooth SmartAudio® technology improves voice and music quality to headsets
- Bluetooth low power inquiry and page scan
- Bluetooth Low Energy (BLE) support
- Bluetooth Packet Loss Concealment (PLC)
- Bluetooth Wide Band Speech (WBS)

The BBC supports all Bluetooth 4.0 features, with the following benefits:

- Dual-mode classic Bluetooth and classic Low Energy (BT and BLE) operation.
- Low Energy Physical Layer
- Low Energy Link Layer
- Enhancements to HCI for Low Energy
- Low Energy Direct Test mode
- AES encryption

The ISM43341 supports the following NFC features:

- Support for the ISO/IEC 18092, ISO/IEC 21481, ISO/IEC 14443 Types A, B and B', Japanese Industrial Standard (JIS) (X) 6319-4 and ISO/IEC 15693 standards
- No active components required for antenna or field-power conditioning
- Individual byte framing

- Hardware-based collision detection and modulation controls
- Reader/Writer (R/W) mode
- Active and Passive Peer-to-Peer (P2P) mode
- Tag/Card Emulation mode:
 - Support for battery-enabled card emulation mode
 - Support for two levels of “residual” battery-assisted card emulation mode
 - Support for “battery-off” card emulation mode (completely powered from the field)
- Dual Signal Wire Protocol (SWP) interfaces:
 - SWP_0 with platform power management unit (PMU) power switching to a UICC SIM card
 - SWP_1 for embedded secure element or a second UICC SIM card
- Supports Application ID (AID) routing between a reader and secure element(s)
- Ability to recover card emulation personality data
- Internal low-power oscillator for periodic wake-up and mode switch operation
- Low-Power Target Detection mode for extremely low average current consumption (“sniff mode”)
- NFC Forum NFC Controller Interface (NCFI) for the host interface

3.1 Limitations

Inventek Systems products are not authorized for use in safety-critical applications (such as life support) where a failure of the Inventek Systems product would reasonably be expected to cause severe personal injury or death.

4 COMPLEMENTARY DOCUMENTATION

4.1 Inventek Systems

- Evaluation Board
 - SDIO Evaluation Board Specification
 - EVB User’s Guide
 - Drivers under NDA
 - Design Guidelines

5 BLOCK DIAGRAM

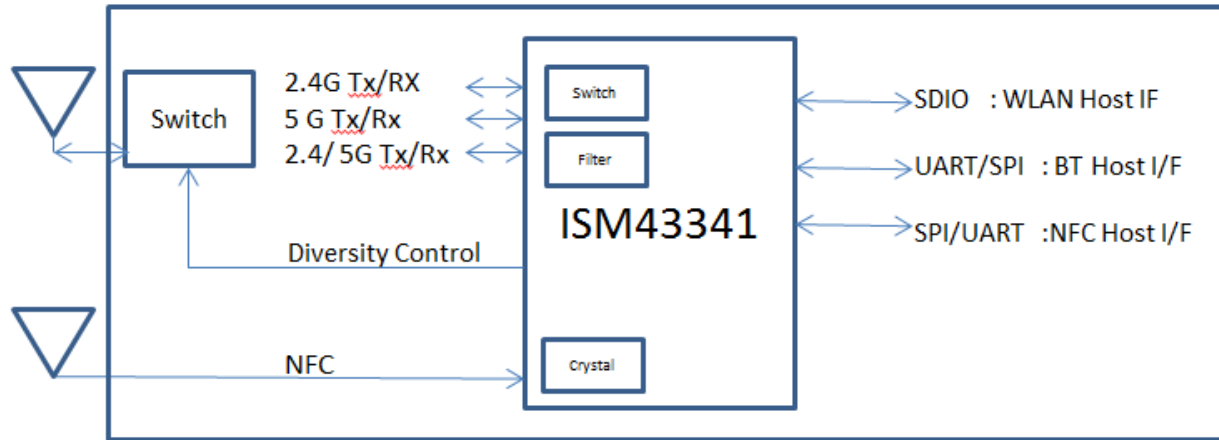

Figure 1 Inventek's ISM4443X General Block Diagram (NFC on ISM43341 version only)

6 HOST INTERFACES

6.1 UART Interface

The ISM4443X shares a single UART for Bluetooth. The UART is a standard 4-wire interface (RX, TX, RTS and CTS) with adjustable baud rates from 9600 bps to 4.0 Mbps. The interface features an automatic baud rate detection capability that returns a baud rate selection. Alternatively, the baud rate may be selected through a vendor-specific UART HCI command.

The UART has a 1040-byte receive FIFO and a 1040-byte transmit FIFO to support EDR. Access to the FIFO is conducted through the AHB interface through either DMA or the CPU. The UART supports the Bluetooth 4.0 UART HCI specification: H4, a custom Extended H4 and H5. The default baud rate is 115.2 Kbaud.

The UART supports the 3-wire H5 UART transport, as described in the Bluetooth specification ("Three-wire UART Transport Layer"). Compared to H4, the H5 UART transport reduces the number of signal lines required by eliminating the CTS and RTS signals.

The ISM4443X UART can perform XON/XOFF flow control and includes hardware support for the Serial Line input Protocol (SLIP). It can also perform wake-on activity. For example, activity on the RX or CTS inputs can wake the chip from a sleep state.

Normally, the UART baud rate is set by a configuration record downloaded after device reset, or by automatic baud rate detection, and the host does not need to adjust the baud rate. Support for changing the baud rate during normal HCI UART operation is included through a vendor-specific command that allows the host to adjust the contents of the baud rate registers. The ISM4443X UARTs operate correctly with the host UART as long as the combined baud rate error of the two devices is within $\pm 2\%$ (see Table 12).

<i>Desired Rate</i>	<i>Actual Rate</i>	<i>Error (%)</i>
4000000	4000000	0.00
3692000	3692308	0.01
3000000	3000000	0.00
2000000	2000000	0.00
1500000	1500000	0.00
1444444	1454544	0.70
921600	923077	0.16
460800	461538	0.16
230400	230796	0.17
115200	115385	0.16
57600	57692	0.16
38400	38400	0.00
28800	28846	0.16
19200	19200	0.00
14400	14423	0.16
9600	9600	0.00

Table 1: Example of Common Baud Rates

6.2 NFC Host Interfaces (ISM43341 only)

The ISM43341 supports UART, I²C-compatible BSC, and SPI for the host interface physical transport layer. The host interface type is selected upon power-up boot, depending upon the state of the NFC_SPI_INT pin.

- NFC_SPI_INT pulled low – The UART interface will be selected
- NFC_SPI_INT pulled high – The I²C-compatible BSC slave interface will be selected
- NFC_SPI_INT floating – The SPI interface will be selected.

After boot, the NFC_SPI_INT signal will function as the SPI interrupt output. During power-up boot, the external host must leave this pin floating, as in the case of the tri-state or input pin. The external host must also ignore interrupts from this signal for a period of 10 milliseconds after boot-up.

The NFC host interface pins are multiplexed onto shared signals as defined in Table 2.

UART	BSC	SPI
NFC_CTS	I2C_REQ	SPI_CS
NFC_RTS	I2C_SCL	SPI_MISO
NFC_URX	-	SPI_CLK
NFC_UTX	I2C_SDA	SPI-MOSI
Pull low	Pull high	NFC_SPI_INT

Table 2: NFC Host Interface Multiplexing

7 ELECTRICAL SPECIFICATIONS

7.1 Absolute Maximum Ratings

 **Caution!** The absolute maximum ratings in Table 28 indicate levels where permanent damage to the device can occur, even if these limits are exceeded for only a brief duration. Functional operation is not guaranteed under these conditions. Operation at absolute maximum conditions for extended periods can adversely affect long-term reliability of the device.

Rating	Symbol	Value	Unit
DC supply for VBAT and PA driver supply	VBAT	-0.5 to +6.0	V
DC supply voltage for digital I/O	VIO	-0.5 to 3.9	V

Table 3: Absolute Maximum Ratings

7.2 Environmental Ratings

Characteristic	Value	Units	Conditions/Comments
Ambient Temperature (Ta)	-30 to +85	°C	* Functional operation
Storage Temperature	-40 to +125	°C	-
Relative Humidity	Less than 60	%	<u>Storage</u>
	Less than 85	%	<u>Operation</u>

Table 4: Environmental Ratings

7.3 Recommended Operating Conditions and DC Characteristics

 **Caution!** Functional operation is not guaranteed outside of the limits shown in Table 31 and operation outside these limits for extended periods can adversely affect long-term reliability of this devices.

Parameter	Symbol	Min	Typical	Max	Unit
DC supply Voltage for VBAT	VBAT	3.0	3.3	4.8	V
DC supply voltage for digital I/O	VIO	1.8	3.3	3.6	V

Table 5: Recommended Operating Conditions and DC Characteristics

- a. The ISM43341 is functional across this range of voltages. Optimal RF performance specified in the data sheet, however, is guaranteed only for $3.0V > VBAT > 4.8V$.
- b. The maximum continuous voltage is 4.8V. Voltages up to 5.5V for up to 10 seconds, cumulative duration, over the lifetime of the device are allowed. Voltages as high as 5.0V for up to 250 seconds, cumulative duration, over the lifetime of the device are allowed.
- c. Programmable 2 mA to 16 mA drive strength. Default is 10 mA

8 RF SPECIFICATIONS

8.1 Bluetooth RF Specifications

Note: Values in this datasheet are design goals and are subject to change based on the result of device characterization.

Unless otherwise stated, limit values apply for the conditions specified in Tabel 29: “Environmental Ratings” on page 117 and table 31: “Recommended Operating Conditions and DC Characteristics” on page 118. Typical values apply for the following conditions:

- VBAT = 3.6V
- Ambient temperature +25°C

Parameter	Conditions	Min	Typical	Max	Unit
Note: The specifications in this table are measured at the Chip port output unless otherwise specified:					
General					
Frequency Range	-	2402	-	2480	MHz
RX sensitivity	GFSK, 0.1% BER, 1 Mbps	-	-93.5	-	dBm
	$\pi/4$ -DQPSK, 0.01% BER, 2 Mbps	-	-95.5	-	dBm
	8-DPSK, 0.01% BER, 3 Mbps	-	-89.5	-	dBm
Input IP3	-	-16	-	-	dBm
Maximum input at antenna	-	-	-	-20	dBm

Table 6: Bluetooth Receiver RF Specifications

Parameter	Conditions	Min	Typical	Max	Unit
General					
Frequency Range	-	2402	-	2480	MHz
Basic rate (GFSK) Tx power at Bluetooth	-	10.0	12.0	-	dBm
QPSK Tx Power at Bluetooth	-	7.0	9.0	-	dBm
8PSK Tx Power at Bluetooth	-	7.0	9.0	-	dBm
Power control step	-	2	4	6	dB

Table 7: Bluetooth Transmitter RF Specifications

8.2 WLAN RF Specifications

The ISM4443X includes an integrated dual-band direct conversion radio that supports either the 2.4 GHz band or the 5 GHz band. The ISM4443X does not provide simultaneous 2.4 GHz and 5 GHz operation. This section describes the RF characteristics of the 2.4 GHz and 5 GHz portions of the radio.

Note: Values in the data sheet are design goals and are subject to change based on the results of device characterization.

Unless otherwise stated, limit values apply for the condition specified in Table 29: “Environmental Ratings” on page 117 and Table 31: “Recommended Operating Conditions and DC Characteristics” on page 118. Typical values apply for the following conditions:

- VBAT = 3.6V
- Ambient temperature +25°C

2.4 GHz Band General RF Specifications

Item	Conditions	Min	Typical	Max	Unit
Tx/Rx switch time	Including TX ramp down	-	-	5	μs
Rx/Tx switch time	Including TX ramp up	-	-	2	μs
Power-up and power-down ramp time	DSSS/CCK Modulations	-	-	<2	μs

Table 8: 2.4 GHz Band General RF Specifications

WLAN 2.4 GHz Receiver Performance Specification

Parameter	Condition/Notes	Min	Typical	Max	Unit
Frequency Range	-	2400	-	2500	MHz
RX sensitivity (8% PER for 1024 octet PSDU) ^a	1 Mbps DSSS	-	-97.9	-	dBm
	2 Mbps DSSS	-	-96.9	-	dBm
	5.5 Mbps DSSS	-	-92.5	-	dBm
	11 Mbps DSSS	-	-90.7	-	dBm
RX sensitivity (10% PER for 1024 octet PSDU) ^a	6 Mbps OFDM	-	-92.7	-	dBm
	9 Mbps OFDM	-	-91.4	-	dBm
	12 Mbps OFDM	-	-89	-	dBm
	18 Mbps OFDM	-	-87.4	-	dBm
	24 Mbps OFDM	-	-84.4	-	dBm
	36 Mbps OFDM	-	-81.7	-	dBm
	48 Mbps OFDM	-	-78.3	-	dBm
	54 Mbps OFDM	-	-77.1	-	dBm
RX sensitivity (10% PER for 4096	20 MHz channel spacing for all MCS rates (GF)				

octet PSDU) ^{a,b} Defined for default parameters: GF, 800 ns GI, and non-STBC.	MCS0	-	-92.6	-	dBm
	MCS 1	-	-89.6	-	dBm
	MCS 2	-	-87.3	-	dBm
	MCS 3	-	-84.7	-	dBm
	MCS 4	-	-82	-	dBm
	MCS 5	-	-78.4	-	dBm
	MCS 6	-	-76.9	-	dBm
	MCS 7	-	-75	-	dBm
RX sensitivity (10% PER for 4096 octet PSDU) ^{a,b} Defined for default parameters: GF, 800 ns GI, and non-STBC.	40 MHz channel spacing for all MCS rates (GF)				
	MCS0	-	-91	-	dBm
	MCS 1	-	-87.5	-	dBm
	MCS 2	-	-85.5	-	dBm
	MCS 3	-	-83	-	dBm
	MCS 4	-	-80	-	dBm
	MCS 5	-	-75	-	dBm
	MCS 6	-	-73.5	-	dBm
MCS 7	-	-72	-	dBm	
RX sensitivity (10% PER for 4096 octet PSDU) ^{a,c} Defined for default parameters: Mixed mode-800n ns GI, and non-STBC.	20 MHz channel spacing for all MCS rates (Mixed mode)				
	MCS0	-	-91	-	dBm
	MCS 1	-	-87.9	-	dBm
	MCS 2	-	-85.5	-	dBm
	MCS 3	-	-82.8	-	dBm
	MCS 4	-	-79.9	-	dBm
	MCS 5	-	-76.2	-	dBm
	MCS 6	-	-74.6	-	dBm
MCS 7	-	-72.6	-	dBm	
RX sensitivity (10% PER for 4096 octet PSDU) ^{a,b} Defined for default parameters: GF, 800 ns GI, and non-STBC.	40 MHz channel spacing for all MCS rates (Mixed mode)				
	MCS0	-	-89.0	-	dBm
	MCS 1	-	-85.4	-	dBm
	MCS 2	-	-83.2	-	dBm
	MCS 3	-	-80.6	-	dBm
	MCS 4	-	-77.4	-	dBm
	MCS 5	-	-72.3	-	dBm
	MCS 6	-	-70.6	-	dBm
MCS 7	-	-69.0	-	dBm	

Table 9: WLAN 2.4 GHz Receiver Performance Specifications

WLAN 5 GHz Receiver Performance Specifications

Note: The specifications in Table 40 are measured at the chip port input, unless otherwise specified

Parameter	Condition/Notes	Min	Typical	Max	Unit
Frequency Range	-	4900	-	5845	MHz
RX sensitivity (10% PER for 1000 octet PSDU) ^a	6 Mbps OFDM	-	-91.2	-	dBm
	9 Mbps OFDM	-	-89.9	-	dBm

	12 Mbps OFDM	-	-87.5	-	dBm
	18 Mbps OFDM	-	-85.9	-	dBm
	24 Mbps OFDM	-	-82.9	-	dBm
	36 Mbps OFDM	-	-80.2	-	dBm
	48 Mbps OFDM	-	-76.8	-	dBm
	54 Mbps OFDM	-	-75.6	-	dBm
RX sensitivity (10% PER for 4096 octet PSDU) ^a Defined for default parameters: GF, 800 ns GI, and non-STBC.	20 MHz channel spacing for all MCS rates (GF)				
	MCS0	-	-91.1	-	dBm
	MCS 1	-	-88.1	-	dBm
	MCS 2	-	-85.8	-	dBm
	MCS 3	-	-83.2	-	dBm
	MCS 4	-	-80.5	-	dBm
	MCS 5	-	76.9	-	dBm
	MCS 6	-	75.4	-	dBm
MCS 7	-	-73.5	-	dBm	
RX sensitivity (10% PER for 4096 octet PSDU) ^a Defined for default parameters: GF, 800 ns GI, and non-STBC.	40 MHz channel spacing for all MCS rates (GF)				
	MCS0	-	-89.5	-	dBm
	MCS 1	-	-86	-	dBm
	MCS 2	-	-84	-	dBm
	MCS 3	-	-81.5	-	dBm
	MCS 4	-	-78.5	-	dBm
	MCS 5	-	-73.5	-	dBm
	MCS 6	-	-72	-	dBm
MCS 7	-	-70.5	-	dBm	

Table 10: WLAN 5 GHz Receiver Performance Specifications

8.3 Environmental Specifications

Item	Description
Operating temperature range	-40 deg. C to +85 deg. C
Storage temperature range	-40 deg. C to +85 deg. C
Humidity	95% max non-condensing

Note 1: The ISM4443X supports a functional operating range of -40°C to +85°C. However the optimal RF performance specified in this data sheet is only guaranteed for temperatures from -10°C to +65°C

9 PIN OUT AND DESCRIPTIONS

9.1 Module Pin-Out (1 of 2)

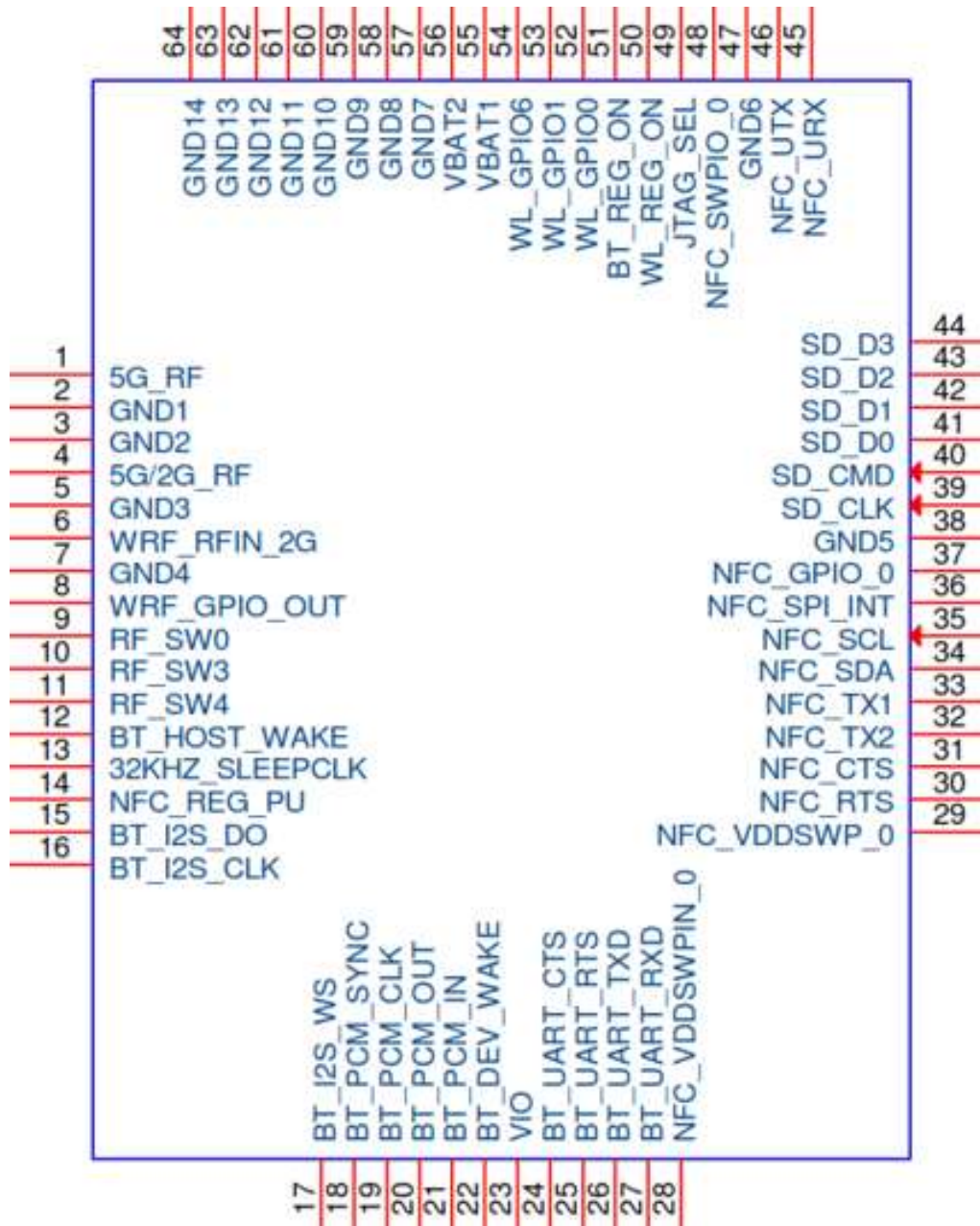

9.2 Module Pin-Out (2 of 2)

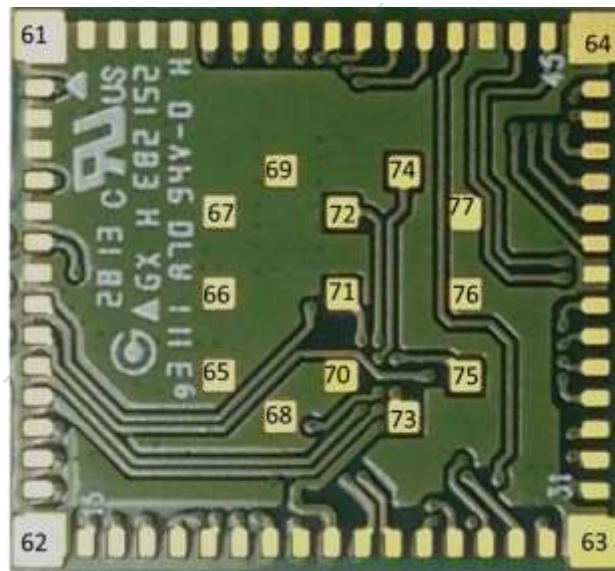
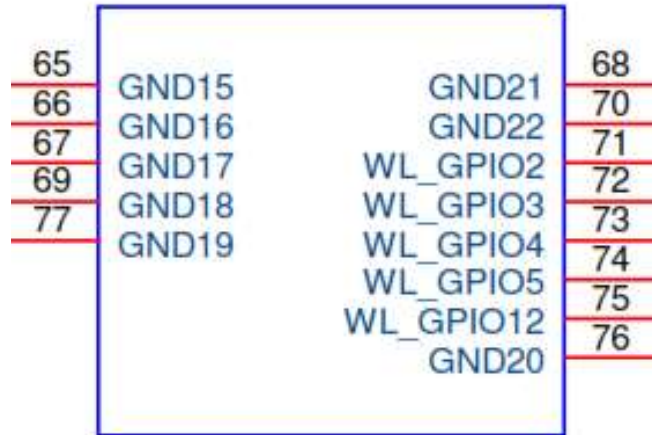

9.3 Recommended PCB Footprint (Bottom View)

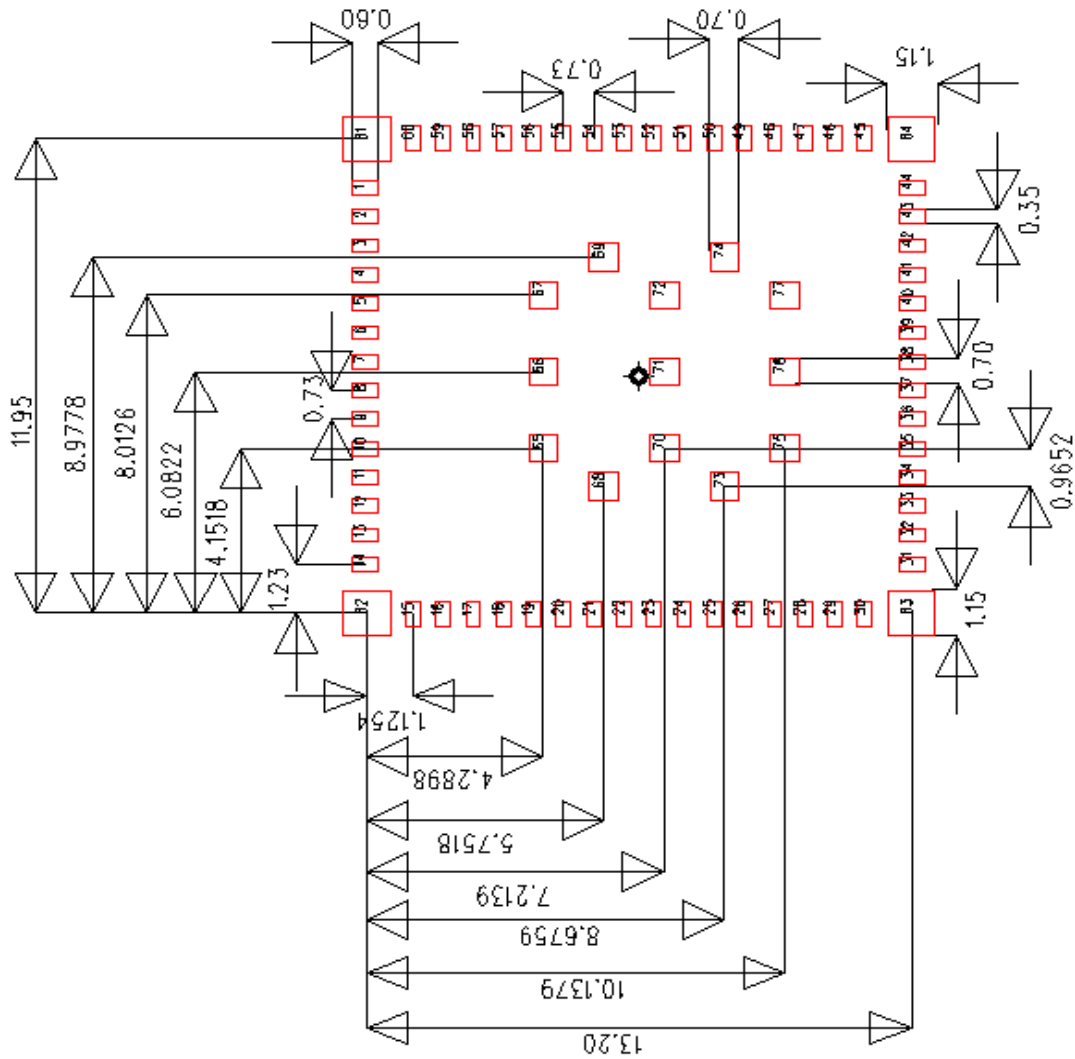

9.5 Detailed Pin Description

Pin No.	Name	TYPE	Description
1	RFIN_5G	RF in	RF IN 5G
2	Ground	G	GRD
3	Ground	G	GRD
4	5 GHZ & 2.4 G RF in	RF in	
5	Ground	G	GRD
6	2.4 G RF in	RF in	RF IN 2G
7	Ground	G	
8	WRF_GPIO_OUT	G	GPIO_OUT
9	RF_SWO	O	Ext. RF Switch Enable -NC
10	RF_SW3	O	Ext. RF Switch Enable -NC
11	RF_SW4	O	Ext. RF Switch Enable -NC
12	BT_HOST_WAKE	O	BT_Host_Wake to Host Active High
13	32 Khz sleep clk		
14	NFC_REG_PU	I	NFC Regulator Power Up Active High
15	BT_12S_DO		BT_I2S DO
16	BT_12S_CLK		BT_I2S_CLK
17	BT_12S_WS		BT_I2S_WS
18	BT_PCM_SYNC		BT PCM Sync
19	BT_PCM_CLK		BT PCM Clock
20	BT_PCM_OUT		BT_PCM_Out
21	BT_PCM_IN		BT_PCM In
22	BT_DEV_WAKE	I	BT Dev Wake up from Host Active High
23	Vio	V	I/O Supply Voltage (1.8-3.3V)
24	BT_UART_CTS_L	I	BT_UART_CTS_N
25	BT_UART_RTS_L	O	BT_UART_RTS_N
26	BT_UART_TXD	I/O	BT_UART_TXD
27	BT_UART_RXD	I/O	BT_UART_RXD
28	*NFC_VDDSWPIN_0	I	NFC single wire protocol and power - UICC
29	*NFC_VDDSWP_0	O	NFC single wire protocol and power
30	*NFC_RTS	O	NFC UART Request to Send
31	*NFC_CTS	I	NFC UART Clear-to-Send
32	*NFC_TX2	RF	NFC antenna TX/RX Pin 2
33	*NFC_TX1	RF	NFC antenna TX/RX Pin 1
34	*NFC_SDA	I/O	BSC data for EEPROM
35	*NFC_SCL	O	BSC clock for EEPROM
36	*NFC_SPI_INT	I/O	NFC Host Interface/Select SPI interrupt

37	*NFC_GPIO1	I/O	NFC GPIO
38	GND	G	Gnd
39	SDIO_CLK	I	SDIO clk
40	SDIO_CMD	I/O	SDIO command Lin or data input
41	SDIO_DATA_0	I/O	SDIO data
42	SDIO_DATA_1	I/O	SDIO 1
43	SDIO_DATA_2	I/O	SDIO 2
44	SDIO_DATA_3	I/O	SDIO 3
45	*NFC_URX	I	NFC UART RX
46	*NFC_UTX	O	NFC UART TX
47	GND	G	Ground
48	*NFC_SWPIO_0	I/O	NFC single wire protocol and power
49	JTAG_SEL		JTAG Select (High to select JTAG)
50	WL_REG_ON	I	Wireless LAN Power up (Active high)
51	BT_REG_ON	I	Power up Bluetooth (Active High)
52	GPIO_0	O	GPIO
53	GPIO_1	I/O	GPIO
54	GPIO_6	I/O	GPIO
55		VBAT	3.3v
56		VBAT	3.3v
57		G	Ground
58		G	Ground
59		G	Ground
60		G	Ground
61		G	Ground
62		G	Ground
63		G	Ground
64		G	Ground
65		G	Ground
66		G	Ground
67		G	Ground
68		G	Ground
69		G	Ground

70		G	Ground
71	WL_GPIO2		WL_GPIO2
72	WL_GPIO3		WL_GPIO3
73	WL_GPIO4		WL_GPIO4
74	WL_GPIO5		WL_GPIO5
75	WL_GPIO_12		WL_GPIO_12
76		G	Ground
77		G	Ground

Note: All NFC pins labelled with (*) are only available for ISM43341, and for ISM43340 these pins should be left floating.

10 Product Compliance Considerations

RoHS: Restriction of Hazardous Substances (RoHS) directive has come into force since 1st July 2006 all electronic products sold in the EU must be free of hazardous materials, such as lead. Inventek is fully committed to being one of the first to introduce lead-free products while maintaining backwards compatibility and focusing on a continuously high level of product and manufacturing quality.

EMI/EMC: The Inventek module design embeds EMI/EMC suppression features and accommodations to allow for higher operational reliability in noisier (RF) environments and easier integration compliance in host (OEM) applications.

FCC/CE: The module will be in compliance test for FCC/CE

11 Reflow Profile

- Reference the IPC/JEDEC standard.
- Peak Temperature: $<250^{\circ}\text{C}$
- Number of Times: ≤ 2 times

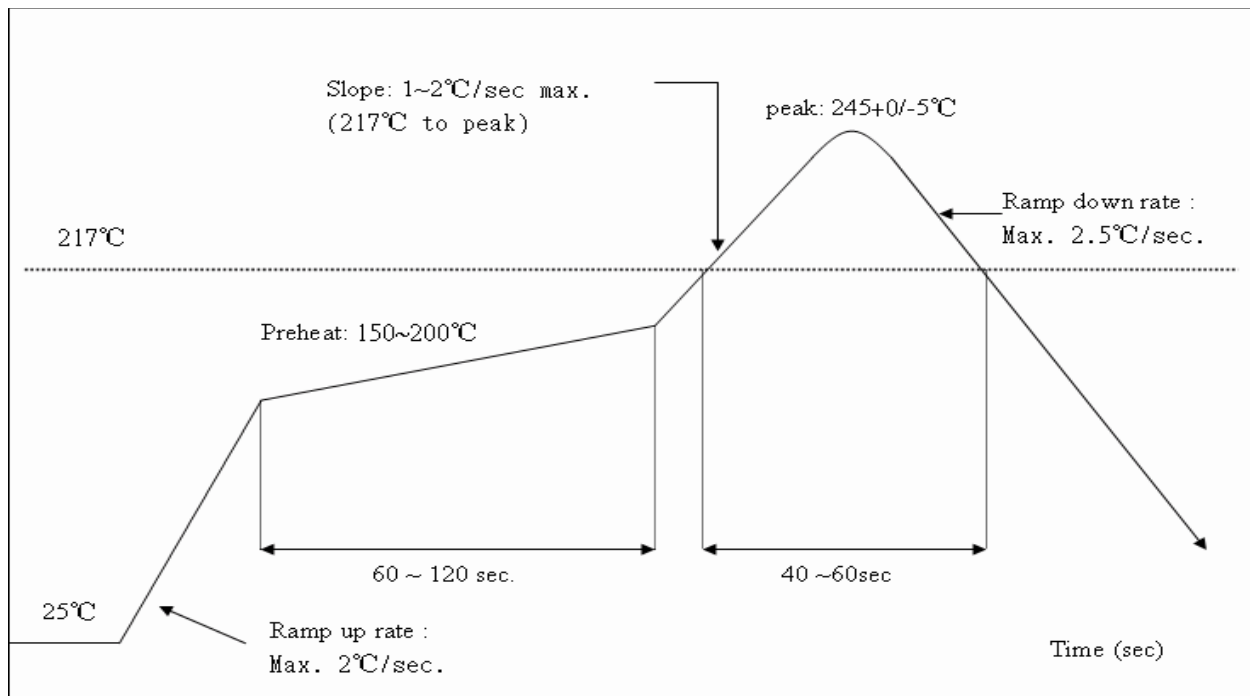

12 Packaging Information

12.1 MSL Level / Storage Condition

	<h3>Caution</h3> <p>This bag contains</p> <h3>MOISTURE-SENSITIVE DEVICES</h3> <p>Do not open except under controlled conditions</p>	<p>LEVEL</p> <div style="border: 1px solid black; padding: 5px; width: 40px; margin: 0 auto;">4</div>
	<p>1. Calculated shelf life in sealed bag: 12 months at <math>< 40^{\circ}\text{C}</math> and <math>< 90\%</math> relative humidity (RH)</p> <p>2. Peak package body temperature: 225°C 240°C 250°C 260°C</p> <p style="margin-left: 100px;"> <input type="checkbox"/> <input type="checkbox"/> <input checked="" type="checkbox"/> <input type="checkbox"/> </p> <p>3. After bag is opened, devices that will be subjected to reflow solder or other high temperature process must</p> <p style="margin-left: 20px;">a) Mounted within: 48 hours of factory conditions <math>< 30^{\circ}\text{C}/60\%</math> RH, OR</p> <p style="margin-left: 20px;">b) Stored at <math>< 10\%</math> RH</p> <p>4. Devices require bake, before mounting, if:</p> <p style="margin-left: 20px;">a) Humidity Indicator Card is >10% when read at $23 \pm 5^{\circ}\text{C}$</p> <p style="margin-left: 20px;">b) 3a or 3b not met</p> <p>5. If baking is required, devices may be baked for 24 hours at $125 \pm 5^{\circ}\text{C}$</p> <p>Note : If device containers cannot be subjected to high temperature or shorter bake times are desired, reference IPC/JEDEC J-STD-033 for bake procedure</p> <p>Bag Seal Date: <u> See-SEAL DATE LABEL </u></p> <p>Note: Level and body temperature defined by IPC/JEDEC J-STD-020</p>	

12.2 Device baking requirements prior to assembly

Boards must be baked prior to rework or assembly to avoid damaging moisture sensitive components during localized reflow. The default bake cycles is 24 hours at 125C.

Maintaining proper control of moisture uptake in components is critical.

Before opening the shipping bag and attempting solder reflow, you should maintain a minimal out-of-bag time and ensure the highest possible package reliability for the final product.

13 REVISION CONTROL

Document : ISM4443X	Wi-Fi SIP module
External Release	DOC-DS-20023

Date	Author	Revision	Comment
1/15/2015	KMT	1.0	Preliminary
12/17/2015	KMT	1.1	Released
1/12/2016	KMT	1.2	Pin list Update
3/22/2016	KMT	3.2	Pin Description, added Power Consumption and P/N

14 CONTACT INFORMATION

Inventek Systems
 2 Republic Road
 Billerica Ma, 01862
 Tel: 978-667-1962
Sales@inventeksys.com

www.inventeksys.com

Inventek Systems reserves the right to make changes without further notice to any products or data herein to improve reliability, function, or design. The information contained within is believed to be accurate and reliable. However Inventek Systems does not assume any liability arising out of the application or use of this information, nor the application or use of any product or circuit described herein, neither does it convey any license under its patent rights nor the rights of others.

X-ON Electronics

Largest Supplier of Electrical and Electronic Components

Click to view similar products for [Multiprotocol Modules](#) category:

Click to view products by [Inventek](#) manufacturer:

Other Similar products are found below :

[ESP32-C3-MINI-1-N4](#) [ESP32-C3-MINI-1U-N4](#) [ESP32-C3-WROOM-02-N4](#) [NINA-W102-00B](#) [AIW-355 DQ-N01](#) [AIW-355 DQ-C01](#)
[EWM-W188M201E](#) [EWM-W192K1](#) [PCM-24S2WF-BE](#) [ATWINC3400-MR210CA122](#) [ESP32-WROVER-B](#) [ESP32-WROVER-IB](#) [INP1010-](#)
[A1-ITP](#) [INP1011-A2-ITP](#) [M1003GXT00](#) [ATWINC3400-MR210CA122-T](#) [ATWINC3400-MR210CA131](#) [TWR0083](#) [RS9113-NB0-D0N](#)
[WYSBHVXG](#) [WYSBMVXG](#) [ESP32-WROOM-32](#) [cs-superb-03](#) [cs-superb-04](#) [TEL0135](#) [ReliaCELL10-20-26](#) [POL-2G-KIT](#) [POL-3G-](#)
[KIT](#) [ENWF9201AZEF](#) [STM32WB5MMGH6TR](#)